

# We are IntechOpen, the world's leading publisher of Open Access books Built by scientists, for scientists

**4,800**

Open access books available

**122,000**

International authors and editors

**135M**

Downloads

Our authors are among the

**154**

Countries delivered to

**TOP 1%**

most cited scientists

**12.2%**

Contributors from top 500 universities



**WEB OF SCIENCE™**

Selection of our books indexed in the Book Citation Index  
in Web of Science™ Core Collection (BKCI)

Interested in publishing with us?  
Contact [book.department@intechopen.com](mailto:book.department@intechopen.com)

Numbers displayed above are based on latest data collected.

For more information visit [www.intechopen.com](http://www.intechopen.com)



# Development of Miniature $^{125}\text{I}$ - Seeds for the Treatment of Prostate Cancer

Sanjay Kumar Saxena and Ashutosh Dash

*Radiopharmaceuticals Division, Bhabha Atomic Research Centre, Trombay, Mumbai  
India*

## 1. Introduction

Cancer of prostate is one of the very common diseases of ageing men with incidence rises up 40% over the age of 75-80 years. It has also been noticed recently, that incidences of prostate cancers are on increase specially in many developing countries mainly because of long survival time due to better health care facilities available now-a-days and also due to changes in lifestyles of population of these countries. As compared with white men, black men have a 40% higher risk of the disease and twice the rate of death. The mortality due to prostate cancer has steadily declined for a decade, and it decreased by 4% per year between 1999 and 2003. This decrease may be attributable to several factors, including earlier detection of cancer and improved local and possibly systemic treatment [1]. Thanks to the recent advancements in diagnostic tools, more and more patients are being diagnosed with potentially curable localized prostate cancer at a time where radical local treatment is deemed to be appropriate. For disease that is likely confined to the prostate and the immediate surrounding area, surgery, external beam radiation (EBRT) and seed implantation are the primary treatment options. In recent years, seed implantation has become more popular as a treatment option as it is simpler, less traumatic and the duration of relief is comparable. It has been estimated that up to 50% of patients with early stage prostate cancer are now receiving ultra sound guided seed implantation [2].

## 2. Historical background

Seed implantation for prostate cancer began in 1911. Louis Pasteur suggested that surgical insertion of radium seed into the prostate may eradicate this malignancy [3]. A number of techniques were subsequently used with limited success. In the 1960s, Drs. Scardino and Carlton at Baylor College of Medicine, Houston, reintroduced permanent prostate brachytherapy using  $^{198}\text{Au}$  interstitial implantation in combination with external beam radiation therapy (EBRT)[4].

At about the same time, Dr. Whitmore and colleagues at Memorial Sloan Kettering Cancer Center (MSKCC) also began to insert  $^{125}\text{I}$  seeds through an open incision as a sole treatment [5]. Unfortunately, these early techniques did not allow for clear visualization of the seeds as they were being inserted into the prostate and, as a result, there was often poor dose coverage of the prostate gland. However, some important information was obtained from these early seed implantation approaches. Local control was better in patients who received

high-quality implants and who had low-grade and early-stage cancer. The subsequent development of the transperineal, ultrasound guided approach provided a means to more accurately place seeds and thereby improve dose coverage. In the 1980s, several investigators were exploring new brachytherapy approaches to the treatment of prostate cancer. Drs. Syed and Puthawala pioneered a temporary seed technique of placing the needles while visualizing them through an open laparotomy [6]. In 1983, Dr. Holm introduced the use of transrectal ultrasound to visualize the permanent placement of  $^{125}\text{I}$  seeds via needles inserted through the perineum directly into the prostate [7]. Drs Blasko and Ragde [8] began the first transperineal ultrasound-guided approach in the United States. The transperineal ultrasound-guided, approach resulted in increased accuracy of seed placement and relatively even distribution of seeds throughout the prostate. This marked a major advance in prostate brachytherapy in that it allowed more precise planning of the implant prior to the procedure. These advances also significantly increased the accuracy of seed placement and insured that the prostate would receive the proper number, strength, and positioning of radioactive sources.

The first transrectal ultrasound-guided, template-guided  $^{125}\text{I}$  implant procedure was carried out at the Seattle Prostate Institute in late 1985 and is now being practiced around the world. The original Seattle approach has been modified and improved several times since the original implants. As this procedure has become more popular, many technical improvements have been added to improve the consistency and quality of the procedure. The availability of better imaging techniques such as transrectal ultrasound, fluoroscopy, high quality CT scan, etc. have now made permanent prostate implants much more refined. Today, the implant is planned prior to the procedure either on the day of or several weeks prior to the implant. Typically, the implant is completed in a 45-90 minute outpatient procedure under spinal anesthesia or light general anesthesia [8].

In addition to the availability of loose sealed radioactive sources, seeds incorporating radionuclides such as  $^{125}\text{I}$ ,  $^{103}\text{Pd}$  and  $^{131}\text{Cs}$  are now available in continuous strand form, increasing the likelihood that the seeds will remain in place after implantation. About 60-140 radioactive seeds encompassing the entire prostate gland are used to eradicate the tumor. While slight differences in technique are expected to grow as more and more physicians perform this procedure and as more technical advances are made, the basic approach is quite similar and it remains to be determined whether any single technique will prove superior in controlling the cancer.

### 3. Selection of radionuclide

Beginning in 1967,  $^{125}\text{I}$  became the first radioisotope sealed within a titanium capsule popularly known as seed. While its use continues to this day, many patients and doctors in recent years have chosen shorter half-life isotopes other than  $^{125}\text{I}$  such as  $^{103}\text{Pd}$  and  $^{131}\text{Cs}$ .

Radionuclides used in the prostate radiotherapy are  $^{125}\text{I}$ ,  $^{103}\text{Pd}$  or  $^{131}\text{Cs}$ . The radiation characteristics of these three isotopes are given in Table 1. The high energy (10-50 MeV) cyclotron produced  $^{103}\text{Pd}$  is not yet available in India. The reactor production of  $^{131}\text{Cs}$  is difficult due to low percentage abundance of  $^{130}\text{Ba}$  (~1%) in natural targets and the logistics and cost considerations of this isotope do not permit its use at present. On the other hand,  $^{125}\text{I}$  with its relatively longer half-life and suitable gamma energy coupled with ease of production is a cost effective isotope and can be easily produced by  $(n,\gamma)$  reaction of natural  $^{124}\text{Xe}$  gas in a special set up provided in the research reactors (DHRUVA) of BARC, Mumbai, India. The

production and processing procedures for  $^{125}\text{I}$  have been developed and regular production of this isotope has been commenced by Radiopharmaceuticals Division, BARC, Mumbai.

The Indian pursuit of developing technology for  $^{125}\text{I}$  brachytherapy sources was driven mainly by three considerations, namely, (a) well-established and ease of reliable production of  $^{125}\text{I}$  in several GBq quantities in the research reactors in BARC, (b) need to provide  $^{125}\text{I}$ -brachytherapy sources at an affordable cost to meet the domestic needs, (c) help to ease reliance on import and to promote the beneficial use of  $^{125}\text{I}$ - brachytherapy sources in the country.

Isotope	$T_{1/2}$	Specific Activity (TBq/g)	Mode of Decay	Average Energy (keV)	Dose Delivery	Total Dose	Production methods
$^{125}\text{I}$	60d	650	EC (100%)	28.5	90% in 204 days	145 Gy	$^{124}\text{Xe}(n,\gamma)^{125}\text{Xe}\rightarrow^{125}\text{I}$ Nuclear Reactor
$^{103}\text{Pd}$	17d	2763	EC (100%)	21	90% in 58 days	125 Gy	$^{103}\text{Rh}(p,n)^{103}\text{Pd}$ Cyclotron
$^{131}\text{Cs}$	9 d	3808	EC (100%)	30.4	90% in 33 days	115 Gy	$^{130}\text{Ba}(n,\gamma)^{131}\text{Ba}\rightarrow^{131}\text{Cs}$ Nuclear Reactor

Table 1. Radiation Characteristics of radionuclides used in prostate seed implantation

#### 4. Source requirements

The encapsulated source's outer dimensions are  $\sim 4.75$  mm length and 0.8mm dia. The active core is situated within the shell of the capsules, often of 50 micron thickness. Iodine belongs to the halogen group of elements which is highly reactive. Although several stable compounds of iodides are reported in the literature, most of them have a definite solubility in water/saline. The main challenge, therefore, is to develop a non-leachable source core containing  $^{125}\text{I}$  incorporated in a solid substrate at very high specific activity. Production of the source core in a highly reproducible manner within acceptable dimensional tolerances is yet another challenge. An innovative strategy has to be devised to develop the necessary technology for fabrication of  $^{125}\text{I}$  source core, capsules and encapsulation technique. Preparation of  $^{125}\text{I}$ -brachytherapy sources addresses the following main issues:

- Immobilization of  $^{125}\text{I}$  in a suitable solid matrix.
- Quality evaluation of the sources.
- Fabrication of titanium capsules of suitable dimensions.
- Hermetic Sealing of the capsules by Laser welding.
- Quality assurance of the encapsulated sources.

#### 5. Preparation of $^{125}\text{I}$ miniature source cores

Two types of source core are used for the preparation of  $^{125}\text{I}$  seed; namely

- Rod/wire type sources
- Spherical type sources

Silver is chosen as the basic matrix for immobilization of iodine which functions both as the active support and as the x-ray marker. Iodine-125 can be used directly in its elemental form, or as iodide, iodate, hypiodate, or other ionic forms, or in the form of compounds such as aliphatic or aromatic iodo labeled compounds. The choice of anion(s) depend on

the methodology intended to use. Owing to volatile nature of elemental iodine, iodide ions are used for source preparation. Iodine-125 as iodide may be physically trapped in or on the substrate, by adsorption, or may be chemically attached to it in some way. The radioactive source core should be of an overall size and dimensions to fit inside a conventional seed container suitable for encapsulation. The range of desired activity is about 0.3 to 4.0 mCi per seed.

### 5.1 Preparation of rod/wire type source cores

Silver wires of guaranteed purity of 3 mm length & 0.5mm dia are used to incorporate Iodine-125. The following methodologies were explored for preparing  $^{125}\text{I}$ -silver rod source core.

1. Electrodeposition
2. Physical & physico-chemical adsorption

#### 5.1.1 Electro deposition

Anodic electro deposition of radio iodine ( $^{125}\text{I}$ ) was carried out in a quartz bath size [1.2 cm (dia.), 2.5 cm (ht)] with platinum cathode (1mm). The wires were arranged in the cell as shown in Fig.1. Various experimental parameters such as the current used, radioiodine concentration in the cell and time for deposition were optimized to obtain maximum activity on the silver wire. By this method, more than 85% of the initial radioactivity could be firmly deposited on the source at 20  $\mu\text{A}$  current for 25-30 min duration on the silver wires. These sources with extremely good reproducibility and consistency with respect to activity content, could be by this method [9].

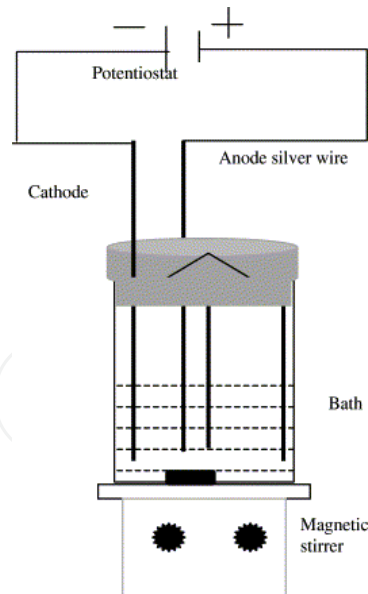

Fig. 1. Schematic diagram of the electro-deposition set-up.

Cieszykowska et al.[10] have also developed an electrochemical method of depositing  $^{125}\text{I}$  from an electrolyte containing 0.01 M NaOH. In brief, 10 ml of solution containing appropriate amount of I-125 was taken in a platinum crucible which served as cathode. The cathode consists of a single silver bar of 3 mm long and 0.5 mm in diameter. The volume of the electrolyte used was 10 mL and the distance between the electrodes was about 20 mm.



The potential of the cell was kept at 233 mV. The electrodeposition was carried out under ultra violet radiation.

### 5.1.2 Iodination of the silver rod

Zhang et al. [11] have described a method of depositing  $^{125}\text{I}$  using chlorinated silver rod. In brief, the procedure involved coating a layer of AgCl on the silver rod of 3 mm long and 0.5 mm in diameter. The activated silver rods were put into 4 mol/l nitric acid and heated for 5 minutes. They were then put into a mixed solution of sodium hypochlorite and hydrochloric acid. The chlorinated silver rods were put in  $\text{Na}^{125}\text{I}$  solution at  $\text{pH} > 6.5$  to deposit required amount of  $^{125}\text{I}$ .

### 5.1.3 Absorption of $^{125}\text{I}$ on a ceramic matrix

Han et al. [12] have described a method of depositing  $^{125}\text{I}$  using a ceramic rods. The ceramic rods of 3 mm long and 0.5 mm sizes were immersed in conc. HF solution for 4 hours, scratched with a specially made pin along the length at regular intervals to made miniature horizontal cavities of  $\sim 0.1$  mm depth. they were then immersed aqueous  $\text{AgNO}_3$  solution to absorb the solution. Impregnation of  $^{125}\text{I}$  on to the treated rod was carried out by the controlled addition of  $\text{Na}^{125}\text{I}$  solution at  $\text{pH} > 9$  to deposit required amount of  $^{125}\text{I}$ . Extending this theme, Park et al.[13] have investigated the possibility of adsorption of  $^{125}\text{I}$  on a  $\text{Ag} + \text{Al}_2\text{O}_3$  rod as a carrier body. The adsorption capacity was more than 95% after 4 hours at a volume of 50  $\mu\text{l}$  containing about 5 mCi of  $^{125}\text{I}$ .

### 5.1.4 Physico-chemical adsorption

Our group have used a novel method to adsorb radioiodine( $^{125}\text{I}$ ) on silver wires, by precoating the wires with palladium[14-15]. The experimental conditions such as amount of radioactivity, carrier concentration, reaction time, reaction temperature, reaction volume, pH of the reaction mixture, etc. were systematically optimized to achieve best results. More than 80% of the initial radioactivity could be firmly deposited on the source core. The sources with extremely good reproducibility and consistency with respect to activity content and other quality parameters could be produced.

The microstructures of plain silver wire and palladium coated silver wires are shown in Fig. 2 (a) and (b) respectively, indicating the presence of huge sites for sorption of iodine on palladium cated silver wires.

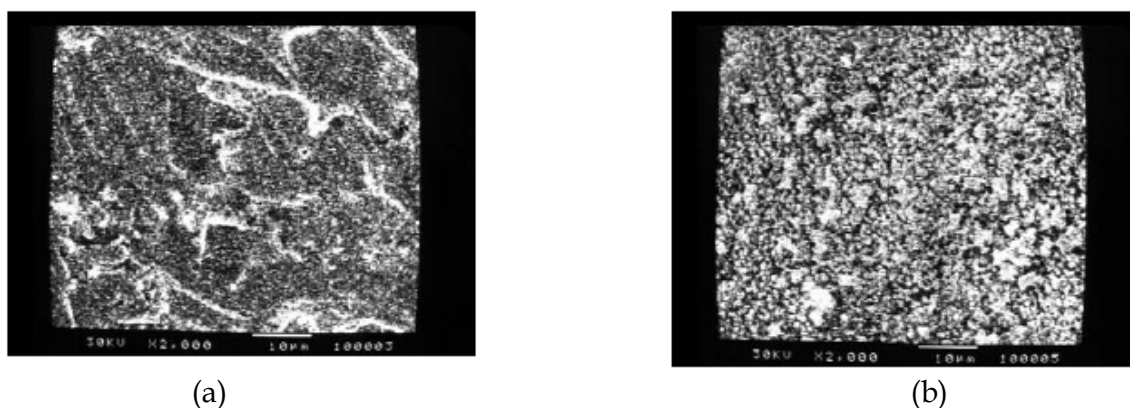

Fig. 2. (a) SEM of Plain Silver wire Fig. 2 (b) SEM of Palladium Coated Silver wire

### 5.1.5 Comparison of techniques

The electrodeposition method of preparing  $^{125}\text{I}$  source core is a straight forward procedure and used by many commercial manufacturers of these sources. Quantitative firm and uniform deposition could be obtained by the optimized parameters, with low leaching of activity. However this method is labour intensive, require high skill and would be exposing personnel to long time to radiation. The electro deposition method is attractive only if automated system where radioactive iodine is electrodeposited on a long piece of silver wire of the required diameter and subsequently precision cut in to the required dimensions by remotely operated electro mechanical cutting devices, is available.

The inherent drawbacks of absorption of  $^{125}\text{I}$  on a ceramic matrix and iodination of the silver rod, include a tedious time-consuming matrix preparation procedure, need for strict adherence to the operational protocol, and the requirement for well-trained, skilled operator.

Chemisorption of  $^{125}\text{I}$  activity on the  $\text{PdCl}_2$  treated silver wire as more suitable for adsorption of  $^{125}\text{I}$  than plain silver wires in terms of quantitative adsorption and non-leachability of  $^{125}\text{I}$  activity. The procedure is straightforward and easily performed. The workload to use this protocol is small. The incidence of serious error may be low. The mild experimental conditions of adsorption at neutral to alkaline pH facilitates the safe handling of high amounts of radioactivity for the preparation of therapeutic sources without the release of air activity. The stability of  $^{125}\text{I}$  on Pd coated silver wire is due to the formation of insoluble palladous iodide on the surface of the wire and accounts for low leachability. This procedure is routinely used by Radiopharmaceuticals Division, BARC, Mumbai. Fig. 3 depicts the laboratory used for the regular production of  $^{125}\text{I}$  source core.



Fig. 3. Laboratory for the production of  $^{125}\text{I}$  source core

### 5.2 Preparation of spherical type source cores

A linear assembly of six alumina microspheres or six palladium coated silver spheres of 0.5 mm( $\phi$ ) were used for making spherical seed sources.

### 5.2.1 Alumina microspheres

A mixture of pre-cooled ( $5^{\circ}\text{C}$ ) solution of hexamethylenetetraamine and urea (3 M) with aluminum nitrate solution was dispersed as droplets into hot oil to bring about the formation of aluminium hydroxide in to solid gel sphere form. The spheres were dried in an air oven at  $100^{\circ}\text{C}$  and heat treated at  $700^{\circ}\text{C}$  for 5 h in a furnace to obtain alumina spheres. Spheres of uniform sizes were selected by passing through a  $600\ \mu\text{m}$  mesh. The experimental conditions such as amount of radioactivity, carrier concentration, reaction time, reaction temperature, reaction volume etc. were systematically optimised. By this method, more than 95% of the initial radioactivity could be firmly deposited on the source core and 0.6-0.8 mCi of radioiodine could be adsorbed on the alumina microsphere [9].

### 5.2.2 Metallic microspheres

Silver beads of dimension of  $0.5\ \text{mm}(\phi)$  were pre-coated with palladium for the incorporation of radioiodine ( $^{125}\text{I}$ ). The experimental conditions such as amount of radioactivity, carrier concentration, reaction time, reaction temperature, reaction volume, pH of the reaction mixture, etc. were systematically optimized [16]. By this method, more than 83 % of the initial radioactivity could be irreversibly adsorbed on the palladium coated on the source core and radioactive sources in the range of 20-251 MBq ( 0.5-0.6 mCi) can be prepared. The sources with extremely good reproducibility and consistency w.r.t. activity content and other quality parameters could be produced. All the sources were measured with calibrated ionization chambers and seed strength was quoted with an overall uncertainty of  $\pm 10\%$ .

### 5.2.3 Comparison of techniques

The physicochemical adsorption of radioiodine on alumina microspheres is easy and also less expensive. Quantitative adsorption of activity on the spheres is possible by using radioactive iodine in iodate ( $\text{IO}_3^-$ ) form. However, it was found that the percentage leachability of radioactivity from the spheres was more than desirable. Further developments are needed to assess the potential of this approach on a reliable and continuous basis.

The physicochemical adsorption of Pd-silver microspheres is easy and  $^{125}\text{I}$ -beads could be prepared in a nonleachable form. The radioactive sources upto  $\sim 111\text{MBq}$  (3 mCi) activity can be prepared by arranging six individual beads in a well-arranged geometry.

## 6. Fabrication of titanium capsules

The capsule matrix should have chemical compatibility with the source core which will be encapsulated inside. The capsule material need to be of low atomic weight so that it would attenuate radiation to a minimum extent. Titanium's unique combination of attributes such as light weight, high strength to weight ratio, corrosion resistance, amenability for easy welding, biocompatibility, and durability in extreme environments make it an excellent material for capsule fabrication. Titanium is used extensively for medical and dental implants because it is biocompatible with the human body. It is completely inert and immune to corrosion by all fluids and tissues of the body, making it ideal for encapsulation. The wall thickness of the capsule should be adequate to provide requisite mechanical strength to retain the source core, in order to reduce the risk of radioactive contamination in



the event of source rupture during handling. At the same time it should not be too thick to attenuate the radiation emanating from the source. The wall thickness of the capsule is configured to provide adequate mechanical strength as well as required radiation output. About 0.05 mm thick titanium tubes is sufficient to allow gamma rays and low energy X-rays to pass through for providing therapeutic effect. It is preferred that the capsule have an open end and a closed end. The capsule is preferably sealed with a suitable end cap using techniques such as laser/electron beam welding.

The titanium Capsules of the required dimensions 4.75mm(l) x 0.8 mm( $\phi$ ) x 0.05mm(t) along with suitable caps(lids) of 0.8mm( $\phi$ ) are generally used. Fig.4 shows the cross-sectional view of titanium encapsulated wire source and microspheres.

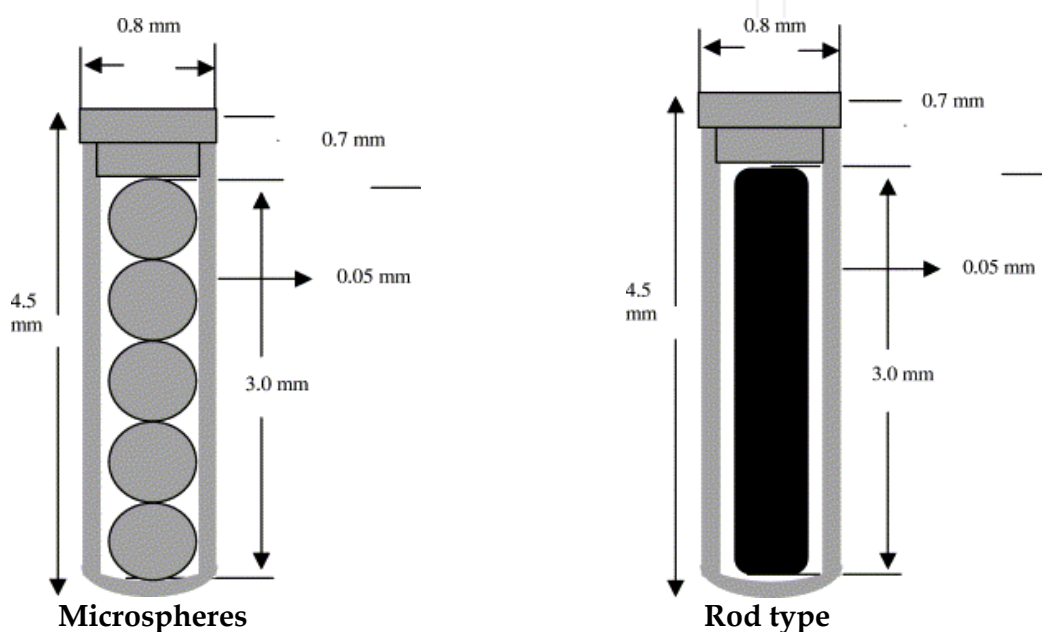

Fig. 4. Cross sectional view of encapsulated  $^{125}\text{I}$ - sources.

## 7. Laser welding of titanium capsules

The welding of capsules containing radioactive sources requires that the following conditions are met:

- The welding has to be carried out in a well ventilated shielded enclosure
- The process of welding should be feasible in a remotely operated system.
- The welding should not change the geometry of the capsules.
- Loss of activity during the welding should be minimum (minimum heat input to the active source)
- Efficiency of welding should be such that there should not be leakage of activity after welding. (Welding should cause less porosity)

The activities of the  $^{125}\text{I}$  rods/spheres were measured and the sources with activity within  $\pm 5\%$  of the targeted activity (generally 111 MBq/source) were segregated and used for encapsulation. The rods were inserted individually into the titanium capsule followed by placement of a cap over it with the aid of magnifying glass. The source loading procedure adapted in radiopharmaceuticals Division of Bhabha Atomic Research Center is depicted in Fig.5.



Fig. 5. Loading of  $^{125}\text{I}$  source core inside the capsules

Although the tungsten inert gas (TIG) process is the most common method for welding SS capsules, this is not suited to our type of application. TIG welding cause molten titanium to flow down and the weld was observed to be porous. The most likely cause of porosity is the trapping of gas bubbles between dendrites during solidification and presence of hydrogen from moisture in the arc environment. This resulted in the leakage of radioactivity from the welded capsules significantly higher than the prescribed limit. Hence an alternative method of welding is to be adopted.

In order to circumvent these problems, a pulsed laser welding system was used for the encapsulation of capsules. This system consists of a laser head, power supply unit, chiller unit and welding system. As the welding is carried out in pulses, the heat input to the  $^{125}\text{I}$  source is reduced. The Nd:YAG laser installed inside the fume-hood in our laboratory is shown in the Fig.6. The output of the laser is taken through the ports and it is connected to the welding head using optical fiber.



Fig. 6. Laser Welding System

Major advantages of laser beam welding are low welding stresses, low risk of distortion, creation of minimal heat affected zone with minimal  $^{125}\text{I}$  contamination and capability of welding of varying mass that allows hermetic sealing of Ti capsules. Nd:YAG pulsed lasers have the ability to weld hard materials like Ti and produce an aesthetic weld with high depth/width ratio free from any weld buildup that eliminates many secondary operations such as grinding or honing. It has also high welding speed, good reproducibility, flexibility and the process can be easily be remotized and automated. Due to the extreme reactivity of titanium metal, it is essential to shield the molten pool and the hot metal from contact with air. Argon is used as inert gas protection.

Prior to welding, the welding parameters such as energy of laser pulse, frequency, pulse duration and rotational speed of sample are systematically optimized to obtain quality welds with negligible leakage. The laser-welding operations were carried out remotely using PC-based controlled system. Fig. 7 depicts a typical welded  $^{125}\text{I}$ -seed.



Fig. 7. Encapsulated  $^{125}\text{I}$ - brachytherapy sources

The metallography test of welded capsules was carried out by optical metallography (The metallograph of a welded source is shown in Fig. 8).



Fig. 8. Optical micrograph (50 times magnified) of a welded capsule.

The penetration depth in the samples was evaluated by Scanning Electron Microscopy (SEM). The SEM micrograph is depicted in Fig. 9. The penetration depth was found to be  $\sim 2$ -3 times the wall thickness of the capsules. The welded samples showed high integrity and superior metallurgical quality.

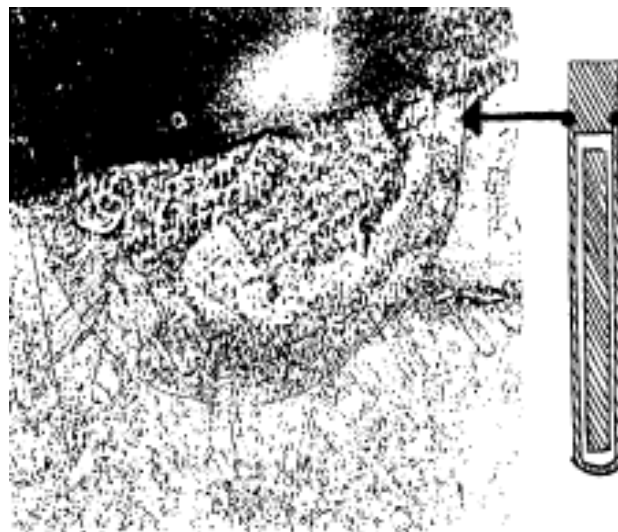

Fig. 9. SEM of welded capsule

## 8. Quality control of sealed sources

Quality is “the degree to which a set of inherent characteristics fulfils requirements.” Control is “the need or expectation that is stated, generally implied or obligatory.” Iodine-125 sources produced are subjected to numerous checks obligatory by regulatory authorities. The emphasis given is on the physical and chemical aspects. The schematic diagram of an assembly of laser welded  $^{125}\text{I}$  seed is shown in Fig. 10.

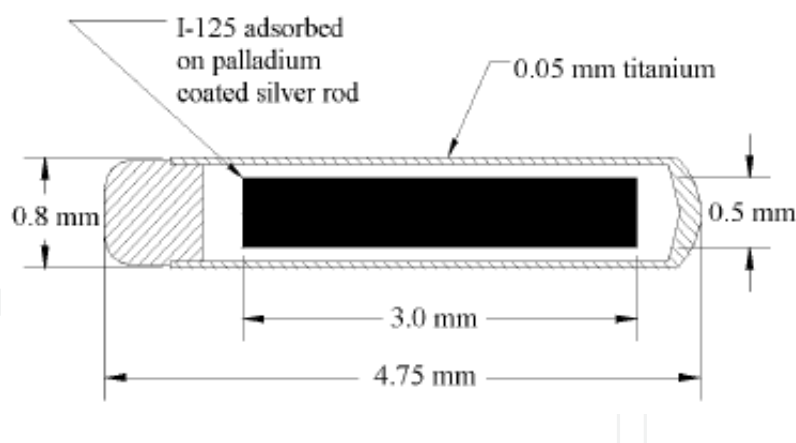

Fig. 10. Assembly of laser welded  $^{125}\text{I}$  seed

### 8.1 Source strength measurement

The estimation of source activity/ strength for the seed was carried out by using a calibrated well-type ionization chambers. The charge collected per unit time by keeping the source at the position of peak response in the well chamber was multiplied by the calibration factor to estimate the activity content of source. The factor recommended by AAPM for converting the strength of  $^{125}\text{I}$ -seeds from apparent activity (mCi) to source strength (i.e. air kerma strength) is 1.27 mGy/h-m<sup>2</sup> per mCi (irrespective of internal construction of the source) and

the same was used as a reference for the studies carried out at our end. A source calibration accuracy of  $\sim 3\%$  relative to existing air kerma standards seems reasonable. The radiation equipment should not be used whenever the level is exceeded.

### 8.2 Leachability

Source cores (Un-encapsulated) were immersed in 100 mL of still distilled water at ambient temperature for 48 hours. At the end of 48 hours, the total leached out radioactivity was assayed to determine the leachability of bare sources should be less than 0.01% of the total seed activity. The physico-chemical adsorption method [14] adapted by us was found to achieve this limit and thus complied with regulatory norms.

### 8.3 Swipe test

The sealed sources are tested for surface contamination or presence of any loose activity by swiping the sources using alcohol immersed cotton wool and checking the radioactive content in a NaI(Tl) scintillation counter. When the activities detected in the swipe is less than 185 Bq, the sealed source capsule is considered to be contamination free.

### 8.4 Uniformity of activity

Uniformity of deposition of  $^{125}\text{I}$  activity was examined by autoradiography using a specially designed gadget (Fig. 11.) A circular disc [4.4 cm ( $\phi$ ), 1.4cm thick] made of brass with a central hole of 3mm diameter and 8 mm depth was taken and eight equidistant tunnels (45° angle between each successive tunnels) of uniform aperture were drilled through the central hole. One source was placed at a time in the central hole and autoradiographed simultaneously by wrapping a strip of photographic film all along the side of brass disc.



Fig. 11. Gadget for Auto-radiography

The film gets exposed from eight equidistant directions through the holes. The Optical density distribution of the exposed film at different angles was measured by B/W transmission densitometer. The variation in OD values at different positions should be  $\pm 10\%$ . Sources prepared by the physico-chemical adsorption methodology [14] in our laboratory has variation within  $\pm 5\%$  (Fig.12).



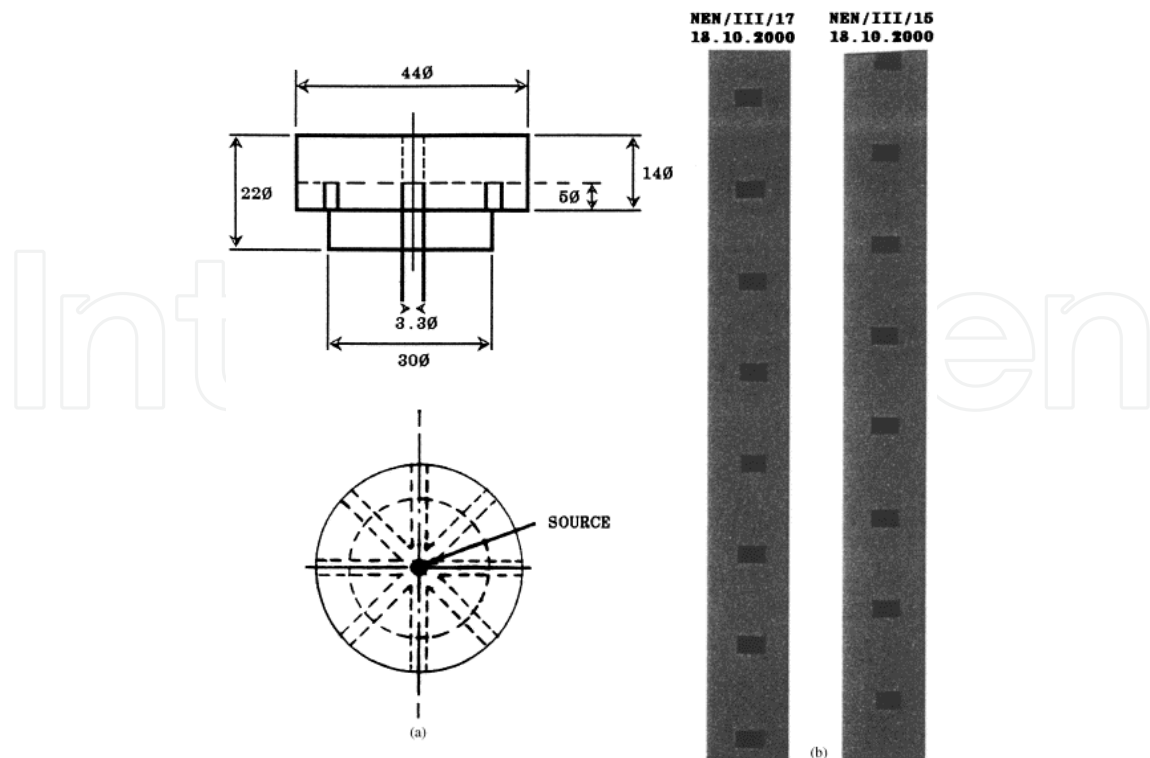

Fig. 12. (a) Specially designed autoradiography gadget; b) developed autoradiography film of the sources.

### 8.5 Leakage test

It was mandatory to check all the sealed sources to ascertain leak tightness of the sealing. The following tests are performed on all the sources.

#### *Bubble test*

The fabricated sealed sources are placed in nearly boiling water kept in a glass beaker for about 2 minutes. Appearance of bubbles from the sealed sources indicates improper sealing and such sources are discarded.

#### *Pressure test*

The fabricated sealed sources are immersed in a closed glass container containing ethylene glycol and the pressure inside the chamber is reduced to 100 mm of Hg. Any leak from the sources is shown by a string of bubbles, and such sources are rejected.

### 8.6 Immersion test

One sealed source is immersed in 20 mL of water taken in a glass beaker and heated to 50°C for 5 hours. The source is removed, the water concentrated to 1mL and the activity released is estimated in a well type NaI(Tl) counter. Activity measuring 185 Bq /source is considered to be the limit for acceptance of leak tightness. When the activities detected in the immersion test of the sealed source is less than 185 Bq, the sealed source capsule is considered to be leak tight.

The following steps should be taken during Quality Control of  $^{125}\text{I}$  seeds.

- i. The surface of each source must be checked regularly for visible damage. Sources with damaged surface must not be touched for wipe test.

- ii. All quality control results must be documented.
- iii. For each type of test separate instrument should be used.
- iv. Ion chamber used for measuring activity should be used solely for that purpose only and should be kept separately.
- v. Swipe test should be carried out using a dedicated surface contamination detector which can easily show even the smallest amount of radioactive material. The table used for keeping the surface contamination detector must be separated from the source preparation laboratory. The instruments may get contaminated and must be decontaminated regularly. The verification of the absence of radiation in the surface contamination detector should be a routine task.

## 9. Classification performance testing

For use of radioactive seeds in interstitial applications, where sources of higher radioactive strength of the order of 30 GBq to 370 GBq and comprising of radiologically more hazardous and longer lived radionuclides such as  $^{137}\text{Cs}$ ,  $^{192}\text{Ir}$  etc. are used, the integrity of sources upto a temperature of  $600^\circ\text{C}$  is necessarily evaluated. In case of  $^{125}\text{I}$ -seeds, the strength of a typical implant of 100 seeds is very low ( 1.85-3.7 GBq) as compared to the strength of  $^{137}\text{Cs}$  or  $^{192}\text{Ir}$  sources. However, the volatile nature of iodine makes the source vulnerable to air borne release of radioactivity at higher temperature exposure conditions. In view of the low levels of radioactivity, low radiotoxicity and less risk of accidents or hazards associated with  $^{125}\text{I}$ -seeds, the exemption for test at  $600^\circ\text{C}$  seeds was sought from Atomic Energy Regulatory Board, India.  $^{125}\text{I}$ -seeds were tested upto  $400^\circ\text{C}$ , a temperature that was experimentally found to release the radioactivity within the permissible levels of 185 Bq. Release of radioactivity from sources after subjecting them to various classification performance evaluation tests was found to be well within the permissible level of 185 Bq and the source design was approved by Atomic Energy Regulatory Board, India under class C-43211. Classification performance testing of indigenous  $^{125}\text{I}$ -seeds was carried out for ensuring their safety in brachytherapy applications [17] and following tests were performed.

### 9.1 Temperature and thermal shock tests

Sealed sources were tested for their integrity under extreme temperature as well as quick changes in temperature. Two sources are heated to of  $400^\circ\text{C}$  in a controlled manner and kept at this temperature for one hour. Two other sources are heated to  $400^\circ\text{C}$  for 15 minutes and then quenched to  $20^\circ\text{C}$ . Two other sources are cooled to  $-40^\circ\text{C}$  and kept at this temperature for 20 minutes. All these sources are subjected to tests for leakage in hot water and surface contamination as described above. When the activities detected are less than 185 Bq, the sealed source pass this test.

### 9.2 Pressure test

In order to assess the strength of the sources to withstand extreme pressures, two sealed sources are subjected to a pressure of 2 MPa. In a separate set-up, two sources are subjected to a vacuum of 25 kPa. After repeating two cycles of both these tests for 5 minutes, tests for leakage in hot water and surface contamination are carried out. When the activities detected in the swipe as well as in water are less than 185 Bq, the sealed sources were consider withstanding extreme pressures.

### 9.3 Impact test

In order to evaluate the ability of the sealed source to withstand high impacts, a steel billet of 50 grams weight is dropped over the sealed sources from a height of one meter. The integrity the sealed source is then examined by visual examination as well as conducting leakage tests and surface contamination tests. If a wipe test or leakage tests detects less than 185Bq (0.005  $\mu\text{Ci}$ ) of removable radioactive material, the sealed sources are consider withstanding high impacts.

## 10. Radiological safety

In view of radioactive nature of  $^{125}\text{I}$ , safe and appropriate radioactive procedures should be adopted during the whole preparation process. Although gamma/X-ray emanating from  $^{125}\text{I}$  have little penetrating power, they are hazardous if  $^{125}\text{I}$  is ingested or inhaled. For this reason, it is recommended to wear protective clothing and safety glasses when working with  $^{125}\text{I}$ . Radiation monitoring of personnel should be accomplished with TLD dosimeters worn while working. The room or area used for the preparation of  $^{125}\text{I}$  sources must be posted with a sign having the words "Caution - Radioactive Materials". Ventilation of the source preparation laboratory should be sufficient to quickly reduce the presence of gaseous radioactive products. It is useful to locate a surveillance monitor in the source preparation laboratory which can give a warning signal if there is significant increase in the radiation level resulting from radioactive contamination on the work place. The sensitivity of the monitor should be easily adjustable. The ALARA principle should be observed with regard to the radiation exposure of the operating staff. Reduction of the dose during the preparation of  $^{251}\text{I}$ -brachytherapy sources can be achieved by a combination of the following principles:

- i. Reduce the time of exposure during handling of activity, as the total dose is proportional with time. Materials and equipment used for source preparation must be set ready. Procedures must be practiced with non-active, dummy material to gain experience.
- ii. Keep the distance as large as possible. Radioactive materials should not be touched by hand. It is recommended to use long forceps or tweezers to handle the source cores. The inverse square law is the most effective method of dose reduction.
- iii. Reduce the amount of radioactive materials handling as far as possible. Measures must be taken to reduce the exposure from the radioactive materials not used for source preparation. Each source must be subjected quality control separately, while any other source is stored in a shielded container and set aside at some distance.
- iv. Use the shielding material that is available. Examples are the shields at the preparation hood or movable shields besides the ion chamber.

Radioactive sources cannot be left in the laboratory hood. All fabricated sources must be registered. The register must contain information on the activity on a given date and eventually the batch number and the results of the QC checks. The sources have to be locked away safely in a storage container. The radiation level at 1 m from the container surface should be less than 1  $\text{mSv} \cdot \text{h}^{-1}$  and at the surface less than 2  $\text{mSv} \cdot \text{h}^{-1}$ . Storage containers must be fire resistant and carefully locked when in use to prevent access by unauthorized persons. The radiation symbols should be clearly visible on each container. A logbook must show the date of dispatch and the destination of the sources such as user's address.

## 11. Conclusion

The technique of permanent seed implantation in management of prostate carcinoma is historically proven and is being widely used in many advanced countries. Modern transrectal ultrasound-guided, interstitial permanent brachytherapy is a single outpatient treatment for the majority of men with early-stage prostate cancer. It has documented five- and ten-year biochemical, overall, and disease-specific relapse-free survival rates that equal the best that radical prostatectomy has thus far achieved. These favorable findings have established permanent prostate brachytherapy as a primary treatment option for early stage prostate cancer.

The potential utility of various methods for the preparation of  $^{125}\text{I}$ -brachytherapy sources for prostate cancer have been documented. Quality control of  $^{125}\text{I}$ -brachytherapy sources after preparation is an important part. Many publications give recommendations on frequencies of quality control procedures without describing the procedures. It is, however, of extreme importance for the general process of quality assurance that these procedures are well defined and understood by the source manufactures. The quality control procedure depicted in this manuscript can be applied universally irrespective of the source preparation method adapted. The procedures presented here are a set of minimum requirements and can serve as guidelines for developing a QC protocol. It should be noted, however, that if any national set of requirements exists, these should be followed. It is envisaged that any one of the source preparation strategy would serve for ensuring easy availability  $^{125}\text{I}$ -brachytherapy sources particularly in Institution with Radiochemistry Laboratory facility where commercial sources are too expensive. Availability  $^{125}\text{I}$ -brachytherapy sources at local level would promote the beneficial use of permanent seed implantation technique.

## 12. Acknowledgements

The authors express their gratitude to all who have contributed in the preparation of this chapter. The authors are highly grateful to Prof. M. R. A. Pillai, Head, Radiopharmaceuticals Division for his keen interest, guidance, encouragement, valuable scientific discussions and support. The authors also wish to thank Dr. Meera Venkatesh, former Head, Radiopharmaceuticals Division for her encouragement and administrative support. The authors wish to thank Prof. V. Venugopal, Director, Radiochemistry and Isotope Group and Prof. K.L. Ramkumar, Associate Director, Radiochemistry and Isotope Group for their administrative support. The authors are indebted to their ex-colleagues Mr. S.A. Balakrishnan, Dr. M.A. Majali, Mr. C. Mathew who have started the work and brought to the this shape. The authors also thanks Mr. P. Sreeramakrishnan and Mr. A.S. Tapase of Isotope Applications Division, BARC for their contribution in the autoradiography analysis, Mr. K.C. Sahoo and Mr. E. Ramadasan of Post Irradiation Examination Division, BARC for the metallography analysis of welded capsules, Dr. K.T. Pillai, Fuel Chemistry Division for his contribution in making the alumina microspheres, Dr. C.G.S. Pillai, Chemistry Division, BARC for his contribution in the SEM analysis. The authors are grateful to Dr. (Mrs.) A. Shanta and Dr. S.D. Sharma of Radiological Physics & Advisory Division of our Institute for establishing clinical dosimetric parameters. The authors are grateful to the Engineers of Centre for Design and Manufacture for undertaking the fabrication of titanium capsules.

### 13. References

- [1] Localized Prostate Cancer-Patrick C. Walsh, Theodore L. DeWeese, and Mario A. Eisenberger- *N Engl J Med* 2007;357:2696-705.
- [2] Prostate Cancer Brachytherapy: Clinical and Financial Imperatives for Permanent Implantation, in *Oncology Roundtable Annual Meeting*. Washington, D.C., The Advisory Board Co., 2000, p 15
- [3] Porter AT, Blasko JC, Grimm PD, Reddy SM, Ragde H: Brachytherapy for prostate cancer. *CA Cancer J Clin* 1995; 45:165-78
- [4] Scardino P, Carlton C: Combined interstitial and external irradiation for prostatic cancer, in *Principles and Management of Urologic Cancer*. Edited by Javadpour N. Baltimore, Williams & Wilkins, 1983, pp 392-408.
- [5] Whitmore WF, Jr., Hilaris B, Grabstald H: Retropubic implantation to iodine 125 in the treatment of prostatic cancer. *J Urol* 1972; 108:918-20 19. Blasko JC, Grimm PD, Ragde H: Brachytherapy and organ preservation in the management of carcinoma of the prostate. *Semin. Radiat. Oncol.* 1993; 3:240-249
- [6] Puthawala A, Syed A, Tansey L: Temporary iridium implant in the management of carcinoma of the prostate. *Endocurie Hyper Oncol* 1985; 1:25-33
- [7] Holm HH, Juul N, Pedersen JF, Hansen H, Stroyer I: Transperineal I-125iodine seed implantation in prostatic cancer guided by transrectal ultrasonography. *J Urol* 1983; 130:283-286
- [8] Blasko JC, Radge H, Schumacher D: Transperineal Percutaneous Iodine-125 Implantation For Prostatic Carcinoma Using Transrectal Ultrasound and Template Guidance. *Endocurietherapy Hyperthermia Oncol* 1987; 3:131-139
- [9] R. B. Manolkar, S. U. Sane, K. T Pillai, M. A. Majali, Comparison of methods for preparation of 125I brachytherapy source cores for the treatment of eye cancer, *Applied Radiation and Isotopes*, Volume 59, Issues 2-3, August-September 2003, Pages 145-150
- [10] Izabela Cieszykowska, Andrzej Piasecki, Mieczysław Mielcarski, An approach to the preparation of iodine-125 seed-type sources, *NUKLEONIKA* 2005;50(1):17-22
- [11] Chunfu Zhang, Yongxian Wang, Haibin Tian, Duan Zhiyin Preparation of iodine-125 seed, Part I: Iodination of the silver rod, *Journal of Radioanalytical and Nuclear Chemistry*, Vol. 252, No. 1 (2002) 161-163
- [12] H. S. Han, U. J. Park, A. Dash, The absorption of iodine-131 on a ceramic matrix, *Journal of Radioanalytical and Nuclear Chemistry*, Vol. 262, No. 3 (2004) 703-705.
- [13] U. J. Park, J. S. Lee, K. J. Son, H. S. Han and S. S. Nam, The adsorption of 125I on a Ag+Al<sub>2</sub>O<sub>3</sub> rod as a carrier body for a brachytherapy source, *Journal of Radioanalytical and Nuclear Chemistry*, Vol. 277, No. 7 (2008) 429-432.
- [14] Saxena SK, Shanta A., Rajurkar Nilima S, Majali MA, Studies on the production and quality assurance of miniature 125 I radioactive sources suitable for treatment of ocular and prostate cancers. *Appl. Radiat. Isot.* 2006; 64: 441-447.
- [15] Mathew C., Majali MA, Balakrishnan SA., A novel approach for the adsorption of 125I on silver wire as matrix for brachytherapy for the treatment of eye and prostate cancer. *Appl. Radiat. Isot.* 2002; 57:359-367.
- [16] Sanjay Kumar Saxena, S.D.Sharma, Ashutosh Dash, Meera Venkatesh, Development of a new design 125I-brachytherapy seed for its application in the treatment of eye and prostate cancer *Applied Radiation and Isotopes*, 67 (2009) 1421-1425



- [17] Saxena S.K.,Yogendra Kumar, Manoj Kumar, Ashutosh Dash and Meera Venkatesh (2008),Quality Assurance and Classification Performance Testing of <sup>125</sup>I-brachytherapy Seeds, Proceedings of International Conference on Medical Physics (ICMP-2008) ,49-50
- [18] Regulations for the Safe transport of Radioactive material, 2005 Edition, International Atomic Energy Agency (IAEA) No. TS-R-1
- [19] International Standard ISO 2919:1999, Radiation protection- Sealed radioactive sources- General requirements and classification
- [20] International Standard ISO 9978:1992, Radiation protection-Sealed radioactive sources- Leakage test methods

IntechOpen

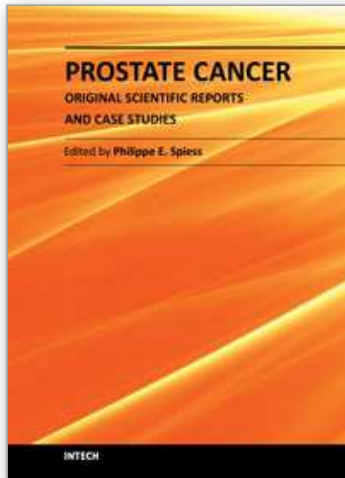

## **Prostate Cancer - Original Scientific Reports and Case Studies**

Edited by Dr. Philippe E. Spiess

ISBN 978-953-307-342-2

Hard cover, 238 pages

**Publisher** InTech

**Published online** 21, November, 2011

**Published in print edition** November, 2011

This book encompasses three sections pertaining to the topics of cancer biology, diagnostic markers, and therapeutic novelties. It represents an essential resource for healthcare professionals and scientist dedicated to the field of prostate cancer research. This book is a celebration of the significant advances made within this field over the past decade, with the hopes that this is the stepping stone for the eradication of this potentially debilitating and/or fatal malignancy.

### **How to reference**

In order to correctly reference this scholarly work, feel free to copy and paste the following:

Sanjay Kumar Saxena and Ashutosh Dash (2011). Development of Miniature 125I - Seeds for the Treatment of Prostate Cancer, Prostate Cancer - Original Scientific Reports and Case Studies, Dr. Philippe E. Spiess (Ed.), ISBN: 978-953-307-342-2, InTech, Available from: <http://www.intechopen.com/books/prostate-cancer-original-scientific-reports-and-case-studies/development-of-miniature-125i-seeds-for-the-treatment-of-prostate-cancer>

**INTECH**  
open science | open minds

### **InTech Europe**

University Campus STeP Ri  
Slavka Krautzeka 83/A  
51000 Rijeka, Croatia  
Phone: +385 (51) 770 447  
Fax: +385 (51) 686 166  
[www.intechopen.com](http://www.intechopen.com)

### **InTech China**

Unit 405, Office Block, Hotel Equatorial Shanghai  
No.65, Yan An Road (West), Shanghai, 200040, China  
中国上海市延安西路65号上海国际贵都大饭店办公楼405单元  
Phone: +86-21-62489820  
Fax: +86-21-62489821

© 2011 The Author(s). Licensee IntechOpen. This is an open access article distributed under the terms of the [Creative Commons Attribution 3.0 License](#), which permits unrestricted use, distribution, and reproduction in any medium, provided the original work is properly cited.

IntechOpen

IntechOpen