

We are IntechOpen, the world's leading publisher of Open Access books Built by scientists, for scientists

4,800

Open access books available

122,000

International authors and editors

135M

Downloads

Our authors are among the

154

Countries delivered to

TOP 1%

most cited scientists

12.2%

Contributors from top 500 universities



WEB OF SCIENCE™

Selection of our books indexed in the Book Citation Index
in Web of Science™ Core Collection (BKCI)

Interested in publishing with us?
Contact book.department@intechopen.com

Numbers displayed above are based on latest data collected.

For more information visit www.intechopen.com



LMI Robust Control of PWM Converters: An Output-Feedback Approach

Carlos Olalla¹, Abdelali El Aroudi¹, Ramon Leyva¹ and Isabelle Queinnec²

¹Universitat Rovira i Virgili, 43007 Tarragona

²CNRS ; LAAS ; 7 avenue du colonel Roche, F-31077 Toulouse Cedex 4

Université de Toulouse ; UPS, INSA, INP, ISAE, UT1, UTM ;

LAAS ; F-31077 Toulouse Cedex 4

¹Spain

²France

1. Introduction

This chapter proposes a systematic approach for the synthesis of robust controllers for dc-dc converters. The approach is based on the Linear Matrix Inequalities (LMIs) framework and the associated optimization algorithms. The aim of this approach is to allow the designer to describe the uncertainty of the converter and to deal with the requirements of the application beforehand.

The aforementioned dc-dc converters (see Figure 1) are devices that deliver a dc output voltage, with different properties from those in the input voltage (Erickson & Maksimovic, 1999). They are usually employed to adapt energy sources to the load requirements (or vice versa). These devices present several challenges regarding their robust control. First, the converter must maintain a tight regulation or tracking of the output. Moreover, the controller design is focused on maximizing the bandwidth of the closed-loop response in order to reject the usual disturbances that appear in these systems. Finally, the response of the converter must satisfy desirable transient characteristics, as for example, the shortest possible output settling time or the minimum overshoot. Besides of these common requirements, the converter can be affected by uncertainty in its components or by input or output disturbances that may appear.

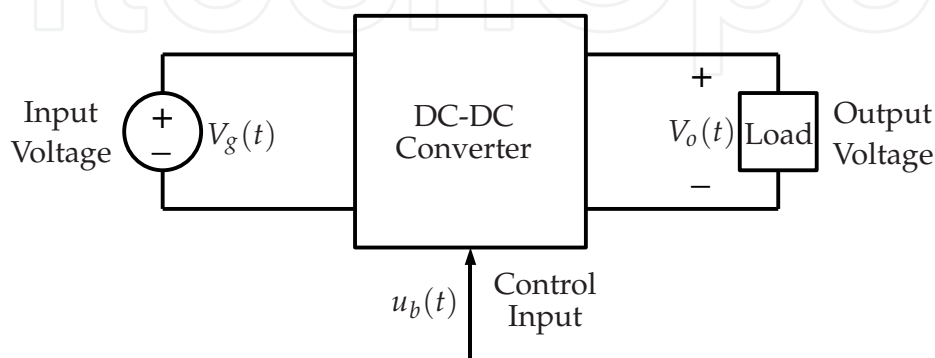
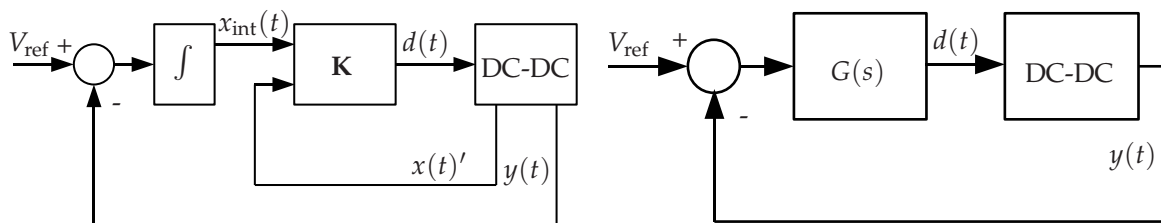

Fig. 1. General scheme of a dc-dc converter.



(a) Block diagram of a state-feedback system with controller \mathbf{K} and error integration. (b) Block diagram of an output-feedback system with controller $G(s)$.

Fig. 2. State-feedback and output-feedback block diagrams.

Nevertheless, most of the modeling approaches in the literature disregard these uncertainties. Moreover, due to the switching nature of the system, pulse-width modulation (PWM) is commonly used in the industry applications, while the models that are usually employed disregard that part of the dynamics (i.e. the high frequency dynamics) and other inherent nonlinearities, such as saturations and bilinear terms.

The chapter proposes a systematic approach to deal with these challenges, using the concepts of LMI control (Ben-Tal et al., 2009; Bernussou, 1996; Boyd et al., 1994; El Ghaoui & Niculescu, 2000; Pyatnitskii & Skorodinskii, 1982). Linear matrix inequalities have become an important topic in the field of Automatic Control due to the following facts. First of all, LMIs can be solved numerically by efficient computer algorithms (Gahinet et al., 1995; Löfberg, 2004; Sturm, 1999). Secondly, more and more methods have been developed to describe control problems in terms of LMI constraints. Finally, these methods are able to include descriptions of the uncertainty.

Some of the previous literature on LMI control of dc-dc converters are (Montagner et al., 2005; Olalla et al., 2009a; 2010a). In these papers, the uncertainty of the converter is taken into account and the control synthesis deals with different operating points. Nevertheless, they do not consider the stability of the system trajectories when the system changes from one operating point to another, nor they include other nonlinearities such as saturations. The versatility of LMI control has allowed to deal with some of these nonlinearities (Olalla et al., 2009b), (Olalla et al., 2011).

These approaches share the same feedback scheme, which is based upon state-feedback with error integration (Figure 2(a)). The main advantage of this approach is that the synthesis optimization problem can be posed as a convex semidefinite programming and that the implementation of the controller is simple. On the other hand, state-feedback requires sensing of the state variables, which may not be easily measurable or may require estimation in some cases. In practice, most of the designs that can be found in the power electronics literature employ output-feedback approaches since they usually rely on frequency-based concepts which are well-known by electrical engineers. This is the reason why this chapter focuses on LMI-based synthesis methods which may be applicable to the output-feedback scheme (Figure 2(b)), with the aim to derive robust controllers for dc-dc converters.

In order to introduce such synthesis methods, the chapter is organized as follows. The first section deals with modeling of dc-dc converters, the averaging method, the sampling effect of the pulse-width modulator and the uncertainty. Section II reviews some of the results of previous works on LMI synthesis for state-feedback approaches. Section III puts forward the problem of output-feedback and some of the strategies that can be employed to pose such problem in terms of semidefinite programming. Concretely, Section III proposes the

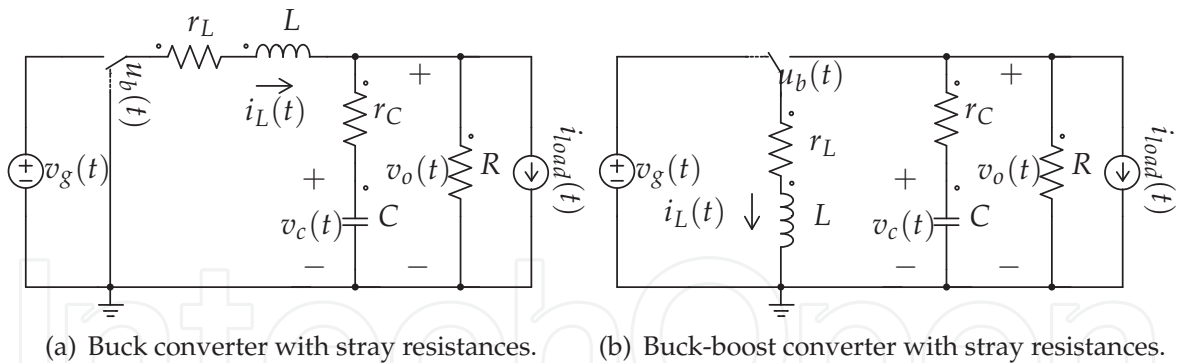

Fig. 3. Schematic of the buck and the buck-boost converter.

following strategies. First, the classic dynamic output-feedback control problem is treated. This approach can be carried out with a change of variables as in (Scherer et al., 1997). However, with such an approach the uncertainty must be modeled with elaborated models, as for example, weighting functions Wallis & Tymerski (2000). Therefore, the chapter also proposes the synthesis of output-feedback controllers based on the static case. Both the static output-feedback and a parametrization (Peaucelle & Arzelier, 2001b) to deal with dynamic output-feedback are considered. The advantages and drawbacks of the three approaches shown in the chapter will be discussed and the results will be compared.

Notation

For symmetric matrices A and B , $A > B$ means that $A - B$ is positive definite. \mathbf{A} denotes that the matrix A is an unknown variable. A' denotes the transpose of A . $\text{Co}\{v_j, j = 1, \dots, N\}$ denotes the convex hull defined by N vertices $v_j \in \mathbb{R}^n$. The identity matrix of order n is noted as $\mathbf{1}_n$ and the null $n \times m$ matrix is noted as $\mathbf{0}_{n,m}$. The symbol \star denotes symmetric blocks in partitioned matrices.

2. Modeling of uncertain dc-dc converters

This subsection shows the state-space averaged models of the buck and the buck-boost converters of Figures 3(a) and 3(b). The models are assumed to operate in Continuous Conduction Mode (CCM), i.e. the inductor current is always larger than zero. Besides of the averaged models, this section also introduces a model of the sampling effect caused by the PWM. Finally, at the end of the section, the uncertainty modeling of dc-dc converters is discussed and a simple example is shown.

2.1 Model of the buck converter

The first model that is introduced considers a buck converter, which is characterized by linear averaged control-to-output dynamics. As stated in (Olalla et al., 2010b), the transfer functions of dc-dc converters can strongly depend on the stray resistances of the converter. Since the chapter considers different output-feedback synthesis approaches, these stray resistances are considered in the models.

Figure 3(a) shows the circuit diagram of a dc-dc buck converter where $v_o(t)$ is the output voltage, $v_g(t)$ is the line voltage and $i_{\text{load}}(t)$ is the load disturbance. The output voltage must be kept at a given reference V_{ref} . The converter load is modeled as a linear resistor R . The stray resistances of the switch during the on and the off position are combined with the resistance

of the inductor and noted as:

$$\begin{aligned} r_{on} &= r_{d_{on}} + r_L \\ r_{off} &= r_{d_{off}} + r_L \end{aligned} \quad (1)$$

The measurable states of the converter are noted as $x_a(t)$. Note that the time dependence of the variables may be omitted to simplify the notation.

The binary signal $u_b(t)$, which turns on and off the switches, is generated by means of a Pulse Width Modulation (PWM) subcircuit, working at a constant frequency $1/T_s$. The switching period T_s is equal to the sum of t_{on} and t_{off} . For a unit-amplitude sawtooth PWM, the duty-cycle $d(t) = t_{on}/(t_{on} + t_{off})$ is the control input of the converter.

As shown in (Erickson & Maksimovic, 1999) and (Leyva et al., 2006), considering that the state-space matrices of the converter are $[A_{on}, B_{on}]$ during t_{on} and $[A_{off}, B_{off}]$ during t_{off} , the general state-space averaged model of a dc-dc converter can be written as:

$$\begin{aligned} \dot{\hat{x}}(t) &= (A_{off} + (A_{on} - A_{off})U)X + (B_{off} + (B_{on} - B_{off})D) \begin{bmatrix} 1 \\ 0 \end{bmatrix} W \\ &\quad + (A_{off} + (A_{on} - A_{off})U)\tilde{x}(t) + (B_{off} + (B_{on} - B_{off})D) \begin{bmatrix} 0 \\ 1 \end{bmatrix} \tilde{w}(t) \\ &\quad + ((A_{on} - A_{off})X + (B_{on} - B_{off}) \begin{bmatrix} 1 \\ 0 \end{bmatrix} W)\tilde{d}(t) \\ &\quad + ((A_{on} - A_{off})\tilde{x}(t) + (B_{on} - B_{off}) \begin{bmatrix} 0 \\ 1 \end{bmatrix} \tilde{w}(t))\tilde{d}(t), \end{aligned} \quad (2)$$

where the equilibrium (noted with capital letters) and the incremental vectors (noted with tildes) are as follows. X and $\tilde{x} \in \mathbb{R}^n$ correspond to the state vectors, D and $\tilde{d} \in \mathbb{R}^m$ are the control inputs, while W and $\tilde{w} \in \mathbb{R}^l$ stand for the disturbance inputs.

In the buck converter, $A_{on} = A_{off}$, and the averaged model (2) can be rewritten as:

$$\frac{d\tilde{x}(t)}{dt} = (AX + B_w W) + A\tilde{x}(t) + B_w \tilde{w}(t) + B_u \tilde{d}(t) + B_{n_w} \tilde{w}(t)\tilde{d}(t) \quad (3)$$

where:

$$A = \begin{bmatrix} -\frac{r_{eq}}{L} - \frac{Rr_C}{(R+r_C)L} & -\frac{R}{(R+r_C)L} \\ \frac{R}{(R+r_C)C} & -\frac{1}{(R+r_C)C} \end{bmatrix}, B_w = \begin{bmatrix} \frac{D}{L} & \frac{Rr_C}{(R+r_C)L} \\ 0 & -\frac{1}{(R+r_C)C} \end{bmatrix},$$

$$B_u = \begin{bmatrix} \frac{V_g}{L} \\ 0 \end{bmatrix}, B_{n_w} = \begin{bmatrix} \frac{1}{L} \\ 0 \end{bmatrix}, \quad (4)$$

$$X = \begin{bmatrix} \frac{V_g D}{1 + r_{eq}/R} \\ \frac{R}{V_g D} \\ \frac{1}{1 + r_{eq}/R} \end{bmatrix}, W = \begin{bmatrix} V_g \\ 0 \end{bmatrix}, \tilde{x}(t) = \begin{bmatrix} \tilde{i}_L(t) \\ \tilde{v}_o(t) \end{bmatrix}, \tilde{w}(t) = \begin{bmatrix} \tilde{v}_g(t) \\ \tilde{i}_{load}(t) \end{bmatrix},$$

being $r_{eq} = Dr_{on} + D'r_{off}$ and $D' = 1 - D$. The dimensions of the system matrices are defined as $A \in \mathbb{R}^{n \times n}$, $B_u, B_{n_w} \in \mathbb{R}^{n \times m}$, $B_w \in \mathbb{R}^{n \times l}$.

Similarly, the averaged outputs of the buck converter can be written as:

$$Y + \tilde{y}(t) = (C_y X + E_{yw} W) + C_y \tilde{x}(t) + E_{yw} \tilde{w}(t) \quad (5)$$

where in a general case $C_y \in \mathbb{R}^{q \times n}$, $E_{yw} \in \mathbb{R}^{q \times m}$. Considering the load voltage $v_o(t)$ as the only output, these matrices are written as:

$$C_y = \begin{bmatrix} \frac{Rr_C}{R+r_C} & \frac{R}{R+r_C} \end{bmatrix}, E_{yw} = \begin{bmatrix} 0 & -\frac{Rr_C}{R+r_C} \end{bmatrix}. \quad (6)$$

2.2 Model of the buck-boost converter

In the buck-boost converter, matrices A_{on} and A_{off} are not equal, and therefore, the averaged model contains bilinear terms concerning the control input, the states and the disturbance inputs. According to those nonlinear terms, the linearized transfer function depends on the operating point, hence making the control subsystem design more difficult. In order to derive accurate transfer functions of the buck-boost converter for output-feedback approaches, the stray resistances are also taken into account.

For the buck-boost converter, the averaged model in the form of (3) contains bilinear terms, and can be expressed as follows:

$$\frac{d\tilde{x}(t)}{dt} = (AX + B_w W) + A\tilde{x}(t) + B_w \tilde{w}(t) + B_u \tilde{d}(t) + B_{n_x} \tilde{x}(t) \tilde{d}(t) + B_{n_w} \tilde{w}(t) \tilde{d}(t) \quad (7)$$

where:

$$A = \begin{bmatrix} -\frac{r_{eq}}{L} - D' \frac{Rr_C}{(R+r_C)L} & D' \frac{R}{(R+r_C)L} \\ -D' \frac{R}{(R+r_C)C} & -\frac{1}{(R+r_C)C} \end{bmatrix}, B_w = \begin{bmatrix} D \frac{1}{L} - D' \frac{Rr_C}{(R+r_C)L} \\ 0 & -\frac{R}{(R+r_C)C} \end{bmatrix},$$

$$B_u = \begin{bmatrix} \frac{V_g}{L} \left(1 + \frac{Dr_C}{D'^2(R+r_C)} + \frac{D'DR^2}{D'R(D'R+r_C) + (R+r_C)r_{eq}} \right) \\ \frac{DV_g}{CD'^2(R+r_C)} \end{bmatrix},$$

$$B_{n_w} = \begin{bmatrix} \frac{1}{L} - \frac{Rr_C}{(R+r_C)L} \\ 0 & 0 \end{bmatrix},$$

$$X = \begin{bmatrix} \frac{V_g D' DR (R+r_C)}{(-D'R(-D'R-r_C) + (R+r_C)r_{eq}) D'R} \\ \frac{-V_g D' DR (R+r_C)}{-D'R(-D'R-r_C) + (R+r_C)r_{eq}} \end{bmatrix}, B_{n_x} = \begin{bmatrix} \frac{Rr_C}{L(R+r_C)} & -\frac{R}{(R+r_C)L} \\ \frac{R}{(R+r_C)C} & 0 \end{bmatrix}. \quad (8)$$

being $r_{eq} = Dr_{on} + D'r_{off}$. The dimensions of the system matrices are defined as $A, B_{n_x}, B_{n_w} \in \mathbb{R}^{n \times n}$, $B_u \in \mathbb{R}^{n \times m}$, $B_w \in \mathbb{R}^{n \times l}$.

The averaged output $v_o(t)$ of the buck-boost converter can be written as:

$$Y + \tilde{y}(t) = (C_y X + E_{yw} W) + C_y \tilde{x}(t) + E_{yw} \tilde{w}(t) + C_{y_u} X \tilde{d}(t) + C_{y_u} \tilde{x}(t) \tilde{d}(t) \quad (9)$$

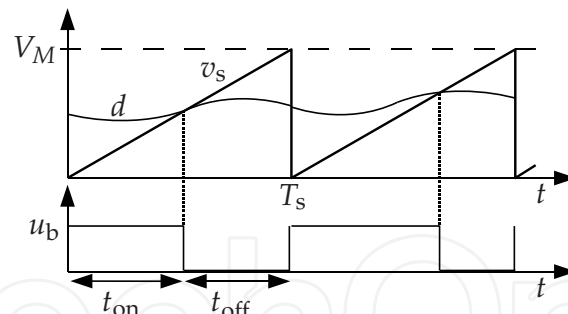

Fig. 4. Waveforms of the PWM process.

where:

$$C_y = \left[-D' \frac{Rr_C}{R+r_C} \quad \frac{R}{R+r_C} \right], \quad C_{yu} = \left[\frac{Rr_C}{R+r_C} \quad 0 \right], \quad E_{yw} = \left[0 \quad -\frac{Rr_C}{R+r_C} \right]. \quad (10)$$

These models are employed in Section 3 to derive robust controllers for the buck and the buck-boost converters.

2.3 Delay model for the PWM actuator

The models presented above do not take into account the sampling effect of the modulation (Brown & Middlebrook, 1981; Erickson & Maksimovic, 1999) (see Figure 4).

Usually, the sampling effect is not considered, and only the linear gain of the modulator is taken into account. In a voltage-mode modulator, the duty-cycle input is usually constrained between zero and the amplitude of the sawtooth signal V_M , and therefore the linear gain of this modulator is $1/V_M$ (Erickson & Maksimovic, 1999). For simplicity the amplitude V_M can be considered equal to one, such that the linear model shown previously is valid for a duty-cycle input $d \in [0, 1]$.

However, the sampling effect can be taken into account in order to limit the control-loop bandwidth in the automatic control synthesis algorithms. Such an effect can be incorporated to the power stage model as a sampling at the switching frequency $1/T_s$ and a zero-order hold block, assuming that the switch is fired once every switching cycle T_s (Maksimovic, 2000). The equivalent transfer function for this sampling model is then:

$$G_{ZOH}(s) = \frac{1 - e^{-sT_s}}{sT_s} \quad (11)$$

The exponential factor e^{-sT_s} can be approximated by a Padé function:

$$e^{-sT_s} \approx \frac{\sum_{k=0}^n -1^k c_k T_s s^k}{\sum_{k=0}^n c_k T_s s^k}, \quad c_k = \frac{(2n-k)!n!}{2n!k!(n-k)!}, \quad k = 0, 1, \dots, n. \quad (12)$$

Taking the first order approximation $n = 1$ we obtain

$$e^{-sT_s} \approx \frac{1 - (T_s/2)s}{1 + (T_s/2)s} \quad (13)$$

The equivalent hold transfer function with the Padé approximation writes

$$G_{ZOH}(s) = \frac{1}{1 + s\frac{T_s}{2}} \quad (14)$$

which is a strictly proper transfer function whose representation in state-space form could be:

$$\begin{cases} \dot{\tilde{x}}_p(t) = -(2/T_s)\tilde{x}_p(t) + (2/T_s)\tilde{d}(t) \\ \tilde{d}_2(t) = \tilde{x}_p(t) \end{cases} \quad (15)$$

where $\tilde{x}_p(t)$ is the state variable of the $G_{ZOH}(s)$, $\tilde{d}(t)$ is its input and $\tilde{d}_2(t)$ is its output.

2.4 Modeling of uncertainty

As stated in (Gahinet et al., 1995), the notion of system uncertainty is of major importance in the field of robust control theory. First of all, one of the key features of feedback is that it reduces the effects of uncertainty. However, when designing a control system, the model used to represent the behavior of the plant is often approximated. The difference between the approximated model and the true model is called model uncertainty. Also the changes due to operating conditions, aging effects, etc... are sources of uncertainty.

The two main approaches shown in (Gahinet et al., 1995) when dealing with system uncertainties and LMI control are:

- Uncertain state-space models, relevant for systems described by dynamical equations with uncertain and/or time-varying coefficients.
- Linear-fractional representation (LFR) of uncertainty, in which the uncertain system is described as an interconnection of known LTI systems.

While LFR models have had a main role in modern robust control synthesis methods such as in μ -synthesis (Zhou et al., 1996), state-space models have been used in convex optimization approaches (Boyd et al., 1994). Since this chapter presents approaches that do not employ the concept of structured singular value on which the μ -synthesis method is based, the following subsection is focused on uncertain state-space models.

If some of the physical parameters are approximated or unknown, or if there exists nonlinear or non-modeled dynamic effects, then the system can be described by an uncertain state-space model:

$$\begin{cases} \dot{x} = Ax + Bu \\ y = Cx + Du \end{cases} \quad (16)$$

where the state-space matrices A, B, C, D depend on uncertain and/or time-varying parameters or vary in some bounded sets of the space of matrices. One of the state-space representations of relevance in LMI control problems is the class of polytopic models:

Definition 2.1. A polytopic system is a linear time-varying system

$$\begin{cases} \dot{x} = A(t)x + B(t)u \\ y = C(t)x + D(t)u \end{cases} \quad (17)$$

in which the matrix $G(t) = \begin{bmatrix} A(t) & B(t) \\ C(t) & D(t) \end{bmatrix}$ varies within a fixed polytope of matrices

$$G(t) \in \text{Co}\{G_1, \dots, G_N\} := \left\{ \sum_{j=1}^N \delta_j G_j : \delta_j \geq 0, \sum_{j=1}^N \delta_j = 1 \right\} \quad (18)$$

where G_1, \dots, G_N are the vertices of the polytope.

In other words, $G(t)$ is a convex combination of the matrices G_1, \dots, G_N . Polytopics models are also called *linear differential inclusions* LDI in (Boyd et al., 1994).

2.4.1 Example: Buck converter polytopic model

Consider the buck converter model introduced in subsection 2.1, with $\tilde{w}(t) = 0$. For simplicity, the stray resistances are disregarded. If we take R and V_g as uncertain parameters of the converter, the uncertain system is described as follows

$$\begin{cases} \frac{d\tilde{x}(t)}{dt} = \left(\sum_{j=1}^N A_j \delta_j \right) \tilde{x}(t) + \left(\sum_{j=1}^N B_{uj} \delta_j \right) \tilde{d}(t) \\ \tilde{y}(t) = C_y \tilde{x}(t) + E_{yw} \tilde{w}(t) \end{cases} \quad (19)$$

with $\delta_j \geq 0$, $\sum_{j=1}^N \delta_j = 1$. The uncertain matrices A_j and B_{uj} are

$$A_j = \begin{bmatrix} 0 & -\frac{1}{L} \\ \frac{1}{C} & -\frac{1}{R_j C} \end{bmatrix}, \quad B_{uj} = \begin{bmatrix} \frac{V_{g_j}}{L} \\ 0 \end{bmatrix}, \quad (20)$$

where $R_j = \{R_{min} \ R_{max} \ R_{min} \ R_{max}\}$, and $V_{g_j} = \{V_{g_{min}} \ V_{g_{min}} \ V_{g_{max}} \ V_{g_{max}}\}$, which represents a uncertain polytope of four vertices (2 power the number of uncertain parameters, that are R_j and V_{g_j} in this example).

3. Robust control of dc-dc converters

Consider a general LTI model with states $x(t)$, controlled outputs $y(t)$ and performance outputs $z(t)$:

$$\Sigma : \begin{cases} \dot{x}(t) = Ax(t) + B_w w(t) + B_u u(t) \\ y(t) = C_y x(t) + E_{yw} w(t) + E_{yu} u(t) \\ z(t) = C_z x(t) + E_{zw} w(t) + E_{zu} u(t) \end{cases} \quad (21)$$

It is possible to assume that some elements involved in the system matrices are uncertain or time-varying. For the sake of simplicity, the performance and measurable outputs are discarded, hence these uncertain elements are concentrated in matrices A , B_w and B_u and they are grouped in a vector p . Thus, matrices A , B_w and B_u depend on such uncertainty vector, and we can express (21) as function of these parameters:

$$\dot{x}(t) = A(p)x(t) + B_w(p)w(t) + B_u(p)u(t). \quad (22)$$

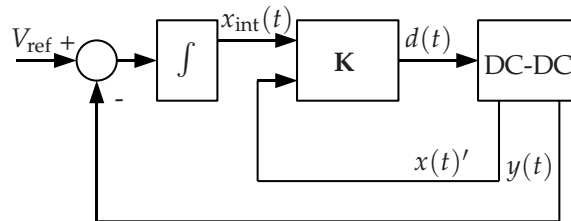

Fig. 5. Block diagram of a state-feedback system with controller \mathbf{K} and error integration.

This state-space representation has been previously used to derive robust control synthesis methods for dc-dc converters, which generally result in a state-feedback law that stabilizes the system for a certain range of uncertainty: parameter-dependent approaches for the linear dynamics of the converters are presented in (Montagner et al., 2005) and (Torres-Pinzon & Leyva, 2009) while (Hu, 2011) introduces a representation of the nonlinear dynamics. Consistent experimental results with tight performances are presented in (Olalla et al., 2009a; 2010a; 2011). The small-signal stabilization of nonlinear dc-dc converters is considered in (Olalla et al., 2009a; 2010a), where the converter is ensured to be stable in a range of operating points, but its trajectory between those points is not ensured to be stable due to the disregard of the nonlinear dynamics. These nonlinearities are taken into account in (Olalla et al., 2011) where also a less conservative polytopic uncertainty model is introduced. The state-feedback formulation of the control problem is of interest since (i) it may deliver better performance than some output-feedback approaches, (ii) it can be posed as a convex optimization problem with no conservatism or iterations and (iii) it is very simple to implement. However, the main disadvantage of state-feedback is that the full state vector must be available for measure, which is not always true. Therefore, it may require additional components and sensors to obtain the state or to implement estimators of the inaccessible states. Robust output-feedback approaches are then an alternative to derive robust controllers with known performances.

Robust control via output-feedback has been the subject of extensive research in the field of automatic control (de Oliveira & Geromel, 1997; Garcia et al., 2004; Peaucelle & Arzelier, 2001a;b; Scherer et al., 1997; Skogestad & Postlethwaite, 1996), but it has been hardly employed in dc-dc converters (Rodriguez et al., 1999). Power electronics engineers tend to use current-mode approaches (Erickson & Maksimovic, 1999) that employ an inner current loop before applying the output-feedback loop and, in that way, ease the control of the dc-dc converter. However, current-mode approaches require current sensing, as state-feedback control, and they suffer from noise, since in some cases, as in peak-current control, the current waveform must be sensed accurately. Therefore, a plain output-feedback approach can be of interest in certain cases in which a simple control is required and the sensing of all the states of the converter is not possible.

3.1 State-feedback control

The most simple control problem in terms of an LMI formulation is the one in which all the system states are measurable. The state-feedback problem considers the stabilization of (22) with a simple controller $u = \mathbf{K}x$, where $\mathbf{K} \in \mathbb{R}^{m \times n}$, as follows

$$\dot{x}(t) = (A(p) + B_u(p)\mathbf{K})x(t) + B_w(p)w(t). \quad (23)$$

Since the state-feedback approach does not allow to eliminate steady-state error, an additional

integral state can be introduced for the regulated output of the system, as shown in Figure 5. Once the augmented system has been rewritten in the form of (23), the following result, adapted from (Bernussou et al., 1989), points out a synthesis method to obtain a state-feedback controller that stabilizes quadratically the closed-loop system.

Theorem 3.1. *The system (23) is stabilizable by state-feedback $u = \mathbf{K}x$ if and only if there exist a symmetric matrix $\mathbf{W} \in \mathbb{R}^{n \times n}$ and a matrix $\mathbf{Y} \in \mathbb{R}^{m \times n}$ such that*

$$\begin{cases} \mathbf{W} > \mathbf{0} \\ \mathbf{A}\mathbf{W} + \mathbf{W}\mathbf{A}' + \mathbf{B}_u\mathbf{Y} + \mathbf{Y}'\mathbf{B}_u' < \mathbf{0} \end{cases} \quad (24)$$

then, the state-feedback is given by $\mathbf{K} = \mathbf{Y}\mathbf{W}^{-1}$.

Proof. *The proof uses a quadratic Lyapunov function $V(x) = x'\mathbf{P}x$, $\mathbf{P} = \mathbf{P}' > 0$, whose time-derivative along the trajectories of the closed-loop system $\dot{x} = (\mathbf{A} + \mathbf{B}_u)\mathbf{K}x$ must be definite negative (Boyd et al., 1994). It follows that the following condition*

$$\mathbf{A}'\mathbf{P} + \mathbf{P}\mathbf{A} + \mathbf{K}'\mathbf{B}_u'\mathbf{P} + \mathbf{P}\mathbf{B}_u\mathbf{K} < \mathbf{0} \quad (25)$$

has to be satisfied. Finally, considering the left and right-hand multiplication of the previous condition by $\mathbf{W} = \mathbf{P}^{-1}$, and the substitution of $\mathbf{K}\mathbf{W} = \mathbf{Y}$, LMI condition (24) follows.

A single Lyapunov function can be used to guarantee the stability of an uncertain system. The following theorem yields the state-feedback condition in the case of a polytopic representation.

Theorem 3.2. *The uncertain system defined by a convex polytope $\text{Co}\{G_1, \dots, G_N\}$ is quadratically stabilizable by state-feedback $u = \mathbf{K}x$ if and only if there exist a symmetric positive definite matrix \mathbf{W} and a matrix \mathbf{Y} such that*

$$\mathbf{A}_j\mathbf{W} + \mathbf{W}\mathbf{A}_j' + \mathbf{B}_{uj}\mathbf{Y} + \mathbf{Y}'\mathbf{B}_{uj}' < \mathbf{0} \quad \forall j = 1, \dots, N, \quad (26)$$

then $\mathbf{K} = \mathbf{Y}\mathbf{W}^{-1}$ is a state-feedback matrix.

The proof of this theorem is given in (Bernussou et al., 1989). It is worth to point out that there exist more recent works which have been concerned with the stability of polytopic uncertain systems considering in particular multiple Lyapunov functions instead of a single one (Apkarian et al., 2001; Bernussou & Oustaloup, 2002; Peaucelle & Arzelier, 2001c), in order to reduce the conservatism of the quadratic approach.

Example 1. *Buck-Boost Converter*

In this example, an uncertain polytopic model of the buck-boost converter is presented and a robust state-feedback controller is derived.

Consider the buck-boost converter model introduced in Section 2.2. Since for state-feedback control, the capacitor voltage is considered measurable, the stray resistance r_C is neglected. Also the stray resistances of the inductor and the semiconductor devices are disregarded. In order to obtain zero steady-state error between the voltage reference V_{ref} and the output voltage $v_o(t)$, the model is augmented with an additional state variable $x_{int}(t)$, which stands for the integral of the output voltage error, i.e. $x_{int}(t) = -\int (V_{ref} - v_o(t))dt$. The state vector of the new model is then written as

$$x(t) = \begin{bmatrix} i_L(t) \\ v_o(t) \\ x_{\text{int}}(t) \end{bmatrix}. \text{ Considering}$$

$$AX + B_w W + \begin{bmatrix} 0 \\ 1 \\ 0 \end{bmatrix} V_{\text{ref}} = 0, \quad (27)$$

the linear dynamics of the buck-boost converter are then written as:

$$\dot{\tilde{x}}(t) = A\tilde{x}(t) + B_w \tilde{w}(t) + B_u \tilde{u}(t) \quad (28)$$

$$A = \begin{bmatrix} 0 & \frac{D'}{L} & 0 \\ -\frac{D'}{C} & -\frac{1}{RC} & 0 \\ 0 & 1 & 0 \end{bmatrix}, B_w = \begin{bmatrix} \frac{D}{L} & 0 \\ 0 & -\frac{1}{C} \\ 0 & 0 \end{bmatrix}, B_u = \begin{bmatrix} \frac{V_g}{D'L} \\ \frac{D'L}{D'^2 RC} \\ 0 \end{bmatrix}. \quad (29)$$

Uncertainty:

Polytopic uncertainty (19) is introduced in the model of the converter to cope with the variations of D and R . The parameters of this example take the values shown in Table 1. Note that the transient performance requirements are only fulfilled when the trajectory starts from an equilibrium point. Consequently, the variations of D and R must be slow enough to allow the system states to return to the equilibrium.

Parameter	Value
$R \in$	$[10, 50] \Omega$
V_g	12 V
D	$[0, 0.7]$
C	200 μ F
L	100 μ H
T_s	5 μ s

Table 1. Buck-boost: converter parameters

As in (Olalla et al., 2009a), additional variables are introduced, in order to remove the non affine dependence of the system matrices on the uncertain terms. The uncertainty parameter vector is defined as $p = [R \ D' \ \delta_1 \ \delta_2]$, where:

$$\begin{aligned} R &\in [R_{\min}, R_{\max}], \\ D' &\in [D'_{\min}, D'_{\max}], \\ \delta_1 &\in [1/D'_{\max}, 1/D'_{\min}], \\ \delta_2 &\in [D_{\min}/D'_{\max}{}^2, D_{\max}/D'_{\min}{}^2]. \end{aligned} \quad (30)$$

Note that the uncertain model is inside a polytopic domain formed by $N = 2^4$ vertices. Also note that the multiplication between δ_2 and $1/R$ in the second row of B_u does not imply a new variable because both functions are strictly decreasing.

Sampling effect:

In this example the sampling effect has not been included in the converter, as the state variables of the modulator model can not be measured.

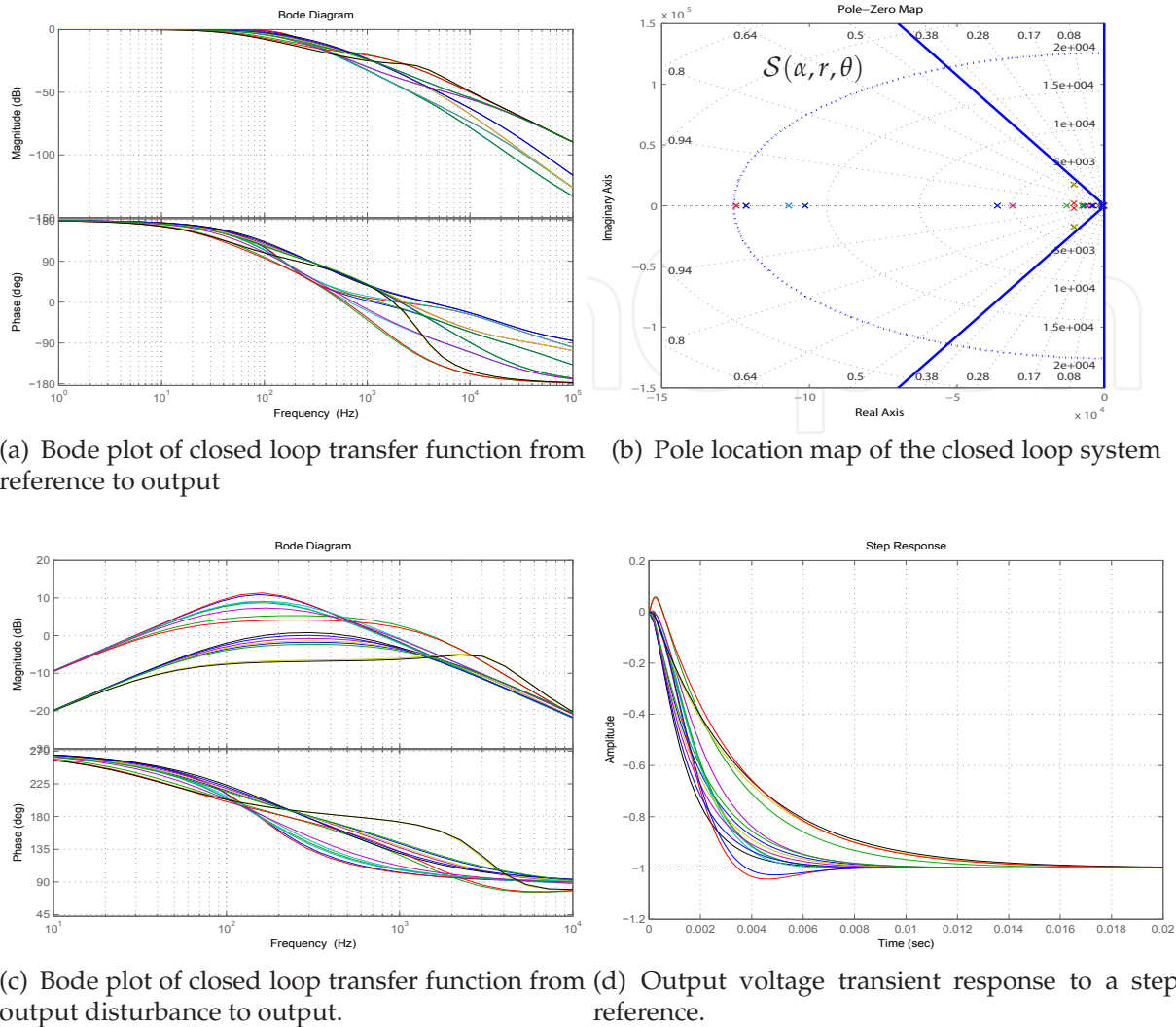

Fig. 6. Simulation results of Example 1, with controller \mathbf{K}_1 , for the sixteen vertices of the uncertainty set.

Performance Specifications:

Following the synthesis method shown in (Olalla et al., 2010a), the objective function to be minimized is the H_∞ norm of the transfer function between the output disturbance $\tilde{i}_{load}(t)$ and the output voltage $\tilde{v}_o(t)$.

In order to assure robust transient performances, the closed loop poles are constrained in an LMI region $\mathcal{S}(\alpha, r, \theta)$, where the desired minimum damping ratio is set to $\theta = \frac{1}{\sqrt{2}}$, the required maximum damped frequency is $r = \frac{1}{10} \frac{2\pi}{T_s}$, and the minimum decay rate, for a settling time lower than 20 ms, is set to $\alpha = 200$.

Results:

The robust control synthesis algorithm yields a controller \mathbf{K}_1 :

$$\mathbf{K}_1 = [-0.31 \quad -0.25 \quad 194.70] \tag{31}$$

that ensures an H_∞ norm from output disturbance to output voltage of 3.80 (11.6 dB). Figure 6 shows

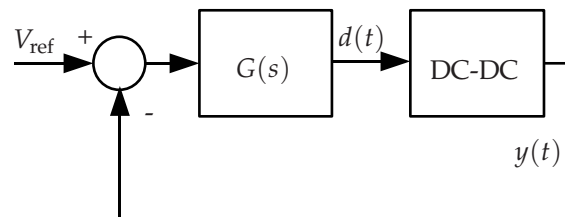

Fig. 7. Block diagram of an output-feedback system with controller $G(s)$.

the simulation results of the controller over the sixteen vertices of the set of matrices. Since the nonlinear terms are disregarded, the robust stability and performance of the converter is guaranteed while the converter remains in the considered operating points, assuming that the change between these operation points is sufficiently slow. In order to account for the neglected dynamics, see (Hu, 2011; Olalla et al., 2009b; 2011).

3.2 Output-feedback control

Figure 7 shows the general diagram of an output-feedback control system. Depending on the structure of the controller $G(s)$, two main approaches can be differentiated for the synthesis of output-feedback controllers: static and dynamic controllers.

Given the system Σ as described in (21), for the buck and the buck-boost converter $E_{yu} = 0$ can be considered. Then, in the case of a dynamic controller of order k with the following structure

$$\Sigma_K : \begin{cases} \dot{x}_c = \mathbf{A}_c x_c + \mathbf{B}_c y \\ u = \mathbf{C}_c x_c + \mathbf{D}_c y \end{cases}, \quad (32)$$

the closed loop system has the form

$$T_{\Sigma_K} : \begin{cases} \dot{x}_{cl} = \mathbf{A} x_{cl} + \mathbf{B} w \\ z = \mathbf{C} x_{cl} + \mathbf{D} w \end{cases} \quad (33)$$

where

$$\left[\begin{array}{c|c} \mathbf{A} & \mathbf{B} \\ \hline \mathbf{C} & \mathbf{D} \end{array} \right] = \left[\begin{array}{cc|c} A + B_u \mathbf{D}_c \mathbf{C}_y & B_u \mathbf{C}_c & B_w + B_u \mathbf{D}_c E_{yw} \\ \mathbf{B}_c \mathbf{C}_y & \mathbf{A}_c & \mathbf{B}_c E_{yw} \\ \hline C_z + E_{zu} \mathbf{D}_c \mathbf{C}_y & E_{zu} \mathbf{C}_c & E_{zw} + E_{zu} \mathbf{D}_c D_{yw} \end{array} \right] \quad (34)$$

In the case of a static controller, $\mathbf{K} \in \mathbb{R}^{m \times q}$

$$u = \mathbf{K}y = \mathbf{K}(C_y x + E_{yw} w) \quad (35)$$

and the closed loop system has the following structure

$$T_K : \begin{cases} \dot{x} = \mathbf{A} x + \mathbf{B} w \\ z = \mathbf{C} x + \mathbf{E} w \end{cases} \quad (36)$$

where

$$\left[\begin{array}{c|c} \mathbf{A} & \mathbf{B} \\ \hline \mathbf{C} & \mathbf{E} \end{array} \right] = \left[\begin{array}{c|c} (A + B_u \mathbf{K} C_y) & (B_w + B_u \mathbf{K} E_{yw}) \\ \hline (C_z + E_{zu} \mathbf{K} C_y) & (E_{zw} + E_{zu} \mathbf{K} E_{yw}) \end{array} \right] \quad (37)$$

For both problems the Lyapunov inequality is written, in a generic form:

$$\begin{cases} \mathbf{P} > \mathbf{0} \\ \mathbf{A}'\mathbf{P} + \mathbf{P}\mathbf{A} < \mathbf{0} \end{cases} \quad (38)$$

which depends non-linearly on \mathbf{P} and the matrices of the controller (\mathbf{K} in the static case or $\mathbf{A}_c, \mathbf{B}_c, \mathbf{C}_c, \mathbf{D}_c$ in the dynamic case).

There exist several methods to linearize the output-feedback synthesis problem. For the dynamic output-feedback case, the results of reference (Scherer et al., 1997) are summarized. In the case of static output-feedback, the methods shown in (de Oliveira & Geromel, 1997) and (Peaucelle & Arzelier, 2001a) are employed.

3.2.1 Dynamic output-feedback

The dynamic output-feedback synthesis method shown in (Scherer et al., 1997) employs the following transfer function parametrization defined from the exogenous input $w = w_j R_j$ to the cost output $z_j = L_j z$ as follows:

$$T_j(s) = \frac{z_j(s)}{w_j(s)} := \left[\frac{\mathbf{A} | \mathbf{B}_j}{\mathbf{C}_j | \mathbf{D}_j} \right] = \left[\frac{\mathbf{A} | \mathbf{B}R_j}{L_j \mathbf{C} | L_j \mathbf{D}R_j} \right] = \left[\frac{A + B_u \mathbf{D}_c C_y \quad B_u \mathbf{C}_c \quad B_j + B_u \mathbf{D}_c F_j}{\mathbf{B}_c C_y \quad \mathbf{A}_c \quad \mathbf{B}_c F_j}{C_j + E_j \mathbf{D}_c C_y \quad E_j \mathbf{C}_c \quad D_j + E_j \mathbf{D}_c F_j} \right] \quad (39)$$

where

$$B_j := B_w R_j, \quad C_j := L_j C_z, \quad D_j := L_j E_{zw} R_j, \quad E_j := L_j E_{zu}, \quad F_j := E_{yw} R_j. \quad (40)$$

To find a controller which stabilizes the closed-loop system, there must exist a quadratic Lyapunov function

$$V(x_{cl}) = x_{cl}' \mathbf{P} x_{cl}, \quad (41)$$

such that

$$\begin{cases} \mathbf{P} > \mathbf{0} \\ \mathbf{A}'\mathbf{P} + \mathbf{P}\mathbf{A} < \mathbf{0} \end{cases} \quad (42)$$

The LMI constraints are formulated for a transfer function $T_j(s) = L_j T(s) R_j$, in terms of the state-space matrices $\mathbf{A}, \mathbf{B}_j, \mathbf{C}_j, \mathbf{D}_j$. The goal is to synthesize an LTI controller Σ_K that:

- internally stabilizes the system
- meets certain specifications (H_2, H_∞ , pole placement,...) on a particular set of channels.

Generally, each transfer function T_j will satisfy each specification S_j , if there exists a Lyapunov matrix $\mathbf{P}_j > 0$ that satisfies some LMI constraints in \mathbf{P}_j . The control problem usually includes a number i of specifications. Therefore, the synthesis problem involves a set of matrix inequalities whose variables are:

- the controller matrices $\mathbf{A}_c, \mathbf{B}_c, \mathbf{C}_c, \mathbf{D}_c$.
- the i Lyapunov matrices $\mathbf{P}_1, \dots, \mathbf{P}_i$, one per specification.
- additional auxiliary variables to minimize, for example, the norm cost H_∞ .

Since this problem is nonlinear and hardly tractable numerically, the method shown in (Scherer et al., 1997) requires that all the specifications are satisfied with a single Lyapunov function, that is:

$$\mathbf{P}_1 = \dots = \mathbf{P}_i = \mathbf{P}. \quad (43)$$

This restriction involves conservatism in the design, but it leads to a numerically tractable LMI problem, it produces controllers of reasonable order and it exploits all degrees of freedom in \mathbf{P} (Scherer et al., 1997). Actually, if a single Lyapunov function \mathbf{P} is considered, the following change of variable linearizes the control problem and makes it solvable with LMIs.

Let n be the number of states of the plant, and let k be the order of the controller. Partition \mathbf{P} and \mathbf{P}^{-1} as

$$\mathbf{P} = \begin{bmatrix} \mathbf{Y} & \mathbf{N} \\ \mathbf{N}' & \star \end{bmatrix}, \quad \mathbf{P}^{-1} = \begin{bmatrix} \mathbf{X} & \mathbf{M} \\ \mathbf{M}' & \star \end{bmatrix} \quad (44)$$

where \mathbf{X} and \mathbf{Y} are $\in \mathbb{S}^n$, and \star is a symmetric positive definite matrix such that $\mathbf{P}\mathbf{P}^{-1} = \mathbf{1}$ holds.

From $\mathbf{P}\mathbf{P}^{-1} = \mathbf{1}$ we infer $\mathbf{P} \begin{pmatrix} \mathbf{X} \\ \mathbf{M}' \end{pmatrix} = \begin{pmatrix} \mathbf{1} \\ \mathbf{0} \end{pmatrix}$, which leads to

$$\mathbf{P}\Pi_1 = \Pi_2, \quad \Pi_1 = \begin{bmatrix} \mathbf{X} & \mathbf{1} \\ \mathbf{M}' & \mathbf{0} \end{bmatrix}, \quad \Pi_2 = \begin{bmatrix} \mathbf{1} & \mathbf{Y} \\ \mathbf{0} & \mathbf{N}' \end{bmatrix} \quad (45)$$

The change of variables is as follows

$$\begin{cases} \hat{\mathbf{A}} := \mathbf{N}\mathbf{A}_c\mathbf{M}' + \mathbf{N}\mathbf{B}_c\mathbf{C}_y\mathbf{X} + \mathbf{Y}\mathbf{B}_u\mathbf{C}_c\mathbf{M}' + \mathbf{Y}(\mathbf{A} + \mathbf{B}_u\mathbf{D}_c\mathbf{C}_y)\mathbf{X} \\ \hat{\mathbf{B}} := \mathbf{N}\mathbf{B}_c + \mathbf{Y}\mathbf{B}_u\mathbf{D}_c \\ \hat{\mathbf{C}} := \mathbf{C}_c\mathbf{M}' + \mathbf{D}_c\mathbf{C}_y\mathbf{X} \\ \hat{\mathbf{D}} := \mathbf{D}_c \end{cases} \quad (46)$$

where $\hat{\mathbf{A}}, \hat{\mathbf{B}}, \hat{\mathbf{C}}$ have dimensions $n \times n, n \times m, q \times n$ respectively. If M and N have full row rank, and $\hat{\mathbf{A}}, \hat{\mathbf{B}}, \hat{\mathbf{C}}, \hat{\mathbf{D}}, \mathbf{X}, \mathbf{Y}$ are given, the matrices $\mathbf{A}_c, \mathbf{B}_c, \mathbf{C}_c, \mathbf{D}_c$ can be computed. If M and N are square $n = k$ and invertible, then $\mathbf{A}_c, \mathbf{B}_c, \mathbf{C}_c, \mathbf{D}_c$ are unique.

The motivation for this change of variables lies in the following identities

$$\begin{aligned} \Pi_1' \mathbf{P} \mathbf{A} \Pi_1 &= \Pi_2' \mathbf{A} \Pi_1 = \begin{bmatrix} \mathbf{A}\mathbf{X} + \mathbf{B}\hat{\mathbf{C}} & \mathbf{A} + \mathbf{B}_u\mathbf{D}_c\mathbf{C}_y \\ \hat{\mathbf{A}} & \mathbf{Y}\mathbf{A} + \hat{\mathbf{B}}\mathbf{C}_y \end{bmatrix} \\ \Pi_1' \mathbf{P} \mathbf{B}_j &= \Pi_2' \mathbf{B}_j = \begin{bmatrix} \mathbf{B}_j + \mathbf{B}_u\mathbf{D}_c\mathbf{F}_j \\ \mathbf{Y}\mathbf{B}_j + \hat{\mathbf{B}}\mathbf{F}_j \end{bmatrix} \\ \mathbf{C}_j \Pi_1 &= [\mathbf{C}_j\mathbf{X} + \mathbf{E}_j\hat{\mathbf{C}} \quad \mathbf{C}_j + \mathbf{E}_j\hat{\mathbf{D}}\mathbf{C}_y] \\ \Pi_1' \mathbf{P} \Pi_1 &= \Pi_1' \Pi_2 = \begin{bmatrix} \mathbf{X} & \mathbf{1} \\ \mathbf{1} & \mathbf{Y} \end{bmatrix} \end{aligned} \quad (47)$$

which can be used in a congruence transformation to derive the LMI constraints. A detailed proof is given in (Scherer et al., 1997).

Once the variables $\hat{\mathbf{A}}, \hat{\mathbf{B}}, \hat{\mathbf{C}}, \hat{\mathbf{D}}, \mathbf{X}, \mathbf{Y}$ have been found, let us recover the original system by following this procedure. First we need to construct M, N and \mathbf{P} that satisfy (45). M and N should be chosen such that $\mathbf{N}\mathbf{M}' = \mathbf{1} - \mathbf{Y}\mathbf{X}$. With the following LMI:

$$\begin{bmatrix} \mathbf{X} & \mathbf{1} \\ \mathbf{1} & \mathbf{Y} \end{bmatrix} > \mathbf{0} \quad (48)$$

we assure $\mathbf{Y} > \mathbf{0}$ and $\mathbf{X} - \mathbf{Y}^{-1} > \mathbf{0}$ such that $\mathbf{1} - \mathbf{Y}\mathbf{X}$ is nonsingular. Hence, M and N can always be found. After that, Π_1 and Π_2 are also nonsingular, and $\mathbf{P} = \Pi_2\Pi_1^{-1}$ can be found.

Then \mathbf{D}_c , \mathbf{C}_c , \mathbf{B}_c and \mathbf{A}_c can be solved, in this order:

$$\begin{cases} \mathbf{D}_c := \hat{\mathbf{D}} \\ \mathbf{C}_c := (\hat{\mathbf{C}} - \mathbf{D}_c \mathbf{C}_y \mathbf{X}) \mathbf{M}'^{-1} \\ \mathbf{B}_c := \mathbf{N}^{-1} (\hat{\mathbf{B}} - \mathbf{Y} \mathbf{B}_u \mathbf{D}_c) \\ \mathbf{A}_c := \mathbf{N}^{-1} (\hat{\mathbf{A}} - \mathbf{N} \mathbf{B}_c \mathbf{C}_y \mathbf{X} - \mathbf{Y} \mathbf{B}_u \mathbf{C}_c \mathbf{M}' - \mathbf{Y} (\mathbf{A} + \mathbf{B}_u \mathbf{D}_c \mathbf{C}_y) \mathbf{X}) \mathbf{M}'^{-1} \end{cases} \quad (49)$$

For a list of LMI constraints which respond to several specifications with this change of variables, it is recommended to read (Scherer et al., 1997).

Example 2. Buck Converter

In this example, the synthesis of an output-feedback controller for a buck converter is carried out. The objective of the synthesis algorithm is, again, to minimize the H_∞ norm of the output disturbance to output voltage transfer function.

In this case the stray resistances of the converter are taken into account, since only the output signals are used. This design considers a unique output signal $v_o(t)$ to set-up a voltage-regulation operation.

Sampling effect:

The sampling effect could be included in the converter model, in order to prevent the optimization algorithm to yield unrealistic results due to the switching action. However, in this case, a weighting function on the complementary sensitivity response can be used for this purpose.

Uncertainty:

Polytopic uncertainty (19) can be introduced in the model of the converter to cope with the variations of the uncertain parameters, as the load or the input voltage. However, in the case of output-feedback the polytopic representation of uncertainty introduces nonlinear relationship between the variables of the inequalities. This problem is treated in (Courties, 1997; 1999) where a cross-decomposition algorithm is described to obtain a local optimum controller giving an initial feasible solution. The solution proposed in this example exploits the weighting transfer functions to obtain the expected sensitivity and complementary sensitivity responses. The parameters of this example take the values shown in Table 2. The synthesis algorithm closely follows the linearizing change of variables of (Scherer et al.,

Parameter	Value
R	1000 Ω
V_g	55 V
C	1000 μ F
L	100 μ H
r_{eq}	150 m Ω
r_C	30 m Ω
T_s	5 μ s

Table 2. Buck: converter parameters

1997) and the methodology explained in chapters 5 and 6 of (Gahinet et al., 1995):

1. First, the design specifications are expressed in terms of loop shapes and their corresponding shaping filters.
2. Then, the original plant is augmented with such filters to obtain a weighted plant.
3. Finally, the augmented plant is used in the optimization algorithm to derive a controller that meets certain LMIs.

The algorithm yields a controller of the same order as the augmented plant, that is, the order of the original plant plus the order of the shaping filters.

Performance Specifications:

The objective of the design procedure is to minimize the H_∞ norm of the disturbance to output transfer function. For such objective, a weighting function $W_1(s)$ for the error signal (i.e. for the sensitivity function) and a weighting function $W_2(s)$ for the output signal (i.e. for the complementary sensitivity function) are considered. Both weighting functions are depicted in Figure 8(b). In order to obtain small steady-state error, $W_1(s)$ is very large at low frequencies.

Other performance requirements could have been included (pole placement, H_2 , ...) in the optimization problem, but they have not been used to maintain all the degrees of freedom in the research of the minimum H_∞ norm.

Results:

The minimization algorithm yields the following controller transfer function (1 input, 1 output):

$$\mathbf{K}_2(s) = -3.00 \frac{(s + z_1)(s + z_2)(s + z_{3,4})(s + z_{5,6})}{(s + p_1)(s + p_2)(s + p_{3,4})(s + p_{5,6})} \quad (50)$$

where

$$\begin{array}{l|l} p_1 = -1.05 \cdot 10^{-2} & z_1 = -4.39 \cdot 10^2 + j6.04 \cdot 10^2 \\ p_2 = -4.90 \cdot 10^3 & z_2 = -4.39 \cdot 10^2 - j6.04 \cdot 10^2 \\ p_3 = -6.66 \cdot 10^4 & z_3 = -1.89 \cdot 10^3 \\ p_4 = -1.36 \cdot 10^9 & z_4 = -3.50 \cdot 10^9 \end{array} \quad (51)$$

The maximum guaranteed gain peak from disturbance to output is $\gamma = 0.045$ (-26.93 dB). Figure 8 depicts the simulation results for the nominal frequency and time-domain response of the buck converter.

3.2.2 Static output-feedback

An alternative to the use of weighting functions and frequency dependent uncertainty models is to consider the static output-feedback case. Static output-feedback considers a gain \mathbf{K} to set up the feedback loop as $u = \mathbf{K}y$.

The survey on output-feedback design methods (de Oliveira & Geromel, 1997) differentiates between several approaches to solve the synthesis of a static output gain as follows:

1. Nonlinear programming methods. They work on the parametric space defined by \mathbf{K} and \mathbf{P} to find an optimal value of a cost variable, if any. The search is done by means of classical optimization methods as, for example, a gradient algorithm, primal or dual Levine-Athans' method, etc. The solution of the algorithm, which converges to a local optimum, strongly depends on an initial stabilizing gain, which must be found beforehand.
2. Parametric optimization methods. These methods optimize the objective function for the parametric space defined by \mathbf{P} , for some matrix \mathbf{K} . The determination of the controller, if it exists, is decomposed in independent steps. These methods can be easily implemented using LMI solvers.
3. Convex programming methods. They solve a sufficient version of the Lyapunov inequality (38) obtained by the addition of constraints which lead to a convex feasibility set.

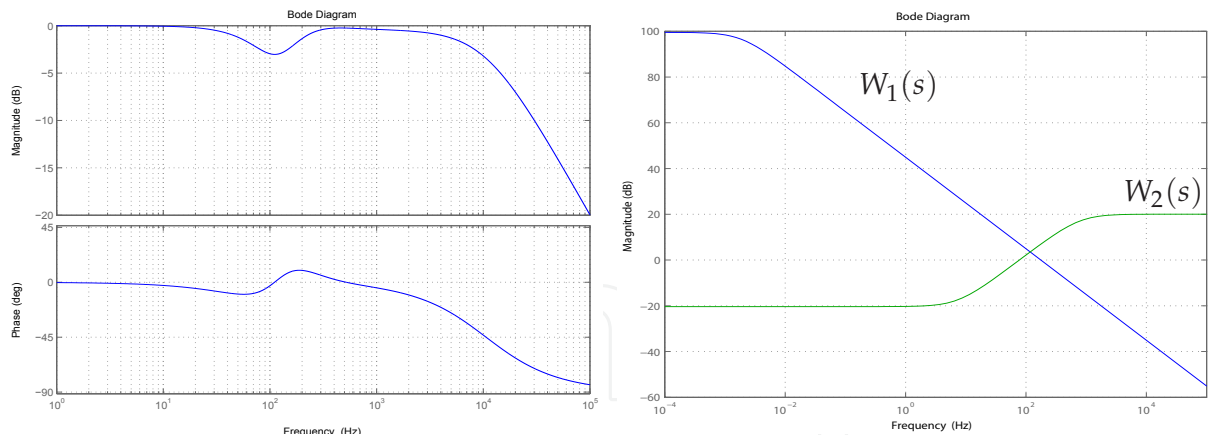

(a) Bode plot of closed loop transfer function from reference to output. (b) Weighting functions for dynamic output-feedback synthesis.

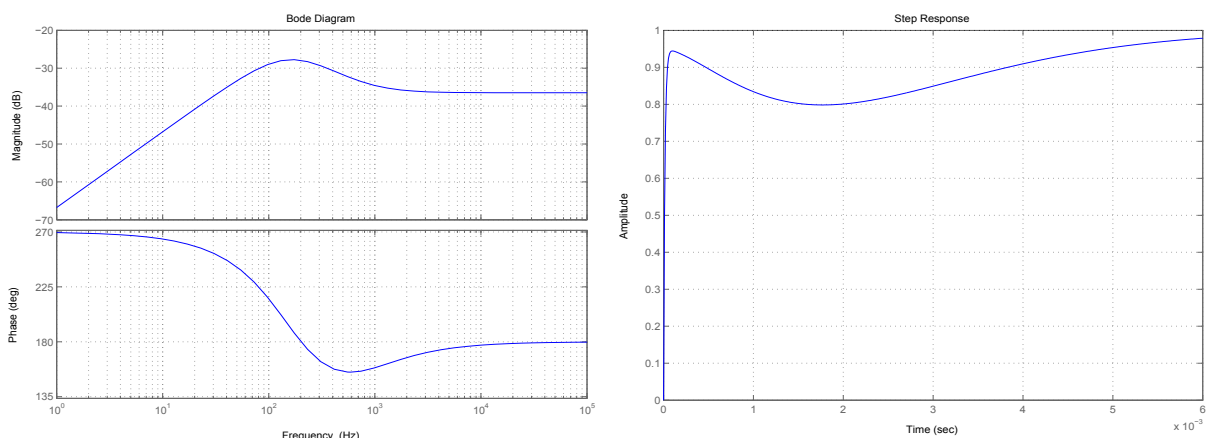

(c) Bode plot of closed loop transfer function from output disturbance to output. (d) Output voltage transient response to a step reference.

Fig. 8. Simulation results of Example 2 with controller $K_2(s)$.

The proposed parametrization is based on the elimination lemma (Boyd et al., 1994) and the introduction of additional variables to obtain an iterative algorithm. It has been extracted from (Peaucelle & Arzelier, 2001a).

Theorem 3.3. *The Lyapunov inequality (38) can be rewritten as follows*

$$\begin{cases} \mathbf{P} > \mathbf{0} \\ \begin{bmatrix} A'\mathbf{P} + \mathbf{P}A & \mathbf{P}B_2 \\ B_2'\mathbf{P} & \mathbf{0} \end{bmatrix} + \begin{bmatrix} \mathbf{K}'_s \\ \mathbf{1} \end{bmatrix} [\mathbf{R}C_y - \mathbf{F}] + \begin{bmatrix} C_y'\mathbf{R}' \\ -\mathbf{F}' \end{bmatrix} [\mathbf{K}_s - \mathbf{1}] < \mathbf{0} \end{cases} \quad (52)$$

where \mathbf{K}_s is a state-feedback gain that stabilizes the system. At the optimum point, which depends on the objective function, the output-feedback controller is given by $\mathbf{K} = \mathbf{F}^{-1}\mathbf{R}$.

Proof. The equation (38) can be written as the following product of matrices:

$$\begin{bmatrix} \mathbf{1} & C_y'\mathbf{K}' \end{bmatrix} \begin{bmatrix} A'\mathbf{P} + \mathbf{P}A & \mathbf{P}B_2 \\ B_2'\mathbf{P} & \mathbf{0} \end{bmatrix} \begin{bmatrix} \mathbf{1} \\ \mathbf{K}C_y \end{bmatrix} < \mathbf{0} \quad (53)$$

Applying the elimination lemma with

$$Q = \begin{bmatrix} A'P + PA & PB_2 \\ B_2'P & \mathbf{0} \end{bmatrix} N = KC_y \quad (54)$$

we obtain

$$\begin{bmatrix} A'P + PA & PB_2 \\ B_2'P & \mathbf{0} \end{bmatrix} + \begin{bmatrix} C_y'K' \\ \mathbf{1} \end{bmatrix} G' + G [KC_y - \mathbf{1}] < \mathbf{0} \quad (55)$$

With $G = \begin{bmatrix} F_s \\ -F \end{bmatrix}$, the previous inequality is written as

$$\begin{bmatrix} A'P + PA & PB_2 \\ B_2'P & \mathbf{0} \end{bmatrix} + \begin{bmatrix} C_y'K' \\ \mathbf{1} \end{bmatrix} [F_s' - F'] + \begin{bmatrix} F_s \\ -F \end{bmatrix} [KC_y - \mathbf{1}] < \mathbf{0} \quad (56)$$

With the following change of variables

$$K_s' = F_s F^{-1}, \quad R = FK, \quad (57)$$

it is verified that $K = F^{-1}R = F^{-1}FK$, and we obtain the result of (52).

This parametrization has been adapted to the minimization of the performance indexes H_2 and H_∞ (Peaucelle & Arzelier, 2001a;b).

With the new introduced variables we can split the optimization problem into two linear steps; in the first step, K_s is kept constant, and the problem is solved for P , R and F . Then, in the next step, R and F are kept constant and the problem is solved for P and K_s . With this iterative process, a stabilizing gain that satisfies a given cost function can be obtained.

A key point of this approach is however related to the initialization step, for which and admissible stabilizing state-feedback has to be selected. On the other hand, this algorithm presents the advantage that the Lyapunov matrix P is set as a free variable in both steps.

Algorithm 3.1.

1. Initialization. Step $k = 1$. Choose a stabilizing state-feedback gain.
2. Iterative step k first part. Solve the LMI (52) in which K_s is constant.
3. Iterative step k second part. Solve the LMI (52) in which F and R are constant.
4. Final step. If the objective function satisfies the requirements, then stop $K = F^{-1}R$, else $k = k + 1$ and return to step 2.

Example 3. Buck Converter

In this example, the previous output-feedback parametrization is employed to derive a static controller for a buck converter, whose model was introduced in Section 2.2. The stray resistances of the model are taken into account in this case. Also, note that the augmented model contains an integrator of the error between the output and the reference.

Uncertainty:

The output-feedback parametrization allows to consider the polytopic uncertainty model shown in Section 2.4. In this case, the uncertain model is formed by $N = 2^2$ vertices. The values of the converter are shown in Table 3.

Parameter	Value
R	$\in [10, 1000] \Omega$
V_g	$\in [33, 55] V$
C	$1000 \mu F$
L	$100 \mu H$
r_{eq}	$150 m\Omega$
r_c	$50 m\Omega$
T_s	$5 \mu s$

Table 3. Buck: converter parameters

Sampling effect:

Since only the output signal is used, the sampling effect is included in the converter model in order to obtain an accurate model up to half the switching frequency. This addition also prevents the optimization algorithms to yield unrealistic results due to the switching action.

Performance Specifications:

Following the synthesis method shown in (Olalla et al., 2010a), the objective function to be minimized is the H_∞ norm of the transfer function between the output disturbance $\tilde{i}_{load}(t)$ and the output voltage. As in the state-feedback case, the closed loop poles are constrained in an LMI region $\mathcal{S}(\alpha, r, \theta)$, in order to assure robust transient performances. Again, the desired minimum damping ratio is set to $\theta = \frac{1}{\sqrt{2}}$, the required maximum damped frequency is $r = \frac{1}{10} \frac{2\pi}{T_s}$, and the minimum decay rate, for a settling time lower than 40 ms, is set to $\alpha = 100$.

Results:

The robust control synthesis algorithm yields a controller \mathbf{K}_3 :

$$\mathbf{K}_3 = 4.472 \quad (58)$$

that assures an H_∞ norm from output disturbance to output voltage of 0.656 (-3.66 dB). The waveforms of a numerical simulation and corresponding Bode plots of the converter with controller \mathbf{K}_3 over the four vertices of the set of matrices are depicted in Figure 9. It can be observed that the static output-feedback controller does not achieve the performance of the dynamic output-feedback controller $\mathbf{K}_2(s)$.

3.2.3 Dynamic output-feedback with static parametrization

The parametrization method shown in the previous subsection for the static case can be adapted to the synthesis of a dynamic output-feedback controller. The following theorem can be found in (Martenson, 1985; Nett et al., 1989).

Theorem 3.4. The synthesis of a dynamic controller Σ_K for the system Σ (for simplicity, in absence of perturbations ($w = 0$)) can be expressed as the synthesis of a static controller for the augmented system Σ_{aug} :

$$\Sigma_{aug} : \begin{cases} \dot{x}_{aug} = \begin{bmatrix} A & \mathbf{0} \\ \mathbf{0} & \mathbf{0} \end{bmatrix} x_{aug} + \begin{bmatrix} \mathbf{0} & B \\ \mathbf{1} & \mathbf{0} \end{bmatrix} u_{aug} \\ y_{aug} = \begin{bmatrix} \mathbf{0} & \mathbf{1} \\ C & \mathbf{0} \end{bmatrix} x_{aug} + \begin{bmatrix} \mathbf{0} & \mathbf{0} \\ \mathbf{0} & D \end{bmatrix} u_{aug} \end{cases} \quad (59)$$

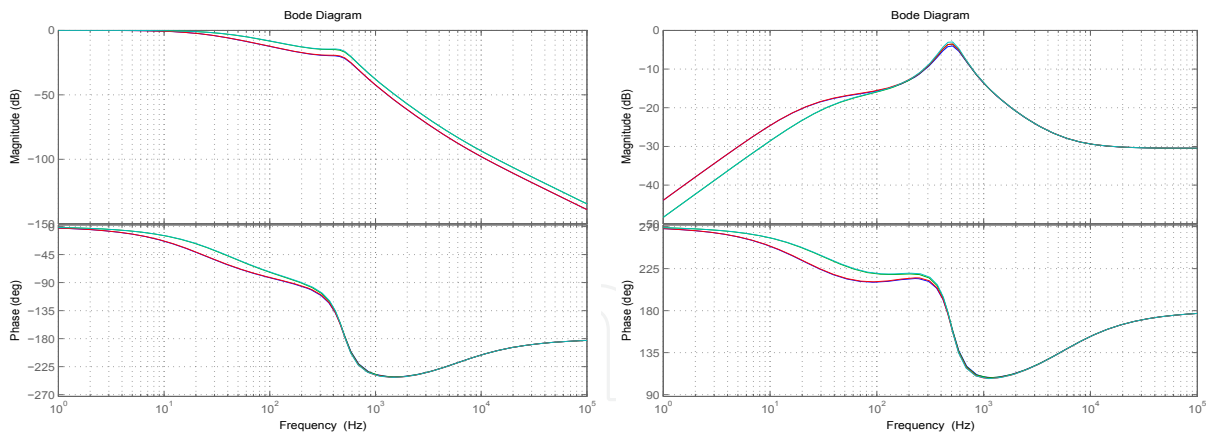

(a) Bode plot of closed loop transfer function from reference to output.

(b) Bode plot of closed loop transfer function from output disturbance to output.

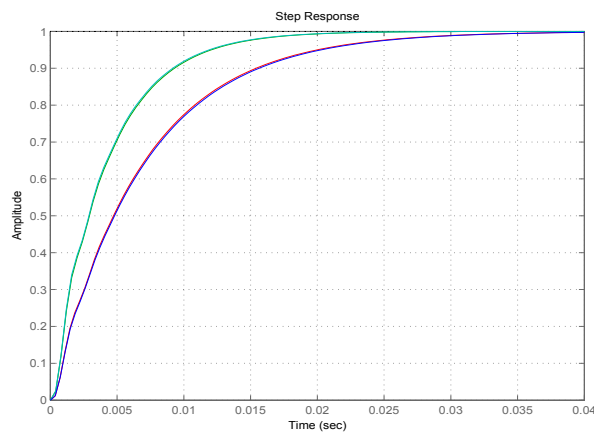

(c) Output voltage transient response to a step reference.

Fig. 9. Simulation results of Example 3 with controller K_3 .

where

$$x_{aug} = \begin{bmatrix} x \\ x_c \end{bmatrix} \quad u_{aug} = \begin{bmatrix} \dot{x}_c \\ u \end{bmatrix} \quad y_{aug} = \begin{bmatrix} x_c \\ y \end{bmatrix} \quad (60)$$

and

$$K = \begin{bmatrix} A_c & B_c \\ C_c & D_c \end{bmatrix} \quad (61)$$

Example 4. Buck Converter

A dynamic controller using the static output-feedback parametrization is derived in this subsection. As in the static case, the stray resistances and a pure integrator are considered. The system is augmented with an integrator and with the controller states to obtain a dynamic controller. For this case a simple first-order controller is considered.

$$K(s) = k \frac{(s + z)}{(s + p)} \quad (62)$$

Uncertainty:

As in the previous subsection, the synthesis considers a polytopic model. A new LMI is introduced for every vertex of the uncertain model. The polytopic model used in this subsection considers the same uncertain load R and input voltage V_g , as shown in Table 4.

Parameter	Value
R	$\in [10, 1000] \Omega$
V_g	$\in [33, 55] V$
C	$1000 \mu F$
L	$100 \mu H$
r_{eq}	$150 m\Omega$
r_c	$50 m\Omega$
T_s	$5 \mu s$

Table 4. Buck: converter parameters

Sampling effect:

Again, the sampling effect is included in the converter model in order to obtain an accurate model up to half the switching frequency.

Performance Specifications:

As in the previous case, the objective is to minimize the H_∞ norm of the transfer function between the disturbance and the output. Also, the closed loop poles are constrained in the same LMI region $S(\alpha, r, \theta)$, in order to assure robust transient performances.

The initialization step is constrained with the corresponding pole placement inequalities and its objective function tries to enforce the states of the dynamic controller, using a weight β on $\mathbf{R} = \mathbf{F}\mathbf{K}$.

$$\begin{aligned} & \max f(\beta\mathbf{R}) \text{ subject to} \\ & \mathbf{W} > \mathbf{0} \\ & \mathbf{W}\mathbf{A}' + \mathbf{A}\mathbf{W} + \mathbf{Y}'\mathbf{B}'_u + \mathbf{B}_u\mathbf{Y} < \mathbf{0} \end{aligned} \quad (63)$$

where for this case of one input and one state of the dynamic controller can be considered $\beta = \begin{bmatrix} \beta_1 & 0 \\ 0 & \beta_2 \end{bmatrix}$, $\beta_1 > \beta_2$. If an initial state-feedback is found then the iterative step minimizes the H_∞ norm γ .

Results:

For the present case the algorithm yields the following controller:

$$\mathbf{K}_4 = \left[\begin{array}{c|c} \mathbf{A}_c & \mathbf{B}_c \\ \hline \mathbf{C}_c & \mathbf{D}_c \end{array} \right] = \left[\begin{array}{c|c} -7475.4 & -97.9 \\ \hline 851.3 & 10.3 \end{array} \right] \quad (64)$$

Note that the integrator is not included in the previous expression. The Bode plot of the controller with the integrator is depicted in Figure 10(b).

The guaranteed H_∞ norm with the controller \mathbf{K}_4 achieves the value $\gamma = 0.571$. The simulation results are shown in Figure 10. It can be observed that the lag-lead compensation of the controller slightly changes the gain peak of the transfer function of interest, yielding slightly better output disturbance attenuation, but longer settling time with respect to the constant output feedback gain. Consequently, this method can be seen as an intermediate solution between dynamic and static output feedback,

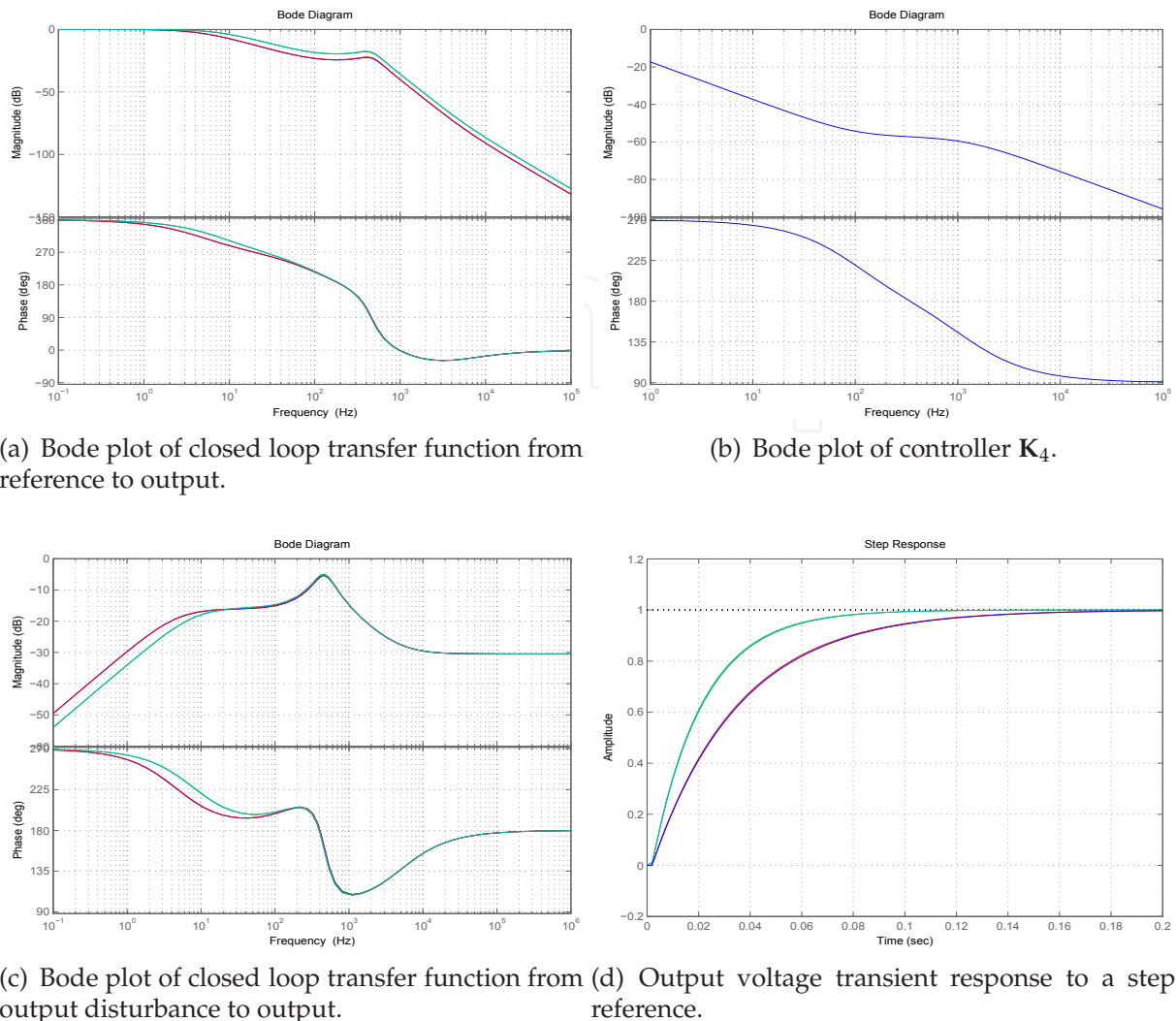

Fig. 10. Simulation results of Example 4 with controller K_4 .

with the main drawback that the solution of the iterative algorithm may depend on the chosen initial state-feedback gain.

4. Conclusions

In the chapter, it has been shown how a control formulation based on linear matrix inequalities can cope not only with academic optimization problems, but also with large real-life complex problems, since the numerical solution can be found by efficient computer algorithms.

The synthesis (or analysis) of the control system can be made by solving an optimization problem, using the concepts of Lyapunov stability and positive definiteness. Besides, frequency-based and time domain performance requirements can also be posed in form of LMIs, as H_∞ , H_2 or pole placement.

LMI-based state-feedback synthesis methods have been already applied successfully in the field of power conversion, since they can be applied directly with no additional conservatism. However, output-feedback approaches require the linearization of the synthesis variables in order to be solvable with LMIs. Such linearization methods often impose changes in the matrix variables or require an initial feasible result.

The results presented in this chapter with LMI control of a buck and a buck-boost converter demonstrates the feasibility of this approach, but also shows some of the limitations.

The buck-boost converter presents nonlinear dynamics; such control problem has been tackled with a state-feedback approach, so that the information about the converter states allows to consider the uncertainty coming from the disregarded dynamics, but also limits the achievable performance. Such limitation also allows to neglect the sampling effect of the modulation, since the effective feedback bandwidth of the control is well below the switching frequency.

On the other hand, the control of the buck converter, whose averaged dynamics are basically linear, has been dealt with an output-feedback realization. In this case, the closed-loop performance and its associated bandwidth can reach high frequencies, and it is advisable to take into account the sampling effect of the modulator. From the comparison between the three output-feedback approaches, the best results have been achieved with the H_∞ -based dynamic controller, but this approach also presents some limitations, as the impossibility to deal with easy-to-derive uncertainty models. Another drawback of this technique is that the choice of appropriate weighting functions must be made by trial and error and therefore this task requires good knowledge of the plant limits. Nevertheless, such limitations also appear in the dynamic output-feedback approach by static parametrization, since the results strongly depend on the initial feasible solution for the iterative algorithm.

Depending on the application of the dc-dc converter, it may be easier to implement a state-feedback controller or an output-feedback controller. For instance, the inductor current may not be accessible or the capacitor stray resistance cannot be assumed small enough.

Future research on LMI control of power converters could focus on the improvement of the output-feedback synthesis algorithms, which still require the tedious task of selecting weighting functions, even for the initial controller of the static feedback parametrization. Besides of the inherent limitations of output-feedback, the synthesis algorithms are still very conservative and do not lead to tight performances, when compared with state-feedback approaches.

5. References

- Apkarian, P., Tuan, H. D. & Bernussou, J. (2001). Continuous-time analysis, eigenstructure assignment, and H_2 synthesis with enhanced linear matrix inequalities (LMI) characterizations, *IEEE Transactions on Automatic Control* 46(12): 1941–1946.
- Ben-Tal, A., El Ghaoui, L. & Nemirovski, A. (2009). *Robust Optimization*, Princeton Series in Applied Mathematics, Princeton University Press.
- Bernussou, J. (1996). *Commande Robuste*, Hermès, Paris (in French).
- Bernussou, J. & Oustaloup, A. (2002). *Conception des Commandes Robustes*, Systèmes Automatisés I2C, Lavoisier, Paris (in French).
- Bernussou, J., Peres, P. L. D. & Geromel, J. (1989). A linear programming oriented procedure for quadratic stabilization of uncertain systems, *Systems and Control Letters* 13: 65–72.
- Boyd, S., El Ghaoui, L., Feron, E. & Balakrishnan, V. (1994). *Linear Matrix Inequalities in Systems and Control Theory*, Vol. 15 of *Studies in Applied and Numerical Mathematics*, SIAM, Philadelphia.
- Brown, A. R. & Middlebrook, R. D. (1981). Sampled-data modeling of switching regulators, *IEEE PESC '81; Power Electronics Specialists Conference, Boulder, CO*, pp. 349–369.
- Courties, C. (1997). H_∞ robust control for polytopic uncertain systems, *Technical Report LAAS 97344*, Laboratoire d'Analyse et d'Architecture des Systèmes du CNRS.

- Courties, C. (1999). *Sur la commande robuste et LPV de systemes a parametres lentement variables*, PhD thesis, Institut National des Sciences Appliquées de Toulouse (in French).
- de Oliveira, M. C. & Geromel, J. C. (1997). Numerical comparison of output feedback design methods, *Proceedings of the American Control Conference, ACC'97*, Vol. 1, pp. 72–76.
- El Ghaoui, L. & Niculescu, S. (2000). *Advances in linear matrix inequality methods in control: advances in design and control*, Society for Industrial and Applied Mathematics, Philadelphia, PA, USA.
- Erickson, R. W. & Maksimovic, D. (1999). *Fundamentals of Power Electronics*, Kluwer Academic, Norwell, Massachusetts.
- Gahinet, P., Nemirovski, A., Laub, A. J. & Chilali, M. (1995). *LMI Control Toolbox for use with Matlab*, The MathWorks, Inc.
- Garcia, G., Tarbouriech, S., Gomes da Silva, J. M., J. & Castelan, E. B. (2004). Pole assignment in a disk for linear systems by static output feedback, *IEE Proceedings on Control Theory and Applications* 151(6): 706–712.
- Hu, T. (2011). A nonlinear-system approach to analysis and design of power-electronic converters with saturation and bilinear terms, *IEEE Transactions on Power Electronics* 26(2): 399–410.
- Leyva, R., Cid-Pastor, A., Alonso, C., Queinnec, I., Tarbouriech, S. & Martinez-Salamero, L. (2006). Passivity-based integral control of a boost converter for large-signal stability, *IEE Proceedings Control Theory and Applications* 153(2): 139–146.
- Löfberg, J. (2004). YALMIP : A toolbox for modeling and optimization in MATLAB, *Proceedings of the CACSD Conference*, Taipei, Taiwan, pp. 284–289. [Online] <http://control.ee.ethz.ch/~joloef/yalmip.php>.
- Maksimovic, D. (2000). Computer-aided small-signal analysis based on impulse response of dc/dc switching power converters, *IEEE Transactions on Power Electronics* 15(6): 1183–1191.
- Martenson, B. (1985). The order of any stabilizing regulator is sufficient a priori information for adaptive stabilization, *Systems and Control Letters* 6: 87–91.
- Montagner, V. F., Oliveira, R. C. L. F., Leite, V. J. S. & Peres, P. L. D. (2005). LMI approach for H_∞ linear parameter-varying state feedback control, *IEE Proceedings on Control Theory and Applications* 152(2): 195–201.
- Nett, C., Bernstein, D. & Haddad, W. (1989). Minimal complexity control law synthesis, part I: Problem formulation and reduction to optimal static feedback, *Proceedings of the American Control Conference, ACC'89.*, Pittsburgh, pp. 2056–2064.
- Olalla, C., Leyva, R., El Aroudi, A. & Queinnec, I. (2009a). Robust LQR control for PWM converters: an LMI approach, *IEEE Transactions on Industrial Electronics* 56(7): 2548–2558.
- Olalla, C., Leyva, R., El Aroudi, A. & Queinnec, I. (2010a). LMI robust control design for boost PWM converters, *IET Power Electronics* 3(1): 75–85.
- Olalla, C., Leyva, R., El Aroudi, A., Queinnec, I. & Tarbouriech, S. (2009b). Hinf control of DC-DC converters with saturated inputs, *Proceedings of the IEEE Annual Conference on Industrial Electronics, IECON'09*, Porto.
- Olalla, C., Queinnec, I. & Leyva, R. (2010b). *Robust linear control of DC-DC converters: A practical approach to the synthesis of robust controllers*, VDM Verlag.
- Olalla, C., Queinnec, I., Leyva, R. & El Aroudi, A. (2011). Robust optimal control of bilinear dc-dc converters, *Control Engineering Practice* 19(7): 688–699.

- Peaucelle, D. & Arzelier, D. (2001a). An efficient numerical solution for H_2 static output feedback synthesis., *European Control Conference*, Porto, pp. 3800–3805.
- Peaucelle, D. & Arzelier, D. (2001b). An iterative method for mixed H_2/H_∞ synthesis via static output-feedback., *IEEE Conference on Decision and Control*, Las Vegas, pp. 3464–3469.
- Peaucelle, D. & Arzelier, D. (2001c). Robust performance analysis using LMI-based methods for real parametric uncertainty via parameter-dependent lyapunov functions, *IEEE Transactions on Automatic Control* 46(4): 624–630.
- Pyatnitskii, E. S. & Skorodinskii, V. I. (1982). Numerical methods of Lyapunov function construction and their application to the absolute stability problem, *Systems and Control Letters* 2(2): 130–135.
- Rodriguez, H., Ortega, R. & Escobar, G. (1999). A robustly stable output feedback saturated controller for the boost dc-to-dc converter, *Proceedings of the IEEE Conference on Decision and Control, CDC'99*, Vol. 3, pp. 2100–2105.
- Scherer, C., Gahinet, P. & Chilali, M. (1997). Multiobjective output-feedback control via LMI optimization, *IEEE Transactions on Automatic Control* 42(7): 896–911.
- Skogestad, S. & Postlethwaite, I. (1996). *Multivariable Feedback Control: Analysis and Design*, John Wiley and Sons, New York.
- Sturm, J. (1999). Using SeDuMi 1.02, a MATLAB toolbox for optimization over symmetric cones, *Optimization Methods and Software* 11-12: 625–653. [Online] <http://fewcal.kub.nl/sturm>.
- Torres-Pinzon, C. A. & Leyva, R. (2009). Fuzzy control in DC-DC converters: an LMI approach, *Proceedings of the IEEE Annual Conference on Industrial Electronics, IECON'09*, Porto, pp. 510–515.
- Wallis, G. F. & Tymerski, R. (2000). Generalized approach for μ synthesis of robust switching regulators, *IEEE Transactions on Aerospace and Electronic Systems* 36(2): 422–431.
- Zhou, K., Doyle, J. & Glover, K. (1996). *Robust and Optimal Control*, Prentice-Hall, New Jersey.

IntechOpen

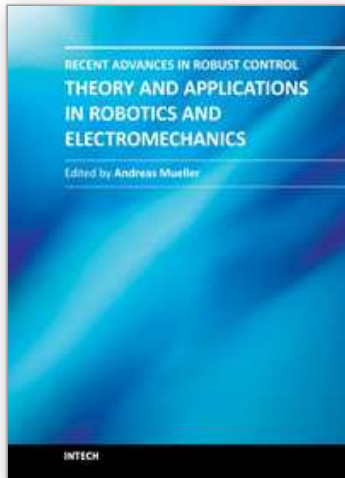

Recent Advances in Robust Control - Theory and Applications in Robotics and Electromechanics

Edited by Dr. Andreas Mueller

ISBN 978-953-307-421-4

Hard cover, 396 pages

Publisher InTech

Published online 21, November, 2011

Published in print edition November, 2011

Robust control has been a topic of active research in the last three decades culminating in H_2/H_∞ and μ design methods followed by research on parametric robustness, initially motivated by Kharitonov's theorem, the extension to non-linear time delay systems, and other more recent methods. The two volumes of Recent Advances in Robust Control give a selective overview of recent theoretical developments and present selected application examples. The volumes comprise 39 contributions covering various theoretical aspects as well as different application areas. The first volume covers selected problems in the theory of robust control and its application to robotic and electromechanical systems. The second volume is dedicated to special topics in robust control and problem specific solutions. Recent Advances in Robust Control will be a valuable reference for those interested in the recent theoretical advances and for researchers working in the broad field of robotics and mechatronics.

How to reference

In order to correctly reference this scholarly work, feel free to copy and paste the following:

Carlos Olalla, Abdelali El Aroudi, Ramon Leyva and Isabelle Queinnec (2011). LMI Robust Control of PWM Converters: An Output-Feedback Approach, Recent Advances in Robust Control - Theory and Applications in Robotics and Electromechanics, Dr. Andreas Mueller (Ed.), ISBN: 978-953-307-421-4, InTech, Available from: <http://www.intechopen.com/books/recent-advances-in-robust-control-theory-and-applications-in-robotics-and-electromechanics/lmi-robust-control-of-pwm-converters-an-output-feedback-approach>

INTECH
open science | open minds

InTech Europe

University Campus STeP Ri
Slavka Krautzeka 83/A
51000 Rijeka, Croatia
Phone: +385 (51) 770 447
Fax: +385 (51) 686 166
www.intechopen.com

InTech China

Unit 405, Office Block, Hotel Equatorial Shanghai
No.65, Yan An Road (West), Shanghai, 200040, China
中国上海市延安西路65号上海国际贵都大饭店办公楼405单元
Phone: +86-21-62489820
Fax: +86-21-62489821

© 2011 The Author(s). Licensee IntechOpen. This is an open access article distributed under the terms of the [Creative Commons Attribution 3.0 License](#), which permits unrestricted use, distribution, and reproduction in any medium, provided the original work is properly cited.

IntechOpen

IntechOpen