

We are IntechOpen, the world's leading publisher of Open Access books Built by scientists, for scientists

4,800

Open access books available

122,000

International authors and editors

135M

Downloads

Our authors are among the

154

Countries delivered to

TOP 1%

most cited scientists

12.2%

Contributors from top 500 universities



WEB OF SCIENCE™

Selection of our books indexed in the Book Citation Index
in Web of Science™ Core Collection (BKCI)

Interested in publishing with us?
Contact book.department@intechopen.com

Numbers displayed above are based on latest data collected.

For more information visit www.intechopen.com



Pressure-Sensitive Adhesives for Medical Applications

Zbigniew Czech, Agnieszka Kowalczyk and Jolanta Swiderska
*West Pomeranian University of Technology, Szczecin
Poland*

1. Introduction

Since their introduction half a century ago, pressure-sensitive acrylic adhesive has been successfully applied in many fields. They are used in self-adhesive tapes, labels, sign and marking films and protective films as well as in dermal dosage systems for pharmaceutical applications, in biomedical electrodes, plasters, the assembly of automotive parts, toys, and electronic circuits and keyboards.

In the last sixty years or so, pressure-sensitive adhesive (PSA) acrylics have made tremendous strides from what was virtually a black art to what is now a sophisticated science. So much so that both the few larger manufacturers of pressure-sensitive adhesive articles and their even larger suppliers now use very expensive equipment to study pressure-sensitive adhesive behavior: tack, adhesion and cohesion.

Three properties which are useful in characterizing the nature of pressure-sensitive adhesives are tack, peel (adhesion) and shear (cohesion). The first measures the adhesive's ability to adhere quickly, the second its ability to resist removal by peeling, and the third its ability to hold in position when shearing forces are exerted. Generally speaking the first two are directly related to each other but are inversely related to the third.

1.1 Definition

Pressure-sensitive adhesives (PSA) are nonmetallic materials used to bond other materials, mainly on their surfaces through adhesion and cohesion. Adhesion and cohesion are phenomena, which may be described thermodynamically and chemically, but actually they cannot be measured precisely. It was shown that the most important bonding processes are bonding by adhesion and bonding with pressure-sensitive adhesives.

In the long history of this technology, pressure-sensitive adhesives and tapes as we know them are a fairly recent concept. However, to trace their origins, one needs to study the history of adhesives as a whole, including the many failures and near misses along the way, as well as the fusion of various technologies, which eventually led to their development.

Since the dawn of history, people learned of the healing powers of certain leaves and plants. There is archaeological evidence indicating that adhesives have indeed been found on primitive tools. More than 6000 years ago, on the arrival of the Egyptian Civilization, the art of healing was already a profession. A primitive tape concept used by Egyptians was the use of a paste of starch in water applied to cloth strips. It indicates that surgical bandages, made of a mixture of fat and honey, were in use. There is very little known of the other raw

materials used in Egyptian/Greek times for surgical dressings. It is known, though, that resins, pitches and so on, were in common use in other trades and professions, for instance in the ship-building industry, and such resins would no doubt work well as tackifying resins in pressure-sensitive adhesive systems.

Pressure-sensitive adhesives were in wide use since the late 19th century, starting with medical tapes and dressings. The earliest was awarded in 1845. This was for a surgical pressure-sensitive adhesive that used natural rubber as the base, and pine gum as the tackifier, with balsam of Peru, turpentine, and spirits of turpentine also being added. Ninety years later Stanton Avery developed and introduced the self-adhesive label. Two major industries resulted from these innovations: pressure-sensitive tapes and labels.

In the late 1800s and early 1900s, the development first of the bicycle and then the automobile and their need for tires, allowed the rubber industry to flourish. Greater demands were placed on the industry to develop improved rubber-based products, and this improved technology naturally filtered into the existing adhesive tape industry. Industrial tapes were introduced in the 1920s and 1930s followed by self-adhesive labels in 1935. While various materials in roll form were available early in the 20th century that could have been used as adhesive tape backings, cotton cloth remained the backing of choice, with manufacturing geared to producing surgical tape. The history of PSAs was described by Villa.

Minnesota Mining and Manufacturing Company, popularly known as 3M, was the supplier of sandpaper to the automobile industry in the 1920s, their brand being known as "Wetordry". Richard Drew, then a laboratory technician for 3M would occasionally call at the automobile plants and body repair shops to take developmental samples of sandpaper for testing. There followed a whole series of patents by 3M on pressure-sensitive adhesive tapes, which laid the cornerstone of the industrial adhesive tape industry. The patents were awarded in 1933 for the transfer of his masking tape know-how to cellophane film, making the first pressure-sensitive film tape, giving the world the generic name of "Scotch" tape.

The major raw materials for pressure-sensitive adhesives in the mid-thirties were natural rubber, either as pale crepe, smoked sheet rubber, or wild rubber, with reclaim rubber for primer formulations, coumarone gum resin, burgundy pitch, pine oil, wood resin and gum olibanum as tackifiers, liquid paraffin, or mineral oil, lanolin and beeswax as softeners, zinc oxide as filler, with whiting as filler for prime coats, and benzole or low-boiling-point aliphatic petroleum hydrocarbons as solvent. There was little else available.

The elastomers in common use were polyisobutylene, or Oppanol B, polyvinyl isobutyl ether or Oppanol C, and some styrene butadiene, or Buna S. It is significant to note that as early as 1941 a polypropyl acrylic ester, known as Acronal 4, from I.G.Farben, was being used as a one component pressure-sensitive adhesive, the first indication of an acrylic pressure-sensitive adhesive system.

In the 1940s hot-melt adhesives were introduced. The post-war times brought with them exploration, and initial investigations began with balloons being sent into the stratosphere. It was soon learned that adhesives would be needed that were capable of functioning at extremely low temperatures. A research contract was to develop such an adhesive, and from it came Dow Corning's silicone pressure-sensitive adhesive, which could perform in the range from -62°C to $+260^{\circ}\text{C}$, the forerunner of other low/high temperature silicone pressure-sensitive adhesive systems.

However the fifties brought with them an acceleration of research work to convert the practice from an art to a science, and the mystery of tack and adhesion was explored in

depth. Also industrial adhesive tape companies began to communicate with one another for the common good of the industry. Acrylic pressure-sensitive systems, although still more than twice the cost of rubber-based systems, were not viable. For most companies this meant buying a commercial pressure-sensitive adhesive produced by someone other than themselves, so they lost the ability to manipulate by formula adjustment.

On the arrival of the 1970s, a very large proportion of the raw materials used by the adhesive tape industry were petroleum derived. The 1980s continued to bring raw material upgrades and new products, particularly in the area of alternate hot-melt elastomers, but little in the way of changes in pressure-sensitive adhesive technology. Product and process development in the industry continues in its upward spiral as can be seen by the number of related patents, which are granted every week throughout the world. Continuing environmental concerns now force the industry to look to other coating techniques than solvent-based systems, with calendaring the original technique still holding its own as a 100% solids system capable of laying down a heavy coat of adhesive at reasonably high speeds. Work continues to develop effective crosslinked hot-melt adhesive systems to replace those based on natural rubber, and water-based adhesive systems now becoming more viable, with a greater selection of raw materials to choose from, and with an improvement in economics. But the number and uses of pressure-sensitive adhesive and tape products continue to grow as the capability of the pressure-sensitive adhesive system improves, and as the user continues to be educated as to their potential.

At the end of the 1980s and during the early 1990s 3M, Beiersdorf, BASF and Lohmann presented the first solvent-free pressure-sensitive adhesive acrylics crosslinked with UV-radiation. Six years later 3M Company presented a new adhesive tape with pressure-sensitive thermosetting adhesives, the semi-structural adhesive tape.

The term PSA has a very precise technical definition and was dealt with extensively in the chemical literature. The function of PSAs is to ensure instantaneous adhesion upon application of a light pressure. Most applications further require that they can be easily removed from the surface to which they were applied, through a light pulling force. Thus PSAs are characterized by a built-in capacity to achieve this instantaneous adhesion to a surface without activation, such as a treatment with solvents or heat, and also by having sufficient internal strength so that the adhesive material will not break up before the bond between the adhesive material and the surface ruptures. The bonding and the debonding of PSAs are energy driven phenomena. Pressure-sensitive adhesives must possess viscous properties in order to flow and to be able to dissipate energy during the adhesive bonding process.

Polymers employed as PSAs have to fulfill partially contradictory requirements; they need to adhere to substrates, to display high shear strength and peel adhesion, and not leave any residue on the substrate upon debonding. In order to meet all these requirements, a compromise is needed. When using PSAs there appears another difference with wet adhesives, namely the adhesive does not change its physical state because film forming is inherent to PSAs.

Thus PSAs used in self-adhesive tapes are adhesives which through their viscoelastic fluid state, can build up the joint without the need to change this flow state during or after application. On the other hand, their fluid state allows controlled debonding giving a temporary character to the bond. Because of the fluid character of the bonded adhesive, the amount of adhesive (i.e., the dimensions of the adhesive layer) is limited; the joint works as a thin-layer tape, laminate or composite. The solid state components of the tape exert a

strong influence on the properties of the adhesive in the composite. Therefore, there exists a difference between the measured properties of the pristine adhesive, and of the adhesive enclosed within the laminate.

The properties, which are essential in characterizing the nature of PSAs comprise: tack, peel adhesion, and shear. The first measures the adhesive's ability to adhere quickly, the second its ability to resist removal through peeling, and the third its ability to hold in position when shear forces are applied.

1.2 Kinds of pressure-sensitive adhesives according to polymer groups

The pressure sensitive adhesive market includes a number of polymeric raw materials. There are used natural rubber, various types of synthetic rubber, such as styrene-butadiene and-ethylene co-polymers, polyvinyl ether, polyurethane, acrylic, silicones and ethylene-vinyl acetate-copolymers. However, basic pressure-sensitive adhesive formulations are acrylics, rubbers and silicones (Fig. 1)

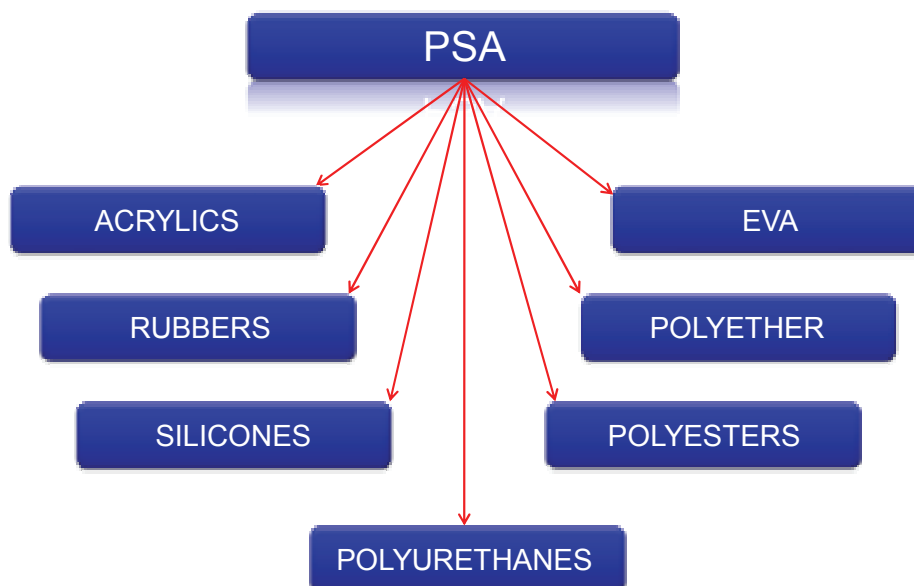

Fig. 1. Polymer classes as potential raw materials for the manufacture of PSAs

Typical performances of those three groups, such as tack, peel adhesion, shear strength, UV-resistance, solvent, chemical, plasticizer and thermal resistance, colour, costs and other important properties are presented in Table 1.

Rubber-based pressure-sensitive adhesives consist of natural or synthetic rubber, various resins, oils, and antioxidants. Blending rubber with tackifiers produces high quality PSAs, the properties of which are determined by tackifier. Because natural rubber is expensive addition of fillers modify properties and reduce costs as well. Other components, such as antioxidants, included protecting the unsaturated backbone polymer from degradation, pigments, plasticizers, and fillers are also added. Rubber-based adhesives are said to be the most cost-effective PSA system. However, long-term aging stability is low. Most of rubbers PSAs are produced as 35 % solution in hexane, similar petroleum fraction, or toluene. Synthetic polyisoprene use in PSA has poorer cohesive strength and his production costs are higher, then natural rubbers PSA.

Property	Acrylic	Rubber	Silicone	Polyurethane	Polyester	Polyether
Tack	Low to high	Typically high	Typically low	Typically low	Medium to high	Medium
Peel adhesion	Medium to high	Moderate to high	Low to moderate	Low to medium	Medium to high	Low to medium
Cohesion	Low to high	Moderate to high	High	Low to medium	Low to medium	Low to medium
UV resistance	Excellent	Low	Excellent	Excellent	Excellent	Excellent
Solvent/chemical resistance	High	Good	Excellent	High	Medium	Excellent
Plasticizer resistance	Low to medium	Generally low	Good	Medium	Medium	Low to medium
Humidity resistance	Excellent	Excellent	Excellent	Excellent	Medium	Excellent
Temperature range	-40 to 160°C	-40 to 70°C	-50 to 260°C	-30 to 120°C	-30 to 140°C	-40 to 120
Adhesive colour	Clear to straw	Yellow (more with time)	Clear	Clear to straw	Clear	Clear
Cost	Medium	Low	High	High	Medium to high	Medium
Other characteristics	Good hydrolysis resistance	Good adherence to low and high energy surfaces	Good adherence to low and high energy surfaces	Good removability	Good flexibility	Excellent flexibility
	Easy to apply	Good flexibility	Good oxidation resistance			

Table 1. Typical performance of the basic adhesive formulations

Acrylic-based pressure-sensitive adhesives are made from higher alkyl esters of acrylic acid without need of tackifiers and provide excellent physical properties. Monomer composition and molecular weight of the polymer determine most of the adhesive's properties. Because acrylic PSAs can be free of those additions, they are less irritating to skin and often preferred to medical applications. Nevertheless, many commercial acrylic PSAs are formulated with other components such as tackifiers, antioxidants, pigments, and fillers. Modified acrylic adhesives contain tackifiers that improve initial tack and adhesion levels while decreasing resistance to solvents, plasticizers, and high temperatures. Acrylic PSAs have superior environmental stability, adhesion to high surface energy materials and greater resistance to oxidation when compared with rubber-based PSAs. In addition, they are more stable to light and heat. The dominate raw materials used for production PSAs are acrylic esters of C₄-C₁₂ alcohols, from which the most commonly use are butyl acrylate and 2-ethylhexyl acrylate. Acrylic PSAs are applied in solution, water dispersion or in form of 100 % systems, which are hot-melts or LVS-low viscosity systems also known as room-temperature RT-coatable PSAs. They are used for a multitude of types, labels, protective films, sign and market films, medical products.

Property	Solvent-borne PSAs	Water-borne PSAs	Solvent-free PSAs
Solid content, %	20–50	40–69	100
Drying rate	Usually fast, drying time adjustable by choice of solvents	Slow to dry; however, high solids content meant less to dry	No volatiles to evaporate
Surface wet-out	Excellent on most surfaces, even without minor contamination	Good on porous substrates, poor to fair on non polar surfaces like plastics	Good on most surfaces, may require heating the surface before application
Water resistance	Usually good to excellent	Fair to good	Excellent
Temperature range	–55 to 160°C	–40 to 120°C	–45 to 140°C
Surface attack	May cause degradation of some plastic and paint	Causes shrinkage and wrinkling of fabric and paper; corrosive to metal	Usually no problem; heat may deform thin plastics
Flexibility	Excellent	Excellent	Excellent
Hazards	Requires vapour control; many are flammable and many require emission control	Usually no problem; some have trace levels of chemicals that require control of vapours	Few problems other than working with hot dispensing equipment
Cleanup	Solvent	Water when wet; solvent when dry	Solvent
Cost	Low to moderate cost per gallon; <i>high cost per dry unit of weight</i>	Moderate cost per gallon; <i>low cost per dry unit of weight</i>	<i>Moderate cost per dry unit of weight</i>

Table 2. Properties and characteristic of pressure-sensitive adhesives

Silicone-based pressure-sensitive adhesives are made from two basic components, which are resin and a gum. The resin is obtained from reaction of silicic or polysilicic hydrosol with trimethylchlorosilane. The gums are high molecular weight linear polysiloxane polymers. The simplest method of PSA preparation is mixing resin and gum in a suitable solvent, typically toluene. The physical properties of the silicone PSA depend on resin/gum ratio, type of gum and the heating of the blends in toluene. Silicone PSAs are the only PSA that consistently bond to silicone substrates, also they have excellent high temperature stability over 500°C, flexibility over a wide temperature range, unique adhesion to surfaces of both high and low surface energy. Despite of those superb properties, silicone-based adhesives are expensive in relation to other types of systems, and they have low initial tack and adhesion.

Another group of PSAs is poly(vinyl alkyl ether) blends. That polymers group are mostly use in medical application, especially poly(vinyl ethyl ether) because of his high moisture vapour permeability, valuable for patient comfort during long-term application to the skin. Also is used poly(vinyl isobutyl ether). The production involves blending high and low molecular weight polymers, from which low MW polymer provides spreading on the adherent surface and the high MW polymer determine cohesive strength.

1.3 Kinds of pressure-sensitive adhesives according to synthesis methods

Pressure-sensitive adhesives are applied from solvent solutions, water dispersions or solvent-free systems. After that, they form a permanent tacky film after the evaporation of the solvent or weather phase or after cooling of a hot-melt. Bonding is affected by slightly pressing the adhesive surface onto the adherend. These three groups can demonstrate different properties (Table 2).

Solvent-borne adhesives are synthesized in solvent and are coated onto a web. Following coating, the solvent evaporates, leaving a functional adhesive. Solvent-borne PSA acrylics offer several advantages such as excellent aging characteristics and resistance to elevated temperatures and plasticizers, exceptional optical clarity due to the polymer compatibility and non-yellowing. They also have the highest balance of adhesion and cohesion and an excellent water resistance. The numerous advantages of solvent-based acrylic PSA have led to their wide use in the manufacture of self-adhesive products.

Solvent-free system and emulsion are two additional types of adhesives. Emulsion adhesive ingredients are polymerized in water, applied to the web and dried to create a functional adhesive. Solvent-free as hot-melt adhesives are made from thermoplastic rubbers that formulate with tackifying resins, oils, and antioxidants to achieve coating on the web at high temperatures. Solvent-free pressure-sensitive adhesives are relatively new group of self-adhesive technical and medical products and demonstrate many advantages in opposite to solvent-based pressure-sensitive adhesives. The main aspect is reduction of environmental impact to a minimum during production and exploitation.

Advantages and disadvantages of those three PSAs group are presented in Table 3.

1.4 Main properties of pressure-sensitive adhesives

The term pressure-sensitive describes adhesives, which in the dry form are aggressively and permanently tacky at room temperature and firmly adhere to a variety of dissimilar surfaces upon mere contact, without the need of more than finger or hand pressure. PSAs possess adhesion, required for bonding and debonding, and cohesion necessary against debonding. Adhesion is characterized by tack and peel, whereas cohesion is described by shear resistance, and partially by peel. The special balance of these properties, the adhesion/cohesion balance, embodies the pressure-sensitive character of the adhesive. The efficiency of the bonding process is related to the adhesive's ability to exhibit viscous flow. In order to achieve peel adhesion the bonding stage involves some dwell time. During this time the adhesive must flow in the absence of any externally applied forces. The more liquid-like the behavior of the polymer under these conditions, the more pronounced the degree of bond formation. The debonding process involves a more rapid deformation of the adhesive mass. The polymer's resistance to deformation at higher strain rates becomes very important; the higher this resistance, the higher the force which must be applied to separate the adhesive from the adherent (i.e. the peel resistance). Therefore, high tack, high peel strength adhesives should exhibit good flow at low strain rates, but good resistance to flow

at higher strain rates. A proper balance between high tack, peel adhesion, and high cohesion is necessary in most cases. The behavior of any pressure-sensitive adhesive can be reduced to three fundamental and interconnected physical properties: tack, adhesion (peel adhesion), and shear resistance (cohesion). A clear understanding of each property and term is essential.

Pressure-sensitive adhesive	Advantage	Limitation
Solvent-borne	Quick drying	Flammability
	Form homogenous films	Toxicity
	Good adhesion to non polar substrate	Relatively low solid content
	Good key on certain plastics	Difficult cleaning
Water-borne	Easy cleaning	Slow drying
	Good adhesion to polar substrates	Require heat to dry
	Good heat and ageing resistance	Poor adhesion on non polar substrates
	Environment friendly	Presence of surfactant
	High solid content	
Hot-melt	100% active	High equipment costs
	Environment friendly	Require heat
	Very fast setting	Thermal degradation
		Difficult to clean
		Can melt the substrate

Table 3. The advantages and limitations of solvent-borne, water-borne and hot-melt PSA

1.4.1 Tack (initial adhesion)

Tack has been one of the favorite subjects of theorists over many years, often resulting in the derivation of complex formulae in an attempt to explain the property. Nevertheless, tack is still considered and rated by many as how well a pressure-sensitive adhesive sticks to the finger following only slight pressure and short dwell time. While in many cases this can be an approximate measure, this method is badly flawed in that it is highly subjective.

When a pressure-sensitive adhesive is applied to a surface, it takes time for that adhesive to wet out the surface until optimum contact area and adhesion is achieved. This time may be a small fraction of second, or may take days or even weeks. The wetting process can be aided by the degree of pressure applied and the length of time given to that pressure. The rate at which wetting take place varies inversely with the amount of surface still available for wetting. Because the rate of wettability can be considerably accelerated by applied pressure, in a number of tests this application pressure is reduced to a minimum to increase the sensitivity of the test. In summation, the tack of a pressure-sensitive adhesive can be considered to be primarily a measure of the wettability of that adhesive under controlled application conditions, with due regard for its optimum adhesion value. Tack increases continuously upon adding soft, viscous components to the formulation.

1.4.2 Peel adhesion (adhesion)

High peel adhesion requires certain tack level for bonding and certain cohesion for debonding. The dependence of the peel on the ratio of elastic/viscous components is more complex, going through a maximum as a function of the level of the soft component. There are two meanings of the term "adhesion". On the one hand, adhesion is understood as the process through which two bodies are attached to each other when brought together. In this sense adhesion characterizes the sum of all intermolecular and electrostatic forces acting across the interface. On the other hand, we may examine the process of breaking the already adhesive in contact. In this case adhesion is the force, or the energy, required to separate the two bodies, often called "practical adhesion" or "adherence".

One would believe that in describing the adhesion of a pressure-sensitive adhesive in the form of tapes it would be a measure of the force that holds that pressure-sensitive adhesive tape to an applied surface. In fact, though, it is actually a measure of the force required to remove it from that surface. Removal involves work done in extension of the adhesive, the work done in distorting the backing during the stripping action, and the work done in separating the adhesive/surface interface, the last being the smallest of the three. According to ASTM (American Society for Testing Materials), adhesion is "a state in which two surfaces are held together by interfacial forces which may consist of valence forces or interlocking action, or both".

Many theoretical models of adhesion have been proposed, which together are both complementary and contradictory: mechanical interlocking, adsorption (or thermodynamic) theory, electrostatic theory, chemical bonding theory, diffusion theory of adhesion, adhesive effect of thin liquid films and theory of weak boundary layers. Each of these theories of adhesion is supported by experimental analysis but for each there are also convincing counter arguments.

1.4.3 Shear strength (cohesion)

According to ASTM definitions of cohesion include "The propensity of a single substance to adhere to itself, the internal attraction of molecules towards each other; the ability to resist partition from the mass; internal adhesion; the force holding a single substance together". The most important means to influence the cohesion of PSAs are tackification and crosslinking. PSAs possess typical viscoelastic properties, which allow them to respond to both a bonding and a debonding step. For permanent adhesives the most important step is the debonding one; the adhesive should not break under debonding (mainly shear and peel) forces (i.e., permanent adhesives must provide a higher level of cohesive or shear strength than removable adhesives).

At one end of the spectrum, with a high stress or a rapidly increasing stress, the behavior will be largely elastic and the adhesive will separate at the interface leaving a trace of adhesive residue, or the tape backing will break. At the other end of the spectrum, the liquid component of the adhesion can respond fully, allowing molecular disentanglement within the adhesive resulting in cohesive failure.

Typical shear resistance testing is performed with a controlled area of adhesive tape (pressure-sensitive adhesive layer) applied to a standard test surface. Because shear failure is the inability of the pressure-sensitive adhesive to resist a continuous stress, any task that is a measure of stress relaxation within the adhesive gives meaningful data. A high shear resistant adhesive will maintain the stress, while a poor shear resistant adhesive will relieve the stress quite rapidly.

1.5 Characteristic of medical quality of pressure-sensitive adhesives

The focus of the development of self-adhesive medical products is on one hand directed towards customer-oriented requirements such as adhesion, biocompatibility and permeability for water vapor or air. The customer wants highly tolerable, breathable products which are also characterized by very good skin and optimal release. On the other hand, the economic targets of medical-products manufactures must be considered.

The three domains: kind of raw material, technologies and application, supply the basis for the trends of the development of adhesives for medical products. The use of highly tolerable substances with minimal allergenic potential is the primary factor with regard to raw materials. Additionally, the choice is limited by other external influences too.

Pressure-sensitive adhesives (PSA) for stick-to-skin medical products are required to perform a wide variety of tasks under a range of conditions on a complex and highly variable substrate. The origins of something like PSA go back to ancient Egypt, and the first modern adhesive was patented in 1845. Although, the materials have evolved, they had the elements that we recognize today, including an elastic polymer, an adhesion resin, filler and plasticizer.

Nature rubber became a standard base for adhesives, and in 1899, Johnson and Johnson introduced a zinc oxide-containing cloth-backed tape. Shortages of materials during World War II led to a proliferation of synthetic polymers, and by the 1960s, when polar comonomers were used to give cohesive strength to the polymer, acrylic adhesives began to dominate the medical field because of their inherent tack, good oxidative stability and easy adaptability to a variety of needs.

Today, medical devices are called upon to meet a multitude of needs, and are formulated accordingly. Tapes are used to secure dressing and devices, with gentleness, low cost, security, breathability or other characteristics being of primary importance, depending on the particular application. A so-called "paper" tape, which has a non-woven backing coated with a thin and often porous coating of adhesive [5], is chosen for low-stress applications such as securing a surgical dressing, where low cost is important and moderate adhesion is sufficient.

Transparent dressings are widely used to cover and protect superficial wounds. They consist of thin, breathable polyurethane films coated with acrylic adhesives. Since they function as bacterial barriers, their generally high-moisture vapor transmission is accomplished by diffusion of water through the adhesive and backing layers. The more effective adhesives have hydrophilic character and are lightly crosslinked by gamma radiation during the sterilization process.

As a surface to which medical adhesives must stick, skin presents a substantial challenge. It is the largest organ of the body, averaging 3 000 square inches and seven pounds in an adult. As the interface between the body and the outside world, it provides protection against microbial invasion, controls perspiration for temperature regulation, limits transpiration for moisture and provides sensory information.

Skin is a very complex organ. It is made up of two layers. The lower layer is the dermis, whose two major proteins, collagen and elastin, form a matrix that supports the outer layer called the epidermis. Skin is highly variable with gender, age, ethnicity, location on the body and ambient conditions. It is also a structurally weak surface. The top layer, called the stratum corneum, is made of cells that migrated from the base of the epidermis and are being sloughed off as the skin renews and replenishes itself.

The body sheds roughly 10 million cells per day, or about 10 thousand per minute of walking. Skin turns over completely in about 20 to 30 days. So medical adhesive devices must stick to layer that is being shed. It is also a very rough surface, with hair, folds, creases, pores for sweat and oil glands, and wrinkles. The surface energy of skin is also low and adhesion is further compromised by contamination with water, oils, salts and loose debris. As a consequence of these characteristics, there is an upper limit on how much adhesion can be achieved [6], since surface contact is limited and failure of the adhesion bond occurs mostly in the stratum corneum.

Material	Critical surface-energy [mN/m]	Polar [%]
Skin	25-29	40
Polyethylene	31	3
Teflon	18	0,2
Water	72	68

Table 4. Skin as low-energy surface

Pressure-sensitive adhesives for skin need to have a combination of traits that are unique compared to general-purpose adhesive products. Because a medical device is applied to a body that is compromised by acute, chronic, or systemic conditions, it is important that no component in the adhesive aggravate the system further. Obviously, there should be no toxic components that can be absorbed through broken or compromised skin but also there should be nothing that causes an allergic sensitization, response or an acute chemical irritation. Common sources of concern are unreacted free monomers, stabilizers, crosslinking agents, residues from initiators surfactants and processing aids.

In use, an adhesive needs to have good water resistance, both to applied water from outside, such as from bathing or leaking tubes, and to water from under a tape or dressing in the form of perspiration, blood or wound exudates. The self-adhesives need to retain sufficient cohesive strength when wet so the device can be removed cleanly without leaving any adhesive residue and without relevant changes in removal force. In addition, because skin transpires water vapor into the air, an adhesive device also needs to allow enough water diffusion so the skin tissue does macerate and eventually break down.

Quality control of PSAs for medical applications requires, in addition to a simply identity check, also more detailed analyses like proof of homogeneity or quantitative composition. Commonly used methods for quality control of PSAs medical grade are GC-chromatography (residue monomers), IR-spectroscopy (presence of additional derivatives) and typical rheological methods as K-value, peel adhesion on defined substrates and holding power tests. Rheological test methods offer, due to specific geometry and stress, the potential to analyze of viscoelastic properties of PSAs, important at application on skin and independently of test equipment.

2. Acrylic pressure-sensitive adhesives

The composition of acrylic polymers that are inherently pressure-sensitive is a combination in the polymer chain of soft (low glass transition temperature T_g), hard (high glass transition temperature T_g) and functional monomers (Fig. 2). Normally acrylic PSAs contains typical hard and soft monomers, as well as the types of functionality that can be incorporated into the polymer chain.

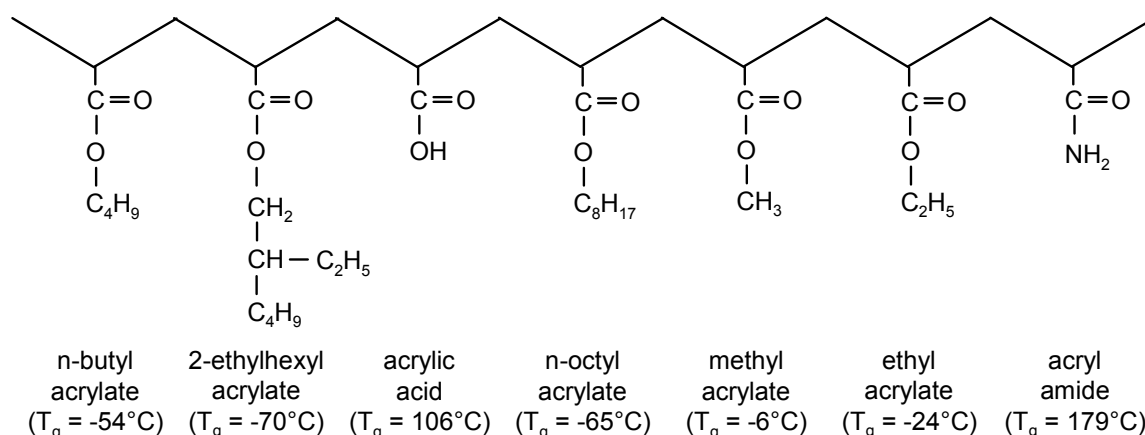

Fig. 2. Typical chain of acrylic PSA copolymer

Solvent-borne, water-borne and solvent-free acrylic PSAs are nowadays predominantly manufactured by polymerization from a wide selection of acrylic, methacrylic and other monomers, often with low levels of monomers having pendant functional groups in a refluxing organic solvent in the presence of an initiator, such as organic peroxides or azo compounds: Solvent-borne PSA acrylics offer several advantages such as excellent aging characteristics and resistance to elevated temperatures and plasticizers, exceptional optical clarity due to the polymer compatibility and non-yellowing. They also have the highest balance of adhesion and cohesion and an excellent water resistance. Lower adhesion to non-polar polyolefins is caused by the polar chemistry of acrylics. Acrylics polymer chemistry is expanding through the introduction and utilization of new raw materials, new polymerization process, new modification methods, new crosslinking agents and new crosslinking kind and technology.

2.1 General properties

Although the pressure-sensitive acrylic adhesives may be dwarfs in terms of quantity, they are giants when considered from the quality point of view. Only by means of these acrylic specialties was it possible to succeed in drafting the present surprisingly efficient generation of medical pressure-sensitive adhesive tapes and other self-adhesive materials medical grade for prominent assembly projects at justifiable cost for medical applications.

The most important requirements for a pressure-sensitive adhesive, such as high tackiness (adhesion by the touch), high cohesion (inner stability), high stickiness (adhesion), UV, solvent and temperature stability are fulfilled by acrylics in an outstanding way.

Solvent-borne, water-borne or solvent-free acrylic PSAs offer several advantages such as excellent aging characteristics and resistance to elevated temperatures and plasticizers, exceptional optical clarity due to the polymer compatibility, non-yellowing and free of residual monomers. They also have the highest balance of adhesion and cohesion and an excellent water resistance. Acrylics are harder than rubbers. This can be seen in a less aggressive tack and slower build-up of peel strength. Lower adhesion to non-polar polyolefins is caused by the polar chemistry of acrylics.

2.2 Special properties for medical quality

Acrylic pressure-sensitive adhesives are available on the market as the major types in form of solvent-born, water-borne or 100% polymer systems, which can be tailor-made for defined product purposes.

The target function of adhesives, especially acrylic PSAs, which can be used for skin adhesion, can be concentrated on three basic characteristics. The fast skin wetting during initial adhesion and the secure adhesion on skin within the application time as well as the complete removability after application. A balanced relationship between these three basic characteristics is the primary aim of the formulation of pressure-sensitive adhesives for skin application.

Nowadays, the medical self-adhesive products represent a vast part of the total adhesive materials on the medical market. It all started a long time ago already two centuries ago, in Europe, a druggist issued the first patent on a medical tape. In 1882 Paul Beiersdorf claimed a patent for a "medical plaster". Since then, the production of PSA products started for hospital and first-aid applications. It took until the 1920's before the benefits of PSA products were introduced in industrial applications. Today, medical products do more than merely fixing medical dressings to the body. Over the years, the investigations in medical PSA technology have concentrated on a wide range of formulations to tailor adhesive properties to meet specific needs, resulting in the development of PSA's that form a vital part of the modern wound care dressings.

Although the medical self-adhesive materials can be classified in similar categories as typical technical industrial products, their performance and composition differs significantly for similar technologies. Medical self-adhesive products are mainly applied to human skin. It is this complex substrate which requires a unique approach for the formulation and production of medical PSAs. In order to develop a suitable medical skin adhesive, it is important to understand the basics of skin anatomy and physiology.

2.3 Medical applications

The focus of the development of self-adhesive medical products is on one hand directed towards customer-oriented requirements such as adhesion, biocompatibility and permeability for water vapor or air. The customer wants highly tolerable, breathable products which are also characterized by very good skin adhesion and optimal release. On the other hand, the economic target of medical-product manufactures must be considered. Typical aspects would be an increase in machine speed and the reduction of manufacturing costs as well as the corresponding environmental aspects concerning both product and process.

The three domains, namely raw materials, technologies and application, supply the basis for the trends of the development of adhesives for medical products. The use of highly tolerable substances with minimal allergenic potential is the primary factor with regard to raw materials. Additionally, the choice is limited by other external influences.

One example of this is discussions concerning the integration of animal-derived raw material for the manufacturing of medical products. Furthermore, the requirements of the raw material with regard to the characteristics of the finished products and easy processability are continuously increasing. During the development of the process, those technologies are to be preferred where critical products such as organic solvents are avoided. Typical examples are hot-melt systems, water-borne adhesives and solvent-free acrylic systems. Also, those systems where serious savings can be achieved with regard to process time and investments are focused upon as a major point of interest.

New applications of self-adhesive acrylic medical products are aimed at developing easier handling or other additional unique selling propositions. There are medical systems, for example, where medication is achieved by means of drug supply through the simple applications of an island dressing. Typical medical application of acrylic pressure-sensitive adhesive medical grade extend over plaster and pads, transdermal drug delivery systems (TDDS), OP-tapes, biomedical electrodes, self-adhesive hydrogels and surgical drapes.

2.3.1 Plaster and pads

Medicinal plasters (Fig. 3) and pads have been utilized around the globe for centuries to treat multiple ailments both topical and systemic. History teaches us that as far back as 14th century China, certain plants were being ground and placed on the skin for the purpose of malady containment and cure. As an evolutionary step, ointments, creams and gels have been developed over the years to treat everything from toothaches and mosquito bites to rheumatoid arthritis and melanomas, thus attesting to the viability of the skin as a delivery portal for topical and systemic drugs.



Fig. 3. Self-sticking plasters

2.3.2 Transdermal drug delivery systems (TDDS)

Physicians and hospitals make every effort to ensure that patients actually complete the course of medication therapy that is prescribed. If the medication is in the form of self-administered oral drugs or injections it is not easy to monitor compliance with the prescribed course. The development of systems that allow the controlled delivery of drugs through the skin a “therapeutic patch” was therefore welcomed by the medical profession with enthusiasm. Transdermal drug delivery systems (TDDS) offer real, practical advantages to the patient by releasing precise amounts of medication through the skin directly into the blood stream. Once the patch is applied to the skin no further action is required of the recipient-the patch continues to administer a uniform dosage over an extended period of time.

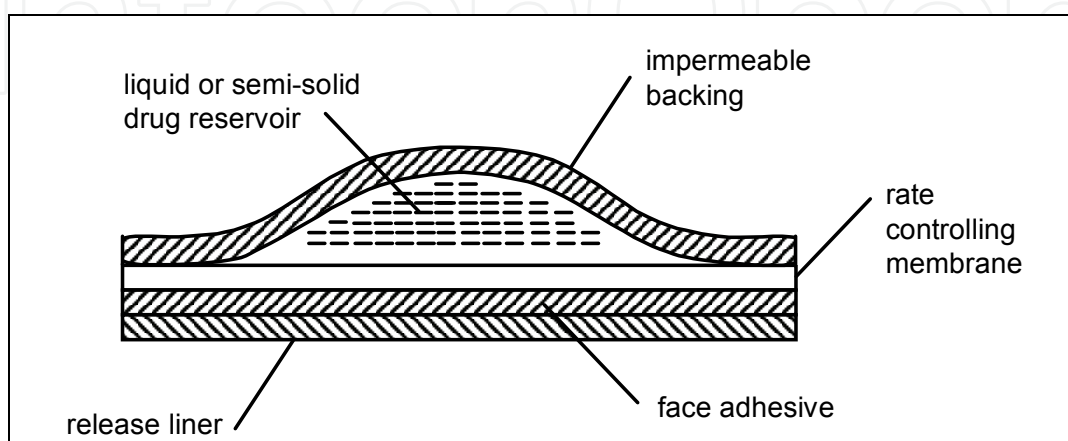

Fig. 4. Reservoir transdermal system with face adhesive

Transdermal drug delivery systems (TDDS) constitute evolutionary step in the passage of active agents through the skin. Transdermal drug delivery is complex but essentially comprises a drug reservoir with a protective outer cover, a permeable membrane (sometimes), a self-adhesive and a release liner. Figures 4 to 8 represent designs of the commercially available transdermal drug delivery systems.

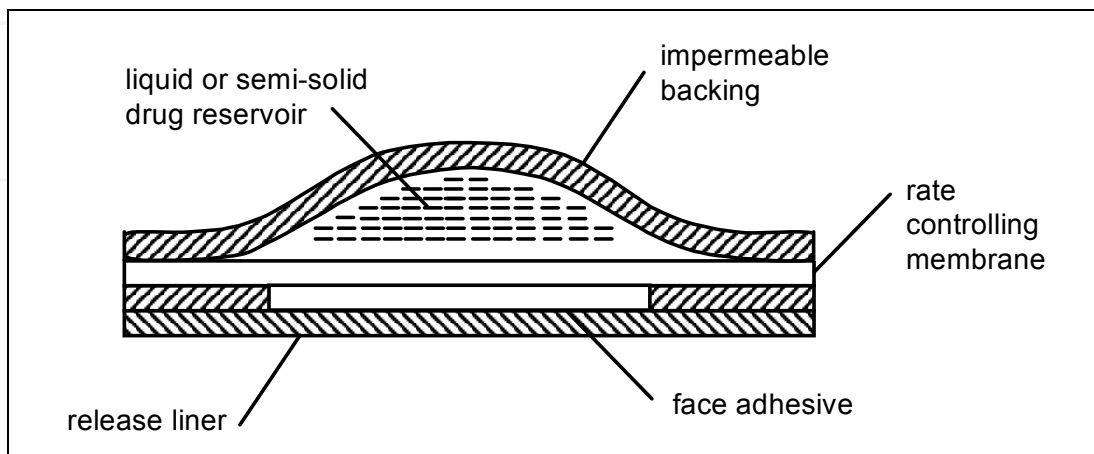

Fig. 5. Reservoir transdermal system with perimeter adhesive

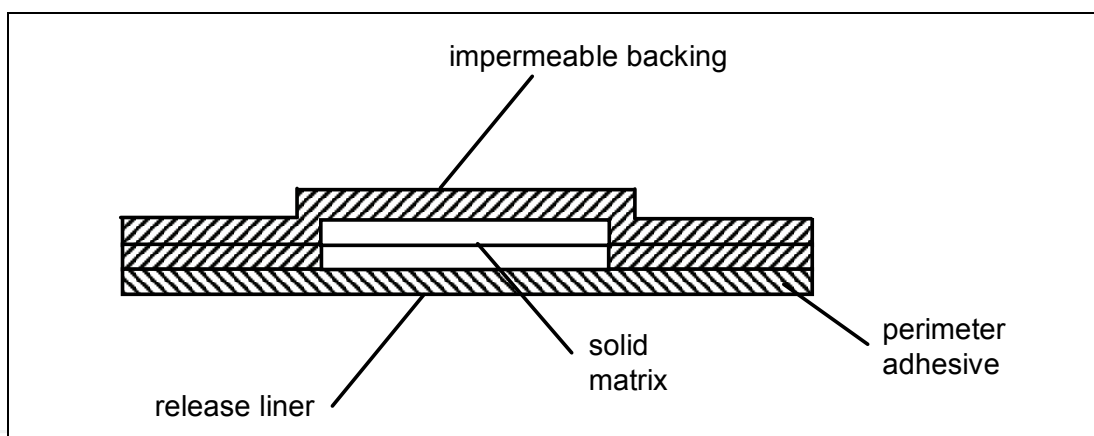

Fig. 6. Solid matrix transdermal systems with perimeter adhesive

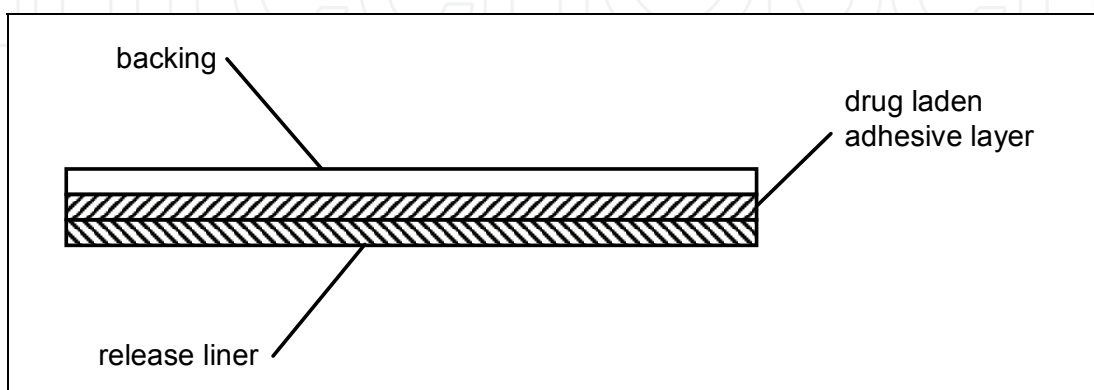

Fig. 7. Drug-in-adhesive transdermal systems

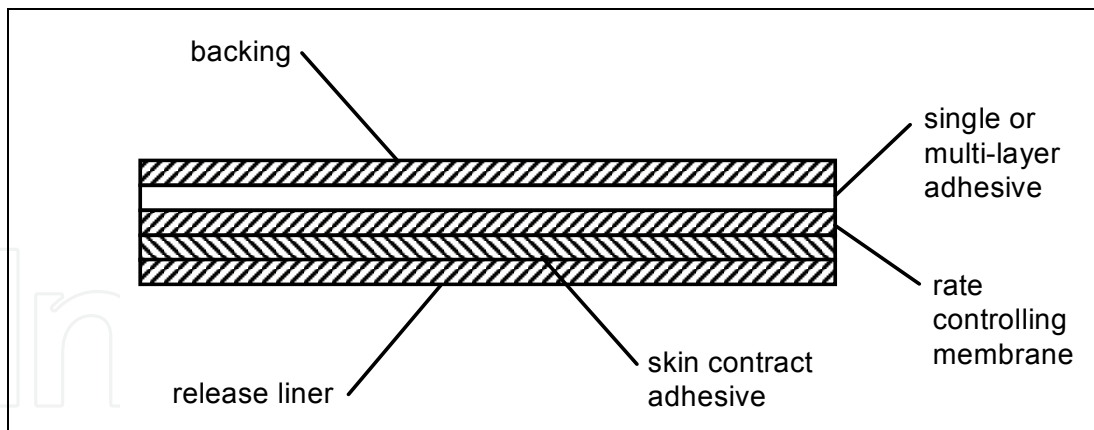

Fig. 8. Multilayer drug-in-adhesive transdermal systems

Figure 9 shows the typical TDDS construction for diverse drugs usable in medical applications.

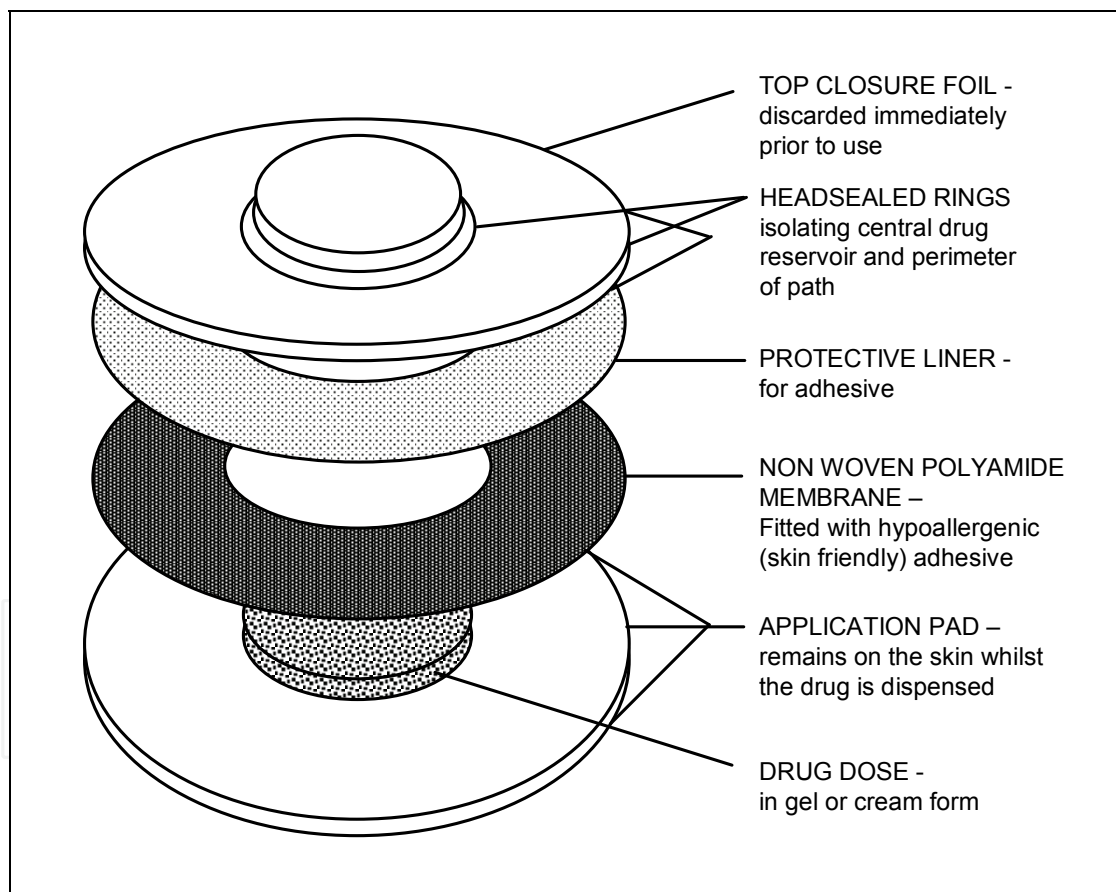

Fig. 9. TDDS construction

Health practitioners make every effort to ensure that patients actually complete the course of the prescribed medication therapy. If the treatment is in the form of self-administered oral drugs or injections it is difficult to monitor compliance with the prescribed course. Therefore the development of systems that allow the controlled delivery of drugs through the skin using a “therapeutic patch” was warmly welcomed by the medical profession.

Following the pioneering work by the California-based Alza Corp. with Ciba-Geigy at 80-ties, the first commercial TDDS products were patches containing scopolamine for motion sickness and nitroglycerine (NTG) for angina sufferers. NTG TDDS significantly reduced the risk of myocardial infarction. This success stimulated the search for other drugs suitable for sustained transdermal delivery. At least 30 projects has been now known to be under development, including patches to treat sexual dysfunction, depression, Parkinson and even Alzheimer disease. Beside the ongoing research the following drugs are available in TDDS form: scopolamine, NTG, clonidine, nicotine, estradiol, testosterone, norethindrone acetate, fentanyl, lidocaine.

The benefits of transdermal route of drug delivery may be best seen in gynecology. This includes hormone replacement therapy and contraception. Oral administration of estradiol derivatives is associated with a significant risk of vascular complications: thromboembolism and myocardial infarction. Women at major risk are smokers, patients with atherosclerosis and thrombophilias (carriers of clotting factor mutations), with a history of deep venous thrombosis or coronary heart disease. Oral administration of estrogens changes metabolism of liver dramatically. Some metabolic pathways are stimulated while others are partially blocked. While administered orally, the first pass effect modulates synthesis of important clotting factors, which results in altered activity of factors II, VII, IX and X as well as proteins S and C. This pathological state of "hypercoagulation" may lead to formation of thrombi and clinical complications like DVT, pulmonary embolism, myocardial infarctions or cerebrovascular accidents.

The risk of oral hormone replacement therapy (HRT) among menopausal women has its reflection in the results of women health initiative (WHI) study. Since the results have been published, the demand for the oral HRT has declined dramatically. On the other hand the transdermal administration of estradiol and progestins avoids liver portal circulation, thus at least theoretically decreases the risks related to the hormonal treatment. However the evaluation of the true safety of transdermal route of hormone administration awaits further meticulous research.

American data derived from women and health care practitioners indicate that women desire user-friendly contraception simplifying their lives. Despite enormous progress made in the field of contraception, in fact there are only 2 effective methods: hormonal contraception and intrauterine devices. The latter method bears significant risks therefore administration is narrowed to limit group of patients. On the other hand hormonal contraception, also not completely free from potential complications, requires patients to be very compliant.

Data from clinical studies are surprising. At least 1/3 of pregnancies are unplanned. Among this, 2/3 happen in women using contraceptive methods. It has been established that among women taking combined oral contraceptive pills, at least 60% of unintended pregnancies resulted from errors of daily drug administration. Efficacy of contraception is measured by Pearl index (PI). PI is determined by the number of unintentional pregnancies related to 100 women years. For instance, a hundred women can use contraception for a year, each with a method that is going to be examined. If five pregnancies occur during this time in this studied group, the Pearl index is 5.0. The theoretical PI for oral combined contraceptives is 0,3 which reflects perfect use of the method. However the practical PI may reach even 8,0, which reflects common errors made by pill users. About 10 to 30 % of women forget up to 3 pills in the cycle. This observation helps explain the differences between theoretical and practical values. Figure 10 clarifies the detrimental consequences of non-compliance in pill users, and shows the benefits of transdermal administration of the hormones.

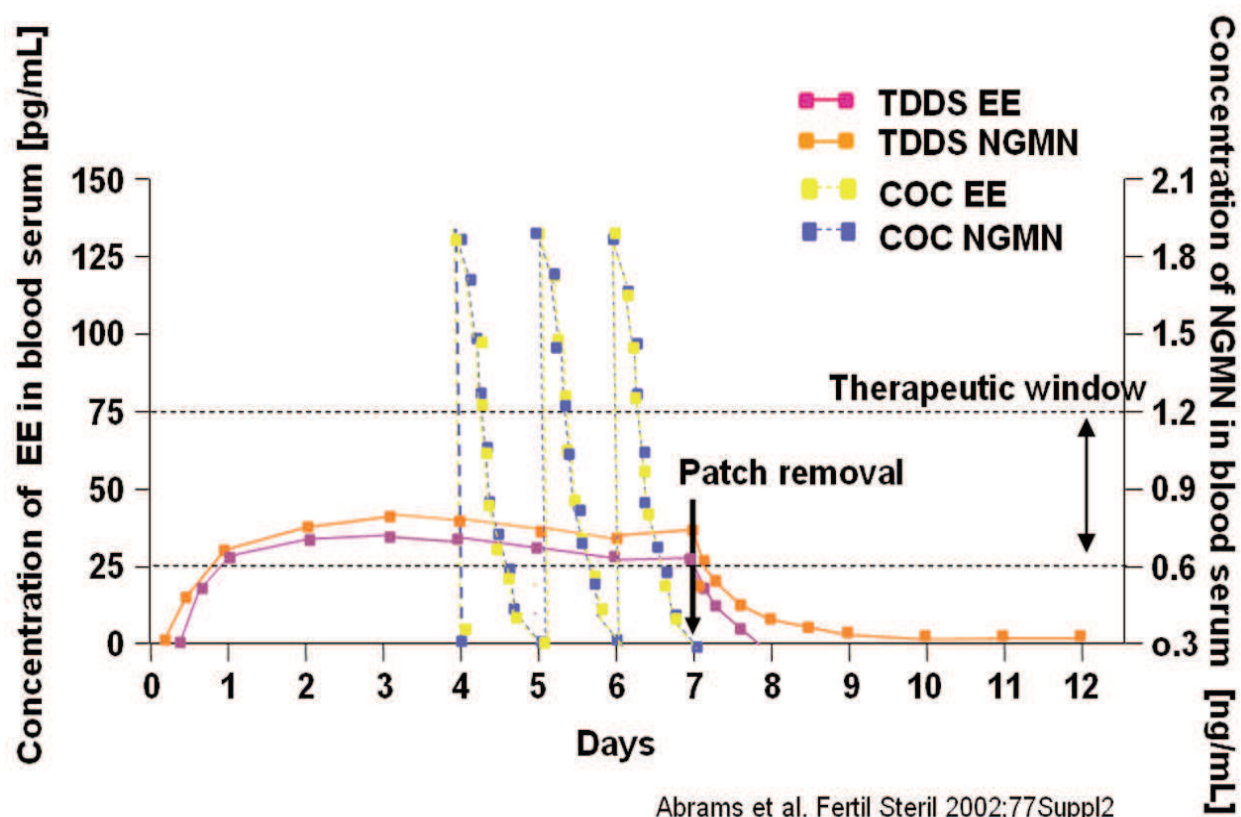

Fig. 10. Pharmacokinetics of hormonal contraception in relation to the way of administration. TDDS - transdermal delivery systems, COC - combined oral contraceptives, EE - ethinyl estradiol, NGMN - norelgestromin

In TDDS, effective levels of serum hormones are reached a day following patch application and maintained within the therapeutic window throughout the seven days of wear. When the patch is then removed on day 7, hormone levels decline, however are negligible only by day 10. This profile of steady levels of EE and NGMN throughout the seven days of patch-wear, stays in contrast to the daily peaks and troughs seen with a pill taken once a day. In pill users, the levels of hormones drop fast below the therapeutic level, which may lead to unintended pregnancy. This may not happen in TDDS users, who if make errors, usually forget to REPLACE the patch. In such situations, blood serum hormone levels are found to remain within the therapeutic window least two extra days. Sustained concentrations of EE and NGMN suggest that clinical efficacy can be maintained even if scheduled patch change is missed. This gives an extra time of two days of relative contraceptive safety, compared with 12 hours given by the pill.

Pressure-sensitive adhesives used for delivery systems are primarily based on acrylics, polyisobutylenes and silicones, although the most important role plays acrylics. Close cooperation between pharmaceutical and companies which produce PSAs is essential for the successful development of such systems, for example, has led to the development of permeation enhancers that temporarily modify the permeability of skin, allowing drugs with larger molecular structures to be considered for TDDS therapy.

One problem area requiring further work is the limited solubility of drugs in adhesives. The solubility of some drug molecules is less than 1 wt. % in polyisobutylenes and only slightly better in acrylics. The using of co-solvents allows solving this problem. To ensure the

finished product has adequate cohesive strength, high molecular weight adhesives with high shear resistance need to be used if non-volatile co-solvents are blended in to reach the necessary drug solubility levels.

Another difficulty is that dispersions adhesives cannot easily be used in TDDS applications because they tend to re-emulsify when exposed to perspiration. Transdermal patches are increasingly worn over several days, so that the adhesion must be maintained in the presence of wet skin. For this reason transdermals have had to rely on solvent-based and low-temperature hot-melt adhesives.

2.3.3 OP-tapes

An interesting application of acrylic pressure-sensitive adhesives medical grade is for securing sheets and other covering materials used in hospital operation theatres. The special composition of the acrylic water-soluble PSAs allows such pressure-sensitive adhesive tapes to be used even on hydrophobic, low surface energy cotton cloths coated with polyfluorocarbon resins. The acrylic adhesives used for securing operation theatre linen must be largely moisture-resistant, insoluble in cold water and must have a removable adhesion to the skin as well as hypoallergenic properties. The target in this case is a complete water-solubility of the adhesive, and thus a complete dispersibility of the OP-tape, is reached above 60 to 70°C and in the pH range (pH > 9). For this application, the availability of water-soluble carrier materials is also demanded.

Due to the growing environmental problems, reusable operation theatre linen is becoming increasingly important throughout Europe. The number of hospitals which employ reusable linen is rising continuously. The market for reusable medical systems of this kind is expanding very rapidly. The textile materials with polyfluorocarbon resins are used with OP-tapes especially developed for the medical sector and fixed after steam sterilisation for 20 min at 121°C on the skin of the patient. After use, the operation-tape is removed without residue during the washing process (pH range > 9 at 65°C) from the textile, the pressure-sensitive adhesive is dissolved and the carrier completely dispersed.

In view of the current situation regarding disposal of hospital waste, top priority must be given to waste prevention. Therefore, products which can be reused several times are of fundamental importance, especially textiles because, by their nature, they are designed for long-term use. A double-sided medical tape is applied to the textile sheets, which are then be secured to the patient's skin. The quality of such tapes must be such that they have sufficient adhesion during use but can be removed completely from the textile cotton cloths after use, i.e., during washing (Fig. 11).

2.3.4 Biomedical electrodes

The term "biomedical electrode" as used here means an electrode for establishing an electrical connection between the skin of a living body and an electromedical apparatus.

Scientists have conducted their own developments, which is based on water-soluble, ionically conductive pressure-sensitive adhesives. The adhesive used in layers allows important biological processes to be stimulated by bioelectrical signals. The outstanding features of such adhesive electrodes are their resistance to skin moisture, resistance to drying out, and their safe use on the skin.

Many biomedical electrodes are known in the art, they use electro-conductive materials such as conductive creams, pastes, and gels that incorporate natural polymers such as karaya

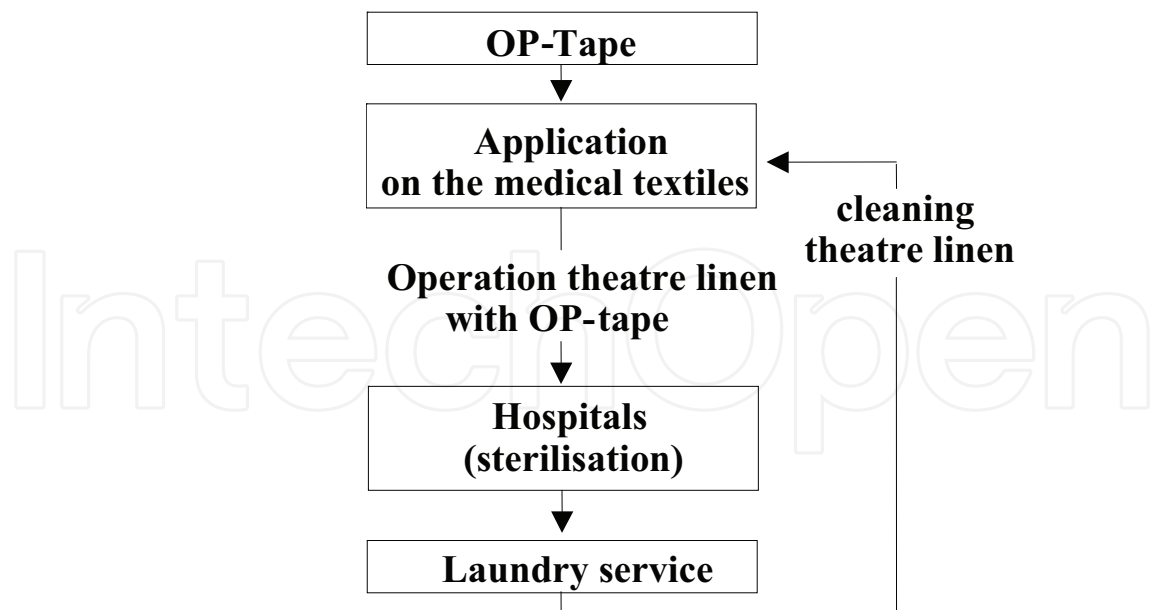

Fig. 11. Recycling of reusable operation theatre linen

gum, so as to provide good contact between the skin surface and the electrode and reduce electrical resistance across the skin-electrode interface. Such conductive materials are placed between the skin and the electrode plate so as to ensure good electrical connection of the skin surface to biomedical diagnostic equipment such as high-impedance electro-myographs and electrocardiographs. Conductive creams and pastes are unpleasant to use, are sloppy and will often foul the skin surface. Adhesion to the skin must be adjustable within a certain range and removal of the electrodes must be gentle and should cause no discomfort.

The following kinds of large-area biomedical electrodes are used:

TENS (Transcutaneous Electrical Nerve Stimulation) electrode coupling media is produced from low to medium concentration of sodium chloride in the hydrogel sheets.

ESU (Electro-Surgical Unit) electrode is produced from a low ionic hydrogel sheet.

EKG (electrocardiogram) electrodes are the poly(ethylene oxide) hydrogel-based electrodes. They have a variety of specific use applications, made possible by the ability to produce hydrogels of specific ionic strengths.

DEFIBRILLATION pad. The defibrillator pad is produced from a sheet containing conductive ions. The pad is usually used as a conductive medium for the application of large amounts of electricity (voltage and current) and also is used as a sensing electrolyte for EKG monitoring through the same electrodes.

BIO-FEEDBACK electrodes. Bio-Feedback electrodes are produced from a high ionic concentration gel sheet. They are used with a wide variety of clinical electrodes, and permits immediate signal reception.

New biomedical electrodes (Fig. 12) consist of an electrically conductive foil (1), a contact (2) and an electrically conductive pressure-sensitive adhesive (3), which is applied over the surface of the electrically conductive foil.

Biomedical electrodes are applied in the following medical areas:

- stimulation of biological processes
- percutaneous administration of medicines
- discharge of currents from surgical high-frequency cutting instruments

- pain relief by means of appropriate electrical signals
- monitoring the patient's state of health in the intensive care and as well as in the operation theatre

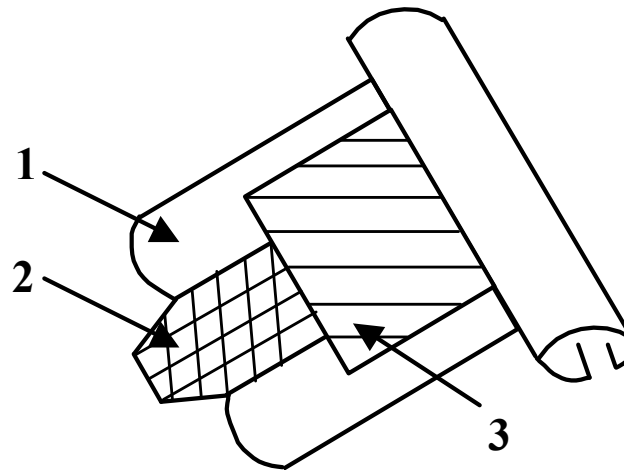

Fig. 12. Design of a new biomedical electrode

New biomedical electrodes have a transparent, electrically conductive, highly elastic and hypoallergenic layer of pressure-sensitive adhesive based on acrylic, silicone or poly(vinyl pyrrolidone) (PVP). The gentle adhesion of the hydrophilic layer to the skin is not impaired by the skin moisture or sweat. Principally, both the adhesive and cohesive strengths of the electrically conductive adhesive layer are also sufficient to ensure that the electrodes remain fully functional throughout the prescribed duration of application. The acrylic adhesive layers, which crosslink at room temperature, contain a soft resin, a (poly)electrolyte and a moisturiser.

Biomedical electrodes are monitored constantly with respect to electrical conductivity and resistance to skin moisture and drying out. In addition, the electrically conductive adhesive layers are tested for their hypoallergenicity and resistance to ageing. As confirmed by trials with biomedical electrodes, the newly developed biological electrodes have outstanding resistance to skin moisture and retain their most important properties, such as electrical conductivity and resistance to drying out during storage.

2.3.5 Self-adhesive hydrogels

Self-adhesive hydrogels are three-dimensional hydrophilic water-swallowable polymeric materials in form of polymeric films characterized in dry and in water-swollen state by tack, peel adhesion and shear strength. They are crosslinked polymeric structures containing either covalent bonds produced by the simple reaction of one or more comonomers, chemically crosslinked using conventional at room temperature reactive crosslinking agents, thermal reactive crosslinkers or crosslinked by the use of UV radiation in the area between 200 and 400 nm. The hydrogen bonds, based on a dipole-dipole attraction of polar groups such as $-\text{COOH}$, $-\text{CONH}_2$ or $-\text{OH}$ and association bonds such as van der Waals forces between polymer chains are not enough strong for excellent structure of hydrogels. Hydrogen bonds are fully reversible and three to four times as strong as van der Waals forces. Consequently PSAs with H-bonds are significantly stronger than those, which are

interconnected only by van der Waals forces. Secondary valence crosslinkings are in general distinguished from primary valence crosslinkings by their thermoreversible nature. When warmed up the crosslinking is lost and during cooling it is formed again.

The physical behavior of hydrogels is dependent on their equilibrium and dynamic swelling behavior in water, since upon preparation they must be brought in contact with water to yield the final, swollen network structure. Hydrogels are a unique class of macromolecular networks that may contain a large fraction of aqueous solvent within their structure. The hydrophilic-hydrophobic balance of the hydrogels, the degree of crosslinking, and especially, the degree of ionization and its interaction with counterions are the important parameters which control the equilibrium swelling, dimensional change and the release patterns of drugs from these carriers. Hence, mathematical modeling of hydrogel swelling and predictability of swelling behavior has gained considerable attention during past decades. The favorable property of hydrogels is their ability to swell, when put in contact with a thermodynamically compatible solvent, in this case water. When a hydrogel in its initial state is in contact with water molecules, the latter attacks the hydrogel surface and penetrates into the polymeric network. In this case, the unsolvated glassy phase is separated from rubbery hydrogel region with a moving boundary. Regularly the meshes of the network in the rubbery phase will start expanding, allowing other water molecules to penetrate within the hydrogel network.

Self-adhesive hydrogels are characterized by permanent adhesiveness performance before, during and after water absorption (Fig. 13). They are characterized by fast swelling, excellent mechanical properties, and high transparency after water absorption and good elastic properties. In the lab of Westpomeranian University of Technology in Szczecin has been developed a new generation of self-adhesive hydrogels based on acrylic polymers.

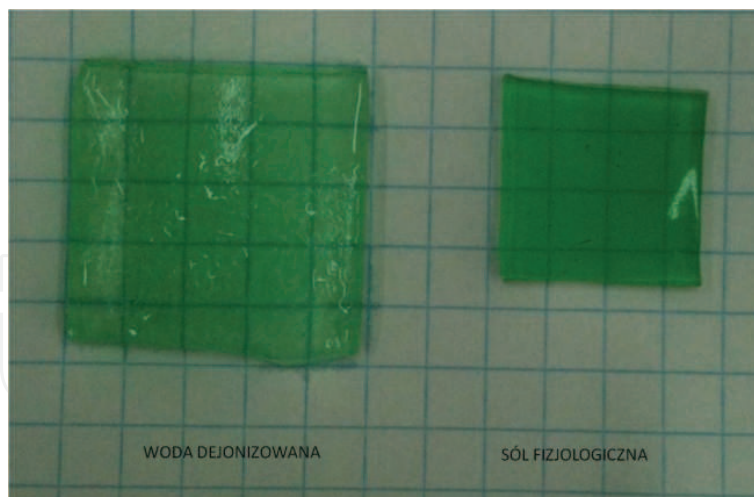

Fig. 13. Medical self-adhesive hydrogel after (right) and before (left) absorption of water

The physical properties of self-adhesive hydrogels make them attractive for a variety of technical, biomedical and pharmaceutical applications. The applications of hydrogels are grown extensively. They are currently used as scaffolds in tissue engineering where they may contain human cells in order to repair tissue. Environmental sensitive hydrogels have the ability to sense environmental stimuli, such as changes of pH, temperature, or the concentration of metabolite and then release their load as a result of such a change. Self-

adhesive hydrogels can be used as biosensors as well as in drug delivery systems (DDS). These kinds of hydrogels are also used as controlled-release delivery devices for bioactive agents and agrochemicals. Contact lenses are also based on hydrogels. Hydrogels are formulated to absorb moisture resulting in a skin compatible system as well. The absorption of trans epidermal water (TEW) can enhance the wetting and the adhesion on the skin of these adhesive systems, resulting in a gradual increasing adhesion during water. The acceptance of moist wound healing as being most appropriate for rapid healing has led to the further development of hydrogels in occlusive dressings capable of maintaining the correct wound environment. Hydrogels are very suitable in achieving a balance between exudates handling and maintaining a moist environment. The absorption capacity of these adhesive systems is measured by fluid handling capacity in g/m²h. This intrinsic property of hydrogels allows them to be introduced in medical tapes suitable for damaged and even enhancing the skin healing process.

2.3.6 Surgical drapes

Medical surgical drapes are carrier-based products, which are generally manufactured by adhesive coating. Because of the absorption, dosage, and storage function of such tapes, they are coated on special porous carrier materials with high coating weight of special acrylic adhesives. These adhesives do not contain volatiles. Acrylic pressure-sensitive adhesives in medical drapes may display adhesion buildup in the time, or weakening of the cohesive strength due to migration of oils. These disadvantages are avoided by crosslinking with built-in special monomers or special crosslinking agents. Surgical drapes as medical products allow using of diverse raw materials in form of hotmelts acrylic PSAs, UV-crosslinked acrylic prepolymer, solvent-borne acrylic PSAs and other non acrylic polymers. Commercial acrylic PSAs used for skin application are easier to remove and cause less skin irritation than other kinds of adhesives. Acrylic adhesive compositions for medical surgical drapes which do not leave adhesive residues on skin contain modified copolymers having a molecular weight of 2500 to 3000 dalton. Cotton cloth and hydrophobic textile materials coated with low energy polyfluorocarbon resins are used as carrier materials for surgical tapes. Because the skin is part of the systemic and immune system, medical surgical drapes require testing to indicate the suitability on human skin. As part of medical devices, medical tapes are tested in accordance with FDA guidance and ISO 10993 standards. The safety evaluation involves advanced biocompatibility testing appropriate to the intended use of the component material. Medical surgical drapes applied on healthy skin are categorized as skin surface devices and tested on skin irritation and sensitization as detailed in the ISO guidelines.

3. References

- [1] D. Satas, "Handbook of Pressure Sensitive Technology", Van Nostrand-Rheinhold Co, New York, USA (1982)
- [2] Z. Czech, Crosslinking of Pressure-Sensitive Adhesives based on acrylics, Szczecin University of Technology, Szczecin (1999)
- [3] I. Benedek, Developments in Pressure-Sensitive Products, Taylor & Francis a CRC Press Book, New York (2006)

- [4] Z. Czech, R. Kurzawa, "Acrylic Pressure-Sensitive Adhesives for Transdermal Drug Delivery Systems", *Journal of Applied Polymer Science* 106 (2007) 2398-2404
- [5] Z. Czech, A. Wróblewska, E. Meissner, R. Kurzawa, "Pressure-Sensitive Adhesives for Transdermal Drug Delivery Systems", *Conference*, SURUZ 2007, (2007) 443-446

IntechOpen

IntechOpen



Wide Spectra of Quality Control

Edited by Dr. Isin Akyar

ISBN 978-953-307-683-6

Hard cover, 532 pages

Publisher InTech

Published online 07, July, 2011

Published in print edition July, 2011

Quality control is a standard which certainly has become a style of living. With the improvement of technology every day, we meet new and complicated devices and methods in different fields. Quality control explains the directed use of testing to measure the achievement of a specific standard. It is the process, procedures and authority used to accept or reject all components, drug product containers, closures, in-process materials, packaging material, labeling and drug products, and the authority to review production records to assure that no errors have occurred. The quality which is supposed to be achieved is not a concept which can be controlled by easy, numerical or other means, but it is the control over the intrinsic quality of a test facility and its studies. The aim of this book is to share useful and practical knowledge about quality control in several fields with the people who want to improve their knowledge.

How to reference

In order to correctly reference this scholarly work, feel free to copy and paste the following:

Zbigniew Czech and Agnieszka Kowalczyk (2011). Pressure-Sensitive Adhesives for Medical Applications, Wide Spectra of Quality Control, Dr. Isin Akyar (Ed.), ISBN: 978-953-307-683-6, InTech, Available from: <http://www.intechopen.com/books/wide-spectra-of-quality-control/pressure-sensitive-adhesives-for-medical-applications>

INTECH
open science | open minds

InTech Europe

University Campus STeP Ri
Slavka Krautzeka 83/A
51000 Rijeka, Croatia
Phone: +385 (51) 770 447
Fax: +385 (51) 686 166
www.intechopen.com

InTech China

Unit 405, Office Block, Hotel Equatorial Shanghai
No.65, Yan An Road (West), Shanghai, 200040, China
中国上海市延安西路65号上海国际贵都大饭店办公楼405单元
Phone: +86-21-62489820
Fax: +86-21-62489821

© 2011 The Author(s). Licensee IntechOpen. This is an open access article distributed under the terms of the [Creative Commons Attribution 3.0 License](#), which permits unrestricted use, distribution, and reproduction in any medium, provided the original work is properly cited.

IntechOpen

IntechOpen