

We are IntechOpen, the world's leading publisher of Open Access books Built by scientists, for scientists

4,800

Open access books available

122,000

International authors and editors

135M

Downloads

Our authors are among the

154

Countries delivered to

TOP 1%

most cited scientists

12.2%

Contributors from top 500 universities



WEB OF SCIENCE™

Selection of our books indexed in the Book Citation Index
in Web of Science™ Core Collection (BKCI)

Interested in publishing with us?
Contact book.department@intechopen.com

Numbers displayed above are based on latest data collected.

For more information visit www.intechopen.com



p53, p63 and p73 Network in Breast Cancers

Chee-Onn Leong
International Medical University,
Malaysia

1. Introduction

Inactivation of the tumor suppressor p53 is the single most common genetic defect in all human cancers. The p53 tumor suppressor is critically important in regulation of cell cycle progression, senescence, differentiation, DNA repair and apoptosis. The discovery of two closely related homologues, p63 and p73, in 1997 generated instant excitement and quick expectations about their tumor suppressor functions. However, despite a remarkable structural and partial functional similarity among p53, initial p63 and p73 mouse knockout studies revealed an unexpected functional diversity among them. p63 and p73 knockouts exhibit severe developmental abnormalities but no increased cancer susceptibility. While p53 is frequently mutated during tumorigenesis (in over 50% of human tumors), p63 and p73 are rarely mutated. Instead, the p63 locus is amplified in squamous cell carcinomas (Bjorkqvist et al., 1998; Massion et al., 2003) and p73 is overexpressed in many tumor types including breast cancers (Moll and Slade, 2004; Zaika and El-Rifai, 2006; Zaika et al., 1999). Although p63 and p73 can activate apoptosis *in vitro*, it is clear that they are not classic Knudson-like tumor suppressors like p53.

Throughout the years, impressive number of evidences has been uncovered, suggesting that the p53-family play an important role in breast cancers. The emerging picture is that of an interconnected pathway, in which all p53-family proteins are involved in the response to oncogenic stress and physiological inputs. The p53/p63/p73 family members are capable of interacting in many ways that involve direct or indirect protein interactions, regulation of same target gene promoter and regulation of each other's promoters. As such, fluctuations in the levels of selected p53 family members (or their isoforms) might change the relative availability of shared protein partners, as multiple p53-family proteins compete for interaction. Also, differential expression of selected interactors - linked with genetic variation - may distinguish the response of the p53 pathway to the same potentially oncogenic stimuli in diverse individuals.

Despite the recent advances in understanding the unique roles of p53 family protein in breast cancers, there are many outstanding questions. What are the unique functions of the TA and ΔN isoforms of p63 and p73? How is individual p53 family member mediates gene expression regulated by the interaction with mutant p53 and other family member and their splicing variants in the cell? What are the patterns of p53 family isoform expression during normal development and tumorigenesis? What are the upstream signaling pathways that regulate individual p53 family member? What are the p53, p63 and p73 target genes? Do p53, p63 and p73 regulate distinct and/or overlapping sets of genes? Understanding the

complexity of these interactions allow us to delineate the function of p53 family in human tumorigenesis and enable the development of new cancer therapeutics.

2. The origins and gene architecture of the p53 family proteins

The tumor suppressor gene, p53, was discovered in 1979 (Lane and Crawford, 1979; Linzer and Levine, 1979). Until recently, *p53* was thought to be a unique gene with no genetic paralogues. In 1997, however, Caput and coworkers serendipitously identified a human homolog of p53 which they called p73 (Irwin and Kaelin, 2001; Kaelin, 1999; Kaghad et al., 1997). Shortly thereafter, several groups identified a third member of the family variably called Ket, p40, p51, p73L and p63 (Irwin and Kaelin, 2001; Kaelin, 1999; Osada et al., 1998; Schmale and Bamberger, 1997; Senoo et al., 1998; Trink et al., 1998; Yang et al., 1998). While p53 was discovered first, evolutionary conservation of DNA sequence suggests that p63 arose first during evolution, then p73 and finally p53 (Johnson et al., 2005).

Like many transcription factors, p53 are modular proteins with a conserved N-terminal transcriptional activation domain (TA), central DNA-binding domain (DBD) and a C-terminal oligomerization domain (OD) (Fig. 1) (Arrowsmith, 1999). The DBD has the highest degree of homology, where p63 and p73 share 65% amino-acid identity with p53, and even higher identity with each other. All three genes express many spliced isoforms – a feature that was thought to be unique for p63 and p73 but has recently found to be true for p53.

The existence of an internal promoter within the p53 family was first discovered in *p63* (Yang et al., 1998). The human and mouse *p63* genes express at least three alternatively spliced C-terminal isoforms (α , β , γ), and can be transcribed from an alternative promoter located in the intron 3 (Fig. 1). The transactivating isoforms (TAp63) are generated using the promoter upstream of exon 1 while the alternative promoter in intron 3 leads to the expression of N-terminal truncated isoforms (Δ Np63) lacking the transactivation domain. Altogether, the *p63* gene expresses at least six mRNA variants which encode for six different p63 protein isoforms (TAp63 α , TAp63 β , TAp63 γ , Δ Np63 α , Δ Np63 β , and Δ Np63 γ) (Murray-Zmijewski et al., 2006).

The p73 gene expresses at least seven alternatively spliced C-terminal isoforms (α , β , γ , δ , ϵ , ζ and η) and at least four alternatively spliced N-terminal isoforms (Melino et al., 2003; Moll and Slade, 2004; Stiewe et al., 2002b). Like p63, the p73 gene can be transcribed from an alternative promoter located in the intron 3 (Fig. 1). The transactivating isoforms are generated by the activity of the promoter upstream of exon 1 while the alternative promoter in intron 3 leads to the expression of the N-terminal truncated isoforms (Δ Np73) lacking the transactivation domain. Altogether, the p73 gene expresses at least 35 mRNA variants, which can encode theoretically 29 different p73 protein isoforms (Fig. 1). So far, 14 different p73 protein isoforms have been described. In contrast to p63, p73 isoforms can be initiated from different ATG and contain different part of the N-terminal domain, suggesting that they can have distinct protein interactions and specific activities (Murray-Zmijewski et al., 2006).

3. Developmental phenotypes of p53, p63 and p73 knockout mice

Since p53 is a powerful tumor suppressor gene, its loss in mice predisposes the animals to cancers of various organs (involving tissues such as blood, muscle and bone) with no visible developmental defects. Similarly, human patients with Li Fraumeni syndrome, the disease

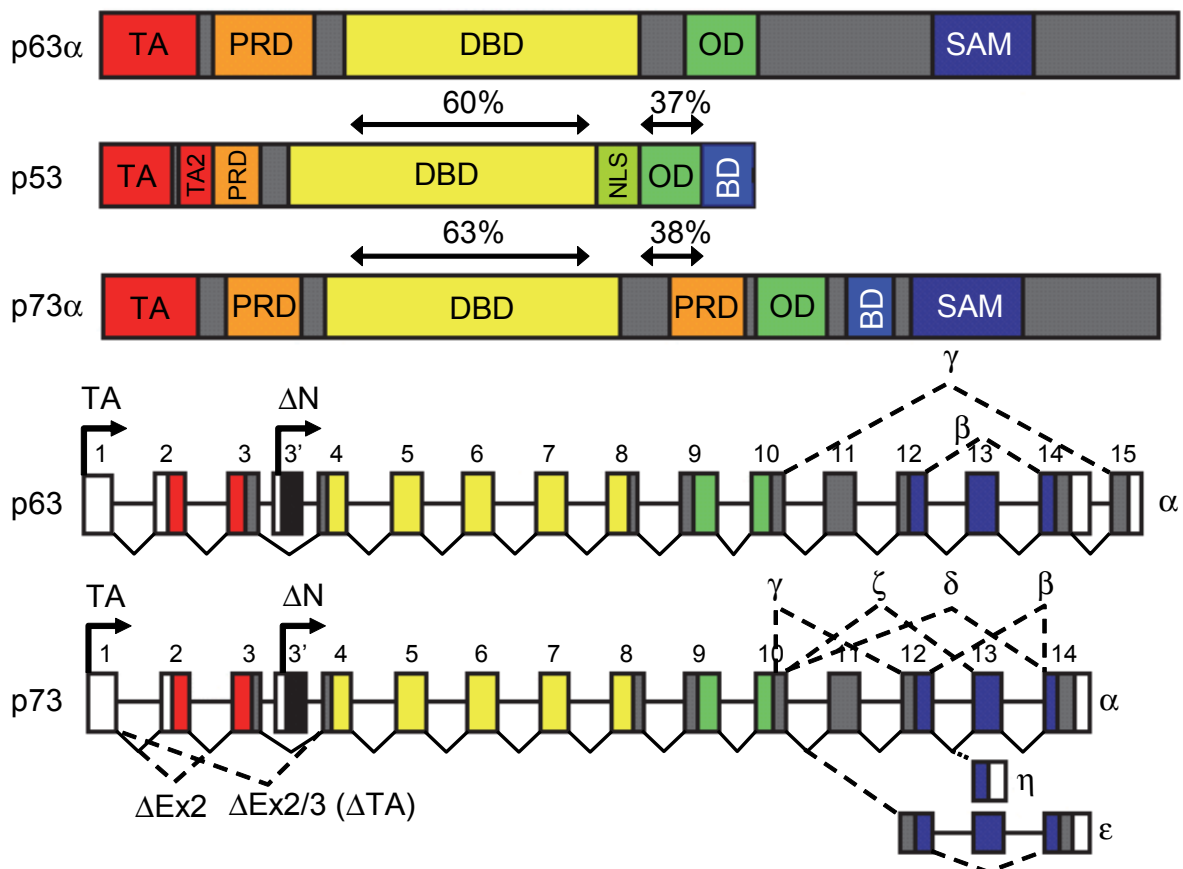

Fig. 1. **Gene architecture of the p53 family.** The p53 family includes the three genes p53, p63, and p73. Each of them has a modular structure consisting of the transactivation domain (TA), the DNA binding domain (DBD), and the oligomerization domain (OD). In addition to the 3 common domains, p63 and p73 also harbor a C-terminal sterile alpha-motif (SAM) domain in the α isoform. All p53 family genes are expressed as two major types: the full-length proteins containing the TA domain and ΔN proteins missing the TA domain. The P1 promoter in the 5'-untranslated region produces TA proteins that are transcriptionally active, whereas the P2 promoter produces ΔN proteins with dominant-negative functions toward themselves and toward wild-type p53. In addition, both p63 and p73 also undergo extensive C-terminal alternative splicing generating a myriad of isoforms with different transcriptional activity and specificity.

caused by germ line mutation of human p53, also predisposes to various cancer especially breast cancers (Johnson et al., 2005). While p53 seems to play little role in embryonic development, the p63 and p73 deficient mice have severe developmental abnormalities (Westfall and Pietsenpol, 2004).

3.1 p63 in development: Role in epithelial differentiation and proliferation

p63-deficient mice are born alive but the limbs are absent or truncated owing to a malfunction of the apical ectodermal ridge (Mills et al., 1999; Yang et al., 1999). They fail to develop a stratified epidermis and most epithelial tissues (for example, hair follicles, teeth, prostate, lacrimal and salivary glands, and mammary glands), and eventually die from dehydration within hours of birth (Stiewe, 2007). Reminiscent of the knockout phenotype in

mice, heterozygous germ line point mutations of p63 in humans also cause striking autosomal dominant developmental disorders including ectrodactyly-ectodermal dysplasia (EEC) (Celli et al., 1999), ankyloblepharon-ectodermal dysplasia clefting (Hay-Wells Syndrome) (Fomenkov et al., 2003), acro-dermato-ungual-lacrima-tooth (ADULT) syndrome (Duijf et al., 2002), limb-mammary syndrome (LMF) (van Bokhoven et al., 2001), Rapp-Hodgkin syndrome (Chan et al., 2005), and split hand-split foot malformation syndrome (Brunner et al., 2002; Johnson et al., 2005; van Bokhoven et al., 2001).

Although the p63-deficient mice and human cases showed prominent phenotypes, the actual function of p63 in developmental processes remain controversial. The two groups that generated the p63-deficient mice reported identical phenotypes, the conclusions drawn from examination of the murine tissues differed (Westfall and Pietenpol, 2004). In one case clumps of differentiated cells were detected in the epidermis (Yang et al., 1999), whereas in the other, uncommitted ectodermal cells covered the body surface (Mills et al., 1999). This led to two divergent points of view emerged from these analyses: one group attributed the p63-null phenotype to an absence of lineage commitment and an early block in epithelial differentiation (Mills et al., 1999); the other postulated that the phenotype was secondary to a defect in epithelial stem-cell renewal (Yang et al., 1999). It thus remained uncertain whether the primary function of p63 was in control of differentiation or self-renewal, or both (Blanpain and Fuchs, 2007).

Subsequent studies on p63 attempted to clarify this issue, but were further complicated with the discovery that the two principal isoforms of p63, $\Delta Np63$ and TAp63, each of which have distinct roles in epithelial development. When transgenic mice expressing either TAp63 and/or $\Delta Np63$ were bred on the p63-null background, mice expressing $\Delta Np63$, but not TAp63, partially rescued basal epidermal gene expression, whereas only mice coexpressing both isoforms presented a significant improvement in expression of terminal differentiation marker. This data is consistent with the notion that $\Delta Np63$ governs basal-epidermal gene expression, whereas TAp63 (possibly together with $\Delta Np63$) promote terminal differentiation. Taken together, these studies supported a role for p63 in differentiation and not self-renewal. However, a later study by Senoo et al. (2007) demonstrated that p63 is not required for lineage commitment and differentiation of epithelial cells, as these cells present the typical markers for epithelial development and, in the case of the thymic epithelia, are fully competent to support the maturation of developing T cells in the thymus (Senoo et al., 2007). The study provides compelling evidence that p63 functions specifically to maintain the extraordinary proliferative capacity of the epithelial stem cells of the thymus and epidermis, suggesting a general function of the p63 transcription factor in maintaining the stem cells of a broad array of stratified epithelia. Thus, the question whether p63 functions in control of differentiation, self-renewal, or both remain debatable.

3.2 p73 in development: Role in neuronal and pheromonal pathways

The p73 knock-out mice have profound developmental defects including hippocampal dysgenesis, hydrocephalus, chronic infections and inflammation (Abraham and Meyer, 2003). They also exhibit abnormal reproductive and social behavior due to defects in pheromone detection, attributed to a dysfunctional nasal organ that normally expresses high levels of p73 (Johnson et al., 2005). The tissue specificity of the p73 deficient phenotype (concentrated to the brain and related structures) may be associated with variable patterns of isoforms expressed in brain vs. other tissues (Hu et al., 2000; Johnson et al., 2005).

Δ Np73 is the predominant isoform in the developing mouse brain and might act as a transcriptional repressor (Pozniak et al., 2000; Yang et al., 1998). *In situ* hybridization reveals strong Δ Np73 expression in E12.5 fetal mouse brain in the preplate layer, bed nucleus of stria terminalis, choroid plexus, vomeronasal area, and preoptic area (Yang et al., 2000). Moreover, Δ Np73 is the only form of p73 found in mouse brain and the sympathetic superior cervical ganglia in P10 neonatal mice (Pozniak et al., 2000). Functional studies and knockout mice showed Δ Np73 is required to counteract p53-mediated neuronal death during the normal development of the mouse neuronal system (Pozniak et al., 2000). Withdrawal of nerve growth factor, an obligate survival factor for mouse sympathetic neurons, leads to p53 induction and p53-dependent cell death. In pull-down assays, mixed protein complexes of p53/ Δ Np73 were demonstrated, suggesting one biochemical basis for transdominance in addition to possible promoter competition. Together, these data demonstrated that Δ Np73 is downstream of nerve growth factor in the nerve growth factor survival pathway and explains why p73-deficient mice, missing all forms of p73 including protective Δ Np73, undergo accelerated neuronal death in postnatal superior cervical ganglia (Moll and Slade, 2004; Pozniak et al., 2000).

To date, there are no human developmental syndromes associated with germ line p73 mutations (Johnson et al., 2005). Unlike p53-deficiency, p73 knock-out mice show no increased susceptibility to spontaneous tumorigenesis (Stiewe and Putzer, 2002; Yang et al., 2000).

4. Role of p53 family in breast malignancy: Tumor suppressor or oncogene?

p53 is a powerful tumor suppressor, as proven by a wealth of *in vivo* models and dramatically confirmed by frequent mutation in human cancers. However, the role of p63 and p73 in tumor suppression is less obvious, because they are rarely deleted or mutated in cancer and the respective homozygous knockout mice die tumor-free from developmental defects in the initial studies.

4.1 p63 and cancer

p63, mainly its Δ N isoform, is highly expressed in embryonic epidermis and act as a molecular switch for initiation of an epithelial stratification program (Koster et al., 2004). In postnatal epidermis, Δ Np63 expression is restricted to the nuclei of basal cells of normal epithelia (skin, esophagus, tonsil, prostate, urothelium, ectocervix, and vagina) and to certain populations of basal cells in glandular structures of prostate, breast, and bronchi (Di Como et al., 2002; Yang et al., 1998). Specifically, p63 is expressed in myoepithelial cells of the breast that play an important role in differentiation and carcinogenesis of the breast (Davis et al., 2002; Garraway et al., 2003; Moll and Slade, 2004; Reis-Filho et al., 2003a; Ribeiro-Silva et al., 2003). p63 expression was not detected in mesenchymal, neural, endothelial, smooth muscle or adipose cells consistent with restricted p63 expression in squamous and basal epithelial tissues (Reis-Filho et al., 2003b; Westfall and Pietenpol, 2004). The initial findings showed that Δ Np63 α can act antagonistically toward p53 (Yang et al., 1998). Subsequent studies found dysregulated expression of p63, sometimes in conjunction with amplification of its genomic region at 3q27-28 in many human epithelial cancers (Crook et al., 2000; Hibi et al., 2000; Massion et al., 2003; Park et al., 2000; Yamaguchi et al., 2000). Amplification of the p63 gene frequently leads to overexpression of the Δ Np63 α .

variant (Hibi et al., 2000). Regardless, $\Delta Np63\alpha$ have been reported to be frequently overexpressed in bladder, breast, cervix, head and neck, lung, prostate and nasopharyngeal carcinoma (Crook et al., 2000; Moll and Slade, 2004; Westfall and Pietenpol, 2004). Overexpression of the $\Delta Np63$ variant in Rat 1a cells have also been shown to increase growth of these cells in soft agar and as xenograft tumors (Hibi et al., 2000). Thus, the maintenance of the $\Delta Np63$ isoforms in squamous cancers may contribute to keeping the cells in a stem cell-like phenotype, thereby promoting tumor growth. Of note, analysis of p63 sequence isolated from various human tumors and numerous human cancer cell lines showed that p63 rarely, if ever, mutated (Hagiwara et al., 1999; Osada et al., 1998). Collectively these data suggest that p63 does not function as a tumor suppressor but rather as an oncogene (Westfall and Pietenpol, 2004).

Nevertheless, studies on the TA isoform of p63 suggest an opposite view. Transient transfection of TAp63 has been shown to induce cell cycle arrest and apoptosis (Osada et al., 1998; Westfall and Pietenpol, 2004; Yang et al., 1998). The TAp63 isoforms are able to bind to DNA through p53 response element (p53RE) and activate transcription of a subset of p53 target genes (Murray-Zmijewski et al., 2006). Interestingly, TAp63 γ had the greatest transactivation activity and TAp63 α had the minimal activity (Westfall and Pietenpol, 2004). The $\Delta Np63$ isoforms can also bind DNA through p53RE and can exert dominant-negative effects over p53, p73 and p63 activities by either competing for DNA binding sites or by direct protein interaction (Benard et al., 2003). Moreover, $\Delta Np63$ isoforms were also shown to directly activate specific gene targets not induced by TA isoforms (Dohn et al., 2001; Wu et al., 2003). Thus, p63 has the ability to regulate a number of genes with diverse roles and possesses opposing regulatory effect by expressing different amount of TAp63 and $\Delta Np63$ isoforms. Thus, an abnormal alteration in expression of these isoforms is likely to play an important role in tumorigenesis.

4.2 p73 and cancer

Like p63, p73 is rarely, if ever mutated in cancers. Unlike p63 which is frequently amplified in epithelial cancers, p73 frequently undergoes loss of heterozygosity in breast and colon cancer, neuroblastoma, oligodendroglioma, and melanoma. This fact, in conjunction with the functional similarity to p53, originally led to the proposal that p73 is a tumor suppressor gene (Kaghad et al., 1997). Genetic data on most cancer types, however, exclude p73 as a classic Knudson-type tumor suppressor, which by definition is targeted to undergo loss of expression or function during tumorigenesis. To date, loss of function mutations in p73 are vanishingly rare (0.6%). Moreover, imprinting of the p73 locus, initially thought to be an epigenetic explanation to satisfy the two-hit hypothesis, is rather uncommon and, if present, varies from tissue to tissue and person to person and does not correlate with p73 expression levels (Kovalev et al., 1998; Moll and Slade, 2004; Nomoto et al., 1998; Tsao et al., 1999; Zaika et al., 1999).

In fact, TAp73 overexpression has been found in different tumor types including tumors of breast (Leong et al., 2007; Zaika et al., 1999), neuroblastoma (Kovalev et al., 1998), lung (Mai et al., 1998; Tokuchi et al., 1999), esophagus (Cai et al., 2000), stomach (Kang et al., 2000), colon (Sunahara et al., 1998), bladder (Chi et al., 1999; Yokomizo et al., 1999), ovarian cancer (Chen et al., 2000; Ng et al., 2000; Zwahlen et al., 2000), liver cancer (Tannapfel et al., 1999b), cholangiocellular carcinoma (Tannapfel et al., 1999a), colon carcinoma (Sun, 2002), and head and neck squamous carcinoma (Choi et al., 2002; Rocco et al., 2006; Weber et al., 2002). Of

note, primary tumors and tumor cell lines with p73 overexpression tend to simultaneously overexpress a complex profile of shorter C-terminal splice variants (p73 γ , p73 δ , p73 δ , and p73 ϕ), whereas the normal tissue of origin is limited to the expression of p73 α and p73 β (Zaika et al., 1999). Importantly, patients with high global p73 protein expression had a worse survival than patients with undetectable levels (Moll and Slade, 2004; Sun, 2002; Tannapfel et al., 1999b).

Little is known about which genes are regulated specifically by p73 under physiological conditions. When overexpressed p73 also binds to p53 DNA target sites, transactivates p53-responsive genes and is capable of inducing cell cycle arrest and apoptosis in mammalian cells in a p53-like manner (Jost et al., 1997; Kaghad et al., 1997; Stiewe and Putzer, 2002). For example, p73 can activate the promoters of several p53-responsive genes, including *p21*, *BAX*, *PUMA*, *MDM2*, *GADD45*, *14-3-3 σ* , *cyclin G*, *IGFBP3*, and *p53R2* (Irwin and Kaelin, 2001; Jost et al., 1997; Kaghad et al., 1997; Lee and La Thangue, 1999; Nakano et al., 2000; Ueda et al., 1999; Vikhanskaya et al., 2001; Yang et al., 1998; Yu et al., 1999; Zhu et al., 1998). Nonetheless, there is evidence that p73 can activate many other genes which are not p53 target genes. For example, aquaporin 3 (AQP3), a glycerol and water transporter, has been shown to be a specific p73-responsive gene. It is speculated, that in p73-deficient mice lack of AQP3 induction accounts for the defects in production or reabsorption of cerebrospinal fluid, resulting in hydrocephalus (Stiewe and Putzer, 2002; Zheng and Chen, 2001).

Numerous reports also indicating a quantitative difference in the transcriptional activity of the various p73 splice variants. For example, the TAp73 β is a more potent transcriptional activator than TAp73 α (De Laurenzi et al., 1998; Lee and La Thangue, 1999; Yu et al., 1999; Zhu et al., 1998). Likewise TAp73 β is more potent than TAp73 α as an inducer of apoptosis, suggesting that TAp73 α contains an 'inhibitory' region not included in the β -isoform. Consistently, a C-terminal deletion mutant of TAp73 α lacking the putative inhibitory region showed a significantly higher level of transcriptional activity than wild-type TAp73 α (Ozaki et al., 1999; Ueda et al., 2001). Moreover, the transcriptional activity of TAp73 β was reduced *in trans* by co-expression with either TAp73 α or p73 ϵ , which bears an identical C-terminal structure as TAp73 α (Ueda et al., 2001). This suppression effect is most likely mediated by inter-variant associations as it depends on the presence of the oligomerization domain. These observations indicate that p73-mediated gene expression is regulated by the interaction of all p73 isoforms present in the cell. The current data therefore indicate the existence of transcriptional specificity among the p53-family members with pronounced differences between p53 and p73 on the one hand and between the various p73 isoforms on the other hand (Stiewe and Putzer, 2002).

5. Regulation of p53 family functions

The p53 family proteins are entangled in a regulatory network with positive or negative modulators. Many regulatory pathways may be shared by multiple p53-family proteins, with similar or different effects (Fig. 2).

5.1 Upstream regulation of p53 family members

One of the clear differences that discriminate p53 family members is the fact that they response to viral oncoproteins differently. Adenovirus E1B55, human papilloma virus E6 protein, and SV40 T antigen bind to and inactivate p53 during viral transformation (Fig. 2)

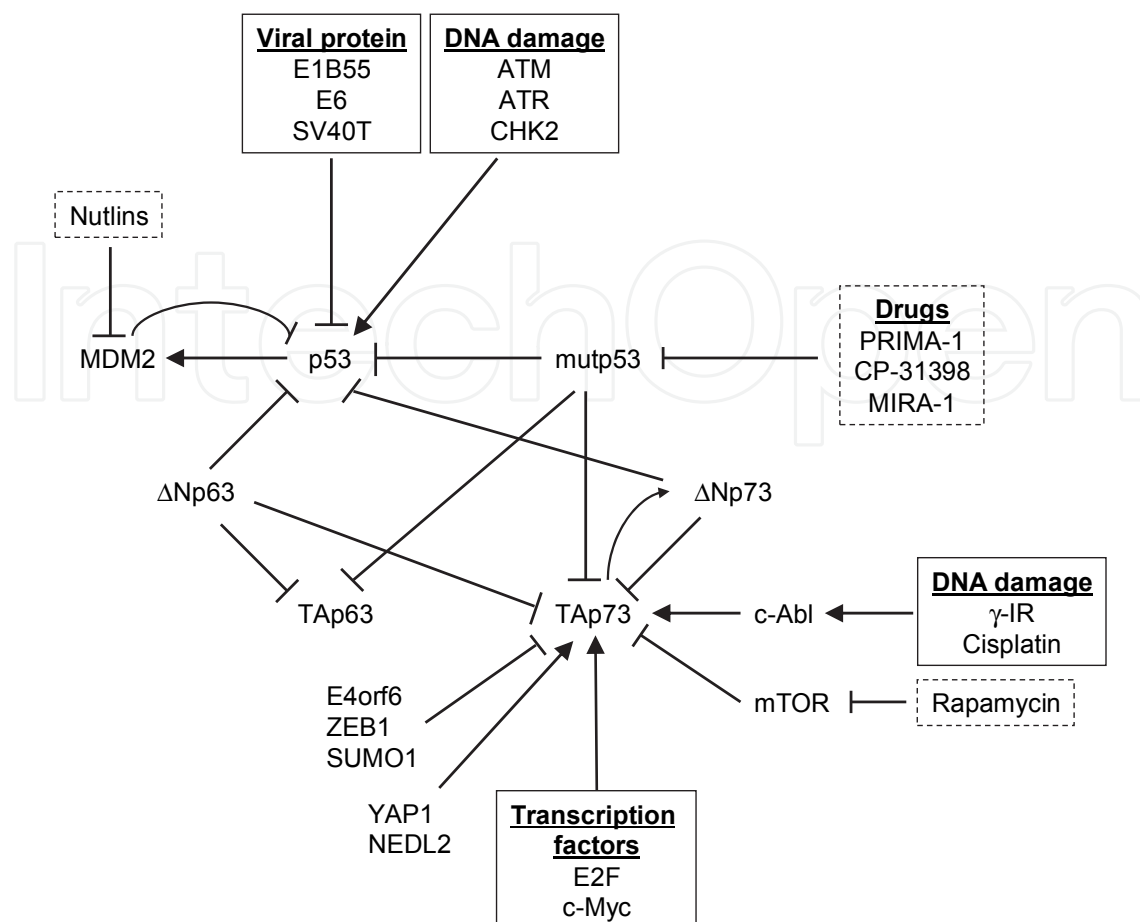

Fig. 2. The p53 family network and its regulation.

(Lechner et al., 1992; Linzer and Levine, 1979; Sarnow et al., 1982; Yew and Berk, 1992). These three proteins, however, do not bind to p73 (Dobbelstein and Roth, 1998; Marin et al., 1998; Roth et al., 1998; Steegenga et al., 1999). In fact, p73 β can induce growth inhibition and apoptosis in cancer cells that produce E6 (Prabhu et al., 1998). Likewise, E6 and SV40 T antigen do not interact with p63 (Roth and Dobbelstein, 1999). The adenoviral protein E4orf6 also binds to and antagonizes p53, but there have been conflicting reports as to whether it interacts with p73. Roth *et al.* (1998) reported that E4orf6 does not affect p73 stability or the ability of p73 to activate transcription (Roth et al., 1998). Two other groups reported that E4orf6 binds to the C-terminus of p73 and blocks transcriptional activation and colony suppression by p73 (Higashino et al., 1998; Steegenga et al., 1999). Thus, certain viral oncoproteins preferentially inactivate p53 while sparing p63 and p73, despite the high degree of similarity between these three proteins (Fig. 2).

Several reports have shown that the cellular oncogenes E2F1 and c-Myc can induce and activate the endogenous TAp73 α and TAp73 β proteins for target gene transactivation, apoptosis, and growth suppression in p53-deficient human tumor cells (Irwin et al., 2000; Lissy et al., 2000; Stiewe and Putzer, 2000; Zaika et al., 2001). E2F1 is a specific and direct transcriptional activator of TAp73 but not p63 (Fig. 2) (Irwin et al., 2000; Stiewe and Putzer, 2000). Because oncogene deregulation of E2F1 and c-Myc are one of the most common genetic alterations in human tumors, these findings might provide a physiologic mechanism for TAp73 overexpression in tumors.

In a recent study, we showed that TAp73 is selective upregulated in BRCA1-associated ovarian tumors. Interestingly, we found that BRCA1-deficient ovarian carcinoma cells exhibit hypermethylation within a p73 regulatory region, which includes the binding site for the transcriptional repressor ZEB1. This hypermethylation leads to the abrogation of ZEB1 binding and hence increased expression of TAp73. Similarly, ZEB1 binding site methylation and TAp73 expression correlated with BRCA1 status in primary ovarian carcinomas and with clinical response to cisplatin (Fig. 2) (Ibrahim et al., 2010). Together, these data establish another important link between p73 and human cancer.

5.2 Regulation of p53 family protein stability

p53 is a short-lived protein, and its stability is very tightly regulated by ubiquitination under physiological condition (Haupt et al., 1997; Honda et al., 1997; Kubbutat et al., 1997). Polyubiquitination of p53 is carried out by the ubiquitin ligase MDM2. The polyubiquitination and degradation of p53 is influenced by a variety of factors including regulated changes in the subcellular localization of p53 and MDM2. Moreover, MDM2 itself is a p53-inducible gene, and thus activation of p53 establishes a negative feedback loop wherein MDM2 limits p53 accumulation (Fig. 2) (Barak et al., 1993; Irwin and Kaelin, 2001). In addition to its role in p53 degradation, MDM2 also binds to a sequence in the transactivation domain of p53 (amino acid residues 17–27) and thereby inhibits p53-dependent transactivation (Momand et al., 1992). The MDM2 binding site in p53 is well conserved in both p63 and p73. Several groups have shown that MDM2 bind to p73 and prevent it from binding to the transcriptional coactivators p300 and CBP (Balint et al., 1999; Ongkeko et al., 1999; Zeng et al., 1999; Zeng et al., 2000). This leads to impaired p73-dependent transcriptional activation and diminished apoptosis. Of note, like p53, p73 can activate the MDM2 promoter (Wang et al., 2001b; Zeng et al., 1999; Zhu et al., 1998). Although MDM2 does not target p73 for polyubiquitination, p73 stability is indirectly dependent upon the activity of the proteasome. Specifically, many proteasome inhibitors have been shown to increase p73 levels (Balint et al., 1999; Irwin and Kaelin, 2001; Ongkeko et al., 1999). Thus, it is possible that p73 is polyubiquitinated in cells by a yet unknown E3 ligase.

Unlike p73 and p53, p63 does not bind to either MDM2 (Wang et al., 2001a). Although there are no data implicating ubiquitination pathways in p63 degradation, Ratovitski *et al.* (2001) showed that p63 abundance could be regulated by caspase-dependent proteolysis due to the presence of a caspase recognition site, YVED, in the amino acid sequence (Irwin and Kaelin, 2001; Ratovitski et al., 2001).

Besides MDM2, the degradation and protein stability of p53 family proteins might be regulated by small ubiquitin-related modifier-1 (SUMO-1) (Minty et al., 2000; Moll and Slade, 2004). Conjugation to SUMO-1 has been shown to affect p53 transcriptional activity but does not appear to influence p53 stability (Fig. 2) (Gostissa et al., 1999; Irwin and Kaelin, 2001; Rodriguez et al., 2001). Nevertheless, modification of p73 α by SUMO-1 has been reported to alter p73 subcellular localization and increased the rate of p73 degradation. On the other hand, the novel Hect domain containing NEDD4-like E3 ubiquitin ligase, NEDL2, binds to p73 via its PY motif in the C-terminal region (Miyazaki et al., 2003). p53, which lacks the PY motif, does not bind to NEDL2. Overexpression of NEDL2 results in the ubiquitination of p73. However, rather than mediating degradation, ubiquitination by NEDL2 enhances the stability of p73 and its ability to transactivate p53/p73-responsive

promoters (Fig. 2). The differential binding of NEDL2 to p53 family members is thus another factor that might contribute to their functional divergence. Likewise, the NAD(P)H:quinone oxidoreductase-1 (NQO1) stabilizes p73 α (as well as p53) but not p73 β by binding to the SAM domain of p73 α and protect p73 α from 20S proteasomal degradation.. This NQO1-mediated stabilization of p73 α and p53 might explain why NQO1 knockout mice and human with inactive NQO1 polymorphisms are susceptible to cancer (Asher et al., 2002; Moll and Slade, 2004).

5.3 Regulation of p53 family protein transcriptional activity

The ankyrin-rich, Src homology 3 domain, proline-rich proteins, ASPP1 and ASPP2, stimulate the apoptotic function of p53, p63, and p73 (Bergamaschi et al., 2004; Samuels-Lev et al., 2001). By binding to the DBD of p53, p63, and p73, ASPP1 and ASPP2 stimulate the transactivation function of all three proteins on the promoters of *BAX*, *PIG3*, and *PUMA* but not *MDM2* or *p21^{WAF-1/CIP1}*. Hence, ASPP1 and ASPP2 are the first two identified common activators of all p53 family members.

The transcriptional coactivator Yes-associated protein (YAP) has also been shown to potentiate TAp73-mediated transactivation of *BAX* after DNA damage. Conversely, Akt phosphorylates YAP, which induces interaction with 14-3-3, relocation of YAP to the cytoplasm, and attenuation of p73-mediated apoptosis (Basu et al., 2003; Moll and Slade, 2004).

5.4 DNA damage response and postranslational modification

p53 stabilization and activation by genotoxic stress is associated with multiple post-translational modifications at the N- and C-termini of p53. Under genotoxic stress, activation of stress kinases such ATM, ATR, and Chk2 lead to phosphorylation of p53 at multiple residues at Ser15, Ser20, Ser33, Ser37, Ser46, Thr18, Thr81, Ser315 and Ser392 to stabilize the protein by interfering with MDM2 binding (Fig. 2). In addition, acetylation at Lys320, Lys373, and Lys382, and sumoylation at Lys386 have also been reported to activate the transcriptional activity of p53 (Appella, 2001).

p73 is also activated for apoptosis in response to various genotoxic agents including cisplatin, taxol, and γ -irradiation. The activation of p73 is highly dependent on the non-receptor tyrosine kinase c-abl (Agami et al., 1999; Gong et al., 1999; Moll and Slade, 2004; Yuan et al., 1999). In response to γ -irradiation and cisplatin, TAp73 undergoes phosphorylation at Tyr99 by c-abl (Fig. 2). This, in turn, lead to the stabilization of the protein and dissociation of TAp73 from the TAp73/ Δ Np63 inhibitory complex followed by apoptosis (Agami et al., 1999; Leong et al., 2007; Tsai and Yuan, 2003; Yuan et al., 1999).

The activation and phosphorylation of p73 is mainly through the direct interaction between the PXXP motifs of p73 and the Src homology 3 domain of c-abl (Moll and Slade, 2004). Because c-abl is itself phosphorylated and activated by the ATM, ATM may also be involved in the pathway leading to c-abl-dependent p73 activation (Shaul, 2000). These findings suggest that p73 might participate in a mismatch-repair signaling pathway. Recent microarray gene expression profiles further support a role for p73 in response to and repair of DNA damage (Vikhanskaya et al., 2001). In addition to cisplatin, Taxol also increases p73 accumulation, but UV irradiation, actinomycin D, and methylmethane sulfonate do not (Irwin and Kaelin, 2001; Levrero et al., 1999). As p63 does not have the PXXP motifs, it is unlikely that c-abl will phosphorylate p63 (Moll and Slade, 2004).

In addition to c-abl, p73 proteins may also be regulated by cyclin-CDK complexes and play a role in the regulation of cell cycle. p73 physically interacts with various cyclins and certain cyclin-CDK complexes including cyclin A-CDK1/2, cyclin B-CDK1/2, and cyclin E-CDK2, which can phosphorylate various p73 isoforms *in vitro* at Thr86. This cell cycle-dependent phosphorylation inhibits p73 to induce endogenous p21 expression (Gaiddon et al., 2003). p73 is a physiologic target of the cyclin B-CDK1 mitotic kinase complex *in vivo*, which results in a decreased ability of p73 to bind DNA and activate transcription in mitotic cells. Thus, both p73 α and p73 β isoforms have been shown to be hyperphosphorylated in normal mitotic cells (Fulco et al., 2003).

DNA damage also induces acetylation of p73 at Lys321, Lys327, and Lys331 by the acetyltransferase p300/cAMP-responsive element binding protein. Non-acetylated p73 is defective in inducing proapoptotic genes such as p53AIP1 but retains the ability to activate other target genes such as p21. This indicates that DNA damage-dependent p73 acetylation, like in p53, potentiates the apoptotic function of p73 by selectively increasing its ability to induce the transcription of proapoptotic target genes (Costanzo et al., 2002; Moll and Slade, 2004).

Finally, the mammalian target of rapamycin (mTOR) was recently identified as a negative regulator of p73 (Fig. 2). Notably, pharmacologic inhibition of mTOR in primary human mammary epithelial cells resulted in differential regulation of p53 family members (Rosenbluth et al., 2008). Cells exhibited selective up-regulation of TAp73, whereas Δ Np63 and p53 levels were both decreased. Interestingly, inhibition of mTOR by rapamycin synergizes cisplatin sensitivity in breast cancer cells through upregulation of TAp73 (Wong et al., 2010). Since mTOR is a master regulator of energy homeostasis and cell growth, and is often active in tumors (Guertin and Sabatini, 2007), this suggests that mTOR may inhibit TAp73 in tumors. In general, cancer cells may use upstream kinases or cofactors to inhibit p53 family members in different cellular contexts, ultimately maintaining proliferation and survival (Rosenbluth and Pietenpol, 2008).

6. The p53 pathway as a network

The significance interplay between p53 family and their isoforms in tumor is demonstrated by the fact that p53 cannot induce apoptosis in response to DNA damage, without the presence of p63 and p73 (Flores et al., 2002). Various mechanisms by which p53/p63/p73 proteins and their isoforms determine the cell fate through formation of transdominant heterocomplex, promoter competition and autoregulatory feedback loop have been proposed. These mechanisms are likely to play an important role in the transition between normal cell cycling and the onset of tumor formation.

6.1 Homotypic and heterotypic interactions among p53 family members

Physical interaction between oncogenic and antioncogenic p53 family members have been demonstrated to interfere with the tumor suppressor functions of wild-type p53 and TAp73 (Nakagawa et al., 2002; Stiewe et al., 2003; Stiewe et al., 2002a; Zaika et al., 2002). Mixed protein complexes were found between endogenous Δ Np73 α or Δ Np73 β on the one hand and either wild-type p53, TAp73 α , or TAp73 β on the other hand in primary human tumors, cultured human tumor cells, and mouse neurons (Moll and Slade, 2004). In human head and neck squamous cell carcinoma and triple-negative breast cancer, endogenous Δ Np63 was shown to physically interact with TAp73 and suppresses TAp73 tumor suppressor activities (Fig. 2) (Leong et al., 2007; Rocco et al., 2006).

In addition, physical interactions between certain human p53 mutants and TAp73 or TAp63 proteins have been reported in coimmunoprecipitation assays, and these interactions correlate with functional transdominance. In contrast, complexes between wild-type p53 and p73 are not observed in mammalian cells (Di Como et al., 1999; Marin et al., 2000; Pozniak et al., 2000; Vikhanskaya et al., 2000). Unexpectedly, protein contact occurs between the DBD of mutant p53 and the DBD and oligomerization domain of p73 rather than between the respective oligomerization domains (Davison et al., 1999; Gaiddon et al., 2001; Strano et al., 2000; Vikhanskaya et al., 2000). In cotransfection experiments, mixed heterocomplexes were shown between p53 mutants p53Ala143, p53Leu173, p53His175, p53Cys220, p53Trp248, or p53Gly281 and TAp73 α , TAp73 γ , TAp73 δ and TAp63 (Di Como et al., 1999; Gaiddon et al., 2001; Marin et al., 2000; Strano et al., 2000). Physiologic complexes were found in five tumor cell lines between endogenous mutant p53 and p73 (Marin et al., 2000; Strano et al., 2000). Functionally, formation of such stable complexes leads to a loss of p73- and p63-mediated transactivation and proapoptotic abilities. Moreover, E2F1-induced p73 transactivation, apoptosis, and colony suppression was inhibited by coexpressed p53His175 (Stiewe and Putzer, 2000). Interestingly, the Arg/Pro polymorphism at codon 72 of mutant p53 is a biological determinant for binding and inactivation of p73, with 72R mutants of p53 being inhibitory, whereas 72P mutants are not (Fig. 2) (Bergamaschi et al., 2003; Marin et al., 2000; Moll and Slade, 2004).

This functional inhibition of TAp73 or TAp63 by some p53 mutants mirrors the ability of many transdominant missense p53 mutants to abrogate wild-type p53 function (Kern et al., 1992; Unger et al., 1992). It suggests that in tumors that express both TAp73 and mutant p53 (typically at very high levels due to deficient MDM2-mediated degradation), the function of TAp73 and TAp63 might be inactivated. If this occurs in primary human tumors, it might have far-reaching consequences because (a) it argues for a transdominant inhibition of the tumor suppressor function of TAp73 isoforms during tumor development, (b) it could be the underlying mechanism for the gain-of-function activity of certain p53 mutants, and (c) it might further increase chemoresistance in cancer therapy of established tumors.

p53 is exceptional among tumor suppressors in that it selects for the overexpression of missense mutants rather than for loss of expression as most other suppressor genes do. This gain-of function increased tumorigenicity compared with p53-null parental cells, increased resistance to cancer agents, and increased genomic instability due to abrogation of the mitotic spindle checkpoint (Dittmer et al., 1993; Halevy et al., 1990; Shaulsky et al., 1991). Conceivably, p63 might also participate in this network. A recent study shown that mutant p53His273 is required for survival of breast cancer cells as knock-down of endogenous mutant p53His273 in breast cancer cells induces massive apoptosis. Surprisingly, the survival effects of p53His273 is independent of TAp73 or TAp63 function as depletion of both isoforms did not rescue the cells from apoptosis following p53His273 knock-down (Lim et al., 2009). Therefore, it is important to note that not all p53 mutants have transdominant effects against TAp73 or TAp63. Some p53 mutants are clearly recessive toward TAp73 (e.g., p53His283, p53Tyr277 and p53His273) and do not interfere with its action (Gaiddon et al., 2001; Lim et al., 2009; Moll and Slade, 2004).

6.2 Promoter competition

Promoter competition by Δ Np73 and Δ Np63 at TAp73/p53 response elements has been reported previously (Kartasheva et al., 2002; Rocco et al., 2006; Stiewe et al., 2002a). It is conceivable that Δ Np73 or Δ Np63 homo-oligomers might have a stronger affinity to certain

target gene promoters than wild-type p53 or TAp73. In those cases, p53 or TAp73 inhibition could occur due to competition at the level of target gene access. In the wild-type p53-containing ovarian carcinoma cell line A2780, coexpression of increasing amounts of either TAp73 α , TAp73 β , TAp73 γ , or TAp73 ϵ inhibits specific DNA binding and transcriptional activity of p53 in the absence of hetero-oligomer formation (Moll and Slade, 2004; Ueda et al., 1999; Vikhanskaya et al., 2000). These results suggest that promoter competition could be another mechanism for transdominance between p53 family proteins.

6.3 Autoregulatory feedback loop among p53, TAp73, and Δ Np73

p53 and TAp73 regulate Δ Np73 but not Δ Np63 levels by binding to the p73 P2 promoter and inducing its transcription (Fig. 2). A p73-specific responsive element was mapped within the P2 region (Nakagawa et al., 2002). This generates a negative feedback loop analogous negatively regulates the activity of p53 and p73 (Grob et al., 2001; Kartasheva et al., 2002; Nakagawa et al., 2002; Vossio et al., 2002). As mentioned earlier, Δ Np73 blocks p53 and TAp73 activity through heterocomplex formation (Nakagawa et al., 2002; Stiewe et al., 2002a; Zaika et al., 2002) or through promoter competition (Kartasheva et al., 2002; Stiewe et al., 2002a) and thus contributes to the termination of the p53/p73 response in cells. In contrast to Δ Np73, Δ Np63 expression is transcriptionally repressed by p53 (Moll and Slade, 2004; Waltermann et al., 2003).

7. Targeting the p53 family for treatment of breast cancers

As described above, activation of wild-type TAp73 (or TAp63) lead to cell death in cancer cells. This hypothesis is intriguing given the fact that p73 and p63 are rarely mutated in cancer. Instead, overexpression of TAp73 has been reported in many tumor types including breast cancers and head and neck squamous carcinoma (Leong et al., 2007; Rocco et al., 2006). As such, selective activation of TAp73 (or TAp63) might induce tumor specific cell death. In principle, activation of the p53 family tumor suppressive pathways might be achieved in several ways (Kaelin, 1999).

First, induction and activation of TAp73 have been reported in response to wide variety of chemotherapeutic agents including Adriamycin, cisplatin, taxol, and etoposide in different tumor cell lines (Bergamaschi et al., 2003; Irwin et al., 2003; Moll and Slade, 2004). In particular, cisplatin treatment has been shown to induce c-abl dependent phosphorylation of TAp73 and lead to its dissociation from the TAp73/ Δ Np63 inhibitory complex in head and neck squamous cell carcinoma and breast cancer cells (Fig. 2) (Leong et al., 2007; Rocco et al., 2006). Similarly, a recent clinical study also shown that cells that co-overexpressed TAp73 and Δ Np63 is more likely to response to cisplatin compare to tumors that have no TAp73 expression. These results suggest that certain chemotherapeutic agents can activate TAp73 even in the presence of high level of Δ N isoforms.

Second, a more detailed understanding of the upstream signals that impinge upon p73 and p63 might allow for the design of drugs that would activate the transcription of these genes or stabilize their protein products. For example, the mammalian target of rapamycin (mTOR) was recently identified as a negative regulator of p73 (Rosenbluth et al., 2008). Inhibition of mTOR in primary human mammary epithelial cells selectively up-regulate TAp73 (Rosenbluth et al., 2008; Rosenbluth and Pietenpol, 2008). Combination of cisplatin and mTOR inhibitor, rapamycin, has also been shown to synergizes cisplatin sensitivity in basal-like breast cancer cells through up-regulation of TAp73 recently (Fig. 2) (Wong et al.,

2010). Of note, a phase II neo-adjuvant clinical trial of cisplatin and mTOR inhibitor, everolimus, in patients with triple-negative breast cancer has recently opened for recruitment (ClinicalTrials.gov Identifier: NCT00930930) and will be able to directly address whether targeting these pathways will increase the sensitivity of tumors towards cisplatin chemotherapy.

Finally, it might be possible to design or discover drugs that block the interaction of mutant p53 with p73 or intreraction of MDM2 with p73 which has been shown to inhibit p73 transcription activity (Kaelin, 1999). In theory, molecules already in development that block the interaction of MDM2 with p53 or molecules that restore mutant p53 function might also function in this setting. For example, PRIMA-1, CP-31398 and MIRA-1 are molecules that have been shown to restore wild-type conformation and transcriptional transactivation to mutant p53 (Fig. 2) (Wiman, 2006). Similarly, MDM2 inhibitor such as Nutlins, might interfere MDM2-p73 binding and hence restore the tumor suppressor function of p73 (Ambrosini et al., 2007; Shangary and Wang, 2008). Whether these molecules will selectively activate TAp73 remain to be investigated.

8. Concluding remarks

In conclusion, studies of the newly identified p53 family members, p63 and p73, have revealed several structural and functional similarities. The p53 transactivation, DNA binding, and oligomerization domains are highly conserved among all family members. Like p53, p63 and p73 can form oligomers, bind DNA, and transactivate the promoters of a subset of p53 target genes and induce apoptosis. In addition, certain cellular and viral proteins known to bind and regulate p53 activity likewise can bind to p63 and p73.

Despite the fact that p63 and p73 mimic many p53 activities, more recent studies highlight significant differences between the family members. In contrast to *p53*, *p63* and *p73* give rise to multiple functionally distinct protein isoforms due to alternative promoter utilization and alternative mRNA splicing. The ΔN isoforms, which lack the N-terminal transactivation domain, can function as “dominant-negative” proteins, blocking certain activities of the corresponding full-length proteins.

Differences in the upstream signaling pathways involved in activation of each of the family members are also becoming apparent. Only a subset of the DNA-damaging agents that induce p53 also induce p73. Many cellular and viral oncoproteins also discriminate between p53 and the newer family members. Finally, it is becoming apparent that *p63* and *p73* are not classical Knudson-type tumor suppressor genes. In particular, these genes are not frequently mutated in tumors, and germ-line mutations in these genes do not cause tumors in mice. Instead, mice with deletions in *p63* and *p73* have significant developmental abnormalities.

Despite the significant advances in understanding the unique roles of p53, p63 and p73, there are still several outstanding questions. Understanding the complexity of p53 family members interactions may allow us to delineate the function of the p53 family network in human tumorigenesis and facilitate the development of anticancer therapeutics that seek to induce the activation of “p53-responsive” genes in cells lacking wild-type p53.

9. References

Abraham, H., and Meyer, G. (2003). Reelin-expressing neurons in the postnatal and adult human hippocampal formation. *Hippocampus* 13, 715-727.

- Agami, R., Blandino, G., Oren, M., and Shaul, Y. (1999). Interaction of c-Abl and p73alpha and their collaboration to induce apoptosis. *Nature* 399, 809-813.
- Ambrosini, G., Sambol, E. B., Carvajal, D., Vassilev, L. T., Singer, S., and Schwartz, G. K. (2007). Mouse double minute antagonist Nutlin-3a enhances chemotherapy-induced apoptosis in cancer cells with mutant p53 by activating E2F1. *Oncogene* 26, 3473-3481.
- Appella, E. (2001). Modulation of p53 function in cellular regulation. *Eur J Biochem* 268, 2763.
- Arrowsmith, C. H. (1999). Structure and function in the p53 family. *Cell Death Differ* 6, 1169-1173.
- Asher, G., Lotem, J., Sachs, L., Kahana, C., and Shaul, Y. (2002). Mdm-2 and ubiquitin-independent p53 proteasomal degradation regulated by NQO1. *Proc Natl Acad Sci U S A* 99, 13125-13130.
- Balint, E., Bates, S., and Vousden, K. H. (1999). Mdm2 binds p73 alpha without targeting degradation. *Oncogene* 18, 3923-3929.
- Barak, Y., Juven, T., Haffner, R., and Oren, M. (1993). mdm2 expression is induced by wild type p53 activity. *EMBO J* 12, 461-468.
- Basu, S., Totty, N. F., Irwin, M. S., Sudol, M., and Downward, J. (2003). Akt phosphorylates the Yes-associated protein, YAP, to induce interaction with 14-3-3 and attenuation of p73-mediated apoptosis. *Mol Cell* 11, 11-23.
- Benard, J., Douc-Rasy, S., and Ahomadegbe, J. C. (2003). TP53 family members and human cancers. *Hum Mutat* 21, 182-191.
- Bergamaschi, D., Gasco, M., Hiller, L., Sullivan, A., Syed, N., Trigiante, G., Yulug, I., Merlano, M., Numico, G., Comino, A., *et al.* (2003). p53 polymorphism influences response in cancer chemotherapy via modulation of p73-dependent apoptosis. *Cancer Cell* 3, 387-402.
- Bergamaschi, D., Samuels, Y., Jin, B., Duraisingham, S., Crook, T., and Lu, X. (2004). ASPP1 and ASPP2: common activators of p53 family members. *Mol Cell Biol* 24, 1341-1350.
- Bjorkqvist, A. M., Husgafvel-Pursiainen, K., Anttila, S., Karjalainen, A., Tammilehto, L., Mattson, K., Vainio, H., and Knuutila, S. (1998). DNA gains in 3q occur frequently in squamous cell carcinoma of the lung, but not in adenocarcinoma. *Genes Chromosomes Cancer* 22, 79-82.
- Blanpain, C., and Fuchs, E. (2007). p63: revving up epithelial stem-cell potential. *Nat Cell Biol* 9, 731-733.
- Brunner, H. G., Hamel, B. C., and Bokhoven Hv, H. (2002). P63 gene mutations and human developmental syndromes. *Am J Med Genet* 112, 284-290.
- Cai, Y. C., Yang, G. Y., Nie, Y., Wang, L. D., Zhao, X., Song, Y. L., Seril, D. N., Liao, J., Xing, E. P., and Yang, C. S. (2000). Molecular alterations of p73 in human esophageal squamous cell carcinomas: loss of heterozygosity occurs frequently; loss of imprinting and elevation of p73 expression may be related to defective p53. *Carcinogenesis* 21, 683-689.
- Celli, J., Duijf, P., Hamel, B. C., Bamshad, M., Kramer, B., Smits, A. P., Newbury-Ecob, R., Hennekam, R. C., Van Buggenhout, G., van Haeringen, A., *et al.* (1999). Heterozygous germline mutations in the p53 homolog p63 are the cause of EEC syndrome. *Cell* 99, 143-153.

- Chan, I., McGrath, J. A., and Kivirikko, S. (2005). Rapp-Hodgkin syndrome and the tail of p63. *Clin Exp Dermatol* 30, 183-186.
- Chen, C. L., Ip, S. M., Cheng, D., Wong, L. C., and Ngan, H. Y. (2000). P73 gene expression in ovarian cancer tissues and cell lines. *Clin Cancer Res* 6, 3910-3915.
- Chi, S. G., Chang, S. G., Lee, S. J., Lee, C. H., Kim, J. I., and Park, J. H. (1999). Elevated and biallelic expression of p73 is associated with progression of human bladder cancer. *Cancer Res* 59, 2791-2793.
- Choi, H. R., Batsakis, J. G., Zhan, F., Sturgis, E., Luna, M. A., and El-Naggar, A. K. (2002). Differential expression of p53 gene family members p63 and p73 in head and neck squamous tumorigenesis. *Hum Pathol* 33, 158-164.
- Costanzo, A., Merlo, P., Pediconi, N., Fulco, M., Sartorelli, V., Cole, P. A., Fontemaggi, G., Fanciulli, M., Schiltz, L., Blandino, G., *et al.* (2002). DNA damage-dependent acetylation of p73 dictates the selective activation of apoptotic target genes. *Mol Cell* 9, 175-186.
- Crook, T., Nicholls, J. M., Brooks, L., O'Nions, J., and Allday, M. J. (2000). High level expression of deltaN-p63: a mechanism for the inactivation of p53 in undifferentiated nasopharyngeal carcinoma (NPC)? *Oncogene* 19, 3439-3444.
- Davis, L. D., Zhang, W., Merseburger, A., Young, D., Xu, L., Rhim, J. S., Moul, J. W., Srivastava, S., and Sesterhenn, I. A. (2002). p63 expression profile in normal and malignant prostate epithelial cells. *Anticancer Res* 22, 3819-3825.
- Davison, T. S., Vagner, C., Kaghad, M., Ayed, A., Caput, D., and Arrowsmith, C. H. (1999). p73 and p63 are homotetramers capable of weak heterotypic interactions with each other but not with p53. *J Biol Chem* 274, 18709-18714.
- De Laurenzi, V., Costanzo, A., Barcaroli, D., Terrinoni, A., Falco, M., Annicchiarico-Petruzzelli, M., Levrero, M., and Melino, G. (1998). Two new p73 splice variants, gamma and delta, with different transcriptional activity. *J Exp Med* 188, 1763-1768.
- Di Como, C. J., Gaiddon, C., and Prives, C. (1999). p73 function is inhibited by tumor-derived p53 mutants in mammalian cells. *Mol Cell Biol* 19, 1438-1449.
- Di Como, C. J., Urist, M. J., Babayan, I., Drobnjak, M., Hedvat, C. V., Teruya-Feldstein, J., Pohar, K., Hoos, A., and Cordon-Cardo, C. (2002). p63 expression profiles in human normal and tumor tissues. *Clin Cancer Res* 8, 494-501.
- Dittmer, D., Pati, S., Zambetti, G., Chu, S., Teresky, A. K., Moore, M., Finlay, C., and Levine, A. J. (1993). Gain of function mutations in p53. *Nat Genet* 4, 42-46.
- Dobbelstein, M., and Roth, J. (1998). The large T antigen of simian virus 40 binds and inactivates p53 but not p73. *J Gen Virol* 79 (Pt 12), 3079-3083.
- Dohn, M., Zhang, S., and Chen, X. (2001). p63alpha and DeltaNp63alpha can induce cell cycle arrest and apoptosis and differentially regulate p53 target genes. *Oncogene* 20, 3193-3205.
- Duijf, P. H., Vanmolkot, K. R., Propping, P., Friedl, W., Krieger, E., McKeon, F., Dotsch, V., Brunner, H. G., and van Bokhoven, H. (2002). Gain-of-function mutation in ADULT syndrome reveals the presence of a second transactivation domain in p63. *Hum Mol Genet* 11, 799-804.
- Flores, E. R., Tsai, K. Y., Crowley, D., Sengupta, S., Yang, A., McKeon, F., and Jacks, T. (2002). p63 and p73 are required for p53-dependent apoptosis in response to DNA damage. *Nature* 416, 560-564.

- Fomenkov, A., Huang, Y. P., Topaloglu, O., Brechman, A., Osada, M., Fomenkova, T., Yuriditsky, E., Trink, B., Sidransky, D., and Ratovitski, E. (2003). P63 alpha mutations lead to aberrant splicing of keratinocyte growth factor receptor in the Hay-Wells syndrome. *J Biol Chem* 278, 23906-23914.
- Fulco, M., Costanzo, A., Merlo, P., Mangiacasale, R., Strano, S., Blandino, G., Balsano, C., Lavia, P., and Levrero, M. (2003). p73 is regulated by phosphorylation at the G2/M transition. *J Biol Chem* 278, 49196-49202.
- Gaiddon, C., Lokshin, M., Ahn, J., Zhang, T., and Prives, C. (2001). A subset of tumor-derived mutant forms of p53 down-regulate p63 and p73 through a direct interaction with the p53 core domain. *Mol Cell Biol* 21, 1874-1887.
- Gaiddon, C., Lokshin, M., Gross, I., Levasseur, D., Taya, Y., Loeffler, J. P., and Prives, C. (2003). Cyclin-dependent kinases phosphorylate p73 at threonine 86 in a cell cycle-dependent manner and negatively regulate p73. *J Biol Chem* 278, 27421-27431.
- Garraway, L. A., Lin, D., Signoretti, S., Waltregny, D., Dilks, J., Bhattacharya, N., and Loda, M. (2003). Intermediate basal cells of the prostate: in vitro and in vivo characterization. *Prostate* 55, 206-218.
- Gong, J. G., Costanzo, A., Yang, H. Q., Melino, G., Kaelin, W. G., Jr., Levrero, M., and Wang, J. Y. (1999). The tyrosine kinase c-Abl regulates p73 in apoptotic response to cisplatin-induced DNA damage. *Nature* 399, 806-809.
- Gostissa, M., Hengstermann, A., Fogal, V., Sandy, P., Schwarz, S. E., Scheffner, M., and Del Sal, G. (1999). Activation of p53 by conjugation to the ubiquitin-like protein SUMO-1. *EMBO J* 18, 6462-6471.
- Grob, T. J., Novak, U., Maise, C., Barcaroli, D., Luthi, A. U., Pirnia, F., Hugli, B., Graber, H. U., De Laurenzi, V., Fey, M. F., *et al.* (2001). Human delta Np73 regulates a dominant negative feedback loop for TAp73 and p53. *Cell Death Differ* 8, 1213-1223.
- Guertin, D. A., and Sabatini, D. M. (2007). Defining the role of mTOR in cancer. *Cancer Cell* 12, 9-22.
- Hagiwara, K., McMenamin, M. G., Miura, K., and Harris, C. C. (1999). Mutational analysis of the p63/p73L/p51/p40/CUSP/KET gene in human cancer cell lines using intronic primers. *Cancer Res* 59, 4165-4169.
- Halevy, O., Michalovitz, D., and Oren, M. (1990). Different tumor-derived p53 mutants exhibit distinct biological activities. *Science* 250, 113-116.
- Haupt, Y., Maya, R., Kazaz, A., and Oren, M. (1997). Mdm2 promotes the rapid degradation of p53. *Nature* 387, 296-299.
- Hibi, K., Trink, B., Patturajan, M., Westra, W. H., Caballero, O. L., Hill, D. E., Ratovitski, E. A., Jen, J., and Sidransky, D. (2000). AIS is an oncogene amplified in squamous cell carcinoma. *Proc Natl Acad Sci U S A* 97, 5462-5467.
- Higashino, F., Pipas, J. M., and Shenk, T. (1998). Adenovirus E4orf6 oncoprotein modulates the function of the p53-related protein, p73. *Proc Natl Acad Sci U S A* 95, 15683-15687.
- Honda, R., Tanaka, H., and Yasuda, H. (1997). Oncoprotein MDM2 is a ubiquitin ligase E3 for tumor suppressor p53. *FEBS Lett* 420, 25-27.
- Hu, J. F., Ulaner, G. A., Oruganti, H., Ivaturi, R. D., Balagura, K. A., Pham, J., Vu, T. H., and Hoffman, A. R. (2000). Allelic expression of the putative tumor suppressor gene p73 in human fetal tissues and tumor specimens. *Biochim Biophys Acta* 1491, 49-56.

- Ibrahim, N., He, L., Leong, C. O., Xing, D., Karlan, B. Y., Swisher, E. M., Rueda, B. R., Orsulic, S., and Ellisen, L. W. (2010). BRCA1-associated epigenetic regulation of p73 mediates an effector pathway for chemosensitivity in ovarian carcinoma. *Cancer Res* 70, 7155-7165.
- Irwin, M., Marin, M. C., Phillips, A. C., Seelan, R. S., Smith, D. I., Liu, W., Flores, E. R., Tsai, K. Y., Jacks, T., Vousden, K. H., and Kaelin, W. G., Jr. (2000). Role for the p53 homologue p73 in E2F-1-induced apoptosis. *Nature* 407, 645-648.
- Irwin, M. S., and Kaelin, W. G. (2001). p53 family update: p73 and p63 develop their own identities. *Cell Growth Differ* 12, 337-349.
- Irwin, M. S., Kondo, K., Marin, M. C., Cheng, L. S., Hahn, W. C., and Kaelin, W. G., Jr. (2003). Chemosensitivity linked to p73 function. *Cancer Cell* 3, 403-410.
- Johnson, J., Lagowski, J., Sundberg, A., and Kulesz-Martin, M. (2005). P53 family activities in development and cancer: relationship to melanocyte and keratinocyte carcinogenesis. *J Invest Dermatol* 125, 857-864.
- Jost, C. A., Marin, M. C., and Kaelin, W. G., Jr. (1997). p73 is a simian [correction of human] p53-related protein that can induce apoptosis. *Nature* 389, 191-194.
- Kaelin, W. G., Jr. (1999). The p53 gene family. *Oncogene* 18, 7701-7705.
- Kaghad, M., Bonnet, H., Yang, A., Creancier, L., Biscan, J. C., Valent, A., Minty, A., Chalon, P., Lelias, J. M., Dumont, X., *et al.* (1997). Monoallelically expressed gene related to p53 at 1p36, a region frequently deleted in neuroblastoma and other human cancers. *Cell* 90, 809-819.
- Kang, M. J., Park, B. J., Byun, D. S., Park, J. I., Kim, H. J., Park, J. H., and Chi, S. G. (2000). Loss of imprinting and elevated expression of wild-type p73 in human gastric adenocarcinoma. *Clin Cancer Res* 6, 1767-1771.
- Kartasheva, N. N., Contente, A., Lenz-Stoppler, C., Roth, J., and Dobbelstein, M. (2002). p53 induces the expression of its antagonist p73 Delta N, establishing an autoregulatory feedback loop. *Oncogene* 21, 4715-4727.
- Kern, S. E., Pietenpol, J. A., Thiagalingam, S., Seymour, A., Kinzler, K. W., and Vogelstein, B. (1992). Oncogenic forms of p53 inhibit p53-regulated gene expression. *Science* 256, 827-830.
- Koster, M. I., Kim, S., Mills, A. A., DeMayo, F. J., and Roop, D. R. (2004). p63 is the molecular switch for initiation of an epithelial stratification program. *Genes Dev* 18, 126-131.
- Kovalev, S., Marchenko, N., Swendeman, S., LaQuaglia, M., and Moll, U. M. (1998). Expression level, allelic origin, and mutation analysis of the p73 gene in neuroblastoma tumors and cell lines. *Cell Growth Differ* 9, 897-903.
- Kubbutat, M. H., Jones, S. N., and Vousden, K. H. (1997). Regulation of p53 stability by Mdm2. *Nature* 387, 299-303.
- Lane, D. P., and Crawford, L. V. (1979). T antigen is bound to a host protein in SV40-transformed cells. *Nature* 278, 261-263.
- Lechner, M. S., Mack, D. H., Finicle, A. B., Crook, T., Vousden, K. H., and Laimins, L. A. (1992). Human papillomavirus E6 proteins bind p53 in vivo and abrogate p53-mediated repression of transcription. *EMBO J* 11, 3045-3052.
- Lee, C. W., and La Thangue, N. B. (1999). Promoter specificity and stability control of the p53-related protein p73. *Oncogene* 18, 4171-4181.

- Leong, C. O., Vidnovic, N., DeYoung, M. P., Sgroi, D., and Ellisen, L. W. (2007). The p63/p73 network mediates chemosensitivity to cisplatin in a biologically defined subset of primary breast cancers. *J Clin Invest* 117, 1370-1380.
- Levrero, M., De Laurenzi, V., Costanzo, A., Gong, J., Melino, G., and Wang, J. Y. (1999). Structure, function and regulation of p63 and p73. *Cell Death Differ* 6, 1146-1153.
- Lim, L. Y., Vidnovic, N., Ellisen, L. W., and Leong, C. O. (2009). Mutant p53 mediates survival of breast cancer cells. *Br J Cancer* 101, 1606-1612.
- Linzer, D. I., and Levine, A. J. (1979). Characterization of a 54K dalton cellular SV40 tumor antigen present in SV40-transformed cells and uninfected embryonal carcinoma cells. *Cell* 17, 43-52.
- Lissy, N. A., Davis, P. K., Irwin, M., Kaelin, W. G., and Dowdy, S. F. (2000). A common E2F-1 and p73 pathway mediates cell death induced by TCR activation. *Nature* 407, 642-645.
- Mai, M., Yokomizo, A., Qian, C., Yang, P., Tindall, D. J., Smith, D. I., and Liu, W. (1998). Activation of p73 silent allele in lung cancer. *Cancer Res* 58, 2347-2349.
- Marin, M. C., Jost, C. A., Brooks, L. A., Irwin, M. S., O'Nions, J., Tidy, J. A., James, N., McGregor, J. M., Harwood, C. A., Yulug, I. G., *et al.* (2000). A common polymorphism acts as an intragenic modifier of mutant p53 behaviour. *Nat Genet* 25, 47-54.
- Marin, M. C., Jost, C. A., Irwin, M. S., DeCaprio, J. A., Caput, D., and Kaelin, W. G., Jr. (1998). Viral oncoproteins discriminate between p53 and the p53 homolog p73. *Mol Cell Biol* 18, 6316-6324.
- Massion, P. P., Taflan, P. M., Jamshedur Rahman, S. M., Yildiz, P., Shyr, Y., Edgerton, M. E., Westfall, M. D., Roberts, J. R., Pietenpol, J. A., Carbone, D. P., and Gonzalez, A. L. (2003). Significance of p63 amplification and overexpression in lung cancer development and prognosis. *Cancer Res* 63, 7113-7121.
- Melino, G., Lu, X., Gasco, M., Crook, T., and Knight, R. A. (2003). Functional regulation of p73 and p63: development and cancer. *Trends Biochem Sci* 28, 663-670.
- Mills, A. A., Zheng, B., Wang, X. J., Vogel, H., Roop, D. R., and Bradley, A. (1999). p63 is a p53 homologue required for limb and epidermal morphogenesis. *Nature* 398, 708-713.
- Minty, A., Dumont, X., Kaghad, M., and Caput, D. (2000). Covalent modification of p73alpha by SUMO-1. Two-hybrid screening with p73 identifies novel SUMO-1-interacting proteins and a SUMO-1 interaction motif. *J Biol Chem* 275, 36316-36323.
- Miyazaki, K., Ozaki, T., Kato, C., Hanamoto, T., Fujita, T., Irino, S., Watanabe, K., Nakagawa, T., and Nakagawara, A. (2003). A novel HECT-type E3 ubiquitin ligase, NEDL2, stabilizes p73 and enhances its transcriptional activity. *Biochem Biophys Res Commun* 308, 106-113.
- Moll, U. M., and Slade, N. (2004). p63 and p73: roles in development and tumor formation. *Mol Cancer Res* 2, 371-386.
- Momand, J., Zambetti, G. P., Olson, D. C., George, D., and Levine, A. J. (1992). The mdm-2 oncogene product forms a complex with the p53 protein and inhibits p53-mediated transactivation. *Cell* 69, 1237-1245.
- Murray-Zmijewski, F., Lane, D. P., and Bourdon, J. C. (2006). p53/p63/p73 isoforms: an orchestra of isoforms to harmonise cell differentiation and response to stress. *Cell Death Differ* 13, 962-972.

- Nakagawa, T., Takahashi, M., Ozaki, T., Watanabe Ki, K., Todo, S., Mizuguchi, H., Hayakawa, T., and Nakagawara, A. (2002). Autoinhibitory regulation of p73 by Delta Np73 to modulate cell survival and death through a p73-specific target element within the Delta Np73 promoter. *Mol Cell Biol* 22, 2575-2585.
- Nakano, K., Balint, E., Ashcroft, M., and Vousden, K. H. (2000). A ribonucleotide reductase gene is a transcriptional target of p53 and p73. *Oncogene* 19, 4283-4289.
- Ng, S. W., Yiu, G. K., Liu, Y., Huang, L. W., Palnati, M., Jun, S. H., Berkowitz, R. S., and Mok, S. C. (2000). Analysis of p73 in human borderline and invasive ovarian tumor. *Oncogene* 19, 1885-1890.
- Nomoto, S., Haruki, N., Kondo, M., Konishi, H., and Takahashi, T. (1998). Search for mutations and examination of allelic expression imbalance of the p73 gene at 1p36.33 in human lung cancers. *Cancer Res* 58, 1380-1383.
- Ongkeko, W. M., Wang, X. Q., Siu, W. Y., Lau, A. W., Yamashita, K., Harris, A. L., Cox, L. S., and Poon, R. Y. (1999). MDM2 and MDMX bind and stabilize the p53-related protein p73. *Curr Biol* 9, 829-832.
- Osada, M., Ohba, M., Kawahara, C., Ishioka, C., Kanamaru, R., Katoh, I., Ikawa, Y., Nimura, Y., Nakagawara, A., Obinata, M., and Ikawa, S. (1998). Cloning and functional analysis of human p51, which structurally and functionally resembles p53. *Nat Med* 4, 839-843.
- Ozaki, T., Naka, M., Takada, N., Tada, M., Sakiyama, S., and Nakagawara, A. (1999). Deletion of the COOH-terminal region of p73alpha enhances both its transactivation function and DNA-binding activity but inhibits induction of apoptosis in mammalian cells. *Cancer Res* 59, 5902-5907.
- Park, B. J., Lee, S. J., Kim, J. I., Lee, C. H., Chang, S. G., Park, J. H., and Chi, S. G. (2000). Frequent alteration of p63 expression in human primary bladder carcinomas. *Cancer Res* 60, 3370-3374.
- Pozniak, C. D., Radinovic, S., Yang, A., McKeon, F., Kaplan, D. R., and Miller, F. D. (2000). An anti-apoptotic role for the p53 family member, p73, during developmental neuron death. *Science* 289, 304-306.
- Prabhu, N. S., Somasundaram, K., Satyamoorthy, K., Herlyn, M., and El-Deiry, W. S. (1998). p73beta, unlike p53, suppresses growth and induces apoptosis of human papillomavirus E6-expressing cancer cells. *Int J Oncol* 13, 5-9.
- Ratovitski, E. A., Patturajan, M., Hibi, K., Trink, B., Yamaguchi, K., and Sidransky, D. (2001). p53 associates with and targets Delta Np63 into a protein degradation pathway. *Proc Natl Acad Sci U S A* 98, 1817-1822.
- Reis-Filho, J. S., Milanezi, F., Amendoeira, I., Albergaria, A., and Schmitt, F. C. (2003a). Distribution of p63, a novel myoepithelial marker, in fine-needle aspiration biopsies of the breast: an analysis of 82 samples. *Cancer* 99, 172-179.
- Reis-Filho, J. S., Simpson, P. T., Martins, A., Preto, A., Gartner, F., and Schmitt, F. C. (2003b). Distribution of p63, cytokeratins 5/6 and cytokeratin 14 in 51 normal and 400 neoplastic human tissue samples using TARP-4 multi-tumor tissue microarray. *Virchows Arch* 443, 122-132.
- Ribeiro-Silva, A., Zambelli Ramalho, L. N., Britto Garcia, S., and Zucoloto, S. (2003). The relationship between p63 and p53 expression in normal and neoplastic breast tissue. *Arch Pathol Lab Med* 127, 336-340.

- Rocco, J. W., Leong, C. O., Kuperwasser, N., DeYoung, M. P., and Ellisen, L. W. (2006). p63 mediates survival in squamous cell carcinoma by suppression of p73-dependent apoptosis. *Cancer Cell* 9, 45-56.
- Rodriguez, M. S., Dargemont, C., and Hay, R. T. (2001). SUMO-1 conjugation in vivo requires both a consensus modification motif and nuclear targeting. *J Biol Chem* 276, 12654-12659.
- Rosenbluth, J. M., Mays, D. J., Pino, M. F., Tang, L. J., and Pietenpol, J. A. (2008). A gene signature-based approach identifies mTOR as a regulator of p73. *Mol Cell Biol* 28, 5951-5964.
- Rosenbluth, J. M., and Pietenpol, J. A. (2008). The jury is in: p73 is a tumor suppressor after all. *Genes Dev* 22, 2591-2595.
- Roth, J., and Dobbelstein, M. (1999). Failure of viral oncoproteins to target the p53-homologue p51A. *J Gen Virol* 80 (Pt 12), 3251-3255.
- Roth, J., Konig, C., Wienzek, S., Weigel, S., Ristea, S., and Dobbelstein, M. (1998). Inactivation of p53 but not p73 by adenovirus type 5 E1B 55-kilodalton and E4 34-kilodalton oncoproteins. *J Virol* 72, 8510-8516.
- Samuels-Lev, Y., O'Connor, D. J., Bergamaschi, D., Trigiante, G., Hsieh, J. K., Zhong, S., Campargue, I., Naumovski, L., Crook, T., and Lu, X. (2001). ASPP proteins specifically stimulate the apoptotic function of p53. *Mol Cell* 8, 781-794.
- Sarnow, P., Ho, Y. S., Williams, J., and Levine, A. J. (1982). Adenovirus E1b-58kd tumor antigen and SV40 large tumor antigen are physically associated with the same 54 kd cellular protein in transformed cells. *Cell* 28, 387-394.
- Schmale, H., and Bamberger, C. (1997). A novel protein with strong homology to the tumor suppressor p53. *Oncogene* 15, 1363-1367.
- Senoo, M., Pinto, F., Crum, C. P., and McKeon, F. (2007). p63 Is essential for the proliferative potential of stem cells in stratified epithelia. *Cell* 129, 523-536.
- Senoo, M., Seki, N., Ohira, M., Sugano, S., Watanabe, M., Inuzuka, S., Okamoto, T., Tachibana, M., Tanaka, T., Shinkai, Y., and Kato, H. (1998). A second p53-related protein, p73L, with high homology to p73. *Biochem Biophys Res Commun* 248, 603-607.
- Shangary, S., and Wang, S. (2008). Targeting the MDM2-p53 interaction for cancer therapy. *Clin Cancer Res* 14, 5318-5324.
- Shaul, Y. (2000). c-Abl: activation and nuclear targets. *Cell Death Differ* 7, 10-16.
- Shaulsky, G., Goldfinger, N., and Rotter, V. (1991). Alterations in tumor development in vivo mediated by expression of wild type or mutant p53 proteins. *Cancer Res* 51, 5232-5237.
- Steegenga, W. T., Shvarts, A., Riteco, N., Bos, J. L., and Jochemsen, A. G. (1999). Distinct regulation of p53 and p73 activity by adenovirus E1A, E1B, and E4orf6 proteins. *Mol Cell Biol* 19, 3885-3894.
- Stiewe, T. (2007). The p53 family in differentiation and tumorigenesis. *Nat Rev Cancer* 7, 165-168.
- Stiewe, T., and Putzer, B. M. (2000). Role of the p53-homologue p73 in E2F1-induced apoptosis. *Nat Genet* 26, 464-469.
- Stiewe, T., and Putzer, B. M. (2002). Role of p73 in malignancy: tumor suppressor or oncogene? *Cell Death Differ* 9, 237-245.

- Stiewe, T., Stanelle, J., Theseling, C. C., Pollmeier, B., Beitzinger, M., and Putzer, B. M. (2003). Inactivation of retinoblastoma (RB) tumor suppressor by oncogenic isoforms of the p53 family member p73. *J Biol Chem* 278, 14230-14236.
- Stiewe, T., Theseling, C. C., and Putzer, B. M. (2002a). Transactivation-deficient Delta TA-p73 inhibits p53 by direct competition for DNA binding: implications for tumorigenesis. *J Biol Chem* 277, 14177-14185.
- Stiewe, T., Zimmermann, S., Frilling, A., Esche, H., and Putzer, B. M. (2002b). Transactivation-deficient DeltaTA-p73 acts as an oncogene. *Cancer Res* 62, 3598-3602.
- Strano, S., Munarriz, E., Rossi, M., Cristofanelli, B., Shaul, Y., Castagnoli, L., Levine, A. J., Sacchi, A., Cesareni, G., Oren, M., and Blandino, G. (2000). Physical and functional interaction between p53 mutants and different isoforms of p73. *J Biol Chem* 275, 29503-29512.
- Sun, X. F. (2002). p73 overexpression is a prognostic factor in patients with colorectal adenocarcinoma. *Clin Cancer Res* 8, 165-170.
- Sunahara, M., Ichimiya, S., Nimura, Y., Takada, N., Sakiyama, S., Sato, Y., Todo, S., Adachi, W., Amano, J., and Nakagawara, A. (1998). Mutational analysis of the p73 gene localized at chromosome 1p36.3 in colorectal carcinomas. *Int J Oncol* 13, 319-323.
- Tannapfel, A., Engeland, K., Weinans, L., Katalinic, A., Hauss, J., Mossner, J., and Wittekind, C. (1999a). Expression of p73, a novel protein related to the p53 tumour suppressor p53, and apoptosis in cholangiocellular carcinoma of the liver. *Br J Cancer* 80, 1069-1074.
- Tannapfel, A., Wasner, M., Krause, K., Geissler, F., Katalinic, A., Hauss, J., Mossner, J., Engeland, K., and Wittekind, C. (1999b). Expression of p73 and its relation to histopathology and prognosis in hepatocellular carcinoma. *J Natl Cancer Inst* 91, 1154-1158.
- Tokuchi, Y., Hashimoto, T., Kobayashi, Y., Hayashi, M., Nishida, K., Hayashi, S., Imai, K., Nakachi, K., Ishikawa, Y., Nakagawa, K., *et al.* (1999). The expression of p73 is increased in lung cancer, independent of p53 gene alteration. *Br J Cancer* 80, 1623-1629.
- Trink, B., Okami, K., Wu, L., Sriuranpong, V., Jen, J., and Sidransky, D. (1998). A new human p53 homologue. *Nat Med* 4, 747-748.
- Tsai, K. K., and Yuan, Z. M. (2003). c-Abl stabilizes p73 by a phosphorylation-augmented interaction. *Cancer Res* 63, 3418-3424.
- Tsao, H., Zhang, X., Majewski, P., and Haluska, F. G. (1999). Mutational and expression analysis of the p73 gene in melanoma cell lines. *Cancer Res* 59, 172-174.
- Ueda, Y., Hijikata, M., Takagi, S., Chiba, T., and Shimotohno, K. (1999). New p73 variants with altered C-terminal structures have varied transcriptional activities. *Oncogene* 18, 4993-4998.
- Ueda, Y., Hijikata, M., Takagi, S., Chiba, T., and Shimotohno, K. (2001). Transcriptional activities of p73 splicing variants are regulated by inter-variant association. *Biochem J* 356, 859-866.
- Unger, T., Nau, M. M., Segal, S., and Minna, J. D. (1992). p53: a transdominant regulator of transcription whose function is ablated by mutations occurring in human cancer. *EMBO J* 11, 1383-1390.

- van Bokhoven, H., Hamel, B. C., Bamshad, M., Sangiorgi, E., Gurrieri, F., Duijf, P. H., Vanmolkot, K. R., van Beusekom, E., van Beersum, S. E., Celli, J., *et al.* (2001). p63 Gene mutations in eec syndrome, limb-mammary syndrome, and isolated split hand-split foot malformation suggest a genotype-phenotype correlation. *Am J Hum Genet* 69, 481-492.
- Vikhanskaya, F., D'Incalci, M., and Broggin, M. (2000). p73 competes with p53 and attenuates its response in a human ovarian cancer cell line. *Nucleic Acids Res* 28, 513-519.
- Vikhanskaya, F., Marchini, S., Marabese, M., Galliera, E., and Broggin, M. (2001). P73a overexpression is associated with resistance to treatment with DNA-damaging agents in a human ovarian cancer cell line. *Cancer Res* 61, 935-938.
- Vossio, S., Palescandolo, E., Pediconi, N., Moretti, F., Balsano, C., Levrero, M., and Costanzo, A. (2002). DN-p73 is activated after DNA damage in a p53-dependent manner to regulate p53-induced cell cycle arrest. *Oncogene* 21, 3796-3803.
- Waltermann, A., Kartasheva, N. N., and Dobbelstein, M. (2003). Differential regulation of p63 and p73 expression. *Oncogene* 22, 5686-5693.
- Wang, X., Arooz, T., Siu, W. Y., Chiu, C. H., Lau, A., Yamashita, K., and Poon, R. Y. (2001a). MDM2 and MDMX can interact differently with ARF and members of the p53 family. *FEBS Lett* 490, 202-208.
- Wang, X. Q., Ongkeko, W. M., Lau, A. W., Leung, K. M., and Poon, R. Y. (2001b). A possible role of p73 on the modulation of p53 level through MDM2. *Cancer Res* 61, 1598-1603.
- Weber, A., Bellmann, U., Bootz, F., Wittekind, C., and Tannapfel, A. (2002). Expression of p53 and its homologues in primary and recurrent squamous cell carcinomas of the head and neck. *Int J Cancer* 99, 22-28.
- Westfall, M. D., and Pietenpol, J. A. (2004). p63: Molecular complexity in development and cancer. *Carcinogenesis* 25, 857-864.
- Wiman, K. G. (2006). Strategies for therapeutic targeting of the p53 pathway in cancer. *Cell Death Differ* 13, 921-926.
- Wong, S. W., Tiong, K. H., Kong, W. Y., Yue, Y. C., Chua, C. H., Lim, J. Y., Lee, C. Y., Quah, S. I., Fow, C., Chung, C., *et al.* (2010). Rapamycin synergizes cisplatin sensitivity in basal-like breast cancer cells through up-regulation of p73. *Breast Cancer Res Treat.*
- Wu, G., Nomoto, S., Hoque, M. O., Dracheva, T., Osada, M., Lee, C. C., Dong, S. M., Guo, Z., Benoit, N., Cohen, Y., *et al.* (2003). DeltaNp63alpha and TAp63alpha regulate transcription of genes with distinct biological functions in cancer and development. *Cancer Res* 63, 2351-2357.
- Yamaguchi, K., Wu, L., Caballero, O. L., Hibi, K., Trink, B., Resto, V., Cairns, P., Okami, K., Koch, W. M., Sidransky, D., and Jen, J. (2000). Frequent gain of the p40/p51/p63 gene locus in primary head and neck squamous cell carcinoma. *Int J Cancer* 86, 684-689.
- Yang, A., Kaghad, M., Wang, Y., Gillett, E., Fleming, M. D., Dotsch, V., Andrews, N. C., Caput, D., and McKeon, F. (1998). p63, a p53 homolog at 3q27-29, encodes multiple products with transactivating, death-inducing, and dominant-negative activities. *Mol Cell* 2, 305-316.

- Yang, A., Schweitzer, R., Sun, D., Kaghad, M., Walker, N., Bronson, R. T., Tabin, C., Sharpe, A., Caput, D., Crum, C., and McKeon, F. (1999). p63 is essential for regenerative proliferation in limb, craniofacial and epithelial development. *Nature* 398, 714-718.
- Yang, A., Walker, N., Bronson, R., Kaghad, M., Oosterwegel, M., Bonnin, J., Vagner, C., Bonnet, H., Dikkes, P., Sharpe, A., *et al.* (2000). p73-deficient mice have neurological, pheromonal and inflammatory defects but lack spontaneous tumours. *Nature* 404, 99-103.
- Yew, P. R., and Berk, A. J. (1992). Inhibition of p53 transactivation required for transformation by adenovirus early 1B protein. *Nature* 357, 82-85.
- Yokomizo, A., Mai, M., Tindall, D. J., Cheng, L., Bostwick, D. G., Naito, S., Smith, D. I., and Liu, W. (1999). Overexpression of the wild type p73 gene in human bladder cancer. *Oncogene* 18, 1629-1633.
- Yu, J., Zhang, L., Hwang, P. M., Rago, C., Kinzler, K. W., and Vogelstein, B. (1999). Identification and classification of p53-regulated genes. *Proc Natl Acad Sci U S A* 96, 14517-14522.
- Yuan, Z. M., Shioya, H., Ishiko, T., Sun, X., Gu, J., Huang, Y. Y., Lu, H., Kharbanda, S., Weichselbaum, R., and Kufe, D. (1999). p73 is regulated by tyrosine kinase c-Abl in the apoptotic response to DNA damage. *Nature* 399, 814-817.
- Zaika, A., Irwin, M., Sansome, C., and Moll, U. M. (2001). Oncogenes induce and activate endogenous p73 protein. *J Biol Chem* 276, 11310-11316.
- Zaika, A. I., and El-Rifai, W. (2006). The role of p53 protein family in gastrointestinal malignancies. *Cell Death Differ* 13, 935-940.
- Zaika, A. I., Kovalev, S., Marchenko, N. D., and Moll, U. M. (1999). Overexpression of the wild type p73 gene in breast cancer tissues and cell lines. *Cancer Res* 59, 3257-3263.
- Zaika, A. I., Slade, N., Erster, S. H., Sansome, C., Joseph, T. W., Pearl, M., Chalas, E., and Moll, U. M. (2002). DeltaNp73, a dominant-negative inhibitor of wild-type p53 and TAp73, is up-regulated in human tumors. *J Exp Med* 196, 765-780.
- Zeng, X., Chen, L., Jost, C. A., Maya, R., Keller, D., Wang, X., Kaelin, W. G., Jr., Oren, M., Chen, J., and Lu, H. (1999). MDM2 suppresses p73 function without promoting p73 degradation. *Mol Cell Biol* 19, 3257-3266.
- Zeng, X., Li, X., Miller, A., Yuan, Z., Yuan, W., Kwok, R. P., Goodman, R., and Lu, H. (2000). The N-terminal domain of p73 interacts with the CH1 domain of p300/CREB binding protein and mediates transcriptional activation and apoptosis. *Mol Cell Biol* 20, 1299-1310.
- Zheng, X., and Chen, X. (2001). Aquaporin 3, a glycerol and water transporter, is regulated by p73 of the p53 family. *FEBS Lett* 489, 4-7.
- Zhu, J., Jiang, J., Zhou, W., and Chen, X. (1998). The potential tumor suppressor p73 differentially regulates cellular p53 target genes. *Cancer Res* 58, 5061-5065.
- Zwahlen, D., Tschan, M. P., Grob, T. J., Peters, U. R., Fink, D., Haenggi, W., Altermatt, H. J., Cajot, J. F., Tobler, A., Fey, M. F., and Aebi, S. (2000). Differential expression of p73 splice variants and protein in benign and malignant ovarian tumours. *Int J Cancer* 88, 66-70.

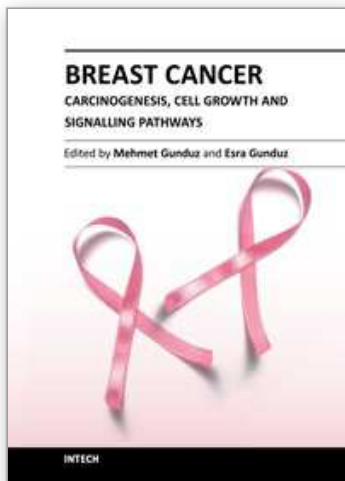

Breast Cancer - Carcinogenesis, Cell Growth and Signalling Pathways

Edited by Prof. Mehmet Gunduz

ISBN 978-953-307-714-7

Hard cover, 732 pages

Publisher InTech

Published online 30, November, 2011

Published in print edition November, 2011

Cancer is the leading cause of death in most countries and its consequences result in huge economic, social and psychological burden. Breast cancer is the most frequently diagnosed cancer type and the leading cause of cancer death among females. In this book, we discussed various aspects of breast cancer carcinogenesis from clinics to its hormone-based as well as genetic-based etiologies for this deadly cancer. We hope that this book will contribute to the development of novel diagnostic as well as therapeutic approaches.

How to reference

In order to correctly reference this scholarly work, feel free to copy and paste the following:

Chee-Onn Leong (2011). p53, p63 and p73 Network in Breast Cancers, Breast Cancer - Carcinogenesis, Cell Growth and Signalling Pathways, Prof. Mehmet Gunduz (Ed.), ISBN: 978-953-307-714-7, InTech, Available from: <http://www.intechopen.com/books/breast-cancer-carcinogenesis-cell-growth-and-signalling-pathways/p53-p63-and-p73-network-in-breast-cancers>

INTECH
open science | open minds

InTech Europe

University Campus STeP Ri
Slavka Krautzeka 83/A
51000 Rijeka, Croatia
Phone: +385 (51) 770 447
Fax: +385 (51) 686 166
www.intechopen.com

InTech China

Unit 405, Office Block, Hotel Equatorial Shanghai
No.65, Yan An Road (West), Shanghai, 200040, China
中国上海市延安西路65号上海国际贵都大饭店办公楼405单元
Phone: +86-21-62489820
Fax: +86-21-62489821

© 2011 The Author(s). Licensee IntechOpen. This is an open access article distributed under the terms of the [Creative Commons Attribution 3.0 License](#), which permits unrestricted use, distribution, and reproduction in any medium, provided the original work is properly cited.

IntechOpen

IntechOpen