

# We are IntechOpen, the world's leading publisher of Open Access books Built by scientists, for scientists

4,800

Open access books available

122,000

International authors and editors

135M

Downloads

Our authors are among the

154

Countries delivered to

TOP 1%

most cited scientists

12.2%

Contributors from top 500 universities



WEB OF SCIENCE™

Selection of our books indexed in the Book Citation Index  
in Web of Science™ Core Collection (BKCI)

Interested in publishing with us?  
Contact [book.department@intechopen.com](mailto:book.department@intechopen.com)

Numbers displayed above are based on latest data collected.  
For more information visit [www.intechopen.com](http://www.intechopen.com)



# Environmental Background Radiation Monitoring Utilizing Passive Solid State Dosimeters

Hidehito Nanto<sup>1,2</sup>, Yoshinori Takei<sup>1,2</sup> and Yuka Miyamoto<sup>2,3</sup>

<sup>1</sup>*Advanced Materials Science R&D Center,*

<sup>2</sup>*Research Laboratory for Integrated Technological Systems,  
Kanazawa Institute of Technology, Hakusan, Ishikawa,*

<sup>3</sup>*Oarai Research Center, Chiyoda Technol Corporation, Oarai-machi, Higashi Ibaragi,  
Japan*

## 1. Introduction

Natural environmental background radiation is radiation that is constantly present in the environment and is emitted from a variety of natural and artificial sources. Primary contribution comes from sources in the earth, from space and in the atmosphere. Naturally occurring sources are responsible for the vast majority of radiation exposure. However, not including direct exposure from radiological imaging or therapy, about 3% of background radiation comes from man-made sources such as self-luminous dials and signs, global radioactive contamination due to historical nuclear weapons testing, nuclear power station or nuclear fuel reprocessing accidents, normal operation of facilities used for nuclear power and scientific research, emission from burning fossil fuels and emission from nuclear medicine facilities and patients.

We are all exposed to ionizing radiation every day. In fact, the environmental background radiation contributes about two-thirds of our radiation exposure. Therefore, it is important to determine the exact environmental background radiation dose. Active dosimeters have been formally appropriate for monitoring dose equivalent rates of environmental background radiation. On 2001 in Japan, not only dose equivalent rate but also dose equivalent can be applied to environmental background radiation monitoring, which is based on the Japanese law modification concerned with radiation protection. Thus, there is the possibility that passive solid state dosimeters are also appropriate for environmental background radiation monitoring.

So far, some types of solid state dosimeter have been developed not only for personal monitoring but also for environmental background radiation monitoring. For instance, a thermoluminescence (TL) dosimeter has been studied to monitor the environmental background radiation (Nanto, 2011). Recently newly passive solid state dosimeters utilizing optically stimulated luminescence (OSL), direct ion storage (DIS) and radiophotoluminescence (RPL) phenomena have been developed to monitor the personal and environmental radiation (Ranogajec-Komor, 2008; Koyama, 2010).

In the following, the basic principle of the passive solid state dosimeters utilizing TL, OSL, DIS and RPL phenomenon are reviewed and the results on environmental background

monitoring using these passive dosimeters, especially personal dosimeter utilizing RPL phenomenon, are shown and discussed.

## 2. Passive solid state dosimeters

Active dosimeters have been formally appropriate for monitoring dose equivalent rates of environmental natural radiation. In 2001, not only dose equivalent rate but also dose equivalent can become applied to environmental natural radiation monitoring; the dose equivalents at the boundary of the controlled area and the area is limited to be less than or equals to 1.3 mSv/3 months. Thus, there is the possibility that passive dosimeters are also appropriate for the environmental natural radiation monitoring. An application of various kinds of passive dosimeters, especially the dosimeter utilizing TL phenomenon (TL dosimeter), has been studied to monitoring the environmental natural radiation (Saez-Vergara, 1999). Recently, new passive dosimeters such as the dosimeter utilizing OSL phenomenon (OSL dosimeter), the dosimeter utilizing DIS phenomenon (DIS dosimeter) and the glass dosimeter utilizing RPL phenomenon (RPL glass dosimeter) have been developed as the personal dosimeter. In this study, the RPL glass dosimeters as well as the OSL dosimeter and the DIS dosimeter has been applied to monitor the environmental natural background radiation .

### 2.1 Operation principle of the solid state dosimeters

In this section, the operation principle of the solid state dosimeters, such as RPL glass dosimeter, the OSL dosimeter and the DIS dosimeter are discussed.

#### 2.1.1 Glass dosimeters

$\text{Ag}^+$ -doped phosphate glass after exposure to ionizing radiation has an intense luminescence by the excitation with ultraviolet light. This phenomenon is called radiophotoluminescence (RPL). When  $\text{Ag}^+$ -doped phosphate glass is exposed to ionizing radiation, electron and hole pairs are produced. The electrons are captured by the  $\text{Ag}^+$  ions in the glass structure, and

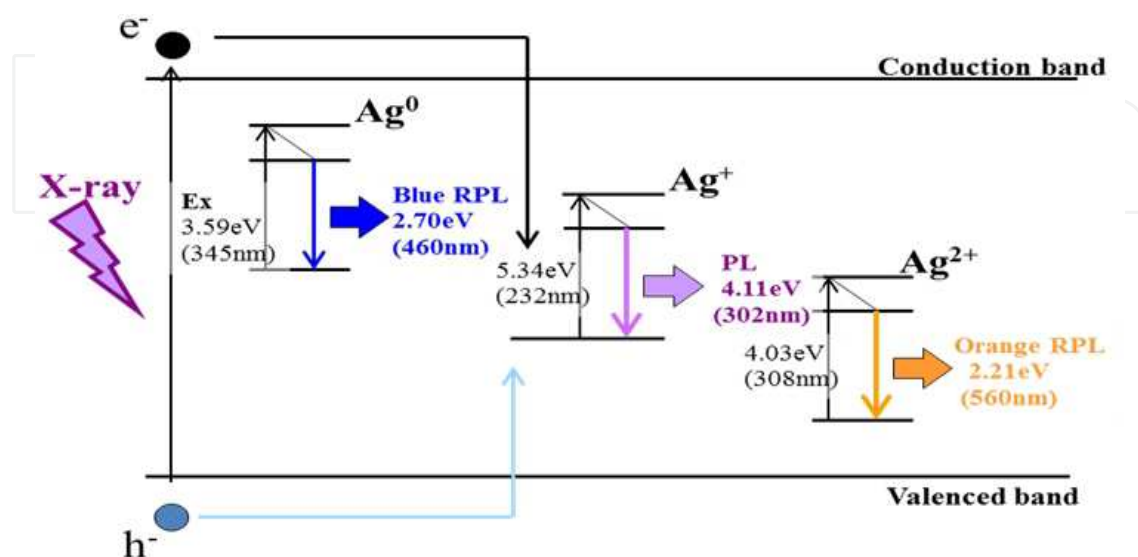

Fig. 1. Energy band diagram for RPL centers in  $\text{Ag}^+$ -doped phosphate glass.

then  $\text{Ag}^+$  ions change to  $\text{Ag}^0$  ions. On the other hand, the holes are captured initially by  $\text{PO}_4$  tetrahedra and then migrate to produce  $\text{Ag}^{2+}$  ions. It has been reported (Miyamoto, 2011) that both  $\text{Ag}^0$  and  $\text{Ag}^{2+}$  ions can be the centers of luminescence in the phosphate glass as shown in Fig.1. Moreover, once trapped, luminescence centers are stable unless the glasses are annealed at high temperature at about  $400^\circ\text{C}$ . Figure 2 shows photograph of orange RPL from the glass dosimeter which was exposed to x-ray. As the RPL intensity is proportional to the amount of irradiation, the  $\text{Ag}^+$ -doped phosphate glass can be used in individual monitoring of ionizing radiation.

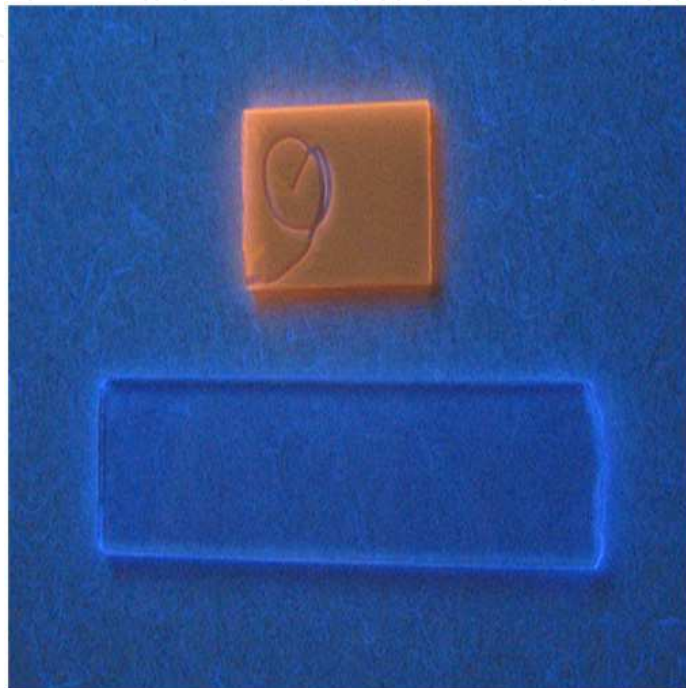

Fig. 2. Photographs of emitted RPL from the glass dosimeter which was exposed to x-ray (upper photograph) and without x-ray irradiation (down photograph).

### 2.1.2 OSL dosimeters

The OSL process as well as TL process is based on the presence of electron and/or hole traps and luminescence centers in storage phosphor materials (Nanto, 1998). Figure 3 shows the energy band diagram of Eu doped BaFBrI (BaFBrI:Eu) photostimulable storage phosphor which is used as the storage phosphor material of the imaging plate (IP) (Nanto, H. 2006) for the computed radiography. Upon irradiation with ionizing radiation such as x-ray to storage phosphor materials, free electrons in conduction band (C.B.) and holes in valenced band (V.B.) are promoted via band-to-band excitation. The free electrons are, then, trapped at anion vacancies such as F, I and Br vacancies to produce the F centers as the electron trap centers. While the free holes are trapped at the  $\text{Eu}^{2+}$  impurity centers to produce the  $\text{Eu}^{3+}$  impurity centers. Detrapping of these carriers requires energy.

In OSL process, the energy is provided by stimulating the phosphor materials with visible or near infrared light after irradiation. During a detrapping transition, free electrons stimulated from the F centers into the conduction band recombine with the luminescence centers of the  $\text{Eu}^{3+}$  ions, whereby visible photons (OSL) are emitted as shown in Fig.3.

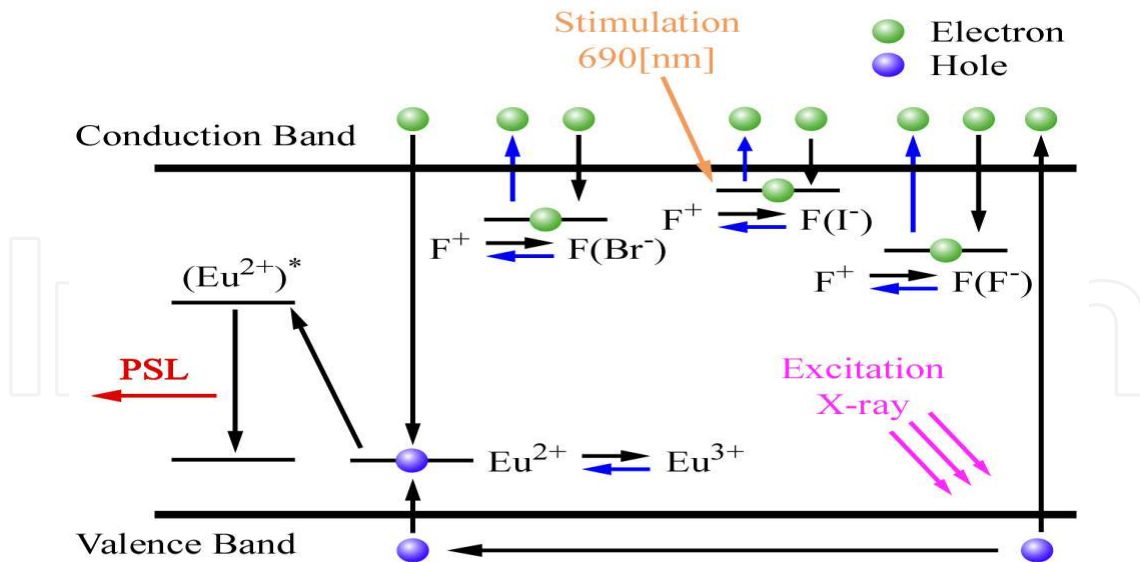

Fig. 3. Energy band diagram for OSL process in BaFBr:Eu phosphor.

In TL process the energy is provided by heating the phosphor materials. Since the OSL intensity as well as TL intensity is proportional to x-ray dose, the phosphor materials which exhibit the OSL or TL phenomenon offer an alternative to conventional x-ray film (Nanto, 1999). Figure 4 shows typical OSL spectra and their stimulation spectra of various IPs. In all IPs, the OSL peaked at about 400 - 450 nm is observed by stimulating with about 550-650 nm light. The OSL phenomena can, therefore, be applied to the computed radiography using IP with BaFBr:Eu phosphor materials as well as to individual radiation monitoring and environmental monitoring using LiF:Mg (Saez-Vergara, 1999) TL dosimeters or  $\text{Al}_2\text{O}_3\text{:C}$  OSL dosimeter (Sarai, 2004). The OSL of the Luxel badge using  $\text{Al}_2\text{O}_3\text{:C}$  photostimulable phosphor can be observed at about 420 nm by stimulating with about 520 nm light.

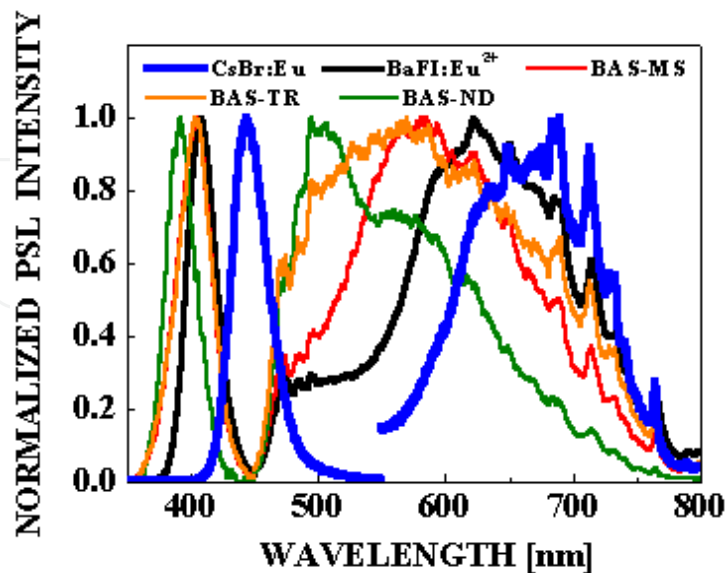

Fig. 4. OSL spectra and its stimulation (excitation) spectra of various imaging plates. Here, the IP, type-BAS-MS using BaFBr:Eu photostimulable phosphor is commercially available from Fuji Film Corp.

### 2.1.3 DIS dosimeters

The DIS dosimeter is composed of metal-oxide-semiconductor field effect transistor (MOSFET) with ionizing chamber (Wernli, 1998) as shown in Fig.5. The basic principle of the DIS dosimeter is as follows; a nonvolatile solid state memory cell is stored in the form of electric charge being trapped on the floating gate of a MOSFET in air or gas space surrounded by a conductive wall. The DIS dosimeter (Type DIS-1) which responds to X,  $\gamma$  and  $\beta$ -rays (Kobayashi, 2004) can widely detect a radiation dose within the range from 1 to 40 [ $\mu$ Sv].

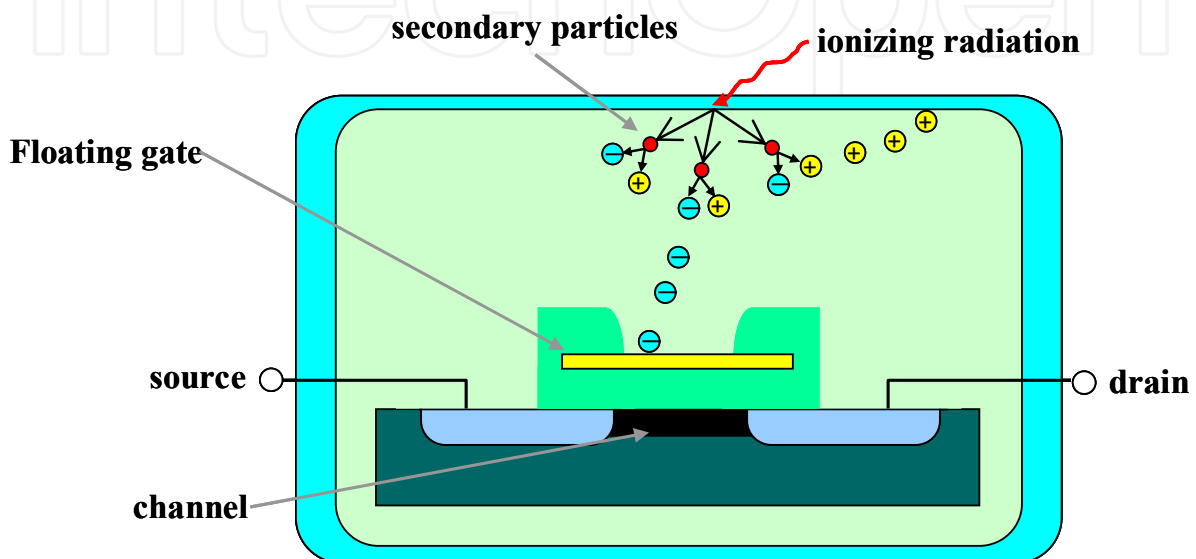

Fig. 5. Schematic diagram of the DIS dosimeter

### 2.2 Comparison of features of each solid state dosimeter

The comparison of various basic characteristics, such as the readout process, the sensitivity for x-ray,  $\beta$ -ray and neutron, the energy dependence, of each solid state dosimeter is shown in Table 1. We would like to emphasize here is that the RPL glass dosimeter has good fading characteristics which means the luminescence centers are stable at room temperature unless the glasses are annealed at high temperature at about 400°C.

Phenomenon (Materials)	Readout	Sensitivity	Energy Dependence	Fading
RPL (Phosphate glass)	Excitation with UV light	0.1 - 10,000 [mSv]	10keV ~ 10MeV (x-ray, $\gamma$ ray), 300keV ~ 3MeV ( $\beta$ ray) 0.025eV-15MeV (Neutron)	Excellent
OSL ( $\text{Al}_2\text{O}_3\text{:C}$ , $\text{BaFBr:Eu}$ , $\text{KCl:Eu}$ )	Excitation with visible light	0.01 [mSv] - 10 [Sv] (X $\cdot$ $\gamma$ -ray) 0.01 [mSv] - 10 [Sv] ( $\beta$ -ray) 0.1 [mSv] - 6 [mSv] (Neutron)	5keV ~ 10MeV (X $\cdot$ $\gamma$ -ray) 150keV ~ 10MeV ( $\beta$ -ray) 0.025eV ~ 0.5eV (Neutron)	OK
Ionization of air (Si -MOSFET)	Electrical signal	1 ~ 40 [ $\mu$ Sv]	6keV - 9 MeV (X $\cdot$ $\gamma$ -ray) 0.06 - 0.8 MeV ( $\beta$ -ray)	Good

Table 1. Basic characteristics of each solid state dosimeter

### 3. Experimental

The RPL glass dosimeter, the OSL dosimeter and the DIS dosimeter developed as the passive dosimeter were used in the environmental natural radiation monitoring. Figure 6 shows photographs of a personal glass dosimeter of type GD-450 used in this study. The GD-450 is made of  $\text{Ag}^+$ -doped phosphate glass (AGC Techno Glass Co., Ltd.), supplied by Chiyoda Technol Corp.

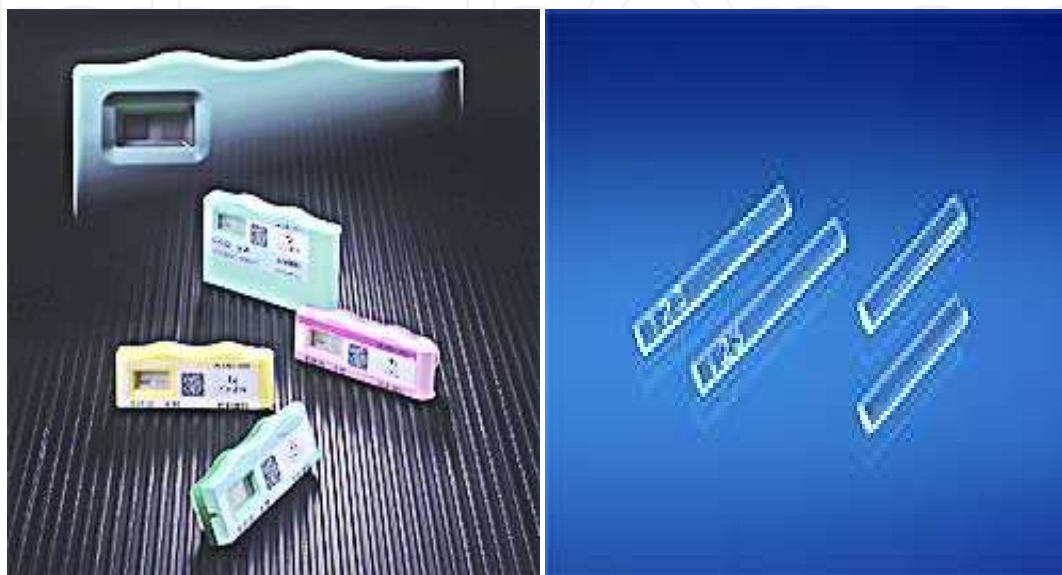

Fig. 6. Photographs of the GD-450 (left) and of glass used in GD-450 (right).

The OSL dosimeters (Luxel badge: S-type) used in this study as shown in Fig.7 (left) were supplied by Nagase Landauer Co., Ltd. (Kobayashi, 2004). In this study, the OSL dosimeter, which was made of an  $\text{Al}_2\text{O}_3:\text{C}$  phosphor material, was used for environmental natural radiation monitoring. The  $\text{Al}_2\text{O}_3:\text{C}$  phosphor emit 420 nm OSL emission with intensity in proportion to the exposure dose under optical stimulation with the wavelength of 523 nm.



Fig. 7. Photographs of the OSL dosimeter (Type S) as shown the left photo picture and of the DIS dosimeter (Type DIS-1) as shown in the right photo picture.

The DIS as shown in Fig.7 (right) was supplied from RADOS Technology, Finland. The basic principle of the DIS is as follows; a nonvolatile solid-state memory cell is stored in the form of electric charge being trapped on the floating gate of a MOSFET transistor in air or gas space surrounded by a conductive wall. The DIS dosimeter is based on Analog-EEPROM (Analog Electrically Erasable Programmable Read Only Memory). The DIS responds to X,  $\gamma$ ,  $\beta$ -rays and neutron. This dosimeter has an excellent energy characteristic and can be read repeatedly without quenching of the data. The DIS dosimeter can widely detect a radiation dose within the range from 1  $\mu$ Sv to 40 Sv

The personal dosimeters GD-450, Luxel badge (Type S) and DIS-1 were set on 7 points in Ishikawa prefecture as shown in Fig.8.

Each of 7 points are represented as alphabet of from A to G. (A: Tsurugi-machi, B: Tatsunokuchi, C: Inside of house of Mt. Shishiku, D: Outside of Mt. shishiku, E: Inside of Ogoya Mines, F: Outside of Ogoya Mines, G: Public Health and Environmental Science). Each data was obtained monthly. Photographs of local points in which the dosimeters were set up are shown in Fig.9. Data were obtained monthly. The each accumulated monthly data was divided into daily data and multiplied 30 days. The each data was compensated appropriately with the each formula for the dosimeters (Sarai, 2004). The same point data were averaged and the standard deviations were calculated. The data of GD-450 were compared with the data of the other dosimeters.

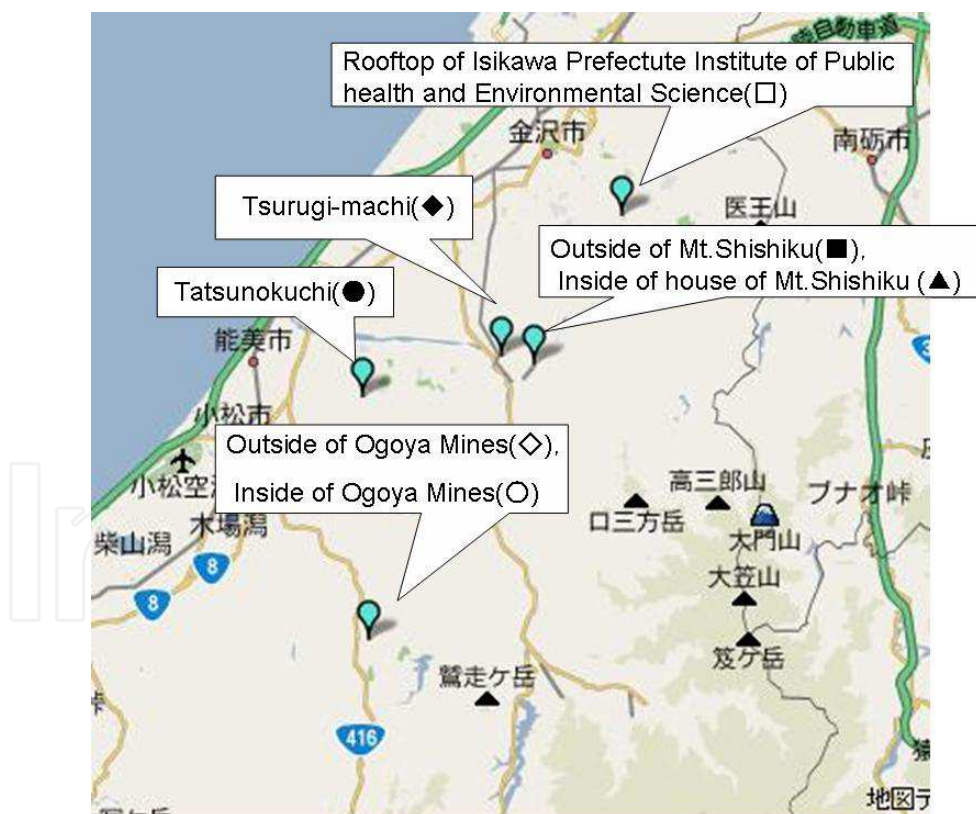

Fig. 8. Map of seven points such as Tsurugi-machi (◆), Tatsunokuchi (●), outside of Mt. Shishiku (■), inside of house in Mt. Shishiku (▲), outside of Ogoya Mines (◇), Inside of Ogoya Mines (○) and rooftop of Ishikawa Prefecture Institute of Public Health and Environmental Science (□). in Ishikawa prefecture, in which the environmental radiation dose using the glass dosimeter were measured.



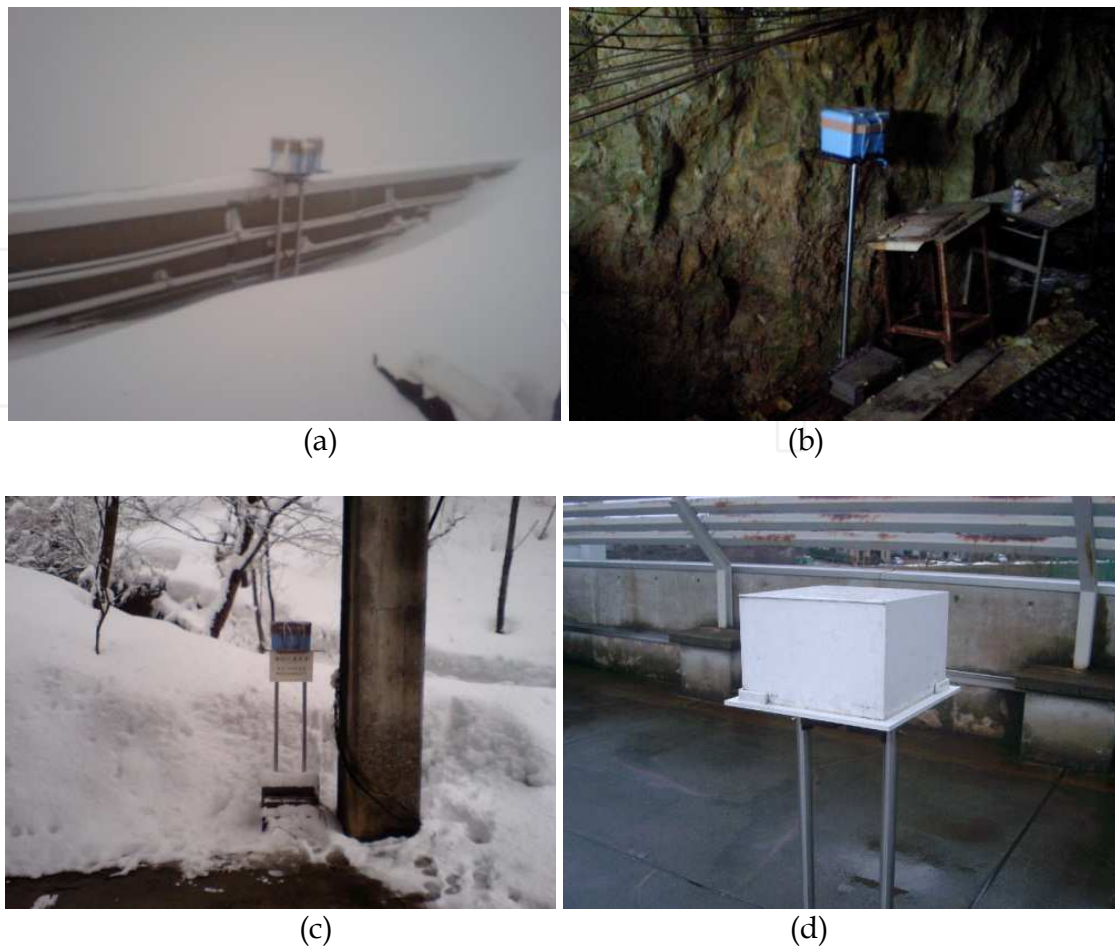

Fig. 9. Photographs of 4 points such as (a) point D, (b) point E, (c) point F and (d) point G in Ishikawa prefecture, in which the dosimeters were set up.

## 4. Results and discussion

### 4.1 Basic characteristics of RPL glass dosimeter

Typical RPL emission and its excitation spectra of x-ray irradiated Ag<sup>+</sup>-doped phosphate glass are shown in Fig.10. It can be seen that the RPL emission spectrum consists of two emission bands peaked at about 2.70 eV (460 nm) and 2.21 eV (560 nm). On the other hand, the RPL excitation spectrum consists of two excitation bands peaked at about 3.93 eV (315 nm) and 3.32 eV (373 nm). The fact that RPL emission spectrum consists of two emission bands such as yellow color emission and blue color emission has been reported in previous report (Miyamoto, 2010). The radiative lifetime of yellow and blue RPL peaks are estimated. The lifetime is 2~4 μs for yellow RPL and 2~10 ns for blue RPL, respectively, which was dependent on the irradiation dose (Kurobori, 2010). The RPL emission mechanism is explained using Fig.11 as follows; when the Ag<sup>+</sup>-doped phosphate glass is exposed to ionizing radiation such as x-ray, the electron-hole pair will be produced. The electrons are captured into Ag<sup>+</sup> ions in the glass structure and then the Ag<sup>+</sup> ions change to Ag<sup>0</sup> ions. On the other hand, the holes are captured by the PO<sub>4</sub> tetrahedron at the beginning of migration and then produce Ag<sup>2+</sup> ions owing to interaction with Ag<sup>+</sup> ions over time. It has been reported that both Ag<sup>0</sup> and Ag<sup>2+</sup> ions can be played in role as luminescence centers for blue and yellow RPL, respectively (Miyamoto, 2010).

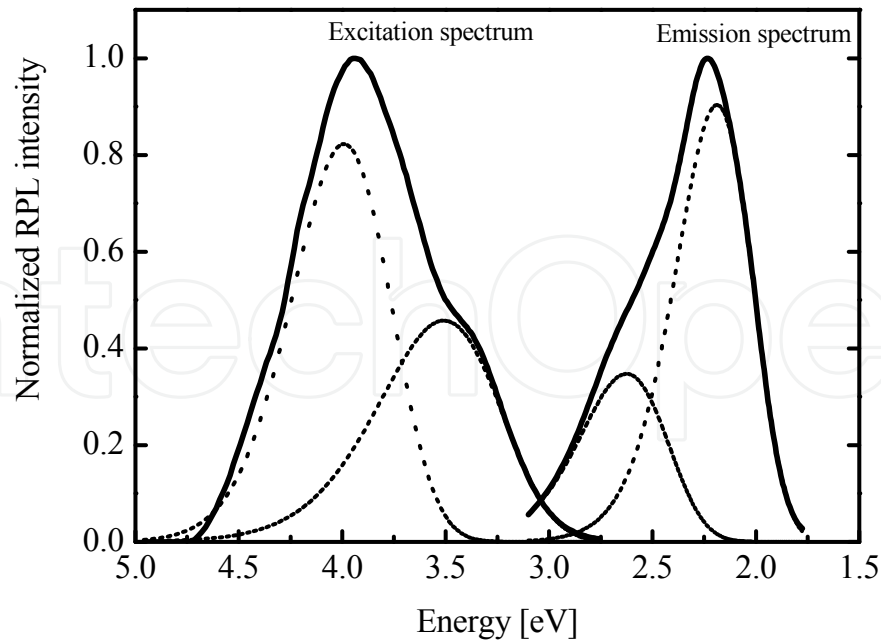

Fig. 10. Typical RPL emission and excitation spectra of  $\text{Ag}^+$ -doped phosphate glass after x-ray irradiation. The peak separation of the excitation and emission spectra of RPL indicated using dashed lines were carried out using the component separation of Gaussian bands(dashed lines).

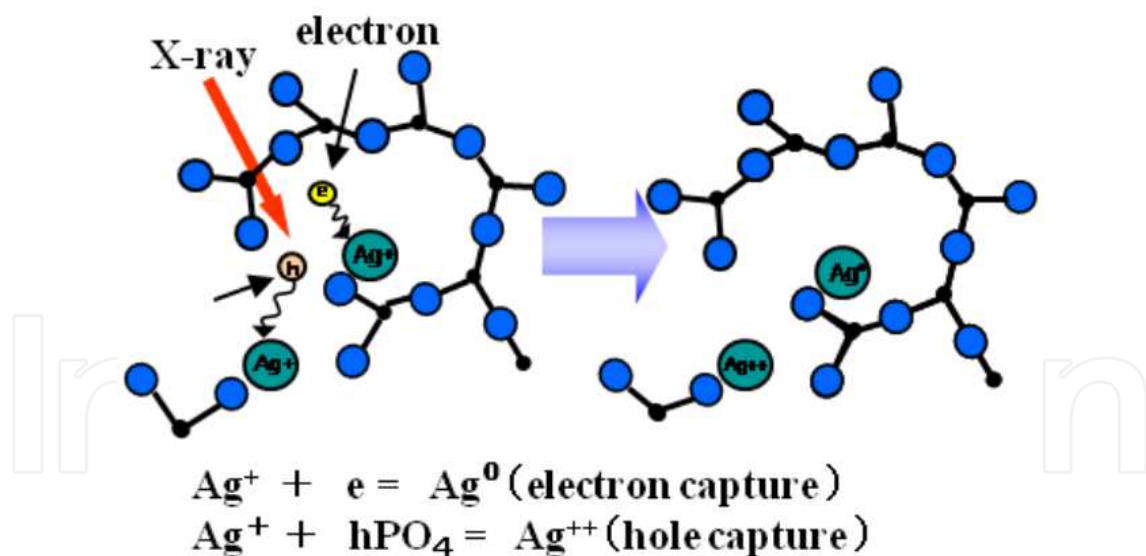

Fig. 11. Formation of RPL luminescence centers such as  $\text{Ag}^0$  and  $\text{Ag}^{2+}$  ions in x-ray irradiated  $\text{Ag}^+$ -doped phosphate glass.

The RPL emission images as a function of x-ray absorbed dose, when the x-ray irradiated  $\text{Ag}^+$ -doped phosphate glass is excited using UV light, are shown in Fig. 12, where it is seen that the intensity of yellow color emission increases with the absorbed dose. This result coincides with that of previous report (Shih-Ming Hsu, 2007), in which RPL intensity was almost linearly increased with x-ray absorption dose up to 10 Gy.

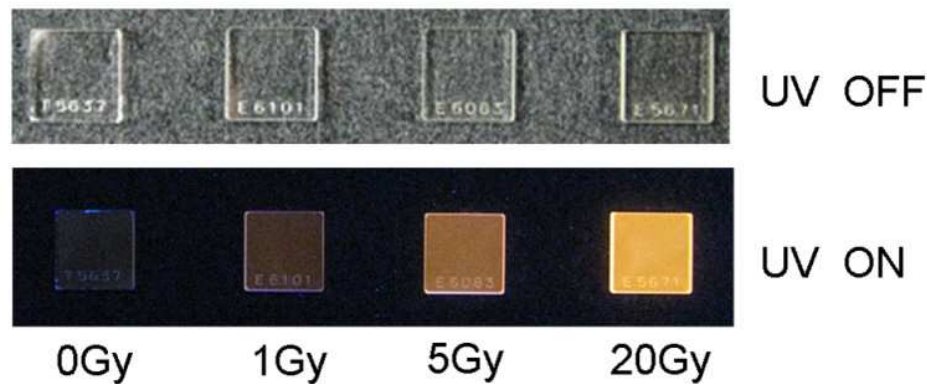

Fig. 12. RPL emission images of Ag<sup>+</sup>-doped phosphate glass as a function of x-ray absorbed dose : (a) Ag<sup>+</sup>-doped phosphate glass under visible light, (b) Ag<sup>+</sup>-doped phosphate glass under UV light.

#### 4.2 Results of environmental natural background radiation monitoring

Before the environmental background radiation monitoring was carried out, the self dose measurement and radioactive nuclide identification were made in an extremely low level background field of the tunnel of Ogoya Copper Mine (Ogoya underground laboratory of Kanazawa University), where muon intensity of cosmic ray is reduced to two orders of magnitude in comparison with the ground (Murata, 2002). The Luxel badge and DIS dosimeter were set in a shielding box of an ancient lead which contains few <sup>210</sup>Pb isotope (half-life 22.3 years). Five units of the Luxel badge and the DIS dosimeter were prepared to measure the self-doses. Self-doses were measured by the month during three months.

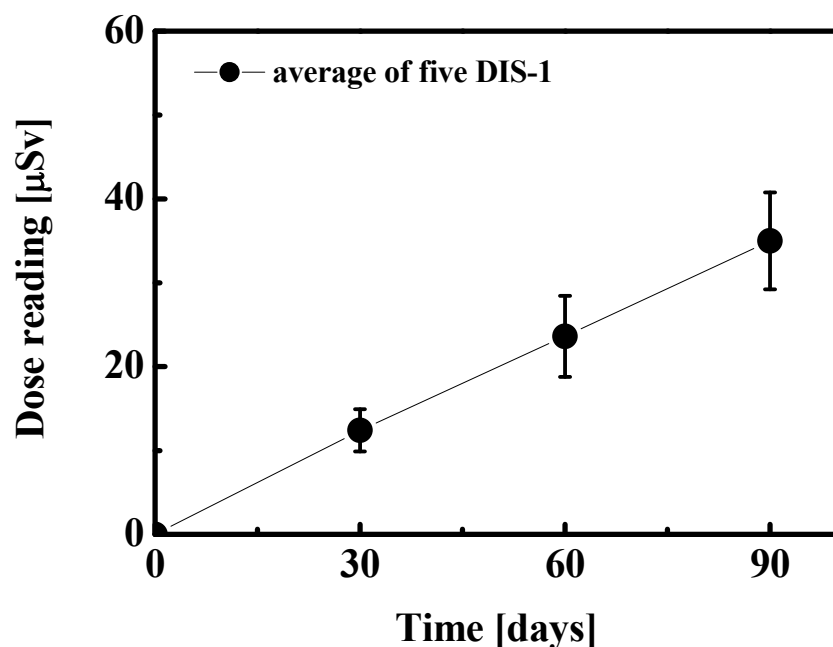

Fig. 13. Self-dose of the DIS-1 dosimeter. Each data point is averaged over doses of five DIS units

Figure 13 shows self-dose of the DIS dosimeter. The average self-dose accumulated in the DIS dosimeter increases almost linearly with increasing time. The average self-dose of the DIS

dosimeter within a month was estimated to be about  $12 \mu\text{Sv}$ . On the other hand, the averaged self-doses accumulated in the Luxel badge also increase linearly with increasing time except for the beginning of measurement as shown in Fig.14. The value at the beginning of measurement is different from the other two values. This deviation may be caused by the exposure to the natural radiation during the transportation of dosimeters to Nagase Landauer in Tokyo by air. Except for the data point at the beginning of measurement, the averaged self-dose of the Luxel Badge is estimated to be about  $9 \mu\text{Sv}$ .

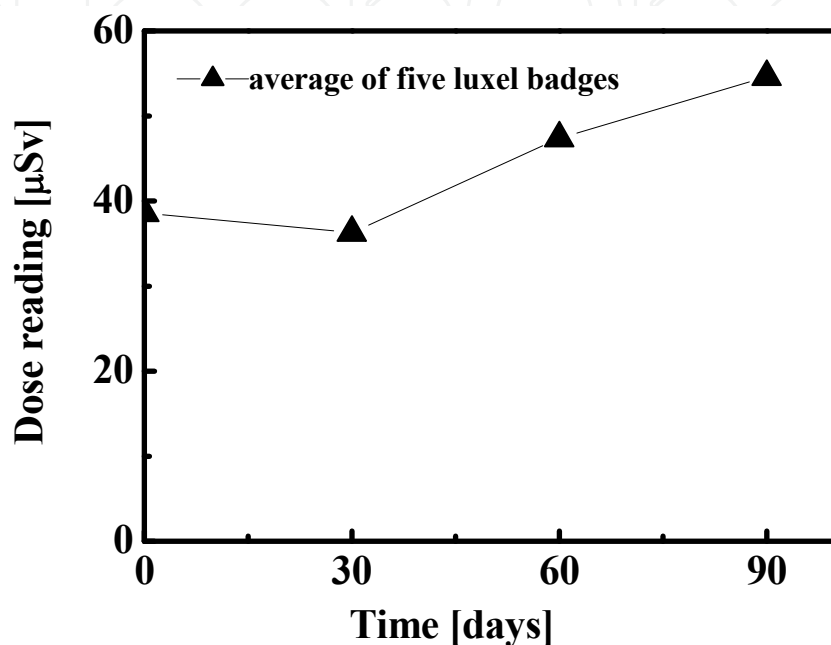

Fig. 14. Self-dose of the luxel badge dosimeter. Each data point is averaged over doses of three Luxel badge units.

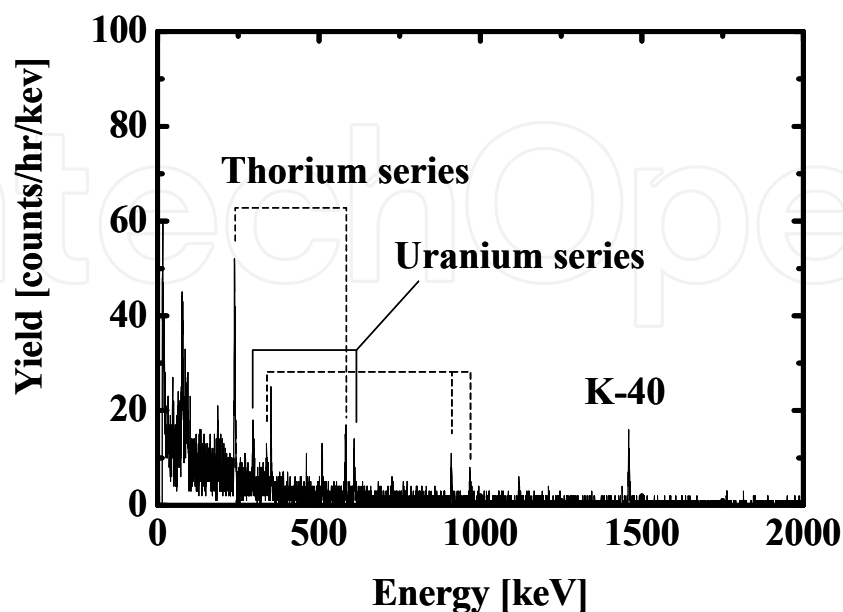

Fig. 15. Typical  $\gamma$ -ray spectrum obtained from the DIS dosimeter.

The origin of the self-dose was identified using high pure Ge semiconductor detector in the Ogoya underground laboratory. Typical gamma-ray spectrum obtained from the DIS dosimeter is shown in Fig.15.

dosimeter	parts	$^{238}\text{U}$ (dpm)	$^{210}\text{Pb}$ (dpm)	$^{232}\text{Th}$ (dpm)	$^{40}\text{K}$ (dpm)
DIS	Whole DIS	1.40		2.00	22.0
	Label				0.38
	Spring	0.88			
	Al frame	0.10			0.75
	IC long	1.30		1.50	
	IC fat	0.83		0.85	
	Battery	0.10			
Luxel	$\text{Al}_2\text{O}_3$ crystal	2.00		1.50	
	Ag filter				
	Sn filter	0.07	1.70	0.04	5.53

Table 2. Identified radioactive nuclides contained in each personal dosimeters.

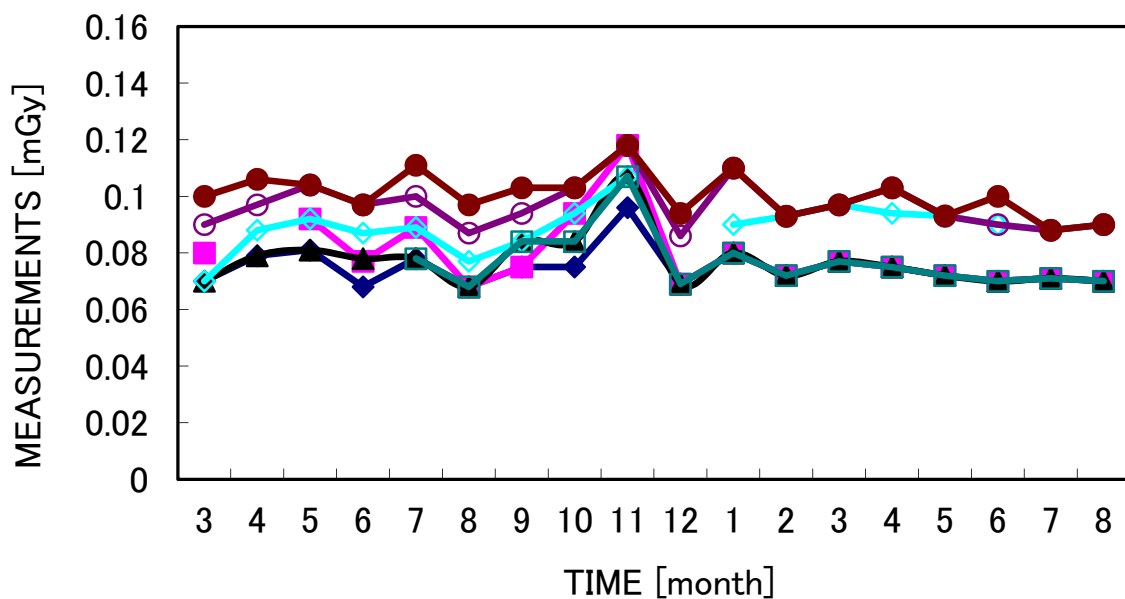

Fig. 16. Measured environmental radiation dose using the GD-450 glass dosimeter in seven points such as Tsurugi-machi (◆), Tatsunokuchi (●), outside of Mt.Shishiku (■), inside of house in Mt.Shishiku, (▲), outside of Ogoya Mines (◇), Inside of Ogoya Mines (○) and rooftop of Ishikawa Prefecture Institute of Public health and Environmental Science (□). in Ishikawa prefecture. The measurements of environmental radiation dose were carried out from March in 2008 to August 2009.

The several peaks under 1000 keV correspond to nuclides of  $^{232}\text{Th}$  and  $^{238}\text{U}$  series. The  $^{40}\text{K}$  peak with the energy of 1460 eV has been also detected. Measured parts and identified

radioactive nuclies are listed in Table 2. The  $^{40}\text{K}$ ,  $^{232}\text{Th}$  and  $^{238}\text{U}$  have been contained in almost all dosimeters. So, it is difined that the self-dose of each dosimeter for a month is about 10-15  $\mu\text{Sv}$ . Data was, therefore, compensated for each dosimeter which based on the sel-dose rate of about 12  $\mu\text{Sv}/\text{month}$ .

The environmental background radiation dose at 7 points for one month were monitored using the glass dosimeter (GD-450) as well as the Luxel badge and the DIS dosimeters. The monitoring results of typical environmental background radiation dose in gray (Gy) as the absorbed dose using the GD-450 from March in 2008 to August 2009 are shown in Fig.16 for 7 points in Ishikawa prefecture.

Although natural background radiation doses with the GD-450 dosimeter at each point in Ishikawa prefecture were significantly different, the standard deviations were very small. Although the values were a little bit different between the GD-450 glass dosimeter and the Luxel badge (OSL dosimeter), the tendencies of the environmental dose at each point were very similar as shown in Fig.17. The higher dose at point B (Tatsunokuchi) than at other points is due to the use of radioisotopes at the Lower Level Radiation laboratory in Kanazawa University. Moreover, the values of the GD-450 dosimeter and the DIS dosimeter were very close and there was no significant difference between them as shown Fig.18. We have made the comparison of different types of RPL glass dosimeters such as Type: GD-450 for personal dosimeter and Type:SC-1 for enviromental monitoring, which were supplied from Chiyoda Technol Corp, as shown in Fig.19. It was found that there is no significant difference at each points.

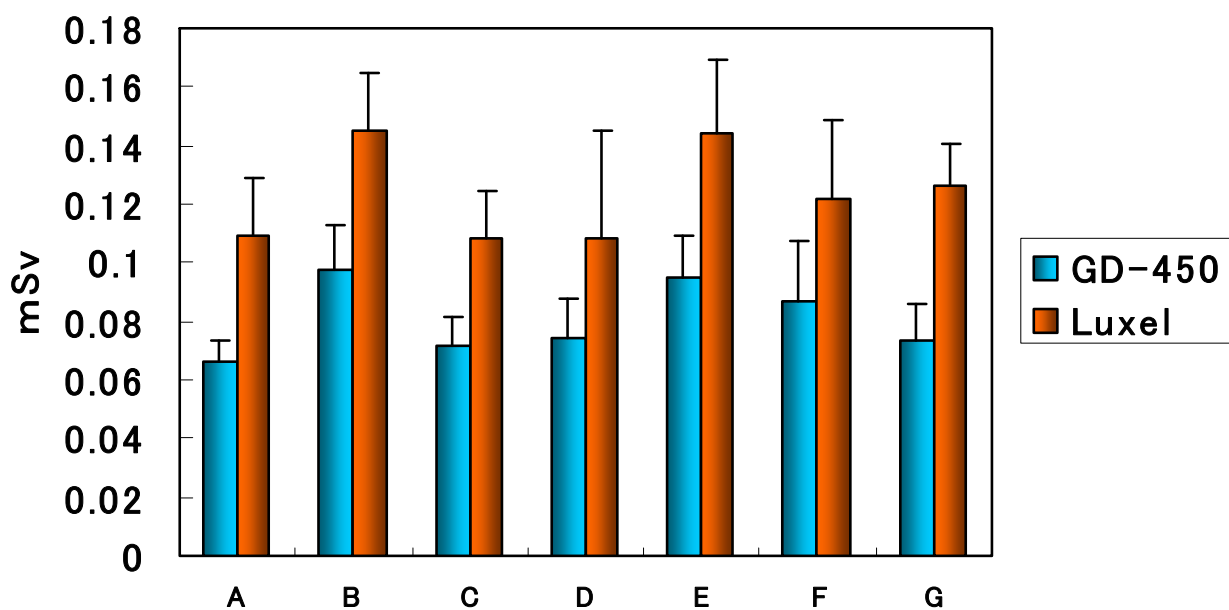

Fig. 17. Dose response at each point in Ishikawa prefecture (A: Tsurugi-machi, B: Tatsunokuchi, C: Inside of house of Mt. Shishiku, D: Outside of Mt. shishiku, E: Inside of Ogoya Mines, F: Outside of Ogoya Mines, G: Public health and Environmental Science) using GD-450 (blue bars) or Luxel badge (orange bars) dosimeters.

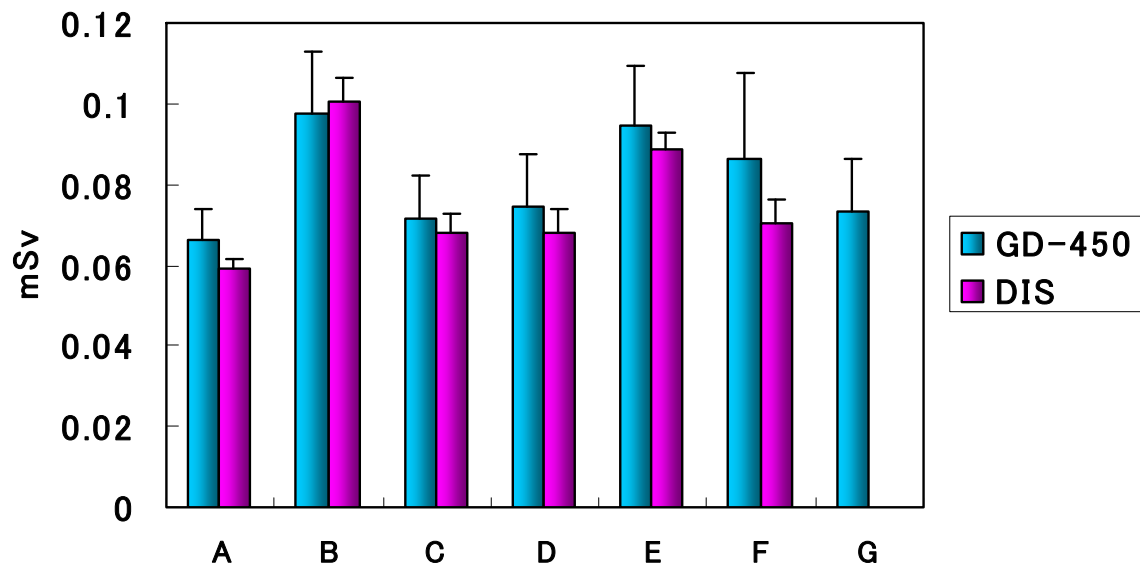

Fig. 18. Dose response at each point in Ishikawa prefecture (A: Tsurugi-machi, B: Tatsunokuchi, C: Inside of house of Mt. Shishiku, D: Outside of Mt. shishiku, E: Inside of Ogoya Mines, F: Outside of Ogoya Mines, G: Public health and Environmental Science) using GD-450 (blue bars) or DIS (purple bars) dosimeters. There is no data at G for DIS.

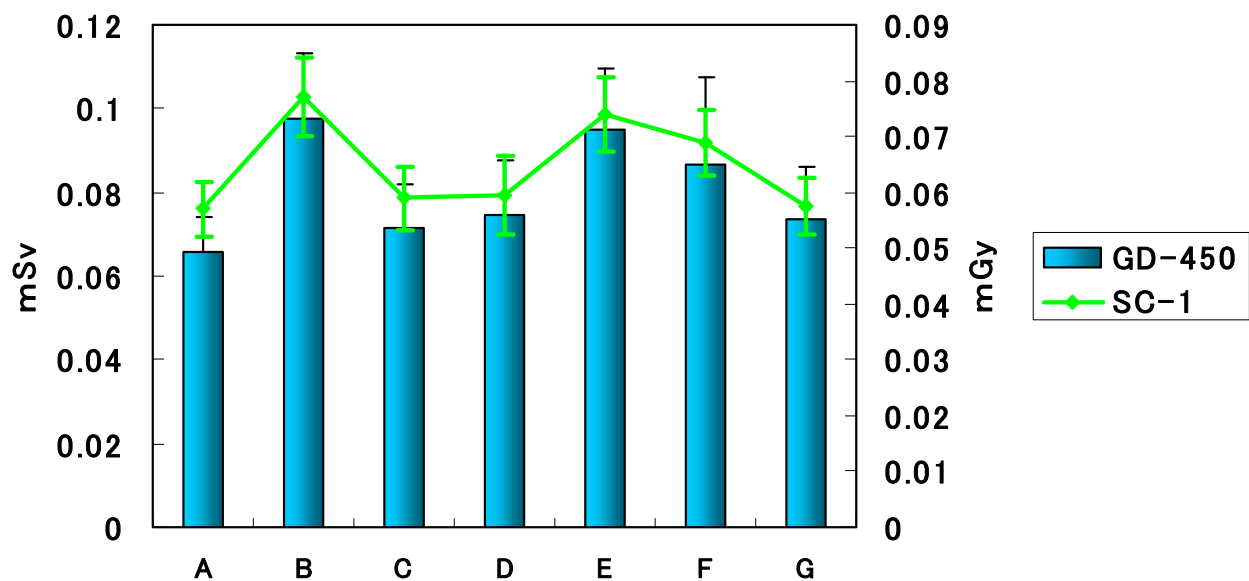

Fig. 19. Dose response at each point in Ishikawa prefecture (A: Tsurugi-machi, B: Tatsunokuchi, C: Inside of house of Mt. Shishiku, D: Outside of Mt. shishiku, E: Inside of Ogoya Mines, F: Outside of Ogoya Mines, G: Public health and Environmental Science) using GD-450 (blue bars) or SC-1 (green line) dosimeters. The unit of the GD-45 and SC-1 are represented by mSv and mGy, respectively.

From the results as described above, Monitoring environmental natural background radiation dose with a personal GD-450 seems to be feasible and consequently, one can say that the GD-450 dosimeter can be suitable for monitoring environmental natural background radiation dose.

## 5. Summary

Environmental natural background radiation dose values at 7 points in Ishikawa prefecture determined using the personal glass dosimeter, type GD-450 were compared with these determined some other personal dosimeters such as DIS dosimeter utilizing a MOSFET with an ionization chamber and OSL dosimeter, Luxel badge, utilizing OSL phenomenon in  $\text{Al}_2\text{O}_3:\text{C}$  phosphor. The actual dose values were different from each other, however, the tendency of each dose at each point were very similar. It can be said that the personal glass dosimeter will be very useful for not only monitoring personal dose but also monitoring natural background radiation dose.

## 6. Acknowledgements

The author wish to thank Dr.Yamamoto, Director of the Research Center of Chiyoda Technol Corp. for his fruitful discussion and Dr.Kobayashi of Nagase Landauer Co. Ltd, Dr. Kakimoto of Ishikawa Prefecture Institute of Public health and Environment Science for their excellent assistance.

The work on the environmental natural background radiation monitoring using solid state passive dosimeters was partially supported by the foundation for Open-Research Center Program from the Ministry of Education, Culture, Sport, Science and Technology of Japan and Chiyoda Technol Corp.

## 7. References

- Kobayashi, I, (2004), The detection of the Environmental radiation for DIS and Luxel badge, *Ionizing Radiation*, Vol.30, pp.33-43.
- Koyama, S., Miyamoto, Y., Fujiwara, A., Kobayashi, H., Ajisawa, K., Komori, H., Takei, Y., Nanto, H., Kurobori, T., Kakimoto, H., Sakakura, M., Shimotsuma, Y., Miura, K., Hirao, K. And Yamamoto, T., (2010), *Environmental Radiation Monitoring Utilizing Solid State Dosimeters*, *Sensors and Materials*, Vol.22, No.7, 377-385.
- Miyamoto, Y., Takei, Y., Nanto, H., Kurobori, T., Konnai, A., Yanagida, T., Yoshikawa, A., Shimotsuma, T., Sakakura, M., Miura, K., Hirao, K., Nagashima, Y. and Yamamoto, T., (2011), *Radiophotoluminescence from Silver-Doped phosphate Glass*, *Radiation Measurements*, in press.
- Murata, Y., Yamamoto, M. and Komura, K., (2002), Determination of low-level  $^{54}\text{Mn}$  in soils by ultra low-background gamma-ray spectrometry after radiochemical separation, *J. Radiational Nucl. Chem*, Vol.254, No.2, pp.249-257.
- Hsu, S.M., Yeh, S.H., Lin, M.S. and Chen, W.L., (2006), Comparison on characteristics of radiophotoluminescent glass dosimeters and thermoluminescent dosimeters, *Radiation Protection Dosimetry*, 119, 327-331.
- Nanto, H., (1998), *Photostimulated Luminescence in Insulators and Semiconductors*, *Radiation Effects & Defects in Solids*, Vol.146, pp.311-321.



- Nanto, H., (1999), Physics of photosimulable phosphor materials, *Ionizing Radiation*, Vol. 25, No.2, pp.9-24. (in Japanese)
- Nanto, H., Takei, Y., Nishimura, A., Nankano, Y., Shouji, T., Yanagida, T., Kasai, S., (2006), Novel X-ray Imaging Sensor Using Cs:Br:Eu Phosphor for Computed Radiography, *Proc. of SPIE*, Vol. 6142, pp.6142w-1-6142w9.
- Nanto, H., (2011), Basic principle of accumulation-type personal dosimeter for ionizing radiation and its application, *Ionizing Radiation*, Vol.37, No.2, pp.3-9.
- Ranogajec-Komor, M., Knezevic, Z., Miljanic, S. And Velic, B., (2008), Characteristics of radiophotoluminescent dosimeters for environmental monitoring, *Radiation measurements*, Vol.43, 392-396.
- Saez-Vergara, J.C., (1999), Practical Aspects on The Implementation of LiF:Mg, Cu, P in Routine Environmental Monitoring Program, *Radiation Protection Dosimetry*, Vol.1-4, pp.237-244.
- Sarai, A., Kurata, N., Kamijo, K., Kubota, N., Takei, Y., Nanto, H., Kobayashi, I., Komori, H., and Komura, K., (2004), Detection of self-dose from an OSL dosimeter and a DIS dosimeter for environmental radiation monitoring, *J. Nuclear Science and Technology*, Suppl. 4, pp.474-477.
- Wernli, C., (1998), Direct ion storage dosimeters for individual monitoring, *Radiation Protection Dosimetry*, Vol.77, pp.253-259.

IntechOpen



## **Environmental Monitoring**

Edited by Dr Ema Ekundayo

ISBN 978-953-307-724-6

Hard cover, 528 pages

**Publisher** InTech

**Published online** 04, November, 2011

**Published in print edition** November, 2011

"Environmental Monitoring" is a book designed by InTech - Open Access Publisher in collaboration with scientists and researchers from all over the world. The book is designed to present recent research advances and developments in the field of environmental monitoring to a global audience of scientists, researchers, environmental educators, administrators, managers, technicians, students, environmental enthusiasts and the general public. The book consists of a series of sections and chapters addressing topics like the monitoring of heavy metal contaminants in varied environments, biological monitoring/ecotoxicological studies; and the use of wireless sensor networks/Geosensor webs in environmental monitoring.

### **How to reference**

In order to correctly reference this scholarly work, feel free to copy and paste the following:

Hidehito Nanto, Yoshinori Takei and Yuka Miyamoto (2011). Environmental Background Radiation Monitoring Utilizing Passive Solid Sate Dosimeters, Environmental Monitoring, Dr Ema Ekundayo (Ed.), ISBN: 978-953-307-724-6, InTech, Available from: <http://www.intechopen.com/books/environmental-monitoring/environmental-background-radiation-monitoring-utilizing-passive-solid-sate-dosimeters>

**INTECH**  
open science | open minds

### **InTech Europe**

University Campus STeP Ri  
Slavka Krautzeka 83/A  
51000 Rijeka, Croatia  
Phone: +385 (51) 770 447  
Fax: +385 (51) 686 166  
[www.intechopen.com](http://www.intechopen.com)

### **InTech China**

Unit 405, Office Block, Hotel Equatorial Shanghai  
No.65, Yan An Road (West), Shanghai, 200040, China  
中国上海市延安西路65号上海国际贵都大饭店办公楼405单元  
Phone: +86-21-62489820  
Fax: +86-21-62489821

© 2011 The Author(s). Licensee IntechOpen. This is an open access article distributed under the terms of the [Creative Commons Attribution 3.0 License](#), which permits unrestricted use, distribution, and reproduction in any medium, provided the original work is properly cited.

IntechOpen

IntechOpen