

We are IntechOpen, the world's leading publisher of Open Access books Built by scientists, for scientists

4,800

Open access books available

122,000

International authors and editors

135M

Downloads

Our authors are among the

154

Countries delivered to

TOP 1%

most cited scientists

12.2%

Contributors from top 500 universities



WEB OF SCIENCE™

Selection of our books indexed in the Book Citation Index
in Web of Science™ Core Collection (BKCI)

Interested in publishing with us?
Contact book.department@intechopen.com

Numbers displayed above are based on latest data collected.

For more information visit www.intechopen.com



Role of RPA Proteins in Radiation Repair and Recovery

Patrick E. Gygli, J. Scott Lockhart and Linda C. DeVeaux
*Idaho State University,
USA*

1. Introduction

Repair of radiation-induced DNA damage requires a complex series of protein interactions. Single-stranded DNA (ssDNA) binding proteins (RPA/SSB) have long been known to play a passive, protective role in DNA replication and repair, by coating ssDNA. Recent evidence, however, suggests a much more active function for these ubiquitous proteins. In this review, we provide a summary of the background of ssDNA binding proteins, and incorporate recent experimental observations into current models of dynamic interactions between these proteins and cellular DNA repair enzymes. These results point to a highly choreographed, interactive mechanism, with RPA/SSB at the center of the coordination.

2. Structure

There are two primary classes of ssDNA binding proteins, which share secondary and tertiary structural features, but are distinct in their quaternary structures. The eukaryotic Replication Protein A class (RPAs) consists of heterotrimeric proteins while the bacterial class (SSBs) consists of a range of homo-multimers. Members of the archaeal domain may possess either the RPA or SSB types, or combinations unique to this domain, illustrated in Figure 1 (Kerr, et al., 2003; Lin, et al., 2008; Richard, et al., 2009; Shereda, et al., 2008; Wold, 1997).

SSBs/RPAs are primarily identified by the presence of a structurally conserved oligonucleotide/oligosaccharide binding motif (OB-fold) (Kerr, et al., 2003; Richard, et al., 2009; Shereda, et al., 2008; Theobald, et al., 2003; Wold, 1997). The canonical OB-fold consists of five structurally conserved β -strands, forming two β -sheets, and their inter-spaced variable loops, which form a tertiary flattened β -barrel. The non-specific binding of ssDNA occurs on the surface of the β -barrel in a cleft between the variable loops. The binding of nucleotides is mediated through stacking interactions with aromatic residues and packing interactions with hydrophobic residues. Binding to the phosphodiester backbone also occurs through electrostatic interactions. The OB-folds have a binding polarity that specifies the orientation on the bound ssDNA (Shereda, et al., 2008; Theobald, et al., 2003).

The majority of bacterial and mitochondrial SSBs function as homotetramers, with a single OB-fold per monomer and thus four OB-folds per complex. For members of the *Deinococcus/Thermus* branch, the SSB functions as a homodimer and maintains the theme of four OB-folds per complex by having two non-identical OB-folds per monomer (Bernstein, et al., 2004; Eggington, et al., 2004; Filipkowski, et al., 2006; Filipkowski & Kur, 2007;

Shereda, et al., 2008). These SSB complexes occlude up to 65 and 35 nucleotides of ssDNA, respectively (Filipkowski & Kur, 2007; Meyer & Laine, 1990; Shereda, et al., 2008). Other, less common SSB configurations have also been identified, including an alternative homopentameric Deinococcal SSB (Norais, et al., 2009; Sugiman-Marangos & Junop, 2010). In general, the N-terminal region of the SSB contains the oligomerization domain while the C-terminal region is implicated in heterologous protein interactions (Shereda, et al., 2008).

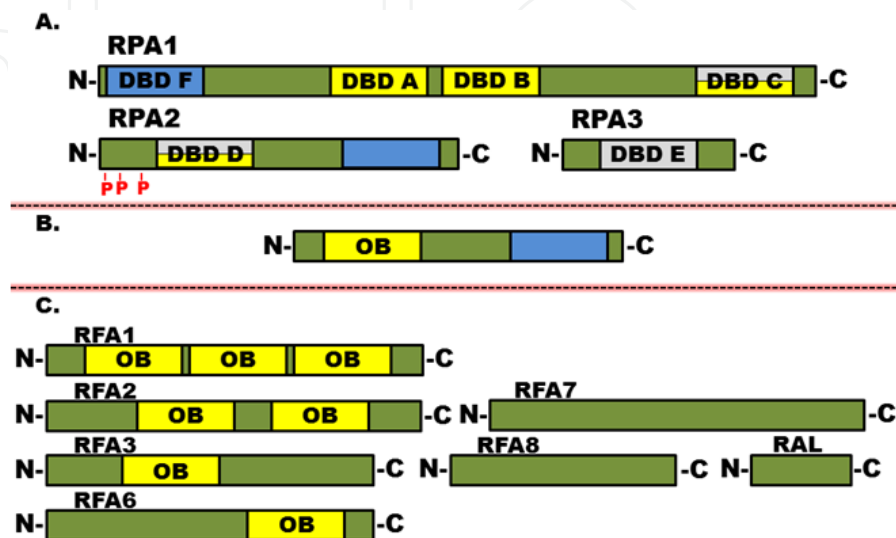

Fig. 1. RPA and SSB structures from eukaryotes, bacteria, and archaea. (A) The canonical eukaryotic RPA comprises three protein subunits, each containing OB-folds designated DBD A-F. Yellow OB-folds are DNA interacting domains, blue domains are involved in heterologous protein interactions, and gray domains are involved in maintenance of RPA structure. The N-terminus of RPA2 is the primary phosphorylation domain, denoted by red Ps. (B) The canonical bacterial SSB functions as a homotetramer and contains a single OB-fold (yellow) and a C-terminal heterologous protein interacting domain (blue) per monomer. (C) Archaeal RPAs are diverse and display characteristics of both eukaryotic RPA and bacterial SSB. Examples from *H. salinarum* are shown. RFA6 resembles bacterial SSB, whereas RFA1 is uniquely archaeal. The genes encoding RFA2 and RFA7, which are found in an operon, likely function as a multimeric protein, as do RFA3, RFA8, and RAL.

The eukaryotic RPA is a heterotrimer composed of a large RPA1 (~72 kDa), medium RPA2 (~32 kDa), and small RPA3 (~14 kDa) subunit. RPA1 and RPA2 tend to be conserved subunits with a variable RPA3, though considerable variation can occur throughout domains (Lin, et al., 2008; Wold, 1997). RPA1 contains four OB-folds referred to as DNA binding domains (DBD). DBD A and B are centrally located, DBD C is in the C-terminal region, and DBD F is in the N-terminal region. RPA2 contains a single centrally located OB-fold, DBD D, and RPA3 a single centrally located OB-fold, DBD E (Binz, et al., 2004; Oakley, et al., 2009; Pretto, et al., 2010). ssDNA binding occurs primarily through interaction with DBD A-D, which together are capable of occluding approximately 30 nucleotides (Blackwell & Borowiec, 1994; Iftode, et al., 1999; C. Kim, et al., 1992; Theobald, et al., 2003). A binding polarity of the complex is achieved through decreased ssDNA affinity from DBD A to D (Oakley, et al., 2009; Pretto, et al., 2010). The N-terminal domain of RPA1 is implicated in heterologous protein interactions and regulation, particularly through DBD F, while the C-terminal domain is involved in heterotrimer structure interactions (Broderick, et al., 2010);

Fanning, et al., 2006; Oakley, et al., 2009; Wold, 1997). The N-terminus of RPA2 contains a regulatory phosphorylation domain that affects interactions of RPA with other proteins, as well as its DNA binding kinetics (Machwe, et al., 2011; Nuss, et al., 2005; Oakley, et al., 2009; Patrick, et al., 2005; Vassin, et al., 2009). The C-terminal region of RPA2 is also involved in heterologous protein interactions and regulation. RPA3 consists almost entirely of DBD E and is thought to be involved primarily in heterotrimer formation, but potential roles in heterologous protein interactions have been identified (Cavero, et al., 2010; Wold, 1997).

3. Multiplicity of homologs

The highly conserved nature of the OB-fold has allowed identification of potential RPA/SSB homologs in the ever-expanding genome sequence database. To our knowledge, there have been no reports of genomes lacking an RPA/SSB homolog, with the possible exception of the crenarchaea *Pyrobaculum aerophilum* and *Aeropyrum pernix* (Luo, et al., 2007).

There are numerous excellent and extensive reviews covering the history, genetics and biochemical characterization of *E. coli* SSB and its encoding gene (Lohman & Ferrari, 1994; Meyer & Laine, 1990; Shereda, et al., 2008). The single gene, *ssb*, is located adjacent to, but divergently transcribed from, the *uvrA* gene (Brandsma, et al., 1985). In *Bacillus subtilis*, there are two SSB genes, *ssb* and *ywpH* (Lindner, et al., 2004). Although the amino acid sequences of the two proteins are similar, YwpH lacks the C-terminal region found in both the *E. coli* and *B. subtilis* SSBs. *B. subtilis* *ssb* is essential, but unlike in *E. coli*, is found between ribosomal protein genes. Of 87 bacterial genomes analyzed, all contained at least one SSB gene (Lindner, et al., 2004). Based on gene organization, four groupings were proposed: Group I organisms display *B. subtilis*-type gene organization and more than one SSB. Group II organisms contain only one gene for SSB. *E. coli* represents the type organism for Group III bacteria, where the single *ssb* gene is divergently transcribed from the adjacent *uvrA* gene. Group IV consists of organisms whose SSB organization does not resemble either *B. subtilis* or *E. coli*. *Thermotoga maritima* and *T. neopolitana* likely fall into Group IV, whereas *Thermoanaerobacter tengcongensis* is in Group I (Olszewski, et al., 2010; Olszewski, et al., 2008).

Recently, a novel homopentameric SSB, DdrB, was identified in *Deinococcus radiodurans*, which may challenge previous notions regarding canonical SSB structure (Norais, et al., 2009; Sugiman-Marangos & Junop, 2010). Restricted to the Deinococcal lineage, it may represent an adaptation related to the unusually high DNA repair capacity of this organism. However, it should be kept in mind that other SSB proteins that deviate from the traditional consensus may yet be identified (Norais, et al., 2009; G. Xu, et al., 2010).

Three separate genes encode the canonical eukaryotic RPA, which is the subject of several recent review articles (Binz, et al., 2004; Broderick, et al., 2010; Richard, et al., 2009; Wold, 1997). However, in higher plants each subunit of RPA may be represented by multiple genes whose proteins function in distinct processes (Sakaguchi, et al., 2009).

Both *Saccharomyces cerevisiae* and *Schizosaccharomyces pombe* contain a single gene for each of the three RPA subunits. All three are essential in *S. cerevisiae*, but RPA3 appears to be non-essential in *S. pombe* (Brill & Stillman, 1991; Cavero, et al., 2010; Dickson, et al., 2009; Maniar, et al., 1997). Given that RPA3 is the most variable, and the essential role that the intact protein plays in replication, an additional RPA3 gene may yet be identified that carries out this role in *S. pombe*. In addition to heterotrimeric RPA, a protein complex, Stn1/Ten1, resembling an RPA2/RPA3 dimer has been found to be necessary for telomere maintenance

and protection in *S. cerevisiae*, *S. pombe* and *Candida albicans* (Sun, et al., 2009). Together with Cdc13, the Stn1/Ten1 complex may represent a highly conserved telomere binding RPA.

Mammals are thought to have only one nuclear RPA protein, which functions in both replication and repair (Fanning, et al., 2006; Iftode, et al., 1999; Wold, 1997). However, an alternative RPA2 homolog (RPA4) found only in mammals has been identified (Keshav, et al., 1995). RPA4 binds with the single RPA1 and RPA3 subunits to form an alternative RPA that does not interact with DNA polymerase α , and consequently, does not support replication (Haring, et al., 2010; Mason, et al., 2009; Mason, et al., 2010). Rather, its role is restricted to repair, particularly in quiescent cells. A mitochondrial SSB has also been identified in many eukaryotes, which has sequence and structural similarities to *E. coli* SSB (Curth, et al., 1994). In addition, two human proteins, hSSB1 and hSSB2, which structurally resemble bacterial SSB, have been reported. hSSB1 has been characterized, and appears not to be involved in replication, but is required for genome stability and DNA repair processes (Richard, Cubeddu, et al., 2011; Richard, Savage, et al., 2011).

Although much less is known about RPA genes in plants, the recent sequencing of higher plant genomes has revealed a large diversity of homologs (Sakaguchi, et al., 2009). Rice contains three genes each for RPA1 and RPA2, but only a single gene for RPA3 (Ishibashi, et al., 2006; Shultz, et al., 2007). Each RPA1 associates with a particular RPA2, and RPA3 is common among the different complexes. One complex is unique to chloroplasts, whereas the other two are nuclear. Like rice, *Arabidopsis* contains multiple homologs for the RPA1 and RPA2 subunits, but also has two RPA3 genes (Shultz, et al., 2007). In both plants, one of the large subunits has been shown to be non-essential for vegetative growth, but is required for meiosis, demonstrating specialization of function among the multiple species of protein (Chang, et al., 2009; Osman, et al., 2009). This homolog is involved in response to DNA damage as well as maintenance of telomeres (Takashi, et al., 2009). The degree of similarity among the multiple homologs suggests that they arose through duplication of ancestral genes after the establishment of the plant lineage.

By far the most diversity in RPA/SSB homologs is found in the archaea. Although many hypothetical RPA proteins have been identified in the numerous genomes analyzed, there is no quaternary structure that is common to all. In the crenarchaea, the RPA from *Sulfolobus solfataricus* is encoded by a single gene and exists as a monomer or a homotetramer (Haseltine & Kowalczykowski, 2002; Kerr, et al., 2001; Kerr, et al., 2003; Wadsworth & White, 2001). The different quaternary structures confer distinct binding capabilities (Rolfmeier & Haseltine, 2010). Despite the similarity to bacterial SSB, and the ability of the gene to complement the lethality of an *E. coli* *ssb* mutation, the DNA-binding domain of this protein more closely resembles those of eukaryotic RPA1 (Haseltine & Kowalczykowski, 2002; Kerr, et al., 2003). Although the genomes of two related crenarchaea, *P. aerophilum* and *A. pernix*, have been reported to contain no obvious RPA or SSB homolog (Luo, et al., 2007), a previous study found a *Sulfolobus*-like SSB in *A. pernix* (Haseltine & Kowalczykowski, 2002). Given the recent identification of a novel SSB in *D. radiodurans*, and the fundamental role that ssDNA binding proteins play in replication and repair, it is likely that a protein carrying out these essential functions will be found in all organisms.

RPAs in euryarchaea present a multitude of OB-fold conformations that presumably provide unique functions (Lin, et al., 2005; Robbins, et al., 2005). Genomes of several euryarchaea, including *Thermoplasma acidophilum*, *Archaeoglobus fulgidus*, *Ferroplasma acidarmanus*, and *Halobacterium salinarum*, contain genes with similar organization to the crenarchaeal SSB/RPA gene, with one OB-fold; however, in each case, there is also at least

one additional homolog that shows different domain structure, as seen in Figure 1 (Komori & Ishino, 2001; Pugh, et al., 2008; Robbins, et al., 2005). Other euryarchaea, such as *Methanococcus jannaschii*, *Methanobacter thermoautotrophicus*, and the Methanosarcinae, have proteins with four OB-folds, which may act as monomers, or in a complex with an adjacently encoded RPA2 homolog (Chedin, et al., 1998; Kelly, et al., 1998; Komori & Ishino, 2001; Lin, et al., 2008; Robbins, et al., 2004). In addition, *M. jannaschii* contains a two-OB-fold homolog which appears to function as a homotrimer (Robbins, et al., 2005). The *Pyrococcus furiosus* RPA more closely resembles eukaryotic RPA, with three distinct subunits that function as a heterotrimer and whose genes compose an operon (Komori & Ishino, 2001). In *H. salinarum*, Rfa3, Rfa8, and Ral, and Rfa2 and Rfa7 resemble the *P. furiosus* RPA with respect to operon structure and sequence homology to eukaryotic RPA (Figure 1). Rfa6 resembles the crenarchaeal SSB/RPA in gene and OB-fold structure, while Rfa1 appears more uniquely archaeal, with three OB-folds (DeVeaux, et al., 2007; Robbins, et al., 2005). The roles of the RPA-like homologs in *H. salinarum* will be discussed further below.

4. Characterized mutations of RPA and SSB

E. coli SSB mutants were first isolated in a screen for DNA replication mutants (Meyer & Laine, 1990). Although the two best-characterized of these temperature-sensitive (ts) mutations, *ssb-1* and *ssb-113*, fail to grow at 42° C due to inability of the labile SSB to participate in DNA replication, *ssb-1* mutants have essentially normal phenotypes at the permissive temperature. The mutation (H55Y) resides in the OB-fold and affects the ability of the protein to form homotetramers (Shereda, et al., 2008). In contrast, even at the permissive growth temperature, *ssb-113* mutants are severely compromised in their ability to survive numerous DNA damaging agents, and display recombination deficiencies (Chase, et al., 1984). The extremely pleiotropic phenotype conferred by the amino acid change (P176S of 177) in *ssb-113* suggests that the protein interaction capabilities of the C-terminal region are necessary for more than just replication. A protein lacking only 10 amino acids from the C-terminus is non-functional (Curth, et al., 1996). Indeed, mutation of the terminal phenylalanine is lethal, and disrupts protein-protein interactions (Genschel, et al., 2000). These phenotypes provided support not only for the commonality of protein function in recombination, repair, and replication, but also early evidence that these roles were separable within an individual protein. In contrast, a *B. subtilis* mutant in which SSB lacks the C-terminal 35 amino acids, involved in interaction with the helicase PriA, is viable, demonstrating that this conserved region is not essential in all bacteria (Lecoite, et al., 2007). In the budding yeast *S. cerevisiae*, all three subunits of RPA are essential (Brill & Stillman, 1991; Maniar, et al., 1997). Like *E. coli ssb-113* mutants, ts-mutants of RPA1 are profoundly UV- and ionizing radiation (IR)-sensitive at the permissive temperature (Parker, et al., 1997). Several ts-mutants display a mutator phenotype, which is likely related to defects in replication rather than repair (Chen, et al., 1998). Small insertions in either the RPA1 DNA-binding domain or the N-terminal protein-interaction domain result in a marked decrease in survival after UV exposure; however, only the latter is defective in the cell-cycle response to such damage. In addition, only the DNA-binding mutant is defective in repair of UV-induced lesions (Longhese, et al., 1996; Teng, et al., 1998). The N-terminal domain is required for interactions with the clamp loader. This binding is abolished in the *rfa1-t11* mutation, which contains a single change (K45E) (H. S. Kim & Brill, 2001; Majka, et al., 2006; Umezumi, et al., 1998). This same allele is deficient in many pathways requiring interactions

with DNA processing proteins, including repair of DNA breaks incurred during meiotic recombination, and interaction with Rad51 and its mediator Rad52 (Soustelle, et al., 2002; Sugiyama & Kantake, 2009). Deletion of either the N-terminal 20 amino acids or any deletion at the C-terminus is lethal (Philipova, et al., 1996). In the fission yeast *S. pombe*, as in *S. cerevisiae*, mutations in the large subunit gene confer sensitivity to DNA damaging agents such as UV; in addition, these mutations confer a deficiency in telomere maintenance that is seen in *S. cerevisiae* only in combination with a Ku mutation (Ono, et al., 2003).

In *S. cerevisiae*, mutations in RPA2 also confer sensitivity to various DNA-damaging agents and display defects in replication fidelity (Maniar, et al., 1997; Santocanale, et al., 1995). Ts-mutants arrest in S phase at the nonpermissive temperature. Although the protein is essential, the DNA-binding domain is not; only the central protein-interaction domain is required (Dickson, et al., 2009; Philipova, et al., 1996). Temperature-sensitive mutations in RPA3 confer a replication defect in *S. cerevisiae*. Whereas replication ceases immediately in ts-mutants of RPA2, RPA3 mutations allow one round of replication before cessation (Maniar, et al., 1997). As in RPA1, deletions of the RPA3 N-terminus are viable, but C-terminal deletions are not tolerated (Philipova, et al., 1996). Interestingly, RPA3 is not essential in *S. pombe*, and is dispensible in meiosis (Cavero, et al., 2010). However, cells containing a gene deletion show marked sensitivity to DNA damaging agents, particularly those interfering with replication, but not to IR. This suggests that RPA3 in *S. pombe* is involved in repair of replication damage, but not homologous recombination. It is possible that an additional RPA3 homolog will be discovered in *S. pombe* that carries out the essential role in replication performed by a single RPA3 in other organisms.

In human cells, depletion of RPA results not only in increased spontaneous DNA damage and decreased cell viability, but also in asynchrony, arrest at the G1/S boundary, a slowing of progression through S phase, and arrest at the G2/M checkpoint (Dodson, et al., 2004; Haring, et al., 2008). The G2/M arrest was found to be the result of constitutive activation of ATM (ataxia telangiectasia mutated) kinase resulting from lack of RPA. Cells harboring mutations in DBD A, B or C are able to replicate DNA, and traverse S phase, but arrest at the G2/M checkpoint. In contrast to yeast, the N-terminal 168 amino acids of RPA1 are not essential for replication or cell-cycle progression. RPA1 mutants defective in ssDNA binding are still able to support replication; however, some mutants with very modest defects in DNA binding are severely compromised in cell-cycle progression (Haring, et al., 2008). One mutation, L221P, in which a highly conserved leucine in DBD A is changed to proline, has been characterized in yeast (Chen & Kolodner, 1999; Chen, et al., 1998), in mice (Wang, et al., 2005), and in humans (Hass, et al., 2010), and has been shown to promote chromosomal instability. This mutation is lethal in mice; heterozygosity leads to shortened life spans and increased cancer incidence. The conservation of this residue and the drastic phenotype associated with its replacement indicates a critical role of this DNA binding domain in the fundamental role of RPA in replication. A mutation changing another conserved residue in the same domain, D227Y, causes telomere shortening in human cancer cells (Kobayashi, et al., 2010), as does the analogous change in yeast (Ono, et al., 2003). Much less is known about mutations of the two smaller subunits in mammalian systems. However, as in yeast, human RPA2 is required for replication, and the only essential region is the central protein-interacting domain (Fanning, et al., 2006; Haring, et al., 2010).

Higher plants contain multiple homologs of at least the large and medium subunits. In rice, one homolog of RPA1 is not essential during vegetative growth, but mutants are sterile, indicating a meiotic defect (Chang, et al., 2009). Also, mutants are sensitive to DNA-

damaging agents, indicating a role in repair but not replication. Likewise, in *Arabidopsis thaliana*, deletion of one RPA1 homolog results in meiotic defects; although DNA breaks appear to be repaired normally, there is a deficiency in meiotic crossover (Osman, et al., 2009). During vegetative growth, plants containing this mutation are sensitive to DNA-damaging agents (Takashi, et al., 2009). The presence of multiple homologs, some of which are not essential and appear not to be involved with replication, suggests that RPAs in plants have duplicated and diverged, resulting in specialization and separation of function.

5. Interactive roles of RPA and SSB in DNA metabolism

While RPAs and SSBs are indispensable for normal replication, they are also central to nearly all DNA repair pathways. The overarching theme for RPA/SSB in these repair pathways is their function as directors of key enzymatic proteins without themselves being enzymatic. The following sections will pertain to the canonical RPA and SSB unless otherwise noted.

5.1 Interactive role of RPA and SSB in the unstressed cell cycle

RPA plays a critical role in replication of DNA and was first identified as a factor for replication of the Simian Virus 40 (SV40). Several reviews provide great detail about the role of RPA in replication; however, most current work examines its function in DNA repair (Fanning, et al., 2006; Iftode, et al., 1999; Wold, 1997). Nevertheless, it is important to understand the role of RPA in normal DNA replication as the switch between its replication role and its repair role is of great interest.

During replication, RPA functions to protect ssDNA and direct the assembly of the replication machinery. In SV40 replication, RPA interacts with T-antigen to facilitate unwinding of the replication origin, through ssDNA stabilization as well as DNA-duplex melting (Georgaki & Hubscher, 1993; Georgaki, et al., 1992; Iftode, et al., 1999; Wold, 1997). Interestingly, nearly all RPAs and SSBs are able to replace human RPA in this role, indicating that stability of the ssDNA intermediate is critical for progression of replication (Wold, 1997). In addition, RPA and SSB serve to direct the formation of the replication complex through direct protein-protein interactions (Binz, et al., 2006; Naue, et al., 2011; Shereda, et al., 2008; Witte, et al., 2003; Wold, 1997; Yuzhakov, Kelman, Hurwitz, et al., 1999).

RPA spatially and temporally directs the addition of key proteins of the replication complex at the site of replication. Temporal control is obtained through competitive binding of the replication components to RPA. Initially, the primase complex is directed to the ssDNA template. Following primer synthesis, Replication Factor C (RFC) binds RPA and loads the replicative clamp PCNA. DNA polymerase δ then binds RPA and is loaded at the DNA-primer junction, allowing DNA replication to begin (Yuzhakov, et al., 1999). These protein-protein interactions are RPA-specific; SSB cannot substitute, underscoring the important dual role of RPA in both ssDNA binding and protein interactions (Wold, 1997).

Though RPA and SSB cannot always substitute for each other, they play similar roles in the systems in which they reside. Like RPA, SSB serves not only to stabilize ssDNA but also to direct assembly of the replication complex proteins. Through interactions with the C-terminus of SSB, the primase is loaded and retained at the priming site. This interaction may be facilitated through further interactions of SSB with DnaB. This binding is disrupted by the χ subunit of the replicative DNA polymerase III through a multi-step handoff mechanism (Sharma, et al., 2009; Shereda, et al., 2008; Witte, et al., 2003; Yuzhakov, Kelman, & O'Donnell, 1999). Loss of these protein-protein interactions results in cellular demise.

Integral to the role of RPA in DNA replication is its cell-cycle dependent phosphorylation/dephosphorylation (Figure 2). Specifically, RPA2 is phosphorylated at two consensus sites for Cdc2/Cdk2, resulting in three forms of RPA: unphosphorylated, and two distinct phosphorylated forms (Iftode, et al., 1999; J. S. Liu, et al., 2006; Oakley, et al., 2003; Patrick, et al., 2005; Wold, 1997; Zernik-Kobak, et al., 1997). The majority of RPA is unphosphorylated during G1 phase, and is phosphorylated at either S23 or S29 of RPA2 at the G1/S phase boundary, which is maintained through S phase and into G2 (Anantha, et al., 2007; Oakley, et al., 2003; Stephan, et al., 2009). Near the G2/M phase boundary, a mitotic phosphorylation form becomes abundant (Oakley, et al., 2003; Zernik-Kobak, et al., 1997). This is presumably due to further phosphorylation of RPA2 at the remaining Cdc2/Cdk2 consensus site, which may regulate the ability of RPA to interact with and bind other proteins, thereby modulating its functional role through the cell-cycle (Oakley, et al., 2003; Stephan, et al., 2009). However, the effects of S phase phosphorylation of RPA have not yet been determined, as its ability to support replication and repair are unchanged (Henricksen, et al., 1996; Oakley, et al., 2003; Pan, et al., 1995). In contrast, M phase phosphorylation of RPA abrogates binding to DNA polymerase α , as well as to the checkpoint proteins ATM and DNA-PK (DNA-dependent protein kinase). In addition, its ability to bind duplex DNA is significantly reduced. These modifications may serve to switch RPA away from its replicative role after S phase (Oakley, et al., 2003; Stephan, et al., 2009). It has also been demonstrated that SSB is phosphorylated on tyrosine residues, but the consequences of this phosphorylation remain to be elucidated (Mijakovic, et al., 2006). As such, phosphorylation will be discussed only in relation to RPA for the remainder of this review. Nevertheless, it is reasonable to hypothesize that phosphorylation of SSB plays a similar regulatory role.

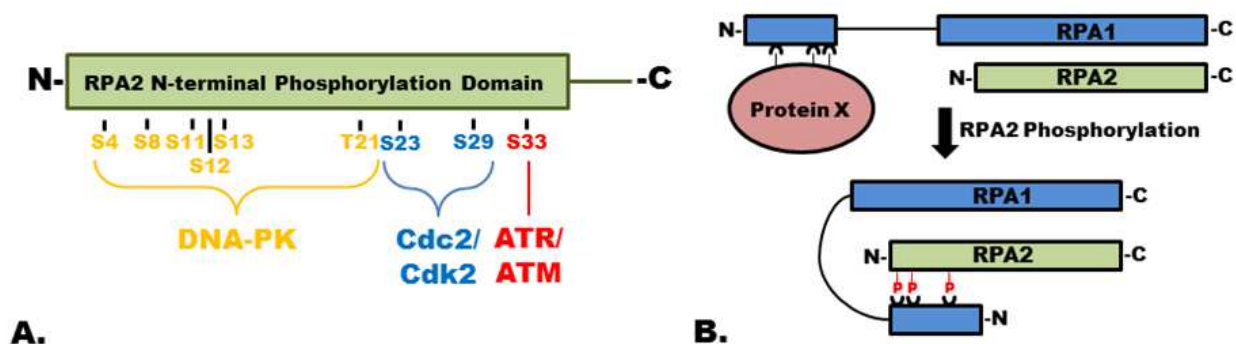

Fig. 2. (A) Phosphorylation sites on the N-terminus of RPA2. DNA-PK, Cdc2/Cdk2 and ATR/ATM phosphorylate different sites, which depends on the type of damage and point in the cell-cycle. (B) Proposed mechanism for phosphoregulation of RPA1 N-terminal heterologous protein interactions. Upon phosphorylation of RPA2, the basic N-terminus of RPA1 binds phosphorylated RPA2 and abrogates heterologous protein binding. Protein X represents any of a number of RPA1-interacting proteins.

5.2 Interactive role of RPA and SSB in NER, BER and MMR

Cellular DNA is under a constant barrage of damaging agents, which may cause crosslinking, base modification or base loss. In general, these types of damage may be repaired by excising the offending lesion and re-synthesizing DNA. RPA and SSB play critical roles in the coordination of these processes. Base excision repair (BER) processes remove damaged bases, forming apurinic/apyrimidinic sites, which are removed and

replaced with undamaged DNA (Krokan, et al., 2000). RPA physically interacts with and regulates multiple BER glycosylases, including NEIL1 and Ung2, to facilitate correct repair of lesions, in part by inhibiting excisions on ssDNA and promoting incisions on duplex DNA (Mer, et al., 2000; Theriot, et al., 2010). Similarly, SSB interacts with the glycosylase UDG, stimulating or inhibiting its excision activity, depending on the DNA structure at the lesion (Kumar & Varshney, 1997). Nucleotide excision repair (NER) processes remove helix-distorting lesions by excising a patch of DNA, followed by re-synthesis. In this case, RPA physically interacts with the NER mediator XPA to direct incision to the damaged strand, and to help prevent excessive incision events, which could lead to further degradation of the genome (Krasikova, et al., 2010; Overmeer, et al., 2011; Saijo, et al., 2011). In mismatch repair (MMR), RPA and SSB interact with the exonuclease EXO1 to stimulate excision processes, as well as ensure correct excision termination (Genschel & Modrich, 2009; Lu & Keck, 2008).

5.3 Interactive role of RPA and SSB in the recovery of stalled replication forks

An advancing replication fork must traverse a myriad of DNA lesions through a normal replicative cycle, and the abundance of these lesions increases dramatically under DNA-damaging conditions. Depletion of the nucleotide pool or a single-strand lesion blocks progression of the polymerase complex, while the replicative helicase uncouples from the replisome and continues to unwind template DNA. Such uncoupling results in long segments of ssDNA to which RPA or SSB may bind and actively participate in restart of the stalled fork (Atkinson & McGlynn, 2009; Byun, et al., 2005; McInerney & O'Donnell, 2007; Pages & Fuchs, 2003). Additionally, lesions such as inter-strand crosslinks or covalently linked proteins block advancement of the entire replisome. Such stalls may be repaired and restarted through a fork regression pathway. Several competing fork regression models exist, but all of them require protein elements that closely function and interact with RPA and SSB (Atkinson & McGlynn, 2009; Dronkert & Kanaar, 2001; Machwe, et al., 2011; Shereda, et al., 2007; Shereda, et al., 2008; Sowd, et al., 2009; Sugiyama & Kantake, 2009; Suhasini, et al., 2009; Woodman, et al., 2010; Yuan, et al., 2009; Yusufzai, et al., 2009).

When the replicative helicase is uncoupled from the replisome, large tracts of ssDNA are formed. In eukaryotes this lengthy ssDNA is rapidly coated with RPA, which serves as a signal of replication stress to activate the S phase checkpoint kinase ATR (ATM and Rad3-related), a member of the phosphatidylinositol 3-kinase-like kinase (PIKK) family (Byun, et al., 2005; J. S. Liu, et al., 2006; Zou & Elledge, 2003). In bacteria, the ssDNA is similarly coated with SSB, but a strict cell-cycle control response is absent. ATR is found in a complex with its activator ATRIP (ATR interacting protein) and recruitment of ATR/ATRIP to sites of replication stress is mediated by direct interaction between the N-terminus of RPA1 (DBD F) and ATRIP. This interaction is sufficient for localization of ATR/ATRIP to the stalled replication fork, but activation of ATR requires further protein interactions, also mediated by RPA (X. Xu, et al., 2008; Zou & Elledge, 2003). The Rad17 complex, which comprises Rad17 and RFC subunits 2-5, loads the Rad9-Rad1-Hus1 (9-1-1) DNA damage checkpoint clamp at damage sites. To facilitate loading of the 9-1-1 complex, the Rad17 complex is recruited to damage sites in an RPA-dependent manner (Majka, et al., 2006; Zou, et al., 2003). Rad9 of the 9-1-1 complex binds topoisomerase 2 binding protein 1 (TopBP1), another factor for ATR activation. Simultaneously, Rad9 binds the N-terminus of RPA1 which correctly orients TopBP1 for activation of ATR. Rad9 and ATRIP compete for binding of the N-terminus of RPA1, but each must be bound for efficient activation of ATR. This suggests a model in which

two adjacent RPAs are required to be bound to ssDNA at a damage site (X. Xu, et al., 2008). This model is further supported by studies describing a ssDNA length-dependent activation of ATR via RPA (J. S. Liu, et al., 2006; Zou & Elledge, 2003).

Activated ATR initiates the intra-S phase checkpoint signal cascade resulting in cell-cycle arrest, stabilization of replication forks, and initiation of damage repair through phosphorylation of effector molecules, including the checkpoint kinase Chk1 (Cimprich & Cortez, 2008; Kastan & Bartek, 2004; Yang, et al., 2003). Activation also leads ATR to phosphorylate S33, a PIKK consensus site, of the RPA2 subunit of ssDNA-bound RPA, which stimulates the Cdc2/Cdk2 kinases to phosphorylate their consensus sites on RPA2 if not already phosphorylated. This, in turn, stimulates phosphorylation of T21 by DNA-PK, which leads to further phosphorylation of RPA2 at residues S4, S8, S11, S12, and S13 by DNA-PK (Anantha, et al., 2007; Vassin, et al., 2009; Zernik-Kobak, et al., 1997). Such hyperphosphorylation of RPA is the major switch from its role in normal uninterrupted replication to an activator and director of DNA damage repair.

Hyperphosphorylation inhibits replicative functions of RPA while stimulating repair and fork stabilization, likely by modifying its protein interaction and duplex DNA binding and destabilizing capabilities. In a rather elegant regulatory mechanism, the phosphorylated RPA2 competitively binds the basic N-terminal region of RPA1, displacing proteins from one of the primary binding surfaces and modulating its interaction capability (Figure 2) (Oakley, et al., 2009). Competitive binding and conformational changes such as this may be responsible for many of the protein interactions that are altered upon phosphorylation of RPA2. Hyperphosphorylation abolishes interaction of RPA with DNA polymerase α , as well as decreases its duplex unwinding ability, which is critical for replication (Oakley, et al., 2003; Patrick, et al., 2005; Wold, 1997). Additionally, in an SV40 *in vitro* system, hyperphosphorylation of RPA leads to a 50% reduction in replication, which can be rescued by unphosphorylated RPA (Patrick, et al., 2005). Hyperphosphorylation, coupled with other aspects of the intra-S phase checkpoint, effectively halts chromosomal replication. However, other RPA-dependent processes, such as damage-dependent DNA synthesis, are unchanged or stimulated. Hyperphosphorylated RPA stimulates *in vivo* synthesis of DNA on RPA-coated ssDNA via a currently unidentified repair polymerase, minimizing ssDNA accumulation during replication stress (Vassin, et al., 2009). Additionally, essential interactions between RPA and NER proteins are unaffected by hyperphosphorylation of RPA (see above) (Oakley, et al., 2003; Patrick, et al., 2005). Many of these repair proteins are capable of interacting with the unphosphorylated C-terminus of RPA2 rather than the N-terminus of RPA1, which may explain the separation of functions between unphosphorylated and hyperphosphorylated RPA (Ali, et al., 2010; Saijo, et al., 2011). Regardless of the mechanism, this demonstrates the versatility of RPA in DNA metabolism.

The previous discussion has focused on a restart and repair pathway for replication fork stalls in which the replicative helicase uncouples from the replisome. A replisome may also encounter double-strand lesions, such as interstrand crosslinks, that prevent progression of the entire complex. These lesions, as well as some ssDNA lesions, result in stalled forks that may be repaired and restarted through fork regression. Among the most important proteins in fork regression are repair helicases including those in the RecQ, RecG, HARP, and FANC families. These helicases may perform the complex winding and unwinding of nascent and template strands necessary to form a Holliday junction-like structure referred to as a "chicken foot." Additionally, proteins of the Fanconi anemia pathway may be important for

RPA focus formation in regression of forks stalled by interstrand crosslinks (Huang, et al., 2010). For a review of fork regression models, see Atkinson and McGlynn, 2009.

Many studies support the hypothesis that RPA directs activity of helicases in fork regression. In eukaryotes, RPA interacts with the RecQ-like helicases WRN and BLM, which have been implicated in the regression of stalled replication forks *in vitro*. RecQ helicases are important for maintenance of chromosome stability; it is therefore not unexpected that they would be involved in fork regression. The interaction of RPA with these proteins may also recruit them to stalled forks; regardless, it stimulates their helicase activity (Brosh, et al., 2000; Brosh, et al., 1999; Doherty, et al., 2005; Machwe, et al., 2011; Machwe, et al., 2006; Machwe, et al., 2007; Ralf, et al., 2006). RPA also recruits the annealing helicase HARP to stalled forks through direct interaction. HARP has been implicated in stabilization and restart of stalled replication forks and may be well suited to assisting fork regression in which complementary DNA strands must be annealed to form stable structures (Ciccia, et al., 2009; Yuan, et al., 2009; Yusufzai, et al., 2009). Thus, the RecQ-like helicases may work with the HARP helicases in the regression of stalled forks. In addition to the human RecQ-like helicases, the archaeal RecQ-like helicase Hel308 is also recruited by RPA and is capable of fork regression *in vitro* (Li, et al., 2008; Woodman, et al., 2010). Additionally, the FANCM protein, which is involved in fork regression, interacts with RPA at stalled forks to promote formation of RPA foci (Banerjee, et al., 2008; Huang, et al., 2010).

In bacterial fork regression, similar interactions between SSB and helicases have been observed. SSB binds RecQ through its C-terminus *in vitro* and stimulates RecQ helicase activity (Lecointe, et al., 2007; Shereda, et al., 2007; Shereda, et al., 2008). RecG helicase not only interacts with SSB through the C-terminus but is stabilized by this interaction and supports fork regression (Buss, et al., 2008; Lecointe, et al., 2007; Shereda, et al., 2008). The replication restart helicase PriA also interacts with SSB, which would complete the fork regression process and initiate restart of replication (Cadman & McGlynn, 2004; Kozlov, et al., 2010; Lecointe, et al., 2007; Shereda, et al., 2008). In addition to helicases, SSB interacts with and actively directs the activity of several recombination proteins necessary for the repair of regressed forks before they may be restarted. These processes are essential to other aspects of DNA repair as well, including double-strand break (DSB) repair, discussed below.

5.4 Interactive role of RPA and SSB in DNA double-strand break repair

The types of DNA damage discussed previously may be repaired directly through NER or in response to replication fork stall. A far more grave form of DNA damage is the DSB, arising from either exogenous or endogenous stresses. A well-known exogenous physical stress that causes DSBs is IR, which is the major reason that it is so detrimental to living systems. A variety of chemical agents, such as bleomycin, phleomycin, and mitomycin C, also act by inducing DSBs. Additionally, a stalled replication fork that is unrepaired may collapse into a special type of DSB with a single double-strand end (Allen, et al., 2011). Regardless, these DSBs are all repaired via similar pathways, which rely on RPA and SSB.

Until recently, models of eukaryotic DSB repair indicated that the conserved DNA repair protein complex MRN (Mre11-Rad50-Nbs1) was the first responder and signaler at the site of a DSB. However, recent evidence implicates the novel ssDNA binding protein hSSB1 as the DSB-recognition protein in humans. At the site of damage this protein may bind short ssDNA overhangs and provide protection from incorrect end-processing by nucleases. Additionally, hSSB1 is found complexed with MRN independent of damage, through an

interaction between the C-terminal tail of hSSB1 and the N-terminal region of Nbs1. This direct interaction, along with the ssDNA-bound hSSB1, stimulates the recruitment of the MRN complex to DSB sites. RPA cannot replace hSSB1 in this function (Richard, Cubeddu, et al., 2011; Richard, Savage, et al., 2011). hSSB1 may also have duplex melting capabilities similar to that seen in other SSBs, which would further help to provide a substrate for MRN binding (Cubeddu & White, 2005; Eggington, et al., 2006; Richard, Cubeddu, et al., 2011).

Once recruited to a DSB, the MRN complex tethers the broken DNA ends; its endonuclease activity is stimulated through hSSB1 association. MRN then activates the ATM kinase, which in turn initiates a phosphorylation signal cascade similar to ATR. Among the many phosphorylation targets of ATM are the cell-cycle checkpoint kinase Chk2, histone variant H2AX, and hSSB1 (Czornak, et al., 2008; Richard, et al., 2008; Richard, Cubeddu, et al., 2011; Richard, Savage, et al., 2011; Williams, et al., 2010). Phosphorylation of Chk2 results in cell-cycle arrest, while phosphorylated H2AX serves as a local binding point for repair proteins (Kastan & Bartek, 2004; J. E. Kim, et al., 2006). hSSB1 phosphorylation has unknown consequences, but it is likely to alter its repair role in a manner similar to the phosphorylation of RPA (Richard, et al., 2008; Richard, Savage, et al., 2011). The nuclease activity of MRN results in limited end-resection at the DSB providing a substrate to which RPA may then bind (Richard, Cubeddu, et al., 2011; Richard, Savage, et al., 2011). ssDNA-bound RPA activates the ATR response and may also be phosphorylated by either activated ATM or ATR, switching it to a repair-process director (Jazayeri, et al., 2006; Oakley, et al., 2001).

In both eukaryotic and bacterial systems, DSB repair and fork regression may proceed via homologous recombination when a homologous template is present. Not surprisingly, RPA and SSB play central roles in this process as well. The RPA or SSB coating ssDNA at the site of damage is replaced with recombinase Rad51 or RecA, respectively, through direct interaction with mediators of homologous recombination. Specifically, the replacement of RPA by Rad51 is facilitated by interactions between the N-terminus of RPA1 and the homologous recombination mediator Rad52 (Plate, et al., 2008; Sugiyama & Kantake, 2009). Akin to requirements for ATR activation, multiple RPAs are necessary to promote this exchange. Similarly, bacterial SSB interacts through its C-terminal tail with the recombination mediator RecO to facilitate loading of RecA onto ssDNA by RecFOR (Costes, et al., 2010; Inoue, et al., 2011). Another interesting interaction of SSB is its apparent competition with the RecA inhibitor RecX for the common ssDNA ligand. By outcompeting RecX for access to ssDNA, SSB prevents RecX from inhibiting RecA loading onto the ssDNA (Baitin, et al., 2008). Interactions between archaeal SSB and a RadA-mediator Rad55 have also been demonstrated *in vitro*. This interaction promotes loading of RadA onto ssDNA suggesting a similar function to that seen in eukaryotes and bacteria (Sheng, et al., 2008).

6. Transcriptional regulation

The post-translational modifications of RPA/SSB provide virtually instantaneous response to conditions within the cell. Less well-documented, but potentially as important to survival, is transcriptional regulation of the genes in response to more global DNA damage. There is evidence of such regulation in all three domains of life. In general, where damage-induced transcriptional regulation has been reported, the organism contains multiple homologs, and the damage-regulated RPA is generally not required for replication.

In bacteria, the well-studied *E. coli* *ssb* gene contains multiple promoters, one of which has been shown to be damage-inducible (Brandsma, et al., 1985). Despite this, the level of *E. coli*

SSB protein does not appear to respond to DNA damage, suggesting that any regulation on this promoter is compensated by opposite regulation on the others (Meyer & Laine, 1990). One of the two homologs in *B. subtilis* functions in natural competence, whereas the gene for the replication SSB is not damage-inducible (Lindner, et al., 2004). The promoters for both the canonical SSB and the newly identified DdrB in *D. radiodurans* contain a recognizable “radiation-desiccation response motif”; both genes are up-regulated in response to IR, but *ssb* is not induced by desiccation or UV (Ujaoney, et al., 2010). The SSB protein is present in *D. radiodurans* at ten-fold higher levels than in *E. coli*, and, unlike in *E. coli*, levels increase 4-fold after irradiation (Bernstein, et al., 2004; Y. Liu, et al., 2003). In contrast, the transcript for the *ddrB* gene is normally almost absent, but is induced 40-fold within minutes after exposure to IR (Tanaka, et al., 2004). The IR-sensitivity, and viability, of *ddrB* knockouts underscores its specific role in DNA repair, and not replication.

In yeast and humans, the presence of a single RPA makes transcriptional regulation in response to damage less likely. In yeast, expression of RPA is cell-cycle dependent, with maximal expression prior to S phase (Brill & Stillman, 1991). Human RPA levels remain constant throughout the cell cycle (Wold, 1997). However, the alternative RPA2 subunit, RPA4, is more highly expressed in quiescent cells, and, since it competes with RPA2 for binding to RPA1 and RPA3, must be down-regulated in dividing cells (Haring, et al., 2010). This long-term regulation, however, is presumably not readily reversible, and is not a damage response. Interestingly, RPA1 and RPA2 levels are higher in colon cancer cells but it is not clear how this increase is achieved (Givalos, et al., 2007). Plants have multiple homologs, which are differentially expressed in tissues. There is evidence for regulation of certain homologs in response to DNA damage, as well as in response to certain hormones (Marwedel, et al., 2003; Sakaguchi, et al., 2009).

The single crenarchaeal RPA homolog would not be expected to be transcriptionally regulated to any significant extent, given its essential role in replication. In the euryarchaea, however, where multiple homologs are common, regulation has been reported. The transcriptome of *H. salinarum* during recovery from exposure to IR or UV has been analyzed and only one of the five RPA homologs showed any increase in expression (Baliga, et al., 2004; Kottemann, et al., 2005; McCready, et al., 2005). This homolog, encoded by the *rfa3* operon, is one of two eukaryotic-like RPAs present in *H. salinarum*. Constitutive up-regulation of this operon was found as the only transcriptomic difference among multiple radiation-resistant mutants of *H. salinarum* (DeVeaux, et al., 2007). This homolog is significantly up-regulated following IR-treatment of wild type *H. salinarum*, but not in the radiation-resistant mutants, presumably because the protein is being constitutively expressed at the induced level. In addition, both wild-type and mutant strains show induced expression of the second RPA-like homolog, encoded by the *rfa2* operon. Neither of the crenarchaeal nor the euryarchaeal-like SSB/RPA homologs shows significant transcriptional differences after irradiation (Gygli and DeVeaux, unpublished observations). These results suggest that the eukaryotic RPA-like homologs present in this organism may be more directly involved in repair of radiation damage.

7. Conclusion

The highly conserved and essential nature of the RPA/SSB family underscores the fundamental role that these proteins play in basic DNA metabolic processes. The interactions that these proteins are involved in illustrate an intricate network and temporal

sequence of events that are only beginning to be understood. The multiplicity of homologs present in some lineages suggests that ancestral duplications have resulted in specialization of function. These organisms provide models for study of individual activities, such as DNA repair, which are not essential for viability.

8. Acknowledgment

We thank all of the researchers whose hard work provided us with material for this review. We thank Dr. Dring Crowell and the members of the DeVaux lab for support and helpful comments. The following agencies provided support for P.E.G. and J.S.L.: The Henry M. Jackson Foundation, NASA ISGC, and The United States Department of Defense.

9. References

- Ali, S. I., Shin, J. S., Bae, S. H., et al. (2010). Replication Protein A 32 interacts through a similar binding interface with TIPIN, XPA, and UNG2. *Int J Biochem Cell Biol*, Vol. 42, No. 7 (pp. 1210-1215), 1878-5875 (Electronic) 1357-2725 (Linking)
- Allen, C., Ashley, A. K., Hromas, R., et al. (2011). More forks on the road to replication stress recovery. *J Mol Cell Biol*, Vol. 3, No. 1 (pp. 4-12), 1759-4685 (Electronic)
- Anantha, R. W., Vassin, V. M., & Borowiec, J. A. (2007). Sequential and synergistic modification of human RPA stimulates chromosomal DNA repair. *J Biol Chem*, Vol. 282, No. 49 (pp. 35910-35923), 0021-9258 (Print) 0021-9258 (Linking)
- Atkinson, J., & McGlynn, P. (2009). Replication fork reversal and the maintenance of genome stability. *Nucleic Acids Res*, Vol. 37, No. 11 (pp. 3475-3492), 1362-4962 (Electronic) 0305-1048 (Linking)
- Baitin, D. M., Gruenig, M. C., & Cox, M. M. (2008). SSB antagonizes RecX-RecA interaction. *J Biol Chem*, Vol. 283, No. 21 (pp. 14198-14204), 0021-9258 (Print) 0021-9258 (Linking)
- Baliga, N. S., Bjork, S. J., Bonneau, R., et al. (2004). Systems level insights into the stress response to UV radiation in the halophilic archaeon *Halobacterium* NRC-1. *Genome Res*, Vol. 14, No. 6 (pp. 1025-1035), 1088-9051 (Print) 1088-9051 (Linking)
- Banerjee, S., Smith, S., Oum, J. H., et al. (2008). Mph1p promotes gross chromosomal rearrangement through partial inhibition of homologous recombination. *J Cell Biol*, Vol. 181, No. 7 (pp. 1083-1093), 1540-8140 (Electronic) 0021-9525 (Linking)
- Bernstein, D. A., Eggington, J. M., Killoran, M. P., et al. (2004). Crystal structure of the *Deinococcus radiodurans* single-stranded DNA-binding protein suggests a mechanism for coping with DNA damage. *Proc Natl Acad Sci U S A*, Vol. 101, No. 23 (pp. 8575-8580), 0027-8424 (Print) 0027-8424 (Linking)
- Binz, S. K., Dickson, A. M., Haring, S. J., et al. (2006). Functional assays for Replication Protein A (RPA). *Methods Enzymol*, Vol. 409, (pp. 11-38), 0076-6879 (Print) 0076-6879 (Linking)
- Binz, S. K., Sheehan, A. M., & Wold, M. S. (2004). Replication Protein A phosphorylation and the cellular response to DNA damage. *DNA Repair (Amst)*, Vol. 3, No. 8-9 (pp. 1015-1024), 1568-7864 (Print) 1568-7856 (Linking)
- Blackwell, L. J., & Borowiec, J. A. (1994). Human Replication Protein A binds single-stranded DNA in two distinct complexes. *Mol Cell Biol*, Vol. 14, No. 6 (pp. 3993-4001), 0270-7306 (Print) 0270-7306 (Linking)

- Brandsma, J. A., Bosch, D., de Ruyter, M., et al. (1985). Analysis of the regulatory region of the *ssb* gene of *Escherichia coli*. *Nucleic Acids Res*, Vol. 13, No. 14 (pp. 5095-5109), 0305-1048 (Print) 0305-1048 (Linking)
- Brill, S. J., & Stillman, B. (1991). Replication factor-A from *Saccharomyces cerevisiae* is encoded by three essential genes coordinately expressed at S phase. *Genes Dev*, Vol. 5, No. 9 (pp. 1589-1600), 0890-9369 (Print) 0890-9369 (Linking)
- Broderick, S., Rehmert, K., Concannon, C., et al. (2010). Eukaryotic single-stranded DNA binding proteins: central factors in genome stability. *Subcell Biochem*, Vol. 50, (pp. 143-163), 0306-0225 (Print) 0306-0225 (Linking)
- Brosh, R. M., Jr., Li, J. L., Kenny, M. K., et al. (2000). Replication Protein A physically interacts with the Bloom's syndrome protein and stimulates its helicase activity. *J Biol Chem*, Vol. 275, No. 31 (pp. 23500-23508), 0021-9258 (Print) 0021-9258 (Linking)
- Brosh, R. M., Jr., Orren, D. K., Nehlin, J. O., et al. (1999). Functional and physical interaction between WRN helicase and human Replication Protein A. *J Biol Chem*, Vol. 274, No. 26 (pp. 18341-18350), 0021-9258 (Print) 0021-9258 (Linking)
- Buss, J. A., Kimura, Y., & Bianco, P. R. (2008). RecG interacts directly with SSB: implications for stalled replication fork regression. *Nucleic Acids Res*, Vol. 36, No. 22 (pp. 7029-7042), 1362-4962 (Electronic) 0305-1048 (Linking)
- Byun, T. S., Pacek, M., Yee, M. C., et al. (2005). Functional uncoupling of MCM helicase and DNA polymerase activities activates the ATR-dependent checkpoint. *Genes Dev*, Vol. 19, No. 9 (pp. 1040-1052), 0890-9369 (Print) 0890-9369 (Linking)
- Cadman, C. J., & McGlynn, P. (2004). PriA helicase and SSB interact physically and functionally. *Nucleic Acids Res*, Vol. 32, No. 21 (pp. 6378-6387), 1362-4962 (Electronic) 0305-1048 (Linking)
- Cavero, S., Limbo, O., & Russell, P. (2010). Critical functions of Rpa3/Ssb3 in S-phase DNA damage responses in fission yeast. *PLoS Genet*, Vol. 6, No. 9, 1553-7404 (Electronic) 1553-7390 (Linking)
- Chang, Y., Gong, L., Yuan, W., et al. (2009). Replication Protein A (RPA1a) is required for meiotic and somatic DNA repair but is dispensable for DNA replication and homologous recombination in rice. *Plant Physiol*, Vol. 151, No. 4 (pp. 2162-2173), 1532-2548 (Electronic) 0032-0889 (Linking)
- Chase, J. W., L'Italien, J. J., Murphy, J. B., et al. (1984). Characterization of the *Escherichia coli* SSB-113 mutant single-stranded DNA-binding protein. Cloning of the gene, DNA and protein sequence analysis, high pressure liquid chromatography peptide mapping, and DNA-binding studies. *J Biol Chem*, Vol. 259, No. 2 (pp. 805-814), 0021-9258 (Print) 0021-9258 (Linking)
- Chedin, F., Seitz, E. M., & Kowalczykowski, S. C. (1998). Novel homologs of Replication Protein A in archaea: implications for the evolution of ssDNA-binding proteins. *Trends Biochem Sci*, Vol. 23, No. 8 (pp. 273-277), 0968-0004 (Print) 0968-0004 (Linking)
- Chen, C., & Kolodner, R. D. (1999). Gross chromosomal rearrangements in *Saccharomyces cerevisiae* replication and recombination defective mutants. *Nat Genet*, Vol. 23, No. 1 (pp. 81-85), 1061-4036 (Print) 1061-4036 (Linking)
- Chen, C., Umez, K., & Kolodner, R. D. (1998). Chromosomal rearrangements occur in *S. cerevisiae rfa1* mutator mutants due to mutagenic lesions processed by double-

- strand-break repair. *Mol Cell*, Vol. 2, No. 1 (pp. 9-22), 1097-2765 (Print) 1097-2765 (Linking)
- Ciccia, A., Bredemeyer, A. L., Sowa, M. E., et al. (2009). The SIOD disorder protein SMARCAL1 is an RPA-interacting protein involved in replication fork restart. *Genes Dev*, Vol. 23, No. 20 (pp. 2415-2425), 1549-5477 (Electronic) 0890-9369 (Linking)
- Cimprich, K. A., & Cortez, D. (2008). ATR: an essential regulator of genome integrity. *Nat Rev Mol Cell Biol*, Vol. 9, No. 8 (pp. 616-627), 1471-0080 (Electronic) 1471-0072 (Linking)
- Costes, A., Lecointe, F., McGovern, S., et al. (2010). The C-terminal domain of the bacterial SSB protein acts as a DNA maintenance hub at active chromosome replication forks. *PLoS Genet*, Vol. 6, No. 12 (pp. e1001238), 1553-7404 (Electronic) 1553-7390 (Linking)
- Cubeddu, L., & White, M. F. (2005). DNA damage detection by an archaeal single-stranded DNA-binding protein. *J Mol Biol*, Vol. 353, No. 3 (pp. 507-516), 0022-2836 (Print) 0022-2836 (Linking)
- Curth, U., Genschel, J., Urbanke, C., et al. (1996). *In vitro* and *in vivo* function of the C-terminus of *Escherichia coli* single-stranded DNA binding protein. *Nucleic Acids Res*, Vol. 24, No. 14 (pp. 2706-2711), 0305-1048 (Print) 0305-1048 (Linking)
- Curth, U., Urbanke, C., Greipel, J., et al. (1994). Single-stranded-DNA-binding proteins from human mitochondria and *Escherichia coli* have analogous physicochemical properties. *Eur J Biochem*, Vol. 221, No. 1 (pp. 435-443), 0014-2956 (Print) 0014-2956 (Linking)
- Czornak, K., Chughtai, S., & Chrzanowska, K. H. (2008). Mystery of DNA repair: the role of the MRN complex and ATM kinase in DNA damage repair. *J Appl Genet*, Vol. 49, No. 4 (pp. 383-396), 1234-1983 (Print) 1234-1283 (Linking)
- DeVeaux, L. C., Muller, J. A., Smith, J., et al. (2007). Extremely Radiation-Resistant Mutants of a Halophilic Archaeon with Increased Single-Stranded DNA-Binding Protein (RPA) Gene Expression. *Radiat Res*, Vol. 168, No. 4 (pp. 507-514), 0033-7587 (Print) 0033-7587 (Linking)
- Dickson, A. M., Krasikova, Y., Pestryakov, P., et al. (2009). Essential functions of the 32 kDa subunit of yeast Replication Protein A. *Nucleic Acids Res*, Vol. 37, No. 7 (pp. 2313-2326), 1362-4962 (Electronic) 0305-1048 (Linking)
- Dodson, G. E., Shi, Y., & Tibbetts, R. S. (2004). DNA replication defects, spontaneous DNA damage, and ATM-dependent checkpoint activation in Replication Protein A-deficient cells. *J Biol Chem*, Vol. 279, No. 32 (pp. 34010-34014), 0021-9258 (Print) 0021-9258 (Linking)
- Doherty, K. M., Sommers, J. A., Gray, M. D., et al. (2005). Physical and functional mapping of the Replication Protein A interaction domain of the Werner and Bloom syndrome helicases. *J Biol Chem*, Vol. 280, No. 33 (pp. 29494-29505), 0021-9258 (Print) 0021-9258 (Linking)
- Dronkert, M. L., & Kanaar, R. (2001). Repair of DNA interstrand cross-links. *Mutat Res*, Vol. 486, No. 4 (pp. 217-247), 0027-5107 (Print) 0027-5107 (Linking)
- Eggington, J. M., Haruta, N., Wood, E. A., et al. (2004). The single-stranded DNA-binding protein of *Deinococcus radiodurans*. *BMC Microbiol*, Vol. 4, (pp. 2), 1471-2180 (Electronic) 1471-2180 (Linking)

- Eggington, J. M., Kozlov, A. G., Cox, M. M., et al. (2006). Polar destabilization of DNA duplexes with single-stranded overhangs by the *Deinococcus radiodurans* SSB protein. *Biochemistry*, Vol. 45, No. 48 (pp. 14490-14502), 0006-2960 (Print) 0006-2960 (Linking)
- Fanning, E., Klimovich, V., & Nager, A. R. (2006). A dynamic model for Replication Protein A (RPA) function in DNA processing pathways. *Nucleic Acids Res*, Vol. 34, No. 15 (pp. 4126-4137), 1362-4962 (Electronic) 0305-1048 (Linking)
- Filipkowski, P., Duraj-Thatte, A., & Kur, J. (2006). Novel thermostable single-stranded DNA-binding protein (SSB) from *Deinococcus geothermalis*. *Arch Microbiol*, Vol. 186, No. 2 (pp. 129-137), 0302-8933 (Print) 0302-8933 (Linking)
- Filipkowski, P., & Kur, J. (2007). Identification and properties of the *Deinococcus grandis* and *Deinococcus proteolyticus* single-stranded DNA binding proteins (SSB). *Acta Biochim Pol*, Vol. 54, No. 1 (pp. 79-87), 0001-527X (Print) 0001-527X (Linking)
- Genschel, J., Curth, U., & Urbanke, C. (2000). Interaction of *E. coli* single-stranded DNA binding protein (SSB) with exonuclease I. The carboxy-terminus of SSB is the recognition site for the nuclease. *Biol Chem*, Vol. 381, No. 3 (pp. 183-192), 1431-6730 (Print) 1431-6730 (Linking)
- Genschel, J., & Modrich, P. (2009). Functions of MutL α , Replication Protein A (RPA), and HMGB1 in 5'-directed mismatch repair. *J Biol Chem*, Vol. 284, No. 32 (pp. 21536-21544), 0021-9258 (Print) 0021-9258 (Linking)
- Georgaki, A., & Hubscher, U. (1993). DNA unwinding by Replication Protein A is a property of the 70 kDa subunit and is facilitated by phosphorylation of the 32 kDa subunit. *Nucleic Acids Res*, Vol. 21, No. 16 (pp. 3659-3665), 0305-1048 (Print) 0305-1048 (Linking)
- Georgaki, A., Strack, B., Podust, V., et al. (1992). DNA unwinding activity of Replication Protein A. *FEBS Lett*, Vol. 308, No. 3 (pp. 240-244), 0014-5793 (Print) 0014-5793 (Linking)
- Givalos, N., Gakiopoulou, H., Skliri, M., et al. (2007). Replication Protein A is an independent prognostic indicator with potential therapeutic implications in colon cancer. *Mod Pathol*, Vol. 20, No. 2 (pp. 159-166), 0893-3952 (Print) 0893-3952 (Linking)
- Haring, S. J., Humphreys, T. D., & Wold, M. S. (2010). A naturally occurring human RPA subunit homolog does not support DNA replication or cell-cycle progression. *Nucleic Acids Res*, Vol. 38, No. 3 (pp. 846-858), 1362-4962 (Electronic) 0305-1048 (Linking)
- Haring, S. J., Mason, A. C., Binz, S. K., et al. (2008). Cellular functions of human RPA1. Multiple roles of domains in replication, repair, and checkpoints. *J Biol Chem*, Vol. 283, No. 27 (pp. 19095-19111), 0021-9258 (Print) 0021-9258 (Linking)
- Haseltine, C. A., & Kowalczykowski, S. C. (2002). A distinctive single-strand DNA-binding protein from the Archaeon *Sulfolobus solfataricus*. *Mol Microbiol*, Vol. 43, No. 6 (pp. 1505-1515), 0950-382X (Print) 0950-382X (Linking)
- Hass, C. S., Gakhar, L., & Wold, M. S. (2010). Functional characterization of a cancer causing mutation in human Replication Protein A. *Mol Cancer Res*, Vol. 8, No. 7 (pp. 1017-1026), 1557-3125 (Electronic) 1541-7786 (Linking)
- Henricksen, L. A., Carter, T., Dutta, A., et al. (1996). Phosphorylation of human Replication Protein A by the DNA-dependent protein kinase is involved in the modulation of

- DNA replication. *Nucleic Acids Res*, Vol. 24, No. 15 (pp. 3107-3112), 0305-1048 (Print) 0305-1048 (Linking)
- Huang, M., Kim, J. M., Shiotani, B., et al. (2010). The FANCM/FAAP24 complex is required for the DNA interstrand crosslink-induced checkpoint response. *Mol Cell*, Vol. 39, No. 2 (pp. 259-268), 1097-4164 (Electronic) 1097-2765 (Linking)
- Iftode, C., Daniely, Y., & Borowiec, J. A. (1999). Replication Protein A (RPA): the eukaryotic SSB. *Crit Rev Biochem Mol Biol*, Vol. 34, No. 3 (pp. 141-180), 1040-9238 (Print) 1040-9238 (Linking)
- Inoue, J., Nagae, T., Mishima, M., et al. (2011). A Mechanism for Single-stranded DNA-binding Protein (SSB) Displacement from Single-stranded DNA upon SSB-RecO Interaction. *J Biol Chem*, Vol. 286, No. 8 (pp. 6720-6732), 1083-351X (Electronic) 0021-9258 (Linking)
- Ishibashi, T., Kimura, S., & Sakaguchi, K. (2006). A higher plant has three different types of RPA heterotrimeric complex. *J Biochem*, Vol. 139, No. 1 (pp. 99-104), 0021-924X (Print) 0021-924X (Linking)
- Jazayeri, A., Falck, J., Lukas, C., et al. (2006). ATM- and cell cycle-dependent regulation of ATR in response to DNA double-strand breaks. *Nat Cell Biol*, Vol. 8, No. 1 (pp. 37-45), 1465-7392 (Print) 1465-7392 (Linking)
- Kastan, M. B., & Bartek, J. (2004). Cell-cycle checkpoints and cancer. *Nature*, Vol. 432, No. 7015 (pp. 316-323), 1476-4687 (Electronic) 0028-0836 (Linking)
- Kelly, T. J., Simancek, P., & Brush, G. S. (1998). Identification and characterization of a single-stranded DNA-binding protein from the archaeon *Methanococcus jannaschii*. *Proc Natl Acad Sci U S A*, Vol. 95, No. 25 (pp. 14634-14639), 0027-8424 (Print) 0027-8424 (Linking)
- Kerr, I. D., Wadsworth, R. I., Blankenfeldt, W., et al. (2001). Overexpression, purification, crystallization and data collection of a single-stranded DNA-binding protein from *Sulfolobus solfataricus*. *Acta Crystallogr D Biol Crystallogr*, Vol. 57, No. Pt 9 (pp. 1290-1292), 0907-4449 (Print) 0907-4449 (Linking)
- Kerr, I. D., Wadsworth, R. I., Cubeddu, L., et al. (2003). Insights into ssDNA recognition by the OB fold from a structural and thermodynamic study of *Sulfolobus* SSB protein. *EMBO J*, Vol. 22, No. 11 (pp. 2561-2570), 0261-4189 (Print) 0261-4189 (Linking)
- Keshav, K. F., Chen, C., & Dutta, A. (1995). Rpa4, a homolog of the 34-kilodalton subunit of the Replication Protein A complex. *Mol Cell Biol*, Vol. 15, No. 6 (pp. 3119-3128), 0270-7306 (Print) 0270-7306 (Linking)
- Kim, C., Snyder, R. O., & Wold, M. S. (1992). Binding properties of Replication Protein A from human and yeast cells. *Mol Cell Biol*, Vol. 12, No. 7 (pp. 3050-3059), 0270-7306 (Print) 0270-7306 (Linking)
- Kim, H. S., & Brill, S. J. (2001). Rfc4 interacts with Rpa1 and is required for both DNA replication and DNA damage checkpoints in *Saccharomyces cerevisiae*. *Mol Cell Biol*, Vol. 21, No. 11 (pp. 3725-3737), 0270-7306 (Print) 0270-7306 (Linking)
- Kim, J. E., Minter-Dykhouse, K., & Chen, J. (2006). Signaling networks controlled by the MRN complex and MDC1 during early DNA damage responses. *Mol Carcinog*, Vol. 45, No. 6 (pp. 403-408), 0899-1987 (Print) 0899-1987 (Linking)
- Kobayashi, Y., Sato, K., Kibe, T., et al. (2010). Expression of mutant RPA in human cancer cells causes telomere shortening. *Biosci Biotechnol Biochem*, Vol. 74, No. 2 (pp. 382-385), 1347-6947 (Electronic) 0916-8451 (Linking)

- Komori, K., & Ishino, Y. (2001). Replication Protein A in *Pyrococcus furiosus* is involved in homologous DNA recombination. *J Biol Chem*, Vol. 276, No. 28 (pp. 25654-25660), 0021-9258 (Print) 0021-9258 (Linking)
- Kottemann, M., Kish, A., Iloanusi, C., et al. (2005). Physiological responses of the halophilic archaeon *Halobacterium* sp. strain NRC1 to desiccation and gamma irradiation. *Extremophiles*, Vol. 9, No. 3 (pp. 219-227), 1431-0651 (Print) 1431-0651 (Linking)
- Kozlov, A. G., Jezewska, M. J., Bujalowski, W., et al. (2010). Binding specificity of *Escherichia coli* single-stranded DNA binding protein for the chi subunit of DNA pol III holoenzyme and PriA helicase. *Biochemistry*, Vol. 49, No. 17 (pp. 3555-3566), 1520-4995 (Electronic) 0006-2960 (Linking)
- Krasikova, Y. S., Rechkunova, N. I., Maltseva, E. A., et al. (2010). Localization of xeroderma pigmentosum group A protein and Replication Protein A on damaged DNA in nucleotide excision repair. *Nucleic Acids Res*, Vol. 38, No. 22 (pp. 8083-8094), 1362-4962 (Electronic) 0305-1048 (Linking)
- Krokan, H. E., Nilsen, H., Skorpen, F., et al. (2000). Base excision repair of DNA in mammalian cells. *FEBS Lett*, Vol. 476, No. 1-2 (pp. 73-77), 0014-5793 (Print) 0014-5793 (Linking)
- Kumar, N. V., & Varshney, U. (1997). Contrasting effects of single stranded DNA binding protein on the activity of uracil DNA glycosylase from *Escherichia coli* towards different DNA substrates. *Nucleic Acids Res*, Vol. 25, No. 12 (pp. 2336-2343), 0305-1048 (Print) 0305-1048 (Linking)
- Lecointe, F., Serena, C., Velten, M., et al. (2007). Anticipating chromosomal replication fork arrest: SSB targets repair DNA helicases to active forks. *EMBO J*, Vol. 26, No. 19 (pp. 4239-4251), 0261-4189 (Print) 0261-4189 (Linking)
- Li, Z., Lu, S., Hou, G., et al. (2008). Hjm/Hel308A DNA helicase from *Sulfolobus tokodaii* promotes replication fork regression and interacts with Hjc endonuclease *in vitro*. *J Bacteriol*, Vol. 190, No. 8 (pp. 3006-3017), 1098-5530 (Electronic) 0021-9193 (Linking)
- Lin, Y., Lin, L. J., Sriratana, P., et al. (2008). Engineering of functional Replication Protein A homologs based on insights into the evolution of oligonucleotide/oligosaccharide-binding folds. *J Bacteriol*, Vol. 190, No. 17 (pp. 5766-5780), 1098-5530 (Electronic) 0021-9193 (Linking)
- Lin, Y., Robbins, J. B., Nyannor, E. K., et al. (2005). A CCCH zinc finger conserved in a Replication Protein A homolog found in diverse Euryarchaeotes. *J Bacteriol*, Vol. 187, No. 23 (pp. 7881-7889), 0021-9193 (Print) 0021-9193 (Linking)
- Lindner, C., Nijland, R., van Hartskamp, M., et al. (2004). Differential expression of two paralogous genes of *Bacillus subtilis* encoding single-stranded DNA binding protein. *J Bacteriol*, Vol. 186, No. 4 (pp. 1097-1105), 0021-9193 (Print) 0021-9193 (Linking)
- Liu, J. S., Kuo, S. R., & Melendy, T. (2006). Phosphorylation of Replication Protein A by S-phase checkpoint kinases. *DNA Repair (Amst)*, Vol. 5, No. 3 (pp. 369-380), 1568-7864 (Print) 1568-7856 (Linking)
- Liu, Y., Zhou, J., Omelchenko, M. V., et al. (2003). Transcriptome dynamics of *Deinococcus radiodurans* recovering from ionizing radiation. *Proc Natl Acad Sci U S A*, Vol. 100, No. 7 (pp. 4191-4196), 0027-8424 (Print) 0027-8424 (Linking)

- Lohman, T. M., & Ferrari, M. E. (1994). *Escherichia coli* single-stranded DNA-binding protein: multiple DNA-binding modes and cooperativities. *Annu Rev Biochem*, Vol. 63, (pp. 527-570), 0066-4154 (Print) 0066-4154 (Linking)
- Longhese, M. P., Neecke, H., Paciotti, V., et al. (1996). The 70 kDa subunit of Replication Protein A is required for the G1/S and intra-S DNA damage checkpoints in budding yeast. *Nucleic Acids Res*, Vol. 24, No. 18 (pp. 3533-3537), 0305-1048 (Print) 0305-1048 (Linking)
- Lu, D., & Keck, J. L. (2008). Structural basis of *Escherichia coli* single-stranded DNA-binding protein stimulation of exonuclease I. *Proc Natl Acad Sci U S A*, Vol. 105, No. 27 (pp. 9169-9174), 1091-6490 (Electronic) 0027-8424 (Linking)
- Luo, X., Schwarz-Linek, U., Botting, C. H., et al. (2007). CC1, a novel crenarchaeal DNA binding protein. *J Bacteriol*, Vol. 189, No. 2 (pp. 403-409), 0021-9193 (Print) 0021-9193 (Linking)
- Machwe, A., Lozada, E., Wold, M. S., et al. (2011). Molecular cooperation between the Werner syndrome protein and Replication Protein A in relation to replication fork blockage. *J Biol Chem*, Vol. 286, No. 5 (pp. 3497-3508), 1083-351X (Electronic) 021-9258 (Linking)
- Machwe, A., Xiao, L., Groden, J., et al. (2006). The Werner and Bloom syndrome proteins catalyze regression of a model replication fork. *Biochemistry*, Vol. 45, No. 47 (pp. 13939-13946), 0006-2960 (Print) 0006-2960 (Linking)
- Machwe, A., Xiao, L., Lloyd, R. G., et al. (2007). Replication fork regression *in vitro* by the Werner syndrome protein (WRN): holliday junction formation, the effect of leading arm structure and a potential role for WRN exonuclease activity. *Nucleic Acids Res*, Vol. 35, No. 17 (pp. 5729-5747), 1362-4962 (Electronic) 0305-1048 (Linking)
- Majka, J., Binz, S. K., Wold, M. S., et al. (2006). Replication Protein A directs loading of the DNA damage checkpoint clamp to 5'-DNA junctions. *J Biol Chem*, Vol. 281, No. 38 (pp. 27855-27861), 0021-9258 (Print) 0021-9258 (Linking)
- Maniar, H. S., Wilson, R., & Brill, S. J. (1997). Roles of Replication Protein-A subunits 2 and 3 in DNA replication fork movement in *Saccharomyces cerevisiae*. *Genetics*, Vol. 145, No. 4 (pp. 891-902), 0016-6731 (Print) 0016-6731 (Linking)
- Marwedel, T., Ishibashi, T., Lorbiecke, R., et al. (2003). Plant-specific regulation of Replication Protein A2 (OsRPA2) from rice during the cell cycle and in response to ultraviolet light exposure. *Planta*, Vol. 217, No. 3 (pp. 457-465), 0032-0935 (Print) 0032-0935 (Linking)
- Mason, A. C., Haring, S. J., Pryor, J. M., et al. (2009). An alternative form of Replication Protein A prevents viral replication *in vitro*. *J Biol Chem*, Vol. 284, No. 8 (pp. 5324-5331), 0021-9258 (Print) 0021-9258 (Linking)
- Mason, A. C., Roy, R., Simmons, D. T., et al. (2010). Functions of alternative Replication Protein A in initiation and elongation. *Biochemistry*, Vol. 49, No. 28 (pp. 5919-5928), 1520-4995 (Electronic) 0006-2960 (Linking)
- McCready, S., Muller, J. A., Boubriak, I., et al. (2005). UV irradiation induces homologous recombination genes in the model archaeon, *Halobacterium* sp. NRC-1. *Saline Systems*, Vol. 1, (pp. 3)
- McInerney, P., & O'Donnell, M. (2007). Replisome fate upon encountering a leading strand block and clearance from DNA by recombination proteins. *J Biol Chem*, Vol. 282, No. 35 (pp. 25903-25916), 0021-9258 (Print) 0021-9258 (Linking)

- Mer, G., Bochkarev, A., Gupta, R., et al. (2000). Structural basis for the recognition of DNA repair proteins UNG2, XPA, and RAD52 by replication factor RPA. *Cell*, Vol. 103, No. 3 (pp. 449-456), 0092-8674 (Print) 0092-8674 (Linking)
- Meyer, R. R., & Laine, P. S. (1990). The single-stranded DNA-binding protein of *Escherichia coli*. *Microbiol Rev*, Vol. 54, No. 4 (pp. 342-380), 0146-0749 (Print) 0146-0749 (Linking)
- Mijakovic, I., Petranovic, D., Macek, B., et al. (2006). Bacterial single-stranded DNA-binding proteins are phosphorylated on tyrosine. *Nucleic Acids Res*, Vol. 34, No. 5 (pp. 1588-1596), 1362-4962 (Electronic) 0305-1048 (Linking)
- Naue, N., Fedorov, R., Pich, A., et al. (2011). Site-directed mutagenesis of the χ subunit of DNA polymerase III and single-stranded DNA-binding protein of *E. coli* reveals key residues for their interaction. *Nucleic Acids Res*, Vol. 39, No. 4 (pp. 1398-1407), 1362-4962 (Electronic) 0305-1048 (Linking)
- Norais, C. A., Chitteni-Pattu, S., Wood, E. A., et al. (2009). DdrB protein, an alternative *Deinococcus radiodurans* SSB induced by ionizing radiation. *J Biol Chem*, Vol. 284, No. 32 (pp. 21402-21411), 0021-9258 (Print) 0021-9258 (Linking)
- Nuss, J. E., Patrick, S. M., Oakley, G. G., et al. (2005). DNA damage induced hyperphosphorylation of Replication Protein A. 1. Identification of novel sites of phosphorylation in response to DNA damage. *Biochemistry*, Vol. 44, No. 23 (pp. 8428-8437), 0006-2960 (Print) 0006-2960 (Linking)
- Oakley, G. G., Loberg, L. I., Yao, J., et al. (2001). UV-induced hyperphosphorylation of Replication Protein A depends on DNA replication and expression of ATM protein. *Mol Biol Cell*, Vol. 12, No. 5 (pp. 1199-1213), 1059-1524 (Print) 1059-1524 (Linking)
- Oakley, G. G., Patrick, S. M., Yao, J., et al. (2003). RPA phosphorylation in mitosis alters DNA binding and protein-protein interactions. *Biochemistry*, Vol. 42, No. 11 (pp. 3255-3264), 0006-2960 (Print) 0006-2960 (Linking)
- Oakley, G. G., Tillison, K., Opiyo, S. A., et al. (2009). Physical interaction between Replication Protein A (RPA) and MRN: involvement of RPA2 phosphorylation and the N-terminus of RPA1. *Biochemistry*, Vol. 48, No. 31 (pp. 7473-7481), 1520-4995 (Electronic) 0006-2960 (Linking)
- Olszewski, M., Grot, A., Wojciechowski, M., et al. (2010). Characterization of exceptionally thermostable single-stranded DNA-binding proteins from *Thermotoga maritima* and *Thermotoga neapolitana*. *BMC Microbiol*, Vol. 10, (pp. 260), 1471-2180 (Electronic) 1471-2180 (Linking)
- Olszewski, M., Mickiewicz, M., & Kur, J. (2008). Two highly thermostable paralogous single-stranded DNA-binding proteins from *Thermoanaerobacter tengcongensis*. *Arch Microbiol*, Vol. 190, No. 1 (pp. 79-87), 0302-8933 (Print) 0302-8933 (Linking)
- Ono, Y., Tomita, K., Matsuura, A., et al. (2003). A novel allele of fission yeast *rad11* that causes defects in DNA repair and telomere length regulation. *Nucleic Acids Res*, Vol. 31, No. 24 (pp. 7141-7149), 1362-4962 (Electronic) 0305-1048 (Linking)
- Osman, K., Sanchez-Moran, E., Mann, S. C., et al. (2009). Replication protein A (AtRPA1a) is required for class I crossover formation but is dispensable for meiotic DNA break repair. *EMBO J*, Vol. 28, No. 4 (pp. 394-404), 1460-2075 (Electronic) 0261-4189 (Linking)
- Overmeer, R. M., Moser, J., Volker, M., et al. (2011). Replication Protein A safeguards genome integrity by controlling NER incision events. *J Cell Biol*, Vol. 192, No. 3 (pp. 401-415), 1540-8140 (Electronic) 0021-9525 (Linking)

- Pages, V., & Fuchs, R. P. (2003). Uncoupling of leading- and lagging-strand DNA replication during lesion bypass *in vivo*. *Science*, Vol. 300, No. 5623 (pp. 1300-1303), 1095-9203 (Electronic) 0036-8075 (Linking)
- Pan, Z. Q., Park, C. H., Amin, A. A., et al. (1995). Phosphorylated and unphosphorylated forms of human single-stranded DNA-binding protein are equally active in simian virus 40 DNA replication and in nucleotide excision repair. *Proc Natl Acad Sci U S A*, Vol. 92, No. 10 (pp. 4636-4640), 0027-8424 (Print) 0027-8424 (Linking)
- Parker, A. E., Clyne, R. K., Carr, A. M., et al. (1997). The *Schizosaccharomyces pombe rad11+* gene encodes the large subunit of Replication Protein A. *Mol Cell Biol*, Vol. 17, No. 5 (pp. 2381-514), 0270-7306 (Print) 0270-7306 (Linking)
- Patrick, S. M., Oakley, G. G., Dixon, K., et al. (2005). DNA damage induced hyperphosphorylation of Replication Protein A. 2. Characterization of DNA binding activity, protein interactions, and activity in DNA replication and repair. *Biochemistry*, Vol. 44, No. 23 (pp. 8438-8448), 0006-2960 (Print) 0006-2960 (Linking)
- Philipova, D., Mullen, J. R., Maniar, H. S., et al. (1996). A hierarchy of SSB protomers in Replication Protein A. *Genes Dev*, Vol. 10, No. 17 (pp. 2222-2233), 0890-9369 (Print) 0890-9369 (Linking)
- Plate, I., Hallwyl, S. C., Shi, I., et al. (2008). Interaction with RPA is necessary for Rad52 repair center formation and for its mediator activity. *J Biol Chem*, Vol. 283, No. 43 (pp. 29077-29085), 0021-9258 (Print) 0021-9258 (Linking)
- Pretto, D. I., Tsutakawa, S., Brosey, C. A., et al. (2010). Structural dynamics and single-stranded DNA binding activity of the three N-terminal domains of the large subunit of Replication Protein A from small angle X-ray scattering. *Biochemistry*, Vol. 49, No. 13 (pp. 2880-2889), 1520-4995 (Electronic) 0006-2960 (Linking)
- Pugh, R. A., Lin, Y., Eller, C., et al. (2008). *Ferroplasma acidarmanus* RPA2 facilitates efficient unwinding of forked DNA substrates by monomers of FacXPD helicase. *J Mol Biol*, Vol. 383, No. 5 (pp. 982-998), 1089-8638 (Electronic) 0022-2836 (Linking)
- Ralf, C., Hickson, I. D., & Wu, L. (2006). The Bloom's syndrome helicase can promote the regression of a model replication fork. *J Biol Chem*, Vol. 281, No. 32 (pp. 22839-22846), 0021-9258 (Print) 0021-9258 (Linking)
- Richard, D. J., Bolderson, E., Cubeddu, L., et al. (2008). Single-stranded DNA-binding protein hSSB1 is critical for genomic stability. *Nature*, Vol. 453, No. 7195 (pp. 677-681), 1476-4687 (Electronic) 0028-0836 (Linking)
- Richard, D. J., Bolderson, E., & Khanna, K. K. (2009). Multiple human single-stranded DNA binding proteins function in genome maintenance: structural, biochemical and functional analysis. *Crit Rev Biochem Mol Biol*, Vol. 44, No. 2-3 (pp. 98-116), 1549-7798 (Electronic) 1040-9238 (Linking)
- Richard, D. J., Cubeddu, L., Urquhart, A. J., et al. (2011). hSSB1 interacts directly with the MRN complex stimulating its recruitment to DNA double-strand breaks and its endo-nuclease activity. *Nucleic Acids Res*, 1362-4962 (Electronic) 0305-1048 (Linking)
- Richard, D. J., Savage, K., Bolderson, E., et al. (2011). hSSB1 rapidly binds at the sites of DNA double-strand breaks and is required for the efficient recruitment of the MRN complex. *Nucleic Acids Res*, Vol. 39, No. 5 (pp. 1692-1702), 1362-4962 (Electronic) 0305-1048 (Linking)

- Robbins, J. B., McKinney, M. C., Guzman, C. E., et al. (2005). The euryarchaeota, nature's medium for engineering of single-stranded DNA-binding proteins. *J Biol Chem*, Vol. 280, No. 15 (pp. 15325-15339), 0021-9258 (Print) 0021-9258 (Linking)
- Robbins, J. B., Murphy, M. C., White, B. A., et al. (2004). Functional analysis of multiple single-stranded DNA-binding proteins from *Methanosarcina acetivorans* and their effects on DNA synthesis by DNA polymerase β . *J Biol Chem*, Vol. 279, No. 8 (pp. 6315-6326), 0021-9258 (Print) 0021-9258 (Linking)
- Rolfmeier, M. L., & Haseltine, C. A. (2010). The single-stranded DNA binding protein of *Sulfolobus solfataricus* acts in the presynaptic step of homologous recombination. *J Mol Biol*, Vol. 397, No. 1 (pp. 31-45), 1089-8638 (Electronic) 0022-2836 (Linking)
- Saijo, M., Takedachi, A., & Tanaka, K. (2011). Nucleotide Excision Repair by Mutant Xeroderma Pigmentosum Group A (XPA) Proteins with Deficiency in Interaction with RPA. *J Biol Chem*, Vol. 286, No. 7 (pp. 5476-5483), 1083-351X (Electronic) 0021-9258 (Linking)
- Sakaguchi, K., Ishibashi, T., Uchiyama, Y., et al. (2009). The multi-Replication Protein A (RPA) system--a new perspective. *FEBS J*, Vol. 276, No. 4 (pp. 943-963), 1742-4658 (Electronic) 1742-464X (Linking)
- Santocanale, C., Neecke, H., Longhese, M. P., et al. (1995). Mutations in the gene encoding the 34 kDa subunit of yeast Replication Protein A cause defective S phase progression. *J Mol Biol*, Vol. 254, No. 4 (pp. 595-607), 0022-2836 (Print) 0022-2836 (Linking)
- Sharma, A., Nitharwal, R. G., Singh, B., et al. (2009). *Helicobacter pylori* single-stranded DNA binding protein--functional characterization and modulation of *H. pylori* DnaB helicase activity. *FEBS J*, Vol. 276, No. 2 (pp. 519-531), 1742-4658 (Electronic) 1742-464X (Linking)
- Sheng, D., Zhu, S., Wei, T., et al. (2008). The *in vitro* activity of a Rad55 homologue from *Sulfolobus tokodaii*, a candidate mediator in RadA-catalyzed homologous recombination. *Extremophiles*, Vol. 12, No. 1 (pp. 147-157), 1431-0651 (Print) 1431-0651 (Linking)
- Shereda, R. D., Bernstein, D. A., & Keck, J. L. (2007). A central role for SSB in *Escherichia coli* RecQ DNA helicase function. *J Biol Chem*, Vol. 282, No. 26 (pp. 19247-19258), 0021-9258 (Print) 0021-9258 (Linking)
- Shereda, R. D., Kozlov, A. G., Lohman, T. M., et al. (2008). SSB as an organizer/mobilizer of genome maintenance complexes. *Crit Rev Biochem Mol Biol*, Vol. 43, No. 5 (pp. 289-318), 1549-7798 (Electronic) 1040-9238 (Linking)
- Shultz, R. W., Tatineni, V. M., Hanley-Bowdoin, L., et al. (2007). Genome-wide analysis of the core DNA replication machinery in the higher plants *Arabidopsis* and rice. *Plant Physiol*, Vol. 144, No. 4 (pp. 1697-1714), 0032-0889 (Print) 0032-0889 (Linking)
- Soustelle, C., Vedel, M., Kolodner, R., et al. (2002). Replication Protein A is required for meiotic recombination in *Saccharomyces cerevisiae*. *Genetics*, Vol. 161, No. 2 (pp. 535-547), 0016-6731 (Print) 0016-6731 (Linking)
- Sowd, G., Wang, H., Pretto, D., et al. (2009). Replication Protein A stimulates the Werner syndrome protein branch migration activity. *J Biol Chem*, Vol. 284, No. 50 (pp. 34682-34691), 1083-351X (Electronic) 0021-9258 (Linking)
- Stephan, H., Concannon, C., Kremmer, E., et al. (2009). Ionizing radiation-dependent and independent phosphorylation of the 32-kDa subunit of Replication Protein A

- during mitosis. *Nucleic Acids Res*, Vol. 37, No. 18 (pp. 6028-6041), 1362-4962 (Electronic) 0305-1048 (Linking)
- Sugiman-Marangos, S., & Junop, M. S. (2010). The structure of DdrB from *Deinococcus*: a new fold for single-stranded DNA binding proteins. *Nucleic Acids Res*, Vol. 38, No. 10 (pp. 3432-3440), 1362-4962 (Electronic) 0305-1048 (Linking)
- Sugiyama, T., & Kantake, N. (2009). Dynamic regulatory interactions of rad51, rad52, and Replication Protein-A in recombination intermediates. *J Mol Biol*, Vol. 390, No. 1 (pp. 45-55), 1089-8638 (Electronic) 0022-2836 (Linking)
- Suhasini, A. N., Sommers, J. A., Mason, A. C., et al. (2009). FANCD1 helicase uniquely senses oxidative base damage in either strand of duplex DNA and is stimulated by Replication Protein A to unwind the damaged DNA substrate in a strand-specific manner. *J Biol Chem*, Vol. 284, No. 27 (pp. 18458-18470), 1083-351X (Electronic) 0021-9258 (Linking)
- Sun, J., Yu, E. Y., Yang, Y., et al. (2009). Stn1-Ten1 is an Rpa2-Rpa3-like complex at telomeres. *Genes Dev*, Vol. 23, No. 24 (pp. 2900-2914), 1549-5477 (Electronic) 0890-9369 (Linking)
- Takashi, Y., Kobayashi, Y., Tanaka, K., et al. (2009). *Arabidopsis* Replication Protein A 70a is required for DNA damage response and telomere length homeostasis. *Plant Cell Physiol*, Vol. 50, No. 11 (pp. 1965-1976), 1471-9053 (Electronic) 0032-0781 (Linking)
- Tanaka, M., Earl, A. M., Howell, H. A., et al. (2004). Analysis of *Deinococcus radiodurans*'s transcriptional response to ionizing radiation and desiccation reveals novel proteins that contribute to extreme radioresistance. *Genetics*, Vol. 168, No. 1 (pp. 21-3), 0016-6731 (Print) 0016-6731 (Linking)
- Teng, Y., Longhese, M., McDonough, G., et al. (1998). Mutants with changes in different domains of yeast Replication Protein A exhibit differences in repairing the control region, the transcribed strand and the non-transcribed strand of the *Saccharomyces cerevisiae* MFA2 gene. *J Mol Biol*, Vol. 280, No. 3 (pp. 355-363), 0022-2836 (Print) 0022-2836 (Linking)
- Theobald, D. L., Mitton-Fry, R. M., & Wuttke, D. S. (2003). Nucleic acid recognition by OB-fold proteins. *Annu Rev Biophys Biomol Struct*, Vol. 32, (pp. 115-133), 1056-8700 (Print) 1056-8700 (Linking)
- Theriot, C. A., Hegde, M. L., Hazra, T. K., et al. (2010). RPA physically interacts with the human DNA glycosylase NEIL1 to regulate excision of oxidative DNA base damage in primer-template structures. *DNA Repair (Amst)*, Vol. 9, No. 6 (pp. 643-652), 1568-7856 (Electronic) 1568-7856 (Linking)
- Ujaoney, A. K., Potnis, A. A., Kane, P., et al. (2010). Radiation desiccation response motif-like sequences are involved in transcriptional activation of the *Deinococcus* *ssb* gene by ionizing radiation but not by desiccation. *J Bacteriol*, Vol. 192, No. 21 (pp. 5637-5644), 1098-5530 (Electronic) 0021-9193 (Linking)
- Umezū, K., Sugawara, N., Chen, C., et al. (1998). Genetic analysis of yeast RPA1 reveals its multiple functions in DNA metabolism. *Genetics*, Vol. 148, No. 3 (pp. 989-1005), 0016-6731 (Print) 0016-6731 (Linking)
- Vassin, V. M., Anantha, R. W., Sokolova, E., et al. (2009). Human RPA phosphorylation by ATR stimulates DNA synthesis and prevents ssDNA accumulation during DNA-replication stress. *J Cell Sci*, Vol. 122, No. Pt 22 (pp. 4070-4080), 1477-9137 (Electronic) 0021-9533 (Linking)

- Wadsworth, R. I., & White, M. F. (2001). Identification and properties of the crenarchaeal single-stranded DNA binding protein from *Sulfolobus solfataricus*. *Nucleic Acids Res*, Vol. 29, No. 4 (pp. 914-920), 1362-4962 (Electronic) 0305-1048 (Linking)
- Wang, Y., Putnam, C. D., Kane, M. F., et al. (2005). Mutation in Rpa1 results in defective DNA double-strand break repair, chromosomal instability and cancer in mice. *Nat Genet*, Vol. 37, No. 7 (pp. 750-755), 1061-4036 (Print) 1061-4036 (Linking)
- Williams, G. J., Lees-Miller, S. P., & Tainer, J. A. (2010). Mre11-Rad50-Nbs1 conformations and the control of sensing, signaling, and effector responses at DNA double-strand breaks. *DNA Repair (Amst)*, Vol. 9, No. 12 (pp. 1299-1306), 1568-7856 (Electronic) 1568-7856 (Linking)
- Witte, G., Urbanke, C., & Curth, U. (2003). DNA polymerase III chi subunit ties single-stranded DNA binding protein to the bacterial replication machinery. *Nucleic Acids Res*, Vol. 31, No. 15 (pp. 4434-4440), 1362-4962 (Electronic) 0305-1048 (Linking)
- Wold, M. S. (1997). Replication Protein A: a heterotrimeric, single-stranded DNA-binding protein required for eukaryotic DNA metabolism. *Annu Rev Biochem*, Vol. 66, (pp. 61-92), 0066-4154 (Print) 0066-4154 (Linking)
- Woodman, I. L., Brammer, K., & Bolt, E. L. (2010). Physical interaction between archaeal DNA repair helicase Hel308 and Replication Protein A (RPA). *DNA Repair (Amst)*, 1568-7856 (Electronic) 1568-7856 (Linking)
- Xu, G., Lu, H., Wang, L., et al. (2010). DdrB stimulates single-stranded DNA annealing and facilitates RecA-independent DNA repair in *Deinococcus radiodurans*. *DNA Repair (Amst)*, Vol. 9, No. 7 (pp. 805-812), 1568-7856 (Electronic) 1568-7856 (Linking)
- Xu, X., Vaithiyalingam, S., Glick, G. G., et al. (2008). The basic cleft of RPA70N binds multiple checkpoint proteins, including RAD9, to regulate ATR signaling. *Mol Cell Biol*, Vol. 28, No. 24 (pp. 7345-7353), 1098-5549 (Electronic) 0270-7306 (Linking)
- Yang, J., Yu, Y., Hamrick, H. E., et al. (2003). ATM, ATR and DNA-PK: initiators of the cellular genotoxic stress responses. *Carcinogenesis*, Vol. 24, No. 10 (pp. 1571-1580), 0143-3334 (Print) 0143-3334 (Linking)
- Yuan, J., Ghosal, G., & Chen, J. (2009). The annealing helicase HARP protects stalled replication forks. *Genes Dev*, Vol. 23, No. 20 (pp. 2394-2399), 1549-5477 (Electronic) 0890-9369 (Linking)
- Yusufzai, T., Kong, X., Yokomori, K., et al. (2009). The annealing helicase HARP is recruited to DNA repair sites via an interaction with RPA. *Genes Dev*, Vol. 23, No. 20 (pp. 2400-2404), 1549-5477 (Electronic) 0890-9369 (Linking)
- Yuzhakov, A., Kelman, Z., Hurwitz, J., et al. (1999). Multiple competition reactions for RPA order the assembly of the DNA polymerase delta holoenzyme. *EMBO J*, Vol. 18, No. 21 (pp. 6189-6199), 0261-4189 (Print) 0261-4189 (Linking)
- Yuzhakov, A., Kelman, Z., & O'Donnell, M. (1999). Trading places on DNA--a three-point switch underlies primer handoff from primase to the replicative DNA polymerase. *Cell*, Vol. 96, No. 1 (pp. 153-163), 0092-8674 (Print) 0092-8674 (Linking)
- Zernik-Kobak, M., Vasunia, K., Connelly, M., et al. (1997). Sites of UV-induced phosphorylation of the p34 subunit of Replication Protein A from HeLa cells. *J Biol Chem*, Vol. 272, No. 38 (pp. 23896-23904), 0021-9258 (Print) 0021-9258 (Linking)
- Zou, L., & Elledge, S. J. (2003). Sensing DNA damage through ATRIP recognition of RPA-ssDNA complexes. *Science*, Vol. 300, No. 5625 (pp. 1542-1548), 1095-9203 (Electronic) 0036-8075 (Linking)

Zou, L., Liu, D., & Elledge, S. J. (2003). Replication Protein A-mediated recruitment and activation of Rad17 complexes. *Proc Natl Acad Sci U S A*, Vol. 100, No. 24 (pp. 13827-13832), 0027-8424 (Print) 0027-8424 (Linking)

IntechOpen

IntechOpen

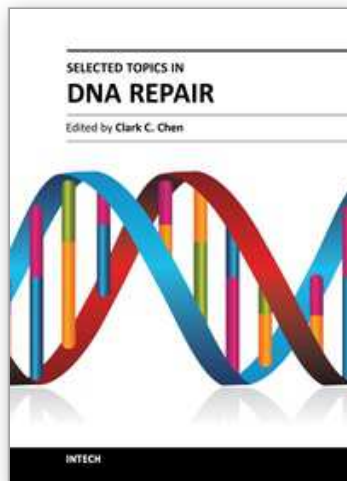

Selected Topics in DNA Repair

Edited by Prof. Clark Chen

ISBN 978-953-307-606-5

Hard cover, 572 pages

Publisher InTech

Published online 26, October, 2011

Published in print edition October, 2011

This book is intended for students and scientists working in the field of DNA repair, focusing on a number of topics ranging from DNA damaging agents and mechanistic insights to methods in DNA repair and insights into therapeutic strategies. These topics demonstrate how scientific ideas are developed, tested, dialogued, and matured as it is meant to discuss key concepts in DNA repair. The book should serve as a supplementary text in courses and seminars as well as a general reference for biologists with an interest in DNA repair.

How to reference

In order to correctly reference this scholarly work, feel free to copy and paste the following:

Patrick E. Gygli, J. Scott Lockhart and Linda C. DeVeaux (2011). Role of RPA Proteins in Radiation Repair and Recovery, Selected Topics in DNA Repair, Prof. Clark Chen (Ed.), ISBN: 978-953-307-606-5, InTech, Available from: <http://www.intechopen.com/books/selected-topics-in-dna-repair/role-of-rpa-proteins-in-radiation-repair-and-recovery>

INTECH
open science | open minds

InTech Europe

University Campus STeP Ri
Slavka Krautzeka 83/A
51000 Rijeka, Croatia
Phone: +385 (51) 770 447
Fax: +385 (51) 686 166
www.intechopen.com

InTech China

Unit 405, Office Block, Hotel Equatorial Shanghai
No.65, Yan An Road (West), Shanghai, 200040, China
中国上海市延安西路65号上海国际贵都大饭店办公楼405单元
Phone: +86-21-62489820
Fax: +86-21-62489821

© 2011 The Author(s). Licensee IntechOpen. This is an open access article distributed under the terms of the [Creative Commons Attribution 3.0 License](#), which permits unrestricted use, distribution, and reproduction in any medium, provided the original work is properly cited.

IntechOpen

IntechOpen