

# We are IntechOpen, the world's leading publisher of Open Access books Built by scientists, for scientists

**4,800**

Open access books available

**122,000**

International authors and editors

**135M**

Downloads

Our authors are among the

**154**

Countries delivered to

**TOP 1%**

most cited scientists

**12.2%**

Contributors from top 500 universities



**WEB OF SCIENCE™**

Selection of our books indexed in the Book Citation Index  
in Web of Science™ Core Collection (BKCI)

Interested in publishing with us?  
Contact [book.department@intechopen.com](mailto:book.department@intechopen.com)

Numbers displayed above are based on latest data collected.

For more information visit [www.intechopen.com](http://www.intechopen.com)



# Modeling, Simulation and Control of a Power Assist Robot for Manipulating Objects Based on Operator's Weight Perception

S. M. Mizanoor Rahman<sup>1</sup>, Ryojun Ikeura<sup>2</sup> and Haoyong Yu<sup>1</sup>

<sup>1</sup>National University of Singapore

<sup>2</sup>Mie University

<sup>1</sup>Singapore

<sup>2</sup>Japan

## 1. Introduction

### 1.1 Power assist robot and its current applications

Power assist robot is a human-robot cooperation that extends human's abilities and skills in performing works (Kazerooni, 1993). Breakthrough in power assist robots was conceived in early 1960s with "Man-amplifier" and "Hardiman" (Kazerooni, 1993), but the progress of research on this significant field is not satisfactory yet. It is found through literature that power assist systems are currently being developed mainly for sick, physically disabled and old people as healthcare and rehabilitation supports (Kong *et al.*, 2009; Seki, Ishihara and Tadakuma, 2009). Few power assist systems have also been developed for other applications such as for lifting baby carriage (Kawashima, 2009), physical support for workers performing agricultural jobs (Tanaka *et al.*, 2008), hydraulic assist for automobiles (Liu *et al.*, 2009), skill-assist for manufacturing (Lee, Hara and Yamada, 2008), assisted slide doors for automobiles (Osamura *et al.*, 2008), assist-control for bicycle (Kosuge, Yabushita and Hirata, 2004), assist for sports training (Ding, Ueda and Ogasawara, 2008), etc.

### 1.2 Manipulating heavy objects in industries with power assist robots

We think that handling heavy objects, which is common and necessary in many industries, is another potential field of application of power assist robots. It is always necessary to move heavy objects in industries such as manufacturing and assembly, mining, construction, logistics and transport, disaster and rescue operations, forestry, agriculture etc. Manual manipulation of heavy objects is very cumbersome and it causes work-related disabilities and disorders such as back pain to humans. On the contrary, handling objects by autonomous systems may not provide required flexibility in many cases. Hence, it is thought that the uses of suitable human-robot cooperation systems such as power assist systems may be appropriate for handling heavy objects in industries. However, suitable power assist systems are not found in industries for this purpose because their design has not got much attention yet.

### 1.3 Weight illusion for power assist robots

A power assist robot reduces the perceived heaviness of an object manipulated with it (Kazerooni, 1993), as illustrated in Fig.1. Hence, load force (manipulative force tangential to

grip surfaces) required to manipulate an object with a power assist robot should be lower than that required to manipulate the object manually. But, the limitations with the conventional power assist systems are that the operator cannot perceive the heaviness of the object correctly before manipulating it with the system and eventually applies excessive load force. The excessive load force results in sudden increase in acceleration, fearfulness of the operator, lack of maneuverability and stability, fatal accident etc. Fig.2 further explains the interaction processes and phenomena between a power assist robot and its operator for object manipulation. A few power assist systems are available for carrying objects (Doi *et al.*, 2007; Hara, 2007; Lee *et al.*, 2000; Miyoshi and Terashima, 2004). But, their safety, maneuverability, operability, naturalness, stability and other interactions with users are not so satisfactory because their controls do not consider human characteristics especially weight illusion and load force features.

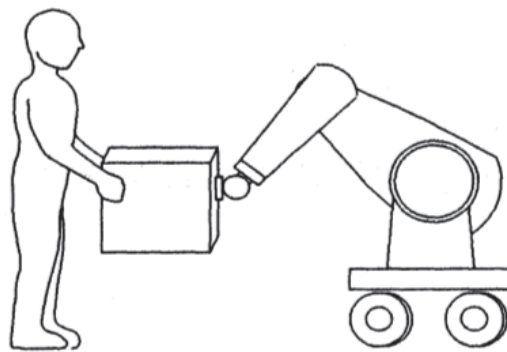

Fig. 1. A human manipulates (lifts) an object with a power assist robot and feels a scaled-down portion of the weight.

#### 1.4 Distinctions between unimanual and bimanual manipulation

It is noticed in practices in industries that workers need to employ one or two hands to manipulate objects and they decide this on the basis of object's physical features such as shape, size, mass etc. as well as of task requirements (Bracewell *et al.*, 2003; Giachritsis and Wing, 2008; Lum, Reinkensmeyer and Lehman, 1993; Rahman *et al.*, 2009a). We assume that weight perception, load force and object motions for unimanual manipulation may be different from that for bimanual manipulation, and these differences may affect modeling the control. Hence, it seems to be necessary to study unimanual weight perception, load force and motion features and to compare these to that for bimanual manipulation, and to reflect the differences in modeling the power-assist control. We studied distinctions between unimanual and bimanual manipulation in our previous works though it is still necessary to deeply look into their differences to make the control more appropriate (Rahman *et al.*, 2009a , 2011a).

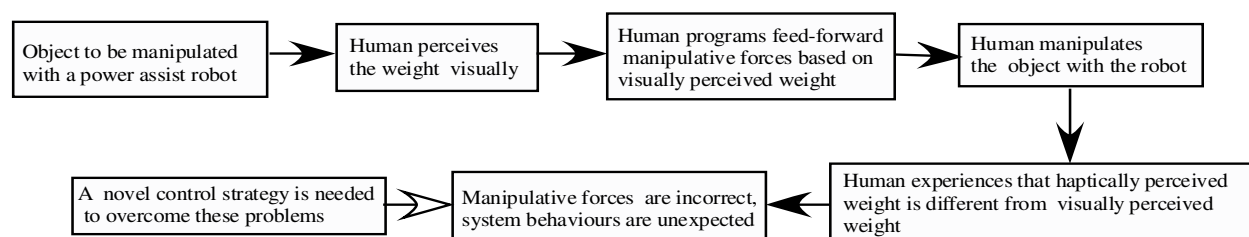

Fig. 2. Interaction processes and phenomena between robot and human when manipulating an object with a power assist robot.

### 1.5 Lifting, lowering and horizontal manipulation

In industries, workers need to transfer objects in different directions such as vertical lifting (lift objects from lower to higher position), vertical lowering (lower objects from higher to lower position), horizontal manipulation etc. in order to satisfy task requirements. We assume that maneuverability, heaviness perception, load force and motions for manipulating objects among these directions may be different from each other and these differences may affect the control and the system performances. Hence, it seems to be necessary to study object manipulation in all of these directions, compare them to each other, and to reflect the differences in the control (Rahman et al., 2010a, 2011a). However, such study has also not been carried out yet in detailed. We studied lifting objects in vertical direction in our previous works (Rahman *et al.*, 2009a, 2010c, 2011a), but manipulating objects in horizontal direction is still unaddressed though horizontal manipulation of objects is very common in practical fields. A few power-assist robotic systems consider manipulating objects in horizontal direction. But, they are not targetted to industrial applications and they have limitations in performances as they do not consider human characteristics in their control modeling (Hara, 2007).

### 1.6 The chapter summary

This chapter presents a power assist robot system developed for manipulating objects in horizontal direction in cooperation with human. Weight perception was included in robot dynamics and control. The robot was simulated for manipulating objects in horizontal direction. Optimum maneuverability conditions for horizontal manipulation of objects were determined and were compared to that for vertical lifting of objects. Psychophysical relationships between actual and perceived weights were determined, and load forces and motion features were analyzed for horizontal manipulation of objects. Then, a novel control scheme was implemented to reduce the excessive load forces and accelerations, and thus to improve the system performances. The novel control reduced the excessive load forces and accelerations for horizontal manipulation of objects, and thus improved the system performances in terms of maneuverability, safety, operability etc. We compared our results to that of related works. Finally, we proposed to use the findings to develop human-friendly power assist robots for manipulating heavy objects in various industries.

This chapter provides information to the readers about the power assist robot system- its innovative mechanical design, dynamics, modeling, control, simulation, application etc. Thus this chapter introduces a new area of applications of power assist robot systems and also introduces innovations in its dynamics, modeling, control etc. On the other hand, the readers will get a detailed explanation and practical example of how to use Matlab/Simulink to develop and simulate a dynamic system (e.g., a power assist robot system). The readers will also receive a practical example of how to measure and evaluate human factors subjectively for a technical domain (e.g., a power assist robot system). As a whole, this chapter will enrich the readers with novel concepts in robotics and control technology, Matlab/Simulink application, human factors/ergonomics, psychology and psychophysics, biomimetics, weight perception, human-robot/machine interaction, user interface design, haptics, cognitive science, biomechanics etc. The contents of this chapter were also compared to related works available in published literatures. Thus, the readers will get a collection of all possible works related and similar to the contents of this chapter.

## 2. The experimental robotic system: Configuration, dynamics and control

### 2.1 Configuration

We developed a 1-DOF (horizontal translational motion) power assist robot system using a ball screw assembly actuated by an AC servomotor (Type: SGML-01BF12, made by Yaskawa, Japan). The ball screw assembly and the servomotor were coaxially fixed on a metal board and the board was horizontally placed on a table. Three rectangular boxes were made by bending aluminum sheets (thickness: 0.5 mm). These boxes were horizontally manipulated with the power assist robot system and were called the power-assisted objects (PAOs). A PAO (box), at a time, could be tied to the ball nut (linear slider) of the ball screw assembly through a force sensor (foil strain gauge type, NEC Ltd.) and be manipulated by a human subject. The dimensions (length x width x height) of the boxes were 16 x 6 x 5cm, 12 x 6 x 5cm and 8.6 x 6 x 5cm for the large, medium and small size respectively. The bottom, left and right sides of each PAO were open. The complete experimental setup of the power assist robot system is depicted in Fig.3. The servodrive receives a command signal (voltage signal) from the controller through a D/A converter, amplifies the signal, and transmits electric current to the servomotor in order to produce motion proportional to the commanded signal. The position sensor (encoder with counter) reports (pulse signal) object's actual displacement back to the servodrive. The servodrive then compares the actual displacement to the desired displacement. It then alters the commanded signal to the motor so as to correct for any error in the displacement. Human force is sensed by the force sensor attached between the ball nut and the object. The force is sensed as voltage signal, amplified by the amplifier and then sent to the control system via an A/D converter. Human force gives only motion (acceleration) to the object.

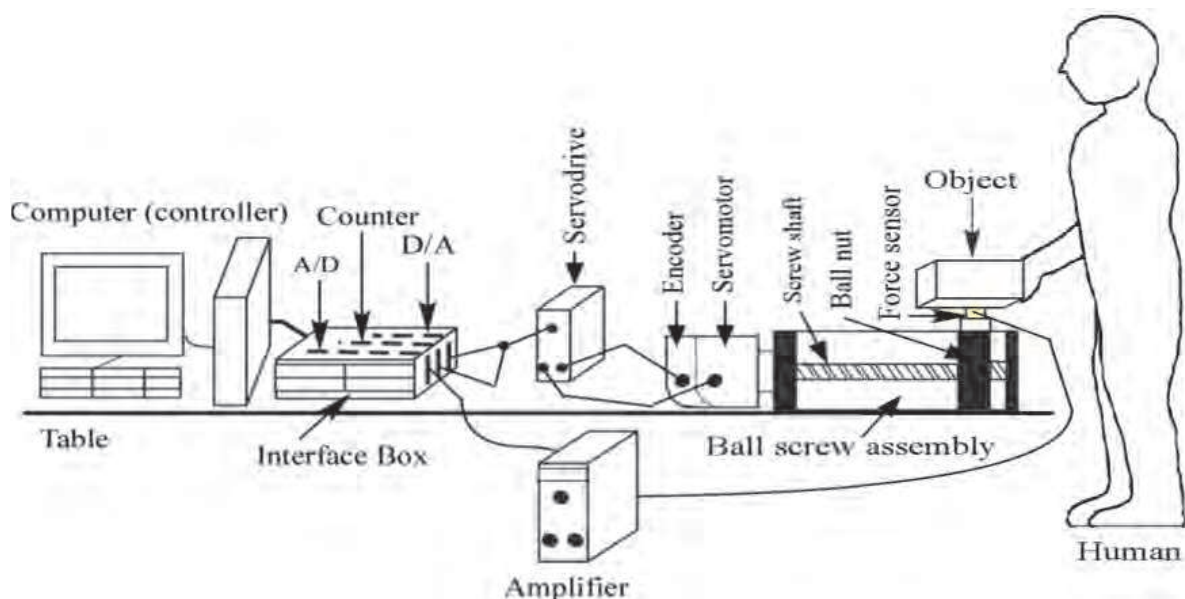

Fig. 3. Experimental setup of the 1-DOF power assist robot system.

### 2.2 Dynamics

According to Fig.4, the dynamics of the PAO when it is manipulated horizontally by a subject with the power assist robot system is described by Eq.(1), where  $F_o=mg$ . If we include our hypothesis in the dynamics, then Eq.(1) changes to Eq.(2). Both  $m_1$  and  $m_2$  stand for

mass, but  $m_1$  forms inertial force and  $m_2$  forms gravitational force,  $m_1 \neq m_2 \neq m, m_1 \ll m, m_2 \ll m, |m_1 \ddot{x}_d| \neq |m_2 g|$ . A difference between  $m_1$  and  $m_2$  arises due to the difference between human's perception and reality regarding the heaviness of the object manipulated with the power assist system (Kazerooni, 1993).

$$m\ddot{x}_d = f_h + F_0 \tag{1}$$

$$m_1\ddot{x}_d = f_h + m_2g. \tag{2}$$

Where,

$m =$  Actual mass of the object

$x_d =$  Desired displacement of the object

$g =$  Acceleration of gravity

$f_h =$  Load force applied by the subject

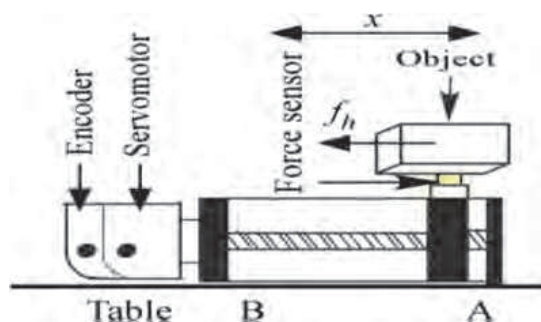

Fig. 4. Dynamics of 1-DOF power assist system for horizontal manipulation of objects. The PAO tied to the force sensor is moved by the subject from 'A' to 'B' position.

### 2.3 Control

We derived Eqs. (3)- (5) from Eq. (2). We then diagrammed the power-assist control based on Eqs.(3)-(5), which is shown in Fig.5. Eq. (3) gives the desired acceleration. Then, Eq. (3) is integrated and the integration gives the desired velocity ( $\dot{x}_d$ ). Then, the velocity is integrated and the integration gives the desired displacement ( $x_d$ ).

$$\ddot{x}_d = \frac{1}{m_1} (f_h + m_2g) \tag{3}$$

$$\dot{x}_d = \int \ddot{x}_d dt \tag{4}$$

$$x_d = \int \dot{x}_d dt \tag{5}$$

$$\dot{x}_c = \dot{x}_d + G(x_d - x) \tag{6}$$

If the system is simulated using Matlab/Simulink in the velocity control mode of the servomotor, the commanded velocity ( $\dot{x}_c$ ) to the servomotor is calculated by Eq. (6). The commanded velocity is provided to the servomotor through the D/A converter. During simulation, the servodrive determines the error displacement signal by comparing the actual displacement to the desired displacement and generates the control.

The following three types of control methods are usually used in power assist systems:-

1. Position based impedance control
2. Torque/force based impedance control
3. Force control

Position based impedance control and torque/force based impedance control produce good results. Results may be different for force control for reducing excessive force. Our control as introduced above is limited to position based impedance control. We used position based impedance control for the following reasons (advantages):

1. Position based impedance control automatically compensates the effects of friction, inertia, viscosity etc. In contrast, these effects are needed to consider for force control, however, it is very difficult to model and calculate the friction force for the force control. Dynamic effects, nonlinear forces etc. affect system performances for force control for multi-degree of freedom system.
2. Ball-screw gear ratio is high and actuator force is less for position control. However, the opposite is true for the force control.
3. It is easy to realize the real system for the position control for high gear ratio. However, the opposite is true for the force control.

However, there are some disadvantages of position control as the following:

1. Instability is high in position control. If we see Fig.5 we find that a feedback loop is created between  $x$  and  $f_h$  when human touches/grasps the object for manipulation. This feedback effect causes instability. In contrast, force control has less or no stability problem.
2. Motor system delay affects the stability more intensively for position control.
3. Value of  $G$  and velocity control also can compensate the effects of friction, inertia, viscosity etc., but the effects are not compensated completely, which may affect human's weight perception.

If the difference between  $m$  and  $m_1$  is very large i.e., if  $(m-m_1)$  is very big, the position control imposes very high load to the servomotor that results in instability, which is not so intensive for force control. Force control is better in some areas, but position control is better in some other areas. However, position control is to be effective for this chapter. Force control may be considered in near future.

The control shown in Fig.5 is not so complicated. However, there is novelty in this control that human's perception is included in this control. Again, another novel control strategy is also derived from this control that includes human features. This control can be recognized as an exemplary and novel control for human interactive robot control.

### **3. Experiment 1: Analyzing maneuverability, heaviness perception, force and motion features**

#### **3.1 Subjects**

Ten mechanical engineering male students aged between 23 and 30 years were nominated to voluntarily participate in the experiment. The subjects were believed to be physically and mentally healthy. The subjects did not have any prior knowledge of the hypothesis being tested. Instructions regarding the experiment were given to them, but no formal training was arranged.

#### **3.2 Evaluation criteria for power assist robot systems**

Power assist can be defined as augmenting the ability or adjusting to the situation when human operates and works. In particular, in case of supporting for elderly and disabled people, the purpose of power assist is improvement of QOL (Quality of Life), that is, support for daily life. It has two meanings. One is support for self-help and the other is support for caring. The former is to support self-sustained daily life, and the latter is to decrease burden of caregiver.

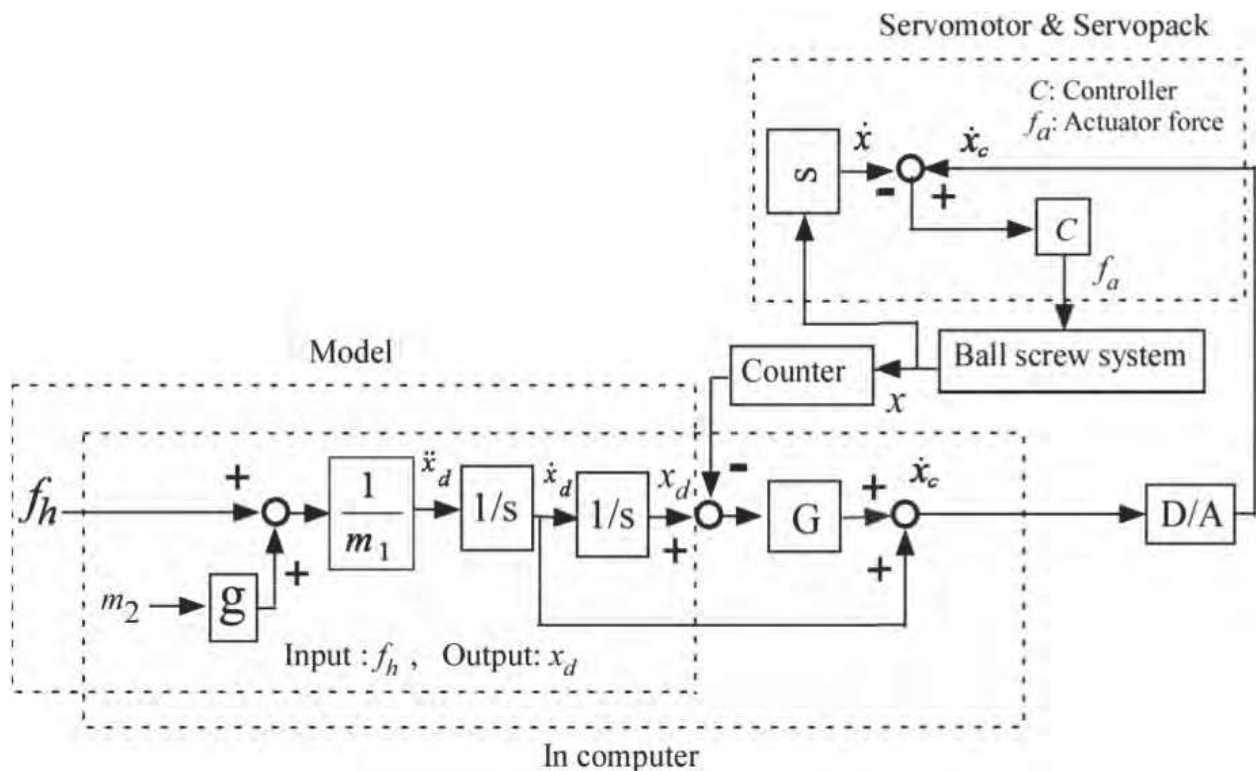

Fig. 5. Block diagram of the power-assist control, where  $G$  denotes feedback gain,  $D/A$  indicates  $D/A$  converter and  $x$  denotes actual displacement. Feedback position control is used with the servomotor in velocity control mode.

There are two requirements for power assist systems. The first requirement is amplification of human force, assistance of human motion etc. This is the realization of power assist itself, and there may have problems such as its realization method and stability of human-robot system. The second is safety, sense of security, operability, ease of use etc. This requirement does not appear as specific issue comparing to the first requirement, and it is difficult to be taken into account. However, in order to make power assist systems useful, the second requirement is more important than the first requirement. In case of lifting objects, we think that the main requirements for the power assist systems are maneuverability, safety and stability. Again, these requirements are interrelated where maneuverability plays the pivotal role.

Some basic requirements of a power assist system regarding its maneuverability have been mentioned by Seki, Iso and Hori (2002). However, we thought that only the light (less force required), natural and safe system can provide consistent feelings of ease of use and comfort though too light system may be unsafe, uneasy and uncomfortable. Hence, we considered operator's ease of use and comfort as the evaluation criteria for maneuverability of the power assist robot system.

### 3.3 Objectives

Objectives of experiment 1 were to (i) determine conditions for optimum maneuverability, (ii) determine psychophysical relationships between actual and perceived weights, (iii) analyze load force and determine excess in load force, (iv) analyze object's motions-displacement, velocity and acceleration etc. for manipulating objects with the power assist robot system in horizontal direction.



### 3.4 Design of the experiment

Independent variables were  $m_1$  and  $m_2$  values, and visual object sizes. Dependent variables were maneuverability, perceived weight, load force, and object's motions (displacement, velocity and acceleration).

### 3.5 Experiment procedures

The system shown in Fig.5 was simulated using Matlab/Simulink (solver: ode4, Runge-Kutta; type: fixed-step; fundamental sample time: 0.001s) for twelve  $m_1$  and  $m_2$  sets (Table 1) separately. The ranges of values of  $m_1$  and  $m_2$  were nominated based on our experience. The program for simulation is shown in Fig.6. We set the parameters of three custom-derived blocks such as counter, D/A converter and A/D converter before the simulation started. Fig. 7 shows what the parameters were and how they were set.

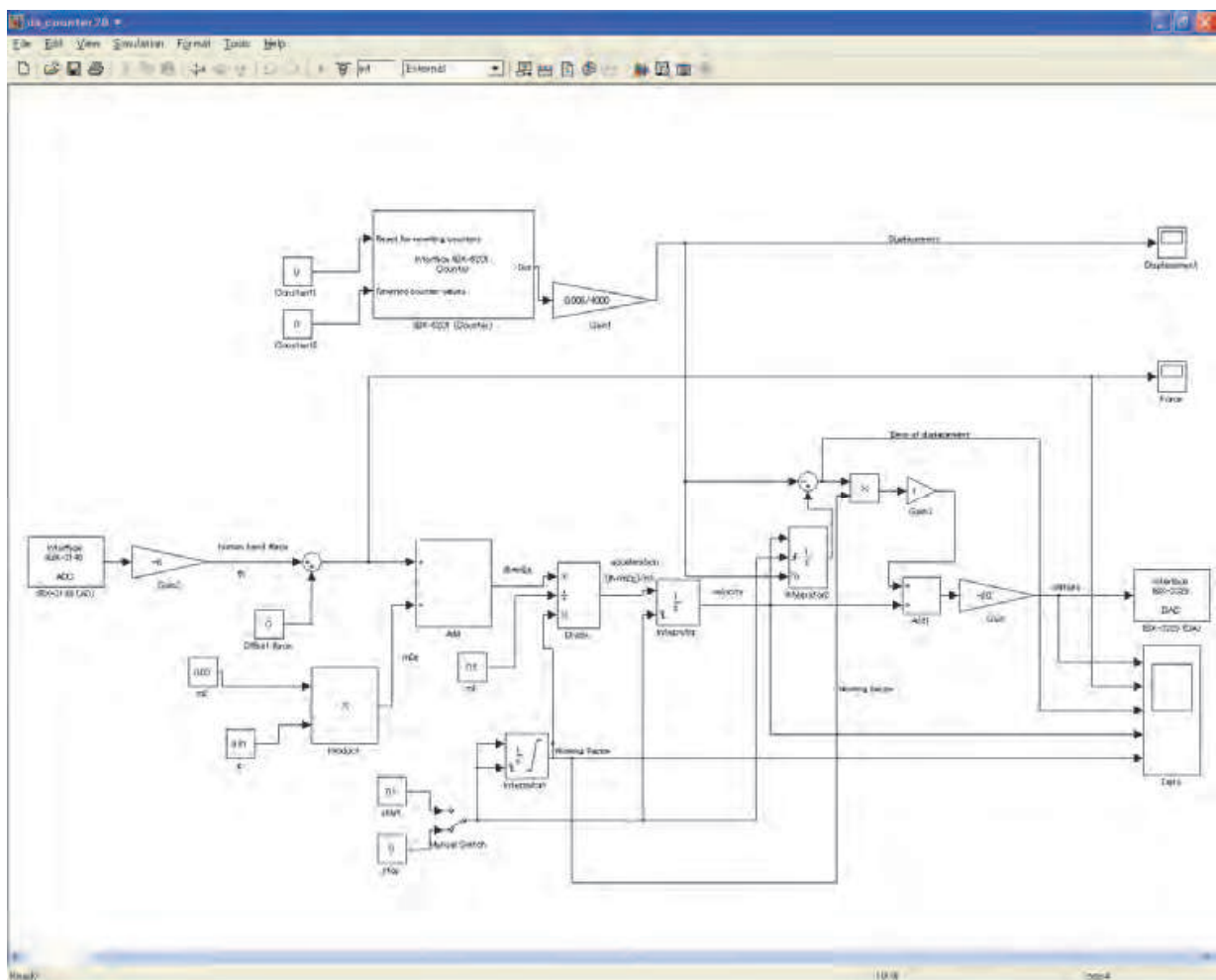

Fig. 6. The program for the simulation

The subject manipulated (from 'A' to 'B' as in Fig.4, distance between 'A' and 'B' was about 0.12 m) each size object with the robot system once for each  $m_1$  and  $m_2$  set separately. The task required the subject to manipulate the object approximately 0.1m, maintain the object for 1-2 seconds and then release the object. For each trial (for each  $m_1$  and  $m_2$  set for each size object), the subject subjectively evaluated the system for maneuverability as any one of the following alternatives:-

1. Very Easy & Comfortable (score: +2)
2. Easy & Comfortable (score: +1)
3. Borderline (score: 0)
4. Uneasy & Uncomfortable (score: -1)
5. Very Uneasy & Uncomfortable (score: -2)

All subjects evaluated the system for maneuverability as above for small, medium, large object independently for each  $m_1$  and  $m_2$  set. Load force and motions data were recorded separately for each trial.

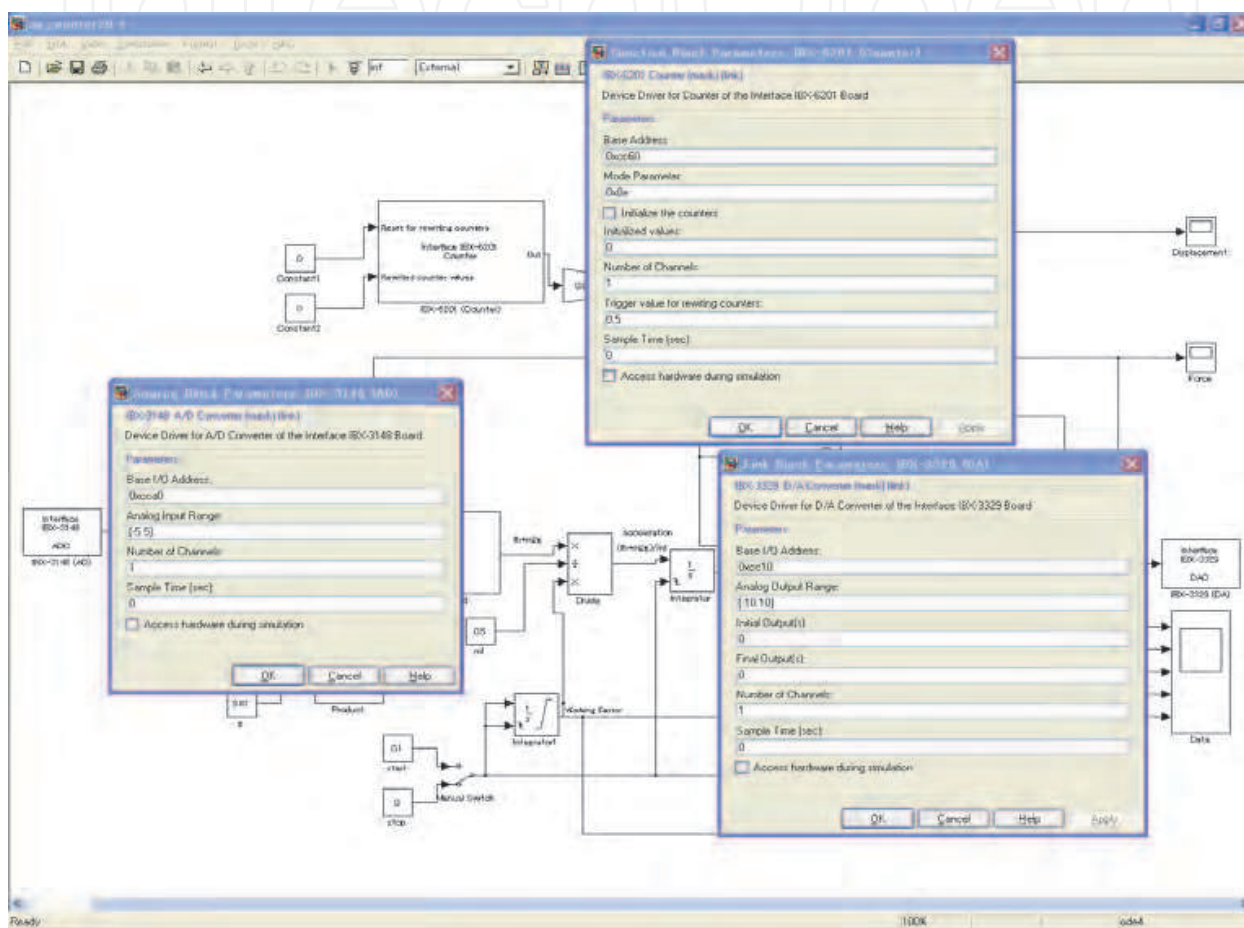

Fig. 7. Setting appropriate parameters for the custom-derived blocks.

Each subject after each trial also manually manipulated a reference-weight object horizontally on a table using right hand alone for reference weights. Weight of the reference-weight object was sequentially changed in a descending order starting from 0.1 kg and ending at 0.01 kg maintaining an equal difference of 0.01 kg i.e., 0.1, 0.09,...0.02, 0.01kg. The subject thus compared the perceived weight of the PAO to that of the reference-weight object and estimated the magnitude of the perceived weight following the psychophysical method 'constant stimuli'. Appearance of PAO and reference-weight object were the same.

$m_1$ (kg)	2.0	1.5	1.0	0.5
$m_2$ (kg)	0.09	0.06	0.03	

Table 1. Values of variables for the simulation

### 3.6 Experiment results

#### 3.6.1 Optimum maneuverability

Mean evaluation scores of the system regarding its maneuverability for 12  $m_1$  and  $m_2$  sets for each size object were determined separately. Table 2 shows the mean evaluation scores for the medium size object. Similar scores were also determined for large and small size objects. The results reveal that maneuverability is not affected by visual size of object. The reason may be that human evaluates maneuverability using haptic senses where visual size cue has no influence. However, haptic cues might influence the maneuverability.

The table shows that ten  $m_1$  and  $m_2$  sets got positive scores whereas the remaining two sets got negative scores. Results show that  $m_1=0.5\text{kg}$ ,  $m_2=0.03\text{kg}$  and  $m_1=1\text{kg}$ ,  $m_2=0.03\text{kg}$  got the highest scores. Hence, optimum maneuverability may be achieved at any one of these two conditions. We think that a unique and single condition for optimum maneuverability could be determined if more values of  $m_1$  and  $m_2$  were used for the simulation. The subjects felt very easy and comfortable to manipulate objects with the power assist system only when  $m_1=0.5\text{kg}$ ,  $m_2=0.03\text{kg}$  and  $m_1=1\text{kg}$ ,  $m_2=0.03\text{kg}$ . This is why these two sets were declared as the optimum conditions for maneuverability. Here, optimality was decided based on human's feelings following heuristics.

These findings indicate the significance of our hypothesis that we would not be able to sort out the positive sets (satisfactory level of maneuverability) of values of  $m_1$  and  $m_2$  from the negative sets (unsatisfactory level of maneuverability) of values of  $m_1$  and  $m_2$  for different sizes of objects unless we thought  $m_1 \neq m_2 \neq m$ ,  $m_1 \ll m$ ,  $m_2 \ll m$ ,  $m_1 \ddot{x}_d \neq m_2 g$ .

We see that the optimum/best sets are also the sets of the smallest values of  $m_1$  and  $m_2$  in this experiment. If much smaller values of  $m_1$  and  $m_2$  are chosen randomly, the perceived heaviness may further reduce, but it needs to clarify whether or not this is suitable for human psychology. Again, in zero-gravity or weightless condition when  $m_2=0$ , the object is supposed to be too light as it was studied by Marc and Martin (2002) in actual environment and by Dominjon *et al.* (2005) in virtual environment. It was found that the zero-gravity is not feasible because the human loses some haptic information at zero-gravity that hampers human's weight perception ability (Rahman *et al.*, 2009b). It is still not known whether the optimum sets are optimum only for the particular conditions of this experiment or they will persist as the optimum for all conditions in practical uses in industries.

$m_1$	$m_2$	Mean maneuverability score
1	0.06	+0.83(0.41)
2	0.06	+0.33(1.21)
0.5	0.03	+2.0 (0)
1	0.03	+2.0 (0)
1.5	0.03	+1.5 (0.55)
2	0.09	-0.17(0.98)
0.5	0.06	+1.0 (0)
1.5	0.09	-0.17(0.98)
0.5	0.09	+0.17(0.75)
1	0.09	+1.0 (0.63)
1.5	0.06	+0.67(0.52)
2	0.03	+1.17(0.41)

Table 2. Mean maneuverability scores with standard deviations (in parentheses) for the medium size object

### 3.6.2 Relationship between actual and perceived weight

We determined the mean perceived weight for each size object separately for  $m_1=0.5\text{kg}$ ,  $m_2=0.03\text{kg}$  (condition 1) and  $m_1=1\text{kg}$ ,  $m_2=0.03\text{ kg}$  (condition 2) as shown in Fig.8. We assumed  $m_2$  as the actual weight of the power-assisted object. It means that the actual weight was 0.03kg or 0.2943 N for each size object for the two  $m_1$  and  $m_2$  sets. We compared the perceived weights of Fig.8 to the actual weight (0.2943 N) for each size object for  $m_1=0.5\text{kg}$ ,  $m_2=0.03\text{kg}$  and  $m_1=1\text{kg}$ ,  $m_2=0.03\text{ kg}$ . The figure shows and we also found in our previous research that  $m_1$  does not affect weight perception, but  $m_2$  does affect (Rahman et al., 2009a, 2011a). We also see that visual object sizes do not affect weight perception (Gordon et al., 1991). Results for two-way (visual object size, subject) analyses of variances separately analyzed on perceived weights for the two  $m_1$  and  $m_2$  sets showed that variations due to object sizes were insignificant ( $F_{2, 18} < 1$  for each  $m_1$  and  $m_2$  set). The reason may be that subjects estimated perceived weights using haptic cues where visual cues had no influences. Variations among subjects were also found statistically insignificant ( $F_{9,18} < 1$  for each  $m_1$  and  $m_2$  set).

The actual weight of the object was 0.2943 N, but the subjects felt about 0.052 N when the object was manipulated with the power assist robot system in horizontal direction. Hence, the results reveal that the perceived weight is about 18% of the actual weight if an object is manipulated horizontally with a power assist robot system. Its physical meaning is that the perceived weight of an object manipulated with power-assist in horizontal direction is 18% of the perceived weight of the same object manipulated in horizontal direction manually. This happens because the power assist robot system reduces the perceived weight through its assistance to the user. It is a well-known concept that a power assist robot system reduces the feeling of weight. However, it was not quantified. This research quantified the weight attenuation for horizontal manipulation of objects with the power assist robot system. As we found in our previous research, the perceived weight reduces to 40% and 20% of the actual weight if the object is vertically lifted (Rahman et al., 2011a) or vertically lowered (Rahman et al., 2011b) respectively. The weight perception is less for horizontal manipulation as the gravity force is compensated.

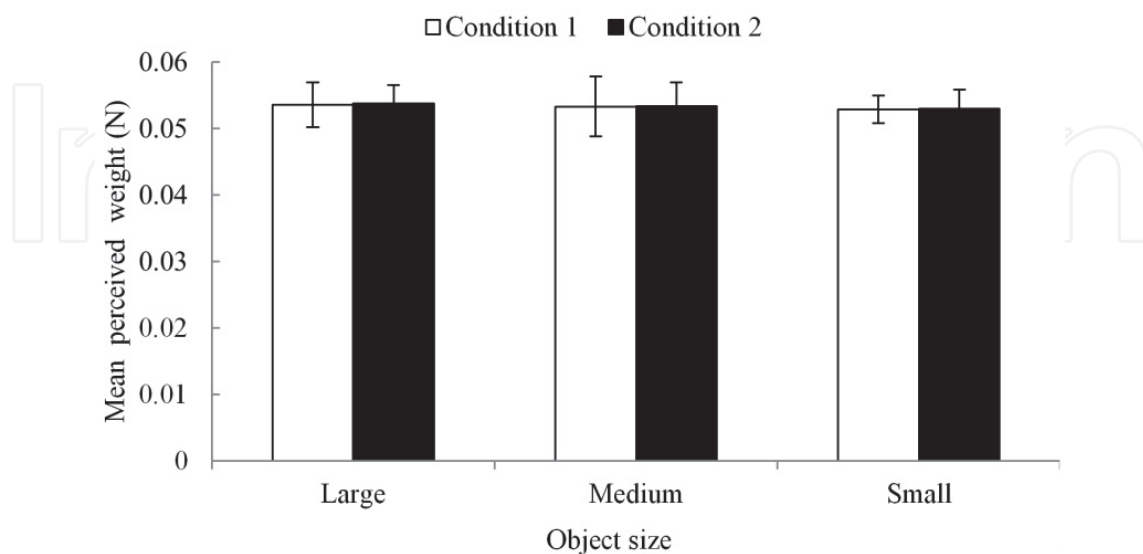

Fig. 8. Mean ( $n=10$ ) perceived weights for different object sizes for condition 1 ( $m_1=0.5\text{kg}$ ,  $m_2=0.03\text{kg}$ ) and condition 2 ( $m_1=1\text{kg}$ ,  $m_2=0.03\text{ kg}$ ).

### 3.6.3 Force analysis

The time trajectory of load force for a typical trial is shown in Fig.9. We derived the magnitude of peak load force (PLF) for each object size for condition 1 ( $m_1=0.5\text{kg}$ ,  $m_2=0.03\text{kg}$ ) and condition 2 ( $m_1=1\text{kg}$ ,  $m_2=0.03\text{kg}$ ) separately and determined the mean PLFs. The results are shown in Table 3. Results show that mean PLFs for condition 2 are slightly larger than that for condition 1. We found previously that both  $m_1$  and  $m_2$  are linearly proportional to peak load force. However,  $m_1$  affects load force, but it does not affect weight perception. On the other hand,  $m_2$  affects both load force and weight perception (Rahman *et al.*, 2011a). Here, we assume that larger  $m_1$  in condition 2 has produced larger load force.

We have already found that subjects feel the best maneuverability at  $m_1=0.5\text{kg}$ ,  $m_2=0.03\text{kg}$  and  $m_1=1\text{kg}$ ,  $m_2=0.03\text{kg}$ . On the other hand, actually required PLF to manipulate the power-assisted object should be slightly larger than the perceived weight (Gordon *et al.*, 1991), which is 0.052 N. We compared the perceived weights from Fig.8 to the PLFs (Table 3) for the large, medium and small objects and determined the excess in PLFs. The results show that subjects apply load forces that are extremely larger than the actually required load forces for condition 1 and 2. We also see that the magnitudes of PLFs are proportional to object sizes (Gordon *et al.*, 1991). We assume that the excessive load forces create problems in terms of maneuverability, safety, motions etc. that we discussed in the introduction.

### 3.6.4 Motion analysis

Fig.9 shows trajectories of displacement, velocity and acceleration for a typical trial. The figure shows that the time trajectories of load force and object's acceleration are synchronized i.e., when load force reaches the peak; acceleration also reaches the peak and so on. However, the trajectory of displacement is different from that of load force and acceleration i.e., the displacement is not entirely synchronized with load force and acceleration. Hence, we see that there is a time delay between PLF (peak acceleration as well) and peak displacement. Previously we assumed that the time delay is caused due to a delay in position sensing (Rahman *et al.*, 2010b), but this research reveals that the time delay may be caused by the combined effects of the time constant of the position sensor and the delay in adjusting the situation and motions by the subject. We also assume that the time delay may cause the feeling of reduced heaviness of the object manipulated with the power assist robot system.

We derived peak velocity and peak acceleration for each trial and determined their means for each object size in each condition separately as shown in Table 4 and Table 5 respectively. The results show that the velocity and accelerations are large. We assume that the large peak load forces have resulted in large accelerations that are harmful to the system in terms of maneuverability, safety, motions etc.

$m_1, m_2$ sets	Mean PLFs (N) with standard deviations (in parentheses) for different object sizes		
	Large	Medium	Small
$m_1=0.5\text{kg}, m_2=0.03\text{kg}$	2.9131(0.1307)	2.6020(0.1151)	2.4113(0.1091)
$m_1=1.0\text{kg}, m_2=0.03\text{kg}$	2.9764(0.2009)	2.6554(0.1552)	2.4602(0.1367)

Table 3. Mean peak load forces for different conditions for different object sizes

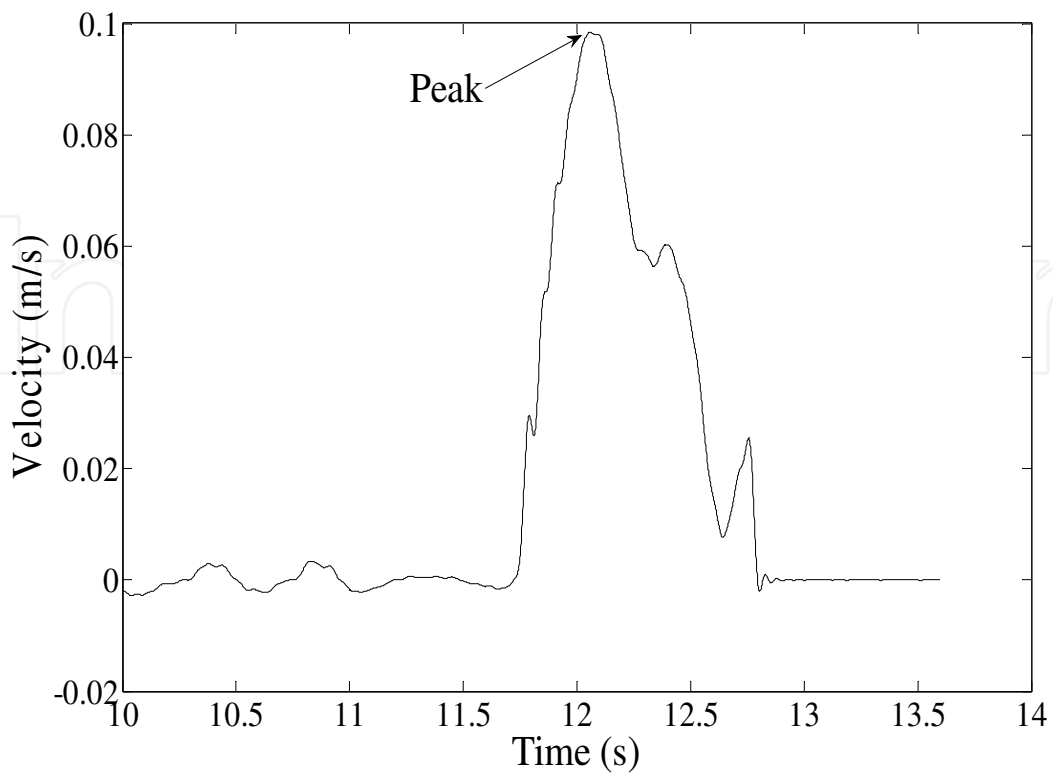
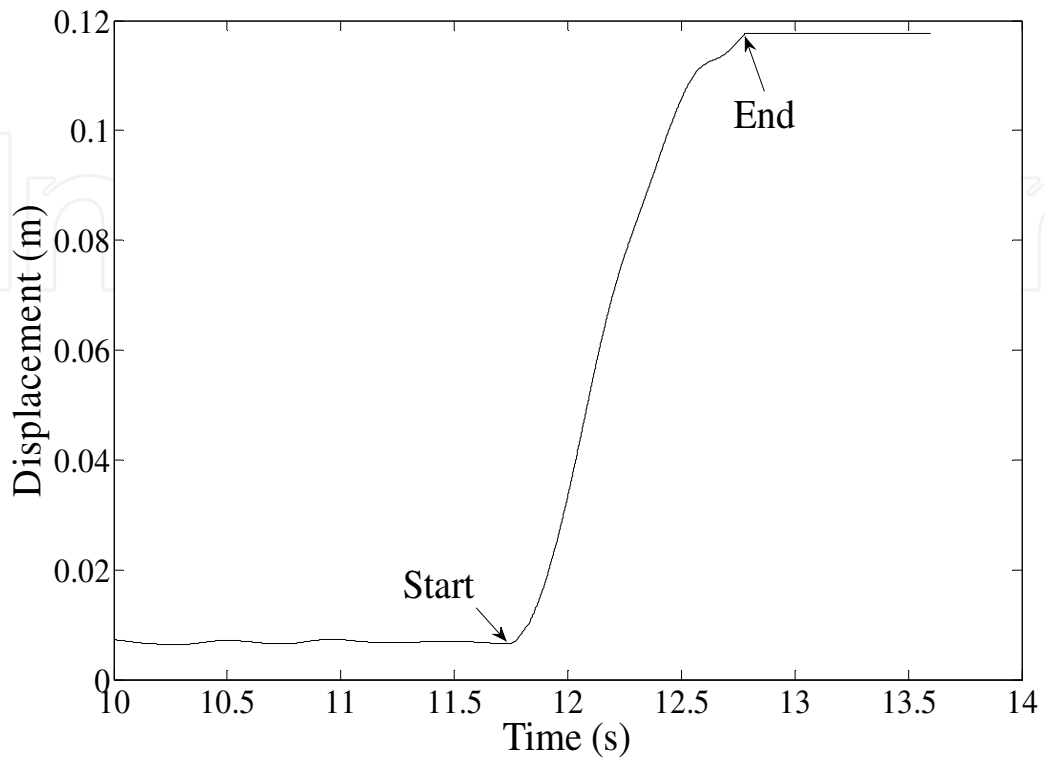

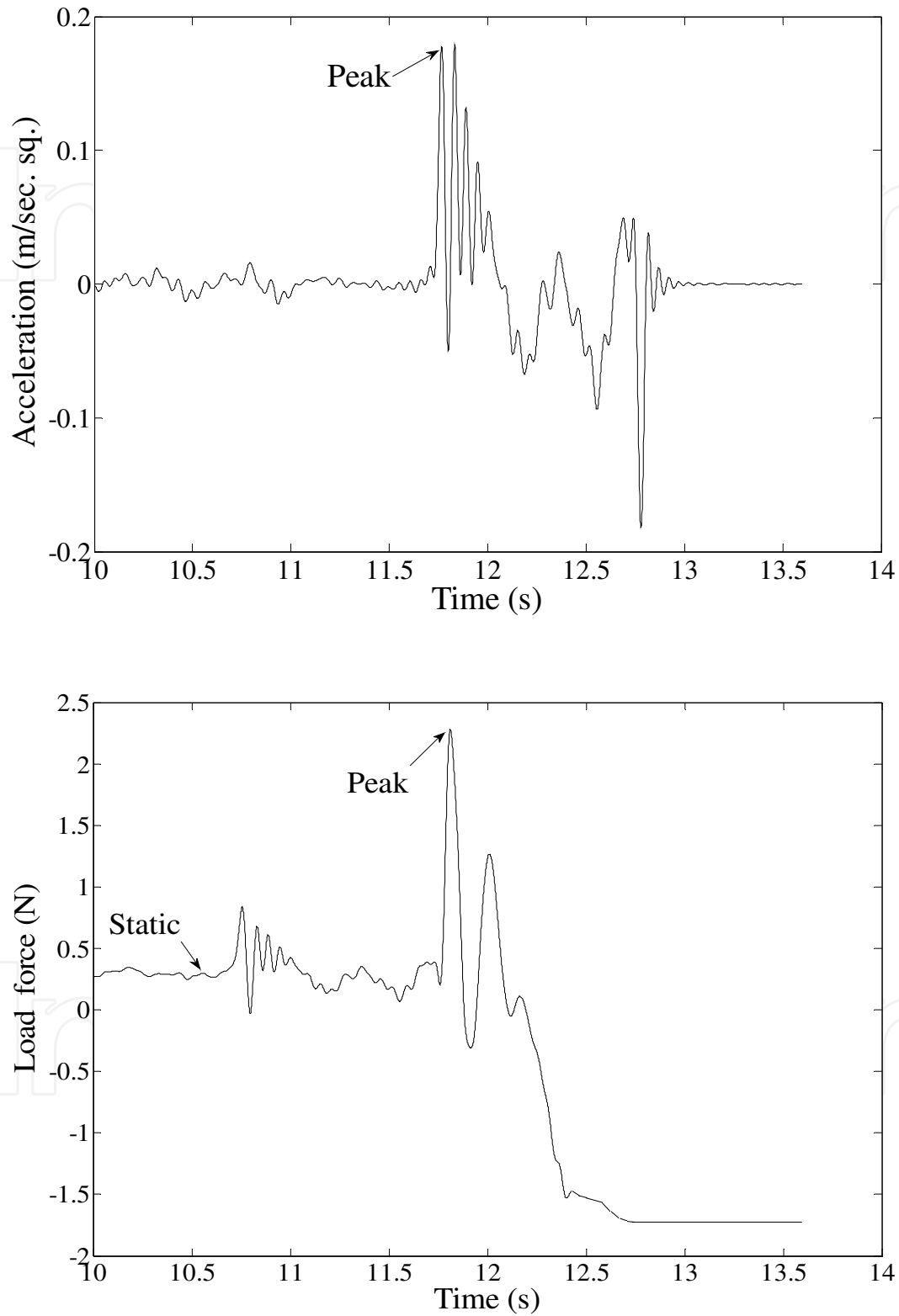

Fig. 9. Time trajectories of displacement , velocity , acceleration and load force for a trial when a subject manipulated the small size PAO with the system at condition 1 ( $m_1=0.5\text{kg}$ ,  $m_2=0.03\text{kg}$ ).

Object size	Mean peak velocity (m/s)	
	$m_1=0.5\text{kg}, m_2=0.03\text{kg}$	$m_1=1.0\text{kg}, m_2=0.03\text{kg}$
Large	0.1497(0.0149)	0.1557(0.0209)
Medium	0.1345(0.0157)	0.1399(0.0122)
Small	0.1098(0.0121)	0.1176(0.0119)

Table 4. Mean peak velocity with standard deviations (in parentheses) for different object sizes for different conditions

Object size	Mean peak acceleration (m/s <sup>2</sup> )	
	$m_1=0.5\text{kg}, m_2=0.03\text{kg}$	$m_1=1.0\text{kg}, m_2=0.03\text{kg}$
Large	0.2309 (0.0901)	0.2701 (0.0498)
Medium	0.2282 (0.0721)	0.2542(0.0153)
Small	0.1887(0.0298)	0.2134(0.0525)

Table 5. Mean peak accelerations with standard deviations (in parentheses) for different object sizes for different conditions.

#### 4. Experiment 2: Improving system performances by a novel control

##### 4.1 Experiment

Table 3 and Table 5 show that subjects apply too excessive load forces and accelerations that cause problems as we discussed in section 1. Experiment 2 attempted to reduce excessive load forces and accelerations by applying a novel control method.

The novel control was such that the value of  $m_1$  exponentially declined from a large value to 0.5kg when the subject manipulated the PAO with the system and the command velocity of Eq.(6) exceeded a threshold. We found previously that load force is linearly proportional to  $m_1$  and we also found that subjects do not feel the change of  $m_1$  (Rahman et al., 2011a). Hence, reduction in  $m_1$  would also reduce the load force proportionally. Reduction in load force would not adversely affect the relationships of Eq. (2) because the subjects would not feel the change of  $m_1$ . It means that Eq. (7) and Eq. (8) were used for  $m_1$  and  $m_2$  respectively to modify the control of Fig.5. The digit 6 in Eq. (7) was determined by trial and error. The novel control is illustrated in Fig.10 as a flowchart. The procedures for experiment 2 were the same as that for the experiment 1, but  $m_1$  and  $m_2$  were set as  $m_1=6 * e^{-6t} + 0.5, m_2=0.03$  (condition 1.a) and  $m_1=6 * e^{-6t} + 1.0, m_2=0.03$  (condition 2.a) for the simulation. Program for the simulation is shown in Fig.11. We here ignore presenting the simulation details for  $m_1=6 * e^{-6t} + 1.0, m_2=0.03$  because the concept and procedures for  $m_1=6 * e^{-6t} + 0.5, m_2=0.03$  and  $m_1=6 * e^{-6t} + 1.0, m_2=0.03$  are the same.

$$m_1=6 * e^{-6t} + 0.5 \tag{7}$$

$$m_2=0.03 \tag{8}$$

The system performances were broadly expressed through several criteria such as motion, object mobility, naturalness, stability, safety, ease of use etc., and in each trial in each scheme, the subjects subjectively evaluated (scored) the system using a 7-point bipolar and equal-interval scale as follows:

1. Best (score: +3)
2. Better (score: +2)



3. Good (score: +1)
4. Alike (score: 0)
5. Bad (score: -1)
6. Worse (score: -2)
7. Worst (score: -3)

## 4.2 Experiment results

### 4.2.1 Reduction in peak load forces and peak accelerations

We compared the mean PLFs of experiment 2 conducted at  $m_1=6 * e^{-6t} + 0.5$ ,  $m_2=0.03$  and  $m_1=6 * e^{-6t} + 1.0$ ,  $m_2=0.03$  to that of experiment 1 conducted at  $m_1=0.5$ ,  $m_2=0.03$  and  $m_1=1.0$ ,  $m_2=0.03$ . The findings are shown in Table 6. Findings show that PLFs reduced significantly due to the control modification.

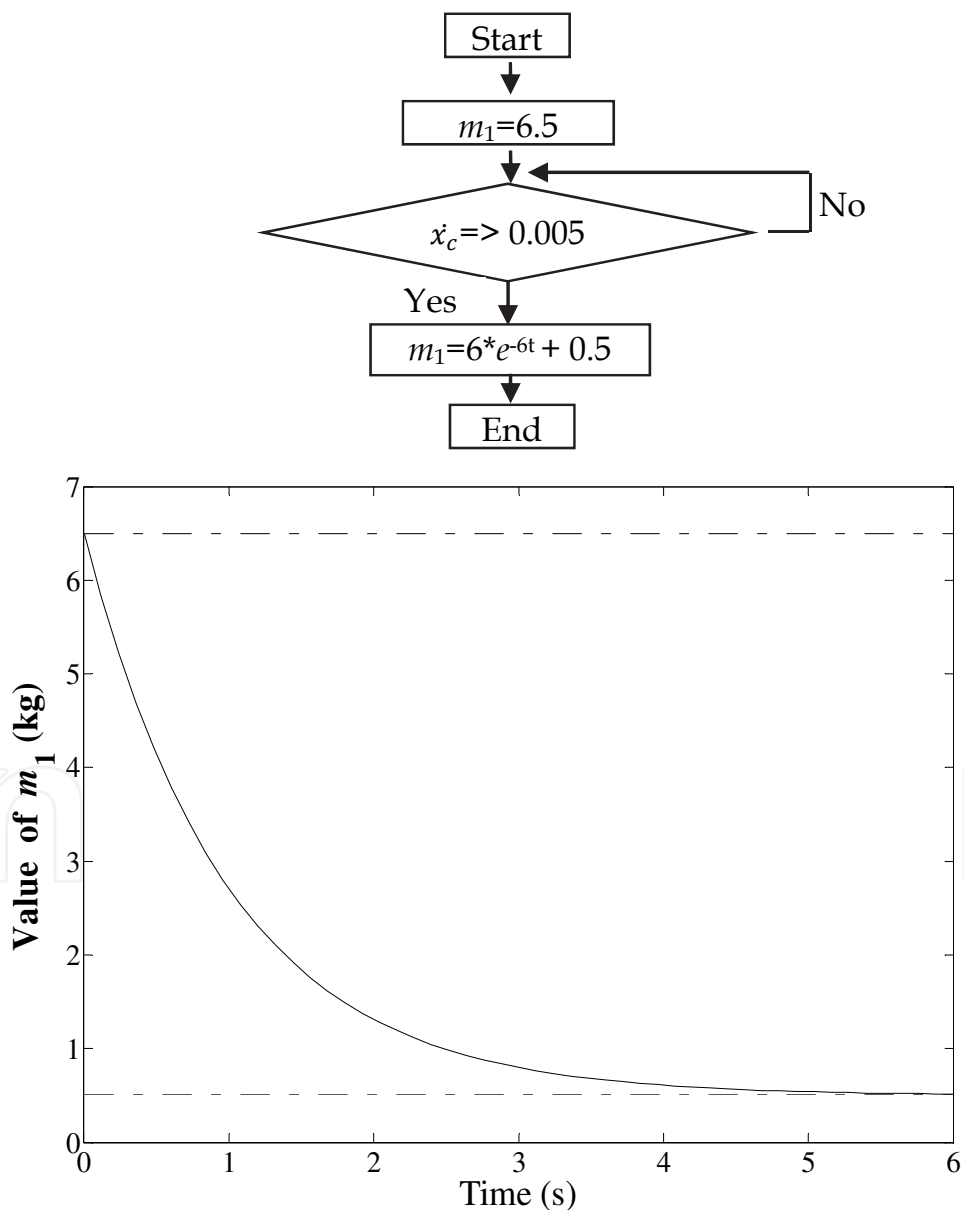

Fig. 10. Flowchart and hypothetical trajectory of inertial mass for the novel control technique.

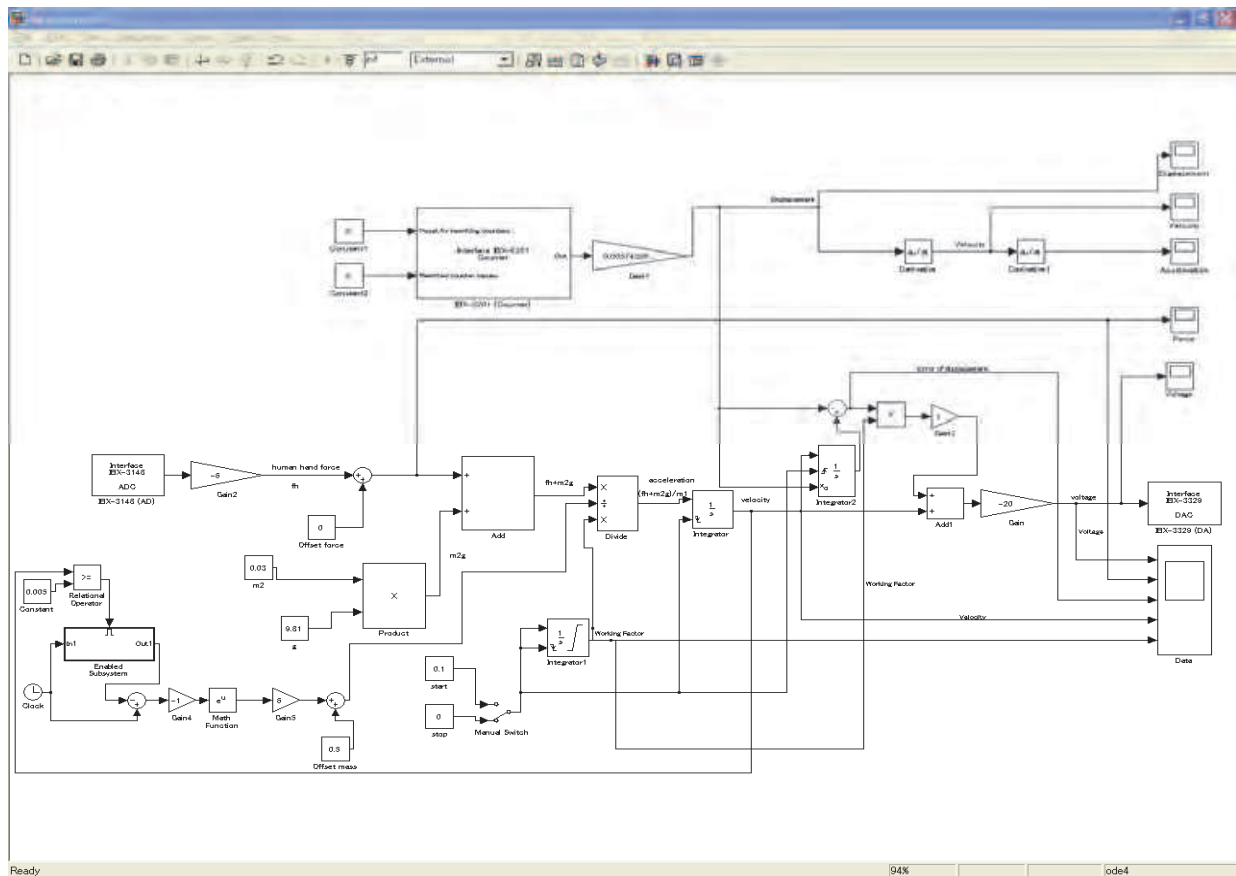

Fig. 11. The program for the simulation for the novel control method

Mean peak accelerations for different object sizes after the control modification are shown in Table 7. The results show, if we compare these to that of Table 5, that the peak accelerations reduced due to control modification. The reason may be that the reduced peak load forces after the control modification reduced the accelerations accordingly. The velocity did not change significantly due to the control modification.

#### 4.2.2 Improvement in system performances

We determined the mean evaluation scores for the three objects separately. Fig.12 shows the mean scores for the small size object for both conditions. The scores for the large and medium size objects in each condition were almost the same as that shown in the figure. It means that the novel control was effective in improving the system performances.

$m_1, m_2$ sets	Mean PLFs (N) with standard deviations (in parentheses) for different object sizes		
	Large	Medium	Small
$m_1=6 * e^{-6t} + 0.5,$ $m_2=0.03$	1.3569 (0.1154)	1.1123(0.0821)	0.9901(0.0910)
$m_1=6 * e^{-6t} + 1.0,$ $m_2=0.03$	1.8646 (0.1707)	1.5761(0.1071)	1.0990 (0.0885)

Table 6. Mean peak load forces for different conditions for different object sizes after the control modification

Object size	Mean peak acceleration (m/s <sup>2</sup> )	
	$m_1=6 * e^{-6t} + 0.5, m_2=0.03$	$m_1=6 * e^{-6t} + 1.0, m_2=0.03$
Large	0.1234 (0.0403)	0.1404 (0.0302)
Medium	0.1038 (0.0233)	0.1220 (0.0107)
Small	0.0884 (0.0311)	0.1008 (0.0164)

Table 7. Mean peak accelerations with standard deviations (in parentheses) for different object sizes for different conditions after the control modification

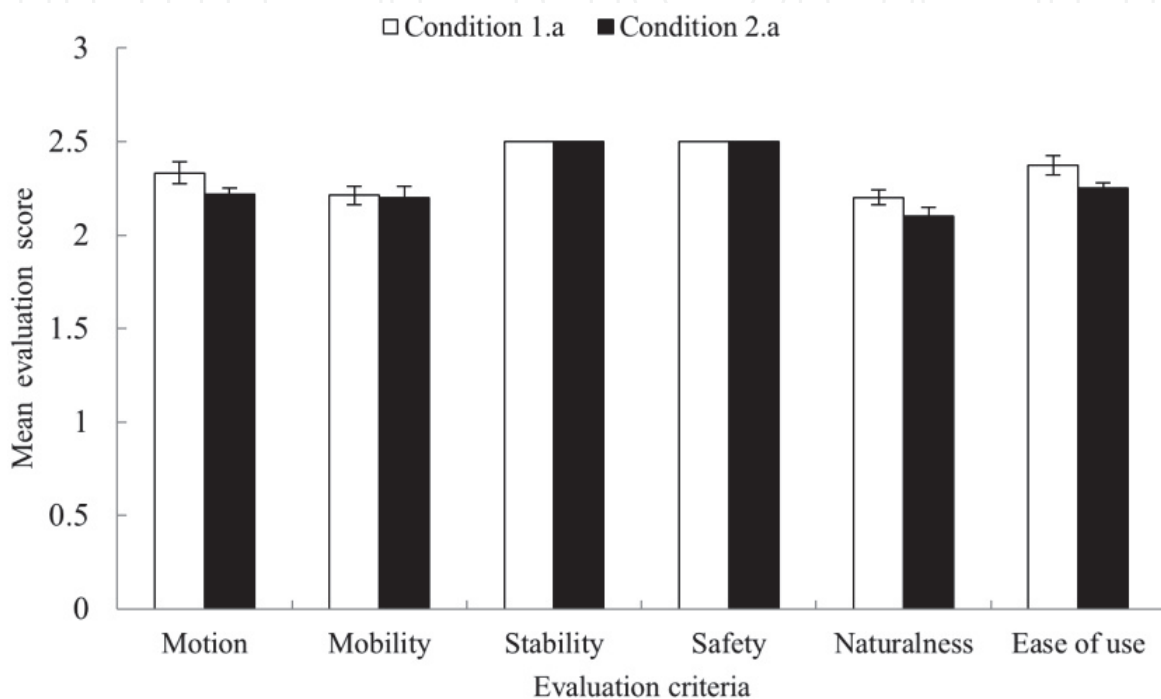

Fig. 12. Mean performance evaluation scores for small size object for condition 1.a ( $m_1=6 * e^{-6t} + 0.5, m_2=0.03$ ) and condition 2.a ( $m_1=6 * e^{-6t} + 1.0, m_2=0.03$ ) after the control modification.

## 5. Conclusions

In this chapter, we presented a 1-DOF power assist robot system for manipulating objects by human subjects in horizontal direction. We included human features in the robot dynamics and control. We determined optimum maneuverability conditions for manipulating objects with the robot system. We also determined psychophysical relationships between actual and perceived weights for manipulating objects with the robot system. We analyzed weight perception, load forces and motion characteristics. We implemented a novel control method based on weight perception, load forces and motion characteristics that improved the system performances through reducing the peak load forces and peak accelerations. The findings may help develop human-friendly power assist robot devices for manipulating heavy objects in industries such as manufacturing and assembly, mining, logistics and transport, construction etc. This chapter also provides a vivid example to the readers of how Matlab/Simulink is used to model and develop control system and interfaces between hardware and software for simulation and control of a robotic system. The findings of this chapter are novel and they enhance the state-of-the-art knowledge and applications of robotics, control system,

simulation, Matlab/Simulink, psychology, human factors etc. We will verify the results using heavy objects and real robotic systems in near future. The system will be upgraded to multi-degree of freedom system. Distinctions in weight perception, load forces and motion characteristics between unimanual and bimanual manipulation of objects in horizontal direction will be investigated.

## 6. Acknowledgment

The authors are thankful to the Ministry of Education, Culture, Sports, Science and Technology of Japan for financial supports.

## 7. References

- Bracewell, R.M., Wing, A.M., Scoper, H.M., Clark, K.G. (2003) 'Predictive and reactive coordination of grip and load forces in bimanual lifting in man', *European Journal of Neuroscience*, Vol.18, No.8, pp.2396-2402.
- Ding, M., Ueda, J., Ogasawara, T. (2008) 'Pinpointed muscle force control using a power-assisting device: system configuration and experiment', *In Proc. of IEEE Int. Conf. on Biomedical Robotics and Biomechatronics*, pp.181 - 186.
- Doi, T., Yamada, H., Ikemoto, T. and Naratani, H. (2007) 'Simulation of pneumatic hand crane type power assist system', *In Proc. of SICE Annual Conf.*, pp. 2321 - 2326.
- Dominjon, L., Lécuyer, A., Burkhardt, J.M., Richard, P. and Richir, S. (2005) 'Influence of control/display ratio on the perception of mass of manipulated objects in virtual environments', *In Proc. of IEEE Virtual Reality*, pp.19-25.
- Giachritsis, C. and Wing, A. (2008) 'Unimanual and bimanual weight discrimination in a desktop setup', M. Ferre (Ed.): *EuroHaptics 2008*, LNCS 5024, pp. 378-382.
- Gordon, A.M., Forssberg, H., Johansson, R.S., Westling, G. (1991) 'Visual size cues in the programming of manipulative forces during precision grip', *Exp. Brain Research*, Vol. 83, No.3, pp. 477-482.
- Hara, S. (2007) 'A smooth switching from power-assist control to automatic transfer control and its application to a transfer machine', *IEEE Trans. on Industrial Electronics*, Vol. 54, No. 1, pp.638-650.
- Kawashima, T. (2009) 'Study on intelligent baby carriage with power assist system and comfortable basket', *J. of Mechanical Science and Technology*, Vol.23, pp.974-979.
- Kazerooni, H. (1993) 'Extender: a case study for human-robot interaction via transfer of power and information signals', *In Proc. of IEEE Int. Workshop on Robot and Human Communication*, pp.10-20.
- Kong, K., Moon, H., Hwang, B., Jeon, D., Tomizuka, M. (2009) 'Impedance compensation of SUBAR for back-drivable force-mode actuation', *IEEE Trans. on Robotics*, Vol. 25, Issue: 3, pp.512 - 521.
- Kosuge, K., Yabushita, H., Hirata, Y. (2004) 'Load-free control of power-assisted cycle', *In Proc. of IEEE Technical Exhibition Based Conference on Robotics and Automation*, pp.111-112.
- Lee, H., Takubo, T., Arai, H. and Tanie, K. (2000) 'Control of mobile manipulators for power assist systems', *Journal of Robotic Systems*, Vol.17, No.9, pp.469-477.
- Lee, S., Hara, S., Yamada, Y. (2008) 'Safety-preservation oriented reaching monitoring for smooth control mode switching of skill-assist', *In Proc. of IEEE Int. Conf. on Systems, Man and Cybernetics*, pp.780-785.

- Liu, G., Yan, Y., Chen, J., Na, T. (2009) 'Simulation and experimental validation study on the drive performance of a new hydraulic power assist system', *In Proc. of IEEE Intelligent Vehicles Symposium*, pp.966-970.
- Lum, P.S., Reinkensmeyer, D.J., Lehman, S.L. (1993) 'Robotic assist devices for bimanual physical therapy: preliminary experiments', *IEEE Trans. on Rehabilitation Engineering*, Vol.1, No.3, pp.185-191.
- Marc, O.E., and Martin, S.B. (2002) 'Humans integrate visual and haptic information in a statistically optimal fashion', *Nature*, Vol. 415, No.6870, pp.429-433.
- Miyoshi, T. and Terashima, K. (2004) 'Development of vertical power-assisted crane system to reduce the operators' burden', *In Proc. of IEEE Int. Conference on Systems, Man and Cybernetics*, Vol.5, pp. 4420 - 4425.
- Osamura, K., Kobayashi, S., Hirata, M., Okamoto, H. (2008) 'Power assist control for slide doors using an ideal door model', *In Proc. of IEEE Int. Symposium on Industrial Electronics*, pp. 1293 - 1299.
- Rahman, S.M.M., Ikeura, R., Nobe, M., Sawai, H. (2009a) 'Design and control of a 1DOF power assist robot for lifting objects based on human operator's unimanual and bimanual weight discrimination', *In Proc. of IEEE Int. Conf. on Mechatronics and Automation*, pp.3637-3644.
- Rahman, S.M.M., Ikeura, R., Nobe, M., Sawai, H. (2009b) 'A psychophysical model of the power assist system for lifting objects', *In Proc. of IEEE Int. Conf. on Systems, Man, and Cybernetics*, pp.4125-4130.
- Rahman, S.M.M., Ikeura, R., Nobe, M., Sawai, H. (2010a) 'Study on optimum maneuverability in horizontal manipulation of objects with power-assist based on weight perception', *In Proc. of SPIE*, Vol. 7500, 75000P.
- Rahman, S.M.M., Ikeura, R., Nobe, M., Sawai, H. (2010b) 'Displacement-load force-perceived weight relationships in lifting objects with power-assist', *In Proc. of SPIE*, Vol. 7500, 75000S.
- Rahman, S.M.M., Ikeura, R., Nobe, M., Sawai, H. (2010c), 'Controlling a power assist robot for lifting objects considering human's unimanual, bimanual and cooperative weight perception', *In Proc. of IEEE Int. Conf. on Robotics and Automation*, pp.2356-2362.
- Rahman, S.M.M., Ikeura, R., Hayakawa, S. and Sawai, H. (2011a) 'Design guidelines for power assist robots for lifting heavy objects considering weight perception, grasp differences and worst-cases', *Int. J. Mechatronics and Automation*, Vol. 1, No. 1, pp.46-59.
- Rahman, S.M.M., Ikeura, R., Ishibashi, S., Hayakawa, S., Sawai, H., Yu, H. (2011b) 'Lowering objects manually and with power-assist: distinctions in perceived heaviness, load forces and object motions', *In Proc. of 4th IEEE International Conference on Human System Interactions*, 19-21 May, 2011, Yokohama, Japan, pp.129-135.
- Seki, H., Iso, M., Hori, Y. (2002) 'How to design force sensorless power assist robot considering environmental characteristics-position control based or force control based-', *In Proc. of Annual Conf. of IEEE Industrial Electronics Society*, Vol.3, pp.2255-2260.
- Seki, H., Ishihara, K., Tadakuma, S. (2009) 'Novel regenerative braking control of electric power-assisted wheelchair for safety downhill road driving', *IEEE Trans. on Industrial Electronics*, Vol. 56, No. 5, pp. 1393-1400.
- Tanaka, T., Satoh, Y., Kaneko, S., Suzuki, Y., Sakamoto, N. and Seki, S. (2008) 'Smart suit: soft power suit with semi-active assist mechanism - prototype for supporting waist and knee joint', *In Proc. of Int. Conf. on Control, Automation and Systems*, pp. 2002-2005.



## **MATLAB for Engineers - Applications in Control, Electrical Engineering, IT and Robotics**

Edited by Dr. Karel Perutka

ISBN 978-953-307-914-1

Hard cover, 512 pages

**Publisher** InTech

**Published online** 13, October, 2011

**Published in print edition** October, 2011

The book presents several approaches in the key areas of practice for which the MATLAB software package was used. Topics covered include applications for: -Motors -Power systems -Robots -Vehicles The rapid development of technology impacts all areas. Authors of the book chapters, who are experts in their field, present interesting solutions of their work. The book will familiarize the readers with the solutions and enable the readers to enlarge them by their own research. It will be of great interest to control and electrical engineers and students in the fields of research the book covers.

### **How to reference**

In order to correctly reference this scholarly work, feel free to copy and paste the following:

S. M. Mizanoor Rahman, Ryojun Ikeura and Haoyong Yu (2011). Modeling, Simulation and Control of a Power Assist Robot for Manipulating Objects Based on Operator's Weight Perception, MATLAB for Engineers - Applications in Control, Electrical Engineering, IT and Robotics, Dr. Karel Perutka (Ed.), ISBN: 978-953-307-914-1, InTech, Available from: <http://www.intechopen.com/books/matlab-for-engineers-applications-in-control-electrical-engineering-it-and-robotics/modeling-simulation-and-control-of-a-power-assist-robot-for-manipulating-objects-based-on-operator-s>

**INTECH**  
open science | open minds

### **InTech Europe**

University Campus STeP Ri  
Slavka Krautzeka 83/A  
51000 Rijeka, Croatia  
Phone: +385 (51) 770 447  
Fax: +385 (51) 686 166  
[www.intechopen.com](http://www.intechopen.com)

### **InTech China**

Unit 405, Office Block, Hotel Equatorial Shanghai  
No.65, Yan An Road (West), Shanghai, 200040, China  
中国上海市延安西路65号上海国际贵都大饭店办公楼405单元  
Phone: +86-21-62489820  
Fax: +86-21-62489821

© 2011 The Author(s). Licensee IntechOpen. This is an open access article distributed under the terms of the [Creative Commons Attribution 3.0 License](#), which permits unrestricted use, distribution, and reproduction in any medium, provided the original work is properly cited.

IntechOpen

IntechOpen