

We are IntechOpen, the world's leading publisher of Open Access books Built by scientists, for scientists

4,800

Open access books available

122,000

International authors and editors

135M

Downloads

Our authors are among the

154

Countries delivered to

TOP 1%

most cited scientists

12.2%

Contributors from top 500 universities



WEB OF SCIENCE™

Selection of our books indexed in the Book Citation Index
in Web of Science™ Core Collection (BKCI)

Interested in publishing with us?
Contact book.department@intechopen.com

Numbers displayed above are based on latest data collected.

For more information visit www.intechopen.com



Wavelet Fault Diagnosis of Induction Motor

Khalaf Salloum Gaeid and Hew Wooi Ping

University of Malaya

Malaysia

1. Introduction

The early 1980s saw the emergence of wavelets, an analysis tool that drew a lot of attention from scientists of various disciplines, mathematicians in particular, due to its promising applications.

The roots of wavelet techniques go back to 1807, when Joseph Fourier presented his theories of frequency analysis. By the 1930s, investigations were being carried out on scale-varying basis functions that would conserve energy in the computation of functional energy. Between 1960 and 1980, Guido Weiss and Ronald R. Coifman studied the reconstruction of functional elements using 'atoms'. Later, Grossman and Morlet would provide a quantum physics definition of wavelets. Stephane Mallat made an important contribution to the development of wavelets through his work in digital signal processing in 1985. The first non-trivial, continuously differentiable wavelets were created by Y.Meyer. Not long after, Ingrid Daubechies constructed a set of orthonormal basis functions that form the foundation of modern day wavelet applications (Nirmesh Yadav et al, 2004).

The present demand in the industry is for high performance electric drives that are capable of achieving speed commands accurately. Control methods have had to reach higher levels of sophistication accordingly. Induction motors, with their advantages in terms of size, cost and efficiency, are best suited to meet these growing needs (Khalaf Salloum Gaeid&Hew Wooi Ping, 2010).

In costly systems, maintenance and protection are especially essential in the prevention of system breakdowns and catastrophes. Thanks to advances in signal processing technology, it is now possible to utilize wavelet principles to efficiently diagnose and protect industrial induction motors.

Motor Current Signature Analysis (MCSA) of the stator current with wavelet to detect the fault in a broken rotor bar in the transient region was done by (Douglas et al, 2003).The analysis of the sensorless control system of induction motor with a broken rotor for diagnostics using wavelet techniques has been presented by (Bogalecka et al, 2009). (Zhang et al, 2007), used the empirical model decomposition(EMD) which deals with nonlinear systems to detect the broken rotor bar using wavelet discrete transform (WDT).(Cao Zhitong et al, 2001), used the multi resolution wavelet analysis (MRA) method to detect broken rotor bars according to the analysis of stator current. The signal was filtered, differentiated and then supplied to the Daubechies wavelet with 5 levels. (Faiz, Ebrahimi et al, 2007) presented a novel criterion to detect the broken rotor bar using time stepping finite element (TSFE) to model the broken bar faults in induction motor. (Yang et al, 2007), presented a novel method to detect the rotor broken bar using Ridge wavelet. In this paper, only one phase of the

stator currents was shown to be enough to extract the characteristics of the frequency component of broken bar. (Pons-Llinares et al, 2009), presented a new method to detect a broken bar in the transient region using time motor current signature analysis (TMCSA) via frequency B-Splines. (Pineda-Sanchez et al, 2010), used fractional Fourier transform as a spectral analysis tool with the TMCSA to detect the rotor broken bar. The single mean square of discrete wavelet function computation measures whether the status of the broken rotor bar of the induction motor is healthy or faulty, using Field Programmable Gate Array (FPGA). A novelty to the weighting function was introduced by (Ordaz Moreno et al, 2008). (Abbas zadeh et al, 2001) presented a novel approach to detect the broken bar fault in squirrel cage induction motors. Two 3 HP induction motors with cast aluminum rotor bars were employed for this experiment. (Cabal-Yepez et al, 2009), used FPGA to detect a number of faults in the squirrel cage such as unbalance, faulty bearing and broken bars using parallel combination of fused fast Fourier transform (FFT) and wavelet. (J. Antonino-Daviu et al, 2009) presented new techniques for the detection of broken bars using high order discrete wavelet (db40) and compared it with classical methods such as the Fourier transform. To remedy the shortcomings of the FFT, (Cusido, Rosero et al, 2006) introduced spectral density on the wavelet to detect many faults in the induction motor for different load conditions (7% and 10%). A few issues were seen to feature in the use of the MCSA method for fault detection, especially when the load torque was varied. (Cusido et al, 2007 & Cusido et al, 2010) presented an online system for fault detection using many wavelets like the Mexican Hat, Morlet and the Agnsis mother wavelet to detect broken bar faults.

The drawbacks of using FFT, like corrupted frequency components, the noises or other phenomena such as load torque fluctuations or supply voltage oscillations (J. Pons-Llinares et al, 2010), have been investigated by many authors for detection of broken rotor bars. The Daubechies (db) is commonly employed as the mother function to avoid low level overlapping with adjacent bands.

A 0.1 Hz resolution to detect faults in an induction motor using a combination of wavelets and power spectral density was obtained by (Hamidi et al, 2004).

The fault detection in the transient region for a broken rotor bar using the instantaneous power FFT as a medium for fault detection was presented by (Douglas, H & Pillay, P, 2005). A wavelet was used to decompose the residual stator current after filtering the noise using a Notch filter.

The wavelet indicator for detecting the broken rotor bars by calculating the absolute values of the summed coefficients in the third pattern which were normalized against the summation of the wavelet coefficient, the number of scales, and the number of samples used was presented by (Supangat et al, 2006 & Supangat et al, 2007).

The V/F control to detect a broken rotor bar in the induction motor was made according to the probability distribution of different operation statuses of healthy and faulty motors used by (Samsi et al, 2006). In this paper, the difference in entropy was used as a measurement indication of fault.

DWT to detect the broken rotor bar in the transient region using the slip dependant fault component according to the energy ratio of the current signal to the wavelet signal was done by Riera-Guasp et al, 2008).

The detection of the broken rotor bar fault using optimized DWT and FFT in the steady state was proposed by (J. Antonino et al, 2006). (Kia et al, 2009) presented a discrete wavelet transform (DWT) for broken bar detection and diagnosis faults in induction machines in which an energy test of bandwidth with time domain analysis is performed first, after which

it is applied to the stator current space vector to obtain the different broken bar fault severities and load levels.

Eigen vector as a fault indicator of stator inter turn short circuit using the Eigen vector and an energy Eigen value which contain the necessary information of the electromagnetic torque signal was presented by (Liu & Huang, 2005).

The finite element (FE) modelling of the internal faults of an induction motor. They solved the equation by the time stepping approach of a broken bar and stator shorted turns using db10 wavelet for both sinusoidal and non-sinusoidal cases has been used by (Mohammed et al, 2006& Mohammed et al, 2007).

Software diagnosis of short inter turn circuit and open circuit of the stator winding as an incipient fault was performed by (Ponci et al, 2007) to avoid any hardware cost and difficulty using wavelet decomposition for different values of stator resistance.

The MCSA technique and a wavelet to detect faults but performed the stator teeth harmonic variation using dq0 components instead of stator currents (I_{abc}) was done by (Cusido et al, 2006). (Gang Niu et al, 2008) employed Bayesian belief fusion and multi agent fusion as a classifier tool to detect different faulty collected data using the signal processing techniques for smoothing and then used DWT to decompose the signals into different ranges of frequency.

Detection and diagnosis for rotor asymmetries in the induction motor based on the analysis of the stator start-up current has been done by (M. Riera-Guaspá et al, 2009). The authors extracted the harmonic component introduced by this fault. The left sideband component from the stator startup current, digital low-pass filtering (DLPF) and (DWT) are used in this technique. (C. Combastel et al, 2002) presented a comparison between model-based and signal-based approaches in the fault detection of the induction motor. The electrical variables are described according to the Park transformation model. Broken rotor and stator winding failures were investigated and the parameter variations due to heating were taken into account. (S. Radhika et al, 2010), in her MCSA-based fault diagnosis, classified WT extracted features using a Support Vector Machine (SVM). (Chen & Loparo, 1998) proposed the computation of a fault index for the stator winding faults. (Khan & Rahman, 2006) used two DWT to detect and classify the faults.

The continuous wavelet is a part of the wavelet used to detect faults especially when the overlapping between the frequency supply signal and the adjacent signal cannot be recognized. The work presented by (Ayaz et al, 2006) involved the use of six accelerometers that measured the vibration data of 5 kW and were put in independent places around the motor to detect the bearing damage.

A new technique for detecting and diagnosing faults in both stator and rotor windings using wound rotor induction motor was presented by (Saleh et al, 2005). This technique is based on a wavelet transform multi resolution analysis (WTMRA). (Cusido et al, 2007) presented both continuous and discrete wavelet to detect many mechanical and electrical induction motor faults using MCSA. (Sayed-Ahmed et al, 2007) studied the inter-turn short circuit in one phase of a stator winding of an induction motor energized from a vector controlled drive.

The induction motor requires a variable frequency three phase source for variable speed operation. One can realize this source by using a power converter system consisting of a rectifier connected to an inverter through a DC link.

In some control schemes where a three phase, variable frequency current source is required, current control loops are added to force the motor currents to follow an input reference.

Vector control techniques have been widely used for the high performance drive of induction motors. Like DC motors, torque control of induction motor is achieved by controlling the torque and flux components independently (Mohamed Boussak and Kamel Jarray, 2006). The similarities between DC and vector control are why the latter is referred to as decoupling, orthogonal or trans-vector control (Archana S. Nanoty, and A. R. Chudasama, 2008).

In this chapter, we investigate the use of the wavelet in the fault detection of vector-controlled induction motors, detection of the broken rotor bar and stator short winding faults as well as the verification of wavelet fault detection models using MATLAB.

Finally, two approaches for the protection of induction motor are examined. The first uses the Automatic Gain Control (AGC) to compensate the voltage of the induction motor to maintain satisfactory operation. The second halts operation when the fault severity becomes high. Without delving into excessively detailed results, we analyse the output relevant to wavelet detection and diagnosis.

2. Model of induction motor

The d-q dynamic model of the squirrel cage induction motor with the reference frame fixed to the stator is given by (Anjaneyulu, N .Kalaiarasi and K.S.R 2007):

$$V_s = R_s i_s + \frac{d\lambda_s}{dt} + j\omega_s M\lambda_s \quad (1)$$

$$V_r = R_r i_r + \frac{d\lambda_r}{dt} + (\omega_s - \omega_r)M\lambda_r \quad (2)$$

The electromagnetic torque is found as:

$$T_e = \frac{2pL_m}{3L_r} (i_{qs}i_{dr} - i_{ds}i_{qr}) \quad (3)$$

$$T_e = \frac{2pL_m}{3L_r} (i_{qs}\varphi_{dr} - i_{ds}\varphi_{qr}) \quad (4)$$

$$\varphi_{ds} = L_r i_{dr} + L_m i_{ds} \quad (5)$$

The field orientation is based on the following assumption:

$$\varphi_{qr} = 0 \quad (6)$$

$$\varphi_{dr} = \text{constant} \quad (7)$$

The (vector) field orientation control performs the following calculations

$$\begin{bmatrix} i_{qs} \\ i_{ds} \end{bmatrix} = \begin{bmatrix} \cos \varphi_s & \sin \varphi_s \\ -\sin \varphi_s & \cos \varphi_s \end{bmatrix} \quad (8)$$

d-q to abc transformation is:

$$\begin{bmatrix} i_{as} \\ i_{bs} \\ i_{cs} \end{bmatrix} = \begin{bmatrix} 1 & 0 \\ -0.5 & -\sqrt{3}/2 \\ -0.5 & \sqrt{3}/2 \end{bmatrix} \begin{bmatrix} i_{qs} \\ i_{ds} \end{bmatrix} \tag{9}$$

Accordingly, the rotor flux and the torque can be controlled individually through the stator current in the dq-axis so that the induction motor is transformed to a linear current and torque relationship.

3. Vector control of the induction motor

Vector control was invented by Hasse in 1969 and by Blaschke in 1972 when they demonstrated that an induction motor can be controlled like a separately excited dc motor. This brought a renaissance in the high performance control of AC drives.

Vector control of the squirrel cage induction motor is considered a fast response and high performance method to achieve variable speeds using a variable frequency source as shown in Fig.1

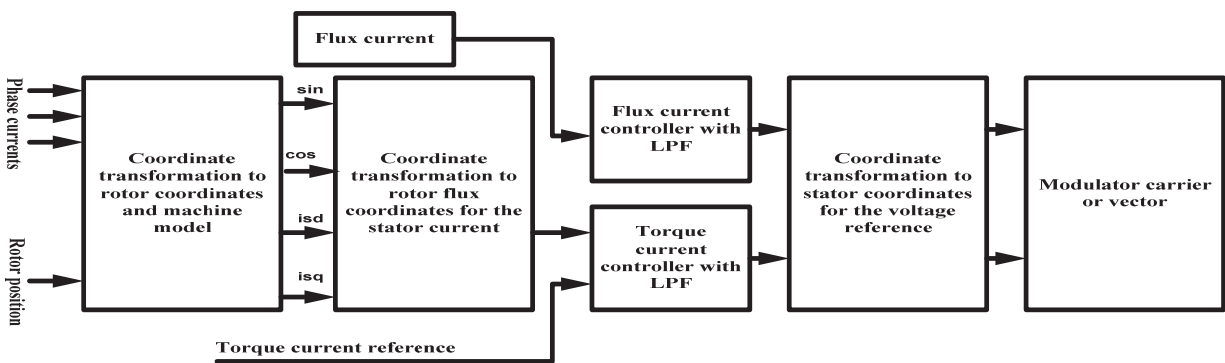

Fig. 1. Vector control principle

In the vector control method, the induction motor can be operated like a separately excited DC motor for high performance applications.

To achieve better performance, numerous speed closed loop systems have been improved. However, desired drive specifications still cannot be perfectly satisfied and/or their algorithms are too complex (J.L. Silva Neto&Hoang Le-Huy, 1996) as shown in Fig.2.

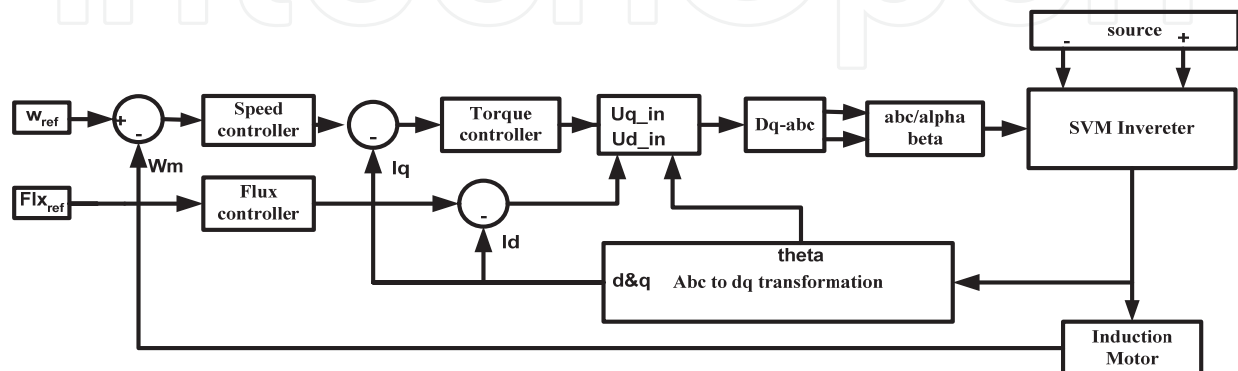

Fig. 2. Vector control implementation

Vector controlled machines need two constants as input references; the torque component (aligned with the q-axis coordinate) and the flux component (aligned with d-axis coordinate) which is simply based on projections as the control structure handles instantaneous electrical quantities. This behavior yields accurate control in both the steady state and transients and is independent of the bandwidth mathematical model of the induction motor.

Vector control is an especially advantageous solution to the problem of motor control because the torque and flux components of stator flux are easily accessible. Besides, it is free from a number of complexities that beset direct torque control (BPRA073, 1998).

There are two different strategies in vector control to obtain the rotor flux:

- Indirect control, in which the rotor flux vector is either measured by a flux sensor mounted in the air-gap or measured using the voltage equations starting from the electrical machine parameters.
- Direct control, in which the rotor flux parameter can be calculated by direct rotor speed measurement.

The condition to apply vector control to induction motors is the formulation of dynamic model equations to calculate and control the variables (AN2388, 2006) as can be seen in Fig.3, which shows the Simulink implementation of vector control using the current regulation technique. Note that both the magnitude and phase alignment of vector variables is controlled.

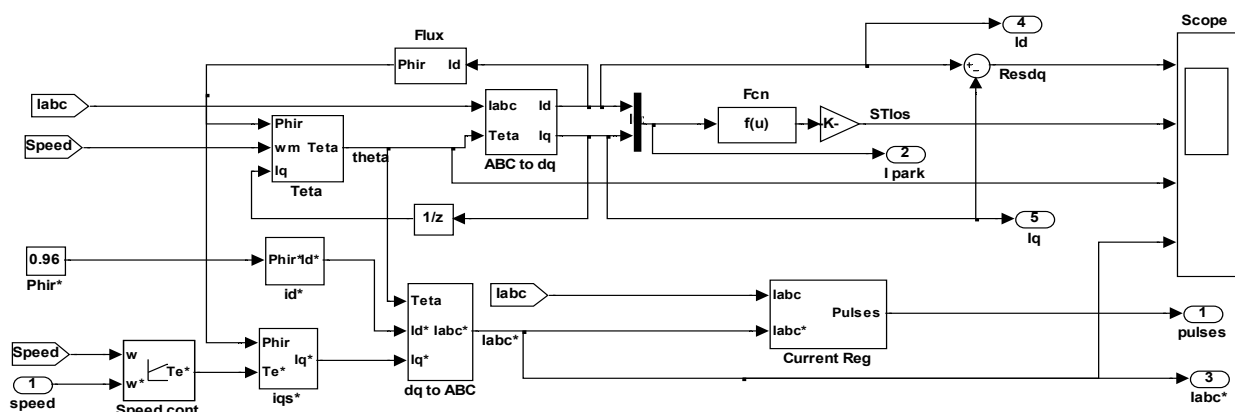

Fig. 3. Vector control implemented using Simulink.

4. Discrete wavelet transform fault detection

Wavelet techniques are new in the field of fault diagnosis. They are useful due to their ability to extract all the information in both time and frequency domain. They provide a sensitive means to diagnose the faults in comparison to other signal processing methods like the Fourier Transform, the drawbacks of which include the need to use a single window function in all frequency components and the acquisition of linear resolution in the whole frequency domain. This is an important reason for the interest in wavelets in time–frequency analysis as can be seen in (M. Riera-Guaspa et al, 2009). (Andrew K.S. et al, 2006) presented a review of the diagnosis of machines using the condition-based maintenance approach. There are two levels of fault diagnosis:

1. Traditional control
2. Knowledge based fault diagnosis

Fault diagnosis techniques contain the feature extraction module (wavelet), feature cluster module and the fault decision module (1). Indicators of faults include the negative sequence current, impedance and the Park's vector.

Motor Current Signature Analysis (MCSA) is used to diagnose the stator short circuit fault.

Multi resolution analysis and good time localization are particularly useful characteristics of wavelets in the context of fault diagnosis.

Signal processing techniques like the FFT are based on the assumptions of constant stator fundamental frequency, load, motor speed and the assumption that the load is sufficient. Wavelet transformation is of many kinds but in this chapter the authors will introduce the most important among them:

1. Discrete wavelet transformation
2. Continuous wavelet transformation
3. Wavelet packet decomposition transformation

The wavelet is divided into two main groups. One is the discrete wavelet transform represented in the following Eq.:

$$DWT(m, k) = \frac{1}{\sqrt{a_0^m}} \sum x(n) g\left(\frac{k - nb_0 a_0^m}{a_0^m}\right) \quad (10)$$

Where $g(n)$ is the mother wavelet $x(n)$ is the input signal and the scaling and translation parameters " a " and " b " are functions of the integer parameter m (M. Sushama et al, 2009).

The second wavelet type is the continuous wavelet transform (CWT) which can be represented as follows:

$$\omega(m, n) = \int_{-\infty}^{\infty} f(t) \psi_{m, n}^*(t) dt \quad (11)$$

* denotes the complex conjugate, where $f(t)$ is the waveform signal and $\psi(t)$ is a wavelet.

$$\psi_{m, n}(t) = 2^{-1/2} \psi(2^{-m}t - n) \quad (12)$$

Where m and n are the wavelet dilation and translation used to transform the original signal to a new one with smaller scales according to the high frequency components. This relation is valid for the orthogonal basis of wavelet transform ($a=2$ and $b=1$). In the following continuous wavelet transform, a is the scale parameter, b is the time parameter.

$$\omega_{a, b}(t) = |a|^{-1/2} \psi\left(\frac{t-b}{a}\right) \quad (13)$$

CWT is divided into the Real wavelet as can be seen in table 1 and the Complex wavelet as in table 2.

In digital computers, the discrete wavelet transform is a good choice. The mother wavelet is scaled to the power of 2 (R. Salehi Arashloo & A. Jalilian, 2010).

The continuous wavelet transform (CWT) was developed as an alternative approach to overcome the resolution problem as is shown in Table 1 (Lorand SZABO et al, 2005).

Beta Wavelet	$\psi_{beta}(t/\alpha, \beta) = (-1)dp(t/\alpha, \beta)/dt$
Hermitian Wavelet	$\psi_n(t) = (2n)^{-n/2} C_n H_n(t/\sqrt{2}) e^{-(1/2n)t^2}$
Mex.hat wavelet	$\psi(t) = (2/\sqrt{3}\sigma\pi^{1/4})(1-t^2/\sigma^2)e^{-(t^2/2\sigma^2)}$
Shannon wavelet	$\psi(t) = 2\sin c(2t) - \sin c(t)$

Table 1. Continuous real wavelet transform

Mexican hat wavelet	$\psi(t) = \frac{2}{\sqrt{3}}\pi^{-0.25} \left(\sqrt{\pi}(-t^2)e^{-0.5t^2} - \sqrt{2}it\sqrt{\pi}\operatorname{erf}\left(\frac{i}{\sqrt{2}}t\right)(1-t^2)e^{-0.5t^2} \right)$
Morlet wavelet	$\psi(t) = (C\pi^{-(1/4)})e^{-1/2t^2}(e^{it} - k)$
Shannon wavelet	$\psi(t) = \sin c(t)e^{-j\pi t}$
Modified Morlet wavelet	$\psi(t) = C_\psi \cos(\omega_o t) \operatorname{sech}(t)$

Table 2. Continuous complex wavelet transform

Two properties of the wavelet are noteworthy:

1. When a wavelet satisfies an admissibility condition, a signal with finite energy can be reconstructed without needing all values of its decomposition. The admissibility condition is represented by the following equation:

$$\int \frac{|\psi(\omega)|^2}{|\omega|} d\omega < +\infty \quad (14)$$

Where $\psi(\omega)$ is the Fourier transform of the wavelet function $\psi(t)$ used to investigate the signals and then to reconstruct them without losing any information. According to the admissibility condition, the Fourier transform goes to zero as is shown in the following equation:

$$|\psi(\omega)|^2 = 0 \quad (15)$$

Another important property of the wavelet is:

$$\int \psi(\omega) = 0 \quad (16)$$

2. To remedy the squared relationship between the time bandwidth product of the wavelet transform and the input signal, certain regularity conditions are imposed so as to ensure the smoothness and concentration of the wavelet function in both time and frequency domains.

The decomposition can be implemented using filtering and down-sampling, and can be iterated, with successive approximation as in (Turkmenoglu, 2010).

The total decomposition levels (L) can be calculated according to the following relationship:

$$L \geq \frac{\log(f_s/f)}{\log(2)} + 1 \quad (17)$$

These bands can't be changed unless a new acquisition with different sampling frequency is made, which complicate any fault detection based on DWT, particularly in time-varying conditions (Yasser Gritli et al, 2011).

When (18) is applied at a sampling frequency of 1 kHz, a six level decomposition occurs. Table 3 depicts the frequency bands for each wavelet signal.

$$L = \frac{\log(1000/50)}{\log(2)} + 1 = 6 \text{ levels} \quad (18)$$

Approximations «aj»	Frequency bands (Hz)	Details «dj»	Frequency bands (Hz)
a ₆	[0-16.125]	d ₆	[16.125-32.25]
a ₅	[0-32.25]	d ₅	[32.250-64.5]
a ₄	[0 - 64.50]	d ₄	[64.50-125.0]
a ₃	[0 - 125.0]	d ₃	[125.0-250.0]
a ₂	[0- 250.0]	d ₂	[250.0-500.0]
a ₁	[0-500.0]	d ₁	[500.0-1000.0]

Table 3. Frequency bands for the six levels of wavelet signals

The data required to analyze the signal depends on both the sampling frequency () and the resolution (R) as in (19):

$$D_{\text{required}} = f_s / R \quad (19)$$

The interpretation of the above table is shown in Fig 4:

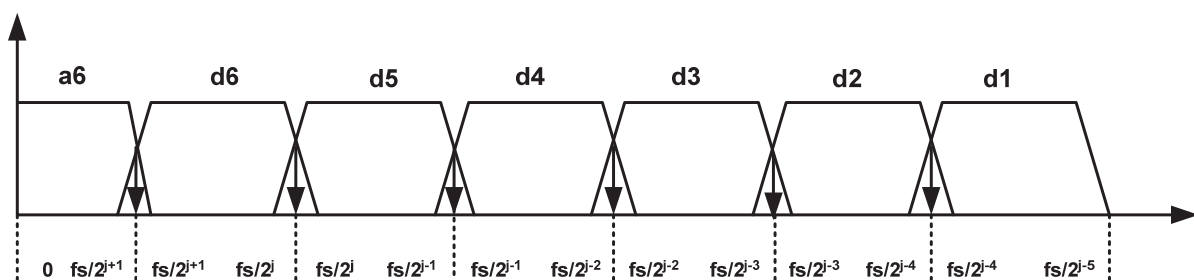

Fig. 4. Frequency range covers for details and final approximation

The MATLAB signal processing toolbox software provides the Filter Design and Analysis tool (FDA Tool) that enables the design of a low pass filter and high pass filter and then export the filters coefficients to a matching filter implemented as can be seen in the Fig.5.

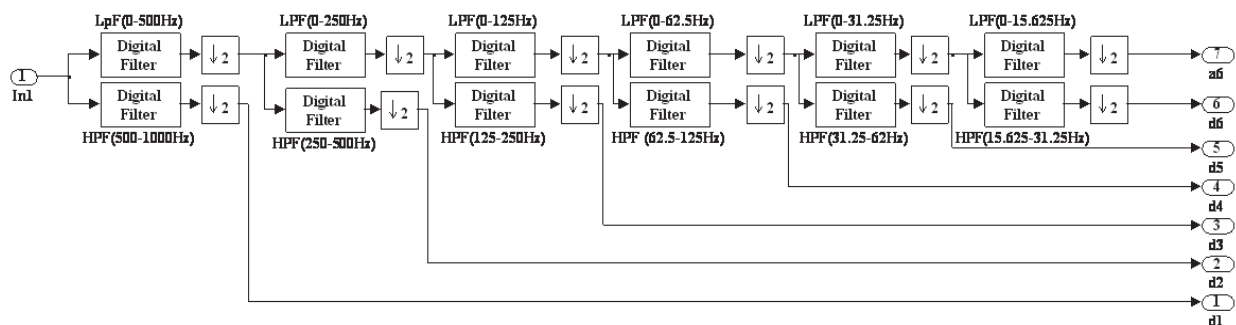

Fig. 5. Wavelet decomposition levels using FDA matlab tool box

An alternative way to performing the same task is through the DWT dyadic filter from MATLAB/Simulink. Although for this method, the wavelet coefficients may need to be calculated using the following MATLAB instruction:

$$[Lo_D, Hi_D, Lo_R, Hi_R] = wfilters('db10') \quad (20)$$

Where Lo_D, Hi_D, Lo_R, Hi_R represent low pass filter decomposition, high pass filter decomposition, low pass filter reconstruction and high pass filter reconstruction respectively. This is shown in Fig.6.

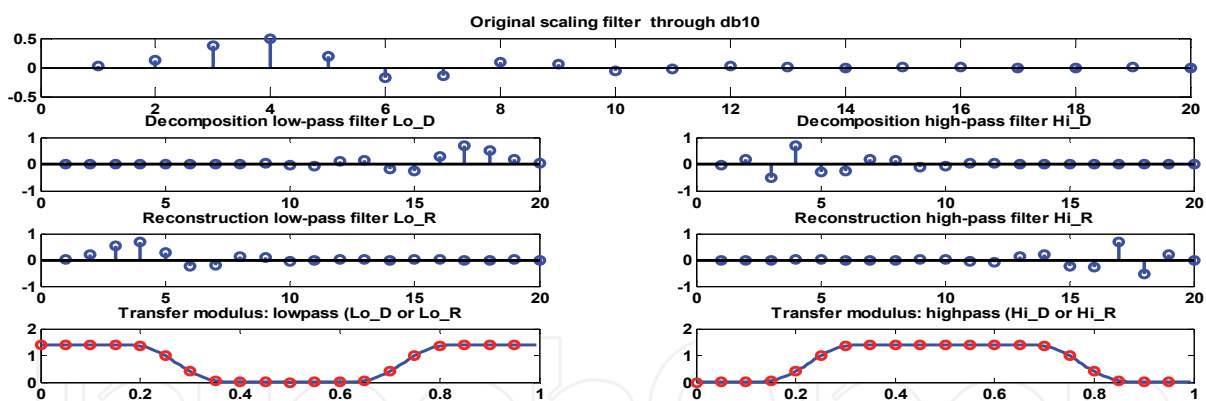

Fig. 6. Wavelet decomposition and reconstruction filters

The decomposition of the wavelets was implemented using the above relation as can be seen in Fig.7.

The above two circuits are exactly the same. A wavelet-transform-based method was developed for diagnosis and protection the induction motor against broken rotor bar and short stator windings. Detailed information is obtained from the high pass filters and the approximation information is obtained from low pass filter. Daubechies wavelet (db10) is used to analyze stator current as in Fig8.

The construction of DWT is followed by implementing the criterion of fault detection of induction motor faults. The criteria used to detect the induction motor faults depend on the relationship between maximum detail energy ($d6$) and the original stator current (I_a) as is shown in Fig.9.

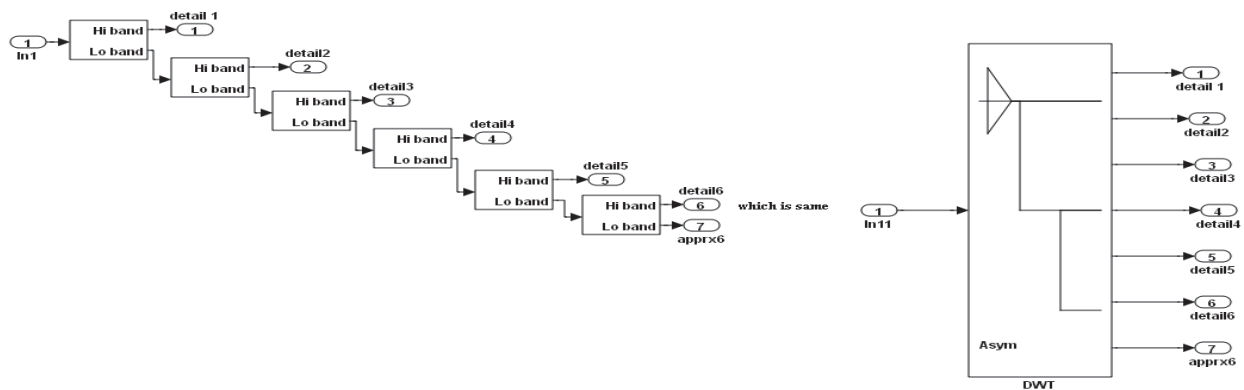

Fig. 7. DWT filters and levels using simulink

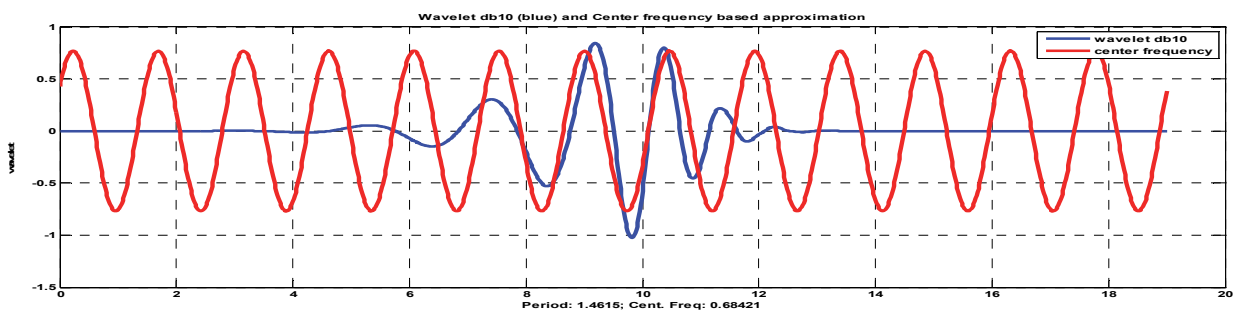

Fig. 8. Daubechies wavelet (db10) and central frequency

Offline calculations of maximum energy were done using MATLAB instructions as in the following wavelet program:

load Ia

[C, L] = wavedec (Ia, 6,'db10');

[Ea, Ed] = wenergy(C, L)

Ea is the percentage of energy corresponding to the approximation, Ed is the vector containing the percentages of energy corresponding to the details, C is the wavelet decomposition vector and L is the bookkeeping vector.

Ea = 99.5370(a6)

Ed =0.0000(d1) 0.0000(d2) 0.0000(d3) 0.0001(d4) 0.0010(d5) 0.4619(d6)

The Wavelet coefficients, the energy of the details of any signal at level j can be expressed as (M. Sabarimalai Manikandan, and S. Dandapat, 2007):

$$E_j = \sum d_{j,k}^2 \tag{21}$$

$$d_{j,k} = \langle x(t), \psi_{j,k} \rangle = \frac{1}{\sqrt{2^j}} \int x(t) \psi(2^j t - k) dt \tag{22}$$

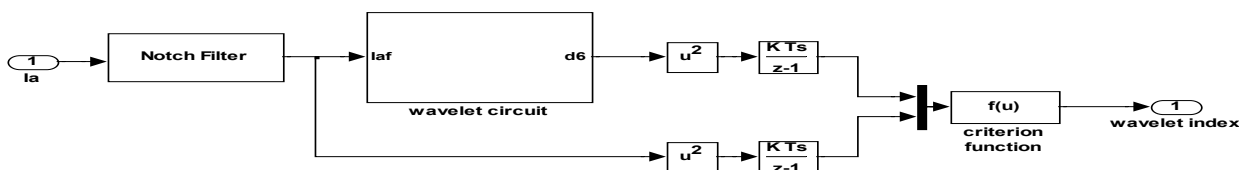

Fig. 9. Wavelet index unit with conditioning signal

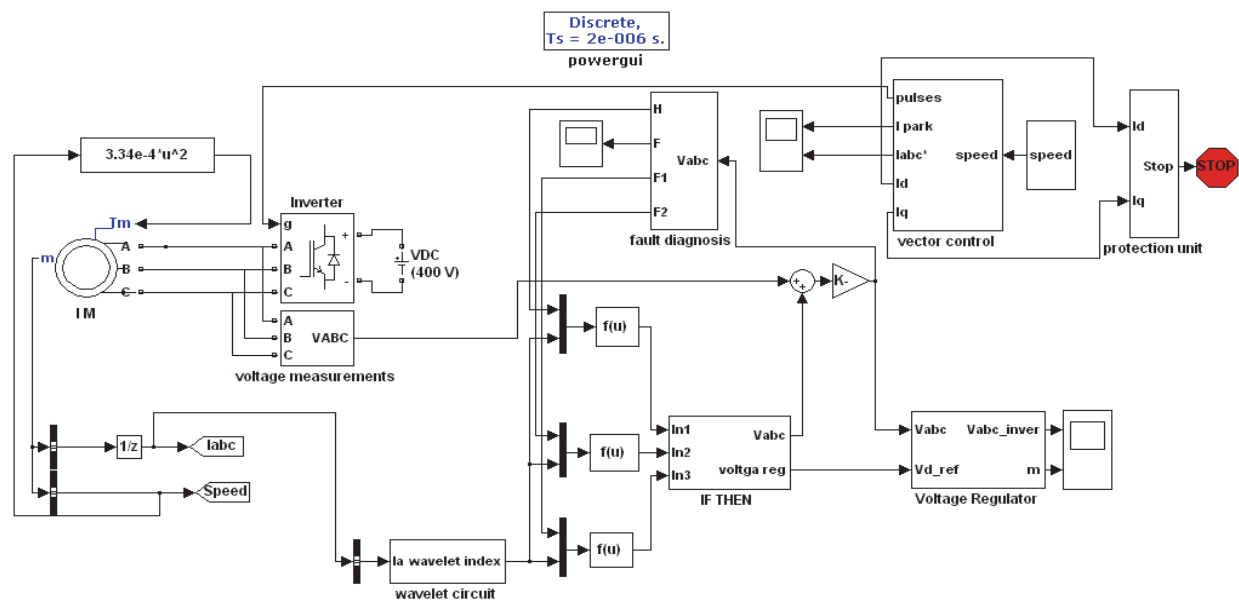

Fig. 10. Proposed circuit of induction motor fault diagnosis with wavelet

M. specifications	Unit	Value
power	w	370
Current	ampere	1.7
Voltage (delta)	volt	230
Rated speed	RPM	2800
No. of pole		2
Moment of inertia	Kgm ²	3.5e-4
Stator resist.	ohm	24.6
Rotor resist.	ohm	16.1
Stator induct.	henry	40e-3
Rotor induct.	henry	40e-3

Table 4. Induction motor specifications

5. Fault detection

Electric drives are used in safety-critical applications or industrial processes where the immense costs of unplanned stops are unacceptable. Fault detection depends on the availability of information from the system. In this work, the fault detection is done using wavelet for analysis of stator current as can be shown in Fig.11 for the healthy case, Fig.12 for broken rotor bar case and Fig.13 for the stator short winding case respectively.

The wavelet criterion of fault detection is:

$$W_{indx} = \text{abs}(\text{energy}(d6)) / \text{average}(\text{energy}(Ia)) \quad (23)$$

In MATLAB/Simulink, an assessment of operating features of the proposed scheme is performed. Two faults are investigated: stator short winding and broken rotor bar.

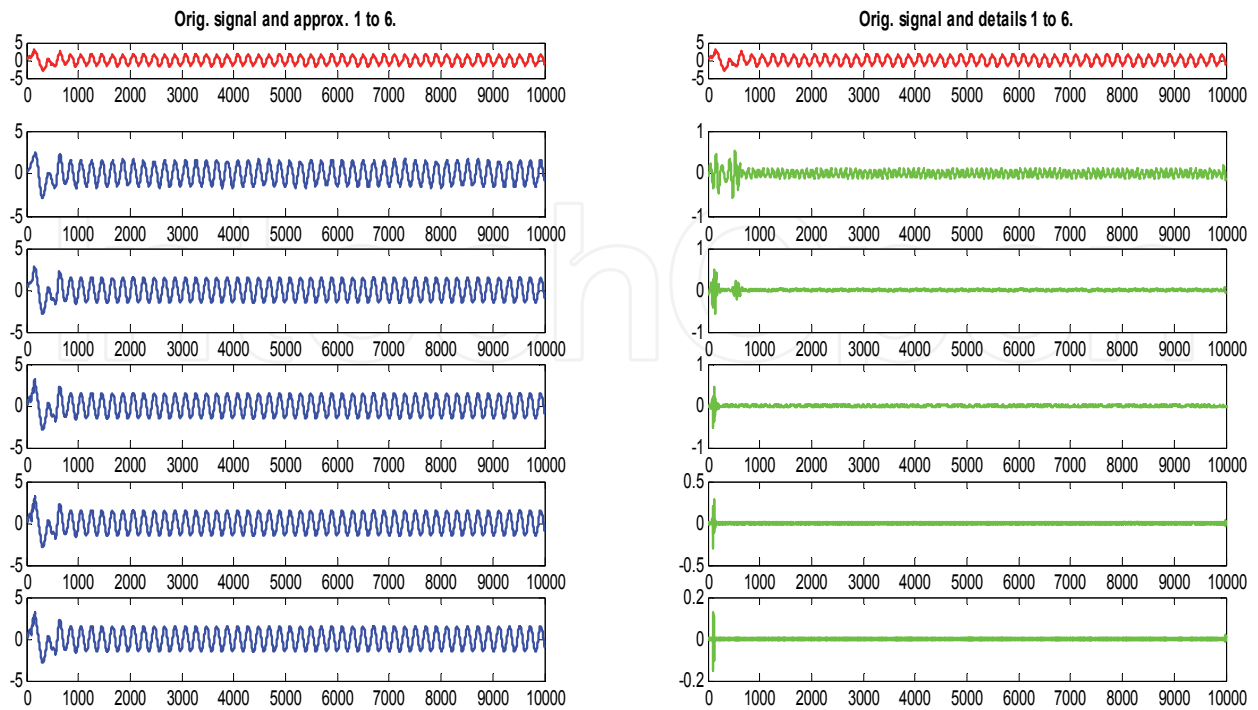

Fig. 11. Approximation and details signal in healthy motor

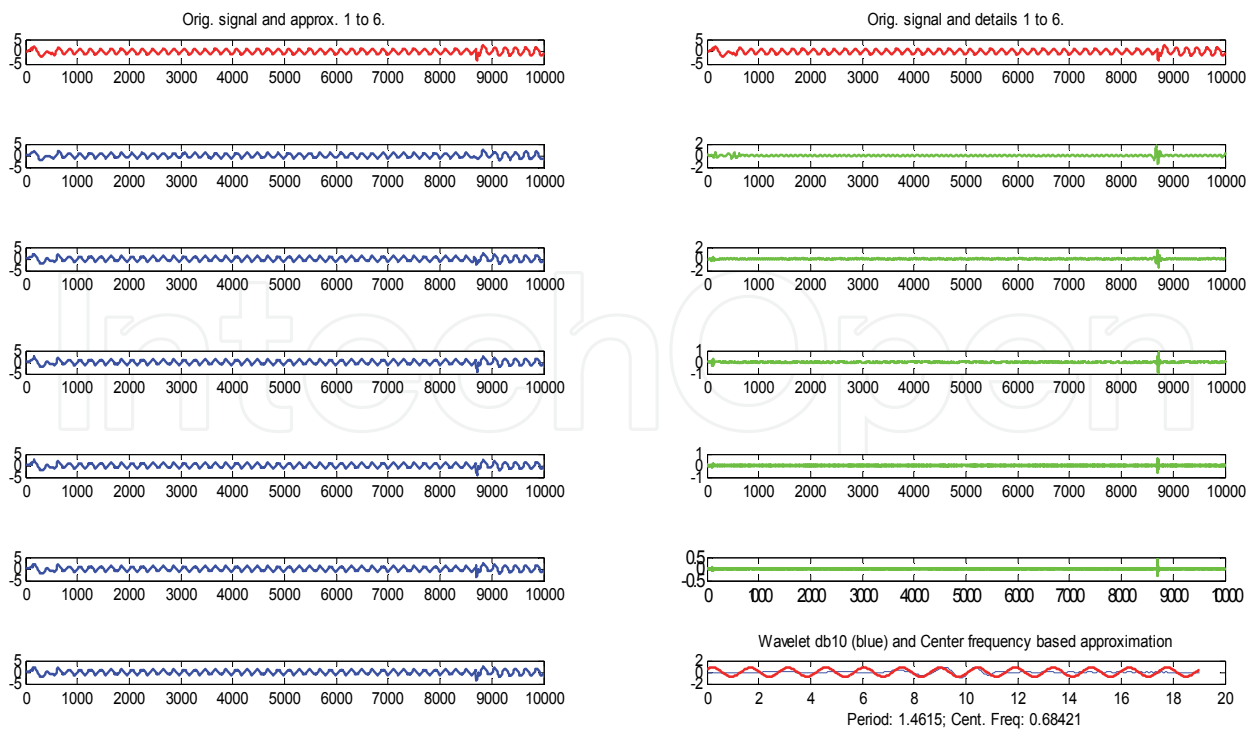

Fig. 12. Approximation and details signal in one broken rotor bar fault

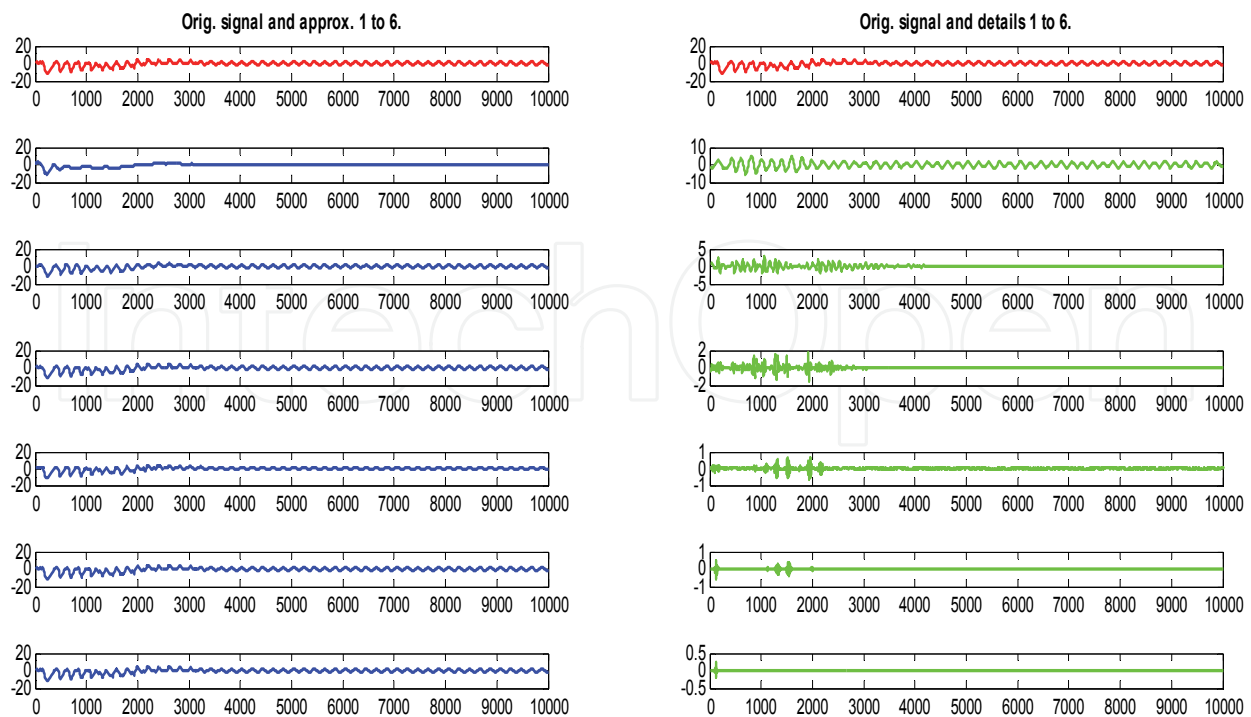

Fig. 13. Approximation and details signal in short stator winding fault

This wavelet is also used as fault indicator or wave index as is shown in Fig14.

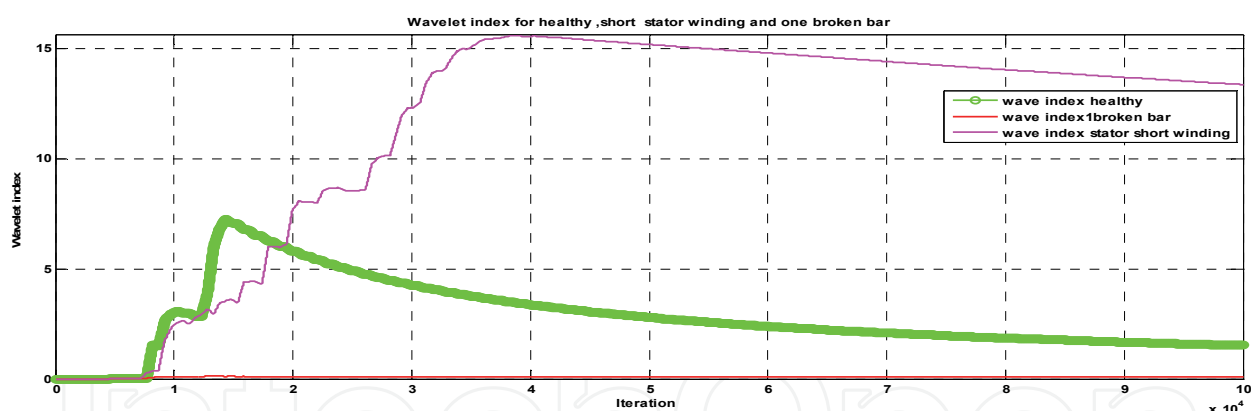

Fig. 14. Wavelet index for fault detection

5.1 Broken rotor bar

Key reasons for a broken rotor bar are (Ahmed Y. Ben Sasi et al, 2006):

1. Direct on line starting which leads to excessive heating and mechanical problems.
2. Variable mechanical load.
3. Unsatisfactory rotor cage manufacturing.

Broken rotor bar faults can be simulated by connecting three resistances with the rotor resistance so that by increasing one of the rotor phase resistances, the broken rotor bar equivalent resistance can be computed as in (24).

$$R_{brk} \cong (0.33 / 4) R_r z_{nb} / N^2 s \quad (24)$$

The external added resistances are changed in 0.0833Ω steps, which represents the difference between the reference rotor resistance and the original rotor resistance for one broken rotor bar. Reference rotor resistance depends on the number of broken bars and the total number of rotor bars (Hakan Calis & Abdulkadir Cakır, 2007). The resistance of induction motor rotor bar is assumed to be high.

(Levent Eren, & Michael J. Devaney, 2004), presented the bearing fault defects of the induction motor WPT decomposition of 1 Hp induction motor stator current through the test of RMS for both healthy and faulty bearings.

5.2 Stator shorting the winding

More than 30% of all motor faults are caused by failure of the motor winding due to insulation problems. For the stator short circuit winding fault, the stator resistance of the induction motor is connected to the parallel variable resistance which is reduced according to the following formula:

$$R_{sh} = 0.1R_{org} \quad (25)$$

The majority of induction motor winding failures proceed gradually from lower short circuit current to a higher level and finally break as can be seen in (Dimas et al, 2010).

To check the validity of the wavelet fault detection of both stator winding and broken rotor bar units as well as when the motor is in a healthy condition, MATLAB/Simulink's Predicted Model Block (PED) is used to verify the wavelet detection units as is shown in subsequent figures.

In the healthy induction motor, transfer function of the wavelet unit (interval test) is:

$$G_{healthy} = \frac{-1.3e-166z^3 + 8.2e-167z^2}{z^4 - 0.5z^3 - 0.5z^2 + 7.7067e-8z - 1.1592e-8} \quad (26)$$

And the noise model of unit is:

$$G_{Noise} = \frac{z^4 + 0.0027766z^3 + 0.00025661z^2}{z^4 - 2.3152z^3 + 1.2203z^2 + 0.5013z - 0.40632} \quad (27)$$

The predicted and noise model of the wavelet detection unit in the healthy case is shown in Fig15.

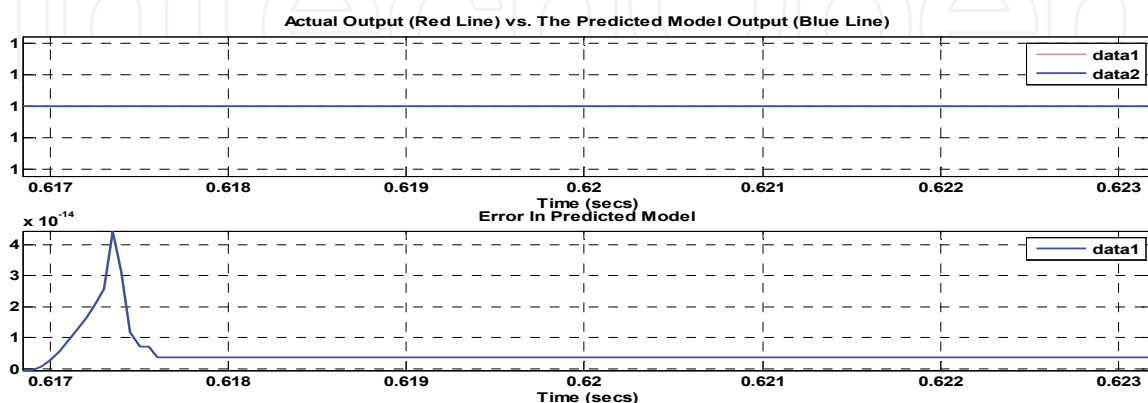

Fig. 15. Predicted model output and its noise model for wavelet detection unit in the healthy case

In the stator short winding fault, transfer function of the wavelet unit (interval test) is:

$$G_{statorshort} = \frac{1.1665e-158z^3 - 2.2477e-158z^2}{z^4 - 0.5z^3 - 0.5z^2 + 2.9406e-10z - 3.5998e-11} \quad (28)$$

The noise model of the unit is:

$$G_{noisemodel} = \frac{z^4 + 0.0020325z^3 - 0.00119535z^2}{z^4 - 2.4623z^3 + 1.4434z^2 + 0.5z - 0.48113} \quad (29)$$

The predicted and noise model of the wavelet detection unit in this case is shown in Fig16.

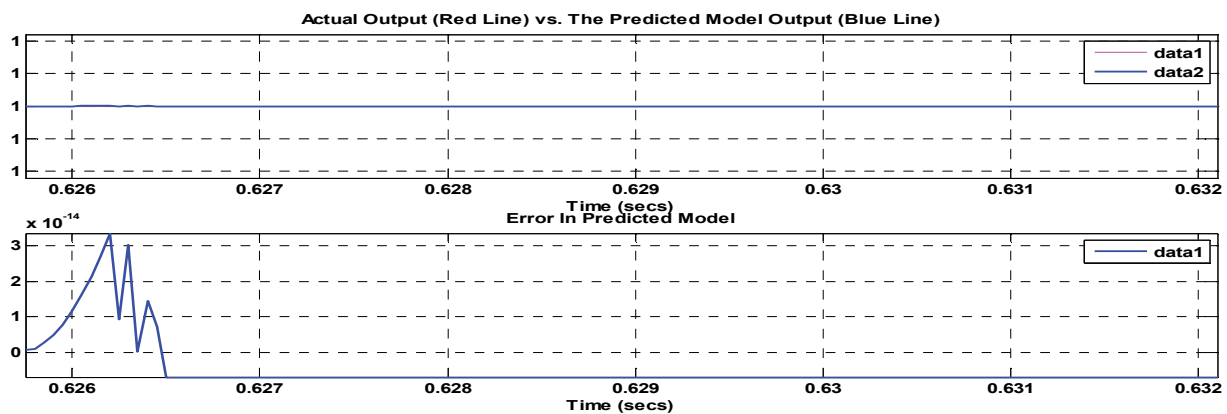

Fig. 16. predicted model output and its noise model for wavelet detection unit in the stator short winding case

In the broken rotor bar fault, transfer function of the wavelet unit (interval test) is:

$$G_{brokenbar} = \frac{1.17382e-159z^3 - 2.0472e-159z^2}{z^4 - 0.5z^3 - 0.5z^2 - 3.4564e-11z - 4.1663e-11} \quad (30)$$

The noise model of the unit is:

$$G_{noisemodel} = \frac{z^4 + 0.0035537z^3 - 0.0011322z^2}{z^4 - 2.1078z^3 + 0.90396z^2 + 0.503z - 0.30002} \quad (31)$$

The predicted and noise model of the wavelet detection unit in this case is shown in Fig17.

6. Protection circuit

In the protection stage of the induction motor, there are many steps to perform exact or optimal protection of the circuit like: condition monitoring which is the process of monitoring a parameter of condition in machinery, such that a significant change is indicative of a developing failure. Many condition-monitoring methods, which monitor the motor's condition using only the currents and voltages of the motor, are preferred due to their low cost and non-intrusiveness (Zhang et al, 2011). For reliable operation of adjustable

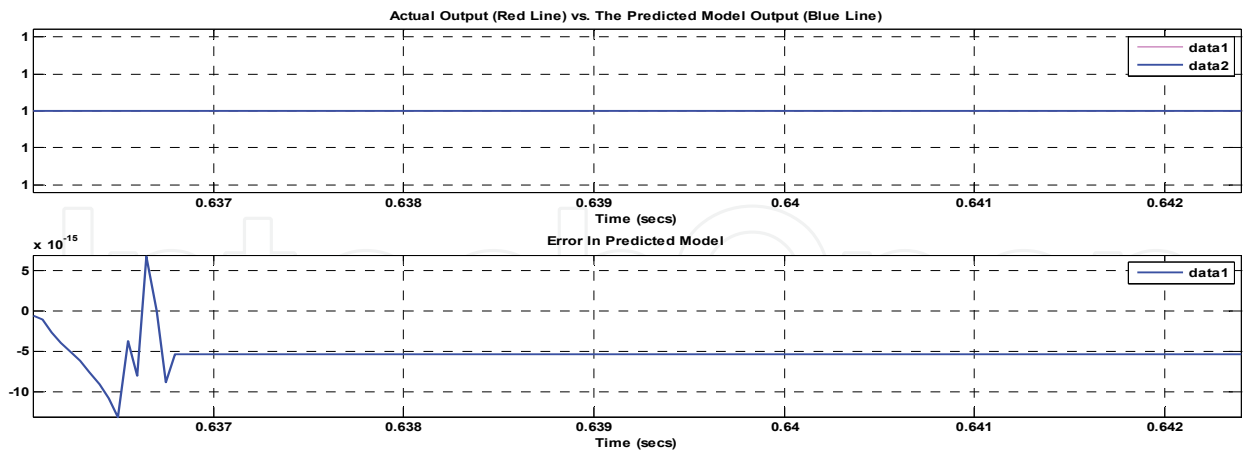

Fig. 17. Predicted model output and its noise model for wavelet detection unit in the broken rotor.

speed drive systems, the vulnerable components of the power converter, cable, and motor must be monitored, since failure of a single component can result in a forced outage of the entire system (Lee, et al, 2011).

In this chapter, two approaches are used to treat the faults mentioned above. First, voltage regulation with automatic gain control (AGC) is used to control the voltage after the occurrence of fault and hence the speed to maintain the operation of the induction motor as in (32):

$$AGC = reciprocal(mean(real(f_{vd})^2 + real(f_{vq})^2) \tag{32}$$

This is shown in Fig18:

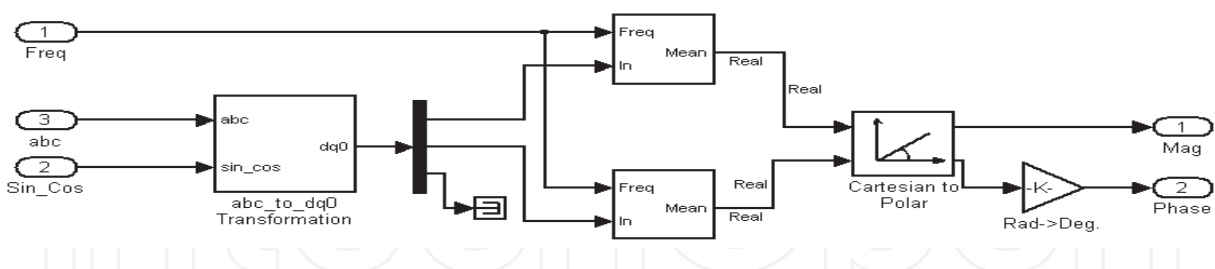

Fig. 18. Automatic gain controller circuit

The fault diagnosis condition depends also upon an optimization technique of induction motor flux as in (33).

$$\varphi_{optimal} = T_e * \sqrt{R_r / (3 / 2 * p)} \tag{33}$$

The proposed circuit of the wavelet fault diagnosis is shown in Fig10. The last stage of the protection is to stop the motor operation when the fault severity becomes high and cannot be controlled according to the following criteria.

$$\text{if } \max(I_q) > 180 \ \& \ \text{bad flux due to bad torque} \ \text{then stop the operation} \quad (34)$$

The protection circuit as in the Fig.19

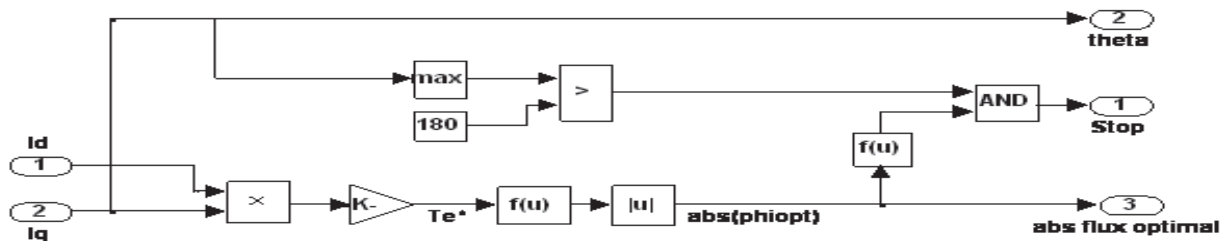

Fig. 19. Protection and checking of the optimal flux unit

Since this work focuses on the wavelet, the results of this stage are not included here. They are expected to be presented by the authors in a paper dealing with the protection of induction motors.

7. Simulation results

Computer simulations using Matlab/Simulink have been performed for assessment of operating features of the proposed scheme. The simulation involved a startup of an induction motor 0.5Hp, 230V, 50 Hz as is shown in Table 4. All pertinent mathematical models have been developed individually, using Simulink blocks for the power, electronic converters and the motor. The developed torque increases rapidly due to the slip speed, which is maximum at starting and decreases as the speed of the motor is increased. The classic vector control scheme consists of the torque and flux control loops. For the vector control of induction motors, the rotor field orientation has the advantage of easy decoupling of the torque and flux components of the controlled variable. The speed loop utilizes a PI controller to produce the quadrature axis currents which serves as the torque command ($K_p = 18$ and $K_i = 5$). Better PI tuning results in a better wavelet waveform. One phase of stator current is used as the input to the wavelet circuit. It is clear from Fig.11, Fig.12 and Fig.13 that detailed information is extracted from the high pass filter and approximation data from the low pass filter to show the exact location and time of the fault even for the transient response of the healthy case. A higher order of wavelet introduces better signal accuracy. Fig.14 shows the wavelet index with the threshold of the healthy case between 2.5 and 7. In this work, the stator short winding was high index (16.6), the range of this fault being 7-17 due to the severity of fault; the broken rotor bar was very light (0.12) and the range of this fault was between 0 and 0.2. The figure did not start from zero because there is a 1 sec delay for protection. Careful tuning of AGC is needed for the PID controller to get best results, in this work ($K_i = 100$, $K_p = 1$ and $K_d = 0$).

Fig.15, Fig.16 and Fig.17 show the outputs of the PEM (Predictive Error Method) estimator block which estimates linear input-output polynomial models in Simulink for the healthy case, stator short winding and broken rotor bar respectively. The monitoring of the optimal flux is another fault diagnosis indicator in this work which depends on both torque and rotor resistance as well as on the poles of the induction motor.

The last stage of the operation is the protection. Fig.19 shows the optimal flux and protection mechanism which depends on both torque, flux and on the phase of I_q . If this phase is more

than 180, this will lead to bad torque and flux and will indicate the need to stop the operation of induction motor.

8. Conclusion

The scalar control of induction motor drives have many drawbacks including slow response, unsuitable performance, torque ripple and impossibility of operation at all points of speed torque curve, vector control is implemented on an induction motor drive to solve these imperfections.

Three phase sinusoidal voltage is converted to dc voltage with the help of universal diode bridge rectifier. Current source inverters which dominate modern adjustable speed AC drives are not free from certain disadvantages.

In particular the high switching rate needed for good quality of the current fed to the motor cause's losses, electromagnetic interference etc. Accords to the results, the algorithm used is very effective and have been succeeded in maintain both speed and torque.

There are many conclusions can be included due to this work:

- The wavelet is considered as powerful tools in the fault detection and diagnosis of induction motors.
- Many wavelet classes can be generated by different kinds of mother wavelets and can be constructed by filters banks.
- The improvement of fault detection and diagnosis can be exploiting the wavelet properties to get high detection and diagnostics effectiveness.
- Theories of wavelet need to be pushed forward to insure best choosing of mother wavelet.
- The wavelet index can distinguish correctly between the faults and healthy induction motor.
- Matlab/Simulink axcellent package for both simulations and practicle experiments in the diagnostic of induction machines with wavelet.

9. References

- Abbas zadeh, K., Milimonfared, J., Haji, M., & Toliyat, H. (2001). Broken bar detection in induction motor via wavelet transformation. *The 27th Annual Conference of the IEEE Industrial Electronics Society*, Vol.1, pp. 95 -99.
- Ahmed Y. Ben Sasi, Fengshou Gu, Yuhua Li and Andrew D. Ball (2006). A validated model for the prediction of rotor bar failure in squirrel-cage motors using instantaneous angular speed. *Mechanical Systems and Signal Processing*, Vol.20, No 7, pp. 1572-1589.
- Hakan Calıs& Abdulkadir Cakır (2007). Rotor bar fault diagnosis in three phase induction motors by monitoring fluctuations of motor current zero crossing instants. *Electric Power Systems Research*, Vol.77, pp. 385-392.
- Andrew K.S. Jardine, Daming Lin, Dragan Banjevic (2006). A review on machinery diagnostics and prognostics implementing condition-based maintenance. *Mechanical Systems and Signal Processing*, Vol.20, pp.1483-1510.
- Anjaneyulu, N .Kalaiarasi and K.S.R (2007). Adaptive Vector Control of Induction Motor Drives. *International Journal of Electrical and Engineering*, Vol.1 .No.2, 239-245.

- Archana S. Nanoty, and A. R. Chudasama (2008). Vector Control of Multimotor Drive. *Proceedings of World Academy of Science, Engineering and Technology*, Vol.35, pp. 2070-3740.
- Ayaz, E., Ozturk, A., & Seker, S. (2006). Continuous Wavelet Transform for Bearing Damage Detection in Electric Motors. *IEEE Electrotechnical Conference, MELECON. Mediterranean*, pp. 1130 -1133.
- Bogalecka, Piotr Kołodziejek and Elz bieta (2009). Broken rotor bar impact on sensorless control of induction machine. *The International Journal for Computation and Mathematics in Electrical and Electronic Engineering*, Vol.28, No.3, pp.540-555.
- BPRA073. (1998). Field Orientated Control of 3-Phase AC-Motors. *Texas Instruments Europe*.
- C. Combastel, S. Leseq, S. Petropol, S. Gentil (2002). Model-based and wavelet approaches to induction motor on-line fault detection. *Control Engineering Practice*, Vol.10, No.5, pp.493-509.
- Cabal-Yepez, E., Osornio-Rios, R., Romero-Troncoso, R., Razo-Hernandez, J., & Lopez-Garcia, R. (2009). FPGA-Based Online Induction Motor Multiple-Fault Detection with Fused FFT and Wavelet Analysis. *International Conference on Reconfigurable Computing and FPGAs*, pp. 101 -106.
- Cao Zhitong, Chen Hongping, He Guoguang, Ritchie, E (2001). Rotor fault diagnosis of induction motor based on wavelet reconstruction" *Proceedings of the Fifth International Conference on Electrical Machines and Systems, ICEMS*, Vol.1, pp. 374 - 377.
- Chen, C.-M., & Loparo, K. (1998). Electric fault detection for vector-controlled induction motors using the discrete wavelet transform. *Proceedings of the American Control Conference*, Vol.6, pp. 3297 -3301.
- Cusido, J., Rosero, J., Cusido, M., Garcia, A., Ortega, J. L., & Author, Q. (2007). On-Line System for Fault Detection in Induction Machines based on Wavelet Convolution. *IEEE Conf. On Power Electronics Specialists, PESC*, pp. 927-932.
- Cusido, J., Rosero, J., Cusido, M., Garcia, A., Ortega, J., & Romeral, L. (2007). On-Line System for Fault Detection in Induction Machines Based on Wavelet Convolution. *IEEE Instrumentation and Measurement Technology Conference Proceedings, IMTC*, pp. 1 - 5.
- Cusido, J., Rosero, J., Ortega, J., Garcia, A., & Romeral, L. (2006). Induction Motor Fault Detection by using Wavelet decomposition on dq0 components. *IEEE International Symposium on Industrial Electronics*, Vol.3, pp. 2406 -2411.
- Cusido, J., Rosero, J., Romeral, L., Ortega, J., & Garcia, A. (2006). Fault Detection in Induction Machines by Using Power Spectral Density on the Wavelet Decompositions. *37th IEEE Conference on Power Electronics Specialists PESC*, pp. 1-6.
- Dimas Anton A, Syafaruddin, Dicky N Wardana, M.H.Purnomo, Takashi Hiyama (2010). Characterization of Temporary Short Circuit in Induction Motor Winding using Wavelet Analysis. *Proceedings of the International Conference on Modelling, Identification and Control*, pp. 477 -482.
- Douglas, H., & Pillay, P. (2005). The impact of wavelet selection on transient motor current signature analysis. *IEEE International Conference on Electric Machines and Drives*, pp. 80 - 85.

- Douglas, H., Pillay, P., & Ziarani, A. (2003). Detection of broken rotor bars in induction motors using wavelet analysis. *International IEEE Conf. On Electric Machines and Drive, IEMDC*, Vol.2, pp. 923 -928.
- Levent Eren and Michael J. Devaney (2004). Bearing Damage Detection via Wavelet Packet Decomposition of the Stator Current. *IEEE Transactions on Instrumentation and Measurement*, Vol.53, No.2, pp. 431-436.
- Faiz, J., Ebrahimi, B., Asaie, B., Rajabioun, R., & Toliyat, H. (2007). A criterion function for broken bar fault diagnosis in induction motor under load variation using wavelet transform. *International Conference on Electrical Machines and Systems, ICEMS*, pp. 1249 -1254.
- Gang Niu, Achmad Widodo, Jong-Duk Son, Bo-Suk Yang, Don-Ha Hwang, Dong, Sik Kang (2008). Decision level fusion based on wavelet decomposition for induction motor fault diagnosis using transient current signal. *Expert Systems with Applications*, Vol.35, pp.918-928.
- Hamidi, H., Nasiri, A., & Nasiri, F. (2004). Detection and isolation of mixed eccentricity in three phase induction motor via wavelet packet decomposition. *5th Asian Control Conference*, Vol.2, pp. 1371 -1376.
- J. Antonino-Daviu, M. Riera-Guasp, J. Roger-Folch, F.Martinez-Gimenez, A. Peris (2006). Application and optimization of the discrete wavelet transform for the detection of broken rotor bars in induction machines. *Applied and Computational Harmonic Analysis*, Vol.21, No.2, pp.268-279.
- J. Cusido, L. Romeral, J.A. Ortega, A. Garcia and J.R. Riba. (2010). Wavelet and PDD as fault detection techniques. *Electric Power Systems Research*, Vol.80, No.8, pp 915-924.
- J. Antonino-Daviu, P. Jover Rodriguez, M. Riera-Guasp, M. Pineda-Sanchez, A. Arkkio (2009). Detection combined faults in induction machines with stator parallel branches through the DWT of the startup current. *Mechanical Systems and Signal Processing*, Vol.23, pp.2336-2351.
- J.L. Silva Neto, Hoang Le-Huy (1996). Fuzzy Logic Based Controller for Induction Motor Drives. *IEEE, IECON*, pp. 631-634.
- Mohamed Boussak and Kamel Jarray (2006). A High Performance Sensorless Indirect Stator Flux Orientation Control of Induction Motor Drive. *IEEE trans. Industrial Electronics*, Vol. 53, pp. 41-49.
- Nirmesh Yadav, Sharad Sharma, Vikram M. Gadre, &ldquo (2004). Wavelet Analysis and Applications. *New Age International Publishers*, ISBN 81-224-1515-6.
- Khalaf Salloum Gaeid, Hew Wooi ping (2010). Diagnosis and Fault Tolerant Control of the Induction Motors Techniques: A review. *Australian Journal of Basic and Applied Sciences*, Vol.4 No.2, pp. 227-246.
- Khan, M., & Rahman, M. (2006). Discrete Wavelet Transform Based Detection of Disturbances in Induction Motors. *Electrical and Computer Engineering, ICECE*, pp. 462 -465.
- Kia, S., Heno, H., & Capolino, G.-A. (2009). Diagnosis of Broken-Bar Fault in Induction Machines Using Discrete Wavelet Transform without Slip Estimation. *IEEE Transactions on Industry Applications*, Vol.45, No.4, pp.1395 -1404.

- Lee, S. B.; Yang, J.; Hong, J.; Yoo, J.-Y.; Kim, B.; Lee, K.; Yun, J.; Kim, M.; Lee, K.-W.; Wiedenbrug, E. J.; Nandi, S. (2011). A New Strategy for Condition Monitoring of Adjustable Speed Induction Machine Drive Systems. *IEEE Transactions on Power Electronics*, Vol.26, No.2, pp.389 - 398.
- Liu, T., & Huang, J. (2005). A novel method for induction motors stator interturn short circuit fault diagnosis by Systems, *Proceedings of the Eighth International Conference on Electrical Machines and Systems, ICEMS*, Vol. 3, pp. 2254 - 2258.
- Lorand SZABO, JenőBarna DOBAI, Karoly Agoston BIRO (2005). Discrete Wavelet Transform Based Rotor Faults Detection Method for Induction Machines. *Intelligent Systems at the Service of Mankind*, Vol. 2, pp. 63-74.
- M. Riera-Guasp, J. Antonino-Daviua, J. Rusekb, J. Roger Folch (2009). Diagnosis of rotor asymmetries in induction motors based on the transient extraction of fault components using filtering techniques. *Electric Power Systems Research*, Vol.79, No.8, pp.1181-1191.
- M. Sabarimalai Manikandan, and S. Dandapat (2007). Wavelet energy based diagnostic distortion measure for ECG. *Biomedical Signal Processing and Control*, Vol.2, No.2, pp. 80-96.
- M. Sushama, G. Tulasi Ram Das and A. Jaya Laxmi (2009). Detection of High-Impedance Faults in Transmission. *ARNP Journal of Engineering and Applied Sciences*, Vol.4, No. 3, pp.6-12.
- Mohammed, O., Abed, N., & Ganu, S. (2006). Modelling and Characterization of Induction Motor Internal Faults Using Finite-Element and Discrete Wavelet Transforms. *IEEE Transactions on Magnetics*, Vol.42, No.10, pp.3434 -3436.
- Mohammed, O., Abed, N., & Garni, S. (2007). Modeling and characterization of induction motor internal faults using finite element and discrete wavelet transforms. *IEEE Symposium on Electric Ship Technologies, ESTS*, pp. 250 - 253.
- AN2388 Application Note, (2006). Sensor Field Oriented Control (IFOC) of Three-Phase AC Induction Motors Using ST10F276.
- Ordaz Moreno, A. de Jesus Romero-Troncoso, R. Vite-Frias (2008). Automatic Online Diagnosis Algorithm for Broken-Bar Detection on Induction Motors Based on Discrete Wavelet Transform for FPGA Implementation. *IEEE Transactions on Industrial Electronics*, Vol.55, No.5, pp.2193 -2202.
- Pineda-Sanchez, M., Riera-Guasp, M., Antonino-Daviu, J. A., Roger-Folch, J., Perez-Cruz, J., & Puche-Panadero, R. (2010). Diagnosis of Induction Motor Faults in the Fractional Fourier Domain. *IEEE Transactions on Instrumentation and Measurement*, Vol.59, No 8, pp.2065 - 2075.
- Ponci, F., Monti, A., Cristaldi, L., & Lazzaroni, M. (2007). Diagnostic of a Faulty Induction Motor Drive via Wavelet Decomposition. *IEEE Transactions on Instrumentation and Measurement*, Vol. 56 No.6, pp. 2606 -2615.
- Pons-Llinares, J., Antonino-Daviu, J., Riera-Guasp, M.-S. M., & Climente-Alarcon, V. (2009). Induction motor fault diagnosis based on analytic wavelet transform via Frequency B-Splines. *IEEE International Symposium on Diagnostics for Electric Machines, Power Electronics and Drives, SDEMPED*, pp. 1-7.

- R. Salehi Arashloo, A. Jalilian (2010). Design, Implementation and Comparison of Two Wavelet Based Methods for the Detection of Broken Rotor Bars in Three Phase Induction Motors. *1st Power Electronic & Drive Systems & Technologies Conference, PEDSTC*, pp. 345 –350.
- Riera-Guasp, M., Antonino-Daviu, J., Pineda-Sanchez, M., Puche-Panadero, R., & Perez-Cruz, J. (2008). A General Approach for the Transient Detection of Slip-Dependent Fault Components Based on the Discrete Wavelet Transform. *IEEE Transactions on Industrial Electronics*, Vol.55, No.12, pp.4167 –4180.
- S. Radhika, G.R. Sabareesh, G. Jagadanand, V. Sugumaran (2010). Precise wavelet for current signature in 3 ϕ IM. *Expert Systems with applications*, Vol.37, No.1, pp.450–455.
- Saleh, S., Khan, M., & Rahman, M. (2005). Application of a wavelet-based MRA for diagnosing disturbances in a three phase induction motor. *5th IEEE Conf. on Diagnostics for Electric Machines, Power Electronics and Drives, SDEMPED*, pp. 1-6.
- Samsi, R., Rajagopalan, V., & Ray, A. (2006). Wavelet-based symbolic analysis for detection of broken rotor bars in inverter-fed induction motors. *American Control Conference*, pp. 3032-3038.
- Sayed-Ahmed, A., Sizov, G., & Demerdash, N. (2007). Diagnosis of Inter-Turn Short Circuit for a Polyphase Induction Motor in Closed-Loop Vector-Controlled Drives. *IEEE ,42nd IAS Annual Meeting*, pp. 2262 – 2268.
- Supangat, R., Ertugrul, N. W., & Grieger, J. (2006). Detection of broken rotor bars in induction motor using starting-current analysis and effects of loading. *IEEE Proceedings on Electric Power Applications*, Vol.153:6, pp. 848 –855.
- Supangat, R., Grieger, J., Ertugrul, N., Soong, W., Gray, D., & Hansen, C. (2007). Detection of Broken Rotor Bar Faults and Effects of Loading in Induction Motors during Rundown. *IEEE International Conference on Electric Machines & Drives, IEMDC*, Vol.1, pp. 196 – 201.
- Turkmenoglu, M. A. (2010). Wavelet-based switching faults detection in. *IET Science, Measurement and Technology*, Vol.4, No.6, pp.303–310.
- Yang, C., Cui, G., Wei, Y., & Wang, Y. (2007). Fault Diagnosis for Induction Motors Using the Wavelet Ridge. *Second International Conference on Bio-Inspired Computing: Theories and Applications, BIC-TA*, pp. 231 – 235.
- Yasser Gritli, Andrea Stefani, Claudio Rossi, Fiorenzo Filippetti and Abderrazak Chatt (2011). Experimental validation of doubly fed induction machine electrical faults diagnosis under time-varying conditions. *Electric Power Systems Research*, Vol.81, No.3, pp.751-766.
- Zhang Jian wen, Zhu Ning-hui, Yang Li, Yao Qi, Lu Qing (2007). A Fault Diagnosis Approach for Broken Rotor Bars Based on EMD and Envelope Analysis. *Journal of China University Mining & Technology*, Vol.17, No. 2, pp.205-209.
- Zhang, Pinjia; Du, Yi; Habetler, T.G.; Lu, Bin (2011). A Survey of Condition Monitoring and Protection Methods for Medium-Voltage Induction Motors. *IEEE Transactions on Industry Applications*, Vol.47, No.1, pp.34 - 46.

Pons-Llinares, J.; Antonino-Daviu, J.; Roger-Folch, J.; Morinigo-Sotelo, D.; Duque-Perez, O.; (2010). Eccentricity Diagnosis in Inverter Fed Induction Motors via the Analytic Wavelet Transform of Transient Currents. *XIX International Conference on Electrical Machines (ICEM)*, pp.1 -6.

IntechOpen

IntechOpen



MATLAB for Engineers - Applications in Control, Electrical Engineering, IT and Robotics

Edited by Dr. Karel Perutka

ISBN 978-953-307-914-1

Hard cover, 512 pages

Publisher InTech

Published online 13, October, 2011

Published in print edition October, 2011

The book presents several approaches in the key areas of practice for which the MATLAB software package was used. Topics covered include applications for: -Motors -Power systems -Robots -Vehicles The rapid development of technology impacts all areas. Authors of the book chapters, who are experts in their field, present interesting solutions of their work. The book will familiarize the readers with the solutions and enable the readers to enlarge them by their own research. It will be of great interest to control and electrical engineers and students in the fields of research the book covers.

How to reference

In order to correctly reference this scholarly work, feel free to copy and paste the following:

Khalaf Salloum Gaeid and Hew Wooi Ping (2011). Wavelet Fault Diagnosis of Induction Motor, MATLAB for Engineers - Applications in Control, Electrical Engineering, IT and Robotics, Dr. Karel Perutka (Ed.), ISBN: 978-953-307-914-1, InTech, Available from: <http://www.intechopen.com/books/matlab-for-engineers-applications-in-control-electrical-engineering-it-and-robotics/wavelet-fault-diagnosis-of-induction-motor>

INTECH
open science | open minds

InTech Europe

University Campus STeP Ri
Slavka Krautzeka 83/A
51000 Rijeka, Croatia
Phone: +385 (51) 770 447
Fax: +385 (51) 686 166
www.intechopen.com

InTech China

Unit 405, Office Block, Hotel Equatorial Shanghai
No.65, Yan An Road (West), Shanghai, 200040, China
中国上海市延安西路65号上海国际贵都大饭店办公楼405单元
Phone: +86-21-62489820
Fax: +86-21-62489821

© 2011 The Author(s). Licensee IntechOpen. This is an open access article distributed under the terms of the [Creative Commons Attribution 3.0 License](#), which permits unrestricted use, distribution, and reproduction in any medium, provided the original work is properly cited.

IntechOpen

IntechOpen