

# We are IntechOpen, the world's leading publisher of Open Access books Built by scientists, for scientists

**4,800**

Open access books available

**122,000**

International authors and editors

**135M**

Downloads

Our authors are among the

**154**

Countries delivered to

**TOP 1%**

most cited scientists

**12.2%**

Contributors from top 500 universities



**WEB OF SCIENCE™**

Selection of our books indexed in the Book Citation Index  
in Web of Science™ Core Collection (BKCI)

Interested in publishing with us?  
Contact [book.department@intechopen.com](mailto:book.department@intechopen.com)

Numbers displayed above are based on latest data collected.

For more information visit [www.intechopen.com](http://www.intechopen.com)



## Pesticide Biomarkers in Terrestrial Invertebrates

Juan C. Sanchez-Hernandez

*Laboratory of Ecotoxicology, Faculty of Environmental Science and Biochemistry,  
University of Castilla-La Mancha,  
Spain*

### 1. Introduction

Nowadays it is widely accepted that current agricultural practices cause a loss of biodiversity (Bianchi et al., 2006). Moreover, the introduction of vast areas of monocultives (e.g., biofuel crops) contributes to increase the risk for crop loss by pest infestation (Landis et al., 2008). Despite the introduction of integrated pest management (IPM) strategies in an attempt to reduce pesticide inputs, chemical control is still necessary to combat pests (Devine & Furlong, 2007). As an example, the figure 1 shows the evolution of pesticide

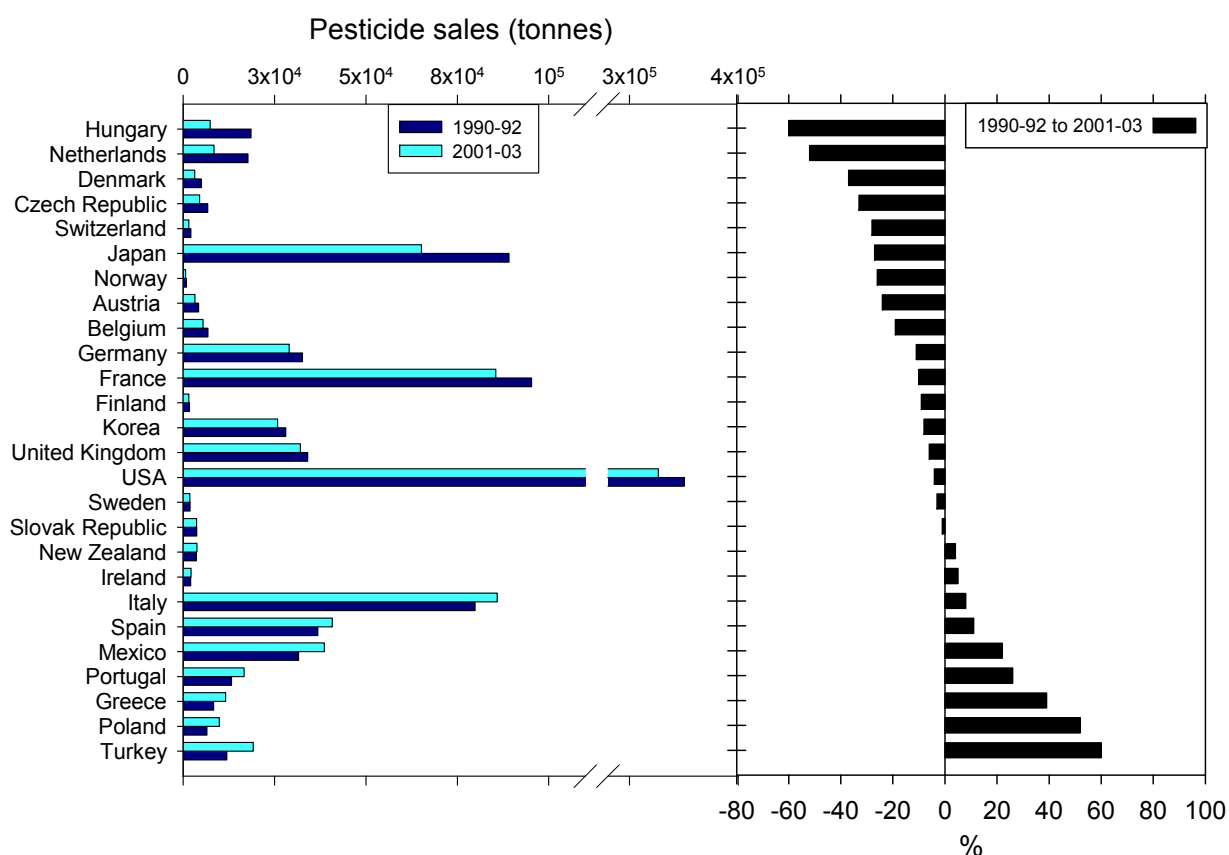

Fig. 1. Pesticide consumption worldwide. Data taken from OECD 2009 (<http://dx.doi.org/10.1787/286683827028>).

consumption in the last decade. Some European Union (EU) member states have experienced a notable increase (>20%) of pesticide use (OECD 2009). According to Eurostat (2007), five EU member states (France, Spain, Germany, Italy and the United Kingdom) account for the nearly 75% of the total plant protection products (PPPs) consumed in the EU. In the particular case of insecticides, Italy and Spain represented the 33% and 29%, respectively, of the insecticide consumption in 2003 (Eurostat, 2007). The organophosphate (OP) and, in a less extent, the carbamate (CM) insecticides are the most used chemical classes of PPPs in the EU (Fig. 2). Chlorpyrifos, parathion-methyl, dimethoate, imidacloprid, methomyl, fenthion, methiocarb, methidathion, chlorpyrifos-methyl and endosulfan represent the top-10 active substances in the European PPP market (Eurostat, 2007). Beside insecticides, OP and CM compounds are also present in the formulation of herbicides (21,722 and 2,144 tonnes of OP and thiocarbamate herbicides, respectively, in 2003) and fungicides (21,149 and 3,466 tonnes of dithiocarbamate and OP fungicides, respectively, in 2003) (Eurostat, 2007). Taken together, these data show that OP and CM agrochemicals are still two important groups of pesticides in the current agriculture despite the progressive increase in the use of synthetic pyrethroids (SPTs), among other new pesticide classes. Although data in figure 1 show a generalized global tendency in reducing the pesticide consumption, it does not seem the same scenario in emerging countries like India (Abhilash & Singh, 2009).

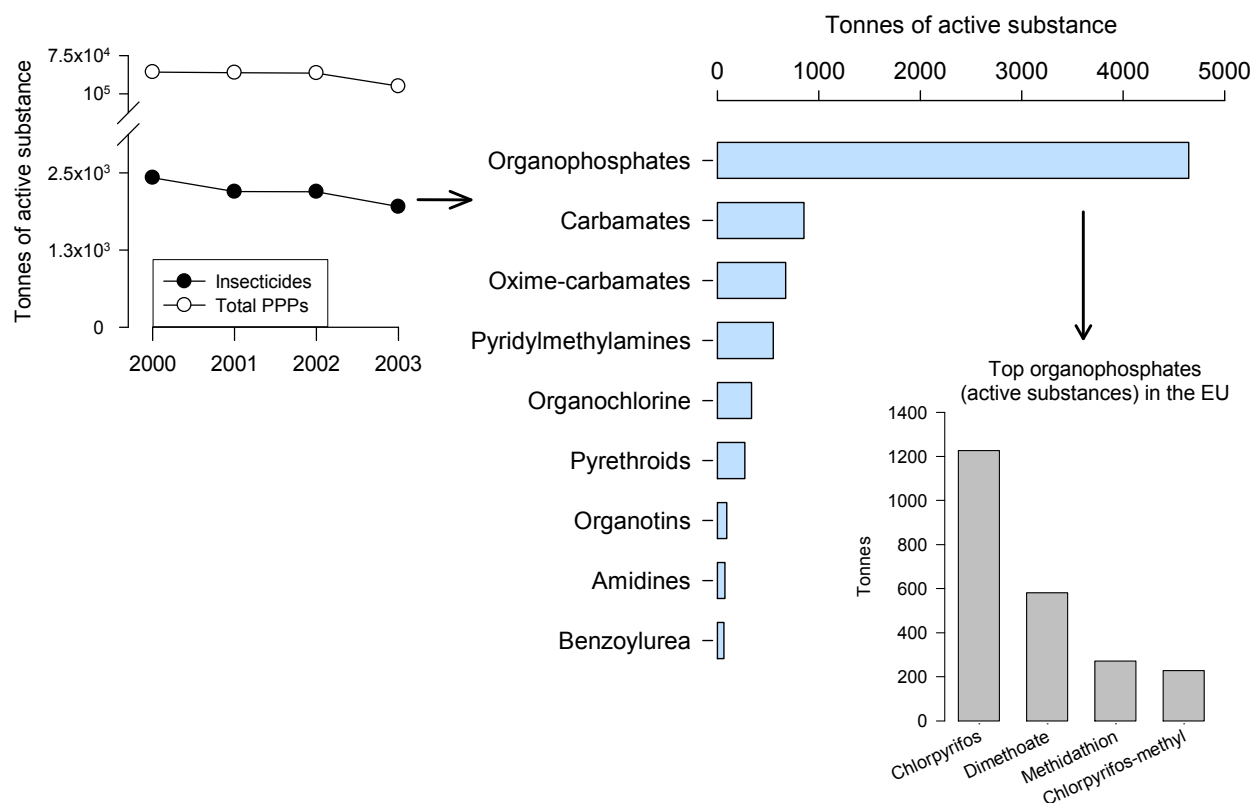

Fig. 2. Use of plant protection products (PPPs) and, particularly, insecticides in the European Union (EU) between 2000 and 2003. Horizontal bar chart shows the main chemical classes of insecticides used in the EU, whereas vertical bar chart shows the most used insecticide active substances (reference year 2003). Data taken from the Eurostat (2007).

Therefore, it would seem evident that pesticide consumption will not decrease substantially and globally in the next decade. Under this assumption, exposure and effect assessment of pesticides in the environment would be necessary for decision-making related to pesticide use and agroecosystem protection, even in a post-authorization phase.

### **1.1 Why soil is an environmental compartment of (eco)toxicological concern?**

The Soil Science Society of America defines soil quality as the “capacity of a specific kind of soil to function, within natural or managed ecosystem boundaries, to sustain plant and animal productivity, maintain or enhance water and air quality, and support human health and habitation” (Karlen et al., 1997). Therefore, soil degradation is the situation by which soil loses its agronomic and environmental qualities. Both natural phenomena and human activities cause soil degradation. For example, the EU has identified up to eight primary threats for soil quality: erosion, decline in organic matter, contamination, salinisation, compaction, loss of biodiversity, soil sealing, landslides and flooding (European Commission, 2002). Among these soil-deteriorating processes, contamination is probably the most important and dangerous phenomenon to humans because soil is a vital natural resource and, in turn, the man is a significant vector to soil contamination.

Transport of hazardous chemicals, agricultural pesticide applications, oil and fuel dumping, and discharge of industrial/urban wastes are the main human activities causing soil contamination (Mirsal, 2008). Moreover, soil is the environmental compartment where most of the pollutants released into the biosphere are accumulated (Köhne et al., 2009). Once in soil, a wide variety of physicochemical and biological processes, shown in the figure 3A, contribute jointly to the environmental transport and fate of contaminants (Cáceres et al., 2010). Soil acts therefore as a “filter” or “reactor” reducing pollutant leaching towards groundwater or leakage into atmosphere. However, soil contaminants represent a serious hazard to organisms living in both belowground and aboveground systems. The scientific literature is plenty of examples that illustrate the negative impact of agrochemicals on wildlife (Devine & Furlong, 2007; Newman et al., 2006). Agrochemicals take part in the population decline of amphibians (e.g., Mann et al., 2009) and pollinators (e.g., Potts et al., 2010; Spivak et al., 2011). Likewise, pesticides cause side-effects on natural populations of pest enemies (Devine & Furlong, 2007; Devotto et al., 2007) which can make the IPM strategies ineffective. Moreover, reduction of prey populations as a consequence of pesticide applications can lead to indirect effects on top predators (Flavia et al., 2010; Fleeger et al., 2003). Soil microorganisms are also affected by pesticide applications. For example, one of the main metabolites of the OP chlorpyrifos, i.e., 3,5,6-trichloro-2-pyridinol, displays antimicrobial properties. This metabolite inhibits the proliferation of soil microorganisms and, therefore, the subsequent metabolism of chlorpyrifos is reduced (Racke, 1993). The impact of agrochemicals on soil microorganisms can result in changes in the soil nutrient cycles and in the failure of microorganism-assisted bioremediation actions (Barker & Bryson, 2002; Gianfreda & Rao, 2008). Soil enzymes are another molecular target of pesticide inputs. Most of the soil enzyme activities are considered the direct expression of microorganism communities involved in nutrient cycles and they are therefore an indicator of soil fertility (e.g., Gianfreda & Rao, 2008). Many investigations have documented the effects of agrochemicals such as triazines, OPs or CMs on soil enzyme activities (reviewed in Gianfreda & Rao, 2008). Taken together, these studies suggest that control of pesticide residues in soil should be a priority strategy in those agroecosystems where pesticides are intensively used.

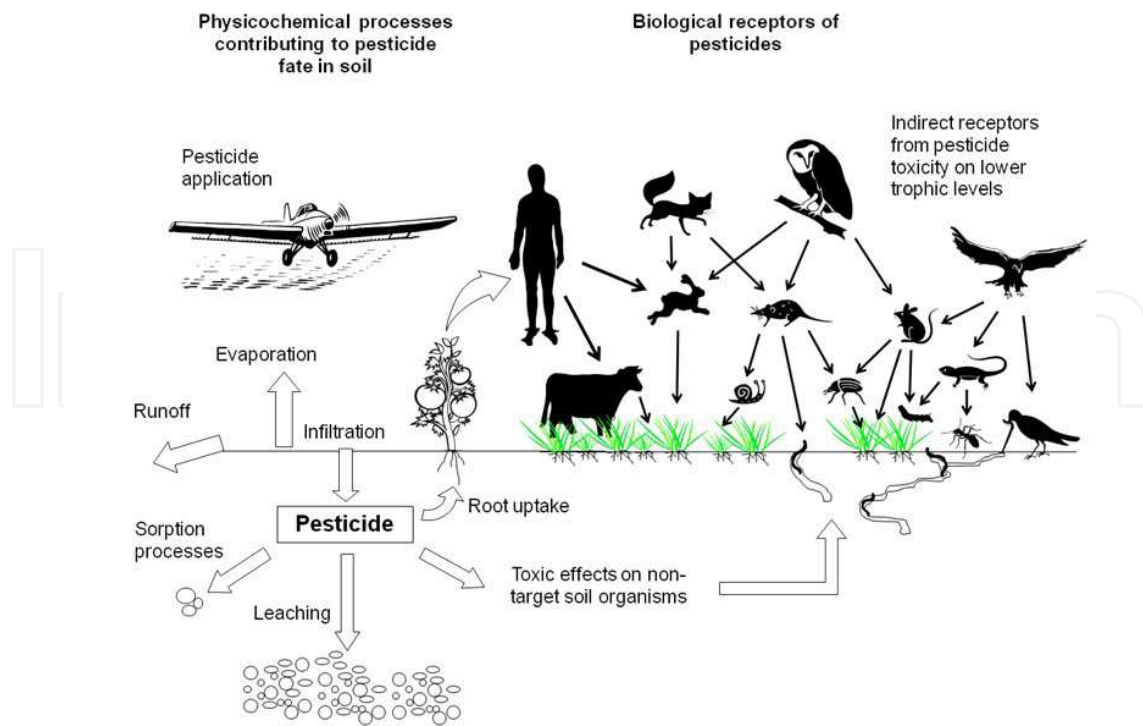

A)

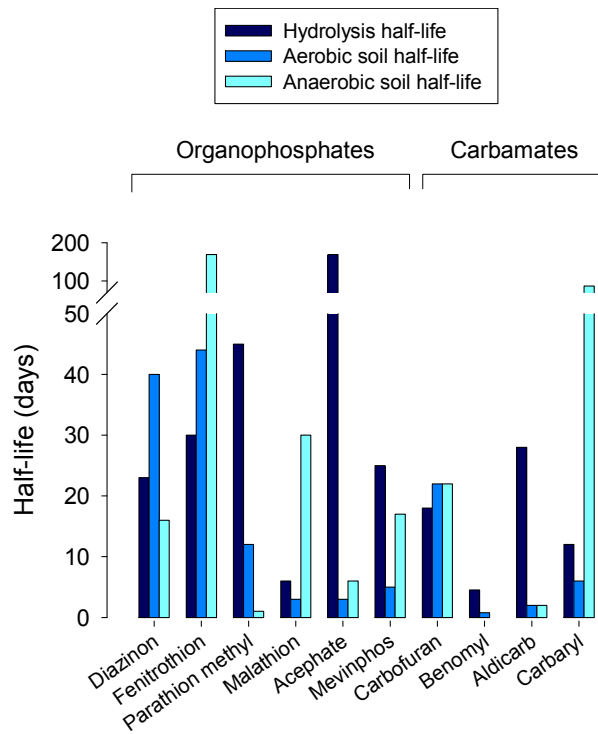

B)

Fig. 3. A) Main physicochemical and biological processes contributing to pesticide fate and toxicity (conceptual scheme elaborated from Köhne et al. (2009). B) Hydrolysis and soil (under aerobic and anaerobic conditions) half-lives of selected organophosphate and carbamate insecticides. Data taken from the Pesticide Action Network (PAN)-Pesticide Database ([www.pesticideinfo.org](http://www.pesticideinfo.org)) and from Cáceres et al. (2010).

## 1.2 Why invertebrate biomarkers can be useful in the assessment of soil pollution by pesticides?

In environmental toxicology, biomarkers are defined as molecular, biochemical, physiological or histological indicators of contaminant exposure or effects (van Gestel & van Brummelen, 1996). This definition frequently includes behavioral changes (e.g., Walker et al., 2001). Biomarkers have shown their ecotoxicological role as indirect measurements of bioavailability or toxicant's absorption when used in toxicity testing (Lanno et al., 2004), or as key elements in the understanding of the toxic mechanism underlying observed effects at whole-organism level (Forbes et al., 2006). They have also been useful to distinguish acute toxicity from long-term effects (Hagger et al., 2009).

Nowadays, there is an intense debate on the suitability and meaning of biomarkers in the environmental risk assessment of environmental contaminants. Traditionally, biomarkers tried to be early indicators of adverse effects at population or community levels (e.g., Peakall, 1992). In addition, a battery of biomarkers covering multiple levels of biological organization is recommended to distinguish reversible adaptive responses from irreversible toxic effects (Galloway et al., 2004; Gastaldi et al., 2007). However, the use of biomarkers for making ecologically relevant predictions is questioned (e.g., Chapman, 2002; Forbes et al., 2006). But, most of the researchers agree that biomarkers provide evidences on the molecular mechanisms operating to cause observed toxic effects on the whole individual.

Biomarker research has had an increasing development in aquatic toxicology. A survey of the scientific literature for biomarker studies indicates that its use has been scarcely investigated with terrestrial organisms, particularly invertebrates. The figure 4 is an attempt to illustrate this marked difference in the impact of biomarker research in terrestrial organisms. We searched the biomarker literature focused on ecotoxicological investigations involving the aquatic and terrestrial systems in the past 10 years using the *ISI Web of Knowledge* search engine. We filtered the searching with multiple keywords specific to aquatic and terrestrial systems. It is evident that the difference in the number of publications between biomarker studies involving the aquatic ecosystem and those performed in the terrestrial system increases progressively since 2000. Moreover, when we limited the searching to 'invertebrates' and 'pesticides', the number of studies addressed on biomarkers increased for aquatic invertebrates, whereas their use in terrestrial invertebrates seems merely anecdotic.

From the literature survey showed in the figure 4, the pertinent question is why biomarkers have not had a similar concern for terrestrial invertebrates if we consider that soil is the primary environmental media where pesticide are accumulated and transformed. Furthermore, pesticides such as OPs, CMs or SPTs generally display short half-lives (from days to a few months) in the environment, and high concentrations of pesticides (and their metabolites) in water are not the most frequent scenario (Cáceres et al., 2010; Gavrilescu, 2005; Katagi, 2004). Agrochemicals can reach the aquatic systems by direct application, runoff from pesticide-treated fields or wind-borne drift (Fig. 3A). However, the figure 3B shows that persistence of OP and CM pesticides in soil seems lower than that observed in water, although it is shown the water half-lives by hydrolysis solely and other degradation processes (photolysis or microbial breakdown) are not considered (Fig. 3B). Because agricultural pesticides are not intended to be used in water bodies and the persistence of pesticides in soil is relatively low, concentrations of agrochemicals in water systems would be assumed as very low otherwise intentional applications into water take place. One possible explanation to the limited studies on pesticide biomarkers in soil invertebrates



could be the heterogeneous and complex nature of the terrestrial environment that makes difficult to identify harmful effects on biota from pesticide exposure. Moreover, economic aspects could also account for a high research interest in aquatic invertebrate. Nevertheless, terrestrial invertebrates are key components of the soil system. For example, earthworms are considered soil engineers with a notable contribution to soil function and structure (Lavelle et al., 2004) as well as to plant growth and health (Scheu, 2003). Other terrestrial invertebrates such as honey bees or the natural enemies of pests play an unquestionable pivotal function in the agroecosystem.

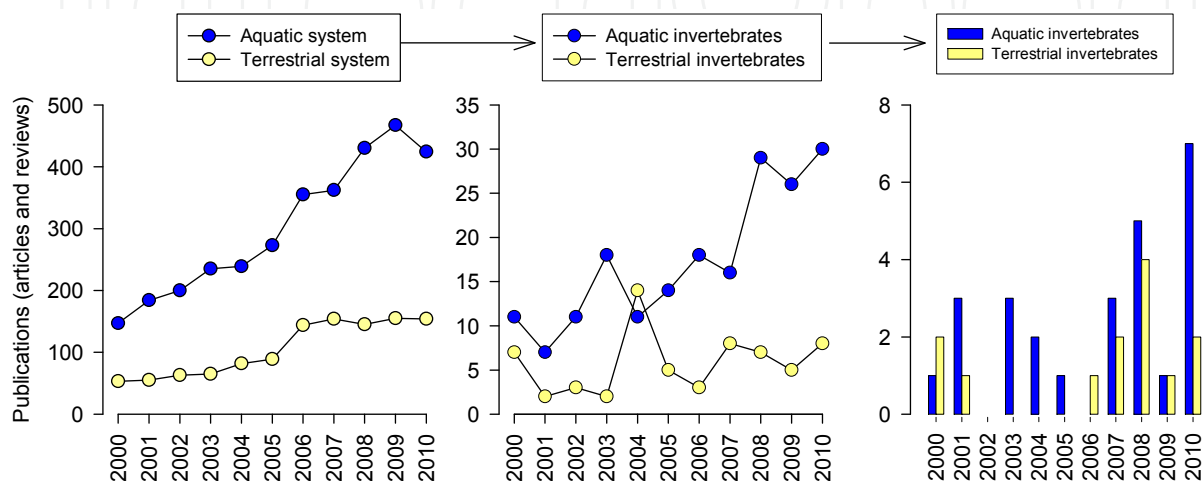

Fig. 4. Number of annual publications (limited to articles and reviews) involving biomarkers. Left graph shows the evolution of biomarker studies in the aquatic and terrestrial ecosystem. Centre graph shows those investigations limited to aquatic and terrestrial invertebrates, whereas the right graph illustrates the biomarker research in these groups of organisms when agrochemicals were the chemical stress. Searching was made using the ISI Web of Knowledge bibliographic search engine ([www.accesowok.fecyt.es/login/](http://www.accesowok.fecyt.es/login/)).

To the question why biomarkers can be useful in the assessment of pesticide toxicity, we could find an answer in their valuable use in the understanding of the mechanistic basis of pesticide toxicity in non-mammal species. Most of the interpretations and conclusions drawn from biomarker responses measured in invertebrates are provided on the basis of the biomarker knowledge in mammals. However, the physiology and biochemistry of many terrestrial invertebrates are not well known, in particular those species that have not an economic or recreational interest. This is not the case of some pest species. For example, it is well known that carboxylesterases play a significant role in the mechanism of pesticide tolerance and resistance in the pest species (Hemingway et al., 2004; Oakeshott et al., 2005). These esterases modulate the toxicity of OPs, CMs and SPTs through or hydrolysis reactions with this agrochemicals (Wheelock et al., 2008). These chemico-biological interactions between esterases and pesticides have not been extensively investigated in non-target terrestrial invertebrates.

This chapter examines the current knowledge on biomarkers of pesticide exposure and effects in terrestrial invertebrates. Particular emphasis will be put in earthworms because of their ecological, toxicological and agronomic concern. Comparisons with related studies performed with aquatic organisms are unavoidable, and will enable us to know at what

extend the findings with aquatic organism biomarkers have been reproduced in soil organisms. Finally, we suggest some issues of methodological concern when biomarkers are used for monitoring pesticide effects or to provide mechanistic understandings on the toxic effects observed at the whole-organism level.

## 2. Biomarkers of pesticide exposure and effect

### 2.1 Cholinesterases and carboxylesterases

Esterases act on the ester bond. According to the International Union of Biochemistry they are included in the subgroup 3.1 of hydrolases. In environmental toxicology, acetylcholinesterases (AChE, EC 3.1.1.7), butyrylcholinesterases (BChE, EC 3.1.1.8) and carboxylesterases (CbE, EC 3.1.1.1) have had particular attention because of their role in pesticide toxicity and detoxification. The inhibition of AChE activity is the most used biomarker in the field monitoring of OP and CM impact. This is not surprising because the primary mechanism of acute toxicity of these agrochemicals is the inhibition of AChE activity at the nervous tissue (Thompson & Richardson, 2004). Some reviews provide a comprehensive analysis of this biomarker in the aquatic system (e.g., Domingues et al., 2010; Fulton & Key, 2001; Hyne & Maher, 2003; Jemec et al., 2009; Monserrat et al., 2007; Sanchez-Hernandez, 2001). Carbamate and OP pesticides interact with ChEs, and CbEs in a very similar way (Fig. 5). The carbonyl group of the CM reacts with the serine hydroxyl group at the active site of the esterase to yield a Michaelis-type complex. The carbamylated enzyme is unstable and the activity is rapidly reversed in the presence of water. In this reaction, the CM is chemically destroyed to form

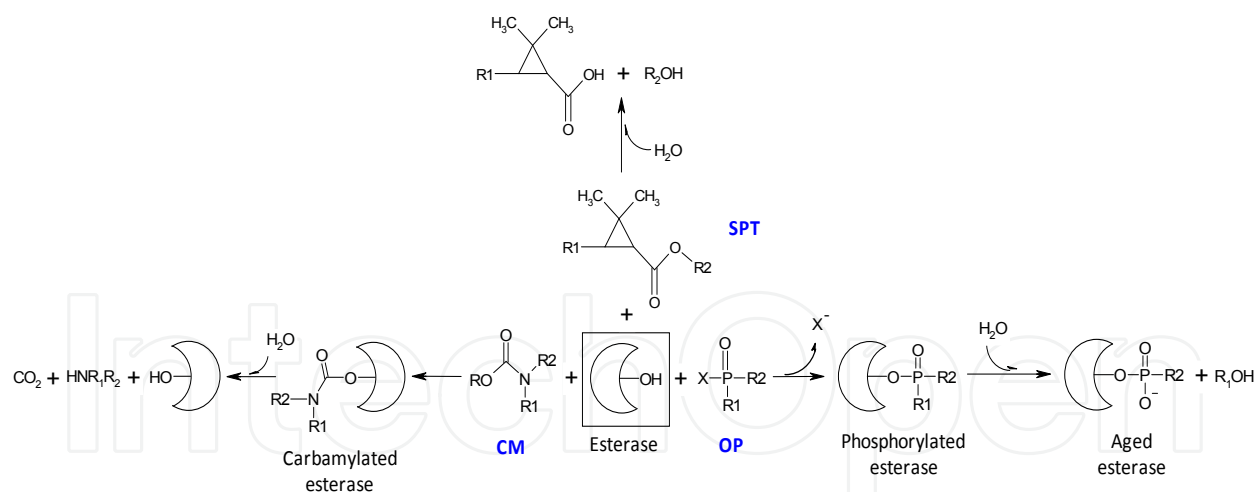

Fig. 5. Interactions of esterases (cholinesterases and carboxylesterases) with carbamates (CM), the oxon metabolites of organophosphates (OP) and synthetic pyrethroids (SPT). Inhibition of esterases by CMs yields a carbamylated complex which is unstable and the esterase activity is rapidly recovered in the presence of water. Organophosphates inhibit irreversibly the hydrolysis activity of ChEs and CbEs by the formation of a stable phosphorylated complex. Under this condition, restoration of the esterase activity requires the synthesis of new enzyme. Synthetic pyrethroids interact only with CbEs, and these esterases hydrolyze them to yield the corresponding alcohol and carboxylic acid. Scheme elaborated from Sogorb & Vilanova (2002) and Thompson & Richardson (2004).



CO<sub>2</sub> and an amine (Sogorb & Vilanova, 2002; Thompson & Richardson, 2004). Similarly, the phosphoryl moiety of the OPs reacts with the serine hydroxyl group of ChEs, or CbEs, to form a stable complex. At this point, the phosphorylated enzyme can undergo three main pathways: spontaneous reactivation, oxime-induced reactivation, or aging. Spontaneous reactivation occurs in the presence of water but it is a very slow reaction, and the enzyme does not recover its full normal activity. Chemical-induced reactivation employing oximes is a faster mechanism of activity restoration. Oximes are nucleophilic reagents able to attack the phosphoryl group bound to the active site of the esterase resulting in the recovery of the activity (Thompson & Richardson, 2004). If the enzyme remains long time inhibited, one alkyl group can release from the phosphyl-esterase complex (dealkylation) and leads the enzyme to a permanent inactivation, a situation known as aging (Fig. 5). At this stage, the esterase cannot be reactivated either spontaneously or using oximes. The type of esterase and the chemical nature of the inhibitor are determinants in the pathway that the phosphorylated enzyme will follow. These post-inhibitor pathways indirectly modulate the toxicity of the OP compound or even may contribute to the chemical interactions between pesticides (e.g., synergism and antagonism). In the case of SPTs, CbEs hydrolyze these agrochemicals to yield the corresponding alcohol and carboxylic acid (Fig. 5).

Cholinesterases and CbEs have been extensively investigated in many pest species because of their implications in pesticide resistance (Hemingway et al., 2004; Oakeshott et al., 2005). Conversely, little is known about these esterases in terrestrial invertebrates of ecological concern such as earthworms or pollinator species. Most of the available works with non-target invertebrate esterases are focused on enzymological aspects of these hydrolases. Laboratory studies have been aimed to examine three main features commonly associated to a good biochemical biomarker: 1) *in vitro* sensitivity to OP and CB insecticides, 2) recovery of ChE activity following pesticide exposure and 3) relationship between esterase inhibition and observed adverse effects at whole-individual level (e.g., growth, mortality or behavior changes).

Earthworms have been model organisms in these esterase investigations. Enzymological characterization of earthworm ChE activity has been extensively investigated in the past (Stenersen, 1980), and more recently, some laboratory studies have suggested the inclusion of CbE activity in the assessment of pesticide exposure and toxicity in these soil organisms (Collange et al., 2010; Sanchez-Hernandez & Wheelock, 2009). Many authors postulate that sensitivity of CbE activity to both OP and CM insecticides modulates the acute toxicity of these agrochemicals. The stoichiometric binding between CbEs and the insecticide (see Fig. 5) can lead to a reduction in the number of inhibitor molecules able to interact with nervous AChE. This assumption has led to compare the sensitivity of ChE and CbE activities to model OP and CM insecticides. Thus, CbE activity of aquatic organisms generally displays a higher *in vitro* and *in vivo* sensitivity to OPs than ChE activity (e.g. Barata et al., 2004; Kuster, 2005; Wogram et al., 2001). These observations are also reproduced in some terrestrial invertebrate groups. For example, earthworms exposed to chlorpyrifos-spiked soils showed a higher percentage of CbE inhibition than ChE activity, irrespective of the tissue used for esterase measurements (Collange et al., 2010; González Vejares et al., 2010). However, foot CbE activity in juvenile garden snails (*Helix aspersa*) was less sensitive to inhibition by dimethoate than foot AChE activity (Coourdassier et al., 2002). It was suggested in this latter study that the lower sensitivity of foot CbE to the OP could mean a reduced ability of CbEs to protect AChE activity against OP inhibition. Similar results were observed by Laguerre et al. (2009) in the

terrestrial snail *Xeropicta derbentina*. They reported an IC<sub>50</sub> (the concentration of pesticide causing a 50% reduction in the enzyme activity) value of  $3.8 \times 10^{-8}$  M for AChE activity against chlorpyrifos-oxon, whereas the IC<sub>50</sub> was  $3.2 \times 10^{-6}$  M for CbE activity. However, when dichlorvos was the inhibitor, the degree of CbE inhibition was stronger than that of AChE (Laguerre et al., 2009).

In general, phosphorylated ChE and CbE activities in earthworms and snails display an extremely slow recovery rate (Coourdassier et al. 2001, Rault et al. 2008, Collange et al. 2010). This limited capacity of returning to normal activity levels following OP exposure is a generalized phenomenon in earthworms (Table 1). Synthesis of new enzyme would be the most plausible explanation for this slow recovery of OP-inhibited esterase activity. Although spontaneous reactivation of the inhibited enzyme could also contribute to full recovery of the esterase activity, this is not true when the inhibitor is an OP compound (Rodríguez-Castellanos & Sanchez-Hernandez, 2007). A slow recovery rate enables to detect the OP exposure over a longer period of time after OP applications. This is a desirable feature for assessing anti-ChE exposure because of most of these pesticides show a low persistence in the environment (Fig. 3B).

Species	Biological material	Insecticide (concentration)	Time of exposure	Cholinesterase response	Reference
<i>Eisenia fetida</i>	Whole body	Chlorpyrifos (240 mg/kg dry wt)	2 days	No recovery of E2 (a carbaryl-resistant form of ChE) activity during 84 days of transferring earthworms to clean soil. E1 (a carbaryl-sensitive form of ChE) recovered its normal level of activity after 21 days followed OP exposure.	(Aamodt et al., 2007)
<i>Aporrectodea caliginosa</i> and <i>Allolobophora chlorotica</i>	Whole body	Parathion-ethyl (1 and 10 mg/kg dry wt)	14 days	No recovery of ChE activity of <i>A. caliginosa</i> exposed to both OP concentrations after 70 days of transferring earthworms to clean soil. Full recovery of ChE activity in <i>A. chlorotica</i> exposed	(Rault et al., 2008)

				to 1 mg kg <sup>-1</sup> after 70 days of transferring earthworms to clean soil, but no recovery of ChE activity in the group exposed to 10 mg/kg.	
<i>A. caliginosa</i>	Whole body	Diazinon (60 mg/kg dry wt). Chlorpyrifos (28 mg/kg dry wt)	14 days	No recovery of ChE activity during the 14 days of OP exposure (inhibition percent > 85 %).	(Booth et al., 2000)
<i>Lumbricus terrestris</i>	Body wall muscle	Chlorpyrifos (3, 12 and 48 mg/kg)	2 days	No recovery of muscle ChE activity of <i>L. terrestris</i> exposed to 12 and 48 mg/kg dry wt after 35 days of transferring earthworms to clean soil.	(Collange et al., 2010)
<i>L. terrestris</i>	Pharynx, crop, gizzard, foregut and seminal vesicles	Chlorpyrifos (3, 12 and 48 mg/kg)	2 days	Carboxylesterase activity of gut tissues (measured with the substrate 4-NPV) did not recover its activity in earthworms exposed to 12 and 48 mg/kg.	(González Vejares et al., 2010)

Table 1. Recovery of cholinesterase (ChE) activity in several adult earthworm species following exposure to organophosphorus (OP)-spiked soils. This table was elaborated from data published as supplementary material in Collange et al. (2010).

One of the most desirable attribute of a biomarker when it is used in the environmental assessment of contaminants is to be a predictor of adverse effects at higher levels of biological organization (e.g., whole individual or population). However, many researchers have shown that such a link is hard to establish (Chapman, 2002; Forbes et al., 2006). In the cascade of biological responses occurring when the organism is exposed to environmental contaminants, it is expected that early responses occur at biochemical and molecular levels before than observed effects at higher level (changes in growth, reproduction or behavior). However, biological responses at the whole-individual level are often more sensitive or more easily detectable than biochemical biomarkers. For example, burrowing activity of earthworms was

a more sensitive endpoint to imidacloprid than ChE and GST activities (Capowiez et al., 2003). Comparisons of LOEC (lowest observed effect concentration) values between biochemical biomarkers and whole-organism responses measured in the terrestrial isopod *Porcellio scaber* evidenced that the biochemical biomarkers were not necessarily more sensitive to diazinon or imidacloprid exposures (Jemec et al., 2009). To a less extent, inhibition of ChE activity by pesticides has been related to tissue damage. The carbamate insecticides methomyl and methiocarb caused histopathological and ultrastructural alterations in the nervous tissue of the land snail *Eobania vermiculata* after 14 d of exposure to sublethal concentrations of these CMs (Essawy et al., 2008).

The interaction between ChE activity and pesticides has been explored with terrestrial non-target organisms other than earthworms and snails. Some studies have involved the use of ChE inhibition as an indicator of pesticide exposure in bees, isopods or spiders. Recently, there is a global concern in population decline of honey bees (Spivak et al., 2011). Among the multiple factors potentially responsible for this phenomenon, agricultural pesticide applications seem to contribute to this global bee's population decline (Gross, 2011). Nevertheless, little is known about the use of pesticide biomarkers in bees. Past studies have documented many biochemical aspects of bees CbEs. As with many other organisms, multiple CbE isozymes are generally found in the bee (Krieg & Marek, 1983), which play an important role in the metabolism of pesticides (Yu et al., 1984). Frohlich (1990) compared the hydrolytic activity of CbE in males and females of the solitary bee *Megachile rotundata* using multiple substrates. Bee sex had a significant impact on the variability of CbE activity. It was suggested that esterases of *M. rotundata* may be involved in the nest construction which would explain the higher levels of CbE activity in the females. This speculation suggests further exploration to examine whether anti-ChE pesticides are able to disrupt nest performance by inhibition of CbE activity because this enzyme is likely involved in the chemical process that leads to the formation of the brood cells (Frohlich, 1990). Isopods are another group of invertebrates that, despite of their growing concern in terrestrial ecotoxicology (Drobne, 1997), their esterases have been little studied in relation to pesticide contamination. Stanek et al. (2006) compared the inhibitory response of AChE activity in both adults and juveniles *P. scaber* exposed to diazinon-spiked food for two weeks. They found that AChE activity of juveniles was more sensitive to the OP than that of adults. Moreover, inhibition of AChE activity was linked to mortality of isopods, however other biological traits such as feeding activity or weight change did not vary with the diazinon exposure. The study by van Erp et al. (2002) is an example on the toxic effects of pesticides on a pest natural enemy. The wolf spider (*Lycosa hilaris*) is frequently found in the agroecosystem and it is a natural predator of many pest species. Cholinesterase activity was investigated in adults of this arachnid exposed to environmentally realistic concentrations of diazinon and chlorpyrifos. A ChE inhibition >80 % was associated to high mortality of male and female spiders in both laboratory and mesocosm trials, although females were more resistant to the toxic action by diazinon (van Erp et al., 2002).

Despite the widespread use of ChE inhibition as a sensitive indicator of OP and CM exposure, its use in terrestrial invertebrates sampled from, or caged in, the agroecosystem has been little explored. The soil-dwelling earthworm *A. caliginosa* has been used for monitoring OP exposure in the agroecosystem (Reinecke & Reinecke, 2007). Although ChE inhibition was recorded in the earthworms, it was not possible to make clear predictions at whole-individual level (e.g., changes in behaviour). Inhibition of ChE activity in earthworms and terrestrial snails has been satisfactorily used to distinguish the impact of multiple pest



control strategies in apple orchards (Denoyelle et al., 2007; Mazzia et al., 2011). These field studies only show that exposure to anti-ChE pesticides took place in the moment of specimens' collection, but information about detrimental effects at whole-individual level, indirect effects on other non-target organisms, or recovery of inhibited ChE is unknown. As argued by others, species selection, exposure design (e.g., *in situ* exposure, mesocosm), simulated pesticide applications, selection of tissues according to the mode of toxic action or detoxification pathways, among other factors, should be considered before planning a biomonitoring program for assessing environmental impact of post-authorized pesticides (Newman et al., 2006; Sanchez-Hernandez, 2010).

Esterases are generally considered indicators of toxicant's absorption. In addition, mammalian BChE and CbE activities are efficient bioscavengers of OPs reducing the impact of these compounds on brain AChE activity (Masson & Lockridge, 2010; Maxwell & Brecht, 2001; Wheelock et al., 2005). For example, Dettbarn et al. (1999) demonstrated that rat plasma CbE activity decreased the acute toxicity of paraoxon and, furthermore, a rapid recovery of both plasma and liver CbE activities following OP exposure contributed to a lack of toxicity. Beside the affinity of esterases for OP compounds, the number of enzyme molecules is also critical in the efficacy of this stoichiometric mechanism of detoxification. For example, Chanda et al. (1997) observed that liver CbE activity of female and male rats showed the same affinity for binding chlorpyrifos-oxon, however the liver of males had twice specific CbE activity than the liver of females. This variation in the CbE activity was a determinant factor in OP toxicity beside of CbE affinity for these pesticides. On the other hand, the interaction of these esterases with CM insecticides is a reversible inhibition that destroys chemically the parent compound (*see* Fig. 5). Taken together, these studies lead to postulate that BChE and CbE activities contribute significantly to modulate the acute toxicity of OPs and CMs. However, little is known about the detoxification role of BChE and CbE activities in terrestrial invertebrates.

## 2.2 Glutathione S-transferases and other related antioxidant enzymes.

Many agrochemicals such as OP insecticides are able to induce oxidative stress (Lukaszewicz-Hussain, 2010), a situation in which the production of reactive oxygen species (ROS) overcomes the cellular antioxidant mechanisms (molecular and enzymatic), leading to the oxidative damage of biomolecules (e.g., lipids, proteins or DNA). Glutathione level is one of the most used biomarker of pro-oxidant exposure in fish (van der Oost et al., 2003) and birds (Koivula & Eeva, 2010). In the detoxification of environmental contaminants, glutathione plays two main roles (van der Oost et al., 2003):

1. This tripeptide acts directly as a scavenger of ROS. In this interaction, the reduced glutathione (GSH) is oxidized to the disulfide form (GSSG). Thus, the GSH/GSSG ratio is a suitable biomarker of oxidative stress.
2. Glutathione is the cofactor of some enzymatic reactions involved in the metabolism of xenobiotics. For example, glutathione S-transferases (GSTs) use glutathione to form a conjugated metabolite with electrophilic intermediates that, in turn, are generated from the phase-I metabolism of xenobiotics. Similarly, hydrogen peroxide and other organic hydroperoxides are reduced to their corresponding alcohols by the action of glutathione peroxidases (GPx) which use glutathione as a cofactor. In this reaction GSH is oxidized to GSSG.

The GSSG formed during these detoxication pathways is reduced back to GSH by the glutathione reductase (GR), which is an essential enzyme in the GSH/GSSG balance. In summary, the GSH/GSSG ratio as well as the main enzymes involved in its redox homeostasis are proposed as sensitive exposure biomarkers of cellular oxidative stress (Koivula & Eeva, 2010; Maity et al., 2008; van der Oost et al., 2003). Few studies have been concerned with changes in glutathione concentration and glutathione-dependent enzymes in terrestrial invertebrates. Biomarkers of oxidative stress have been mainly explored in earthworms exposed to, or inhabiting in, metal-polluted environments. For example, earthworm GST activity is a noteworthy detoxication system (Stenersen, 1984), which is induced in earthworms exposed to organochlorine pesticides (Hans et al., 1993). However, no effects on this enzyme activity were observed in earthworms exposed to the OP fenitrothion (Booth & O'Halloran, 2001) or the CM carbaryl (Ribera et al., 2001). Herbicides also induce the GST activity of earthworms. For example, a strong induction of GST activity was found in *E. fetida* exposed for 24 and 48 h to fenoxaprop and metolachlor (Aly & Schröder, 2008). In the terrestrial isopod *P. scaber*, GST activity increased after two weeks of dietary exposure to 5 µg/g imidacloprid, but decreased in adults exposed to 25 µg/g of this neonicotinoid insecticide (Drobne et al., 2008). Despite this limited number of studies, it is not clear how the enzymatic (e.g., GST, GR, GPx, catalase, etc.) and molecular (e.g., GSH) antioxidant mechanisms work in terrestrial invertebrates exposed to pesticide-contaminated environments.

### 2.3 Behavioral changes as indicators of pesticide exposure

Behavior is the final integrated result of a diversity of physiological processes interacting with the surrounding abiotic and biotic components (Adkins-Regan & Weber 2002). In soil toxicity testing, body weight changes and reproduction rate are common sublethal toxicity endpoints. However, there is a growing concern to include new sublethal variables with ecological relevance such as behavior (Hellou, 2011). Many investigations have evidenced that pesticides are able to cause behavioral changes. Acephate (Moulton et al., 1996) and dichlorvos (McHenery et al., 1997) altered the ability of mussels to retract the mantle fringes and close the valves. The OP azamethiphos caused significant changes in the sheltered behavior of juvenile lobsters (*Homarus americanus*) (Abgrall et al., 2000). Similarly, the literature is plenty of examples describing perturbation or disruption of physiological systems directly involved in fish behavior (Scott & Sloman, 2004). Behavior is also a sensitive indicator of pesticide exposure in invertebrates. For example, the OP dimethoate caused significant changes in the locomotor activity of the collembolan *Folsomia candida* (Sorensen et al., 1995). Burrowing of *A. caliginosa* was examined in soil spiked with parathion-ethyl and this behaviour was more sensitive than ChE inhibition (Olveravelona et al., 2008). Similarly, a bioassay with the terrestrial isopod *Porcellio dilatatus* and dimethoate evidenced a significant relationship between ChE inhibition and locomotor impairment following 48 h of OP exposure (Engenheiro et al., 2005). Moreover, although such a correlation was lost within 10 d of pesticide exposure, locomotor variables (path length, average velocity, active time or stops per path) and AChE activity were still affected by the OP (1–60 µg/g soil).

According to the concept of a hierarchical cascade of biological responses to pollutants, sub-individual biomarkers should be linked to behavioral responses. The OP and CM pesticides are a good example to test this hypothesis. Their primary mechanism of acute toxicity is the



inhibition of the AChE activity at the nervous system and neuromuscular junction. A severe inhibition of this enzyme should cause behavior changes mediated by cholinergic synapses. A good example of such a relationship is the study by Beauvais and coworkers. A correlation between inhibition of brain AChE activity and decreasing of swimming speed was found in larval rainbow trout exposed for 24 and 48 h to carbaryl (Beauvais et al., 2001). In other related study, changes in the swimming speed or distance of larval rainbow trout exposed to malathion and diazinon significantly correlated with AChE inhibition (Beauvais et al., 2000). In the light of these studies, implementation of biochemical biomarkers directly implicated in behavior (e.g., AChE inhibition) could increase the toxicological meaning of behavior bioassays for assessing soil pollution.

The standardized avoidance behavior test with earthworms is an example of how behavior changes can be used easily as a screening toxicity test of soil pollution (ISO, 2005). The most common design to carry out the avoidance behavior test is a two-chamber system (ISO, 2005). This is a rectangular container which is divided in two equal compartments by a removable plastic separator. A control soil is placed in a compartment whereas the contaminated soil is placed in the other. Earthworms are then released in the middle of the rectangular container after remove the plastic split. Elapsed a period of exposure (normally 48 h), the plastic separator is inserted again in the middle of the container and individuals are counted in each soil compartment. The avoidance response is judged as positive when a percent of live earthworms higher than 80 % is found in the compartment containing the reference soil. This simple test can be of ecological concern because this escape behavior could alter the earthworm community of the soil or to change earthworm-induced physicochemical properties of soil. However, the meaning of the avoidance behavior test may be modified whether earthworms are released in the chamber containing the contaminated soil and after a fixed period of time, the separator is removed enabling to earthworms move toward the clean soil (Rodríguez-Castellanos & Sanchez-Hernandez, 2007). With this alternative approach, avoidance ability, locomotor activity and AChE inhibition can be evaluated all together and quantitative relationships may be established in relation to pesticide exposure; which is an important aspect not considered in the standardized avoidance behavior test. Attempts to increase the environmental realism of the avoidance behavior response test have been performed by others. For example, a vertical avoidance behavior test was proposed by Ellis et al. (2010) to be used with soil-dwelling earthworms. Inclusion of biomarkers directly related to pesticide toxicity (ChE inhibition) and detoxification (CYP-dependent monooxygenases, GST or CbEs) could be helpful in the understanding of the underlying mechanistic events that yield toxic-induced behavior responses or behavioral adaptive responses (Pereira et al., 2010).

### **3. Some methodological issues with biomarkers**

#### **3.1 Tissue-specific analysis**

Selection of the target tissue or organ is critical for biomarker analysis. However, many studies have used the whole organism or pooled individuals for biomarker determinations. Moreover, when the body size is often not sufficiently large to perform accurate molecular and biochemical analysis, portions of the animal where is suspected a high concentration of the proteins of interest are used for biomarker measurements (Rault et al., 2007; Ribeiro et al., 1999). The biomarker literature is, however, plenty of examples that illustrate significant

tissue-specific variations in biomarker responses and sensitivity to environmental pollutants. For example, *E. fetida* has two different ChEs with a marked difference in OP and CM sensitivity (Aamodt et al., 2007; Stenersen, 1980). Likewise, when earthworm ChE and CbE activities are measured in a tissue-dependent way, there is a strong variation in the activity levels of these esterases (Rault et al., 2007; Sanchez-Hernandez & Wheelock, 2009). Our laboratory has determined the normal variation of ChE and CbE activities in the soil-dwelling earthworm *L. terrestris* (Fig. 6A). The highest levels of ChE activity were observed in the body wall muscle and the pharynx, the latter probably as a consequence of the nervous tissue (ganglions) dissected together with the pharynx (Fig. 6B). This esterase

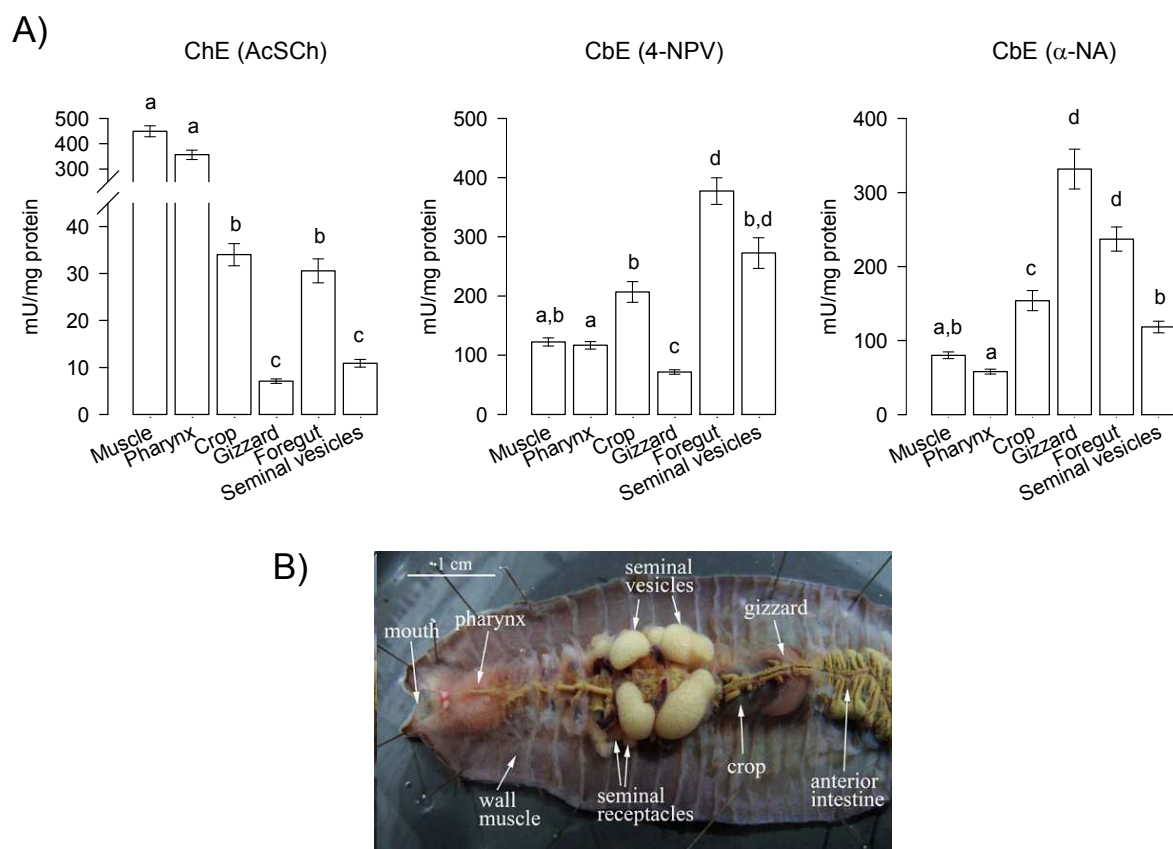

Fig. 6. A) Cholinesterase (ChE) and carboxylesterase (CbE) activities in multiple tissues of the earthworm *Lumbricus terrestris*. The substrate acetylthiocholine iodide (AcSCh) was used for ChE determination, whereas CbE activity was assayed using  $\alpha$ -naphthyl acetate ( $\alpha$ -NA) and 4-nitrophenyl valerate (4-NPV). B) Internal anatomy of *L. terrestris* showing some structures and organs of the gastrointestinal tract, and the reproductive system. Bars are the mean and the standard errors of 36 individuals. Different lower case letters denote significant differences (pairwise multiple comparison Dunn's test,  $P < 0.05$ ).

Data taken from the supplementary material provided in González Vejares et al. (2010) and Collange et al. (2010). Photograph of the internal anatomy of *L. terrestris* was kindly provided by Christopher Mazzia and previously published in Sanchez-Hernandez and Wheelock (2009).

activity showed a marked regional variation along the alimentary canal of *L. terrestris*. Carboxylesterase activity also displayed a tissue-specific variation of its hydrolytic activity towards two common substrates, i.e.,  $\alpha$ -naphthyl acetate ( $\alpha$ -NA) and 4-nitrophenyl valerate (4-NPV). Although the hydrolysis of both substrates could be carried out by the same CbEs, the activities measured in the gizzard suggested the presence of multiple isozymes with a different substrate preference (Fig. 6A).

Beside this marked tissue-specific variation in esterase activity, its sensitivity to pesticide is also highly dependent on the tissue where esterases are expressed. For example, Sanchez-Hernandez & Wheelock (2009) found that the *in vitro* inhibition of CbE activity by chlorpyrifos-oxon varied with the tissue. Furthermore, the substrate used for CbE measurements evidenced multiple isozymes with marked differences in sensitivity to chlorpyrifos-oxon. In general, IC<sub>50</sub> values for CbE activity using 4-NPV were lower than those reported with the use of 4-nitrophenyl acetate (4-NPA) (Sanchez-Hernandez & Wheelock, 2009).

These *in vitro* outcomes have been reproduced in microcosm trials (Collange et al., 2010; González Vejares et al., 2010). Earthworms (*L. terrestris*) exposed to chlorpyrifos-spiked soils for 2 days showed a tissue-specific variation in ChE and CbE inhibition, and the recovery pattern of the enzyme activities was also different dependent on the tissue and, in the case of CbE activity, the substrate used in the enzyme assay (Fig. 7). As with other organisms, the CbE activity was more sensitive to chlorpyrifos exposure than ChE activity, but not all tissues showed such a response. For example, gizzard ChE activity was more depressed than CbE activity (Fig. 7). Moreover, when  $\alpha$ -NA was used as the substrate for CbE measurements, we found a significant increase of this esterase activity compared to controls. These microcosm studies clearly indicate that determination of esterase inhibition as a biomarker of pesticide exposure should be made in a tissue-specific way, instead of using the whole organism or portions containing multiple tissues. A similar conclusion can be drawn from other detoxifying enzymes such as cytochrome P450-dependent monooxygenases (Stenersen, 1984) or GST activity (LaCourse et al., 2009).

### 3.2 Substrate-specific analysis

In general, enzyme kinetic procedures (e.g., spectrophotometric assays) used in invertebrates are directly reproduced, or include slight modifications, from those validated for mammals. However, the biochemistry and physiology of terrestrial invertebrates such as earthworms or isopods are not well known as in mammals, and there is a serious risk of making erroneous conclusions about the toxic effects of environmental contaminants. Some biochemical biomarkers are commonly measured in aquatic and terrestrial invertebrates using protocols developed and optimized for mammals. For example, specific inhibitors for AChE (BW284C51) and BChE (tetraisopropyl pyrophosphoramidate or iso-OMPA) activities or selective substrates (acetyl- $\beta$ -(methyl)thiocholine for AChE or butyrylthiocholine for BChE) allow to distinguish both ChEs when co-exist in the same tissue or organ. Although this approach is suitable for mammalian ChE activities, when it is used with terrestrial invertebrates arises atypical or overlapping mammalian ChEs-type properties (Rault et al., 2007; Stenersen, 1980). For example, ChE activity of *E. andrei* was not sensitive to iso-OMPA when the esterase activity was assayed with butyrylthiocholine but was sensitive to the inhibition by BW284C51 (Caselli et al., 2006). However, Stenersen (1980) used

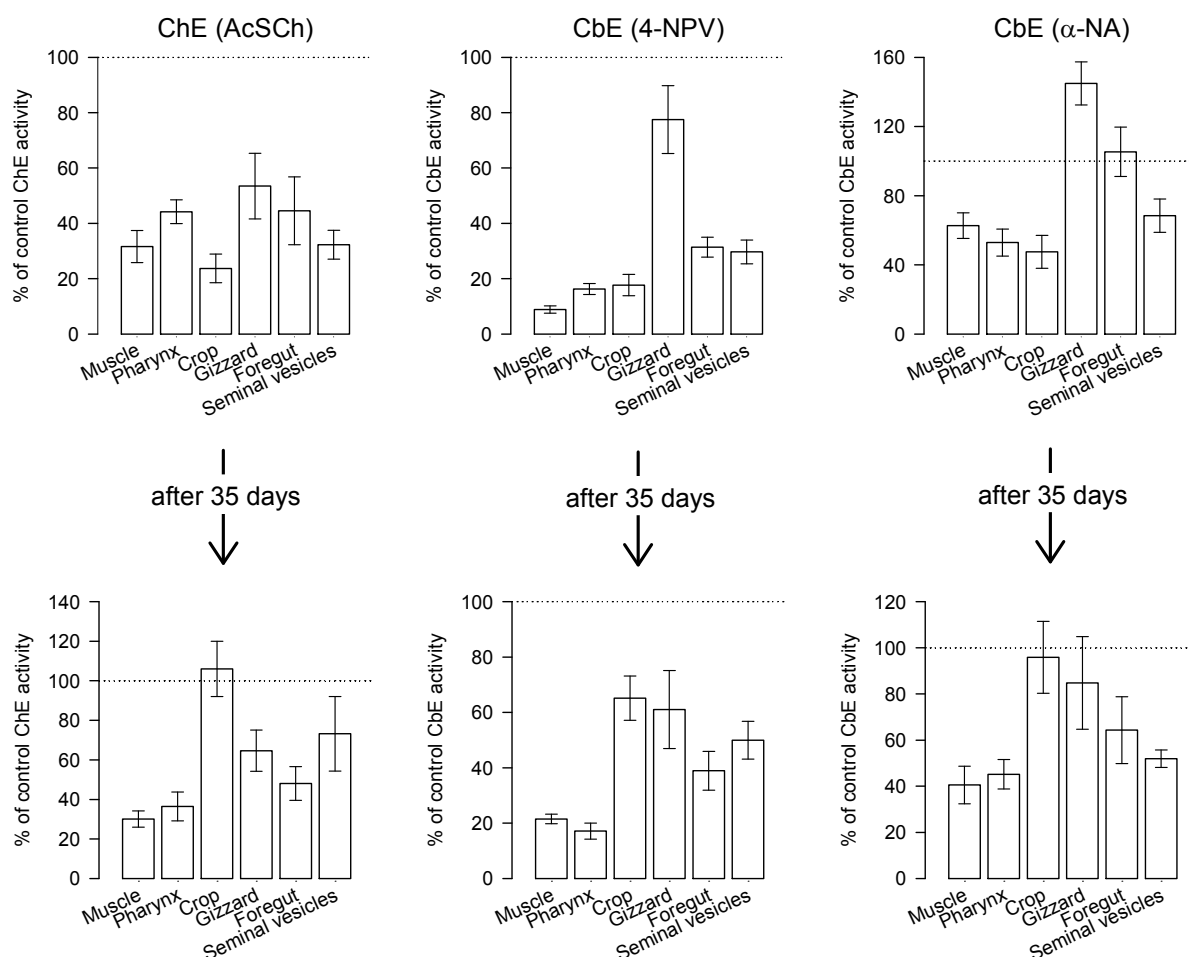

Fig. 7. Percentages of remaining cholinesterase (ChE) and carboxylesterase (CbE) activities measured in multiple tissues of the earthworm *Lumbricus terrestris* following two days of exposure to soils spiked with 48 mg/kg dry wt chlorpyrifos, and after 35 days of transferring earthworms into clean soils. The substrate acetylthiocholine iodide (AcSCh) was used for ChE determination, whereas CbE activity was assayed using  $\alpha$ -naphthyl acetate ( $\alpha$ -NA) and 4-nitrophenyl valerate (4-NPV). Bars are the mean and the standard errors of 6 individuals. Data taken from the supplementary material provided in González Vejares et al. (2010) and Collange et al. (2010). Horizontal dotted lines indicate the mean esterase activity of controls set to 100%.

carbaryl as a specific inhibitor to differentiate two ChEs in *E. fetida*, a mammalian-type AChE activity named by the author as E1 and a mammalian-type BChE activity named E2 (carbaryl-resistant ChE). These earthworm ChE activities showed different recovery rates following exposure to chlorpyrifos (Aamodt et al., 2007), which indicate that determination of both ChEs should be performed individually to know the real impact of OP exposure on ChEs of this earthworm species.

The measurement of CbE activity is another example that illustrates why common substrates routinely used for enzymatic assays should be implemented in invertebrates with some reservations. Carboxylesterases comprise multiple isozymes whose number and activity depend on the tissue where they are present (Satoh & Hosokawa, 2006; Wheelock et al., 2008). These esterases display a broad range of substrate specificity (Wheelock et al.,



2005). Naphthyl and nitrophenyl esters are the usual substrates for CbE determinations, and some researchers recommend the use of multiple substrates when these esterases are used as biomarkers of pesticide exposure (Wheelock et al., 2005; Wheelock et al., 2008). However, most of the ecotoxicological studies use one or two substrates (usually  $\alpha$ -NA or 4-NPA) to determine the CbE activity with the risk that these substrates be not efficiently hydrolyzed. On the other hand, because these substrates have not any known biological significance, it is difficult to understand the toxicological meaning of CbE activity and inhibition. In mammals, some authors have used more realistic substrates from an environmental and pharmacological viewpoint. Thus, liver and intestinal CbE activities were able to hydrolyze efficiently type-I pyrethroids compared to type-II pyrethroids (Ross et al., 2006; Ross & Crow, 2007). In addition, the hydrolysis kinetic parameters usually obtained with SPT insecticides are different to those obtained with common substrates such as 4-NPA or 4-NPV. Indeed, it is suggested that different CbE isozymes are involved in the hydrolysis of pyrethroids and the nitrophenyl esters (Wheelock et al., 2003). Our studies with *L. terrestris* also show the occurrence of multiple CbE isozymes with marked differences in substrate specificity in the gastrointestinal, reproductive and muscle tissues (Fig. 6). More recently, we have detected pyrethroid hydrolysis by CbEs in the earthworm gut, which does not correlate with the CbE activity towards naphthyl or nitrophenyl esters (Sanchez-Hernandez, pers. comm.).

Glutathione S-transferases and cytochrome P450-dependent monooxygenases (CYPs) are two groups of detoxifying enzymes that participate in the biotransformation of lipophilic compounds (Hodgson, 2010). For example, GST activity catalyzes glutathione-aryltransfer or glutathione-alkyltransfer reactions of OP insecticides forming non-toxic conjugate metabolites (Jokanovic, 2001). In routine assays, GST activity is determined by a spectrophotometric assay in which the substrate 1-chloro-2,4-dinitrobenzene is conjugated with GSH to form a conjugated metabolite, i.e., 1-(S-glutathionyl)-2,4-dinitrobenzene, which is monitored at 340 nm (Habig et al., 1974). This is the most common spectrophotometric method to determine GST activity for biomonitoring purposes. Again, the occurrence of multiple forms of GST (cytosolic and microsomal) not only in mammals (Hayes et al., 2005) but also in earthworms (Aly & Schröder, 2008; LaCourse et al., 2009) suggests that more than one substrate should be used for exploring induction or inhibition of GST activity by pesticides. Ethoxyresorufin-O-deethylase (EROD) activity is the most common enzymatic assay to measure the induction of the cytochrome P4501A (CYP1A) isozyme (van der Oost et al., 2003; Whyte et al., 2000). This isozyme plays a pivotal role in the detoxication and bioactivation of pesticides. For example, CYP1A catalyzes the conversion of phosphorothioate- and phosphorodithioate-type OP pesticides into their highly toxic 'oxon' forms (Jokanovic, 2001). Earthworms present two CYP subfamilies, i.e., the polyaromatic hydrocarbon-inducible form (CYP1A) and the phenobarbital-inducible form (CYP2B) (Stenersen, 1984). However, there is a marked species-specific difference in the catalytic properties of CYPs and induction capability. For example, microsomes of *L. terrestris* midgut showed CYP activity when benzyloxyresorufin was used as substrate, but no dealkylation activity was detected towards other resorufin derivatives such as methyloxy-, ethyloxy- or propyloxyresorufin (Bergholjt et al., 1991). Conversely, microsomes of whole *E. fetida* displayed CYP activity when benzyloxy- and pentyloxyresorufin were used as substrates (Achazi et al., 1998). *Lumbricus rubellus* did not show detectable CYP1A activity using EROD as the catalytic assay even when earthworms were exposed to known inducers of CYP1A

activity (Brown et al., 2004). Taken together, these studies show that CYP activity is highly dependent on substrate and earthworm species. However, the role of this detoxifying multienzymatic system should be investigated in detail in pesticide-exposed earthworms to propose the most appropriate substrates to measure induction (or inhibition) of CYP450 activity.

### 3.3 Complementary methods

The chemical reactivation of the phosphorylated ChE activity using oximes is a workable methodology of assessment of wildlife exposure to OP insecticides in vertebrates. However, this approach has not had a comparable attention with terrestrial invertebrates. Some laboratory studies have proved that oximes are able to recover the activity of the OP-inhibited ChE activity in earthworms (Rodriguez and Sanchez-Hernandez 2007), snails (Laguerre et al. 2009) and honey bees (Polyzou et al. 1998). One of the main limitations of this method is the lack of oxime-induced reactivation when the esterase remains long time inhibited. However, this drawback could still be useful for detecting multiple and short-term exposures to OP insecticides because aged ChE and new synthesized ChE could be estimated with the use of oximes. For example, ChE activity of the earthworm *L. terrestris* was significantly reactivated with 2-PAM or obidoxime within one week following acute OP exposure, although such a chemically-induced recovery decreased with time as a consequence of ChE aging (Collange et al. 2010). Thus, comparison of ChE activity levels between OP-exposed and control earthworms in combination with oxime reactivation assays would enable to detect inhibition of newly synthesized enzyme if earthworms suffer an additional OP exposure event. Nonetheless, optimization of oxime-induced reactivation of phosphorylated ChE activity should be performed when we use a new species or a new tissue as target for ChE determination and reactivation.

## 4. Concluding remarks

Plant protection products are still necessary for combat pests. The massive use of pesticides leads to a set of environmental hazards on non-target organisms of ecological and agronomic concerns such as earthworms, pollinators or natural enemies of pests. Moreover, the occurrence of pesticide residues in soil can change microbial communities and soil enzyme activities involved in nutrient cycles. These effects can lead, in turn, to a loss of soil quality. In the predictive and retrospective (post-authorized) environmental risk assessment of PPPs, exposure and effect assessment of pesticide toxicity on non-target organisms is an essential step for decision-making related to pesticide use and agroecosystem protection. Besides toxicity and bioaccumulation bioassays, biomarkers are often used to provide mechanistic understandings on the toxic effects observed at the whole-organism level. Classical biochemical biomarkers have been used in terrestrial invertebrates, mainly earthworms, to assess exposure to OP and CM pesticides. Below it is emphasized a set of practical issues that would require further investigation to use biochemical biomarkers in the understanding of pesticide toxicity and tolerance in terrestrial invertebrates.

When possible, the analysis of biomarkers should be performed in a tissue-specific way because level, degree of response or persistence of the response is highly dependent on the tissue. Moreover, a tissue-specific analysis of the biomarkers can be helpful to understand local toxic effects of pesticides or possible mechanisms involved in the reduction of pesticide



uptake and detoxication (e.g., sensitivity and expression of pesticide-detoxifying enzymes in the gastrointestinal tract).

Linking biochemical biomarkers to behavior changes is a growing ecotoxicological topic that requires further studies aimed to examine adaptive behavior responses following pesticide exposure, or the impact of long-term and low-level pesticide exposure on the “behavior-biomarkers” interaction. Current behavior protocols such as the standardized avoidance behavior bioassay with earthworms (ISO, 2005) and other more ecologically relevant alternatives provide an excellent opportunity to link those biomarkers directly related to pesticide toxicity and metabolism with behavior.

When enzyme inhibition (e.g., CbEs or ChEs) or induction (e.g., GST or CYP1A) are used to assess pesticide toxicity and detoxication, appropriate substrates or multiple substrates are recommended because of multiple isozymes co-existing in the target tissue or organ. Some studies discussed in this chapter have demonstrated that earthworm CbE activity (an esterase of notable importance in the metabolism of OP, CM and SPT pesticides) display multiple tissue-specific isozymes and, further, these isozymes respond (inhibition and recovery) differently to OP exposure.

When ChE activity is used as a biomarker of pesticide exposure, it is recommended the use of oximes (nucleophilic compounds able to restore the ChE activity following OP exposure). Some studies with earthworms have shown that phosphorylated ChE activity can be reversed *in vivo* and *in vitro* by pralidoxime and obidoxime. This methodology would allow to assess multiple OP exposures in the field or to examine the potential contribution of ChEs (AChE and BChE) as bioscavengers of OP pesticides.

## 5. Acknowledgements

The author is grateful for the financial support of the Ministerio de Ciencia e Innovación (CTM 2006-11828/TECNO) and the Consejería de Educación y Ciencia (PCI08-0049-0228).

## 6. References

- Aamodt, S., Konestabo, H. S., Sverdrup, L. E., Gudbrandsen, M., Reinecke, S. A., Reinecke, A. & Stenersen, J. (2007). Recovery of cholinesterase activity in the earthworm *Eisenia fetida* Savigny following exposure to chlorpyrifos. *Environmental Toxicology and Chemistry*, 26, 1963-1967.
- Abgrall, P., Rangeley, R. W., Burridge, L. E. & Lawton, P. (2000). Sublethal effects of azamethiphos on shelter use by juvenile lobsters (*Homarus americanus*). *Aquaculture*, 181, 1-10.
- Abhilash, P. C. & Singh, N. (2009). Pesticide use and application: An Indian scenario. *Journal of Hazardous Materials*, 165, 1-12.
- Achazi, R. K., Flenner, C., Livingstone, D. R., Peters, L. D., Schaub, K. & Scheiwe, E. (1998). Cytochrome P450 and dependent activities in unexposed and PAH-exposed terrestrial annelids. *Comparative Biochemistry and Physiology - Part C: Toxicology and Pharmacology*, 121, 339-350.
- Aly, M. A. S. & Schröder, P. (2008). Effect of herbicides on glutathione S-transferases in the earthworm, *Eisenia fetida*. *Environmental Science and Pollution Research*, 15, 143-149.

- Barata, C., Solayan, A. & Porte, C. (2004). Role of B-esterases in assessing toxicity of organophosphorus (chlorpyrifos, malathion) and carbamate (carbofuran) pesticides to *Daphnia magna*. *Aquatic Toxicology*, 66, 125-139.
- Barker, A. V. & Bryson, G. M. (2002). Bioremediation of heavy metal and organic toxicants by composting. *TheScientificWorldJournal*, 2, 407-420.
- Beauvais, S. L., Jones, S. B., Brewer, S. K. & Little, E. E. (2000). Physiological measures of neurotoxicity of diazinon and malathion to larval rainbow trout (*Oncorhynchus mykiss*) and their correlation with behavioral measures. *Environmental Toxicology and Chemistry*, 19, 1875-1880.
- Beauvais, S. L., Jones, S. B., Parris, J. T., Brewer, S. K. & Little, E. (2001). Cholinergic and behavioral neurotoxicity of carbaryl and cadmium to larval rainbow trout (*Oncorhynchus mykiss*). *Ecotoxicology and Environmental Safety*, 49, 84-90.
- Bergholjt, A. G. R. V., Wenzel, E., Büld, J. & Netter, K. J. (1991). Isolation, partial purification, and characterization of the cytochrome 450-dependent monooxygenase system from the midgut of the earthworm *Lumbricus terrestris*. *Comparative Biochemistry and Physiology*, 100C, 389-396.
- Bianchi, F. J. J. A., Booij, C. J. H. & Tschardtke, T. (2006). Sustainable pest regulation in agricultural landscapes: a review on landscape composition, biodiversity and natural pest control. *Proceedings of the Royal Society B: Biological Sciences*, 273, 1715-1727.
- Booth, L. H., Hodge, S. & O'Halloran, K. (2000). Use of cholinesterase in *Aporrectodea caliginosa* (Oligochaeta; Lumbricidae) to detect organophosphate contamination: comparison of laboratory tests, mesocosms, and field studies. *Environmental Toxicology and Chemistry*, 19, 417-422.
- Brown, P., Long, S., Spurgeon, D., Svendsen, C. & Hankard, P. (2004). Toxicological and biochemical responses of the earthworm to pyrene, a non-carcinogenic polycyclic aromatic hydrocarbon. *Chemosphere*, 57, 1675-1681.
- Cáceres, T., Megharaj, M., Venkateswarlu, K., Sethunathan, N. & Naidu, R. (2010). Fenamiphos and related organophosphorus pesticides: environmental fate and toxicology. *Reviews of Environmental Contamination and Toxicology*, 205, 117-162.
- Capowiez, Y., Rault, M., Mazzia, C. & Belzunces, L. (2003). Earthworm behaviour as a biomarker - a case study using imidacloprid. *Pedobiologia*, 47, 542-547.
- Caselli, F., Gastaldi, L., Gambi, N. & Fabbri, E. (2006). In vitro characterization of cholinesterases in the earthworm *Eisenia andrei*. *Comparative Biochemistry and Physiology Part C: Toxicology & Pharmacology*, 143, 416-421
- Chapman, P. M. (2002). Integrating toxicology and ecology: putting the "eco" into ecotoxicology. *Marine Pollution Bulletin*, 44, 7-15.
- Coeurdassier, M., Gomot-de Vaufleury, A., Saint-Denis, M., Ribera, D., Narbonne, J. F. & Badot, P. M. (2002). Effects of dimethoate on snail B-esterase and growth as a function of dose, time and exposure route in a laboratory bioassay. *Biomarkers*, 7, 138-150.
- Collange, B., Wheelock, C. E., Rault, M., Mazzia, C., Capowiez, Y. & Sanchez-Hernandez, J. C. (2010). Inhibition, recovery and oxime-induced reactivation of muscle esterases following chlorpyrifos exposure in the earthworm *Lumbricus terrestris*. *Environmental Pollution*, 158, 2266-2272.

- Denoyelle, R., Rault, M., Mazzia, C., Mascle, O. & Capowiez, Y. (2007). Cholinesterase activity as a biomarker of pesticide exposure in *Allolobophora chlorotica* earthworms living in apple orchards under different managements strategies. *Environmental Toxicology and Chemistry*, 26, 2644-2649.
- Devine, G. J. & Furlong, M. J. (2007). Insecticide use: Contexts and ecological consequences. *Agriculture and Human Values*, 24, 281-306.
- Devotto, L., Carrillo, R., Cisternas, E. & Gerding, M. (2007). Effects of lambda-cyhalothrin and *Beauveria bassiana* spores on abundance of Chilean soil surface predators, especially spiders and carabid beetles. *Pedobiologia*, 51, 65-73.
- Domingues, I., Agra, A. R., Monaghan, K., Soares, A. M. V. M. & Nogueira, A. J. A. (2010). Cholinesterase and glutathione-S-transferase activities in freshwater invertebrates as biomarkers to assess pesticide contamination. *Environmental Toxicology and Chemistry*, 29, 5-18.
- Drobne, D. (1997). Terrestrial isopods - a good choice for toxicity testing of pollutants in the terrestrial environment. *Environmental Toxicology and Chemistry*, 16, 1159-1164.
- Drobne, D., Blazic, M., van Gestel, C.A.M., Leser, V., Zidar, P. Jemec, A. & Trebse, P. (2008). Toxicity of imidacloprid to the terrestrial isopod *Porcellio scaber* (Isopoda, Crustacea). *Chemosphere*, 71, 1326-1334.
- Ellis, S. R., Hodson, M. E. & Wege, P. (2010). The soil-dwelling earthworm *Allolobophora chlorotica* modifies its burrowing behaviour in response to carbendazim applications. *Ecotoxicology and Environmental Safety*, 73, 1424-1428.
- Engenheiro, E.L., Hankard, P.K., Sousa, J.P., Lemos, M.F., Weeks, J.M. & Soares, A.M.V.M. (2005). Influence of dimethoate on acetylcholinesterase activity and locomotor function in terrestrial isopods. *Environmental Toxicology and Chemistry*, 24, 603-609.
- Essawy, A. E., Abdelmeguid, N. E., Radwan, M. A., Hamed, S. S. & Hegazy, A. E. (2008). Neuropathological effect of carbamate molluscicides on the land snail, *Eobania vermiculata*. *Cell Biology and Toxicology*, 25, 275-290.
- Eurostat (2007). The use of plant protection products in the European Union. 2007 edition, European Commission, Luxembourg, European Union.
- European Commission (2002). "Communication from the Commission to the Council, the European Parliament, the Economic and Social Committee and the Committee Of The Regions - Towards a Thematic Strategy for Soil Protection, COM, 179 final.
- Flavia G., Bengtssonb, J., Berendse, F., Weisser, W.W., Emmersond, M., Morales, M.B., Ceryngier, P., Liirah, J., Tschardtke, T., Winqvist, C., Eggers, S., Bommarcob, R., Pärt, T., Bretagnolle, V., Plantegenest, M., Clement, L.W., Dennis, C., Palmer, C., Oñate, J.J., Guerrero, I. Hawrog, V., Aavikh, T. Thies, C., Flohre, A., Hänke, S., Fischer, C., Goedhart, P.W. & Inchausti, P. (2010). Persistent negative effects of pesticides on biodiversity and biological control potential on European farmland. *Basic and Applied Ecology*, 11, 97-105.
- Fleeger, J., Carman, K. & Nisbet, R. (2003). Indirect effects of contaminants in aquatic ecosystems. *The Science of The Total Environment*, 317, 207-233.
- Forbes, V. E., Palmqvist, A. & Bach, L. (2006). The use and misuse of biomarkers in ecotoxicology. *Environmental Toxicology and Chemistry*, 25, 272-280.

- Frohlich, D. R. (1990). Substrate specificity of esterases in a solitary bee, *Megachile rotundata* (Hymenoptera: Megachilidae): variability in sex, age and life stage. *Biochemical Systematics and Ecology*, 18, 539-547.
- Fulton, M. H. & Key, P. B. (2001). Acetylcholinesterase inhibition in estuarine fish and invertebrates as an indicator of organophosphorus insecticide exposure and effects. *Environmental Toxicology and Chemistry*, 20, 37-45.
- Galloway, T. S., Brown, R. J., Browne, M. A., Dissanayake, A., Lowe, D., Jones, M. B. & Depledge, M. H. (2004). A multibiomarker approach to environmental assessment. *Environmental Science and Technology*, 38, 1723-1731.
- Gastaldi, L., Ranzato, E., Capri, F., Hankard, P., Peres, G., Canesi, L., Viarengo, A. & Pons, G. (2007). Application of a biomarker battery for the evaluation of the sublethal effects of pollutants in the earthworm *Eisenia andrei*. *Comparative Biochemistry and Physiology Part C: Toxicology & Pharmacology*, 146, 398-405.
- Gavrilescu, M. (2005). Fate of pesticides in the environment and its bioremediation. *Engineering in Life Science*, 5, 497-526
- Gianfreda, L. & Rao, M. (2008). Interactions between xenobiotics and microbial and enzymatic soil activity. *Critical Reviews in Environmental Science and Technology*, 38, 269-310.
- González Vejares, S., Sabat, P. & Sanchez-Hernandez, J. C. (2010). Tissue-specific inhibition and recovery of esterase activities in *Lumbricus terrestris* experimentally exposed to chlorpyrifos. *Comparative Biochemistry and Physiology Part C: Toxicology & Pharmacology*, 151, 351-359.
- Gross, M. (2011). New fears over bee declines. *Current Biology*, 21, R137-R139.
- Habig, W. H., Pabst, M. J. & Jakoby, W. B. (1974). Glutathione S-Transferases: the first enzymatic step in mercapturic acid formation. *The Journal of Biological Chemistry*, 249, 7130-7139.
- Hagger, J. A., Galloway, T. S., Langston, W. J. & Jones, M. B. (2009). Application of biomarkers to assess the condition of European Marine Sites. *Environmental Pollution*, 157, 2003-2010.
- Hans, R. K., Khan, M. A., Farooq, M. & Beg, M. U. (1993). Glutathione-S-transferase activity in an earthworm (*Pheretima posthuma*) exposed to three insecticides. *Soil Biology and Biochemistry*, 25, 509-511.
- Hayes, J. D., Flanagan, J. U. & Jowsey, I. R. (2005). Glutathione Transferases. *Annual Review of Pharmacology and Toxicology*, 45, 51-88.
- Hellou, J. (2011). Behavioural ecotoxicology, an "early warning" signal to assess environmental quality. *Environmental Science and Pollution Research*, 18, 1-11.
- Hemingway, J., Hawkes, N., McCarroll, L. & Ranson, H. (2004). The molecular basis of insecticide resistance in mosquitoes. *Insect Biochemistry and Molecular Biology*, 34, 653-665.
- Hodgson, E. (2010). Introduction to biotransformation (metabolism), In: *Hayes' Handbook of Pesticide Toxicology*, Krieger, R. (Ed.), 865-875, Academic Press, Burlington.
- Hyne, R. V. & Maher, W. A. (2003). Invertebrate biomarkers: links to toxicosis that predict population decline. *Ecotoxicology and Environmental Safety*, 54, 366-374.



- ISO (2005). Soil quality: Avoidance test for testing the quality of soils and the toxicity of chemicals – Tests with earthworms. International Organization for Standardization, Geneva.
- Jemec, A., Drobne, D., Tišler, T. & Sepčić, K. (2009). Biochemical biomarkers in environmental studies—lessons learnt from enzymes catalase, glutathione S-transferase and cholinesterase in two crustacean species. *Environmental Science and Pollution Research*, 17, 571-581.
- Jokanovic, M. (2001). Biotransformation of organophosphorus compounds. *Toxicology*, 166, 139-160.
- Karlen, D. L., Mausbach, M. J., Doran, J. W., Cline, R. G., Harris, R. F. & Schuman, G. E. (1997). Soil quality: a concept, definition, and framework for evaluation (a guest editorial). *Soil Science Society American Journal*, 61, 4-10.
- Katagi, T. (2004). Photodegradation of pesticides on plant and soil surfaces. *Reviews of Environmental Contamination and Toxicology*, 182, 1-195.
- Köhne, J., Köhne, S. & Simunek, J. (2009). A review of model applications for structured soils: b) Pesticide transport. *Journal of Contaminant Hydrology*, 104, 36-60.
- Koivula, M. J. & Eeva, T. (2010). Metal-related oxidative stress in birds. *Environmental Pollution*, 158, 2359-2370.
- Krieg, P. & Marek, M. (1983). Protein and esterase changes haemolymph of the queens of bee, *Apis mellifera* L. in the honey. *Comparative Biochemistry and Physiology*, 75B, 513-517.
- Kuster, E. (2005). Cholin- and carboxylesterase activities in developing zebrafish embryos (*Danio rerio*) and their potential use for insecticide hazard assessment. *Aquatic Toxicology*, 75, 76-85.
- LaCourse, E. J., Hernandez-Viadel, M., Jefferies, J. R., Svendsen, C., Spurgeon, D. J., Barrett, J., John Morgan, A., Kille, P. & Brophy, P. M. (2009). Glutathione transferase (GST) as a candidate molecular-based biomarker for soil toxin exposure in the earthworm *Lumbricus rubellus*. *Environmental Pollution*, 157, 2459-2469.
- Laguerre, C., Sanchez-Hernandez, J. C., Köhler, H.-R., Triebskorn, R., Capowiez, Y., Rault, M. & Mazzia, C. (2009). B-type esterases in the snail *Xeropicta derbentina*: An enzymological analysis to evaluate their use as biomarkers of pesticide exposure. *Environmental Pollution*, 157, 199-207.
- Landis, D. A., Gardiner, M. M., van der Werf, W. & Swinton, S. M. (2008). Increasing corn for biofuel production reduces biocontrol services in agricultural landscapes. *Proceedings of the National Academy of Sciences*, 105, 20552-20557.
- Lanno, R., Wells, J., Conder, J., Bradham, K. & Basta, N. (2004). The bioavailability of chemicals in soil for earthworms. *Ecotoxicology and Environmental Safety*, 57, 39-47.
- Lavelle, P., Pashanasi, B., Charpentier, F., Gilot, C., Rossi, J. P., Derouard, L., Andre, J., Ponge, J. F. & Bernier, N. (2004). Effects of earthworms on soil organic matter and nutrient dynamics at a landscape scale over decades, In: *Earthworm Ecology*, Edwards, C. A. (Ed.), 145-160, CRC Press, Boca Raton, USA.
- Lukaszewicz-Hussain, A. (2010). Role of oxidative stress in organophosphate insecticide toxicity – Short review. *Pesticide Biochemistry and Physiology*, 98, 145-150.

- Maity, S., Roy, S., Chaudhury, S. & Bhattacharya, S. (2008). Antioxidant responses of the earthworm *Lampito mauritii* exposed to Pb and Zn contaminated soil. *Environmental Pollution*, 151, 1-7.
- Mann, R. M., Hyne, R. V., Choung, C. B. & Wilson, S. P. (2009). Amphibians and agricultural chemicals: Review of the risks in a complex environment. *Environmental Pollution*, 157, 2903-2927.
- Masson, P. & Lockridge, O. (2010). Butyrylcholinesterase for protection from organophosphorus poisons: Catalytic complexities and hysteretic behavior. *Archives of Biochemistry and Biophysics*, 494, 107-120.
- Maxwell, D. M. & Brecht, K. M. (2001). Carboxylesterase: specificity and spontaneous reactivation of an endogenous scavenger for organophosphorus compounds. *Journal of Applied Toxicology*, 21, S103-S107.
- Mazzia, C., Capowiez, Y., Sanchez-Hernandez, J. C., Köhler, H.-R., Triebkorn, R. & Rault, M. (2011). Acetylcholinesterase activity in the terrestrial snail *Xeropicta derbentina* transplanted in apple orchards with different pesticide management strategies. *Environmental Pollution*, 159, 319-323.
- McHenery, J. G., Linley-Adams, G. E., Moore, D. C., Rodger, G. K. & Davies, I. M. (1997). Experimental and field studies of effects of dichlorvos exposure on acetylcholinesterase activity in the gills of the mussel, *Mytilus edulis* L. *Aquatic Toxicology*, 38, 125-143.
- Mirsal, I. A. (2008). Planning and realisation of soil remediation, In: *Soil Pollution: Origin, Monitoring and Remediation*, (Ed.), 265-299, Springer-Verlag, Berlin, Germany.
- Monserrat, J. M., Martínez, P. E., Geracitano, L. A., Lund Amado, L., Martinez Gaspar Martins, C., Lopes Leães Pinho, G., Soares Chaves, I., Ferreira-Cravo, M., Ventura-Lima, J. & Bianchini, A. (2007). Pollution biomarkers in estuarine animals: Critical review and new perspectives. *Comparative Biochemistry and Physiology Part C: Toxicology & Pharmacology*, 146, 221-234.
- Moulton, C. A., Fleming, W. J. & Purnell, C. E. (1996). Effects of two cholinesterase-inhibiting pesticides on freshwater mussels. *Environmental Toxicology and Chemistry*, 15, 131-137.
- Newman, M., Crane, M. & Holloway, G. (2006). Does pesticides risk assessment in the Europe Union assess long-term effects? *Reviews of Environmental Contamination and Toxicology*, 187, 1-65.
- Oakeshott, J., Devonshire, A., Claudianos, C., Sutherland, T., Horne, I., Campbell, P., Ollis, D. & Russell, R. (2005). Comparing the organophosphorus and carbamate insecticide resistance mutations in cholin- and carboxyl-esterases. *Chemico-Biological Interactions*, 157-158, 269-275.
- OECD (2009). "OECD in figures 2009", Organisation for Economic Co-operation and Development Publications, Paris, France.
- Olveravelona, A., Capowiez, Y., Mascle, O., Ortizhernandez, L. & Benoit, P. (2008). Assessment of the toxicity of ethyl-parathion to earthworms (*Aporrectodea caliginosa*) using behavioural, physiological and biochemical markers. *Applied Soil Ecology*, 40, 476-483.
- Peakall, D. (1992). Animal biomarkers as pollution indicators. Chapman & Hall, London.



- Pereira, J., Antunes, S., Ferreira, A., Goncalves, F. & Pereira, R. (2010). Avoidance behavior of earthworms under exposure to pesticides: Is it always chemosensorial? *Journal of Environmental Science and Health, Part B*, 45, 229-232.
- Potts, S. G., Biesmeijer, J. C., Kremen, C., Neumann, P., Schweiger, O. & Kunin, W. E. (2010). Global pollinator declines: trends, impacts and drivers. *Trends in Ecology & Evolution*, 25, 345-353.
- Racke, K. D. (1993). Environmental fate of chlorpyrifos. *Reviews of Environmental Contamination and Toxicology*, 131, 1-154.
- Rault, M., Mazzia, C. & Capowicz, Y. (2007). Tissue distribution and characterization of cholinesterase activity in six earthworm species. *Comparative Biochemistry and Physiology Part B: Biochemistry and Molecular Biology*, 147, 340-346.
- Rault, M., Collange, B., Mazzia, C. & Capowicz, Y. (2008). Dynamics of acetylcholinesterase activity recovery in two earthworm species following exposure to ethyl-parathion. *Soil Biology and Biochemistry*, 40, 3086-3091.
- Reinecke, S. & Reinecke, A. (2007). The impact of organophosphate pesticides in orchards on earthworms in the Western Cape, South Africa. *Ecotoxicology and Environmental Safety*, 66, 244-251.
- Ribeiro, S., Guilhermino, L., Sousa, J. P. & Soares, A. M. V. M. (1999). Novel bioassay based on acetylcholinesterase and lactate dehydrogenase activities to evaluate the toxicity of chemicals to soil isopods. *Ecotoxicology and Environmental Safety*, 44, 287-293.
- Ribera, D., Narbonne, J. F., Arnaud, C. & Saint-Denis, M. (2001). Biochemical responses of the earthworm *Eisenia fetida andrei* exposed to contaminated artificial soil, effects of carbaryl. *Soil Biology and Biochemistry*, 33, 1123-1130.
- Rodríguez-Castellanos, L. & Sanchez-Hernandez, J. C. (2007). Chemical reactivation and aging kinetics of organophosphorus-inhibited cholinesterases from two earthworm species. *Environmental Toxicology and Chemistry*, 26, 1992-2000.
- Rodríguez-Castellanos, L. & Sanchez-Hernandez, J. C. (2007). Earthworm biomarkers of pesticide contamination: Current status and perspectives. *Journal of Pesticide Science*, 32, 360-371.
- Ross, M., Borazjani, A., Edwards, C. & Potter, P. (2006). Hydrolytic metabolism of pyrethroids by human and other mammalian carboxylesterases. *Biochemical Pharmacology*, 71, 657-669.
- Ross, M. K. & Crow, J. A. (2007). Human carboxylesterases and their role in xenobiotic and endobiotic metabolism. *Journal of Biochemical and Molecular Toxicology*, 21, 187-196.
- Sanchez-Hernandez, J. C. (2001). Wildlife exposure to organophosphorus insecticides. *Reviews of Environmental Contamination and Toxicology*, 172, 21-63.
- Sanchez-Hernandez, J. C. & Wheelock, C. (2009). Tissue distribution, isozyme abundance and sensitivity to chlorpyrifos-oxon of carboxylesterases in the earthworm *Lumbricus terrestris*. *Environmental Pollution*, 157, 264-272.
- Sanchez-Hernandez, J. C. (2010). Environmental applications of earthworm esterases in the agroecosystem. *Journal of Pesticide Science*, 35, 290-301.
- Satoh, T. & Hosokawa, M. (2006). Structure, function and regulation of carboxylesterases. *Chemico-Biological Interactions*, 162, 195-211.
- Scheu, S. (2003). Effects of earthworms on plant growth: patterns and perspectives. *Pedobiologia*, 47, 846-856.

- Scott, G. R. & Sloman, K. A. (2004). The effects of environmental pollutants on complex fish behaviour: integrating behavioural and physiological indicators of toxicity. *Aquatic Toxicology*, 68, 369-392.
- Sogorb, M. A. & Vilanova, E. (2002). Enzymes involved in the detoxification of organophosphorus, carbamate and pyrethroid insecticides through hydrolysis. *Toxicology Letters*, 128, 215-228.
- Sorensen, F. F., Bayley, M. & Baatrup, E. (1995). The effects of sublethal dimethoate exposure on the locomotor behavior of the collembolan *Folsomia candida* (isotomidae). *Environmental Toxicology and Chemistry*, 14, 1587-1590.
- Spivak, M., Mader, E., Vaughan, M. & Euliss, N. H. (2011). The plight of the bees. *Environmental Science and Technology*, 45, 34-38.
- Stenersen, J. (1980). Esterases of earthworms. Part I: characterisation of the cholinesterases in *Eisenia foetida* (Savigny) by substrates and inhibitors. *Comparative Biochemistry and Physiology*, 66C, 37-44.
- Stenersen, J. (1984). Detoxication of xenobiotics by earthworms. *Comparative Biochemistry and Physiology*, 78C, 249-252.
- Thompson, C. M. & Richardson, R. J. (2004). Anticholinesterase insecticides, In: *Pesticide Toxicology and International Regulation*, Marrs, T. C. & Ballantyne, B. (Eds.), 89-127, John Wiley & Sons, West Sussex, England.
- van der Oost, R., Beyer, J. & Vermeulen, N. P. E. (2003). Fish bioaccumulation and biomarkers in environmental risk assessment: a review. *Environmental Toxicology and Pharmacology*, 13, 57-149.
- van Erp, S., Booth, L., Gooneratne, R. & O'Halloran, K. (2002). Sublethal responses of wolf spiders (Lycosidae) to organophosphorous insecticides. *Environmental Toxicology*, 17, 449-456.
- van Gestel, C. A. M. & van Brummelen, T. C. (1996). Incorporation of the biomarker concept in ecotoxicology calls for a redefinition of terms. *Ecotoxicology*, 5, 217-225.
- Walker, C.H., Hopkin, S.P., Sibly, R.M., Peakall, D.B. (2001). Principles of Ecotoxicology, 2nd ed. Taylor & Francis, London, United Kingdom.
- Wheelock, C., Eder, K., Werner, I., Huang, H., Jones, P., Brammell, B., Elskus, A. & Hammock, B. (2005). Individual variability in esterase activity and CYP1A levels in Chinook salmon (*Oncorhynchus tshawytscha*) exposed to esfenvalerate and chlorpyrifos. *Aquatic Toxicology*, 74, 172-192.
- Wheelock, C. E., Wheelock, A. M., Zhang, R., Stok, J. E., Morisseau, C., Le Valley, S. E., Green, C. E. & Hammock, B. D. (2003). Evaluation of  $\alpha$ -cyanoesters as fluorescent substrates for examining interindividual variation in general and pyrethroid-selective esterases in human liver microsomes. *Analytical Biochemistry*, 315, 208-222.
- Wheelock, C. E., Shan, G. & Ottea, J. (2005). Overview of carboxylesterases and their role in the metabolism of insecticides. *Journal of Pesticide Science*, 30, 75-83.
- Wheelock, C. E., Phillips, B. M., Anderson, B. S., Miller, J. L., Miller, M. J. & Hammock, B. D. (2008). Applications of carboxylesterase activity in environmental monitoring and toxicity identification evaluations (TIEs). *Reviews of Environmental Contamination and Toxicology*, 195, 117-178.

- Whyte, J. J., Jung, R. E., Schmitt, C. J. & Tillitt, D. E. (2000). Ethoxyresorufin-O-deethylase (EROD) activity in fish as a biomarker of chemical exposure. *Critical Reviews in Toxicology*, 30, 347-570.
- Wogram, J., Sturm, A., Segner, H. & Liess, M. (2001). Effects of parathion on acetylcholinesterase, butyrylcholinesterase, and carboxylesterase in three-spined stickleback (*Gasterosteus aculeatus*) following short-term exposure. *Environmental Toxicology and Chemistry*, 20, 1528-1531.
- Yu, S. J., Robinson, F. A. & Nation, J. L. (1984). Detoxication capacity in the honey bee, *Apis mellifera* L. *Pesticide Biochemistry and Physiology*, 22, 360-368.

IntechOpen

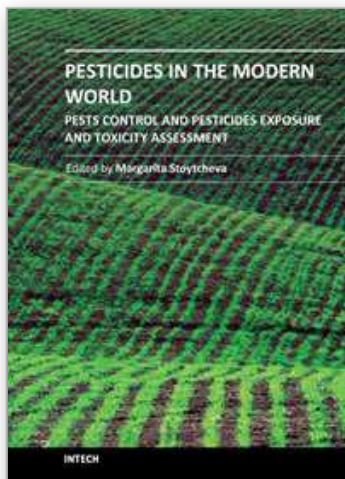

**Pesticides in the Modern World - Pests Control and Pesticides Exposure and Toxicity Assessment**

Edited by Dr. Margarita Stoytcheva

ISBN 978-953-307-457-3

Hard cover, 614 pages

**Publisher** InTech

**Published online** 30, September, 2011

**Published in print edition** September, 2011

The present book is a collection of selected original research articles and reviews providing adequate and up-to-date information related to pesticides control, assessment, and toxicity. The first section covers a large spectrum of issues associated with the ecological, molecular, and biotechnological approaches to the understanding of the biological control, the mechanism of the biocontrol agents action, and the related effects. Second section provides recent information on biomarkers currently used to evaluate pesticide exposure, effects, and genetic susceptibility of a number of organisms. Some antioxidant enzymes and vitamins as biochemical markers for pesticide toxicity are examined. The inhibition of the cholinesterases as a specific biomarker for organophosphate and carbamate pesticides is commented, too. The third book section addresses to a variety of pesticides toxic effects and related issues including: the molecular mechanisms involved in pesticides-induced toxicity, fish histopathological, physiological, and DNA changes provoked by pesticides exposure, anticoagulant rodenticides mode of action, the potential of the cholinesterase inhibiting organophosphorus and carbamate pesticides, the effects of pesticides on bumblebee, spiders and scorpions, the metabolic fate of the pesticide-derived aromatic amines, etc.

**How to reference**

In order to correctly reference this scholarly work, feel free to copy and paste the following:

Juan C. Sanchez-Hernandez (2011). Pesticide Biomarkers in Terrestrial Invertebrates, Pesticides in the Modern World - Pests Control and Pesticides Exposure and Toxicity Assessment, Dr. Margarita Stoytcheva (Ed.), ISBN: 978-953-307-457-3, InTech, Available from: <http://www.intechopen.com/books/pesticides-in-the-modern-world-pests-control-and-pesticides-exposure-and-toxicity-assessment/pesticide-biomarkers-in-terrestrial-invertebrates>

**INTECH**  
open science | open minds

**InTech Europe**

University Campus STeP Ri  
Slavka Krautzeka 83/A  
51000 Rijeka, Croatia  
Phone: +385 (51) 770 447  
Fax: +385 (51) 686 166  
[www.intechopen.com](http://www.intechopen.com)

**InTech China**

Unit 405, Office Block, Hotel Equatorial Shanghai  
No.65, Yan An Road (West), Shanghai, 200040, China  
中国上海市延安西路65号上海国际贵都大饭店办公楼405单元  
Phone: +86-21-62489820  
Fax: +86-21-62489821

© 2011 The Author(s). Licensee IntechOpen. This chapter is distributed under the terms of the [Creative Commons Attribution-NonCommercial-ShareAlike-3.0 License](#), which permits use, distribution and reproduction for non-commercial purposes, provided the original is properly cited and derivative works building on this content are distributed under the same license.

IntechOpen

IntechOpen