

We are IntechOpen, the world's leading publisher of Open Access books Built by scientists, for scientists

4,800

Open access books available

122,000

International authors and editors

135M

Downloads

Our authors are among the

154

Countries delivered to

TOP 1%

most cited scientists

12.2%

Contributors from top 500 universities



WEB OF SCIENCE™

Selection of our books indexed in the Book Citation Index
in Web of Science™ Core Collection (BKCI)

Interested in publishing with us?
Contact book.department@intechopen.com

Numbers displayed above are based on latest data collected.

For more information visit www.intechopen.com



Optimal Location and Control of Flexible Three Phase Shunt FACTS to Enhance Power Quality in Unbalanced Electrical Network

Belkacem Mahdad

*Department of Electrical Engineering, Biskra University
Algeria*

1. Introduction

The problem of voltage or current unbalance is gaining more attention recently with the increasing awareness on power quality. Excessive unbalance among the phase voltages or currents of a three phase power system has always been a concern to expert power engineers. An unbalanced voltage supply can cause power electronic converters to generate more harmonic distortions. It may result in the malfunction of sensitive three-phase electronic equipment. In fact, the voltage and current unbalance has been regarded as one of the basic power quality attributes (Birt et al., 1976).

The asymmetry in transmission lines and loads produces a certain degree of unbalance in real power systems. Under these conditions, low quantities of negative and zero sequence voltages can be observed in power networks. These magnitudes are considered to be a disturbance whose level must be controlled by power quality standards to maintain the electromagnetic compatibility of the system (Mamdouh Abdel-Akher et.al, 2005).

In order to cope with these kind of problems and increase usable power transmission capacity, Flexible AC transmission systems (FACTS), where developed and introduced to the market. FACTS philosophy was first introduced by Hingorani (Hingorani, N.G, 1988) from the Electric power research institute (EPRI). The objective of FACTS devices is to bring a system under control and to transmit power as ordered by the control centers, it also allows increasing the usable transmission capacity to its thermal limits. With FACTS devices we can control the phase angle, the voltage magnitude at chosen buses and/or line impedances (Mahdad.b et al., 2006)

In practical installation of FACTS in power system, there are six common requirements as follows (Mahdad.b et al., 2007) :

1. What Kinds of FACTS devices should be installed?
2. Where in the system should be placed?
3. How much capacity should it have?
4. How to coordinate dynamically the interaction between multiple FACTS and the network to better exploit FACTS devices?
5. How to estimate economically the optimal size and number of FACTS to be installed in a practical network?
6. How to adjust dynamically the three phase relative power in unbalanced network?

Recent developments and research indicate clearly that artificial intelligence techniques like fuzzy logic (Tmsovic, 1992), (Su, C. T. et al., 1996), Artificial Neural Network (Scala et al., 1996), and expert system (Bansilal et al., 1997) may be useful for assisting experienced planning engineers in energy centre dispatch. In recent years many interesting applications of fuzzy systems to reactive power planning and voltage control have been developed and applied in practical power system distribution. (Udupa et al., 1999) presented approach based in fuzzy set theory for reactive power control with purpose to improve voltage stability of power system. (Su et al., 1996) presented a knowledge-based system for supervision and control of regional voltage profile and security using fuzzy logic.

In the literature, many applications for optimal placement and control of FACTS devices are developed using the positive-sequence power systems. The application of these methods for unbalanced power systems may be unrealistic and could not be able to characterize accurately the real behaviour of the unbalanced distribution system.

One of the main tasks of a planning engineers in electricity distribution system is to ensure that network parameters, such as bus voltages, and line load, are maintained within predefined limits (desired value). This chapter tries to give answers to the following important questions:

- How an experienced planning engineers can choose efficiently locations and coordination of multiple shunt FACTS devices (SVC, STATCOM) in unbalanced practical network which are probably high suitable?
- How they can exploit efficiently the performance of these devices without violating the constraints limits?

Static Var Compensator (SVC) is one of the key elements in power system that provides the opportunity to improve power quality. This chapter presents a methodology that coordinate the expertise of power system engineer formulated in flexible fuzzy rules to adjust dynamically the reactive power compensation based three phase model shunt FACTS controller installed at critical buses. The main target of this proposed technique is to reduce the asymmetrical voltage and to enhance the system loadability with consideration of unbalanced electrical network. The proposed approach has been tested on a variety of electrical network 5-Bus, IEEE 30-Bus. Testing results indicate clearly that the proposed approach based in asymmetrical compensation reduces the effect of asymmetrical voltage in distribution power system and improve the indices of power quality.

2. Flexible AC Transmission Systems (FACTS) technology

The objective of FACTS technology is to bring a system under control and to transmit power as ordered by the control centre, it also allows increasing the usable transmission capacity to its maximum thermal limits.

The central technology of FACTS involves high power electronics, a variety of thyristor devices, microelectronics, communications and advanced control centres. Power flow through an ac line is a function of phase angle, line end voltages and line impedance, and there is little or no control over any of these variables. The consequences of this lack of fast, reliable control and stability problems, power flowing through other than the intended lines, the inability to fully utilize the transmission resources, undesirable Var flows, higher losses, high or low voltages, cascade tripping and long restoration time. With FACTS devices we can control the phase angle, the voltage magnitude at chosen buses and/or line impedances. Power flow is electronically controlled and it flows as ordered by the control centre (Mahdad. B, 2010).

2.1 Basic types of FACTS controllers

In general, FACTS Controllers can be divided into three categories (Hingorani et al., 1999):

- Series Controllers
- Shunt Controllers
- Combined series-series Controllers

2.2 Role of FACTS controllers

The following points summarize the objectives of FACTS devices in power system control and operation:

- Control of power flow as ordered
- Increase the loading capability of lines to their thermal capabilities
- Increase the reliability and system security through raising the transient stability limit, limiting short-circuit currents and overloads, managing cascading blackouts
- Provide greater flexibility in sitting new generation
- Reduce reactive power flows, thus allowing the lines to carry more active power
- Reduce loop flows.
- Enhance the economic dispatch of generating units.

2.3 Three phase static var compensator modelling

Model presented by (Acha et.al, 2004), is based on the concept of a variable susceptance B_k^{pq} , which adjust itself in order to constrain the nodal voltage magnitude. This changing susceptance represents the total equivalent susceptance of all modules making up the SVC, independently of their operating mode and electric characteristics. Based on Fig. 1, the SVC transfer admittance equation expressed as follows:

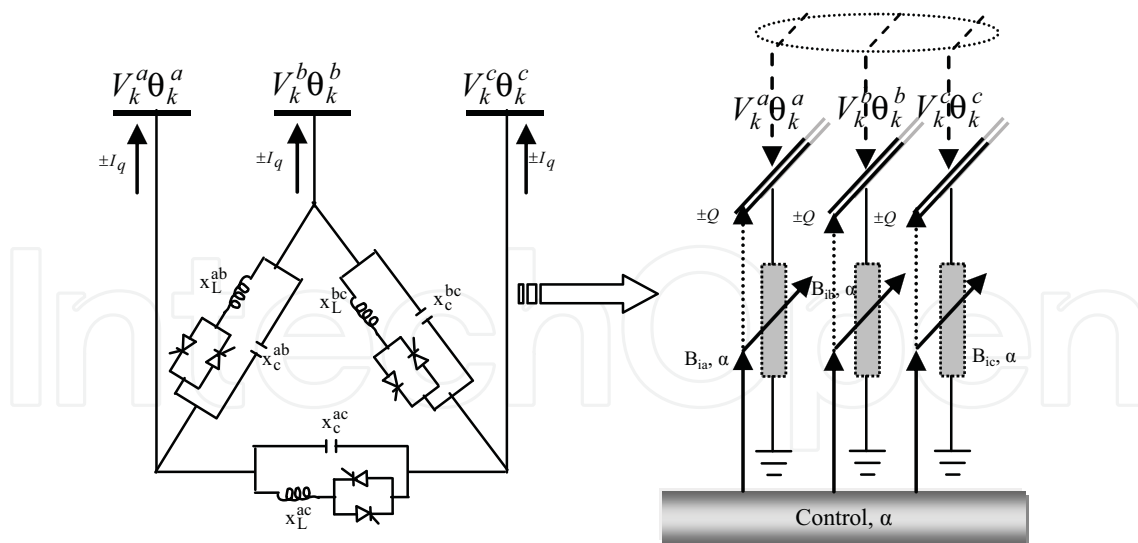

Fig. 1. SVC based on FC-TCR modules in delta-connected arrangement

$$\begin{bmatrix} I_k^a \\ I_k^b \\ I_k^c \end{bmatrix} = j \begin{bmatrix} B_k^{ab} + B_k^{ca} & -B_k^{ab} & B_k^{ca} \\ -B_k^{ab} & B_k^{ab} + B_k^{bc} & -B_k^{bc} \\ -B_k^{ca} & -B_k^{bc} & B_k^{bc} - B_k^{ca} \end{bmatrix} \begin{bmatrix} V_k^a \\ V_k^b \\ V_k^c \end{bmatrix} \quad (1)$$

A three-phase SVC model presented by (Acha, et al. 2004) is implemented and adapted within the proposed algorithm to regulate and control the reactive power injected or absorbed in the unbalanced three phase power systems. As shown in Fig. 1, every branch has a fixed capacitor and a thyristor-controlled capacitor reactor. Equation (2) is the equivalent susceptance or admittance of each branch by controlling the firing delays angles (α) of thyristor.

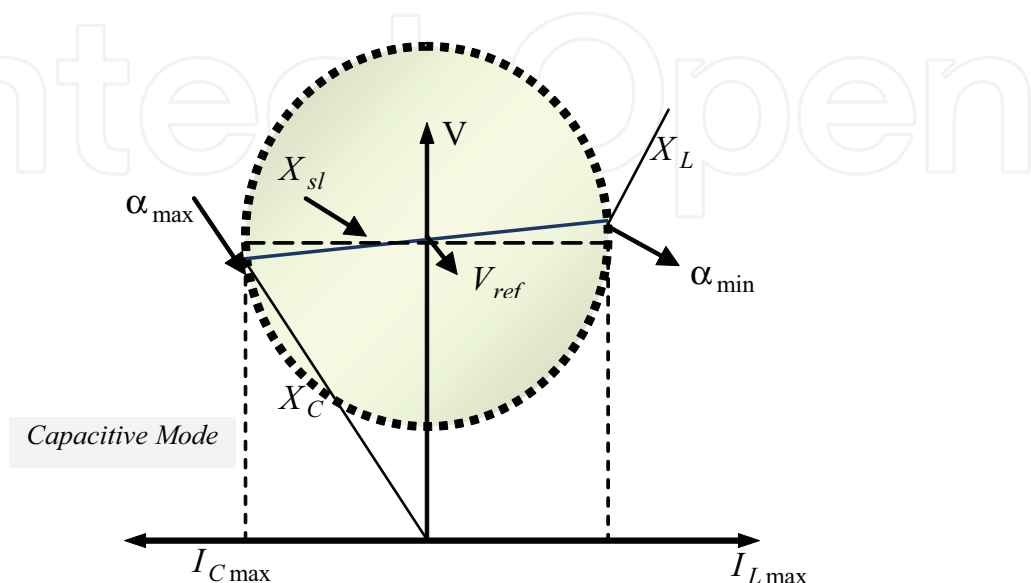

Fig. 2. Typical steady state V-I Characteristics of SVC

$$B_{TCR}^{pq} = \frac{2(\pi - \alpha_{TCR}^{pq}) - \sin 2\alpha_{TCR}^{pq}}{\pi\omega L_{TCR}^{pq}} \quad (2)$$

The superscripts p, q correspond to phases a, b and c.

The steady-state control law for the SVC is the typical current-voltage characteristic, illustrated in Fig. 2.

2.4 Three-phase power flow equation

The network branch modelling in unbalanced multi-wire distribution systems is typically done and simplified using the Carson's equations to self and the mutual impedances, and by applying the kron reduction to determine the reduced impedance matrix Z_{abc} of each branch, referred to the phases a, b and c.

The power-flow equations at buses k and m based on Fig. 3 may be given by:

$$P_k^p = V_k^p \left\{ \sum_{i=k,m} \sum_{j=a,b,c} V_i^j \left[G_{ki}^{pj} \cos(\theta_k^p - \theta_i^j) + B_{ki}^{pj} \sin(\theta_k^p - \theta_i^j) \right] \right\}, \quad (3)$$

$$Q_k^p = V_k^p \left\{ \sum_{i=k,m} \sum_{j=a,b,c} V_i^j \left[G_{ki}^{pj} \sin(\theta_k^p - \theta_i^j) - B_{ki}^{pj} \cos(\theta_k^p - \theta_i^j) \right] \right\}, \quad (4)$$

Where the subscript k, m represent the bus number while the subscript p represent the phase a, b and c.

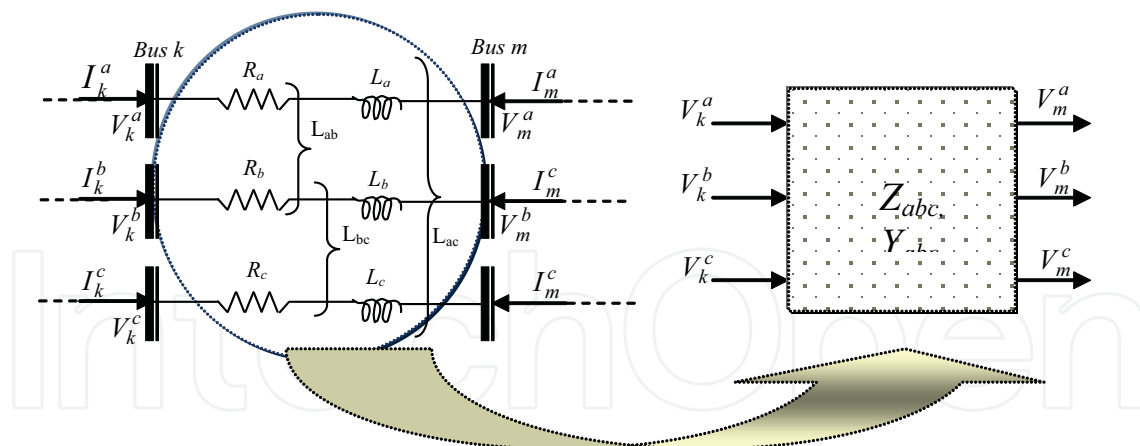

Fig. 3. Representation of a branch reduced to the three-phase branch impedance matrix

The power mismatch equations at buses may be given by:

$$\Delta P_k^p = -Pd_k^p + P_k^p = 0 \tag{5}$$

$$\Delta Q_k^p = -Qd_k^p + Q_k^p = 0 \tag{6}$$

Where Pd_m^p and Qd_m^p are the active and reactive load powers of phase p at bus m, respectively. P_k^p and Q_k^p , which are given by (3) and (4), are the sum of the active and reactive power flows of phase p at bus m, respectively.

In the following, the three-phase Newton power flow algorithm in polar coordinates, which is similar to that proposed in (Acha, et al. 2004), will be described. the non-linear equations can be combined and expressed in compact form.

$$f(x) = 0 \tag{7}$$

Where, $f(x) = 0$ represents the whole set of power-flow mismatch and machine terminal constraint equations, x is the state variable vector and given by

$$x = [\theta^a, V^a, \theta^b, V^b, \theta^c, V^c, \delta^a, E^a]^t \tag{8}$$

The Newton equation is given by

$$J(x)\Delta x = -f(x) \tag{9}$$

Where, $J(x) = \partial f(x) / \partial x$ is the system Jacobian matrix.

The resulting linearised equation, suitable for iterative solutions, becomes:

$$\begin{bmatrix} \Delta P_l^p \\ \Delta Q_l^p \end{bmatrix}^i = \begin{bmatrix} \frac{\partial P_l^p}{\partial \theta_j^p} & \frac{\partial P_l^p}{\partial V_j^p} V_j^p \\ \frac{\partial Q_l^p}{\partial \theta_j^p} & \frac{\partial Q_l^p}{\partial V_j^p} V_j^p \end{bmatrix}^i \begin{bmatrix} \Delta \theta_j^p \\ \frac{\Delta V_j^p}{V^p} \end{bmatrix} \tag{10}$$

Where $l=k, m, j=k, m$ and (i) is the iteration number.

3. Dynamic strategy for asymmetric control of multiple shunt compensator

One of the principal tasks of the operator of an electricity distribution system is to ensure that network parameters, such as bus voltages and line load, are maintained within predefined limits. The problem of system imbalance has considerable effects on power systems. The effects of zero sequence current on protection relays and negative sequence current on motors are well known by power engineers (Mahdad.b et al., 2006). However, others effects such as increasing system loss, decreasing system capacity, and increasing the inductive coupling between parallel lines or feeders are often overlooked.

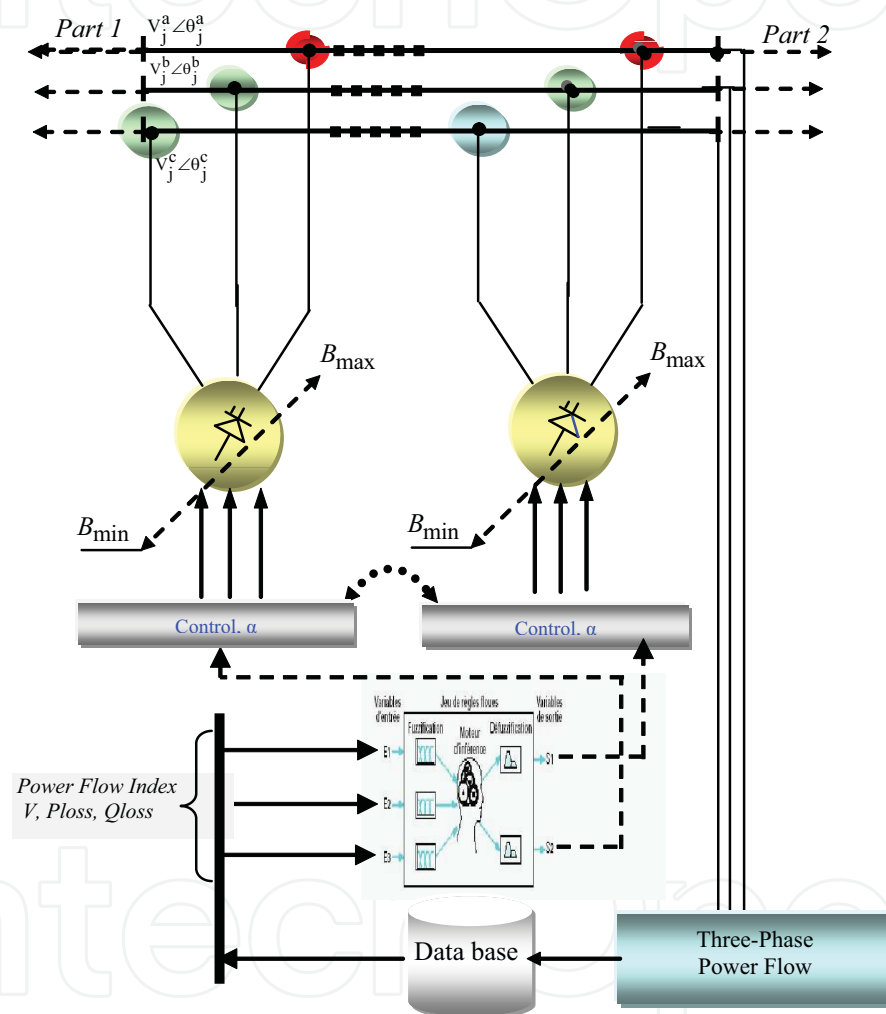

Fig. 4. A global block control strategy

The intensive use of FACTS devices in the emerging electricity market environment demands more robust and online FACTS control methodologies.

The main objective of this section is to formulate the basic idea behind the proposed approach.

3.1 Practical experience rules and fuzzy logic

A review of the literature on reactive power compensation in distribution feeders indicates that the problem of capacitors Allocation has been extensively researched over the past

several decades (Mahdad.b et al., 2007). The solution techniques for the reactive power planning problem can be classified into three categories:

- Analytical,
- numerical programming, heuristics,
- and artificial intelligence based.

The choice of which method to use depends on: the problem to be solved, the complexity of the problem, the accuracy of desired results. Once these criteria are determined, the appropriate capacitor Allocation techniques can be chosen.

The use of fuzzy logic has received increased attention in recent years because of it's usefulness in reducing the need for complex mathematical models in problem solving (Mahdad.b, 2010).

Fuzzy logic employs linguistic terms, which deal with the causal relationship between input and output variables. For this reason the approach makes it easier to manipulate and solve problems.

So why using fuzzy logic in Reactive Power Planning and coordination of multiple shunt FACTS devices?

- Fuzzy logic is based on natural language.
- Fuzzy logic is conceptually easy to understand.
- Fuzzy logic is flexible.
- Fuzzy logic can model nonlinear functions of arbitrary complexity.
- Fuzzy logic can be blended with conventional control techniques.

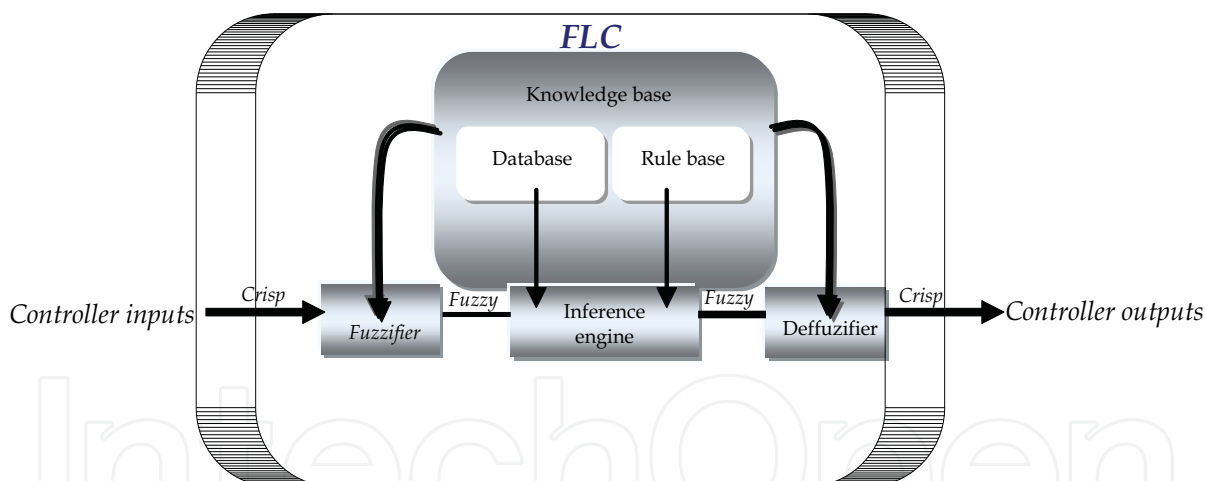

Fig. 5. Schematic diagram of the FLC building blocks

It is intuitive that a section in a distribution system with high losses and low voltage is ideal for installation of facts devices, whereas a low loss section with good voltage is not. Note that the terms, high and low are linguistic.

3.2 Membership function

A membership function use a continuous function in the range [0-1]. It is usually decided from humain expertise and observations made and it can be either linear or non-linear. The basic mechanism search of fuzzy logic controller is illustrated in Fig. 5.

It choice is critical for the performance of the fuzzy logic system since it determines all the information contained in a fuzzy set. Engineers experience is an efficient tool to achieve a

design of an optimal membership function, if the expert operator is not satisfied with the conception of fuzzy logic model, he can adjust the parameters used to the design of the membership functions to adapt them with new database introduced to the practical power system. Fig. 6 shows the general bloc diagram of the proposed coordinated fuzzy approach applied to enhance the system loadability in an Unbalanced distribution power system.

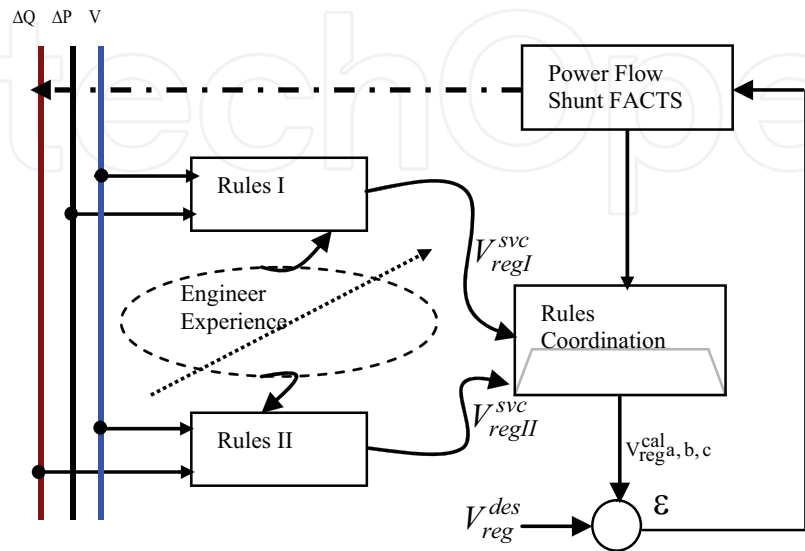

Fig. 6. General schematic diagram of the proposed coordinated fuzzy approach

		Phase a				} $Q_{svc}^p = \begin{bmatrix} Q_{svc}^a \\ Q_{svc}^b \\ Q_{svc}^c \end{bmatrix}^{Step1}$
		VL	L	M	H	
$Q_{svc}^{(a)}$		VL	L	M	H	
		Phase b				
		VL	L	M	H	
$Q_{svc}^{(b)}$		VL	L	M	H	
		Phase c				
		VL	L	M	H	
$Q_{svc}^{(c)}$		VL	L	M	H	

Where; Q_{svc}^p , reactive power for three phase.

The solution algorithm steps for the fuzzy control methodology are as follows:

1. Perform the initial operational three phase power flow to generate the initial database $(V_i^p, \Delta P_i^p, \Delta Q_i^p)$.
2. Identify the candidate bus using continuation load flow.
3. Identify the candidate phase for all bus $(\min V_i^p)$.
4. Install the specified shunt compensator to the best bus chosen, and generate the reactive power using three phase power flow based in fuzzy expert approach:

a. Combination Active and Reactive Power Rules. Fig. 7.

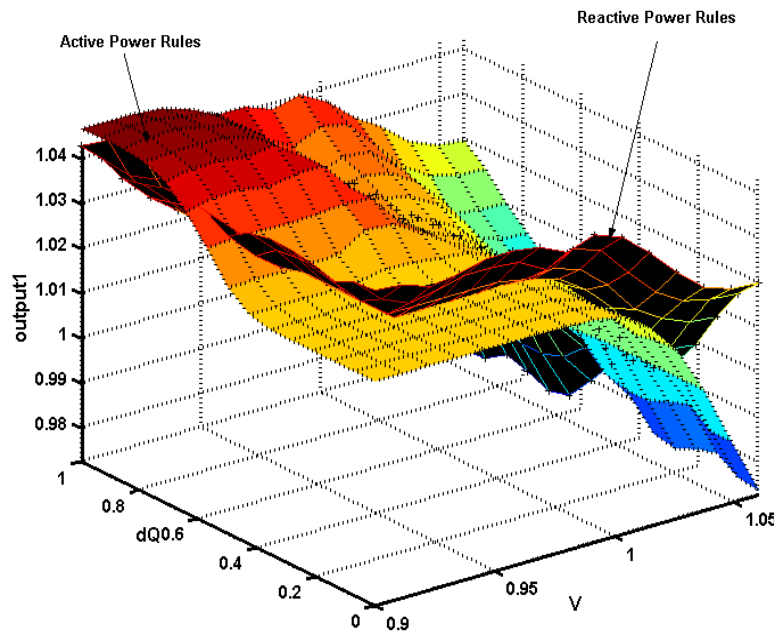

Fig. 7. Combination voltage, active and reactive power rules

b. Heuristic Strategy Coordination

- If $\tau_a = \tau_b = \tau_c$ which correspond to the balanced case, where τ_a, τ_b, τ_c the degree of unbalance for each phase compared to the balanced case. In this case, $(Q_{svc}^a = Q_{svc}^b = Q_{svc}^c)$.
- If $\tau_c > \tau_b > \tau_a$ then increment Q_{svc}^c , while keeping Q_{svc}^b, Q_{svc}^a fixed. Select the corrected value of Q_{svc}^c which verify the following conditions:

$$\tau_{tot} \leq \tau_{des}$$

and $\Delta P_{asy} \leq \Delta P_{bal}$

where τ_{tot} represent the maximum degree of unbalance.

τ_{des} the desired degree of unbalance.

ΔP_{asy} power loss for the unbalanced case.

ΔP_{bal} power loss for the balanced case.

5. If the maximum degree of unbalance is not acceptable within tolerance (desired value based in utility practice). Go to step 4.
6. Perform the three phase load flow and output results.

3.3 Minimum reactive power exchanged

The minimum reactive power exchanged with the network is defined as the least amount of reactive power needed from network system, to maintain the same degree of system security margin. One might think that the larger the SVC or STATCOM, the greater increase in the maximum load, based in experience there is a maximum increase on load margin with respect to the compensation level (Mahdad.b et al., 2007).

In order to better, evaluate the optimal utilization of SVC and STATCOM we introduce a supplementary rating level, this technical ratio shows the effect of the shunt dynamic compensator Mvar rating in the maximum system load, therefore, a maximum value of this factor yields the optimal SVC and STATCOM rating, as this point correspond to the maximum load increase at the minimum Mvar level.

This index is defined as:

$$RIS^{(\rho)} = \frac{LoadFactor(KLd)}{\sum_{i=1}^{N_{sh}} Q_{Shunt}^{(\rho)}} \quad (11)$$

where: N_{sh} is the number of shunt compensator

Kld: Loading Factor.

$Q_{Shunt}^{(\rho)}$: Reactive power exchanged (absorbed or injected) with the network at phase ρ (a, b, c).

ρ Index of phase, a, b, c.

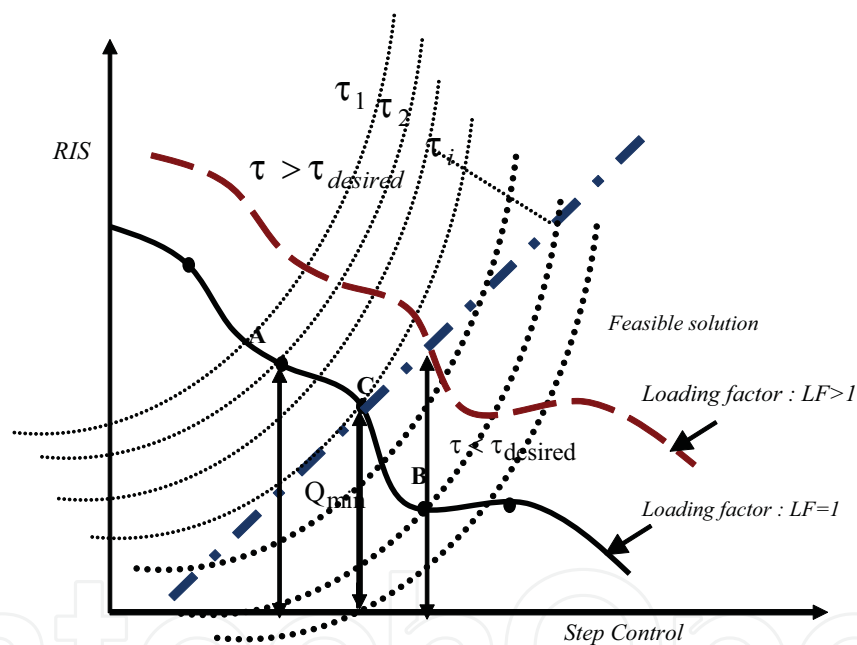

Fig. 8. Schematic diagram of reactive power index sensitivity

Fig. 8 shows the principle of the proposed reactive index sensitivity to improve the economical size of shunt compensators installed in practical network. In this figure, the curve represents the evolution of minimum reactive exchanged based in system loadability, the curve has two regions, the feasible region which contains the feasible solution of reactive power. At point 'A', if the SVC outputs less reactive power than the optimal value such as at point 'B', it has a negative impact on system security since the voltage margin is less than the desired margin, but the performances of SVC Compensator not violated. On the other hand, if the SVC produces more reactive power than the minimum value (Q_{min}), such as point 'C', it contributes to improving the security system with a reduced margin of system loadability, this reactive power delivered accelerates the saturation of the SVC Controllers.

4. Numerical results

In this section, numerical results are carried out on simple network, 5-bus system and IEEE 30-bus system. The solution was achieved in 4 iterations to a power mismatch tolerance of $1e-4$.

4.1 Case studies on the 5-bus system

The following cases on the 5-bus network have been studied:

Case1: Balanced network and the whole system with balanced load.

The results given in Table. 1 are identical with those obtained from single-phase power flow programs. The low voltage is at bus 5 with 0.9717 p.u, the power system losses are 6.0747 MW. Neither negative nor zero sequence voltages exist.

Bus	Phase A (p.u)		Phase B (p.u)		Phase C (p.u)	
1	1.06	0	1.06	240	1.06	120
2	1	-2.0610	1	237.9390	1	117.9390
3	0.9873	-4.6364	0.9873	235.3636	0.9873	115.3636
4	0.9841	-4.9567	0.9841	235.0433	0.9841	115.0433
5	0.9717	-5.7644	0.9717	234.2356	0.9717	114.2356

Total Power Losses 6.0747 (MW)

Table 1. Three-phase bus voltages for the balanced case. 1

Case2: Balanced network and the whole system with unbalanced load.

4.1.1 Optimal placement of shunt FACTS based voltage stability

Before the insertion of SVC devices, the system was pushed to its collapsing point by increasing both active and reactive load discretely using three phase continuation load flow (Mahdad.b et al., 2006). In this test system according to results obtained from the continuation load flow, we can find that based in Figs. 9, 10, 11 that bus 5 is the best location point.

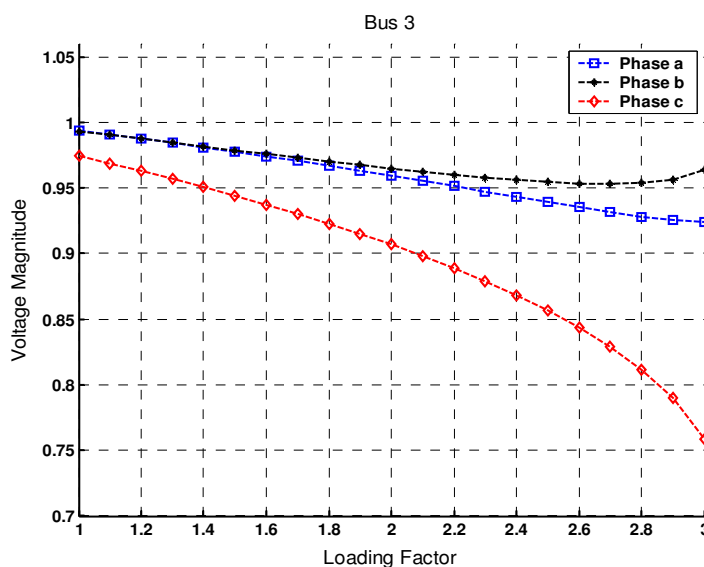

Fig. 9. Three phase voltage solution at bus 3 with load Incrementation

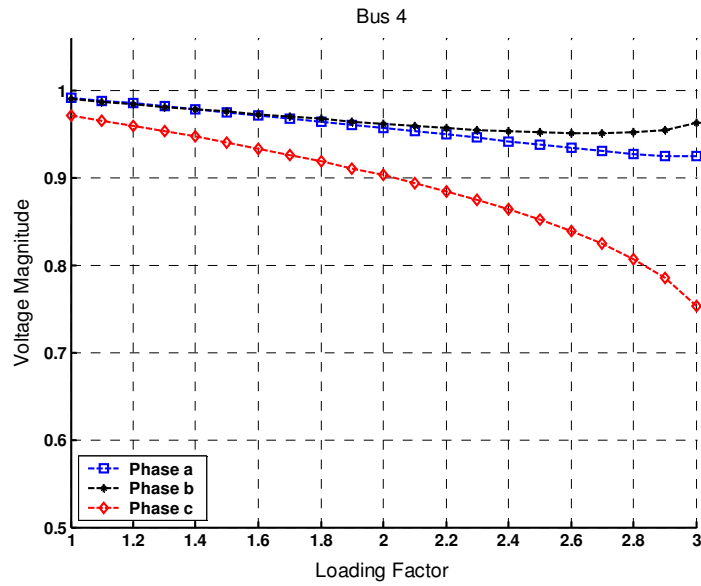

Fig. 10. Three phase voltage solution in bus 4 with load Incrementation

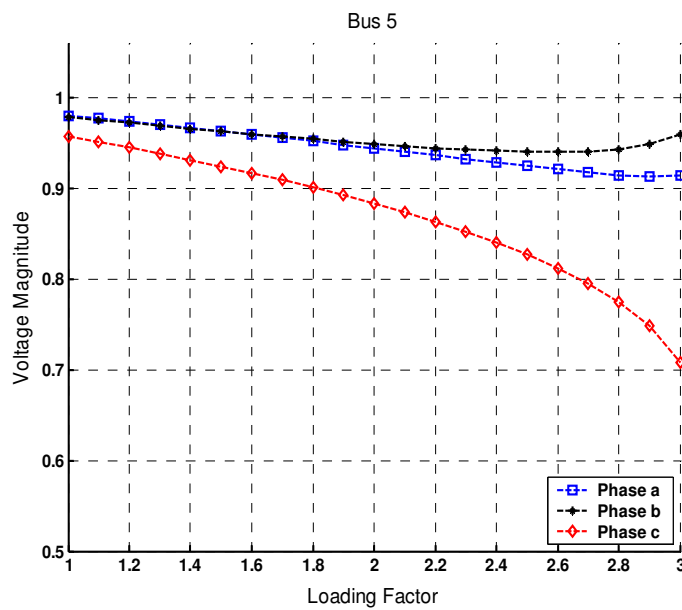

Fig. 11. Three phase voltage solution in bus 5 with load Incrementation

To affirm these results we suppose the SVC with technical values indicated in Table. 2 installed on a different bus. Figs. 9-10-11, show the three phase voltage solution at different buses with load Incrementation. Fig. 12 shows the variation of negative sequence voltage in bus 3, 4, 5 with load incrementation.

	Bmin (p.u)	Bmax (p.u)	Binit (p.u)
Susceptance Model One SVC	-0.35	0.35	0.025
Susceptance Model Multi-SVC	-0.25	0.25	0.020

Table 2. SVCs data

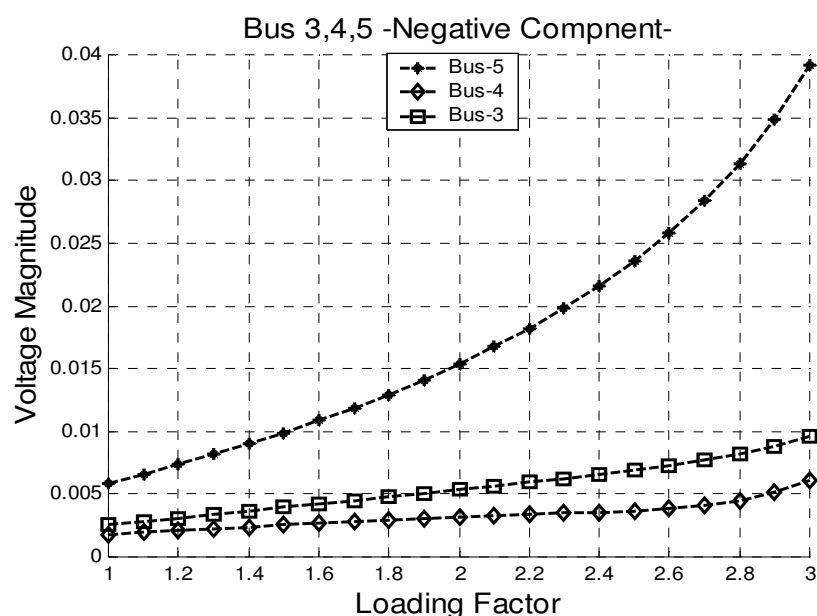

Fig. 12. Negative sequence voltage in bus 3-4-5 with load incrementation

Case2: Unbalanced Load Without Compensation

Table. 3 shows the three phase voltage solution for unbalanced load, the impact of unbalanced load on system performance can be appreciated by comparing the results given in Table. 3 -4 and Table.1, where small amounts of negative and zero sequence voltages appeared. In this case the low voltage appeared in bus 5 with 0.9599 p.u at phase 'c' which is lower than the balanced case, the system power losses are incremented to 6.0755 MW with respect to the balanced case. Table. 4 shows the results of power flow for the unbalanced power system, it can be seen from results that all three phases are unbalanced.

Bus	Phase A	Phase B	Phase C	V-
1	1.06	1.06	1.06	/
2	1	1	1	/
3	0.9820	0.9881	0.9908	0.0026
4	0.9811	0.9831	0.9872	0.0018
5	0.9789	0.9755	0.9599	0.0059

Total Power Loss 6.0755 (MW)

Table 3. Three-phase bus voltages for the unbalanced case.2

Bus	Phase A	Phase B	Phase C	V-
1	1.06	1.06	1.06	/
2	1	1	1	/
3	1.0013	0.9995	0.9608	0.0132
4	0.9991	0.9963	0.9569	0.0136
5	0.9887	0.9848	0.9419	0.0150

Total Power Loss (MW) 6.0795

Table 4. Three phase bus voltages for the unbalanced case.2: other degree of unbalance

Case 3: Unbalanced Load With Shunt Compensation based Fuzzy Rules

Figs 13, 14, 15, show the results of the application of the heuristic strategy coordinated with standard fuzzy rules to find the minimum efficient value of reactive power exchanged between shunt compensator (SVC) and the network needed to assure efficient degree of security. In Fig. 13, for one SVC installed at bus 5 and at the step control '10', the reactive power for the three phase $Q_{svc}^p = [0.0468 \ 0.0702 \ 0.1170]$ represent the minimum reactive power needed to assure the degree of system security margin. The low voltage appeared in bus 5 with 0.9720 p.u at phase 'c' which is higher than the case without compensation. Tables. 5-6-7-8, show the results of the three phase power flow solution for the unbalanced newtwork.

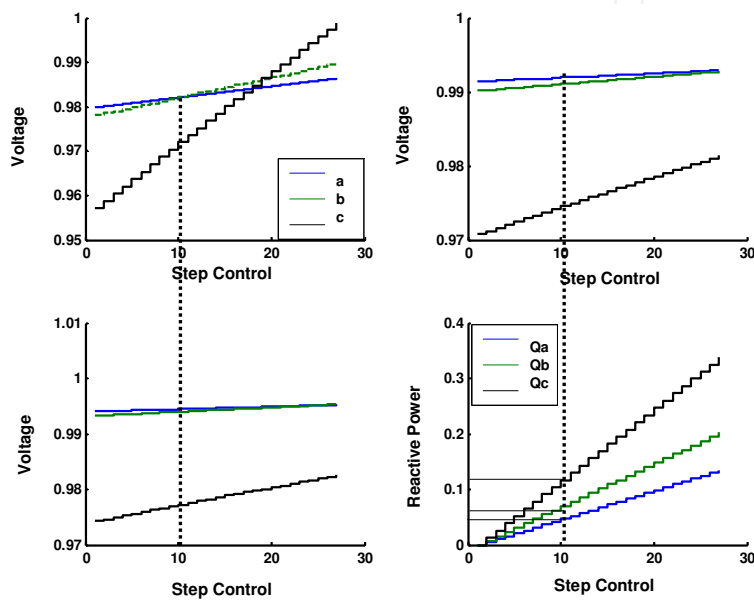

Fig. 13. Minimum reactive power exchanged with SVC installed at bus 5

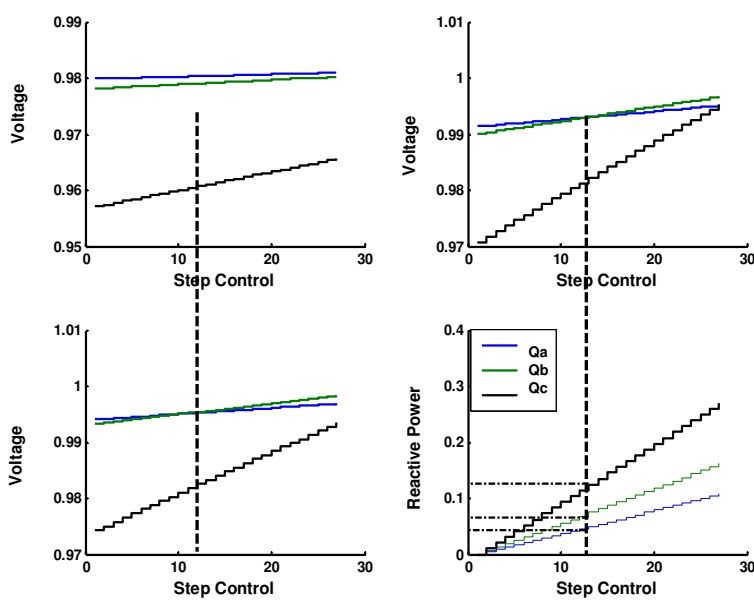

Fig. 14. Minimum reactive power exchanged with SVC installed at bus 4

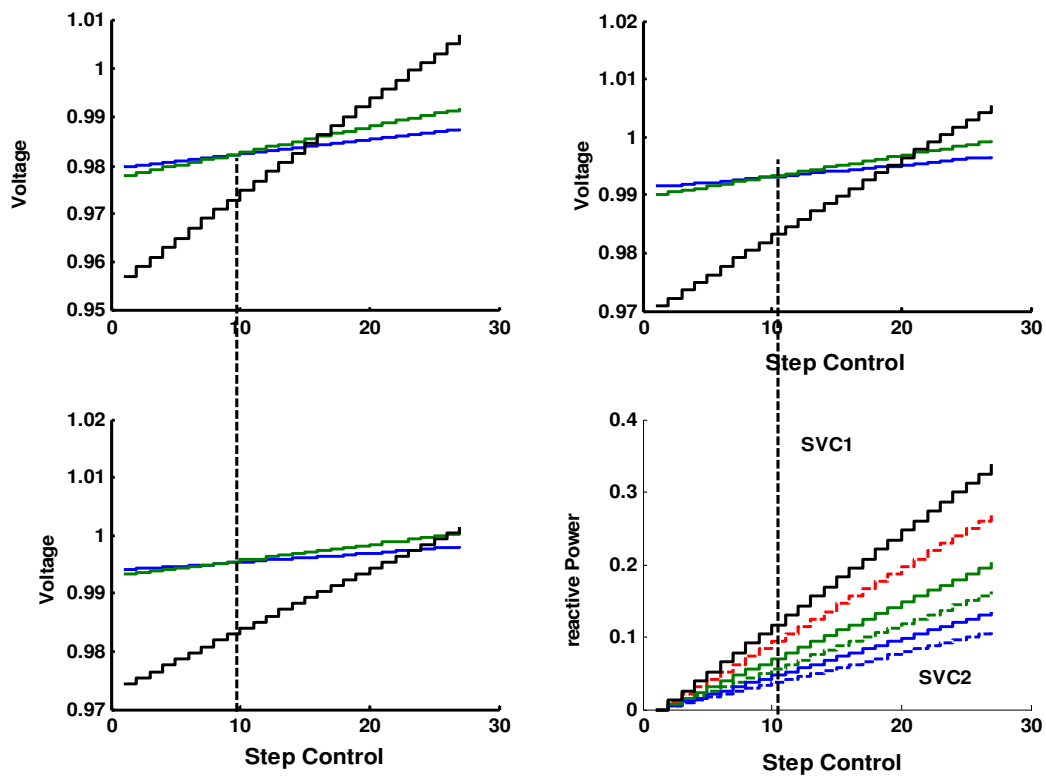

Fig. 15. Minimum reactive power exchanged with SVC installed at bus 4, 5

Bus	Phase A (p.u)	Phase B (p.u)	Phase C (p.u)	
3	0.9954	0.9956	0.9833	
4	0.9833	0.9932	0.9823	
5	0.9805	0.9791	0.9611	
Q_{svc}^p (p.u)	0.0499	0.0749	0.1248	
RIS^p (p.u)	7.0126	4.6729	2.8043	14.4898

Table 5. SVC installed at bus 4 ($k_a=1, k_b=0.9, k_c=1.1$, loading factor =1)

Bus	Phase A (p.u)	Phase B (p.u)	Phase C (p.u)	
3	0.9945	0.9940	0.9772	
4	0.9920	0.9911	0.9746	
5	0.9822	0.9822	0.9720	
Q_{svc}^p (p.u)	0.0468	0.0702	0.1170	
RIS^p (p.u)	7.4794	4.9850	2.9913	15.4557

Table 6. SVC installed at bus 5, step control '10' ($k_a=1, k_b=0.9, k_c=1.1$, loading factor=1)

Bus	Phase A (p.u)	Phase B (p.u)	Phase C (p.u)	
3	0.9948	0.9946	0.9798	
4	0.9924	0.9919	0.9778	
5	0.9842	0.9858	0.9848	
Q_{svc}^p (p.u)	0.0884	0.1326	0.2210	
RIS^p (p.u)	3.9588	2.6392	1.5838	8.1818

Table 7. SVC at bus 5, step control'18' (ka=1, kb=0.9, kc=1.1, loading factor=1)

Bus	Phase A (p.u)	Phase B (p.u)	Phase C (p.u)	
3	0.9953	0.9955	0.9829	
4	0.9930	0.9930	0.9818	
5	0.9823	0.9824	0.9730	
Q_{svc4}^p (p.u)	0.0416	0.0624	0.1040	
Q_{svc5}^p (p.u)	0.0374	0.0562	0.0936	
RIS_4^p (p.u)	6.0096	4.0064	2.4038	12.4198
RIS_5^p (p.u)	6.6845	4.4484	2.6709	13.8038

Table 8. SVC at bus 4 and bus 4, 5 (ka=1, kb=0.9, kc=1.1, loading factor=1)

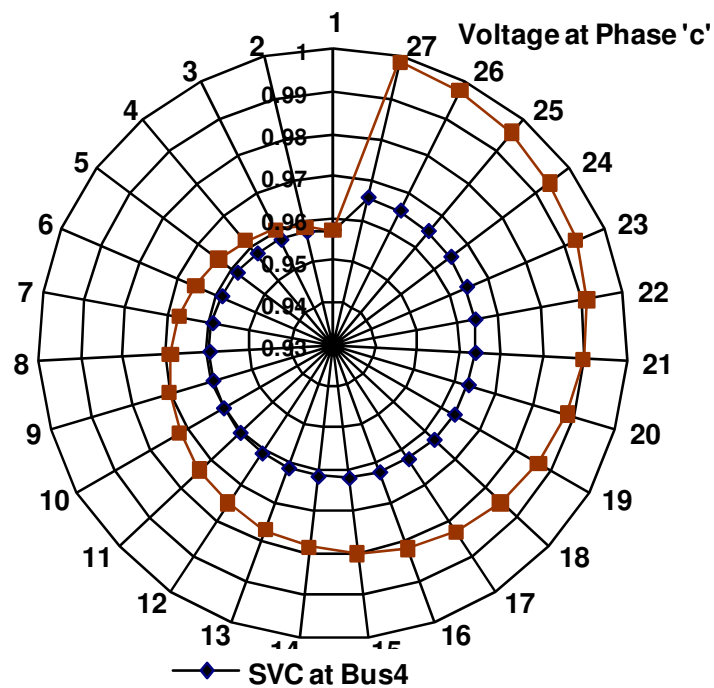

Fig. 16. Voltage profiles for the phase 'c' at different SVC installation bus 5, and bus 4

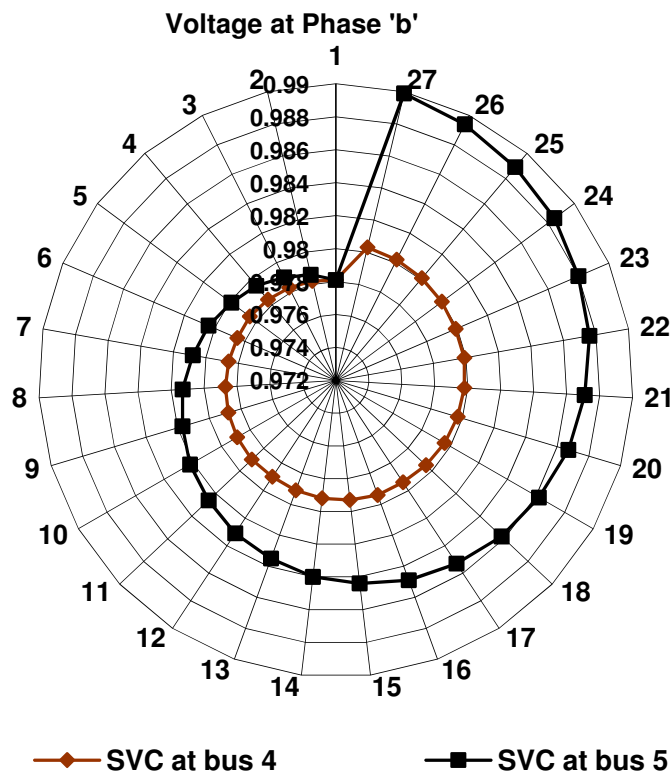

Fig. 17. Voltage profile for the phase 'b' at different SVC installation bus 5, and bus 4

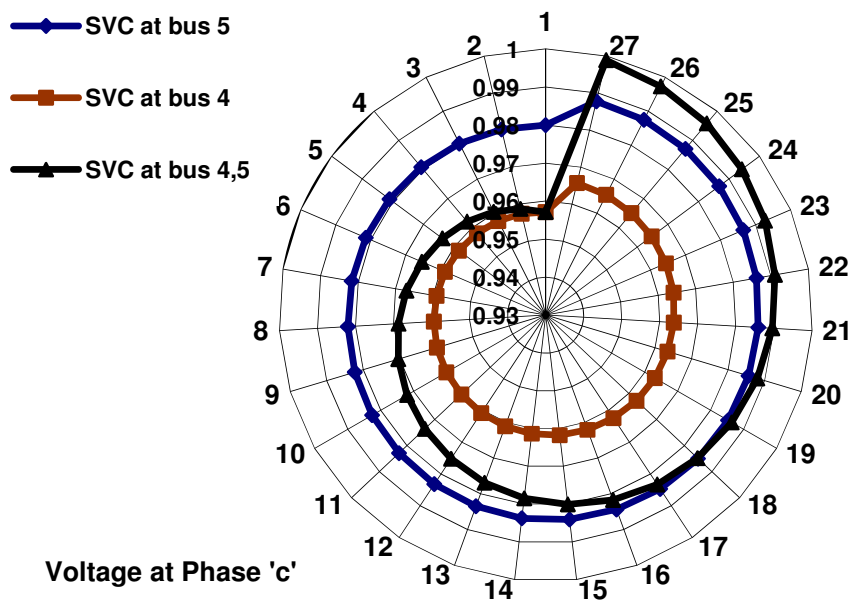

Fig. 18. Voltage profiles for phase 'c': One SVC installed at bus 5, bus 4, and two SVC installed at buses: 4, 5

4.2 Case studies on the IEEE 30-Bus system

4.2.1 Optimal location based negative sequence component

In order to investigate the impact of the efficient location of FACTS devices using complementary information given by negative sequence voltage and to realize a flexible control of reactive power injected by SVC in a network with unbalanced load the following cases were carried out.

Case 1: unbalanced load at Bus 30 with $k_a=1$, $k_b=0.9$, $k_c=1.1$, where k_a , k_b , k_c represent the degree of unbalance.

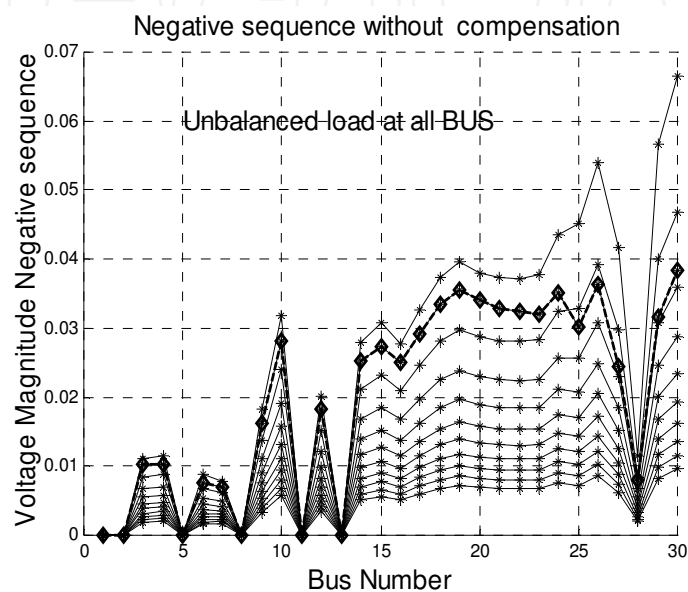

Fig. 19. Negative sequence voltage in all buses with load incrementation- without compensation-unbalance at all Bus

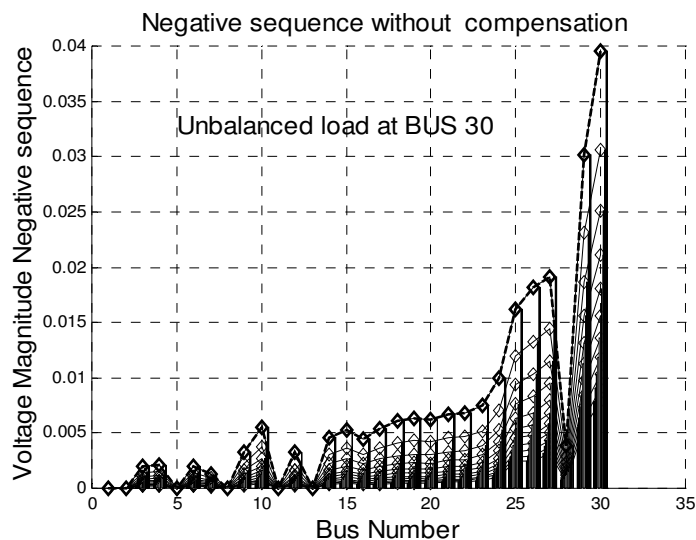

Fig. 20. Negative sequence voltage at all buses without compensation-unbalance-Bus 30

The lowest voltage magnitude is a necessary information and a good index to analyse the voltage stability and to estimate the efficient location of shunt compensator, but not

sufficient, complementary information based in the variation of negative sequence is presented and tested in a network with unbalanced load. Figs. (6-7) give results of the voltage magnitude of an unbalanced three-phase power systems in normal condition with load incrementation, we can seen from Fig. 7 that the lower voltage is at phase 'c'. Figs. (8-9) show the variation of the negative sequence voltage in all buses with load incrementation, without compensation with unbalance at all Bus and unbalance at bus-30. Figs. (10-11) show the variation of the negative sequence voltage in all buses with load incrementation, with balanced and unbalanced compensation and unbalance at bus-30. The amount of negative sequence voltage is reduced greatly in the unbalanced case to 0.0135 p.u compared to the balanced compensation case with 0.0310 p.u.

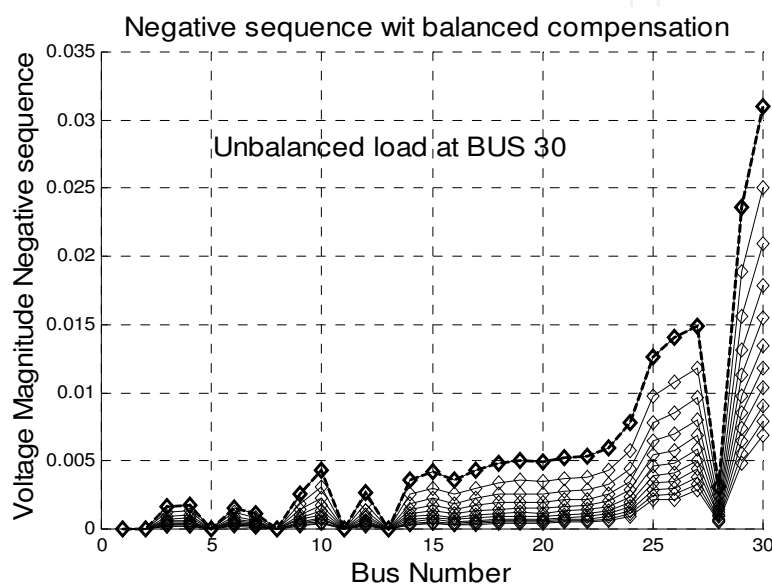

Fig. 21. Negative sequence voltage in all buses with *balanced compensation*. Unbalance at bus 30

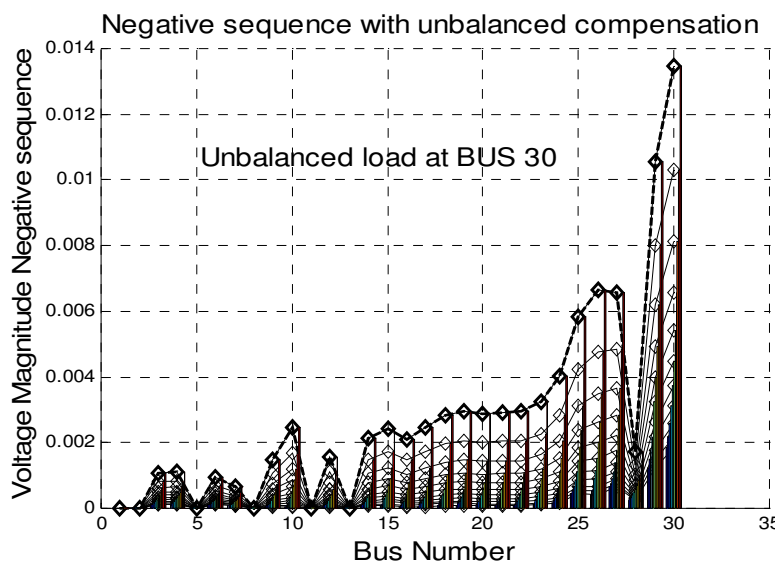

Fig. 22. Negative sequence voltage in all buses with *unbalanced compensation*—unbalance at bus 30

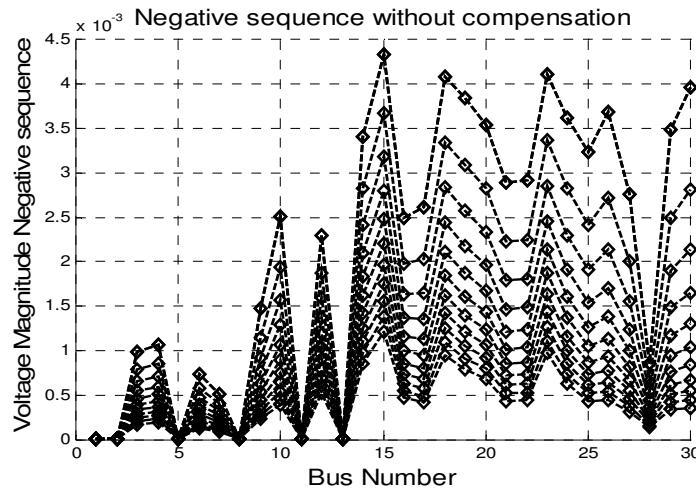

Fig. 23. Negative sequence voltage in all buses with load incrementation – *without compensation* Unbalance at Bus 26

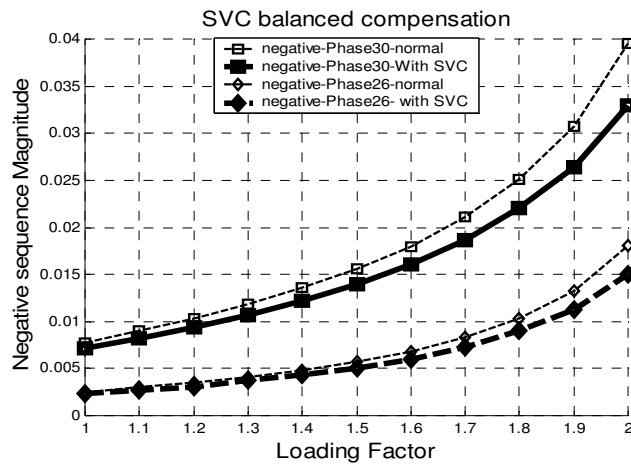

Fig. 24. Impact of SVC Controllers based balanced compensation on negative voltage component: SVC installed at buse 26, and bus 30

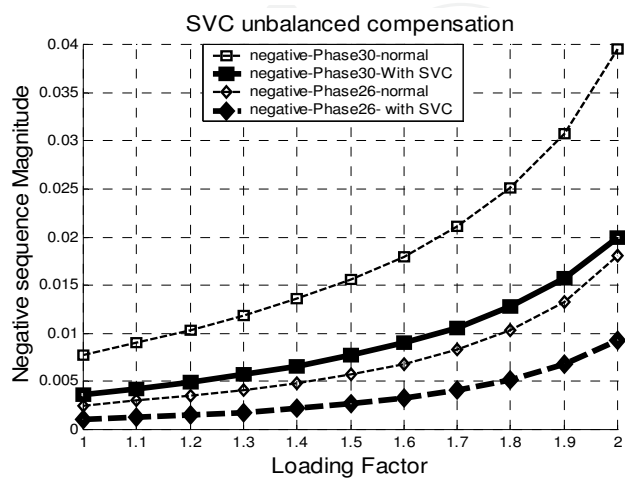

Fig. 25. Impact of SVC Controllers based unbalanced compensation on negative voltage component: SVC installed at bus 26, and bus 30

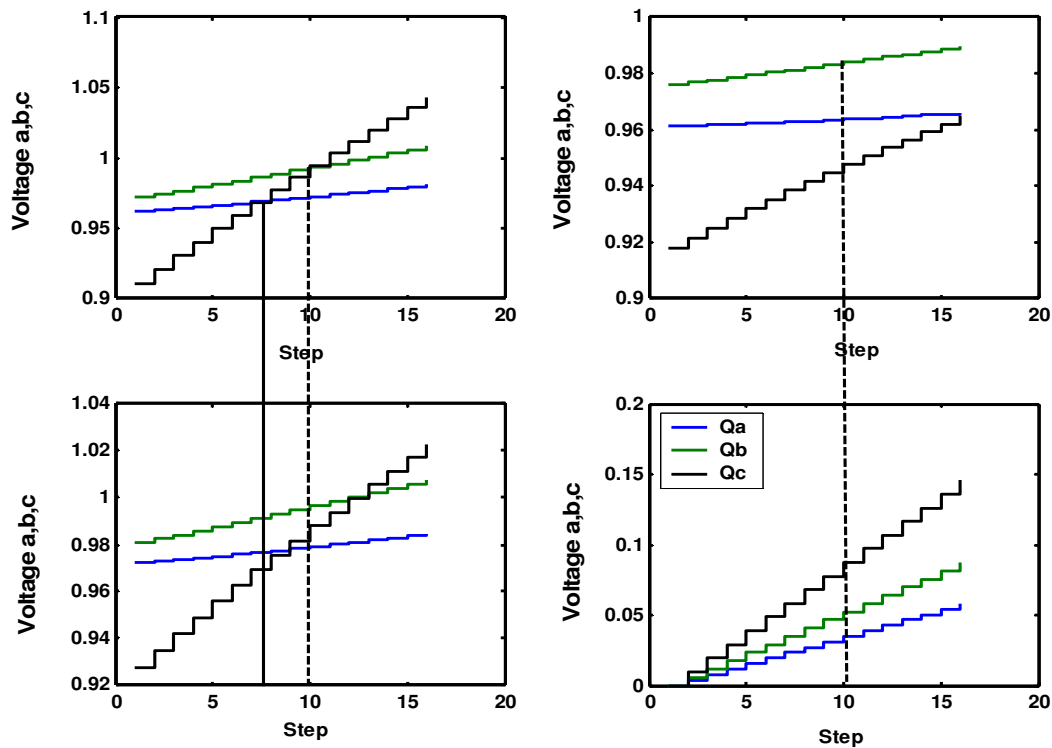

Fig. 26. Minimum reactive power exchanged with SVC installed at bus 30

Bus	Phase A (p.u)	Phase B (p.u)	Phase C (p.u)	
Without Compensation (p.u)				
30	0.9620	0.9721	0.9102	
29	0.9722	0.9808	0.9273	
26	0.9613	0.9759	0.9180	
With one SVC at bus 30				
30	0.9726	0.9935	0.9946	
29	0.9792	0.9967	0.9879	
26	0.9638	0.9841	0.9477	
Q_{svc}^p (p.u)	0.0349	0.0524	0.0873	
RIS^p (p.u)	10.0301	6.6800	4.0096	20.7197

Table 10. SVC at bus 29, step control '10' (ka=1, kb=0.9, kc=1.1, loading factor=1)

In this case an unbalanced load at all buses is applied with $k_a=1, k_b=0.9, k_c=1.1$, where k_a, k_b, k_c represent the degree of unbalance. In Fig. 26, for one SVC installed at bus 30 and at the step control '10', the reactive power for the three phase $[Q_{svc}^p, RIS^p] = [0.0349 \ 0.0524 \ 0.0873 \ 20.7197]$ represent the minimum reactive power needed to assure the degree of system security margin. Fig. 27 shows the impact of the unbalanced compensation to the voltage magnitude in normal condition.

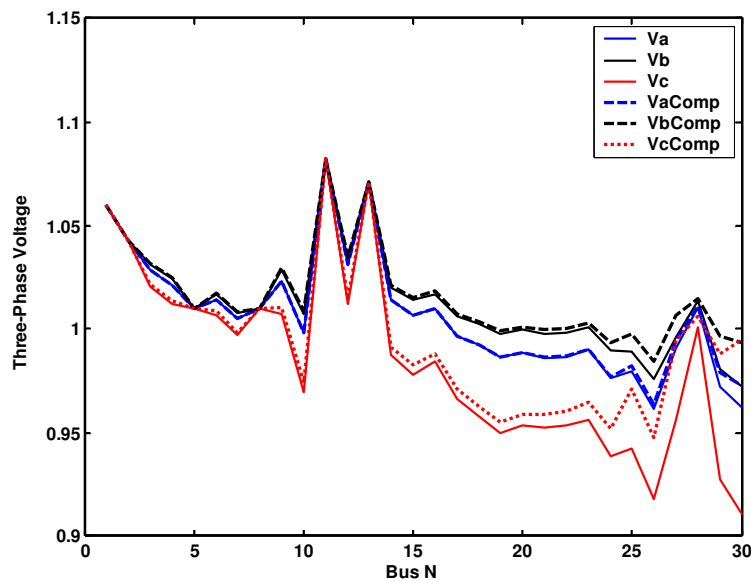

Fig. 27. Three-phase voltage profile improvement with SVC installed at bus 30

5. General results interpretation

1. In our presented approach the real power loss membership function is combined with reactive power loss membership function with the same form to enhance the final decision.
2. The combination of active and reactive fuzzy expert rules with the function coordination that is based on the heuristic strategy leads to better results.
3. In addition it has found that based on the complementary information given by the reactive index sensitivity, the expert engineer can choose economically the size of the shunt compensator to be installed in a practical network. A maximum value of this factor yields the optimal size of SVC and STATCOM rating, this point correspond to the suitable security margin at the minimum Mvar level.
4. Optimal location and sizing of shunt controllers results in lower power loss, better voltage profiles and improvement power quality. Figs 16-17-18 show the voltage profiles of phase 'b', and phase 'c'. It is clear that the location of SVC controllers contribute to the improvement of voltage deviation
5. Our analysis has shown that unbalanced compensation based shunt FACTS devices is an alternative solution to enhance the power quality.
6. In addition to the important points discussed, we can also draw some recommendations for futur research:
 - Further research is needed into this issue (power system operation and control), related to the integration of multi type of FACTS Controllers in unbalanced distribution systems.
 - Optimal location and control of three phase FACTS Controllers with the standard power flow using artificial intelligence techniques is an important research area.
 - The control in real time of FACTS devices requires flexible and robust three-phase models combined with efficient dynamic fuzzy rules to enhance the indices of power quality.

6. Conclusion

Reactive power control based shunt FACTS devices is one of the important issues in power system planning and control. The problem of finding out which locations are the most

effective and how many Flexible AC Transmission System (FACTS) devices have to be installed and controlled in a deregulated and unbalanced practical power systems is a question of great significance for the expert engineers to deliver power to the consumers within the desired power quality required. This chapter has recalled the fundamentals and some specific details related to the improvement of power quality in unbalanced power systems. The proposed technique, demonstrates that an efficient coordination between expertise engineers formulated in practical fuzzy rules with asymmetric dynamic compensation based shunt FACTS devices is able to improve the power system quality in unbalanced power systems. The main objective of the proposed strategy is to find the optimal reactive power compensation between multi shunt FACTS devices (SVC Controllers) in unbalanced power systems based on three-phase power program, the method is applicable to many types of unbalanced network configuration.

Today, the prices of SVCs compensator are not much higher than the traditional system compensation; this will make the applications of shunt FACTS devices especially SVCs economically justified in unbalanced distribution network. Based on results presented in this chapter, we can conclude that integration of FACTS devices models in unbalanced practical distribution power system requires an efficient three-phase power flow program.

7. References

- Acha E., Fuerte-Esquivel C, Ambiz-Perez (2004), FACTS Modelling and Simulation in Power Networks. *John Wiley & Sons*.
- Bansilal, D. Thukaram, K. parthasarathy, An expert system for alleviation of network overloads, *Electric Power System Research*, vol. 40, pp. 143-153, 1997.
- Bhasaputra, P., Bhasaputra and W. Ongsakul, Optimal placement of multi-type FACTS devices by hybrid TS/SA approach, 2003 *IEEE*.
- Birt K. A., Graff J. J., McDonald J.D., and El-Abiad A. H., Three phase load flow program, *IEEE Trans. Power App.Syst*, vol. 95, no. 1, pp. 59-65, Jan/Feb. 1976.
- Chen, B. K., M. S. Chen, R.R. Shoults, C.C. Liang, Hybrid three phase load flow, *Proc-Gener. Transm. Distrib.* vol. 137, No. 3, May 1990.
- El-Keib, A. A., X. Ma, Application of artificial neural networks in voltage stability assesment, *IEEE Trans. Power Systems*, vol. 10, no. 4, pp. 1654-1890, 1995.
- Fuerte CR, Acha E, Tan SG , Rico JJ, Efficient object oriented power systems software for the analysis of large-scale networks containing FACTS controlled branches, *IEEE Trans. Power Systems*, vol. 13, no. 2, pp. 464-472, May 1998.
- Hingorani, N.G, High Power Electronics and Flexible AC Transmission System, *IEEE Power Engineering review*, july 1988.
- Hingorani, NG., Gyugyi L, Understanding FACTS: Concepts and Technology of Flexible A Transmission Systems. *IEEE Computer Society Press*, 1999.
- Mahdad Belkacem, Tarek Bouktir, Kamel Srairi , Dynamic Compensation of the Reactive Energy using a Fuzzy Controller, *Leonardo Electronic Journal of Practices and Technologies*, Issue 7, July-December 2005, pp 1-16, ISSN 1583-1078, Academic
- Mahdad, B., Optimal Power Flow with Consideration of FACTS devices Using Genetic Algorithm: Application to the Algerian Network, Doctorat Thesis, Biskra University Algeria, 2010
- Mahdad, B., T. Bouktir, K. Srairi, A three-phase power plow modelization: a tool for optimal location and control of FACTS devices in unbalanced power systems, *The 32nd Annual*

- Conference of the IEEE Industrial Electronics Society, Conservatoire National des Arts & Metiers Paris, FRANCE*, November 7-10, 2006 Page(s): 2238 - 2243, 1-4244-0136-4/06.
- Mahdad, B., T. Bouktir, K. Srairi, Flexible methodology based in fuzzy logic rules for reactive power planning of multiple shunt FACTS devices to enhance system loadability, *Power Engineering Society General Meeting*,. IEEE, 24-28 June 2007 Page(s):1 - 6, Digital Object Identifier 10.1109/PES.2007.385750.
- Mahdad, B., T. Bouktir, K. Srairi, Methodology Based in Practical Fuzzy Rules Coordinated with Asymmetric Dynamic Compensation Applied to the Unbalanced Distribution Network, *International Review of Electrical Engineering (IREE)*, vol. 3, no. 2, pp. 145-153 (2007), ISSN 1827- 6660, Praise Worthy Prize, Italy.
- Mahdad, Belkacem; Bouktir, T.; Srairi, K. A Three-Phase Power Flow Modelization: A Tool for Optimal Location and Control of FACTS Devices in Unbalanced Power Systems, *IEEE Industrial Electronics, IECON -32nd Annual Conference on*, 6-10 Nov. 2006 Page(s):2238–2243.
- Mamdouh Abdel-Akher, Khalid Mohamed Nor, and Abdul Halim Abdul Rachid, Improved three-phase power-flow methods using sequence components, *IEEE Trans. Power Systems*, vol. 20, no. 3, pp. 1389-1397, August 2005.
- Marques B., and N. Toranto, A knowledge based system for supervision and control of regional voltage profile and security, *IEEE Trans. Power Systems*, vol. 20, no. 4, pp. 400-407, 2005.
- Mayordomo, J.G, M. Izzeddine, S. Martinez, R. Asensi, A. Gomez Exposito and W. Xu, Compact and flexible three-phase power flow based on a full Newton formulation, *IEE Proc-Gener. Trans. Distrib.* Vol. 149, No. 2, March 2002.
- San-Yi Lee, Wei-Nan Chang, and Chi-Jui Wu, A compact algorithm for three-phase three-wire system reactive power compensation and load balancing, *IEEE Catalogue No. 95TH 8130*, pp. 358-363, IEEE 1995.
- Scala, M. L., M. Trovato, F. Torelli, A neural network based method for voltage security monitoring, *IEEE Trans. Power Systems*, vol. 11, no. 3, pp. 1332-1341, 1996.
- Su, C. T., C. T. Lu, A new fuzzy control approach to voltage profile enhancement for power systems, *IEEE Trans. Power Systems*, vol. 11, no. 3, pp. 1654-1659, 1996.
- Tmsovic, K. , A fuzzy linear programming approach to the reactive power/voltage control problem, *IEEE Trans. Power Systems*, vol. 7, no. 1, pp. 287-293, 1992.
- Trujillo, T.V, C.R. Fuerte-Esquivel and J.H. Tovar Hernandez, Advanced three-phase static VAR compensator models for power flow analysis, *IEE Proc-Gener. Transm. Distrib.* Vol. 150, No. 1, January 2003.
- Udupa, A. N., D. Thukaram, and K. Parthasarathy, An expert fuzzy control approach to voltage stability enhancement, *International Journal of Electrical Power and Energy Systems*, vol. 21, pp. 279-287, 1999.
- William D. Rosehart, Claudio A. Canizares, and Victor H. Quintana. Effect of detailed power system models in traditional and voltage-stability-constrained optimal power-flow problems, *IEEE Trans. Power Systems*, vol. 18, no. 1, February 2003.
- Wilsun Xu, Hermann W. Dommel, Jose R. Marti, A generalised three-phase power flow method for initialisation of EMTP simulations, pp. 875-879, *IEEE* 1998.
- Xiao-Ping Zhang, Ping Ju and Edmund Handshin, Continuation three-phase power flow: A tools for voltage stability analysis of unbalanced three-phase power systems, *IEEE Trans. Power Systems*, vol. 20, no. 3, pp. 1320-1329, August 2005.
- Zhang, X. P., H. Chen, Asymmetrical three-phase load-flow study based on symmetrical component theory, *IEE Proc-Gener. Transm. Distrib.* Vol. 141, No. 3, May 1994.

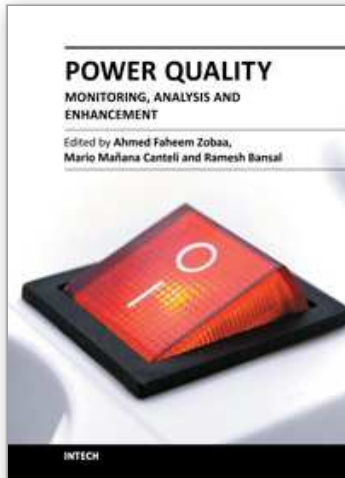

Power Quality – Monitoring, Analysis and Enhancement

Edited by Dr. Ahmed Zobaa

ISBN 978-953-307-330-9

Hard cover, 364 pages

Publisher InTech

Published online 22, September, 2011

Published in print edition September, 2011

This book on power quality written by experts from industries and academics from various countries will be of great benefit to professionals, engineers and researchers. This book covers various aspects of power quality monitoring, analysis and power quality enhancement in transmission and distribution systems. Some of the key features of books are as follows: Wavelet and PCA to Power Quality Disturbance Classification applying a RBF Network; Power Quality Monitoring in a System with Distributed and Renewable Energy Sources; Signal Processing Application of Power Quality Monitoring; Pre-processing Tools and Intelligent Techniques for Power Quality Analysis; Single-Point Methods for Location of Distortion, Unbalance, Voltage Fluctuation and Dips Sources in a Power System; S-transform Based Novel Indices for Power Quality Disturbances; Load Balancing in a Three-Phase Network by Reactive Power Compensation; Compensation of Reactive Power and Sag Voltage using Superconducting Magnetic Energy Storage; Optimal Location and Control of Flexible Three Phase Shunt FACTS to Enhance Power Quality in Unbalanced Electrical Network; Performance of Modification of a Three Phase Dynamic Voltage Restorer (DVR) for Voltage Quality Improvement in Distribution System; Voltage Sag Mitigation by Network Reconfiguration; Intelligent Techniques for Power Quality Enhancement in Distribution Systems.

How to reference

In order to correctly reference this scholarly work, feel free to copy and paste the following:

Belkacem Mahdad (2011). Optimal Location and Control of Flexible Three Phase Shunt FACTS to Enhance Power Quality in Unbalanced Electrical Network, Power Quality – Monitoring, Analysis and Enhancement, Dr. Ahmed Zobaa (Ed.), ISBN: 978-953-307-330-9, InTech, Available from:
<http://www.intechopen.com/books/power-quality-monitoring-analysis-and-enhancement/optimal-location-and-control-of-flexible-three-phase-shunt-facts-to-enhance-power-quality-in-unbalan>

INTECH
open science | open minds

InTech Europe

University Campus STeP Ri
Slavka Krautzeka 83/A
51000 Rijeka, Croatia
Phone: +385 (51) 770 447
Fax: +385 (51) 686 166

InTech China

Unit 405, Office Block, Hotel Equatorial Shanghai
No.65, Yan An Road (West), Shanghai, 200040, China
中国上海市延安西路65号上海国际贵都大饭店办公楼405单元
Phone: +86-21-62489820
Fax: +86-21-62489821

www.intechopen.com

www.intechopen.com

IntechOpen

IntechOpen

© 2011 The Author(s). Licensee IntechOpen. This chapter is distributed under the terms of the [Creative Commons Attribution-NonCommercial-ShareAlike-3.0 License](#), which permits use, distribution and reproduction for non-commercial purposes, provided the original is properly cited and derivative works building on this content are distributed under the same license.

IntechOpen

IntechOpen