

We are IntechOpen, the world's leading publisher of Open Access books Built by scientists, for scientists

4,800

Open access books available

122,000

International authors and editors

135M

Downloads

Our authors are among the

154

Countries delivered to

TOP 1%

most cited scientists

12.2%

Contributors from top 500 universities



WEB OF SCIENCE™

Selection of our books indexed in the Book Citation Index
in Web of Science™ Core Collection (BKCI)

Interested in publishing with us?
Contact book.department@intechopen.com

Numbers displayed above are based on latest data collected.

For more information visit www.intechopen.com



Photodiagnosis and Photodynamic Therapy of Cutaneous Melanoma

Ekaterina Borisova¹, Vanya Mantareva², Irina Bliznakova¹,
Ivan Angelov², Latchezar Avramov¹ and Elmira Pavlova³

¹*Institute of Electronics, Bulgarian Academy of Sciences*

²*Institute of Organic Chemistry with Center on Phytochemistry,
Bulgarian Academy of Sciences*

³*Medical Center of University Hospital "Tsaritzha Yoanna-ISUL"
Bulgaria*

1. Introduction

Skin cancer is one of the most widespread tumours. However, despite the progress achieved in all clinical diagnostic techniques, the most severe of those tumours - cutaneous melanoma, continues to be an important problem of social health. A large number of optical techniques have been recently applied in the clinical practice in view of obtaining qualitatively and quantitatively new data from cutaneous neoplasia. Due to their high sensitivity in detecting small changes, spectroscopic techniques are now widely used for detection of early changes in biological tissues. Fluorescence detection of normal and abnormal tissues is among the most promising such approaches as it makes use of naturally existing fluorescent molecules (in the case of autofluorescence) or added fluorescent markers (in the case of exogenous fluorescence) of high importance. Fluorescent markers are introduced wherever native fluorescence is not informative enough to be used for diagnostic goals due to the absence or non-specificity of the changes in the tumour vs. the normal tissues.

The fluorescent diagnostic techniques are particularly suitable in diagnosing melanin-pigmented cutaneous pathologies. Melanin is a pigment which absorbs strongly within practically entire visible spectral range. Its high content in these lesions leads to low penetration depth of the excitation light and a small amount of re-emitted fluorescent light that can be collected and used for fluorescent analysis of the pathology under investigation. Therefore, fluorescent diagnosis of melanin-pigmented neoplasia, such as cutaneous malignant melanoma and its differentiation vs. dysplastic precursors and similar benign skin pathologies, such as nevi, is an elaborate and challenging task for all researchers working in the field of biomedical photonics. Photodiagnosis (PD) and photodynamic therapy (PDT) have been established as emerging modalities for a variety of pathogenic conditions including pigmented melanoma (Awan et al., 2006; Davids and Kleemann, 2010). The number of cases of pigmented malignancies has been steadily increasing during the last decades in general, and, in particular, malignant melanoma (MM) incidence has also increased. Melanomas are the most aggressively developing form of dermatological cancers due to the difficulty of diagnosis at an early stage combined with the low rate of success of

the treatment at the late stage. The key factor of success with melanoma disease is an early detection followed by effective treatment procedures. PD and PDT could be the proper answer in achieving this goal.

1.1 Autofluorescence of cutaneous melanoma

Autofluorescence has been proven to be a very sensitive and accurate method for detection of early changes in many cancer types; however, due to the specific optical properties of melanin, fluorescence spectroscopy application to malignant melanoma detection is still a matter of debate. A few attempts have been made to detect fluorescence of melanin itself based on natural and synthetic melanin solutions. The authors reported that a major part of the excitation energy (>99,9%) in melanin molecules dissipates through non-radiative pathways (Lohmann and Paul, 1988; Meredith and Riesz, 2004). The natural fluorescence of melanin related to its oligomeric units is of extremely low intensity, with emission spectrum in the range 450 – 550 nm (Nighswander-Rempel et al., 2005; Perna et al., 2009). The first reports on using fluorescence spectroscopy for diagnostics of melanin-pigmented neoplasia were published in the late 80's and early 90's (Leffel et al., 1988; Lohmann et al., 1991).

There is still no universal procedure for photodiagnosis and differentiation between malignant melanoma and other melanin-pigmented pathologies. Melanin is known to have unique light absorption behaviour, completely different from that of the other organic fluorophores, namely, an exponential decrease of the absorption from the UV to the near infrared region (Nighswander-Rempel et al., 2005). A great number of studies have been carried out in this field obtaining promising results based on autofluorescence and on exogenous fluorescence detection of these cutaneous malignancies. Interesting approaches for diagnosis have been employed based on the autofluorescence properties of melanoma and its subtypes using additional analysis of the spectra detected, or specific algorithms, some of which allow relatively high sensitivity and specificity of tumour detection and evaluation (Chiwot et al. 2001; Borisova, 2006). The authors reported values for sensitivity of 82.5% and specificity of 78.6% after ultraviolet irradiation of the tumours (Chwirot et al., 1998).

In our investigations with excitation light with wavelength 337 nm used in autofluorescence measurements, the sensitivity obtained was about 77,8% and the specificity of 93,3% (Borisova et al., 2008b). Whether melanoma autofluorescence is an appropriate diagnostic tool is still debatable. Our investigations did not reveal any significant spectral shape changes (Borisova, 2006), only a significant fluorescent signal intensity decrease in the case of melanoma. While Lohmann and co-authors (Lohmann et al. 1991) concluded that autofluorescence spectroscopy is capable of differentiating melanoma from normal tissue using ultraviolet excitation (365 nm), Sterenborg and co-authors (Sterenborg et al., 1995) reported that they did not observe a significant correlation between the fluorescence emission and the histopathological examination of the lesions studied. Thus, melanoma remains a work in progress for non-invasive diagnosis.

Low-level fluorescent signals distorted by the melanin absorption can be detected in spite of the pigment influence on the spectra registered by the means of high-sensitivity detectors, which appeared recently in the market (Borisova et al., 2005). The signals detected from melanoma lesions originate mainly from co-enzymes and structural proteins (Borisova et al., 2008a).

A promising approach based on femtosecond two-photon excitation of melanin was also proposed (Teuchner et al. 1999). Despite its potential, this method is very expensive and inconvenient to be introduced into the standard clinical practice.

1.2 Exogenous fluorescence (photodiagnosis) of cutaneous melanoma

Another possible way of detection is based on introducing exogenous fluorescent markers in the lesions, as melanoma lesions exhibit very low autofluorescence signals. The conventional application of a fluorescent contrast agent as a positional marker for detection of malignancies appears to be commonly used for diagnosis of pigmented melanoma tumours.

The exogenous fluorophores called photosensitizers (PS) have found the widest application; they are used to improve the fluorescent detection of melanin-pigmented neoplasia. These compounds could be used for photodiagnosis, as well for initiation of a photodynamic effect in the tumour cell, so that one could combine photodiagnosis with a subsequent photodynamic therapy of the lesion.

Bearing in mind the specific optical properties of melanin, especially its strong absorption in the shorter wavelengths' spectral range, scientists have focused their efforts on the synthesis and study of long-wavelengths photosensitizers, such as phthalocyanines and naphthalocyanines, which absorb in the 670-760 nm range and fluoresce in the 680 - 800 nm range (Woehrle et al., 1999; Peeva et al., 1999; Shopova et al., 1999; Mantareva et al., 2005).

The incident light must be of appropriate wavelength to ensure deep penetration in order to excite the native tissue chromophores of the malignant tissue. The diagnostic light usually covers the part of visible spectra (488-635 nm) where the so called endogenous sensitizers absorb strongly. The fact that the absorption spectra for normal vs. pathogenic tissues are different is a useful tool allowing fast diagnosis (Borisova et al., 2005). The application of exogenous chromophores can enhance the images and can further assist the therapy. It is important that the applied light's wavelength to be shifted away from the absorption peak of the tumour localizing photosensitizers, so that detection at both wavelengths should be possible. Recently, PSs that possess the properties of good tumour tissues uptake and retention for fluorescent detection and relatively high photochemical parameters of singlet oxygen generation and other ROSs were defined as theranostic drugs (Rai et al., 2005). The appropriate use of the competitive approaches after light excitation is limited by the absorption coefficients of the native chromophores of tumour cells and by the light scattering properties of the constituents of the tumour tissue. External to the tissue natural or synthetic photosensitizers that would allow large intensity fluorescence demarcation and powerful photosensitizing processes are still under development.

1.3 Photodynamic therapy of cutaneous melanoma

Besides the initial diagnosis of the pathology, an important clinical aspect is related to the following treatment and therapeutic modalities, which could be applied on sensitive and severe skin lesion, such as malignant melanoma. The photodynamic therapy modality is a curvative tool developed and applied in the clinical practice in the last few decades, whereby photosensitizers absorbing in the near-infrared spectral region and selectively accumulated in tumour tissue transfer their energy after light irradiation to the surrounding oxygen and produce singlet oxygen, which then reacts with and destroys adjacent proteins and lipids in the cell membrane structures, or switches on the processes of apoptosis in the tumour cells. These compounds can also fluoresce; this combination of a possibility for photodetection and the following photodynamic effect of the drugs developed for photodynamic therapy applications is very promising and useful for the clinical practice.

The photodynamic approach appears as a complementary methodology which is not developed for pigmented melanomas (Mac Donald et al., 2001). The PDT is based on a photoactive compound (photosensitizer, PS) and a proper light excitation, together with the

presence of molecular oxygen (Dougherty, 1992). As soon as selective localization of PS into the tumour tissue occurs, visible light must be applied locally to provoke the photophysical mechanisms of excitation of the singlet and triplet states of PS, the latter being metastable and can be involved in chemical reactions. The transfer of the light energy absorbed by the tissue or only by the PS can take place through radiative decay of the singlet state (fluorescence), which is used in non-invasive diagnosis. The same PS can undergo non-radiative relaxation to the lower energy triplet excited state of PS, which can participate in chemical reactions with the surrounding molecules. Basically, two mechanisms of photosensitization have been established (Foote, 1991). The more important one takes place via an energy transfer from the triplet PS to the ground state of molecular oxygen from atmospheric air, which results in the formation of highly cytotoxic singlet oxygen. The process is known as mechanism type II of photooxidation. Concurrently, the mechanism takes place of an electron or proton transfer from the excited triplet PS to the surrounding tissue molecules. As a result, reactive oxygen species (ROS) are generated. This is known as mechanism type I of photosensitization.

Diverse results have been reported on the application of exogenous photosensitizers.

PDT appears to be a promising new approach for an early detection and sufficient therapy of the most aggressive forms of cancer, such as pigmented melanoma tumours. The clinically approved photosensitizers are the porphyrin derivatives (Photofrin® and Haematoporphyrin derivative) and aminolevulinic acid (ALA) which is a precursor of the porphyrin-like compound protoporphyrin IX. However, the so-called first generation sensitizers exhibit the disadvantage of optical limitation which precludes the application of the existing drugs to the diagnosis and treatment of pigmented melanomas. The difference in the ALA-induced protoporphyrin IX autofluorescence (excitation at 365 and 405 nm, emission at 635 nm) from malignant melanoma as compared with healthy skin in humans appears to be related to the different oxygenation rather than to the specificity of the fluorophores of malignancies. The fluorescence-based detection of abnormal tissues during the therapy is based on temporary differences in the kinetics of drug uptake between normal and malignant cells. At present, 5-aminolevulinic acid (ALA, with commercial name Levulan®) is used for the formation of protoporphyrin IX. The product of the haem biosynthesis is being considered as a drug for fluorescent diagnosis. The further development and evaluation of advanced fluorescent contrast agents is an important research topic which could lead to a successful solution of many fundamental scientific problems. Unlike other primary cutaneous malignancies, melanoma has a strong tendency for proliferation; some authors (Allison et al., 2006) even consider that local treatment by photodynamic therapy or any other local treatment modality prior to sentinel node procedure for evaluation of lymphatic metastasis is contraindicated. As the survival is based generally on the successful immunomodulation on a system level, local photodynamic therapy would only be a part of the treatment procedures. The photodynamic therapeutic immunomodulatory effect achieved seems to be very important in the evaluation of the PDT effect in the local control of the lesion and on the survival rate in general (Saczko et al., 2005; Allison et al., 2006; Kaplan et al., 2008). This effect is still under investigations and a large amount of work remains to be done.

The further development of PDT agents leading to the development of a second generation of far-red absorbing photosensitive dyes with improved spectral properties was the aim of our research in recent years (Borisova et al., 2005; Wohrle et al., 1999, Mantareva et al., 2005). The new photodynamic drugs were designed to become more efficient contrast agents for

fluorescence diagnosis of early-stage malignancies, and especially of pigmented melanomas. Other researchers have also reported very promising results from PDT treatment of pigmented melanoma with a new generation of photosensitizers making melanoma cells highly sensitivity to the PDT (Davids and Kleemann, 2010; Kolarova et al., 2007a; Kolarova et al., 2007b). PDT treatment with a new generation of photosensitizers was also proposed to be used as an additional palliative procedure for patients with malignant melanoma (Kubler, 2005). A part of our own research interests were the highly conjugated macrocyclic complexes from the group of tetra-isoindoles, such as phthalocyanines and naphthalocyanines. Phthalocyanines are characterized by a red-shifted and strong absorption maximum (> 670 nm) as compared to porphyrins (~ 630 nm). The zinc(II) coordinated complexes were studied as efficient fluorescent contrast agents of an experimental B16 pigmented melanoma on mice. Several cationic Zn(II)-phthalocyanines (ZnPcRs) with different hydrophilic/lipophilic balance were synthesized and studied as promising diagnostic agents for pigmented melanoma. It was shown that the long wavelength absorption together with a high fluorescence intensity at the wavelength over 680 nm as well as the selective tumour cells uptake as compared to the surrounding normal tissue result in two advantages over the porphyrins and derivatives. The additional benzene rings lead to extended Pc analogues such as naphthalocyanines. They have the advantage of a stronger and deeper far-red absorption (760-790 nm) than phthalocyanines. A number of *in vivo* studies on B16 pigmented melanoma treated with Si(IV)- and Zn(II)-naphthalocyanines at different therapeutic protocols showed the potential value of the PDT approach when combined with some other methodology.

The clinical acceptance of the method was achieved in 1998 for treatment of non-pigmented tumour localizations with porphyrin derivatives (Haematoporphyrin derivative, Photofrin) and aminolevulinic acid (ALA) by application of visible light at 635 nm (Brown et al., 2004). The porphyrin derivatives and ALA, which is a precursor in the biosynthesis of protoporphyrin IX, have shown low efficiency for pigmented melanomas (Ibbotson, 2010). This was explained by the overlapping of the absorption spectra of the melanin pigment and porphyrins. The low transparency of the pigmented tissue at the excitation wavelength typical for porphyrins (around 630 nm) minimized the photosensitizing process efficiency. The pigmented melanomas are known as being weakly affected by the so called first generation photodynamic sensitizers, which are porphyrin based molecules (Kalka et al., 2000). An ideal PS for tumours needs to absorb at longer wavelengths to be suitable for treating melanomas with pigments. The so-called second-generation PSs were developed to have improved physical, chemical and spectral properties. The representative groups of PSs are the pheophorbide derivative, chlorine-type molecules like benzoporphyrin monoacid derivative (Verteporfin), and more extended macrocycles such as phthalo- and naphthalocyanines (sulfonated MPcs, Photosense). These PSs have energy absorption band in the far red spectral region (> 660 nm) with high absorption coefficients which allows a deeper tissue penetration of the excitation light, enabling it to penetrate blood, melanin and fibrotic tissue.

The studies in our laboratory on highly pigmented variety of malignant melanoma B16 demonstrated an effective diagnosis and PDT response by using phthalocyanine and naphthalocyanines metal complexes (MPcs and MNcs) with intensive far red absorption band (Michailov et al., 1997; Peeva et al., 1999; Mantareva et al., 1997; Woehrle et al., 1999). The competition for the absorption of melanin with the applied light decreases as a single-exponent when the wavelength is increased (Mantareva et al., 2005). These photosensitive

compounds are characterized by a large molar extinction coefficient ($1-5 \times 10^5 \text{ M}^{-1} \text{ cm}^{-1}$) in the spectral range around 675 nm (MPcs) and 770 nm (MNcs) where the pigmented melanomas have minimal absorption (Sounik et al., 1990).

1.4 PD and PDT of melanoma – applications

In view of improving the early diagnosis and the differentiation of risk lesions, we proposed a method of evaluating the autofluorescent characteristics of several common cutaneous benign and malignant lesions. Pigmented melanoma may simulate benign lesions, including seborrheic keratoses, hemangioma, compound and dysplastic nevi. Amelanotic malignant melanoma may clinically mimic a basal cell carcinoma. All these pathologies were investigated and their fluorescent spectra and specific features were evaluated vs. malignant melanoma pathologies for development of a broad clinically valuable algorithm for melanoma detection based on the autofluorescent properties of skin lesions. The origins of diagnostically significant spectral features were discussed. The differentiation algorithm of benign/dysplastic/malignant pigmented skin melanin-pigmented lesions proposed allowed us to differentiate MM with sensitivity about 78% and specificity more than 90 %. These numbers give a diagnostic accuracy of about 70% using the autofluorescence signals received.

To improve the diagnostic accuracy, exogenous photosensitizers need to be applied. A large number of experiments have been already carried out using photosensitizers from the phthalocyanines group (Mantareva et al., 2005). These compounds have very promising optical properties in terms of fluorescence quantum yield and photodynamic properties and high selectivity to the tumour cells. Cationic phthalocyanines differing in their lipophilicity were studied as long-wavelength absorbing fluorescent markers for pigmented melanoma tumour on a model animal (mice) (Fig. 1). In order to study the transport through the cellular membranes, lipophilic and hydrophilic Pcs were prepared. Their fluorescence behaviour was studied in solutions (dimethylsulfoxide) (Fig. 2) and in turbid media (incorporated into the cells). In vivo fluorescence detection studies showed a higher in situ discrimination of the tumour from the healthy surrounding tissue compared with the commonly used drugs. The limitations of pigmented melanomas detection when using ALA can be avoided by using cationic phthalocyanine complexes with a proper hydrophilic/lipophilic balance. The proposed experimental fluorescence spectroscopy technique (Fig. 3) is suitable for clinical application in fluorescence detection of pigmented malignancies. In vivo fluorescent diagnostic potential of the studied compounds concerning pigmented melanoma was demonstrated, so that clinical studies on humans are foreseen in our long-term plans with the purpose of introducing photodiagnostics and photodynamic therapy of malignant melanoma.

Both autofluorescence and exogenous fluorescent detection have their place in the clinical practice. The former method could be used as a screening tool for initial detection and evaluation of cutaneous pathologies, while the latter must be applied on suspicious cases, where it could be used as an affirmative test of the initial diagnosis, as well as a tool for photodynamic therapy of the neoplasia, if such is diagnosed as cutaneous pigmented melanoma.

2. Chemistry of phthalocyanines as photosensitizers for pigmented melanoma

During the last decades of intensive research on PDT with phthalocyanines, several of them were proposed as potential candidates for second generation photosensitizers. In concerns

of their chemistry, the strong lipophilic and aggregation properties of the macrocycle facilitate the proper tailoring of the Pcs structure.

Most of the well-known Pcs under physiological conditions are insoluble, unstable to light and tend to form dimers and higher aggregates which leads to a dramatic decrease of photochemical properties of the generation of ROSs and, in turn, the PDT effectiveness. Overcoming these limitations is the crucial factor for potential clinical applications. A number of suitable substitutions on the peripheral position of the ring, as well as axially to the coordinated metal ion have been devised and tested by *in vitro*/ *in vivo* experiments.

Several Zn(II) naphthalocyanines with differing substituents (amino-, amide-, sulfuric acid - groups) and Si(IV) with methoxyethylglycol axial substitution were studied in our group (Mantareva and co-authors, 1997, 1999, 2005). The results showed that after incorporation of liposome vesicles ZnNcA, which has four benzamido-substituents, had a high photodynamic response for B16 pigmented melanomas.

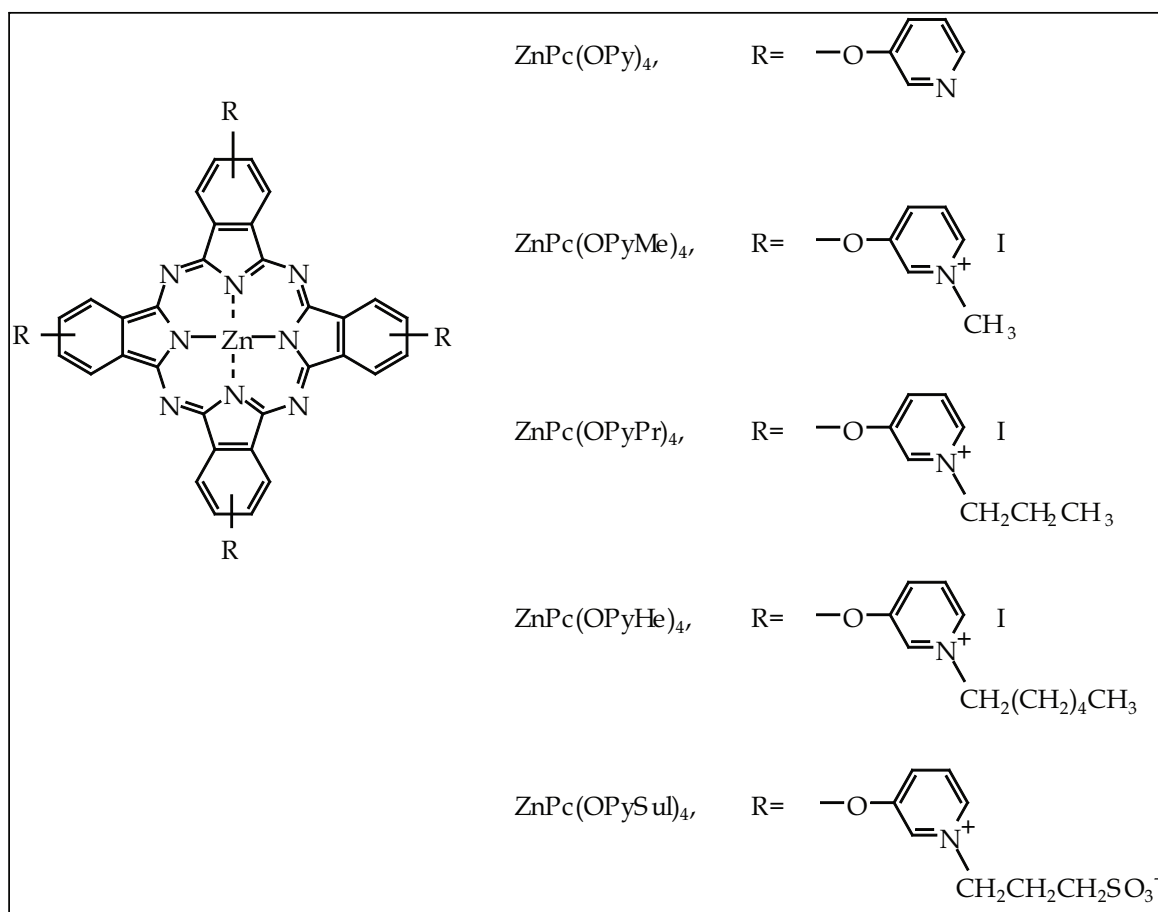

Fig. 1. Chemical structure of Zn(II)-phthalocyanine with pyridyloxy substituents with increasing hydrocarbon chain to N-atom

The coordinated with silicon (IV) naphthalocyanine axially substituted with polyethyleneglycol (SiNc) was synthesized and studied as promising for PDT of B16 pigmented melanoma (Mantareva et al., 1997; Woehrle et al., 1999). Other authors have studied Si(IV) naphthalocyanine (isoBO-SiNc) for PDT of B16 pigmented melanoma with pretreatment by high-peak-power (HPP) laser 1064 nm irradiation, which enhanced the tumour susceptibility to conventional PDT (Sounik et al., 1990; Buseti et al., 1998).

3. Absorbance of melanin and other tissues' chromophores vs. phthalocyanines

The strong absorption in the red and far-red region of the visible spectrum ensures deeper light penetration that does not depend on the melanin pigment. The typical absorption spectrum of Pcs is characterized by a strong Q-band around 675 nm and with a half as intensive Soret band, which lies around 350 and 360 nm (Fig. 1). By adding substituents, the position of the maxima can vary by 5-8 nm, to the red with increase of the molar absorption coefficients. We studied the absorption spectra of endogenous chromophores which are good absorbers of visible light (Mantareva et al., 2005). Figure 2 presents the spectra of natural chromophores such as riboflavin, hemoglobin, cytochrome C and melanin extracted from B16 pigmented melanoma.

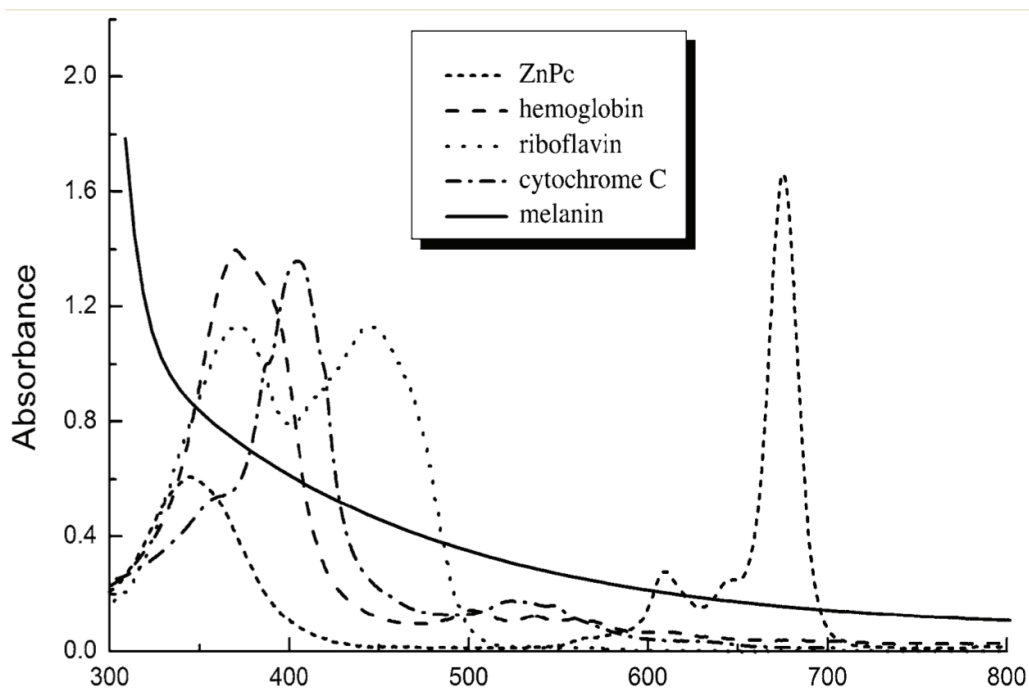

Fig. 2. Absorption spectra of Zn(II)-phthalocyanine (DMSO) and native tissues chromophores (hemoglobin, riboflavin, cytochrome C, all in saline) vs. melanin (1N NaOH) (Mantareva et al., 2005)

Melanin showed a mono-exponential decrease of the absorption from the UV to the near IR region (300-800nm). The absorbance of unsubstituted ZnPc is typical for phthalocyanines. There is only a limited overlapping of the spectra of native chromophores and ZnPc as a photosensitizer. When the excitation light is not in the region of the absorbance of the tissue, light is not interacting with the tissue pigments, all light energy can be absorbed by the photosensitizer localized in a pigmented melanoma tumour. Two optical processes that influence these effects must be taken into account, namely, malignant tissue's absorption and light scattering. Both are known to decrease while the wavelength is increased (635-850nm). In the case of a deeply pigmented tumour tissue, such as B16 pigmented melanoma, the absorption by melanin even in the far-red region (>700nm) is not negligible. The melanin absorption reduces the depth of light penetration and further limits the effect of photodiagnosis and therapy. The depth of light penetration and the light scattering are recognized as crucial for controlling the response of tumours to PDT. In our previous

work with naphthalocyanines, we showed the strong absorbance (776 nm , $5 \times 10^5 \text{ M}^{-1} \text{ cm}^{-1}$) of these compounds and a successful treatment of B16 pigmented melanoma implanted in mice (Mantareva et. al., 1997; Peeva et. al., 2001). However, the PDT effect was still incomplete, probably as a result of the low drug selectivity and the insufficient light penetration to the deeper pigmented melanoma layers.

4. Photobiology of B16 pigmented melanoma

4.1 Uptake study

The uptake study of the group of phthalocyanines with increased hydrophobicity depending on the attached hydrocarbon chain to the methypyridyloxy group (ZnPcMe, ZnPcPr, ZnPcHe and ZnPcDo) was carried out by the experimental set-up, which is presented on Fig. 3.

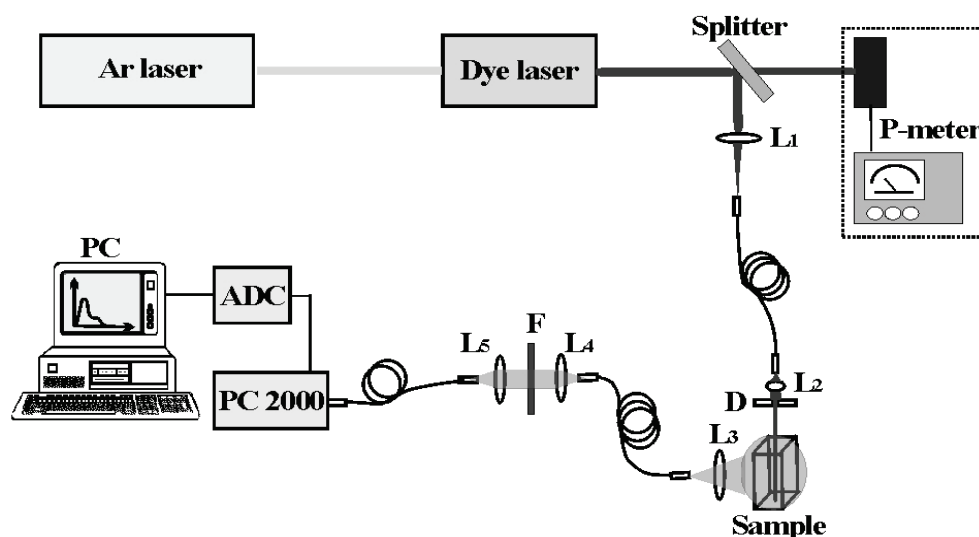

Fig. 3. The experimental set-up for fluorescence determination of photosensitizer uptake (Mantareva et. al., 2005)

The samples of B16 melanoma cells were incubated with respect to ZnPcs ($1.6 \mu\text{M}$ and $2.3 \mu\text{M}$) and the fluorescence was measured after tissue chemical extraction. The data showed the amount of dye per mg tumour mass (Fig 4). The time-dependence curves were obtained within a 6-hour follow-up period. The results showed that the maximal amounts of ZnPcs in the pigmented melanomas tissue (between $2.3\text{-}7.1 \text{ nmol mg}^{-1}$) as compared to the surrounding skin/ epithelial cells were reached 90 min after injection.

Considering the hydrophilic vs. hydrophobic nature of the studied ZnPcs, which were evaluated by their partition coefficients, the uptake results showed a highest uptake in the case of an amphiphilic compound (ZnPcHe with 7.1 nmol at 90 min)). The most hydrophobic ZnPcDo and the hydrophilic ZnPcMe showed similar accumulation behaviour (2.3 nmol and 3.1 nmol). The water-soluble photosensitizer ZnPcMe showed the lowest tumour accumulation and the longest retention period (6h).

The lipophilic ZnPcDo was evaluated with low accumulation during the studied period (1-6h). The phenomenon of precipitation of a lipophilic drug under physiological condition ($\text{pH} \sim 7$) can provoke an insufficient accumulation into the cells. We found that cationic ZnPcs differing in lipophilicity have specific uptake into B16 pigmented melanoma in dependence on their hydrophilic/lipophilic nature.

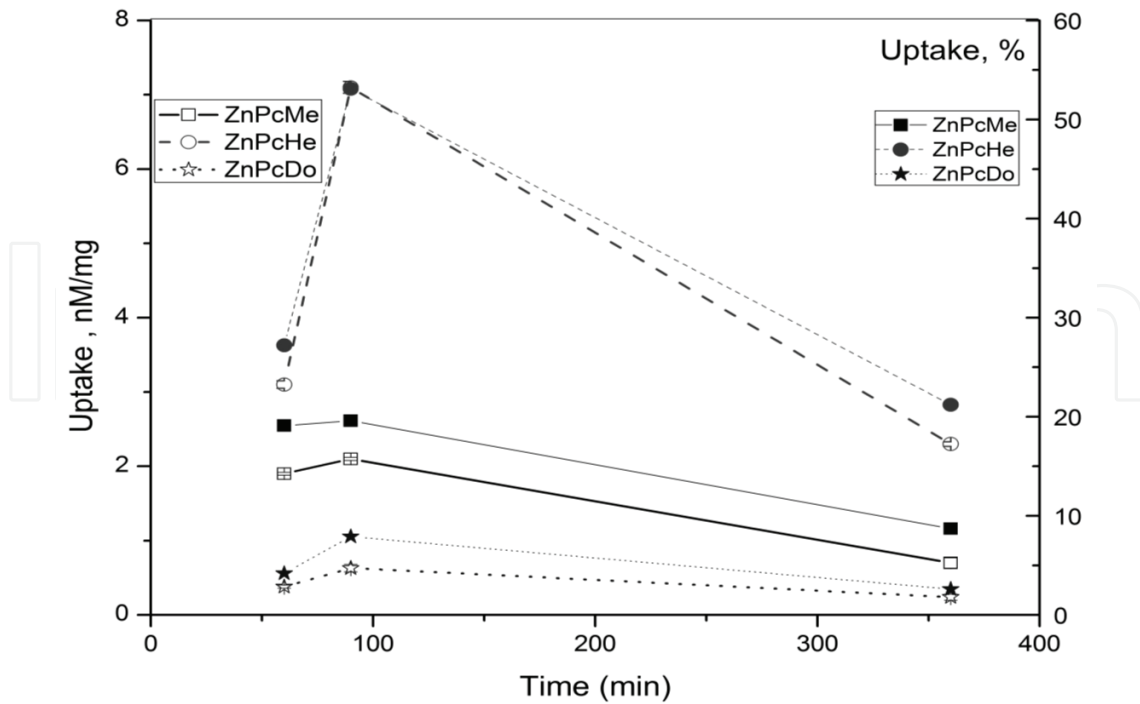

Fig. 4. Tumour uptake of cationic ZnPcs into B16 pigmented melanoma cells presented by ZnPcs concentration

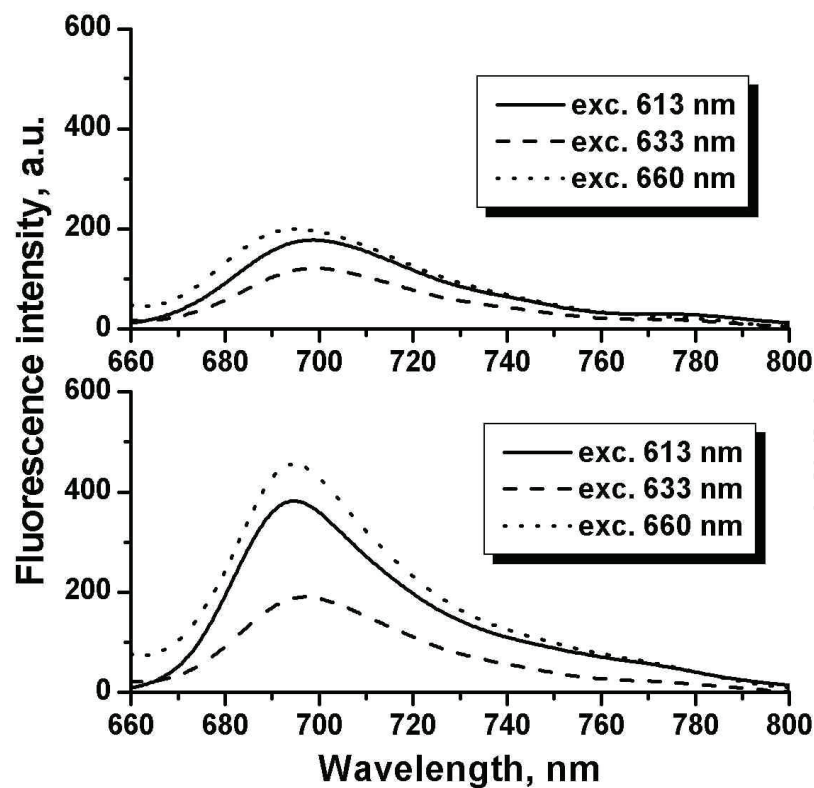

Fig. 5. In vivo fluorescence spectra of healthy (up) and tumour (down) tissues recorded 24 h after i.p. injection of ZnPcHe-DPPC liposomes. The fluorescence spectra are taken at different excitation wavelengths using an Ar-dye laser source (insets)

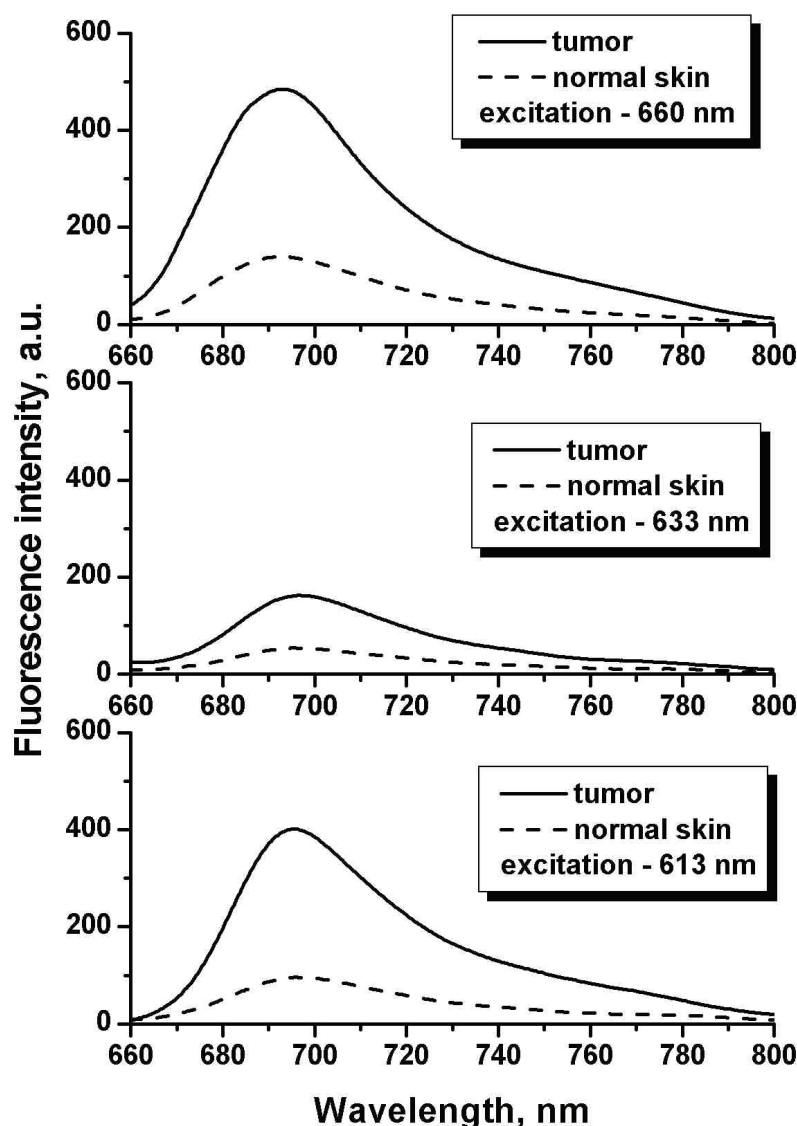

Fig. 6. Comparison of the spectral signals obtained by in vivo fluorescence detection of tumour and healthy tissues recorded 24 h after i.p. injection of ZnPcHe-DPPC liposomes, using different excitation wavelengths (Mantareva et al., 2005)

4.2 Photodiagnosis and photodynamic therapy studies on B16 pigmented melanoma

In the recent photodynamic studies, we prepared differently substituted Zn(II)-phthalocyanines (ZnPcs) to be studied as selective B16 pigmented melanoma cells agents. The hydrophobicity of ZnPcs was evaluated with respect to their selective localizing properties on a B16 tumour model. We were able to demonstrate the effective diagnosis at the early stage of development of pigmented melanoma in an in vivo experiment (Fig. 5 and Fig. 6).

The PDT response of B16 pigmented melanoma implanted on mice was compared for different generations of photosensitizers by varying the treatment parameters. The treatment of pigmented melanomas with naphthalocyanines was successful. The phototoxicity studies performed with liposome-incorporated Zn(II)-phthalocyanine (Ciba-Geigy, Switzerland) and tetrabenzamido-substituted Zn(II)-naphthalocyanine, ZnPcA synthesized for PDT studies revealed a high PDT response (Peeva et al., 1999; Soncin et al., 1998).

4.3 Light dose effects

The effectiveness for treatment of B16 pigmented melanoma of the long-wavelength absorbing benzamido-substituted naphthalocyanine (ZnNcA) was examined due to its strong absorption around 774 nm, which allowed light penetration into the pigmented tissue. It was demonstrated that the phototoxicity of ZnNcA increased as the irradiance was increased up to 380 mW cm⁻², which caused extensive tumour necrosis and substantial delay in the rate of tumour growth with 40 % cure rate (Michailov et al., 1997). A moderate increase of the tumour temperature above the basal value during the treatment can contribute to a better phototherapeutic effect (Fig. 7). The temperature increased above 41 °C at 440 mW.cm-2 and above the higher irradiance of 440 and 500 mW.cm-2 led to a lower PDT response and the possibility of hyperthermia.

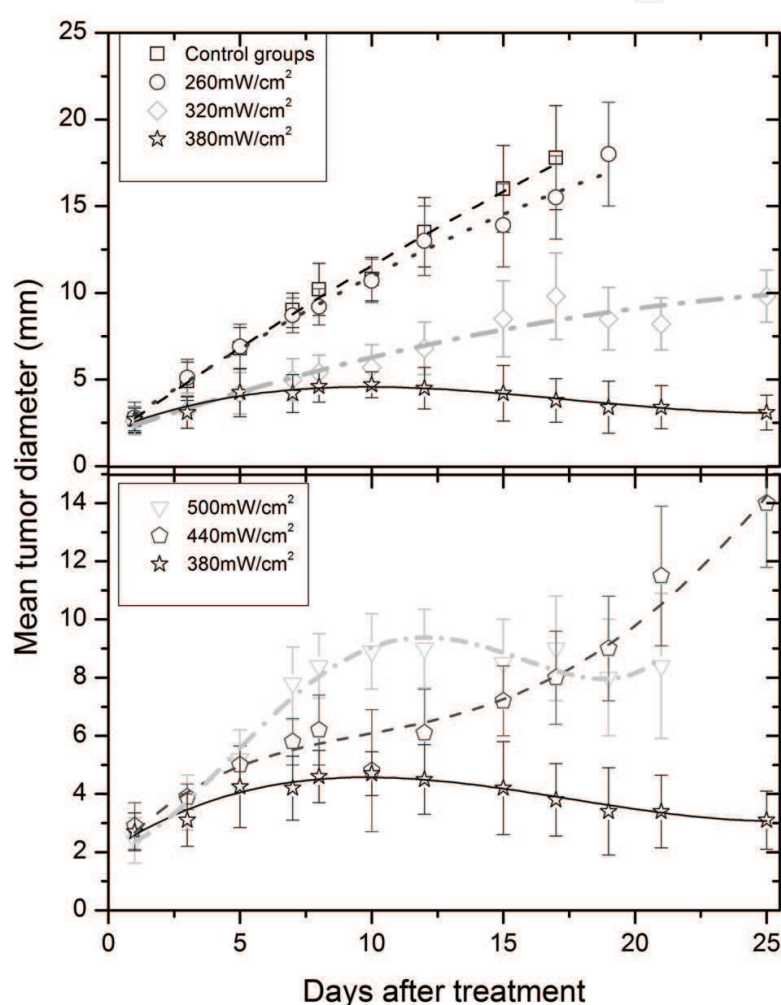

Fig. 7. PDT with ZnNcA (0.5 mg.kg⁻¹ b.w.) on mice with implanted B16 pigmented melanoma as a function of the fluence (exc: 774 nm 24 h after sensitizer administration). Tumour response in mice after PDT treatment at a fluence of 360 J cm⁻² performed 24 h after sensitizer administration (0.5 mg kg⁻¹ b.w.) and 30 min after anesthesia (490 µg/g chloral hydrate). (a) Tumours exposed to 774 nm at fluences of 260, 320 and 380 mW cm⁻². Control groups without sensitizer and irradiation. (b) Tumors exposed to 774 nm at fluences of 440 and 500 mW cm⁻². To facilitate the comparison, the PDT curve for 380 mW cm⁻² irradiation is also given (Michailov et al., Copyright 1997, Elsevier)

5. Conclusions

Photodiagnosis and photodynamic therapy are based on the native tissue chromophores and on the exogenous photosensitizers, which are deposited preferentially into malignant tissues. Excitation with light with appropriate wavelength catalyzes the production of ROSs which induces cytotoxic effects causing irreversible photodamage to tumour tissues (Awan and Tarin, 2006; Davids and Kleemann, 2010; MacDonald, 2011; Foote, 1991). The data collected from preclinical and some clinical observations suggest that the PDT approach appears to be useful in numerous oncological malignancies (Dougherty, 1992; Allison, 2006). Pigmented melanoma is one of the malignancies that are highly aggressive, while the known treatment procedures have poor prognosis. In our in vitro/ in vivo studies on B16 pigmented melanomas, we focused on the improvement of the photosensitizing agents from the group of phthalocyanines and naphthalocyanines and on the applied treatment protocols (Borisova et al., 2005; Rai et al., 2010; Brown et al., 2004). The principal factor which influences the susceptibility of pigmented melanoma to the PDT is the competition between the absorbance of melanin from B16 melanoma and the absorbance of the photosensitizing agent at the excitation wavelength. The porphyrin derivatives Photofrin and HpD have low absorbance at 630 nm where the pigmented tissue absorbs sufficiently; as a result, the PDT response of B16 pigmented melanoma was insignificant (Rai et al., 2010). The studies with photosensitizers absorbing in the far-red region, namely, phthalocyanines and especially naphthalocyanines suggested that the significant level of pigmentation is not an obstacle to applying PDT for diagnosis and therapy of highly pigmented tumours, such as B16 pigmented melanoma. The combined action of the photosensitizing process and the photoinduced hyperthermia can boost the anti-tumour effect. The optimization of the treatment modality concerning pigmented melanoma involves the photodegradation of the pigment as a first step of treatment and further application of PDT with naphthalocyanines or other far-red absorbing sensitizers.

6. Acknowledgements

The studies were supported by EC grants (G5RD-CT-2000-00372, IMPECABLE) and by the National Science Fund, Bulgaria (L 403, DO-02-112/08, DO-02-177/08).

7. References

- Allison R.; Sibata C.; Downie G.; Cuenca R. (2006). A clinical review of PDT for cutaneous malignancies. *Photodiagnosis and Photodynamic Therapy* vol. 3, pp. 214-226, ISSN: 1572-1000.
- Awan, M. A.; Tarin, S. A.; (2006). Review of Photodynamic therapy, *Surgeon*, Vol.4 (4), pp. 231-236. ISSN 1479-666X.
- Borisova E. (2006). Fluorescence detection makes malignant melanoma diagnosis more precise and easier. *SPIE Newsroom*, DOI: 10.1117/2.1200610.0470].
- Borisova E.; Nikolova E.; Troyanova P.; Avramov L. (2008a). Autofluorescence and diffuse reflectance spectroscopy of pigment disorders in human skin, *Journal on optoelectronics and advanced materials* Vol.10 No.3, pp. 717-722, ISSN 1454-4164.
- Borisova E.; Troyanova P.; Pavlova P.; Avramov L. (2008b). Diagnostics of pigmented skin tumours based on laser-induced autofluorescence and diffuse reflectance spectroscopy, *Quantum Electronics* Vol. 38, No.6, pp. 597-605, ISSN 1063-7818.

- Borisova, E.; Angelov, I.; Mantareva, V.; Petrova, D.; Townsend, P.; Valberg, L.; Avramov, L.; (2005). Tumor detection by exogenous fluorescent dyes using new generation photo-multiplier tubes. *Proceedings of SPIE, The International Society of Optics and Photonics*, Vol.5830, pp. 399-403. ISBN: 9780819458223.
- Brown, S. B.; Brown, E. A.; Walker, I.; (2004). The present and the future role of photodynamic therapy in cancer treatment. *Lancet Oncology*, Vol.5, pp. 497-508, ISSN 1470-2045.
- Buseti, A.; Soncin, M.; Jori, G.; Kenney, M. E.; Rodgers, M.A.J.; (1998). Treatment of malignant melanoma by high-peak-power 1064 nm irradiation followed by photodynamic therapy, *Photochemistry and Photobiology*, Vol.68. No.3, pp. 377-381. ISSN 1751-1097.
- Chwirot B.; Chwirot S.; Redzinaski J.; Michniewicz Z. (1998). Detection of Melanomas by Digital Imaging of Spectrally Resolved Ultraviolet Light-induced Autofluorescence of Human Skin. *European Journal of Cancer*, Vol. 34, No. 11, pp. 1730-1734, ISSN 0959-8049.
- Chwirot B.; Chwirot S.; Sypniewska N.; Michniewicz Z.; Redzinski J.; Kurzawski G.; Ruka W. (2001). Fluorescence In Situ Detection of Human Cutaneous Melanoma: Study of Diagnostic Parameters of the Method. *Journal of Investigative Dermatology* Vol. 11, pp.1449-1451, ISSN: 0022-202X.
- Davids, L. M.; Kleemann, B.; (2010). Combating melanoma: The use of photodynamic therapy as a novel, adjuvant therapeutic tool, *Cancer Treatment reviews*, ISSN 0305-7372.
- Dougherty, T. J.; (1992). Photochemistry in the treatment of cancer. *Advances in Photochemistry*. Vol.17, pp. 275-311. ISSN 1934-4570.
- Foote, C. S.; (1991). Definition of type I and type II photosensitized oxidation. *Journal of Photochemistry and Photobiology*, Vol.54, pp. 659-668. ISSN 1010-6030.
- Ibbotson, S. H.; (2010). An overview of topical photodynamic therapy in dermatology. *Photodiagnosis and Photodynamic Therapy*, Vol.7, No.1, pp. 16-23. ISSN 1572-1000.
- Kalka, K.; Merk, H.; Mukhtar, H.; (2000). Photodynamic therapy in dermatology. *Journal of the American Academy of Dermatology*, Vol.42, pp. 389-413. ISSN 0190-9622.
- Kaplan M.; Borgul O.; Zakurdyeva I.; Spichenkova I. (2008). Photodynamic therapy in combined treatment modalities of disseminated melanoma. *Photodiagnosis and Photodynamic Therapy*, Vol. 5, Suppl. 1 - Abstracts of 13th EMLA Congress ed. A. Makela, L. Gasparyan, pp. S9, ISSN: 1572-1000.
- Kolarova H.; Nevrelouva P.; Bajgar R.; Jirova D.; Kejlouva K.; Strnad M. (2007a) In vitro photodynamic therapy on melanoma cell lines with phthalocyanines. *Toxicology in Vitro* vol. 21, pp. 249-253, ISSN 0887-2333.
- Kolarova H.; Lenobel R.; Kolar P.; Strnad M. (2007b) Sensitivity of different cell lines to phototoxic effect of disulfonated chloroaluminium phthalocyanines. *Toxicology in Vitro*, vol. 21, pp.1304-1306, ISSN 0887-2333.
- Kubler A. (2005) Photodynamic therapy. *Medical Laser Applications* Vol.20, pp.37-45, ISSN 1615-1615.
- Leffel D.; Stetz M.; Milstone L.; Deckelbaum L. (1988). In vivo fluorescence of human skin. *Archives in Dermatology* Vol. 124, pp.1514-1518, ISSN 0003-987X.

- Lohmann W.; Nilles M.; Boedeker R. (1991). In situ differentiation between nevi and malignant melanomas by fluorescence measurements. *Naturwissenschaften* Vol. 78, pp. 456-457, ISSN 0028-1042.
- Lohmann W.; Paul E. (1988). In situ detection of melanomas by fluorescence measurements. *Naturwissenschaften*, Vol. 75, Issue 4, pp. 201-202, ISSN 0028-1042.
- MacDonald, I. J.; Dougherty, T. J.; (2001). Basic principles of photodynamic therapy, *Journal of Porphyrines and Phthalocyanines*, Vol.5, pp.105-129. ISSN 1099-1409.
- Mantareva, V.; Petrova, D.; Avramov, L.; Angelov, I.; Borisova, E.; Peeva, M.; Wöhrle, D.; (2005). Long wavelength absorbing cationic Zn(II)-phthalocyanines as fluorescent contrast agents for B16 pigmented melanoma, *Journal of Porphyrins and Phthalocyanines*, Vol.9, No.1, pp.47-53. ISSN 1088-4246.
- Mantareva, V.; Shopova, M.; Spassova, G.; Wöhrle, D.; Müller, S.; Jori, G.; Ricchelli, F.; (1997). Si(IV)-methoxyethylene-glycol-naphthalocyanine: synthesis and pharmacokinetic and photosensitizing properties in different tumour models, *Journal of Photochemistry and Photobiology B: Biology*, Vol.40, pp. 258-262. ISSN 1011-1344.
- Meredith P.; Riesz J. (2004). Radiative relaxation quantum yields for synthetic eumelanin. *Photochemistry and Photobiology*, Vol. 79, issue 2, pp. 211-216, ISSN 1751-1097
- Michailov, N. ; Peeva, M. ; Angelov, I. ; Woehrl, D. ; Mueller, S. ; Jori, G.; Riccelli F. & Shopova, M.; (1997). Fluence rate effects on B16 pigmented melanoma. *Journal of Photochemistry and Photobiology B: Biology*, Vol.37, pp. 154-157, ISSN 1011-1344.
- Nighswander-Rempel S.P.; Riesz J., Gilmore J., Meredith P. (2005). A Quantum Yield Map for Synthetic Eumelanin. *The Journal of Chemical Physics*, Vol. 123, pp. 194901-6, ISSN 1089-7690.
- Peeva, M.; Shopova, M.; Stoichkova, N.; Michailov, N.; Woehrl, D.; Mueller, S.; (1999). Comparative photodynamic therapy of B16 pigmented melanoma with different generations of sensitizers, *Journal of Porphyrines and Phthalocyanines*, Vol.3, pp. 380-387. ISSN 1088-4246.
- Perna G.; Frassanito M.C.; Palazzo G.; Gallone A.; Mallardi A.; Biagi P.F.; V.Capozzi (2009). Fluorescence spectroscopy of synthetic melanin in solution. *Journal of Luminescence* Vol. 129, pp. 44-49, ISSN 0022-2313.
- Rai, P.; Mallidi, S.; Zheng, X.; Rahmzadeh, R.; Mir, Y.; Elrmington, S.; Khurshid, A.; Hasan, T.; (2010). Development and applications of photo-triggered theranostic agents. *Advanced Drug Delivery Reviews*, Vol.62, pp. 1094-1124. ISSN 0169-409X.
- Saczko J.; Kulbacka J.; Chwilkowska A.; Drag-Zalesinska M.; Wysocka T.; Lugovski M.; Banas T. (2005). The influence of photodynamic therapy in apoptosis in human melanoma cell line. *Folia Histochemica Cytobiologica* Vol. 43 issue 3, pp. 129-132, ISSN 1897-5631.
- Shopova, M.; Woehrl, D.; Mantareva V.; & Mueller, S. (1999). Naphthalocyanine-complexes as potential photosensitizers for PDT of tumours, *Journal Biomedical Optics*, Vol.4, No.3, pp. 276-285. ISSN: 1083-3668.
- Soncin, M.; Buseti, A.; Biolo, R.; Jori, G.; Kwag, G.; Li, Y.S.; Kenney, M. E.; Rodgers, M.; (1998). Photoinactivation of amelanotic and melanotic melanoma cells sensitized by axially substituted Si-naphthalocyanines, *Journal of Photochemistry and Photobiology B: Biology*, Vol.42, pp.202-210. ISSN 1011-1344.

- Sounik, J.R.; Schechtman, L.A.; Rihter, B.D.; Ford, W.E.; Rodgers, M.A.J.; Kenney, M.E.; (1990) Synthesis and characterization of naphthalocyanines and phthalocyanines of use in sensitizers studies in: Photodynamic therapy: Mechanisms II, *Proceedings of SPIE, The International Society of Optics and Photonics*, Vol.1203, T.J. Dougherty and A. Katzir (eds.), 224-232. DOI: 10.1117/12.17668.
- Sterenborg H.; Thomsen S.; Jacques S.; Motamedi M. (1995). In vivo autofluorescence of an unpigmented melanoma in mice. Correlation of spectroscopic properties to microscopic structure. *Melanoma Research* Vol.5 No.4, pp. 211-216, ISSN 0960-8931.
- Teuchner K.; Freyer W.; Leupold D.; Volkmer A.; Birch D.; Altmeyer P.; Stucker M.; Hoffmann K. (1999). Femtosecond Two-photon Excited Fluorescence of Melanin. *Photochemistry and photobiology* Vol. 70, pp.146-151, ISSN 1751-1097.
- Woehrle, D.; Mueller, S.; Shopova, M.; Mantareva, V.; Spassova, G.; Vietric, F.; Ricchellid, F.; Jori, G.; (1999). Pharmacokinetic and PDT efficacy of Bis(methoxyethyleneoxy)silicon-phthalocyanine as function of delivery system *Journal of Photochemistry & Photobiology Biology*, Vol.50, pp. 124-128, ISSN 1011-1344.

IntechOpen

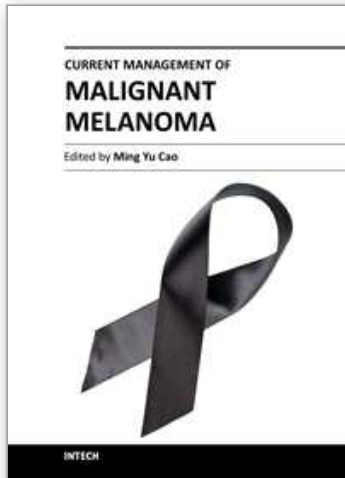

Current Management of Malignant Melanoma

Edited by Dr. Ming Yu Cao

ISBN 978-953-307-264-7

Hard cover, 274 pages

Publisher InTech

Published online 22, September, 2011

Published in print edition September, 2011

Management of melanoma is challenging, especially for the late stage of the disease. Development of new therapies and optimizing current treatments are being pursued in attempt to further improve the survival rate. The book provides up-to-date knowledge and experience in early diagnosis, prevention and treatment of melanoma as well as current ongoing clinical studies on melanoma. The book also provides the most recent perspectives of research on the molecular basis of melanoma, such as melanoma associated genes and a possible link between stress and melanoma.

How to reference

In order to correctly reference this scholarly work, feel free to copy and paste the following:

Ekaterina Borisova, Irina Bliznakova, Vanya Mantareva, Ivan Angelov, Latchezar Avramov and Elmira Petkova (2011). Photodiagnosis and Photodynamic Therapy of Cutaneous Melanoma, Current Management of Malignant Melanoma, Dr. Ming Yu Cao (Ed.), ISBN: 978-953-307-264-7, InTech, Available from: <http://www.intechopen.com/books/current-management-of-malignant-melanoma/photodiagnosis-and-photodynamic-therapy-of-cutaneous-melanoma>

INTECH
open science | open minds

InTech Europe

University Campus STeP Ri
Slavka Krautzeka 83/A
51000 Rijeka, Croatia
Phone: +385 (51) 770 447
Fax: +385 (51) 686 166
www.intechopen.com

InTech China

Unit 405, Office Block, Hotel Equatorial Shanghai
No.65, Yan An Road (West), Shanghai, 200040, China
中国上海市延安西路65号上海国际贵都大饭店办公楼405单元
Phone: +86-21-62489820
Fax: +86-21-62489821

© 2011 The Author(s). Licensee IntechOpen. This chapter is distributed under the terms of the [Creative Commons Attribution-NonCommercial-ShareAlike-3.0 License](#), which permits use, distribution and reproduction for non-commercial purposes, provided the original is properly cited and derivative works building on this content are distributed under the same license.

IntechOpen

IntechOpen