

# We are IntechOpen, the world's leading publisher of Open Access books Built by scientists, for scientists

4,800

Open access books available

122,000

International authors and editors

135M

Downloads

Our authors are among the

154

Countries delivered to

TOP 1%

most cited scientists

12.2%

Contributors from top 500 universities



WEB OF SCIENCE™

Selection of our books indexed in the Book Citation Index  
in Web of Science™ Core Collection (BKCI)

Interested in publishing with us?  
Contact [book.department@intechopen.com](mailto:book.department@intechopen.com)

Numbers displayed above are based on latest data collected.  
For more information visit [www.intechopen.com](http://www.intechopen.com)



## The LDACS1 Link Layer Design

Thomas Gräupl and Max Ehammer  
*University of Salzburg  
Austria*

### 1. Introduction

Air transportation is an important factor for the economic growth of the European Union, however, the current system is already approaching its capacity limits and needs to be reformed to meet the demands of further sustainable development (Commission of the European Communities, 2001). These limitations stem mainly from the current European air traffic control system.

Air traffic control within Europe is fragmented due to political frontiers into regions with different legal, operational, and regulative contexts. This fragmentation decreases the overall capacity of the European air traffic control system and, as the system is currently approaching its capacity limits, causes significant congestion of the airspace. According to the European Commission airspace congestion and the delays caused by it cost airlines between €1.3 and €1.9 billion a year (European Commission, 2011). For this reason, the European Commission agreed to adopt a set of measures on air traffic management to ensure the further growth and sustainable development of European air transportation.

The key enabler of this transformation is the establishment of a Single European Sky<sup>1</sup> (SES). The objective of the SES is to put an end to the fragmentation of the European airspace and to create an efficient and safe airspace without frontiers. This will be accomplished by merging national airspace regions into a single European Flight Information Region (FIR) within which air traffic services will be provided according to the same rules and procedures.

In addition to the fragmentation of the airspace the second limiting factor for the growth of European air transportation lies within the legacy Air Traffic Control (ATC) concept. In the current ATC system, which has been developed during the first half of the twentieth century, aircraft fly on fixed airways and change course only over navigation waypoints (e.g. radio beacons). This causes non-optimal paths as aircraft cannot fly directly to their destination and results in a considerable waste of fuel and time<sup>2</sup>. In addition, it concentrates aircraft onto airways requiring ATC controllers to ascertain their safe separation.

The tactical control of aircraft by ATC controllers generates a high demand of voice communication which is proportional to the amount of air traffic. As voice communication

---

<sup>1</sup>Regulation (EC) No 549/2004 of the European Parliament and of the Council of 10 March 2004.

<sup>2</sup>On average, flight routes within Europe are 49 kilometres too long (European Commission, 2011).

EUROCONTROL reported 9,916,000 IFR (Instrument Flight Rules) flights in 2007 resulting in 485,884,000 unnecessary flight kilometres over Europe.

puts a considerable workload on the human controller the air traffic cannot be increased arbitrarily without compromising the safety of the system. This situation is made worse by the fact that the radio spectrum dedicated to aeronautical voice communication is becoming increasingly saturated i.e. even if the human controllers could cope with more air traffic safely, there would not be enough voice frequencies to do so. Excessive controller workload and voice frequency depletion are therefore the main technical problems of the current air traffic control system.

The introduction of advanced Air Traffic Management (ATM) procedures and automated support tools will significantly decrease the controller workload. However, advanced ATM requires aircraft to be equipped with accurate position determination and collision avoidance equipment as well as data communications to integrate them into the ATM, System Wide Information Management (SWIM) and Collaborative Decision Making (CDM) processes (Helfrick, 2007).

Data communications is required as ATM transfers parts of the decision making from air traffic controllers to cockpit crews supported by automated procedures and algorithms (e.g. self-separation). The aircrews must now be provided with timely, accurate, and sufficient data to gain the situational awareness necessary to effectively collaborate in the collaborative decision making process of ATM. This requires the availability of sufficiently capable data links. However, the data link solutions available today cannot provide the capacity and quality of service required for the envisaged system wide information management (Eleventh Air Navigation Conference, 2003). Improved air-ground communication has therefore been identified as one key enabler in the transformation of the current air transportation system to an ATM based Single European Sky.

## 2. Development of LDACS1

Today's air-ground communication system is based on analogue VHF voice transmission and is used for tactical aircraft guidance. It is supplemented by several types of aeronautical data links that are also operated in the VHF COM band, most notably ACARS (FANS 1/A) and VHF Digital Link Mode 2.

However, these data links are scarcely deployed. Their further deployment is blocked by the fact that the VHF band is already heavily used by voice communication and is anticipated to become increasingly saturated in high density areas (Kamali, 2010). Introducing additional communication systems into the same frequency band will therefore increase the pressure on the existing infrastructure even further. ACARS and VDL Mode 2 can therefore not provide a viable upgrade path to ATM.

At the eleventh ICAO Air Navigation Conference in 2003 it has therefore been agreed that the aeronautical air-ground communications infrastructure has to evolve in order to provide the capacity and quality of service required to support the evolving air traffic management requirements.

It was the position of the airlines (represented by IATA) that the "air-ground infrastructure should converge to a single globally harmonized, compatible and interoperable system" (IATA, 2003). Thus FAA and EUROCONTROL, representing the regions feeling the most pressure to reform their air-ground communication infrastructure, initiated the Action Plan (AP17) activity to jointly identify and assess candidates for future aeronautical communication systems (EUROCONTROL & FAA, 2007a). This activity was coordinated with the relevant stakeholders in the U.S. (Joint Planning and Development Office Next

Generation Air Transportation System; NextGen) and in Europe (Single European Sky ATM Research; SESAR).

Action Plan 17 concluded in November 2007 and comprised six technical tasks and three business tasks. The business tasks are not of relevance in the context of this chapter, however, the technical tasks were:

- Task 1: Improvements to current systems - frequency management
- Task 2: Identify the mobile communication operational concept
- Task 3: Investigate new technologies for mobile communication
- Task 4: Identify the communication roadmap
- Task 5: Investigate feasibility of airborne communication flexible architecture
- Task 6: Identify the Spectrum bands for new system

The data link technology discussed in this chapter (LDACS1) was developed as input to AP17 Task 3 and its follow-up activities (Gräupl et al., 2009). As one follow-up activity to AP17, EUROCONTROL funded the development and first specification of the LDACS1 system. Although there was no formal cooperation between EUROCONTROL and FAA at this point (AP17 had already been concluded) the development of LDACS1 was observed and advised by FAA and its sub-contractors NASA, ITT and the MITRE cooperation (Budinger et al., 2011).

After the end of the EUROCONTROL funded initial specification the development of the LDACS1 technology was continued in the “Consolidated LDACS1 based on B-AMC” CoLB project of the Austrian research promotion agency FFG as part of the TAKEOFF program. This project produced an updated specification and extensive guidance material. The overview paper (Kamali, 2010) provides an independent summary of the development of the L-DACS systems up to the year 2010. In 2011 the development of LDACS1 was continued in the framework of the SESAR Programme (Sajatovic et al., 2011).

## 2.1 Design goals

The primary design goals of the LDACS1 technology proposal were defined by the high level objectives formulated in AP17 (Fistas, 2009):

- The system development shall be facilitated and expedited through the choice of appropriate components and mature standards.
- The new system should be capable to operate in the L-band without interfering with existing users of the band.
- The system performance should meet the requirements defined in AP17 technical task 2.

The reason for the first design goal was the target deployment year of the future radio system, 2020. The aeronautical industry has comparatively long deployment cycles: In the past the deployment of safety related communication systems has taken between 8 to 15 years i.e. it is required that any future radio system candidate has already achieved a sufficiently high maturity by now, if its initial deployment shall begin by 2015. Starting deployment in 2015 shall allow for a period of pre-operational use before operational service starts in 2020.

Meeting the requirements defined in AP17 technical task 2 requires to support operational aeronautical communication i.e. Air Traffic Services (ATS) and Aeronautical Operational Control (AOC) communications. ATS communication provides navigation, control and situational awareness, while AOC communication is used to perform the business

operations of the airline. The system shall be capable to provide simultaneous ATS and AOC communication with adequate performance as of 2020 and beyond. Due to regulatory reasons passenger communication is out of scope of LDACS1.

These three high level objectives of AP17 were augmented by a number of non-technical, legal and political requirements, which are not discussed here. Within this chapter only the design aspects and evaluation criteria related to the performance of the system are discussed in detail. This was reflected in the identification of five relevant design goals.

**Responsiveness** is the capability of the system to react to communication demand in accordance with given requirements. This comprises the ability to deliver data traffic within specified delays and to provide swift voice service with minimum latency.

**Reliability** is the ability of the system to transmit data without losing or duplicating information. The required level of reliability is expressed in terms of service continuity.

**Scalability** is required for the future radio system in order to handle growing amounts of data traffic and users i.e. the technology should support as many use cases identified in AP17 technical task 2 as possible with acceptable quality of service.

**Efficient resource usage** of the new system is dictated by the scarcity of the available spectrum. This implies avoiding unnecessary protocol overhead (e.g. finding the right balance between forward error correction and backward error correction) and fair distribution of channel resources among users with the same priority.

**Resilience** is the ability of the future radio system to provide and maintain an acceptable quality of service even under adverse conditions. In particular this refers to periods of excessive load and high numbers of users. The system shall behave predictable and, if it fails, this must be detected early and reported immediately.

Of the five design goals presented above only the first three are discussed in detail in this chapter. The last two are touched only briefly. Note that the Communications Operating Concepts and Requirements (COCRv2) document (EUROCONTROL & FAA, 2007b), which was another output of AP17 technical task 2, defines validation criteria for one-way latency (TT95-1 way), continuity, integrity, and availability. These criteria define the target parameters of the L-DACS design and are related to the validation parameters discussed in section 4.3.

### 3. Design analysis

LDACS1 was designed to provide an air-ground data link with optional support for digital air-ground voice. It is optimized for data communication and designed to simultaneously support ATS and AOC communications services as defined in EUROCONTROL's and FAA's "Communication Operating Concept and Requirements for the Future Radio System" (EUROCONTROL & FAA, 2007b).

The key features of LDACS1 are:

- Cellular radio system with up to 512 users per cell. Up to 200 nautical miles range.
- Frequency division duplex with adaptive coding and modulation providing from 303.3 kbit/s up to 1,373.3 kbit/s in each direction.
- Acknowledged and unacknowledged point-to-point communication between ground-station and aircraft-station.
- Unacknowledged multicast communication between ground-station and aircraft-stations (ground-to-air direction only).

- Hierarchical sub-network architecture with transparent handovers between radio cells. This chapter discusses only the protocols of the wireless part of the LDACS1 system i.e. the air interface between the ground-station and the aircraft-station. Physical layer details, sub-network architecture, cell entry, and handovers are not discussed here.

### 3.1 Functional architecture

The LDACS1 air-ground communication architecture is a cellular point-to-multipoint system with a star-topology where aircraft-stations are connected to a ground-station via a full duplex radio link. The ground-station is the centralized instance controlling the air-ground communications within a certain volume of space called an LDACS1 cell. The LDACS1 protocol stack defines two layers, physical layer and data link layer (comprising two sub-layers itself) as illustrated in Fig. 1.

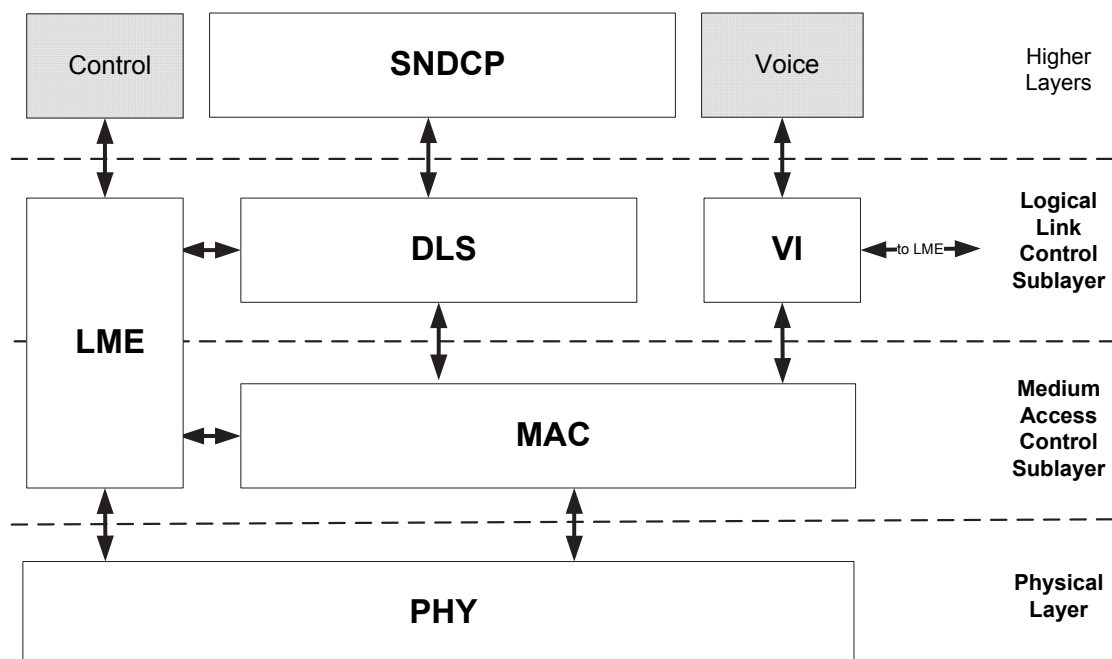

Fig. 1. LDACS1 protocol stack.

The physical layer provides the means to transfer data over the radio channel. The LDACS1 ground-station simultaneously supports bi-directional links to multiple aircraft-stations under its control. The forward link direction (FL; ground-to-air) and the reverse link direction (RL; air-to-ground) are separated by frequency division duplex (FDD). In the RL direction different aircraft-stations are separated in time (using time division multiple access; TDMA) and frequency (using orthogonal frequency division multiple access; OFDMA).

The ground-station transmits a continuously stream of OFDM symbols on the forward link. Aircraft-stations transmit discontinuous on the RL with radio bursts sent in precisely defined transmission opportunities using resources allocated by the ground-station. An aircraft-station accesses the RL channel autonomously only during cell-entry. All other reverse link transmissions, including control and user data, are scheduled and controlled by the ground-station.

The data-link layer provides the necessary protocols to facilitate concurrent and reliable data transfer for multiple users. The functional blocks of the LDACS1 data link layer architecture

are organized in two sub-layers: The medium access sub-layer and the logical link control sub-layer (LLC). The logical link control sub-layer manages the radio link and offers a bearer service with different classes of service to the higher layers. It comprises the Data Link Services (DLS), and the Voice Interface (VI). The medium access sub-layer contains only the Medium Access (MAC) entity. Cross-layer management is provided by the Link Management Entity (LME). The Sub-Network Dependent Convergence Protocol (SNDCP) provides the interface to the higher layers.

The MAC entity of the medium access sub-layer manages the access of the LLC entities to the resources of the physical layer. It provides the logical link control sub-layer with the ability to transmit user and control data over logical channels. The peer LLC entities communicate only over logical channels and have no concept of the underlying physical layer.

Prior to fully utilizing the system, an aircraft-station has to register at the controlling ground-station in order to get a statically assigned dedicated control channel for the exchange of control data with the ground-station. The ground-station dynamically allocates the resources for user data channels according to the current demand as signalled by the aircraft-stations.

Except for the initial cell-entry procedure all communication between the aircraft-stations and the controlling ground-station (including procedures for requesting and allocating resources for user data transmission and retransmission timer management), is fully deterministic and managed by the ground-station. Under constant load, the system performance depends only on the number of aircraft-stations serviced by the particular ground-station and linearly decreases with increasing number of aircraft.

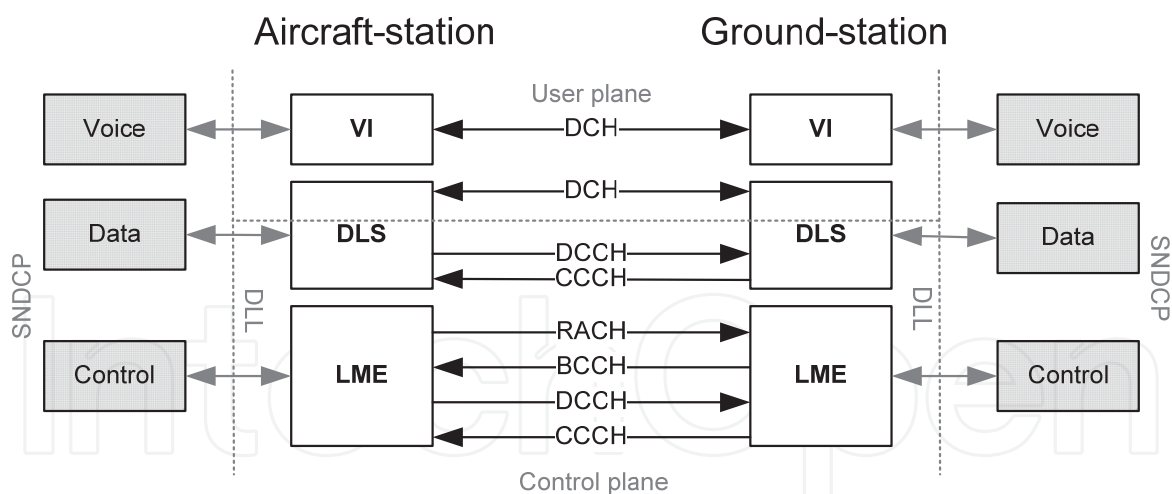

Fig. 2. L- DACS 1 logical channel structure.

Bidirectional exchange of user data between the ground-station and the aircraft-station is performed by the Data Link Service (DLS) entity using the logical data channel (DCH) for user plane transmissions<sup>3</sup>. Control plane transmissions from the aircraft-station to the ground-station are performed over the logical dedicated control channel (DCCH). Ground-to-air control information is transmitted in the common control channel. The random access

<sup>3</sup>Note that the Voice Interface (VI) also uses the DCH for its transmissions.

channel (RACH) and the broadcast control channel (BCCH) are used for cell-entry, cell-exit, and handover. The relation of the logical channels to the functional blocks of the LDACS1 logical link control layer is illustrated in Fig. 2.

The Data Link Service (DLS) provides the acknowledged and unacknowledged exchange of user data over the point-to-point reverse link or point-to-multipoint forward link. There is one DLS in the aircraft-station and one peer DLS for each aircraft-station in the ground-station.

The ground-station Link Management Entity (LME) provides centralized resource management for LDACS1. It assigns transmission resources, provides mobility management and link maintenance. It assigns forward link and reverse link resources taking channel occupancy limitations (e.g. limiting the aircraft-station duty cycle to minimize co-site interference) into account. In addition, the LME provides dynamic link maintenance services (power, frequency and time adjustments) and supports Adaptive Coding and Modulation (ACM).

The Voice Interface (VI) provides support for virtual voice circuits. The voice interface provides only the transmission and reception services, while LME performs creation and selection of voice circuits. Voice circuits may either be set-up permanently by the ground-station LME to emulate party-line voice or may be created on demand.

LDACS1 shall become a sub-network of the Aeronautical Telecommunications Network (ATN). The Subnetwork Dependent Convergence Protocol (SNDTCP) provides the LDACS1 interface to the network layer and a network layer adaptation service required for transparent transfer of Network layer Protocol Data Units (N-PDUs) of possibly different network protocols (ATN/IPS and ATN/OSI). The SNDTCP should also provide compression and encryption services required for improving and securing the wireless channel.

### 3.2 Input from other systems

Most features of the LDACS1 data link layer design are based on the experience gained from the precursor system B-AMC (Rokitansky et al., 2007). The most important protocol element adopted from B-AMC is the medium access approach. The protocol stack architecture and the data link service protocol were redesigned on the basis of the lessons learnt from B-AMC.

However, a considerable amount of input was also received from other AP17 candidate systems. Probably the most influential external input<sup>4</sup> to the LDACS1 design came from the TIA-902 P34 standard. The message formats of the medium access layer and the addressing scheme were directly derived from this system (Haindl et al., 2009). The concept of OFDM tiles and FL and RL allocation maps was adopted from the WiMAX standard. Additional input from WiMAX has gone into the design of the physical layer.

### 3.3 Physical layer overview

LDACS1 is intended to operate in 500 KHz wide channels located in the 1 MHz gaps between adjacent DME<sup>5</sup> channels in the L-band. This type of design is called an inlay system. Inlay systems and similar methods of utilizing “white”-space spectrum are an approach to frequency allocation receiving increased interest, as finding free (“green”) spectrum

---

<sup>4</sup>Kindly supported by FAA, NASA, MITRE, and ITT.

<sup>5</sup>Distant Measuring Equipment (DME) is an aeronautical radio navigation system.



becomes progressively more difficult. LDACS1 shall cover the needs for aeronautical data communication well beyond the year 2030. Therefore it is necessary to make as much bandwidth as possible available to the system. As the L-band is already crowded by other aeronautical and military systems, an inlay concept not requiring any green spectrum is an attractive approach.<sup>6</sup>

However, designing and deploying an inlay technology is a non-trivial matter as co-existence with legacy systems has to be ensured. The problem of co-existence can be decomposed into two parts: Interference from the inlay system towards the legacy systems and interference from the legacy systems towards the inlay system.

Naturally the new system must not disturb the operation of the existing infrastructure. The legacy systems can, however, not be modified, thus, the inlay system has to carry most of this burden. LDACS1 uses a powerful combination of different methods for side-lobe suppression and reduction of out-of-band radiation described in (Brandes, 2009).

The second part of the problem is to design the inlay system robust against interference from existing systems. This is a non-trivial task as many deployed legacy systems have sub-optimal interference characteristics according to modern standards. Most inlay designs therefore try to mitigate the interference of the existing system using sophisticated signal processing and error correcting codes. This is also the approach taken by LDACS1.

The two parts of the co-existence problem cannot be seen in isolation. Any approach to one of both problems has consequences for the other. Therefore it is necessary to find an integrated solution. Depending on the efficiency of the mutual interference suppression two types of inlay systems are possible: The first type is an inlay system that can be deployed completely independent of existing systems. This is an ideal case that can seldom be achieved. The second type of inlay system requires a certain level of coordination.

Close inspection of L-band spectrum usage reveals that the range from 962 MHz to 1025 MHz and 1150 MHz to 1213 MHz is used only for DME reply channels i.e. only the DME transponder sites will use these frequencies for transmissions. Therefore it can be assumed that an LDACS1 ground-station transmitting in the same region will most likely not disturb a nearby (in terms of frequency and distance) airborne DME receiver. Consequently, as a first measure to reduce interference between both systems, LDACS1 was designed as a Frequency Division Duplex (FDD) system<sup>7</sup>. The LDACS1 forward link (FL; ground-to-air) is transmitted in the same region of spectrum as the DME reply (i.e. ground-to-air) channels, from 985 MHz to 1009 MHz. This respects safety margins for the universal access transceiver (UAT), secondary surveillance radar (SSR), and global navigation satellite systems.

Finding an appropriate spectrum allocation for the LDACS1 Reverse Link (RL; air-to-ground) is less obvious as there is no region exclusively in use by DME interrogation channels. Respecting safety margins for the critical systems, two candidate intervals remain: 1048 MHz to 1072 MHz and 1111 MHz to 1135 MHz. As the first option is currently less used by DME, the LDACS1 RL has been allocated in this region (1048 MHz to 1072 MHz). This allows for 24 L-DACS1 FDD channel pairs. The second region is considered as optional extension for now.

The LDACS1 OFDM parameters were chosen according to the characteristics of the aeronautical mobile L-band channel (Brandes, 2009). The forward link and reverse link

---

<sup>6</sup> Note, however, that L-DACS1 can also be deployed in green spectrum without any changes to the technology.

<sup>7</sup> Another reason for the use of FDD was to avoid the large guard interval required between the FL and RL section of TDD.

channels have an effective bandwidth of 498.05 kHz each. Within that bandwidth, 50 OFDM sub-carriers are placed, separated by 9.765625 kHz. Each sub-carrier is separately modulated with a symbol duration of  $T_s = 120 \mu\text{s}$ .

LDACS1 employs concatenated block coding and Reed-Solomon coding in the physical layer. Using the default coding and modulation<sup>8</sup> (QPSK, coding rate 0.45) LDACS1 provides a data rate of 303.3 kbit/s in each direction. Using more aggressive coding and modulation schemes this can be increased up to 1373.3 kbit/s (64QAM, coding rate 0.68) in each direction. Different aircraft-stations may employ different coding and modulation schemes using adaptive coding and modulation (ACM).

The physical layer design includes propagation guard times sufficient for a maximum range of 200 nautical miles. In real deployments the LDACS1 maximum transmission power may, however, have to be limited in order to protect receivers of other L-band systems.

### 3.3.1 Frame structure

The LDACS1 protocol structures the physical layer on the basis of OFDM frames. Frames are combined into multi-frames and super-frames. The LDACS1 super-frame is the highest element of the physical layer framing hierarchy. The super-frame duration is 240 milliseconds or 2000 OFDM symbols. This is a multiple of the voice sample length (20 milliseconds) produced by the AMBE ATC10B vocoder<sup>9</sup>. A forward link super-frame comprises a broadcast control frame BC sub-divided into the BC1, BC2, and BC3 sub-frames and four multi-frames. A reverse link super-frame comprises two random-access opportunities in the random access RA frame and four multi-frames. The super-frame layout is illustrated in Fig. 3 and Fig. 4.

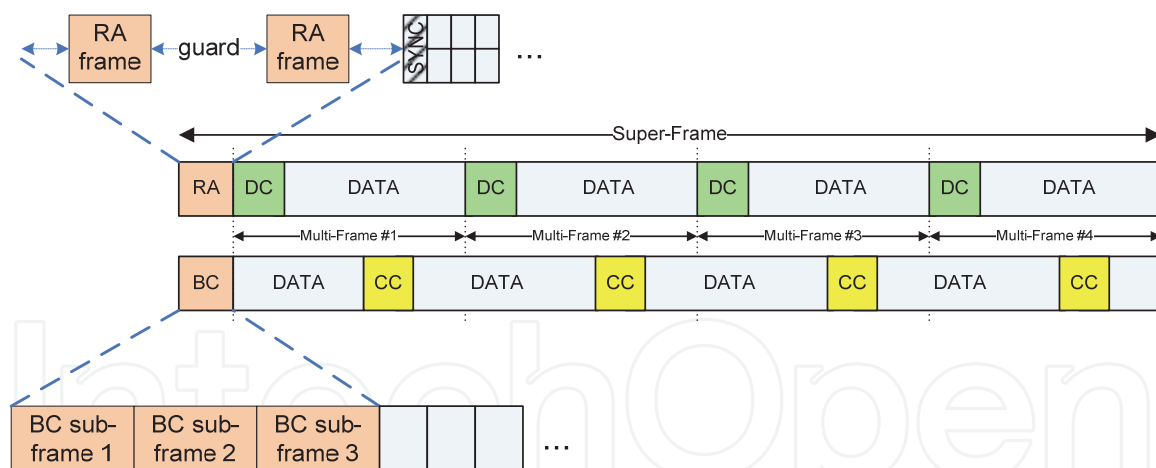

Fig. 3. LDACS1 super-frame structure.

The length of the forward link and reverse link multi-frames is 58.32 milliseconds or 486 symbols. Each forward link multi-frame comprises 9 Data OFDM frames. A variable number of these frames, starting with the fifth data frame, use a different channel coding and are designated as common control CC frames.

<sup>8</sup> The default coding and modulation was designed with the maximum DME sending rate (3600 pulse pairs per second) in mind.

<sup>9</sup>The AMBE ATC10B vocoder is the only digital vocoder currently certified for operational use in aeronautics.

Each RL Multi-Frame (MF) comprises one dedicated control DC slot and one Data slot. These slots are sub-divided into tiles. The reverse link DC slot starts with the RL synchronization symbols and the first two reverse link tiles. Its length is variable between two tiles and fifty-two tiles. The remaining RL tiles create the reverse link data slot.

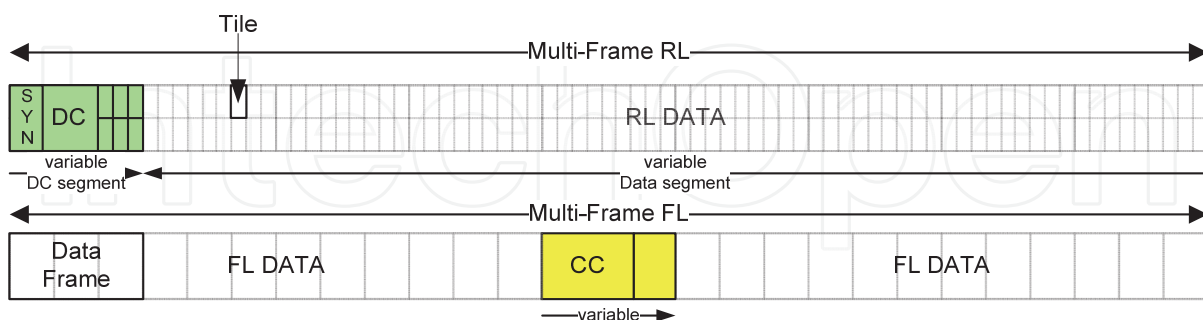

Fig. 4. LDACS1 multi-frame structure.

### 3.4 Medium access sub-layer

The MAC entity of the medium access sub-layer manages the access of the logical link control entities to the resources of the physical layer. The medium access sub-layer provides the logical link control sub-layer with the ability to transmit user and control data in logical channels.

#### 3.4.1 Medium access

The medium access service supports the transmission of user and control data over logical channels. It manages the access of the logical link control sub-layer entities (DLS, LME, and VI) to the time slots conveying the logical channels. The broadcast control channel (BCCH) and the random access channel (RACH) are mapped to the BC and RA slots, respectively. The common control channel (CCCH) is conveyed in the CC slot of the forward link, the dedicated control channel (DCCH) in the DC slot of the reverse link. The forward and reverse data channels (DCH) are mapped to the corresponding data slots of the frame structure.

Since the forward link is exclusively used by the ground-station, no sophisticated multiple access scheme is required in this direction. The ground-station is the only user of the FL time slots. It can therefore allocate FL channel resources (i.e. bytes in the continuous FL transmission) locally according to the required quality of service. This allocation is announced to the aircraft-stations in the common control channel CCCH.

The RL uses a bandwidth on demand scheme. Aircraft-stations have to request channel resources (i.e. RL tiles) from the ground-station before they can transmit their data channel DCH in the RL Data slot. To this purpose aircraft-stations are polled by the ground-station for their resource request in round-robin. Up to 52 aircraft can be polled in one multi-frame. This approach makes resource requests deterministic and contention free. This procedure is illustrated in Fig. 5. Note that the size of the DC slot is variable. It can therefore be increased to provide the capacity necessary to transmit all resource requests.

The resource request is an aggregate request for all resources needed by the aircraft-station. The ground-station assigns resources according to the required quality of service using an appropriate scheduling algorithm. It has to keep track of allocations to avoid duplicate assignments. The coding and modulation of tiles in the RL Data slot can either be fixed for

the entire LDACS1 cell or be changed dynamically by the ground-station LME. The concept of the FL and RL resource allocation is illustrated in Fig. 6. Note that the size of the CC slot is variable. It can therefore be increased to provide the capacity necessary to transmit all resource allocations.

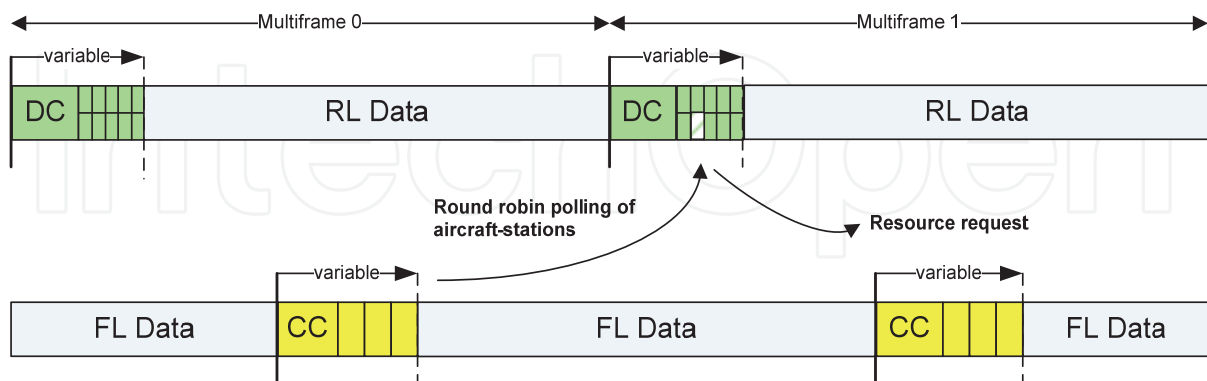

Fig. 5. RL resource request over the DCCH.

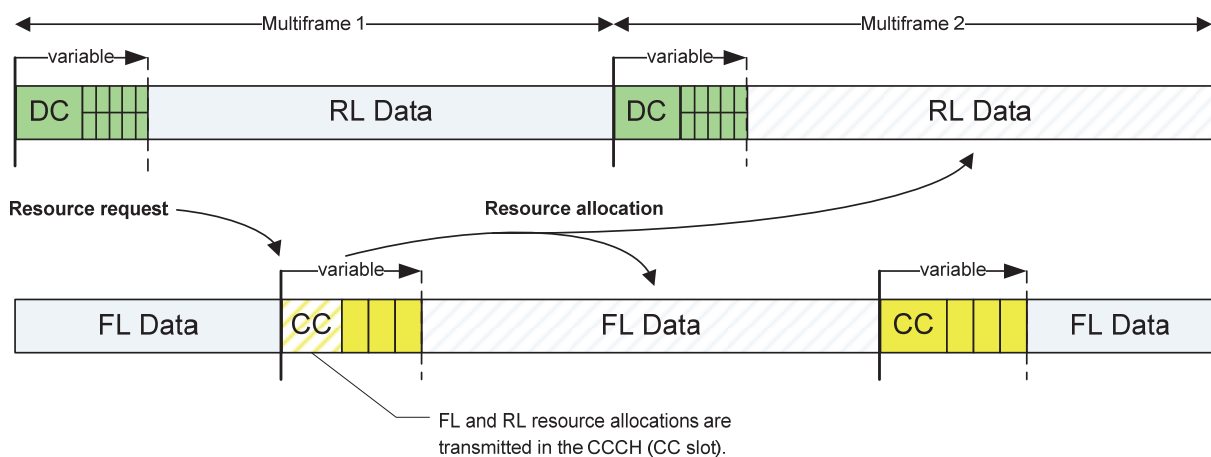

Fig. 6. RL resource allocation over the CCCH.

The LDACS1 medium access sub-layer does neither generate nor process the control messages (resource requests, resource allocations, etc.) transferred over the RACH, BCCH, DCCH and CCCH itself. Resource requests, resource allocations, acknowledgements, etc. are generated and consumed only by the LLC sub-layer. The format of these control messages is specific for each logical channel and documented in the LDACS1 specification (Sajatovic et al., 2011). The only exceptions from this rule are the FL and RL resource allocations of the CCCH, which are stored in the MAC. This is done to ensure that outgoing data is transmitted correctly (i.e. with the assigned coding and modulation) and to determine the source of incoming transmissions from the allocations.

### 3.4.2 Medium access analysis

The size of the CC and DC slots are variable. The optimal CC slot length is the smallest number of CC OFDM frames sufficient to convey all forward link control messages. Determining the optimal DC slot size is less trivial, however, the minimum DC slot size can be derived from the 95% percentile latency requirements (see Section 4.3) according to the

following design approach: If the physical layer is configured to provide a DLS packet error rate of less than five percent, 95% of the DLS packets can be delivered without a retransmission. The 95% percentile of the higher layer latency is then (approximately) equal to the MAC latency in this case i.e. if the MAC latency can be given as a function of the DC slot length, the minimum DC slot length can be derived from the 95% latency requirements<sup>10</sup> given in section 4.3.

The duration of a RL transmission  $T_{X_{RL}}$  is bounded by

$$T_{X_{RL}} \leq T_{X_{MAC}} + T_{X_{Transmission}} \quad (1)$$

where  $T_{MAC}$  is the medium access latency (resource request + resource allocation), and  $T_{Transmission}$  is the transmission time of the data itself.

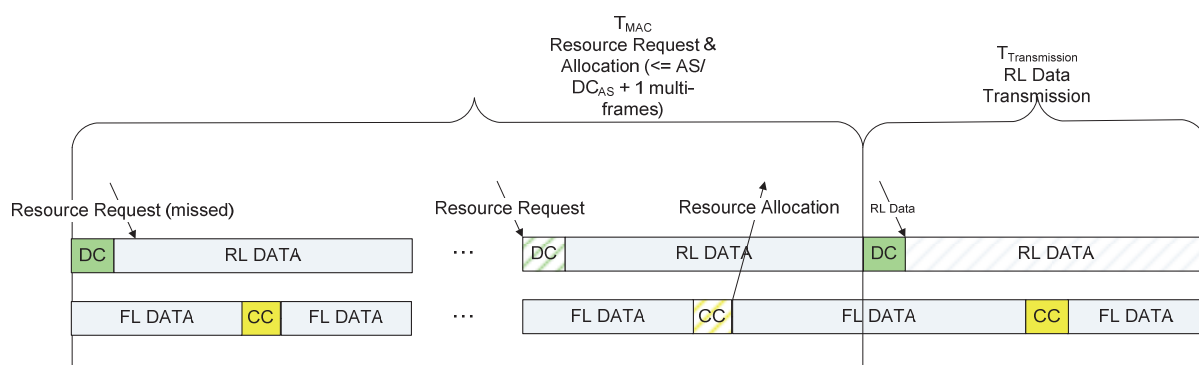

Fig. 7. Maximum length of RL packet transmission.

An aircraft-station can send a resource request in the DC slot only when it is polled. In the worst case, if the aircraft-station just missed this time slot, it has to wait for the current multi-frame and one complete reservation cycle (i.e. the time until it is polled again in round robin) to make a request. This is illustrated in Fig. 7. The corresponding resource allocation should<sup>11</sup> be transmitted in the next CC slot, which is within the last multi-frame of the reservation cycle. Thus  $T_{MAC}$  is bounded by the length of the reservation cycle.

$$T_{MAC} \leq \left\lceil \frac{AS}{DC_{AS}} \cdot MF \right\rceil + MF \quad (2)$$

where  $AS$  is the number of registered aircraft stations,  $DC_{AS}$  is the number of aircraft stations polled per DC, and  $MF$  is the average length of the multi-frame (60 milliseconds neglecting the RA/BC slot).

It is assumed that RL packets is small enough to be transmitted in one multi-frame i.e.  $T_{Transmission} = 60$  milliseconds. Under the assumption that the packet error rate is less than 5% the 95% percentile of  $T_{X_{RL}}$  will then be below

<sup>10</sup>This approach neglects the fragmentation of large higher layer packets. However, as the most stringent latency requirements apply to the smallest packets, it is suitable to provide a valid estimate of the minimum DC slot size.

<sup>11</sup>Sending the allocation in the next CC is not strictly required in the specification, but strongly recommended in the LDACS1 guidance material. If the system is not overloaded there is, however, no reason to delay the allocation anyway.

$$T_{RL95} \leq \left\lceil \frac{AS}{DC_{AS}} \cdot MF \right\rceil + 2 \cdot MF \quad (3)$$

as 95% of the packets will be successfully transmitted in this time. The 5% erroneous packets require additional time for a retransmission.

Putting the equations together the DC slot length required to meet a 95% percentile requirement  $L$  can be calculated from:

$$T_{RL95} \leq \left\lceil \frac{AS}{DC_{AS}} \cdot MF \right\rceil + 2 \cdot MF \leq L \quad (4)$$

The minimum DC slot length to meet the requirement  $L$  with  $AS$  aircraft stations is thus:

$$DC_{AS} \geq \frac{MF \cdot AS}{L - 2 \cdot MF} \quad (5)$$

This formula can now be used to derive the minimum DC slot length necessary to support a given 95% latency requirement. The results of this calculation for the evaluation scenarios of Section 4.1 and the requirements in Table 4 of section 4.3 are displayed in Table 1. Note that all minimum slot lengths are below the maximum physical layer DC slot size of 52 tiles i.e. the formal analysis indicates that the LDACS1 medium access sub-layer design scales to fulfil the defined latency requirements.

Scenario <sup>12</sup>	Number of aircraft (PIAC)	Minimum DC slot size (tiles)			
		ATS Only, with A-EXEC	ATS+AOC, with A-EXEC	ATS Only, without A-EXEC	ATS+AOC, without A-EXEC
APTZone	26	-	-	2	2
APTSurface	264	-	-	13	13
TMASmall	44	5	5	3	3
TMALarge	53	6	6	3	3
ENRSmall	45	5	5	3	3
ENRMedium	62	6	6	3	3
ENRLarge	204	20	20	10	10
ENRSuperLarge	512	50	50	24	24

Table 1. LDACS1 minimum DC slot size in tiles.

### 3.5 Logical link control sub-layer

The logical link control sub-layer contains the necessary protocols to facilitate reliable data transfer for multiple users. It comprises the Data Link Service (DLS) and the Link Management Entity (LME).

<sup>12</sup>Scenarios are discussed in Section 4.1.

### 3.5.1 Data link service analysis

The DLS has two major functions: First the segmentation and reassembly of higher layer packets. Second the acknowledged and unacknowledged transmission of (fragmented) higher layer packets. In addition, the DLS performs the local quality of service management using separate queues for different service classes. If a resource grant is received, the input queues are served according to their priorities. Higher priority traffic classes may pre-empt lower priority classes. This guarantees high priority queues to get prioritised medium access.

The design of the reliable DLS protocol had to be carried out taking two main requirements into consideration: Reliability and responsiveness. Reliability is formalized by the notion of continuity i.e. it is linked with the detection and recovery of lost and duplicated packets. The analysis below indicates under which conditions ARQ is required to ensure the stated continuity requirements and justifies the use of ARQ in LDACS1.

High levels of continuity can either be achieved by the application of error correcting codes (Forward Error Correction; FEC), the retransmission of erroneous packets (Automatic Repeat request; ARQ; sometimes also called backward error correction), or a combination of both approaches (Hybrid ARQ; HARQ). The continuity  $c$  that can be achieved using these approaches can be calculated by

$$c(p, R) = \sum_{n=0}^R (1-p)^n p^n \quad (6)$$

if the higher layer message is small enough to be conveyed in a single packet. The variable  $p$  is the effective packet error rate after FEC (if forward error correction is applied). The variable  $R$  is the maximum number of retransmissions supported by the ARQ protocol. Note that  $R=0$  is equivalent to not using ARQ.

For large higher layer messages that need to be transmitted in  $m$  fragments continuity is given by

$$c(p, R, m) = c(p, R)^m \quad (7)$$

This analytical model can now be applied to the data link services of AP17 technical task 2 on which the requirements of section 4.3 are based. Fig. 8 plots the achievable continuity for these services without using ARQ. The dashed horizontal line denotes the continuity requirement of the investigated services (99.96%, 99.996%, and 99.999992% in Fig. 8 (a), (b), and (c), respectively), the dashed vertical line indicates the expected bit error rate of the LDACS1 physical layer ( $10^{-5}$ ) i.e. the continuity requirement is fulfilled by LDACS1 if the continuity curve of each COCRv2 service intersects with the dashed horizontal line right of the dashed vertical line. The minimum DLS-PDU size of 125 byte is assumed (cf. section 4.2). The expected bit error rate of LDACS1 after FEC is  $10^{-5}$ . This is indicated with vertical dotted lines. The required level of continuity is marked by the horizontal dotted line (i.e. 99.9x%). Note that different service classes have differing requirements.

The calculations show clearly that the required continuity cannot be achieved with the current FEC and without ARQ. Not allowing retransmissions the effective frame error rate would have to be decreased by three orders of magnitude.

The usage of strong error correcting codes in LDACS1 cannot be avoided in any case due to the unfavourable interference conditions of the radio channel. Using the default coding and modulation a bit error rate of  $10^{-5}$  can be achieved using FEC. However, in this case the coding rate is approximately  $\frac{1}{2}$  i.e. for each bit of information two bits have to be

transmitted on the channel. Lower frame error rates would come at the cost of over-proportionally increasing the coding overhead even more, thus any remaining errors have to be recovered by retransmissions i.e. LDACS1 has to apply HARQ<sup>13</sup>.

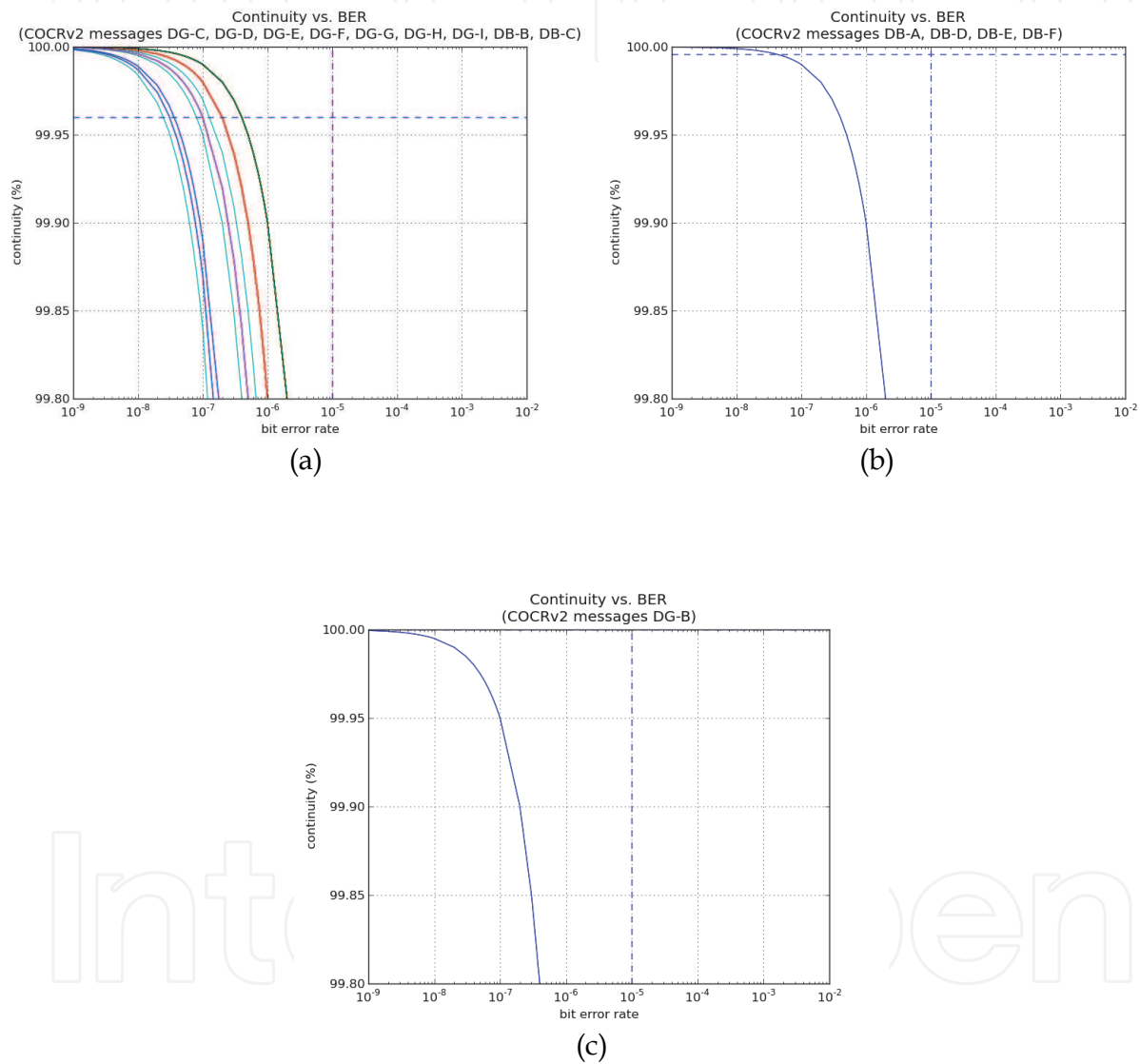

Fig. 8. Continuity of COCRv2 messages (no ARQ).

<sup>13</sup>The precise term is Type 1 HARQ. The more advanced Type 2 HARQ (with progressively increasing FEC) is not used in LDACS1.



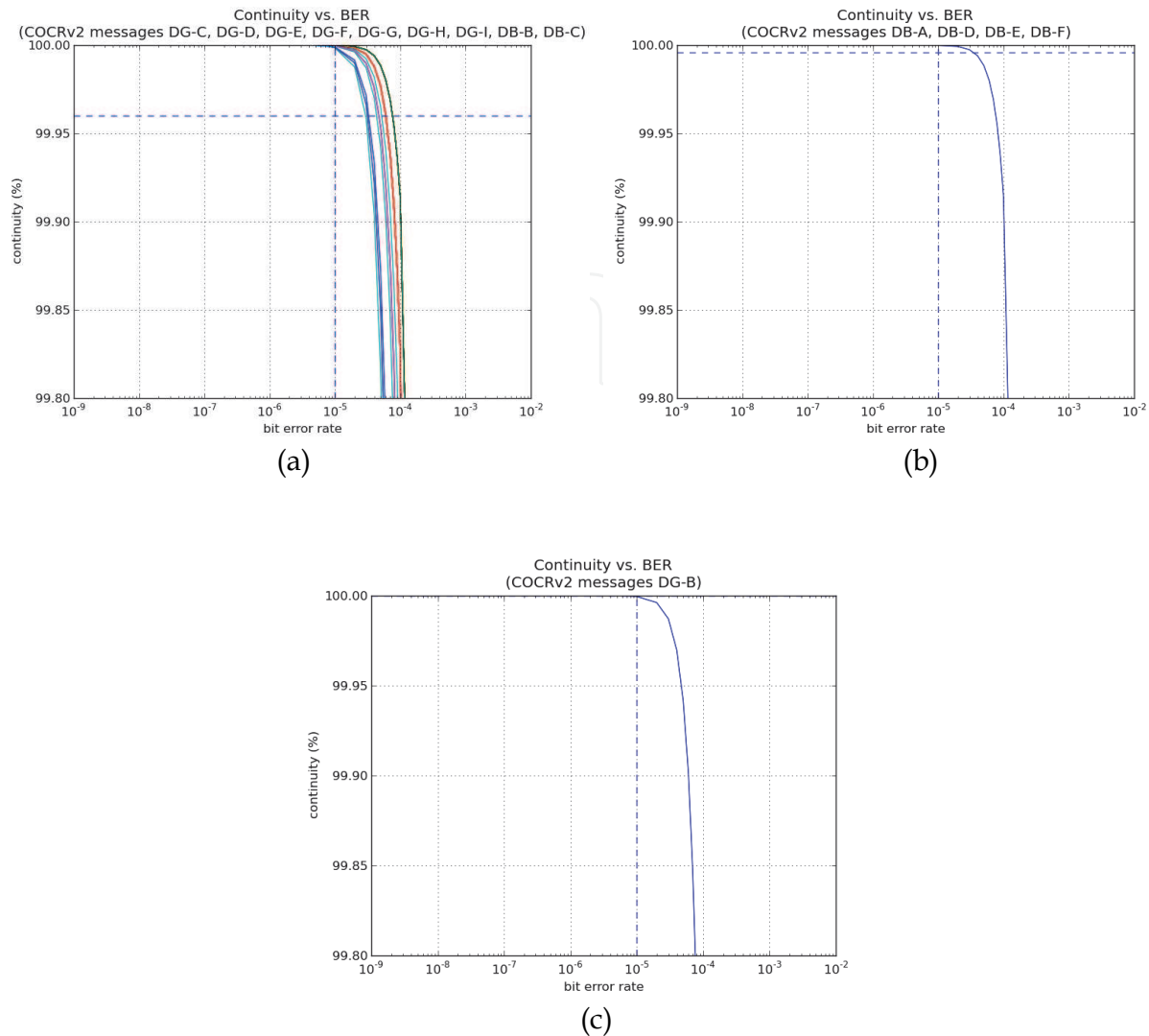

Fig. 9. Continuity of COCRv2 messages (ARQ up to 2 retransmissions).

Fig. 9 displays the levels of continuity that can be achieved by allowing up to two ARQ retransmissions ( $R=2$ ). The minimum DLS-PDU size of 125 byte is assumed i.e. as the packet error rate increases with larger DLS-PDU sizes the identified value for  $R$  is a lower bound for the required number of retransmissions. The results indicate that the requirements can now be fulfilled for the expected frame error rate of LDACS1 and for all service classes in this case.

An additional benefit of ARQ is that non-duplication of messages is enforced by the protocol. Thus the main focus of the DLS ARQ design was on the efficient recovery from packet losses through retransmissions. The efficiency of the retransmission mechanism is determined by the ability to retransmit lost fragments of a message such that the quality of service requirements of the message are not violated i.e. the protocol had to be designed to provide quick retransmissions in order to be effective.

### 3.5.2 Data link service timer management

DLS timer management was identified as crucial for the overall protocol performance in the LDACS1 evaluation. It was therefore proposed to couple the DLS timer management to the

MAC time framing to achieve near optimal performance. Thus, the LDACS1 ARQ protocol operates in fixed timing relations to the medium access sub-layer.

Depending on the physical layer implementation (i.e. decoding latency) there are two optimal acknowledgement opportunities for a DLS-PDU transmitted in a Data slot: The first opportunity is to acknowledge the DLS-PDU in the control channel slot of the same multi-frame. The second opportunity is to use the first control channel slot after the current multi-frame (e.g. if the transmission of the DLS-PDU and the control channel slot overlap).

The retransmission timer defines the maximum number of missed acknowledgement opportunities, before a retransmission is triggered. According to the last paragraph, the DLS retransmission timer should time out after not more than two missed acknowledgement opportunities.

Fig. 10 illustrates the DLS retransmission timer on the reverse link. After the aircraft-station has sent a DLS-PDU in the RL Data slot there are two possible acknowledgment opportunities on the forward link. The DLS retransmission timer is set to the end of the second acknowledgement opportunity.

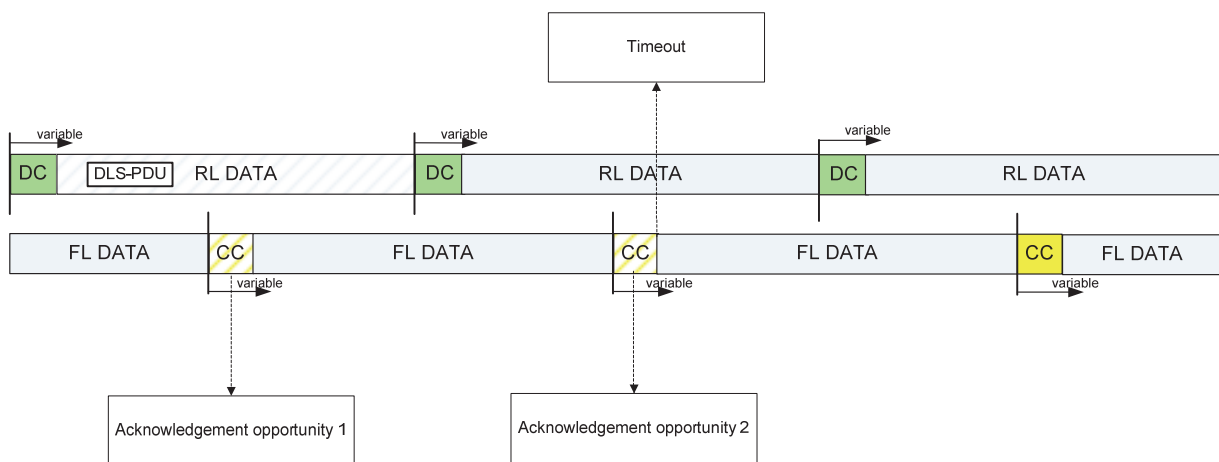

Fig. 10. LDACS1 RL DLS retransmission timer.

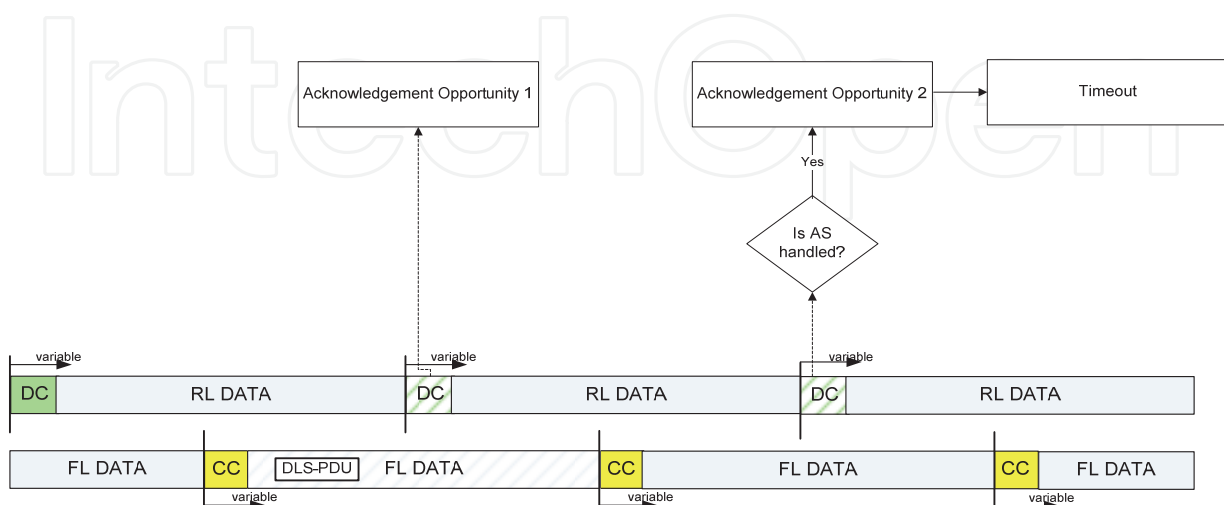

Fig. 11. LDACS1 FL DLS retransmission timer.

Fig. 11 displays the same concept for the forward link DLS retransmission timer. There are two acknowledgement opportunities on the reverse link after the DLS Data PDU is sent. The first opportunity could be in the DC slot during the FL Data slot of the transmission. The second acknowledgement opportunity is the next appearance of the receiving aircraft-station's DCCH. According to the number of registered aircraft-stations not every aircraft-station is able to send its DCCH in each multi-frame. The timeout is therefore set to the end of the next DC slot where the aircraft-stations DCCH is transmitted.

Note that the first DC slot can always be counted as an acknowledgement opportunity, as the acknowledgement has to be sent in the next DC slot in any case.

### 3.5.3 Link management entity resource allocation

Channel resources for transmission have to be requested by the DLS from the radio resource management in the ground-station LME. The ground-station DLS makes these requests locally using an internal interface, while the aircraft-station DLS has to make its request over the dedicated control channel DCCH. The radio resource management stores these requests to calculate an appropriate resource allocation. Note that the aircraft-station DLS makes separate resource requests for each class of service. Requests are encoded in a single (variable length) control message.

The resource allocation for the next forward link and reverse link data slots is then calculated after the end of the DC slot when the LME has collected the resource requests of all aircraft-stations serviced in this multi-frame. The gap between the DC slot and the CC slot is used to calculate the assignment and to prepare it for transmission in the CC (i.e. generate FL and RL allocation control messages; cf. Fig. 6).

The allocation algorithm has not been defined in the LDACS1 specification, but is left open to the implementer. The simulations presented in this chapter use a comparatively simple prioritized round-robin resource allocation algorithm. This algorithm respects the priorities of the different classes of service and is fair between requests of the same priority.

The resource allocation of the forward link and reverse link are calculated independently, but following the same approach: In the first step the resource requests are sorted according to their priority and class of service: High priorities before low priorities, and acknowledged transmissions before unacknowledged transmissions. In the second step resource allocations are granted in round-robin within each class of service. If the class has been completely serviced the next class is served. The algorithm assigns the largest possible allocation limited by the size of the data slot.

For the reverse link allocations an additional restriction is introduced to reduce the duty cycle and the interference generated by the system. The maximum size of the resource allocation is limited to 16 OFDM tiles. This is equivalent to a maximum reverse link sending time of 5.76 milliseconds. Note that this restriction has no formal motivation. It was assumed as a working hypothesis in the physical layer development. Its size can, however, be configured.

Note that only the sum of all resource allocations is transmitted to the user as it can be locally distributed by the DLS quality of service function according to the transmitted requests.

## 4. Design validation

The design validation of the LDACS1 protocol was carried out in a computer simulation implementing the medium access sub-layer and the logical link control sub-layer. This section presents the discussion of selected simulation results according to the evaluation criteria stated in Section 2.1 and formalized in section 4.3.

### 4.1 Simulation scenarios

The design validation was performed on the basis of the data traffic profile (also called “mobile communication operational concept”) defined in the COCRv2 report (EUROCONTROL & FAA, 2007b) and the air traffic volumes defined in the companion document to the COCRv2 (EUROCONTROL & FAA, 2007c). Both documents were produced in AP17 technical task 2.

The COCRv2 mobile communications operational concept is very detailed and is described on the basis of a set of anticipated (i.e. hypothetical) data link services. These services are divided into three categories: ATC, AOC, and Network Management Services (NET). Each of these services is described in great detail: The events triggering the generation of a data packet, size and quantity of the packet, expected reaction of the peer entity (i.e. responses or acknowledgements), and the expected class of service.

It was recognized by the authors of the COCRv2 report that this elaborate model is non-trivial to implement, in particular, as it requires a detailed air traffic model. Therefore the COCRv2 report was augmented with the companion document (EUROCONTROL & FAA, 2007c) containing a set of simplified evaluation scenarios. These simplified scenarios were designed such as to ensure that all COCRv2 services can be supported if the simplified requirements are fulfilled i.e. they are worst case scenarios.

These evaluation scenarios are “simplified” in the sense that the scenarios of the companion document are easier implemented by the evaluator. The simplified scenarios were also created using the COCRv2 data link service descriptions. However, they were already based on synthetic air traffic situations (i.e. artificial air traffic provided by the authors of the COCRv2 report) referred to as “air traffic volumes”.

An excerpt of the relevant air traffic volumes is cited in Table 2. The “APT Surface” traffic volume has been left aside in this section as this communication domain is covered by the dedicated IEEE 802.16e based airport surface data link. The “ENR Super Large” traffic volume covers an area larger than the area that could be covered using the theoretical maximum range of L-DACS1, which is 200 nautical miles. It is therefore left aside, too.

Except for the APT Zone traffic volume, which is cylindrical, all traffic volumes are cuboids of different sizes. The TMA and ENR traffic volumes have constant heights of 19,500 feet (approximately 6,000 meters) and 20,500 feet (approximately 6,300 meters), respectively. Each traffic volume has a Peak Instantaneous Aircraft Count value (PIAC) reporting the maximum number of aircraft to be expected within this volume at the same time.

In addition to the introduction of synthetic air traffic, data traffic is no longer presented at the packet level, but aggregated into average user data rates (i.e. offered load) as displayed in Table 3. The user data rates are split into four scenarios: Either ATS traffic alone or ATS and AOC traffic combined, with or without the very demanding A-EXEC<sup>14</sup> service. The most challenging scenario is the ATS+AOC scenario with A-EXEC service.

---

<sup>14</sup>The A-EXEC service provides an automated safety net to capture situations where encounter-specific separation is being used and a non-conformance FLIPINT event occurs with minimal time remaining to

Ref.	Type	Dimensions	Height Range	Number of aircraft (PIAC)
TV 1.1	APT Zone	Cylinder, 10 NM <sup>15</sup> diameter	0 – FL50 <sup>16</sup>	26
TV 1.2	APT Surface	Cylinder, 5 NM diameter	0	264 <sup>17</sup>
TV 2.1	TMA Small	Cuboid, 49 x 49 NM	FL50 – FL245	44
TV 2.2	TMA Large	Cuboid, 75.0 x 75.0 NM	FL50 – FL245	53
TV 3.1	ENR Small	Cuboid, 55 x 55 NM	FL245 – FL450	45
TV 3.2	ENR Medium	Cuboid, 100.0 x 100.0 NM	FL245 – FL450	62
TV 3.3	ENR Large	Cuboid, 200.0 x 200.0 NM	FL245 – FL450	204
TV 3.4	ENR Super Large	Cuboid, 400.0 x 400.0 NM	FL245 – FL450	522

Table 2. Traffic volumes. Cited from (EUROCONTROL & FAA, 2007c).

At the start of each simulation scenario the air traffic volume is populated with aircraft. The scenarios do not require the simulation of cell entry and cell exit therefore it is assumed that the number of aircraft is constant at the PIAC during the complete simulation time. The position of the aircraft within the traffic volume is not simulated as the physical layer simulations covered the influence of the aircraft's position already with worst case assumptions.

#### 4.2 Simulation parameters

The simulation implemented the LDACS1 protocol according to (Sajatovic et al., 2011), and the descriptions given in the previous sections.

The evaluation scenarios were simulated using a higher layer packet size of 125 Byte<sup>18</sup> with a single class of service<sup>19</sup>. Each higher layer packet is extended by a 3 Byte SNDCP header and at least one 7 Byte DLS-PDU header (assuming minimal fragmentation). Together these headers add 10 Bytes of overhead to each higher layer packet which is equivalent to 8%

---

resolve the conflict. [...] When non-conformance occurs, triggering an imminent loss of separation, the ground automation system generates and sends a resolution to the aircraft for automatic execution without the Flight Crew or Controller in the loop." (EUROCONTROL & FAA, 2007b)

<sup>15</sup>Nautical miles.

<sup>16</sup>Flight Level FL expresses the aircraft altitude (above mean sea level) in steps of 100 ft (e.g. FL50 corresponds to an aircraft altitude of 5000 ft above mean sea level). Note that the abbreviation FL is also used for the Forward Link FL (i.e. ground-to-air) transmission direction depending on the context.

<sup>17</sup>The APT Surface traffic volume contains all aircraft on the ground. The other traffic volumes contain only airborne aircraft.

<sup>18</sup>Note that this is the near the most common packet size defined in COCRv2 and that the SNDCP may perform additional fragmentation and reassembly if necessary.

<sup>19</sup>Simulation results for larger packet sizes and several service classes can be found in (Gräupl et al., 2009).

overhead. The simulation duration was set to 500 seconds plus 5 additional seconds of follow up time. Each scenario was simulated ten times with different random seeds.

Scenario	PIAC	Average User Data Rate (kbit/s)							
		ATS Only, with A-EXEC		ATS + AOC, with A-EXEC		ATS Only, without A-EXEC		ATS + AOC, without A-EXEC	
		FL <sup>20</sup>	RL	FL	RL	FL	RL	FL	RL
APT Zone	26	-	-	-	-	3	10	3	15
APT Surface	264	-	-	-	-	30	30	150	30
TMA Small	44	30	30	30	30	30	30	30	30
TMA Large	53	30	30	30	30	30	30	30	30
ENR Small	45	30	30	150	30	30	30	80	30
ENR Medium	62	30	30	150	30	30	30	100	30
ENR Large	204	30	40	300	40	30	40	200	40
ENR Super Large	522	40	50	500	50	40	50	500	50

Table 3. Validation scenarios.

All simulation scenarios used the same medium access sub-layer and logical link control sub-layer settings. If not stated otherwise the DC slot size was set to 52 tiles. The maximum reverse link allocation size was set to 16 PHY-SDUs per aircraft-station and multi-frame. This is equivalent to a maximum reverse link sending duration of 5.76 milliseconds per multi-frame not taking the DC slot into account. The DLS ARQ window size was set to 4 DLS-SDUs with up to 4 DLS-PDUs per transmission buffer. The maximum DLS-PDU size was set equal to the DLS-SDU size (i.e. no fragmentation).

The physical layer bit error rate was set to 10<sup>-5</sup> after FEC. Bit errors were simulated for all logical channels. With the exception of the “ENR Large ATS+AOC with A-EXEC” scenario the default coding and modulation was used. This scenario uses ACM type 2 (QPSK, coding rate 2/3) coding. The “ENR Super Large ATS+AOC with A-EXEC” and “ENR Super Large ATS+AOC with-out A-EXEC” are actually out of the scope of LDACS1, but were included into the simulations with ACM type 4 coding and modulation (16QAM, coding rate 1/2). Results using non-default ACM settings are indicated in *italic* font.

### 4.3 Validation parameters

The LDACS1 design goals were validated according to the evaluation scenarios defined above and the quality of service requirements defined in Section 4.6 of (EUROCONTROL & FAA, 2007c). The quality of service requirements are defined in terms of continuity and the 95% percentile of the one-way transmission latency (TT<sub>95-1 way</sub>).

All values of interest are estimated by the mean of ten measurements. The measurements considered in the presented results are defined as follows:

**Latency:** The one-way latency of a data packet is calculated as the time between the creation of the packet and its successful reception. This value is validated against the “TT<sub>95-1 way</sub>” requirement.

<sup>20</sup>In this table FL and RL denote Forward Link (ground-to-air) and Reverse Link (air-to-ground) directions.

**Continuity:** The percentage of packets that is not lost, duplicated or expired. This value is validated against the “Continuity” requirement in Table 4.

Scenario	Without A-EXEC		with A-EXEC	
	TT95-1 way (s)	Continuity (%)	TT95-1 way (s)	Continuity (%)
APT	1.4	99.96	-	99.999992
TMA	1.4	99.96	0.74	99.999992
ENR	1.4	99.96	0.74	99.999992
ORP	5.9	99.96	-	99.999992
AOA	1.4	99.96	-	99.999992

Table 4. Quality of service requirements. Cited from (EUROCONTROL & FAA, 2007c).

#### 4.4 Results

The design goal for responsiveness is fulfilled if the 95%-percentile values of the LDACS1 one-way latency satisfy the requirements of Table 4. The results presented in Table 5 indicate that LDACS1 fulfils all these requirements in the presented validation scenarios. Note that the “ENR Large ATS+AOC with A-EXEC” scenario uses ACM type 2. “ENR Super Large ATS+AOC with A-EXEC” and “ENR Super Large ATS+AOC with-out A-EXEC” use ACM type 4. The PIAC in these scenarios was changed from 522 aircraft to 512 aircraft as this is the maximum supported by LDACS1 in a single radio cell.

The latency requirements of the A-EXEC service (740 milliseconds) is fulfilled in all cases. This indicates that the DC slot size (and hence the dedicated control channel capacity) may be reduced. Table 6 displays the 95% percentile results for reduced dedicated control channel capacity. The size of the DC slot was constrained to the minimum number of tiles according to Table 1.

The results show that the 95% percentile of the one-way latency changes indeed as predicted. With the exception of the ENR Medium no-A-EXEC scenario (DC is 3 tiles, TT<sub>95-1</sub> way requirement is 1400 milliseconds) all requirements are met with the minimum slot sizes. The failed requirement poses no real problem as the DC slot size can be easily increased above the minimum value. It should be noted that the forward link latency also increases when the DC slot is smaller. This is caused by the ARQ transmission window which can only be shifted at the reception of a new acknowledgement in the dedicated control channel.

The results indicate that the theoretical analysis of section 3.4.2 provides a good starting point for optimization but tends to underestimate the required DC slot size in realistic scenarios. However, the requirements are only missed by a small margin (72 ms).

Scenario	PIAC	95% percentile of latency (TT95-1 way)							
		ATS Only, with A-EXEC		ATS+AOC, with A-EXEC		ATS Only, without A-EXEC		ATS+AOC, without A-EXEC	
		FL	RL	FL	RL	FL	RL	FL	RL
APT Zone	26	-	-	-	-	125	412	126	412
APT Surface	264	-	-	-	-	134	178	134	179
TMA Small	44	128	180	128	180	128	180	128	180
TMA Large	53	125	187	125	187	125	187	125	187
ENR Small	45	127	180	128	180	127	180	127	180
ENR Medium	62	125	227	126	227	125	227	125	227
ENR Large	204	125	350	161	349	125	350	129	350
ENR Super Large	512	125	695	212	693	125	695	212	693

Table 5. LDACS1 responsiveness (TT95-1 way); DC size 52.

Scenario	PIAC	95% percentile of latency (TT95-1 way)							
		ATS Only, with A-EXEC		ATS+AOC, with A-EXEC		ATS Only, without A-EXEC		ATS+AOC, without A-EXEC	
		FL	RL	FL	RL	FL	RL	FL	RL
APT Zone	26	-	-	-	-	141	868	145	868
APT Surface	264	-	-	-	-	139	1296	141	1296
TMA Small	44	143	639	143	639	143	988	143	988
TMA Large	53					144	1146	144	1146
ENR Small	45	142	646	430	635	144	994	579	996
ENR Medium	62	143	724	334	719	144	1321	1472	1323
ENR Large	204	137	706	187	708	141	1298	218	1307
ENR Super Large	512	126	709	207	711	136	1350	272	1350

Table 6. LDACS1 responsiveness (TT95-1 way) ; minimum DC size.



Scenario	PIAC	Continuity in %							
		ATS Only, with A-EXEC		ATS+AOC, with A-EXEC		ATS Only, without A-EXEC		ATS+AOC, without A-EXEC	
		FL	RL	FL	RL	FL	RL	FL	RL
APT Zone	26	-	-	-	-	100	100	100	100
APT Surface	264	-	-	-	-	100	100	100	100
TMA Small	44	100	100	100	100	100	100	100	100
TMA Large	53	100	100	100	100	100	100	100	100
ENR Small	45	100	100	100	100	100	100	100	100
ENR Medium	62	100	100	100	100	100	100	100	100
ENR Large	204	100	100	100	100	100	100	100	100
ENR Super Large	512	100	100	100	100	100	100	100	100

Table 7. LDACS1 continuity ; DC size 52.

#### 4.4.2 Reliability

The evaluation of the LDACS1 continuity in the defined simulation scenarios shows that LDACS1 can fulfil the continuity requirements of (EUROCONTROL & FAA, 2007c) in all cases.

#### 4.4.3 Scalability

The fact that LDACS1 fulfils the COCRv2 requirements in all investigated cases indicates that the system provides the required scalability.

### 5. Conclusion

The objective of the LDACS1 development was to create a first protocol specification enabling prototyping activities. It was not the goal of this development to create a final product and it is expected that further refinements of the protocol will originate from prototyping. However, the analysis, design, and validation of LDACS1 produced a framework of protocols backed by formal and simulation based analysis. The goal was to develop a protocol design providing the quality of service required for future ATM operations.

The LDACS1 research produced a deterministic medium access approach built on the lessons learnt from its predecessor protocols. This approach ensures that the medium access latency is only coupled to the number of aircraft-stations served by the ground-station. The medium access performance degrades only linearly with the number of users and not exponentially as in the case of random access. In the LDACS1 protocol design the resource allocation between different users is performed centralized by the ground-station while the

resource distribution between packets of different priorities is performed locally by each user. The effect of this approach is that the medium access sub-layer supports prioritized channel access.

The analysis of the requirements towards the overall communication system performance produced the justification for the use of ARQ in the LDACS1 logical link control sub-layer. Coupling the DLS timer management to the MAC sub-layer time framing has the effect to produce near to optimal timer management. LDACS1 can thus be considered a mature technology proposal offering a solid baseline for the definition of the future terrestrial radio system envisaged in AP17.

LDACS1 has now entered a new phase within the protocol engineering process going from the development phase to the prototyping phase. The initial specification can now be considered complete and evaluated. The next steps will be determined by the further optimization of the protocol and the evaluation of the prototype within the context of the Single European Sky ATM Research Programme (SESAR).

## 6. References

- Brandes, S.; Epple, U.; Gligorevic, S.; Schnell, M.; Haindl, B. & Sajatovic, M. (2009). Physical Layer Specification of the L-band Digital Aeronautical Communications System (LDACS1), Proceedings ICNS'09, ISBN 978-1-4244-4733-6, Washington DC, May 2009.
- Budinger, J. & Hall, E. (2011). Aeronautical Mobile Airport Communications System (AeroMACS), In: *Future Aeronautical Communications*, Plass, S., InTech, ISBN 979-953-307-443-5
- Commission of the European Communities. (2001). European transport policy for 2010: time to decide, Office for official publications of the European Communities, ISBN 92-894-0341-1, Brussels
- Eleventh Air Navigation Conference. (2003). Report of Committee B to the Conference on Agenda Item 7, Available from: [http://www.icao.int/icao/en/anb/meetings/anconf11/documentation/anconf11\\_wp202\\_en.pdf](http://www.icao.int/icao/en/anb/meetings/anconf11/documentation/anconf11_wp202_en.pdf)
- EUROCONTROL & FAA. (2007a). Action Plan 17 Future Communications Study - Final Conclusions and Recommendations, Available from: [http://www.eurocontrol.int/communications/gallery/content/public/documents/AP17\\_Final\\_Report\\_v11.pdf](http://www.eurocontrol.int/communications/gallery/content/public/documents/AP17_Final_Report_v11.pdf)
- EUROCONTROL & FAA. (2007b). Communication Operating Concept and Requirements for the Future Radio System, Ver. 2, Available from: <http://www.eurocontrol.int/communications/gallery/content/public/documents/COCR%20V2.0.pdf>
- EUROCONTROL & FAA. (2007c). Evaluation Scenarios, Available from: [http://www.eurocontrol.int/communications/gallery/content/public/documents/FCS\\_Eval\\_Scenarios\\_V10.pdf](http://www.eurocontrol.int/communications/gallery/content/public/documents/FCS_Eval_Scenarios_V10.pdf)
- European Commission. (2011). Single European Sky, Available from: [http://ec.europa.eu/transport/air/single\\_european\\_sky/single\\_european\\_sky\\_en.htm](http://ec.europa.eu/transport/air/single_european_sky/single_european_sky_en.htm)

- Fistas, N. (2009). Future Aeronautical Communication System - FCI, Proceedings of Take Off Conference, Salzburg, April 2009.
- Gräupl, T.; Ehammer, M.; & Rokitansky, C.-H. (2009). LDACS1 Data Link Layer Design and Performance, Proceedings of ICNS'09, ISBN 978-1-4244-4733-6, Washington DC, May 2009.
- Haindl, B.; Rihacek, C.; Sajatovic, M.; Phillips, B.; Budinger, J.; Schnell, M.; Lamiano, D. & Wilson, W. (2009). Improvement of L-DACS1 Design by Combining B-AMC with P34 and WiMAX Technologies, Proceedings of ICNS'09, ISBN 978-1-4244-4733-6, Washington DC, May 2009.
- Helfrick, A. (2007). Principles of Avionics (4th ed.). Airline Avionics, ISBN 978-1885544261, Leesburg, VA
- IATA. (2003). IATA Position on Aeronautical Air Ground Communications Needs, Available from:  
[http://www.icao.int/icao/en/anb/meetings/anconf11/documentation/ANConf11\\_wp054\\_en.pdf](http://www.icao.int/icao/en/anb/meetings/anconf11/documentation/ANConf11_wp054_en.pdf)
- Kamali, B. (2010). An Overview of VHF Civil Radio Network and the Resolution of Spectrum Depletion, Proceedings of ICNS'10, ISBN 2155-4943, Washington DC, May 2010.
- Sajatovic, M.; Haindl, B.; Epple, U. & Gräupl, T. (2011). Updated LDACS1 System Specification. SESAR P15.2.4 EWA04-1 task T2 Deliverable D1.
- Rokitansky, C.-H.; Ehammer, M.; Gräupl, T.; Schnell, M.; Brandes, S.; Gligorevic, S.; Rihacek, C. & Sajatovic, M. (2007). B-AMC a system for future broadband aeronautical multi-carrier communications in the L-band, Proceedings of 26th DASC, ISBN 978-1-4244-1108-5, Dallas TX, Nov. 2007.

IntechOpen



## **Future Aeronautical Communications**

Edited by Dr. Simon Plass

ISBN 978-953-307-625-6

Hard cover, 378 pages

**Publisher** InTech

**Published online** 26, September, 2011

**Published in print edition** September, 2011

There are well-founded concerns that current air transportation systems will not be able to cope with their expected growth. Current processes, procedures and technologies in aeronautical communications do not provide the flexibility needed to meet the growing demands. Aeronautical communications is seen as a major bottleneck stressing capacity limits in air transportation. Ongoing research projects are developing the fundamental methods, concepts and technologies for future aeronautical communications that are required to enable higher capacities in air transportation. The aim of this book is to edit the ensemble of newest contributions and research results in the field of future aeronautical communications. The book gives the readers the opportunity to deepen and broaden their knowledge of this field. Today's and tomorrow's problems / methods in the field of aeronautical communications are treated: current trends are identified; IPv6 aeronautical network aspect are covered; challenges for the satellite component are illustrated; AeroMACS and LDACS as future data links are investigated and visions for aeronautical communications are formulated.

### **How to reference**

In order to correctly reference this scholarly work, feel free to copy and paste the following:

Thomas Gräupl and Max Ehammer (2011). The LDACS1 Link Layer Design, Future Aeronautical Communications, Dr. Simon Plass (Ed.), ISBN: 978-953-307-625-6, InTech, Available from: <http://www.intechopen.com/books/future-aeronautical-communications/the-ldacs1-link-layer-design>

**INTECH**  
open science | open minds

#### **InTech Europe**

University Campus STeP Ri  
Slavka Krautzeka 83/A  
51000 Rijeka, Croatia  
Phone: +385 (51) 770 447  
Fax: +385 (51) 686 166  
[www.intechopen.com](http://www.intechopen.com)

#### **InTech China**

Unit 405, Office Block, Hotel Equatorial Shanghai  
No.65, Yan An Road (West), Shanghai, 200040, China  
中国上海市延安西路65号上海国际贵都大饭店办公楼405单元  
Phone: +86-21-62489820  
Fax: +86-21-62489821

© 2011 The Author(s). Licensee IntechOpen. This chapter is distributed under the terms of the [Creative Commons Attribution-NonCommercial-ShareAlike-3.0 License](#), which permits use, distribution and reproduction for non-commercial purposes, provided the original is properly cited and derivative works building on this content are distributed under the same license.

IntechOpen

IntechOpen