

We are IntechOpen, the world's leading publisher of Open Access books Built by scientists, for scientists

4,800

Open access books available

122,000

International authors and editors

135M

Downloads

Our authors are among the

154

Countries delivered to

TOP 1%

most cited scientists

12.2%

Contributors from top 500 universities



WEB OF SCIENCE™

Selection of our books indexed in the Book Citation Index
in Web of Science™ Core Collection (BKCI)

Interested in publishing with us?
Contact book.department@intechopen.com

Numbers displayed above are based on latest data collected.
For more information visit www.intechopen.com



Bi-Directional DC - DC Converters for Battery Buffers with Supercapacitor

Jan Leuchter
*University of Defence,
Czech Republic*

1. Introduction

Sources of electrical energy for industry, agriculture or military use are different with respect to the purpose, place, sort of appliance, type of supplied systems. Fixed military facilities, for example, bases and camps are supplied by common electrical network system. Uninterruptible power sources are used to span short network black-outs and to maintain the power quality supplied to computers and other sensitive electronic equipment due to dips, surges and voltage reductions (Kurka & Leuchter, 2008).

In vehicles and aircraft various types of accumulator batteries are used for starting of engines, on-board generators as main source of electrical energy are driven by operating engines. Stable electrical power generating sets are used for power supply in military bases and camps, where the connection to network is not possible. Mobile generating sets are also used for general use to supply various appliances, facilities, systems, for heating, illumination, and other purposes in industry, agriculture or military units. Most of up to date systems are equipped by specialized built-in generating sets. In studies focused on this problem the sources based on the small nuclear generators, sun and wind energy are speculated, but no one from these technologies is suitable from the mobility, safety and operativity of corresponding application point of view. The majority of above mentioned electrical energy sources use some means of energy accumulation (electrical energy buffers or accumulators) to secure the reliable operation under all possible circumstances and conditions. It is considered as self-evident that fuel cells become another mobile power sources and electrical energy buffers (batteries). Fuel cells were marked as one of the new energetic source alternatives for military applications. In the comparison with classical conversion of fuel (where the efficiency reaches 15 to 35%, and with the gas turbine with max. 40%), fuel cells based on the direct conversion of chemical energy to the electric one reach efficiency 50 to 70%, according to the type, power, used chemicals and design. In the combination with semiconductor converters, systems based on the fuel cells become practically the universal source of electric energy (Kurka & Leuchter, 2008).

With the development of new technologies in transportation, vehicles, renewable energy sources, UPS, mobile electrical energy generating sets and in other branches the accumulation of electrical energy, its transformation and transportation represents one common problem. For this purposes various types of electrical energy buffering methods and converters including buffers are used. As will be shown, supercapacitors are well suited to replace classical batteries and conventional capacitors in many applications. Electrical

energy generating sets (EGS) still are and will probably be in near future based mainly on generators driven by combustion engines using fossil fuels. EGS initially developed and produced mainly for military purposes because EGS enable the independence on the common electrical power network. They are used in ground and air transport, in health service and in other military branches. The EGS are quite indispensable in civil defence, crisis management forces, and naturally in security forces. Sophisticated weapon systems, including aircraft and air defence, artillery systems, transport means, logistical structure and training systems based on computer simulation and virtual reality concepts, require also modern and reliable EGS, corresponding to new conditions and requirements. In order to increase efficiency, decrease the fuel consumption and optimize the operational conditions of mobile electrical power generating sets, the VSCF (variable speed-constant frequency) technology is used. Variable output voltage and frequency are transformed to constant values by means of power electronic converters. Due to inconvenient dynamical properties of VSCF based EGS the electrical energy buffers (accumulators) create the essential part of the system securing its reliable operation and can help improve a dynamic behaviour of diesel engine which is limited mainly by fuel injecting. (Kurka & Leuchter, 2008 and 2000) and (Leuchter et al., 2009).

In the following pages we shall propose the energy buffer of EGS with VSCF technology to illustrate the feature, requirements and advantages of systems with energy buffer. EGS with optimum variable speed is really fine example, where power buffer e.g. can improve dynamic behaviour, improve efficiency, and reduce volume.

2. Electrical power buffer

A simplified block diagram of an electrical generator sets (EGS) with variable speed control can be seen in Figure 1, where ω_a represent actual engine speed and ω_o optimum engine speed. As a consequence of varying the engine speed when using the optimum variable speed control, both the output voltage and the output frequency of the generator vary and must be regulated to a constant value as required by the load. Therefore, a power electronic converter is required to regulate the output voltage and frequency. The real drawback of the concept with optimum variable speed is the inferior engine-generator dynamics. In case of sudden power output increase, the engine can not deliver the requested torque and the result is further decrease of the speed and torque of the engine until the undesirable stop. The diesel engine has namely a time constant of few seconds, which is further limited by fuel injection limitation. Therefore at high change of the speed the engine undesirably stops. This problem of the EGS dynamic behaviour can be improved by means of electrical power buffer. The engine-generator dynamics, poses during sudden transients from low-load to high-load conditions, still poses a challenge in this regard. (Leuchter et al., 2010)

The dynamic behavior analyses of 4 kW EGS with 7.5 kW diesel engine can be summarized to the figure 2. Thus, we see that output power of engine depends on engine speed. We now can describe three types of power for every engine speed. The first power can be denoted as P_{opt} , which represents the power provided by engine operating at the optimal angular speed to achieve the minimum fuel consumption. The second P_{Lmax} represents a maximum power that can be obtained for every speed. If the load power is higher then P_{Lmax} then the engine cannot deliver the requested torque and the result is further decrease of the speed and torque of the engine until the undesirable stop. For carrying out the successful speed change, P_{Lmax} must be higher than power required by the load i.e. the condition $P_{L2} < P_{Lmax}$

must be fulfilled. The third curve P_{rez} is the difference between P_{Lmax} and P_{opt} and it indicates the reserve of power of the system operating at optimal angular speed. For example: if the engine operates with an angular speed of $150 \text{ rad}\cdot\text{s}^{-1}$ then the output power of engine is 1900 W and the power margin of engine is as high as 1700 W . If the power increase is higher, then the diesel engine cannot develop enough power required by the load. (Leuchter et al., 2009).

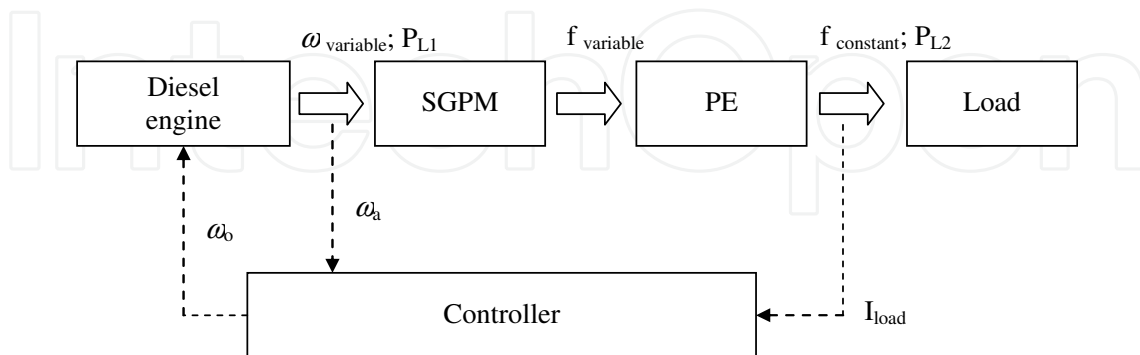

Fig. 1. Block diagram of EGS system with VSCF technology (SGPM-synchronous generator with PM; PE-power electronics)

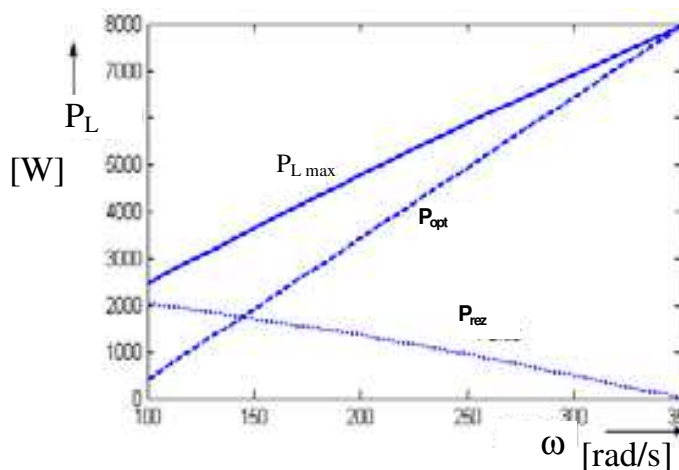

Fig. 2. Identification of the power margin (Diesel engine Hatz 1D40; 7.5 kW)

A power buffer, connected via an electronic converter, can improve the dynamic behaviour of the system with diesel engine by means of injecting stored energy into the dc-link by the dc-dc converter, see Fig. 3. This concept is based on the delivery of peak power from the energy storage to the link capacitor of the dc-dc converter during the low to high speed transition of the diesel engine. The requested energy W is given by the maximal required power P and the average time of the regulation T_R , as given in the following equation

$$W = P \cdot T_R \quad (1)$$

The topology of EGS with battery can achieve some operating advantages. The main advantage of using batteries to cover high power requirements to supply load during short time can be permitted. Or if the batteries are designed to supply half of maximum power while the diesel engine supplies the other half. Such design strategy can reduce the size and cost of the EGS. From it should be apparent that the EGS from figure 3 can bring profitable

results, where is not necessary to note that battery is required by diesel engine for start at any case. Such an approach requires a battery interface by DC bus and bi-directional dc-dc converter. The dc-dc converter makes voltage step up of the low voltage of batteries to the constant dc value e.g. 600 V required by three phase inverter. This chapter has only been able to touch on the most general features of the bi-directional dc-dc converter (blue one) that is shown in figure 3 with battery. Battery and bi-directional converter make power buffer together and our intention here is to highlight to the implementation of converter and battery to the system of EGS and the development in power electronics will be briefed. Also some control method will be discussed regarding the different characteristics of the various EGS systems. (Leuchter et al., 2009).

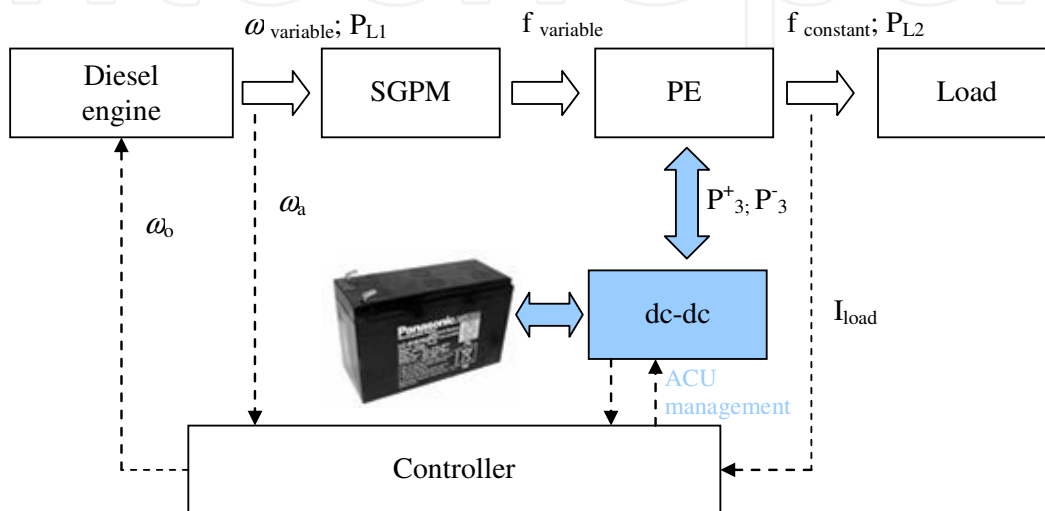

Fig. 3. The bi-directional dc-dc converters

In the following pages main power electronic configurations will be presented and explained with focusing mainly for the dc-to-dc converters, which make interface between battery and loads that is supported by power buffer. Our intention here is to highlights into most important converter topologies, namely bi-directional. Looking ahead to the application of this, we find that these converters operate according quadrants operations.

3. Review of basic electrical multi-quadrant operations

Many types of applications, such as variable speed of diesel engines or wind turbines, use power electronics systems as interface. Power electronics has changed rapidly during the last 20 – 30 years and number applications have been increasing, mainly due to IGBTs (Insulate Gate Bipolar Transistors) devices. Power electronics converters are constructed by power electronics devices, driving, protection and control circuits. A converter, depending on the topology and application, may allow both direction of power flow and can interface between the load and generator sets. There are two different types of converter systems: thyristor converters and pulse modulated (PWM) converters. The high frequency switching of a PWM-converter may produce converters with better power density in comparison with thyristor converters. Due to the high frequencies, the harmonics are relatively easier to be removed what leads to use smaller size filters, especially inductors. On the other hand, the thyristor converters have three important issues in using a power electronic system. These are reliability, efficiency and cost. This part of chapter discusses the modern power

electronics topologies, which play an important role in the area of modern energy source. (Blaabjerg & Chen, 2006)

This leads to some basic principles to show in the following pages. The most important goal of all efforts in developing the product range of power devices and converters is to reach minimum power losses to achieve the maximum efficiency.

Depending on the application, the output to the load may have two main forms: dc and ac. The power converters usually consist of more than one power conversion stage. Converters can be divided into the following categories: ac-to-dc, dc-to-dc, dc-to-ac and ac-to-ac. Our intention here is to highlight and briefly review some of the basic concepts of dc-to-dc conversions. The dc-to-dc converters are widely used in regulated switch-mode dc power sources and dc motor drive applications, where circuits convert fixed dc voltage to variable dc voltage. Such dc converters are very often called as choppers. We can define the multiple - quadrant operation. As shown in Fig. 4, the quadrant I (I-Q) operates with positive voltage and positive current and quadrant II (II-Q) operates with positive voltage and negative current. Quadrant III (III-Q) operates with negative voltage and negative current and quadrant IV (IV-Q) operates with negative voltage and positive current.

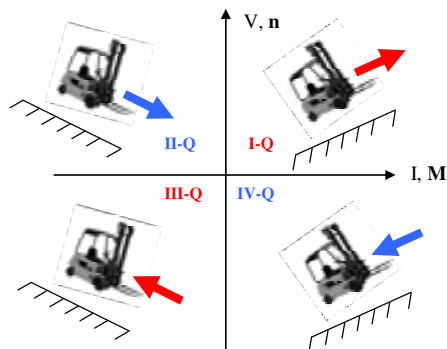

Fig. 4. Four-quadrant operation

We begin our study with a variable speed drive for a DC motor to understand what four-quadrant operation is. We assume that its operation is restricted to I-Q. Machines are seldom DC used as generators (II-Q and IV-Q). However, they operate as a generator while braking, where their speed is being reduced. During the braking operation, the polarity of armature voltage (V_L) does not change, since the direction of the rotation has not changed. If the terminal voltage (V) polarity is also reversed, the direction of the rotation of the motor will reverse. Therefore, a DC motor can operate in either direction and its electromagnetic torque can be reversed for braking, as shown by the four quadrant of the torque/ speed plane in Fig. 4. (Mohan et al., 2002)

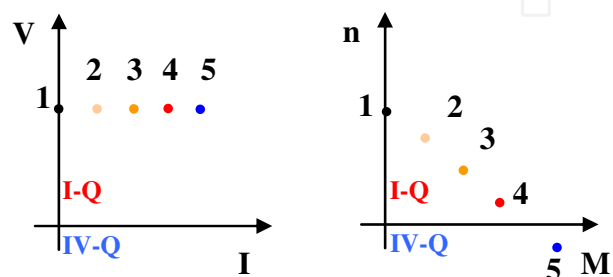

Fig. 5. Operating modes of and DC electric drive in I-Q and IV-Q of the current/ voltage plane of the source and torque/ speed plane of the drive

The field excitation is fixed and the speed is varied by the armature voltage. A pulse converter is connected between the armature and DC source. In addition, the converter processor can be set for any desired motor speed (n) and torque (M). Using the analogy between electric circuits and car behaviour, we can obtain results as follows. The slope of the street has effect on the results in a change of the load torque (M) of DC drive. In the Fig. 5 the change of the slope can be seen, where the point 1 represents no-load and next points make higher slope of the street ($2 < 3 < 4 < 5$). The higher loads, in this case the higher load represents higher slope of the street, produce higher load torque of the drive and their speed is being reduced. The case of point 5 represents a generator mode, where DC drive was reversed for braking, which was achieved by load up of motor mode. Therefore, higher loads produce higher load torque and higher current until the power is possible to produce. If the required power by the load is higher than power produce by source, then DC drive cannot deliver power to go car up and operate in I-Q, see Fig. 4 again. In this case, the direction of the drive is changed and car goes down and I-Q move to IV-Q.

A DC drive can run in forward or reverse running. The forward process when armature voltage (V_L) and current (I_L) are both positive. Using previous analogy with DC drive, we can draw down the next figures with a pulse converter, which is connected between the armature voltage and DC source. The I-Q of converter and DC motor can be seen in Fig. 6a. The output voltage of forward motoring operation (I-Q) is calculated by Eq. (2), where T is the repeating period, V_{IN} is the input voltage, t_{on} is the switch-on time.

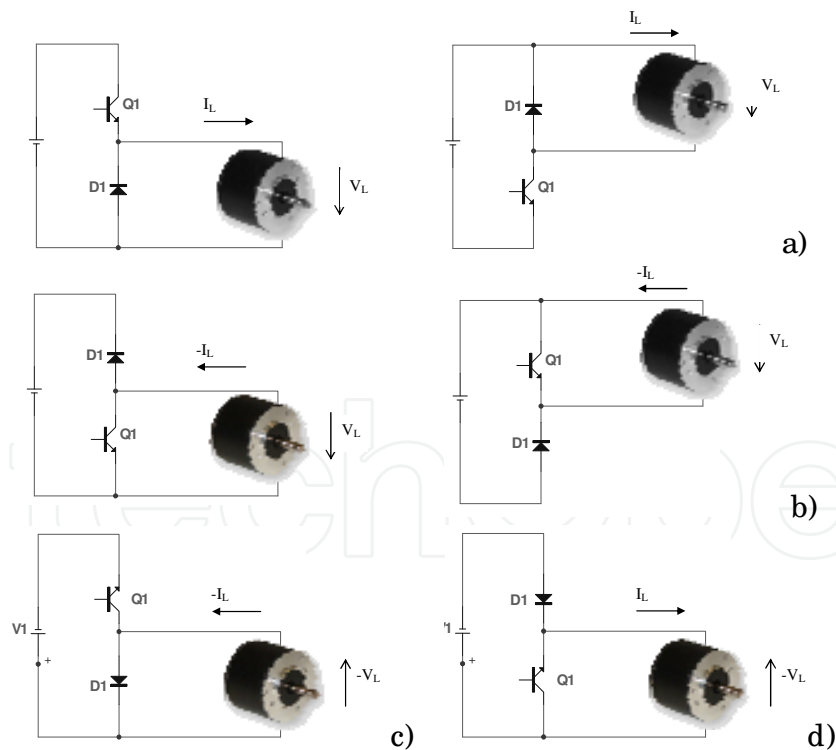

Fig. 6. a) I-Q (motor); b) II-Q (generator); III-Q (motor); IV-Q (generator)

$$V_L = \frac{t_{on}}{T} \cdot V_{IN} , \quad (2)$$

$$V_L = \frac{t_{\text{off}}}{T} \cdot V_{\text{IN}} = \left(1 - \frac{t_{\text{on}}}{T}\right) \cdot V_{\text{IN}}, \quad (3)$$

During the forward braking process its armature voltage is still positive and its armature current is negative. This state can be called as the forward generating operation (II-Q), where the output load voltage are as defined in Eq. (3), where t_{off} is the switch-off time. During the reverse process the DC motor armature voltage and current are both negative (III-Q). The output voltage can be calculated by the formula (2): During the reverse braking process its armature voltage negative and its armature current is positive (IV-Q). The output voltage can be calculated by the formula (3). (Luo & Ye, 2000)

Two-quadrant control is shown in Fig. 7 for I-Q and II-Q. Dual quadrant operation is usually required in the system with two voltage sources.

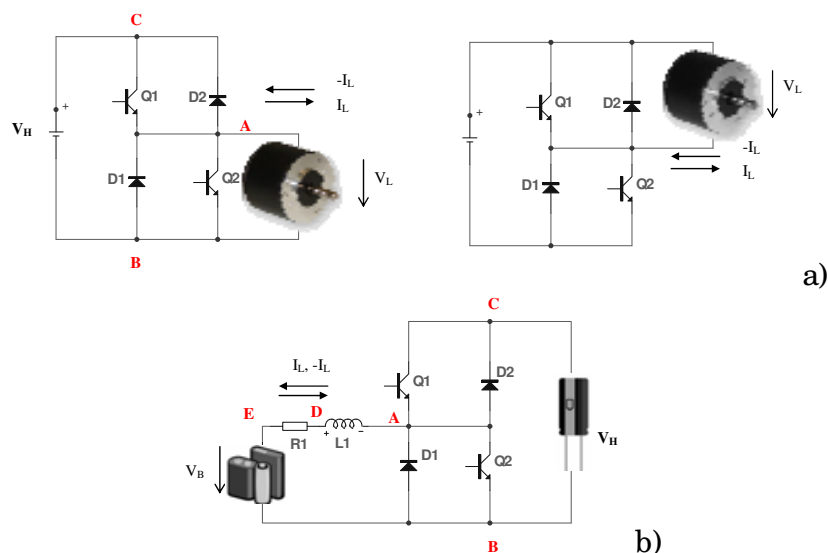

Fig. 7. Two-quadrant converttrs (I-Q, II-Q)

Consider Fig. 7 in which two switches Q1 and Q2 are connected across a dc voltage source V_H . The switched open and close alternately in such a way that when Q1 is switch off, Q2 is switch on and vice versa. The output voltage for a period T oscillates and its average value is given by:

$$V_L = \frac{t_{\text{on}}}{T} \cdot V_H = D \cdot V_H, \quad (4)$$

where D is the duty cycle, V_H is the positive voltage during a period T . (Wildi, 1997). It is apparent that the circuit between point A and B is never open. If current I_L happens to flow into terminal A, it can find its way back to terminal B either via Q2 (if Q2 is closed) or via Q1 (if Q2 is open). Because one of the switches is always closed and it is evident that current I_L can always circulate, which is important feature of this converter. It can be called a two-quadrant converter because the current I_L can flow in either direction, but the polarity of the dc voltage is fixed, where voltage between points A-B (V_{AB}) is always positive.

In point of fact, from this is evident that concept of two-quadrant converter is a variant, which can be used for our application of bi-directional power delivering between battery and dc-dc line. Suppose we want to transfer dc power from terminal A-B to a load such as a

battery, whose dc voltage between E-B (V_{EB}) has value V_B , which is constant while V_{AB} is fluctuating. Despite this we need to apply the buffer between both sides. We could use a resistor R_1 , but the efficiency of converter is reduce or inductance L_1 , as shown in Fig. 8. The inductor L_1 is an ideal component. During I-Q operation, Q1 and D2 works, and Q2 and D1 are idle. Vice versa, during II-Q operation, Q2 and D1 work, and Q1 and D2 are idle. Consequently, the both voltage (V_B and V_H) can be fixed by duty cycle D and relation between the two voltage sources can be calculated by the formula:

$$V_B = D \cdot V_H \dots \text{I-Q}; \quad V_B = (1-D) \cdot V_H \dots \text{II-Q}. \quad (5)$$

If V_B is exactly equal to V_{AB} , no dc current will flow and no dc power exchange. Whereas if is V_B is less than V_{AB} , a dc current I_L will flow from terminal A into terminal E and average value is given by:

$$I_L = \frac{(V_{AB} - V_{EB})}{R_1}. \quad (6)$$

This dc power can only come from the higher voltage source V_H . In this mode, if V_{EB} is less then V_L , the converter works like step-down (buck), which will be discussed in the below in details. (Wildi, 1997)

On the other hand, if V_B is greater than V_{AB} , a dc current I_L will flow out of terminal E and into terminal A, where I_L is also given by (6). Power now flows from the low-voltage battery side V_B to the higher voltage side V_H . In this mode, with V_B greater than V_L , the converter operates like a step-up (boost) converter. Therefore, system of converter from Fig. 7b is able to transfer dc power in both directions by means of changing of current flow and again, such two-quadrant converter operates either in I-Q or II-Q. The detail of system operation can be seen in Fig. 8.

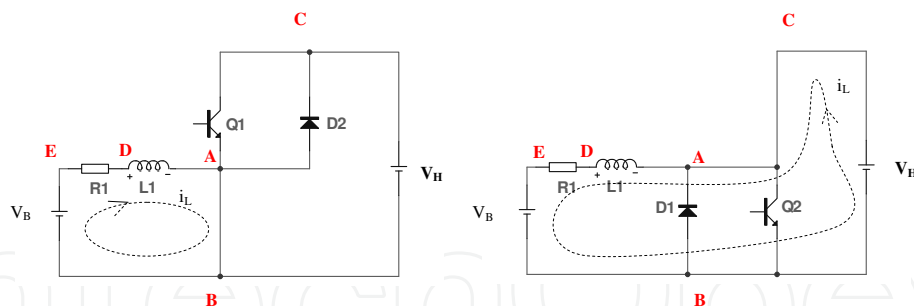

Fig. 8. Two-quadrant dc-to-dc converter (principle of operation of I-Q and II-Q)

If the switch Q2 is closed, the current i_L is given by the voltage V_{DB} and by resistor R_1 as:

$$i_L = \frac{(V_B - V_{DB})}{R_1} \quad (7)$$

$$V_{DB} = V_H - V_B - (R_1 \cdot i_L). \quad (8)$$

And inductor accumulates volt-second during time, when Q2 is closed, and then the voltage across the inductor is given by (8). Terminal voltage V_{DA} is negative and therefore the current i_c is decreasing. The volt-seconds discharging during the time of the switch Q1 is

closed together with previous volt-second during time (when Q2 is closed) gives the current change (peak-to peak ripple). The two-quadrant converter is the basic building block for most switch bi-directional application. (Wildi, 1997)

The multi-quadrant converter for the III-Q and IV-Q operation is shown in Fig. 9a. Both voltage polarities are defined in the figure. Suppose that the $V_H > V_B$ and L is ideal inductor, than III-Q operation, Q1 and D2 work, and Q1 and D2 are idle. The relation between the two voltage sources can be calculated by:

$$V_B = D \cdot V_H \quad \dots \quad \text{III-Q}; \quad V_B = (1-D) \cdot V_H \quad \dots \quad \text{IV-Q} . \quad (9)$$

The next two-quadrant converter can be seen in Fig. 9b, which operates in I-Q and IV-Q.

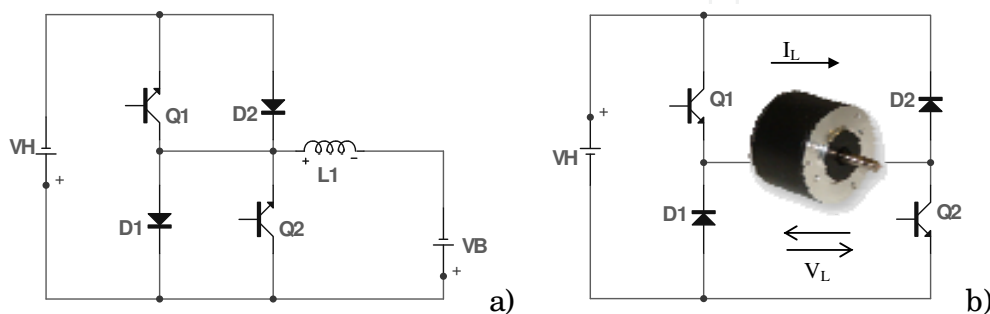

Fig. 9a,b. Two-quadrant dc-to-dc converter a) III-Q and IV-Q) b) I-Q and IV-Q

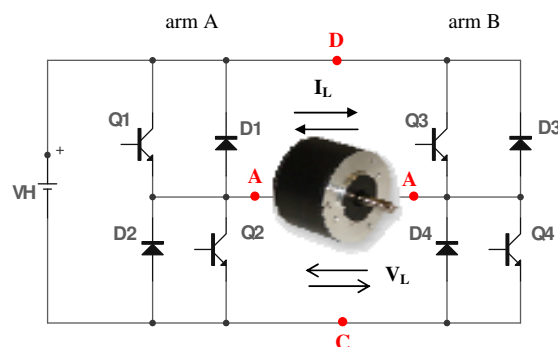

Fig. 9c. Four-quadrant dc-to-dc converter (I-Q, II-Q, III-Q, IV-Q).

As shown in Fig. 4 and 5, the load of these converters is often variable, and therefore it will fluctuate due to changes in the voltage polarities of the load. Switch-mode converters are used to convert the unregulated dc (or ac) input into a controlled dc output at a voltage level. Looking ahead to the application of these converters, we find that these converters are very often used in switch-mode dc power supplies and uninterruptible power sources, energy conversion, transportation, traction control of electrical vehicles, and battery charges. The four-quadrant is shown in Fig. 9c. The input voltage is positive; output voltage can be either positive or negative. The output voltage is given by (10). Anyway, the fourth-quadrant converter consists of two identical two-quadrant converters. Switches Q1 and Q2 in converter (arm A) open and close alternately, as do switches Q3 and Q4 in converter arm B with the same frequency as switches in arm A. The switching sequences are such that Q1 and Q4 open and close simultaneously; similarly, Q2 and Q3 also open and close simultaneously. Consequently, if the duty cycle for Q1 is D, it will also be D for Q4 and then duty cycle for Q2 and Q3 is (1-D). (Wildi, 1997), (Luo & Ye, 2000)

$$\begin{aligned} V_L &= D \cdot V_H \quad \dots I - Q; & V_L &= (1 - D) \cdot V_H \quad \dots II - Q \\ V_L &= -D \cdot V_H \quad \dots III - Q; & V_L &= -(1 - D) \cdot V_H \quad \dots IV - Q \end{aligned} \quad (10)$$

The dc voltage between terminals A and C (V_{AC}) is given by (11) and the dc voltage between terminals B and C (V_{BC}) is given by (12). The dc voltage V_L , which is terminal voltage between A and B is difference between V_{AC} and V_{BC} is given by (13).

$$V_A = D \cdot V_H \quad (11)$$

$$V_B = (1 - D) \cdot V_H \quad (12)$$

$$V_L = V_A - V_B = D \cdot V_H - (1 - D) \cdot V_H = V_H \cdot (2 \cdot D - 1) \quad (13)$$

From (13) we can obtain that the dc voltage is zero when $D=0.5$, the voltage changes linearly with D , becoming $+V_H$ when $D=1$ and $-V_H$ when $D=0$. The polarity of the output voltage can be either positive or negative. Moreover, the dc current flow can be also either from A to B or from B to A. Therefore, the voltage V_L between the output terminals A and B oscillates between $+V_H$ and $-V_H$. Therefore we can deliver power from V_H to V_L , or vice versa, by simply adjusting the duty cycle D .

In the following pages we shall consider in power electronics dc-to-dc circuits. The review of power electronics dc-to-dc converters will be consecutively briefed.

4. Review of voltage dc-to-dc circuits

The dc-to-dc converter is one of the most widely frequent components of all electronic circuits. Looking ahead to the application of this, we find that these converters are very often used with an electrical isolation transformer in the switch-mode dc power converters or without an isolation transformer. They can be sorted into following groups: Step-down (buck); Step-up (boost); Step-down and Step-up (buck-boost). All of them consist of a switch, a diode and an inductor and represent the basic converter topologies. These three switch conditions permit the formation of the three converter topologies, each of which has two switch conditions, diode and switch. Therefore, for only two switch conditions, we have

$$V_{L1} \cdot D + V_{L2} \cdot (1 - D) = 0, \quad (14)$$

where

$$V_L = V_{L1} \quad \dots Q1 = 1; Q2 = 0 \quad \text{or} \quad V_L = V_{L2} \quad \dots Q1 = 0; Q2 = 1. \quad (15)$$

As well now, the fundamental converters listed are shortly discussed in the following and can be seen in Fig. 10.

The output voltage of Buck converter from Fig. 10a is given by (16) and then it is possible write equation (17). The output voltage of Boost converter from Fig. 10b can be written by (18) and for converter from Fig. 10c by (19).

$$V_{out} = (V_{in} - V_{out}) \cdot D - V_{out} (1 - D) = 0, \quad (16)$$

$$V_{out} = D \cdot V_{in} \quad (17)$$

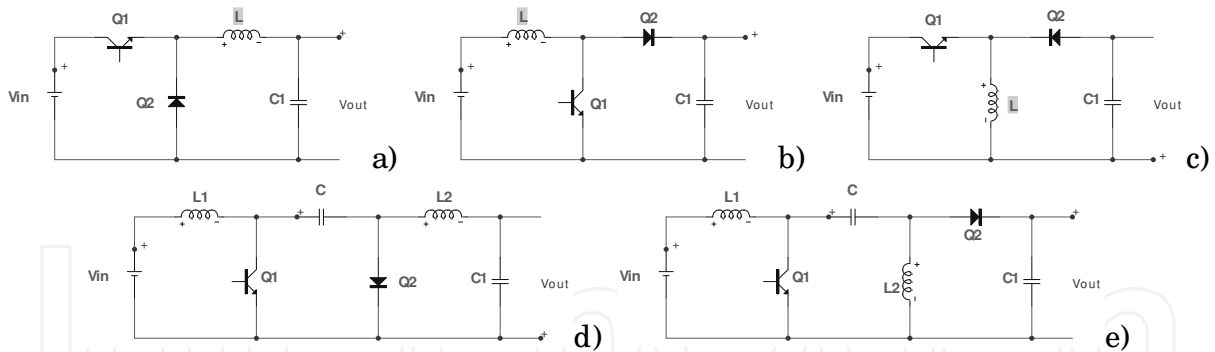

Fig. 10. Dc-to-dc converter a) Buck; b) Boost; c) Buck-Boost; d) Cúk; e) SEPIC

$$V_{\text{out}} = \frac{V_{\text{in}}}{1-D} \quad (18)$$

$$V_{\text{out}} = -\frac{D \cdot V_{\text{in}}}{1-D} \quad (19)$$

These equations and fundamentals topologies from Fig. 10 are well now, but we need show these to explain modes of operations of the following more complicated dc-to-dc converters.

From previous is evident that inductance (L) is one of the most important components of these circuits. For $i_L > 0$, the voltage waveforms are rectangular, being either of amplitude V_{L1} or V_{L2} in accordance with Eq. (15). Therefore, the inductor current is ac (triangular). For very large L, the ac components of the inductor current may be considered negligible (continuous conduction). As L becomes smaller, for a given value of the load (R_L), the ratio of peak inductor current to average inductor current becomes larger. The peak-to-peak sawtooth amplitude becomes large enough that i_L would down below zero (discontinuous conduction). The value of L is defined as a critical inductance L_C for which $i_L = 0$. The following questions show the results of critical inductance criterion. Equations (20) and (21) are for Buck and Boost converter, respectively. (Mitchell, 1998)

$$L_{C \text{ buck}} = \frac{R_L \cdot (1-D)}{2 \cdot f_s} \quad (20)$$

$$L_{C \text{ boost}} = \frac{R_L \cdot (1-D)^2 \cdot D}{2 \cdot f_s} \quad (21)$$

Two very important configurations of dc-to-dc converter using the capacitor as the primary element for storing and transferring energy from input to the output are shown in Fig. 10d and 10e. The advantage of these configurations can be found as the possibility of transformer saturation due to dc offset is precluded by the series capacitor. For converter Cúk and SEPIC, we have

$$V_{\text{out}} = \frac{D \cdot V_{\text{in}}}{1-D} \quad (22)$$

Cúk converter is obtained by using the similarity with buck-boost. Similar to the buck-boost, Cúk converter provides a negative output voltage polarity. An advantage of this Cúk circuit is that the input current are ripple free and it is possible eliminate the ripples completely by means of external inductor filter. Compared SEPIC to Cúk converter, output voltage is preserved and V_C is smaller, what is main reason why use a SEPIC for design with tantalum electrolytic capacitors. The following figures represent test results which were made with focusing on the voltage and current ripple of previous converters.

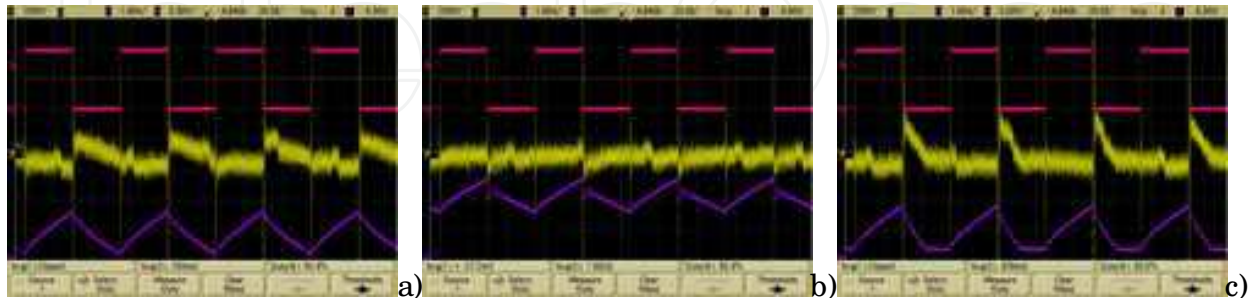

Fig. 11. Converter waveforms a) Boost; b) Buck-Boost; c) SEPIC

($U_{in}=10\text{ V}$, $f_s=20\text{ kHz}$, $L=64\text{ uH}$, $C=330\text{ uF}$, $R=158\text{ }\Omega$, $D=0.5$)

All converters shown above in their basic forms, off the concept from Fig. 10, are capable of transferring energy only in one direction in I-Q. The concept of two-quadrant of dc-to-dc converter operating in I-Q and also in II-Q was shown just in Fig. 7b. This converter topology is capable of a bi-directional power flow and provides the basic topology for a design of bi-directional converters. A full-bridge converter topology from Fig. 9c is also capable of a bi-directional power flow. This capability operates in four quadrants and provides a good system topology, because the output current through these PWM full-bridge dc-dc converter does not become discontinuous. In Fig. 12, the switch utilization factor P_{out}/P_T is shown for the previously considered converters. The switch peak voltage rating V_T and the peak current rating are calculated as $P_T=V_T \cdot I_T$. (Mohan et al., 2002)

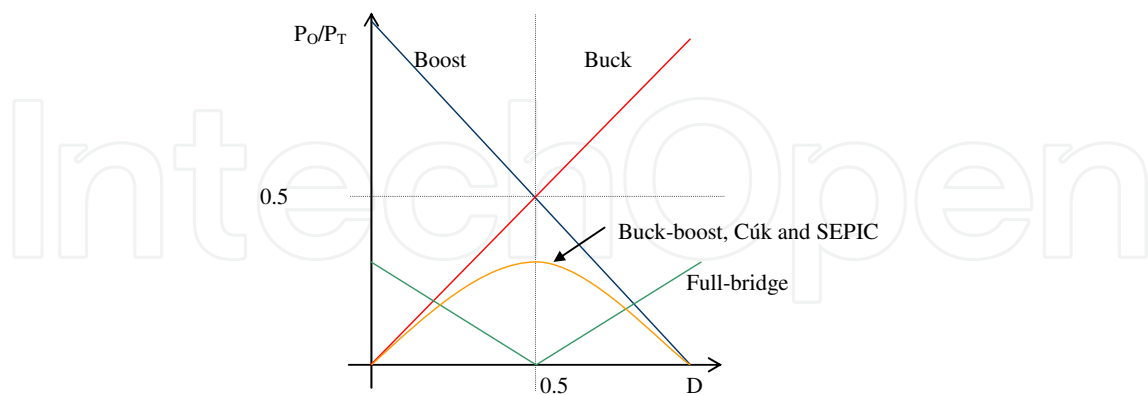

Fig. 12. Switch utilization in dc-dc converters (Mohan et al., 2002)

The new developed converters are created from the dc-to-dc converters e.g. positive Luo-pump, modified Buck-Boost and many others, like switched components SI/ SC, soft-switching ZCS, ZVS, ZT. There are more than 500 existing prototypes of these and can provide the some advantages like lower output voltage ripple in comparison with fundamentals. The output voltage ripple of all developed types is usually lower then 2%.

The positive Luo-pump converter is shown in Fig. 13a. It can be derived from the buck-boost converter. The output voltage is calculated by (22). They work in the I-Q with large voltage gain. The inductor L1 transfers the energy from source to capacitor C during switch-off time, and then the stored energy on C is delivered to the load during switch-on.

Cascade concept of converter can help to implement the output voltage increasing with simpler structure. For example: the basic form of Boost converter was shown in Fig. 10b and output voltage can be calculated by (18). The two-stage boost circuit is set up from boost converter and adding the parts L2, D2, D3 and C2. Output voltage of the first-stage (V1) is also given by (18) and the voltage across capacitor C2 is charged to V_{out} by (23).

$$V_{out} = \frac{1}{1-D} V_1 = \left(\frac{1}{1-D} \right)^2 V_{in} \quad (23)$$

$$V_{out} = \left(\frac{1}{1-D} \right)^3 V_{in} \quad (24)$$

The three-stage and higher-stage connections are derived from the two-stage boost circuit by adding the parts L3, D5, D4 and C3 like in previous case. Then the voltage across capacitor C3 is charged to V_{out} by (24).

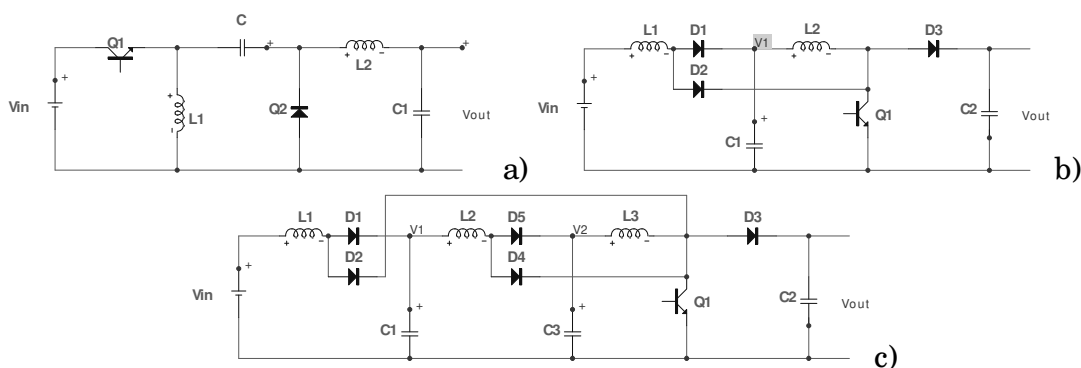

Fig. 13. Developed dc-to-dc converter a) positive Luo-converter; b) Two-stage Boost; c) Three-stage Boost (Luo & Ye, 2000).

Higher stage can be designed by just multiple repeating of parts. Many other circuits can be derived from these baseline topologies using fundamentals converters. Using the analogy of cascade stage converters is evident that these concepts can operate with higher voltage gain, but in the other hand cascade concept require higher number of components such as diodes, inductors and mainly capacitors, what produce lower efficiency and lower reliability. Voltage converters with transformer isolation can provide voltage increasing as well with high efficiency. Fig. 14 shows the most common Buck-transformer isolated voltage converters, called Forward.

The forward converter is a single-ended topology using only one switch Q1. During Q1 (on-time) is Q3 conducted and during Q1 is Q2 (off-time). The use of the forward converter is generally confined to low voltage and power applications. The output voltage can be calculated by

$$V_{out} = D \cdot N \cdot V_{in} , \quad (25)$$

where N is transformer turn ratio. Some of the common modifications of the forward converter topology is shown in Fig. 14b. The two switches Forward converter can operate with voltage rating of the each of the switches are one-half of that in a single-switch topology. The paralleling Forward converters are also common used, where the advantage can be found at high power levels.

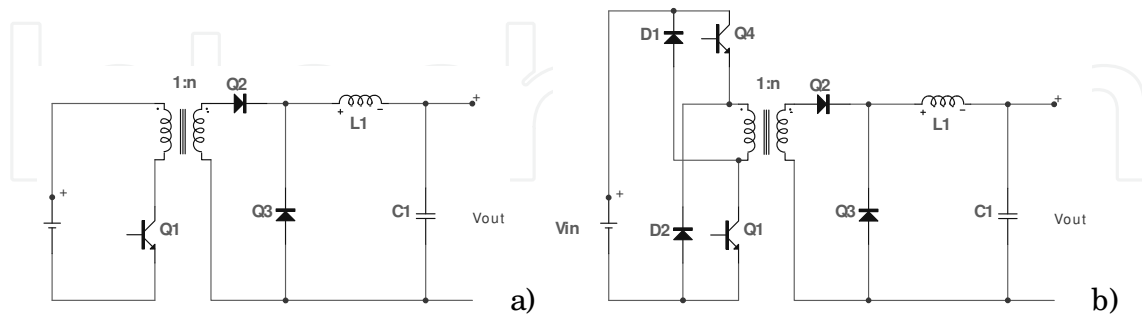

Fig. 14. Buck-derived dc-to-dc converters with transformer isolation (Forward)

The Push-Pull converter topology, which is also based on the Buck topology, can be seen in Fig. 15. These can operate in I-Q and III-Q of the transformer, therefore their are smaller. For a well designed tightly coupled transformer, there is not necessary to use an addition free-wheeling diode for the inductor. The output voltage is equal

$$V_{out} = 2 \cdot D \cdot N \cdot V_{in} \quad 0 < D < 0.5 . \tag{26}$$

However, they are still confined to relatively low input voltage application. (Mitchell, 1998) Fig. 15b shows a push-pull arrangement of the boost converter called Current-fed converter. This converter is particularly useful in high output voltage applications where the inductor prevents what otherwise might be damaging switching current spikes due to the transformer and winding capacitance. The output voltage is equal

$$V_{out} = \frac{N \cdot V_{in}}{1 - D} . \tag{27}$$

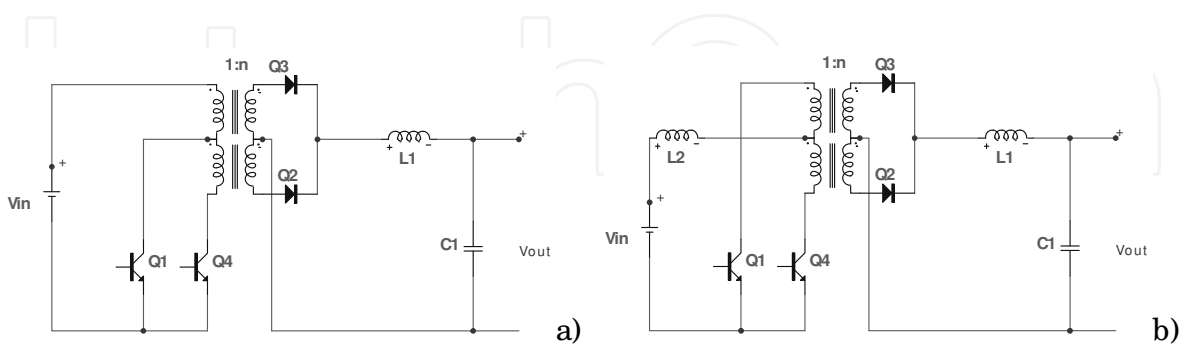

Fig. 15. Buck-derived converters with transformer (Push-Pull); b) Current-fed converter

Fig. 16a and 16b show the Full-bridge and Half-bridge converters which are derived also from Buck converter. Bridge converters are often used for higher input voltage application. The output voltage of Full-bridge is calculated by (26) as well and output voltage of half-bridge is half.

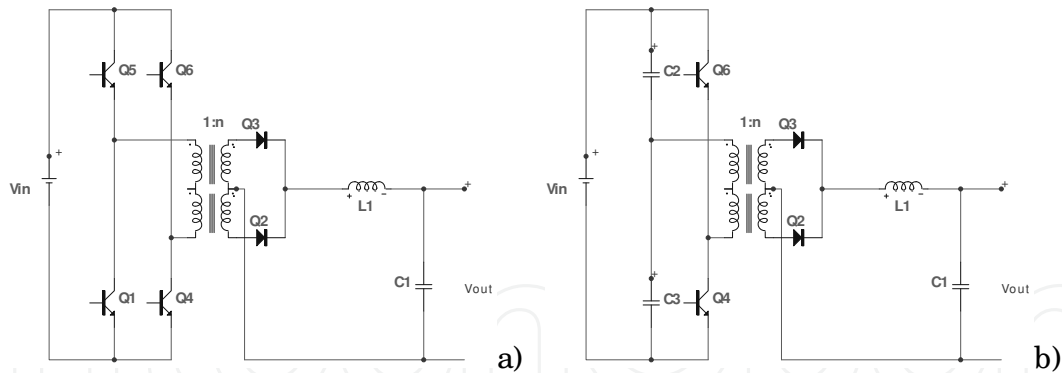

Fig. 16. Dc-to-dc converters with transformer isolation a) Full-bridge; b) Half-bridge

These previous topologies of Boost dc-to-dc concept of converter with transformer isolation can be also build with the bridge configuration. The most common switching converter of dc-to-dc converter with transformer isolation – isolated buck-boost converter, called Flyback and ZETA. The Flyback converter topologies are shown in Fig. 17. The output voltage is calculated of these is by (28). Two transistor concept has advantage of such that the voltage rating of the switches is a one-half of the single-transistor version. The version of paralleling Flyback converters can be found at high power levels, where can be connected more Flyback converts in parallel. The ZETA converters are also a transformer type converter with a low-pass filter. The output voltage ripple is small and output voltage can be calculated also by (28). (Mitchell, 1998).

$$V_{out} = \frac{N \cdot D \cdot V_{in}}{1 - D} \tag{28}$$

The concept of Cúk and SEPIC derived dc-to-dc converters with transformer isolation is shown in Fig. 18a and Fig. 18b.

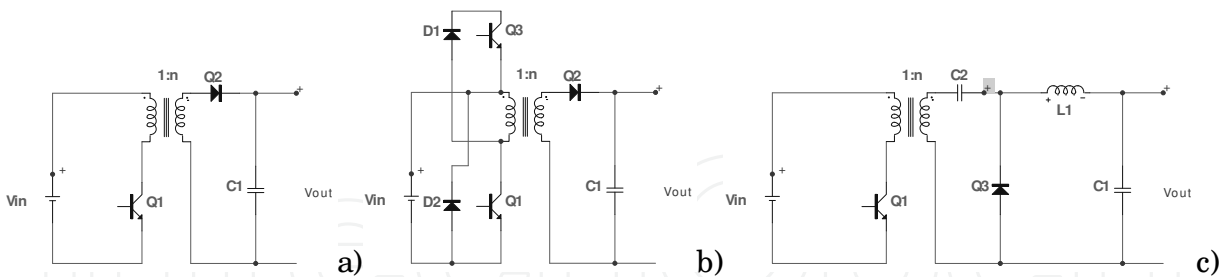

Fig. 17. Buck-Boost derived dc-to-dc converters with transformer isolation (Flyback) a) basic; b) two transistor Flyback; c) ZETA converter

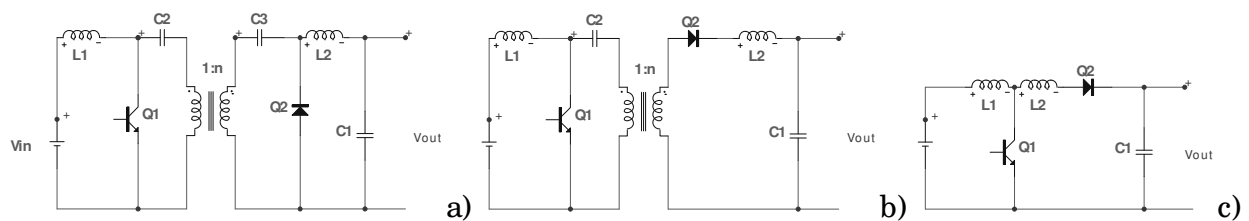

Fig. 18. a) Cúk; b) SEPIC derived dc-to-dc converters with transformer isolation; c) Tapped-Inductor Boost converter

In order to show complete family dc-to-dc converters to achieved higher voltage transformer gain, we need to add next developed converters shortly. For instance, tapped inductor converters are the next most common converters of dc-to-dc converters based on the buck, boost or buck-boost topologies. The example of these converters is shown in Fig. 18c and (Luo & Ye, 2000). Here the tapped inductor ratio is

$$n = \frac{n_1}{n_1 + n_2} \quad (29)$$

The other kinds of converters are based on the technology of Switched-capacitor. These dc-to-dc converters consist of only capacitors without inductors. They have advantages such as lower power losses. Zero-current or voltage switching (ZVS, ZCS) and zero-transition (ZT) converters can performed in two and four-quadrant operation with high power range. Although the treatment of the resonant converters is beyond the scope of this chapter, it should be observed that they are becoming increasingly popular for bi-directional applications (Luo & Ye, 2000).

The final analyses of previous concepts will be discussed in the following. The Buck-Boost dc-to-dc converter (Fig. 10c) is simple concept with low gain of transfer voltage. This topology of converters can be used for high switching frequency, what is good from the view of power density. The disadvantages are no galvanic isolation between input and output and high level of disturbances. Whereas, the various types of dc-to-dc with isolation usually have high transfer voltage gain and high isolation between both sides what is advantage in the comparison with previous fundamentals dc-to-dc converters. Their gain depends on the transformer turn ratio N , which can be 1000. The Flyback converters (Fig. 17) use the demagnetizing effect and works in I-Q. The advantages of this Flyback concept are also simple topology, possibility to use more then one inputs and high efficiency. The disadvantages are design of transformer and also high level of disturbances.

The Boost dc-to-dc converter (Fig. 10b) can be described as well as Buck-Boost like simple circuit for high switching frequency, nevertheless with low level of disturbances and possibilities to operate with continuous current. The disadvantage is non-galvanic isolation and regulation feed-back control is non-stabile. The Buck (Fig. 10a) is also simple and for high switching and operates with high efficiency, on the other hand the concept is with non-galvanic isolation and operates with high efficiency. The concept with Tapped-Inductor Boost converter (Fig. 18c) can achieved higher transfer voltage gain in comparison with Boost concept (Fig. 10b). The other parameters are similar as a Boost.

The Cúk concept (Fig. 10d) operates with high efficiency, continuous input and output current, low level of disturbances, with high switching frequency and with low voltage and current ripple. The disadvantage is also no galvanic isolation between input and output, the output voltage is inverted. The concept of Cúk with transformer (Fig. 18a) has a galvanic isolation and other features are the same as a Cúk concept (Fig. 10d). SEPIC concept (Fig. 10e) are resistant for short-current, wild range of input voltage and both inductances can be at the same core. The disadvantage can be found in higher ripple and these concepts are good only for low power application.

Forward concept (Fig. 14) is also simple circuit with galvanic isolation by transformer and with low level of voltage ripple. The design of transformer is slightly complicated and converter has bad response of load changing. The concept with two-switch has lower request for switch and lower output ripple. The concept with paralleling Forward

converters can be useful for high power. The Push-Pull (Fig. 15) includes a good efficiency and ZETA converter (Fig. 17c) includes a low voltage ripple. The Bridge converters (Fig. 16) are often used for higher input voltage application.

What was shown above, a forward converter is a transformer type buck converter and works in I-Q. Push-pull converter works in push-pull state, which effectively avoids the iron core saturation. The converters which can operate in I-Q and III-Q are Push-pull, Half-bridge and Full-bridge. Therefore, these will be discussed in the following, because these can be used as bi-directional converters.

5. Bi-directional dc-to-dc converter topology for low power application

This part presents the main purpose of this chapter. Bi-directional converters allow transfer of power in either direction according previous part of converter quadrants, where was shown the I-Q and II-Q are necessary for these, or the variant of all quadrants converters. Due to ability of reversing, current direction of flow and voltage polarity must be unchanged; they are being used in application of sources with battery or supercapacitors. Achievable implementation of bi-directional converters can be with hard-switching technology, or with resonant or soft switching technology. All of these lead to an increase components which make decreasing total efficiency and lower reliability. The main points of our focus on these dc-to-dc converters are: high efficiency; high switching frequency; high voltage transfer gain between input and output; low current ripple; to allow bi-directional power control flow; galvanic isolation between input and output; low level of EMI; low stress on the switches.

Therefore, the main goal is finding the middle ground of these previous points. The proposed topologies are a fundamental Buck-Boost concept from Fig. 7, bridge-converters from Fig. 16, a current push-pull (Fig. 15), and tapped inductor (Boost or Buck) converter (Fig. 18c). As was mentioned above, the proposed converter from Fig. 7, is a combination of two well-known topologies, Buck and Boost. The converters provide the bi-directional flow of power for battery charging and discharging using only just one inductor. On the other hand, they require a bulky input inductor L to limit the current ripple, especially when high voltage transfer gain is required. This concept can be used for kW what is main advantage besides simplicity. Other advantages of this concept include low stress on the switches and high switching frequency, low level of disturbances. The both modes (Buck and Boost) operate with high efficiency. The main disadvantage of this is no galvanic isolation between input and output. (Profumo et al., 2006)

To minimise the input inductor size and the current ripple, as well as to reduce the single switch current stress, the previous concept of dc-to-dc converter can be designed with multiple legs interleaving each other by means of an input coupling inductor. The concept is based on the controlling the two identical legs with a phase shifting equal to one-half of the switching period. In this, the current ripple can be reduced and the size of inductor then can be lower than concept with just one inductor (Fig. 7c). Such concept can reduce also switch current stress. Additional advantage of multiple legs of bi-directional Buck and Boost converter is also high power using such as in hybrid electrical vehicles or fuel cell application. To increase its power density, the design can take on a small inductor with multiphase interleaving to operate in discontinuous conduction mode, nevertheless EMI noises increasing.

The first chosen topology was taken from Buck and Boost topology (Fig. 10a and 10b). The second topology being considered is bi-directional concept derived from Buck-Boost (Fig. 10c), which is shown in Fig. 19b. Can be obvious that for I-Q operation is Q1 and D2 switching and Q2 and D1 switching during battery charging (II-Q). The third bi-directional concept of dc-to-dc topology can be seen in Fig. 19c. A Cascade Buck-Boost converter allows controlling in a separate way a switch for each particular condition of operation. The main advantage of this concept is an accurate control of the output voltage by duty cycle. The duty cycle can allow setting from 0 to 1 for both way of current flow. The drawback of cascade concept is double switches and diodes, which are duplicated with respects to the converter arrangement.

The proposed concepts from Fig. 7c, 19b and 19c require just one inductor and two electrolytic capacitors. The current ripple of Cascade Buck-Boost is lower in comparison with a Conventional bi-directional Buck-Boost topology, and requires an inductor with reduced size, what can be beneficial. (Caricchi et al., 1998)

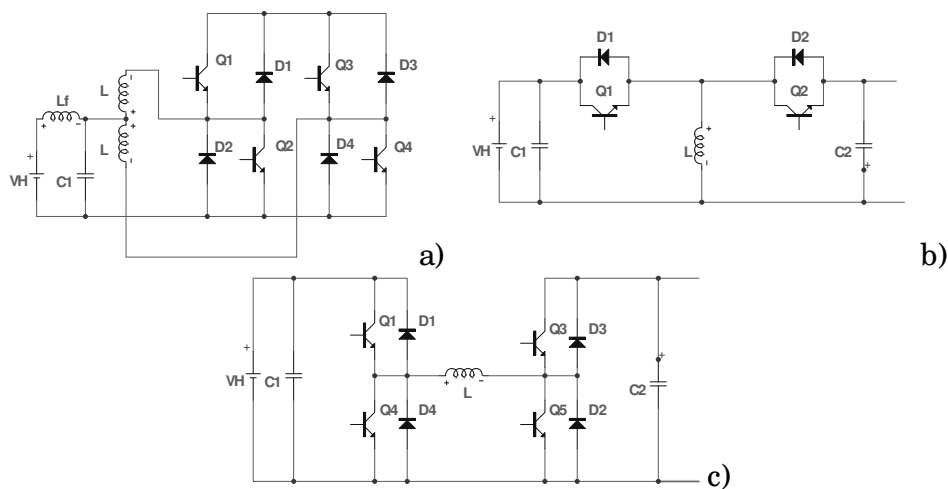

Fig. 19. Bi-directional dc-to-dc converter a) multiple legs Buck and Boost converter); b) Conventional bi-directional Buck-Boost dc-to-dc converter (delivered from Fig. 20); c) Cascade Buck-Boost converter)

The next considered topologies are Cúk, SEPIC and Luo converter. All was shown above for I-Q operation in Fig. 10d, 10e and 13. Circuits show converters these converters, which can operate also in II-Q and therefore are the bi-directional, there are shown in Fig. 20. The multiple-quadrant operation Luo converters are shown in Fig. 20c.

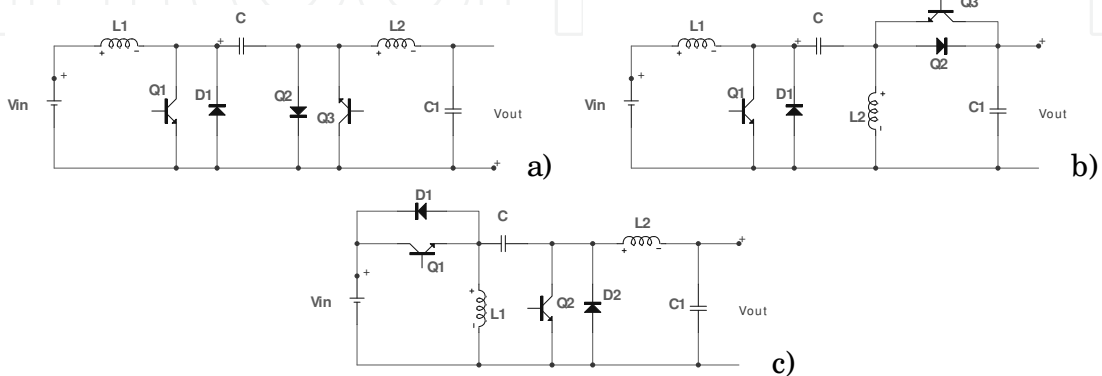

Fig. 20. Bi-directional forms of a, b) Cúk ; c) Luo dc-to-dc converter

Each consists of two switches, two diodes and two inductors. The main advantage is its reduced input and output current ripples with possibility of ripple-free current when integrating the inductances. Certainly, the advantage is also easy system to make isolation between input and output. Nevertheless, the main drawback is requirement of two large inductors and also need a large output capacitor. (Schupbach & Balda, 2003) The next drawback is transfer capacitor, for high power application must be rated at i.e. 600 V, which is actually expensive technology and this concept is available just only for low power application.

Anyway, the main disadvantage of these previous circuits is that the voltage transfer gain is still limited. The concept of dc-to-dc converter with Two-stage according Fig. 12 or Three-stage boost can desire gain improve, but the combination of this with concept from Fig. 19a together is so complicated and the output efficiency of this is out of the ordinary. However, when a very high dc voltage transfer gain is required, a high frequency transformer must be used. As a possible concepts of the most used topologies are the push-pull and Bridge converter. The first one is derived from Buck concept (Fig. 10a) and there were shown in Fig. 15 with diode rectifier on the output. The concept of un-bi-directional can be improved by converter which can also operate in I-Q and II-Q to achieve a bi-directional form of dc-to-dc converter. Therefore, converter consists of two active full-bridge units linked by high-frequency transformer, called dual Full-bridge topology, shown in Fig. 21a.

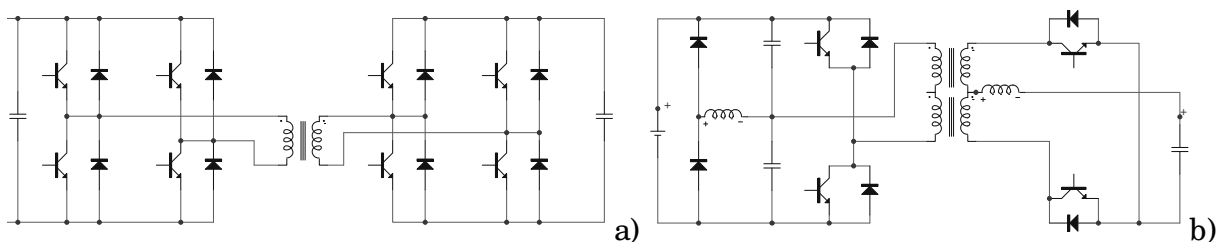

Fig. 21. a) Dual Full-bridge topology; b) Bi-directional dc-to-dc converter of half-bridge + current fed push-pull (Jain et al., 2000)

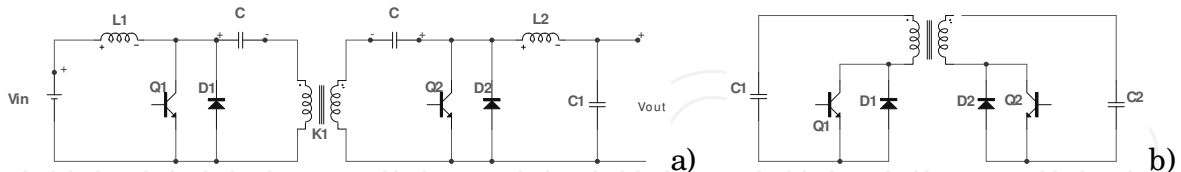

Fig. 22. Bi-directional form of a) Cúk dc-to-dc converter with transformer (Aboulnaga & Emadi, 2004); b) Bi-directional form of Flyback

An additional solution can be proposed by reducing of number of the power switches by means of half-bridge form of dc-to-dc converter. The concepts of bi-directional converters based on the push-pull technology are shown in the following figure (Fig. 21b). The bi-directional converter is set into one by two well-know concept, namely the half-bridge is putted in the primary side and a current fed push-pull (Fig. 15) in the secondary of a high frequency transformer. Such simple concept of galvanic isolated topology provides a good solution of these bi-directional circuits for battery charger circuits of UPS sources. The advantage is a low ripple charging current of battery, low stresses across switches and minimal number of active switches (efficiency). (Jain et al., 2000)

The analyses of current bi-direction dc-to dc converter for low power application, namely for telecommunication system use the concept of Cúk isolated bi-directional converter with integrated magnetics. (Abounaga & Emadi, 2004). The converters provide high efficiency, low noise and low EMI. In addition, the converter features high power density, low cost for low power and electric isolation. These are achieved mainly by integration of magnetic components (input and output inductor). The isolated bi-directional Cúk dc-to-dc converter is shown in Fig. 22a.

A bi-directional Flyback converter concept is shown in Fig. 22b. Advantage of the Flyback concept includes its simplicity, its known dynamic behaviour and its capability of stepping the dc voltage up and down. The drawback is low power using. The push-pull converter is a cost-effective solution for power up-to kW and the control strategy is simple. Anyway, the Bridge concepts can get more wide power ranging and so is used.

The major disadvantages of previous circuits are that the transformer leakage inductance causes high transient voltage across the bridge switches, which increases the switching rating and decreasing the reliability. For closing of this part of this chapter we can affirm that the Cúk, SEPIC and Luo converter are capable for low power application and require two inductors instead one in comparison with basic converters Buck-Boost (Fig. 7). The main advantage of these is its reduced input and output current ripples. The Bridge converters can be proposed with inductor lower in comparison in previous Cúk, SEPIC and Luo converter. Also from above analyses of topology is evident that converters Buck-Boost and Bridge concepts are capable for middle and high power application. In addition, potentially, both can be achieved the highest efficiencies. The main drawback of the Bridge converters is its discontinuous output current, when operating as a boost converter.

The Buck-Boost converter is simple and provides the bi-directional flow of power for battery charging and discharging using just by one inductor. On the other hand, it requires a bulky input inductor L to limit the current ripple, especially when high voltage transfer gain is required. Consequently, the Bridge concept is more frequent for this case of high voltage transfer gain request.

Both (Buck-Boost and Bridge converter) can be used for kW what is our use. Other advantages of the Buck-Boost concept include low stress on the switches and high switching frequency, low level of EMI. They can operate with high efficiency. The main disadvantage of this is no galvanic isolation between input and output. Therefore, the Buck-Boost or Bridge concepts are good candidate for middle power application. (Schupbach & Balda, 2003).

6. A design of bi-directional dc-to-dc converter for EGS

A simplified block diagram of an EGS with variable speed control was shown in Fig. 5. As a consequence of varying the engine speed when using the optimum variable speed control, both the output voltage and the output frequency of the generator vary and must be regulated to a constant value as required by the load. Therefore, a power electronic converter is required to regulate the output voltage and frequency. As mentioned above, the real drawback of EGS with optimum variable speed is the engine-generator dynamics at sudden transients from low load to high load. In case of sudden power output increase, the engine can not deliver the requested torque and the result is further decrease of the speed and torque of the engine until the undesirable stop. The diesel engine has namely a time constant of few second, which is further limited by fuel injection limitation. Therefore at high change of the speed the engine undesirably stops.

Diesel engine coupled with synchronous generator with permanent magnets has been widely used on many power related systems. The output voltage of the generator has an unregulated frequency as it is generated by a varying engine speed. However, the unregulated voltage and frequency of the generator must be changed by power electronics to obtain constant e.g. three-phase ac 400 V/ 50 Hz. Fig. 23 shows the block diagram of the power conversion steps including an ac-dc, dc-dc and dc-ac stage. As can be seen, all power flows from generator to the load through the converter. The fact that power flow through the converter is always makes intention to highlight into efficiency. Furthermore, the output alternating voltage of the EGS must be independent of its load and engine speed.

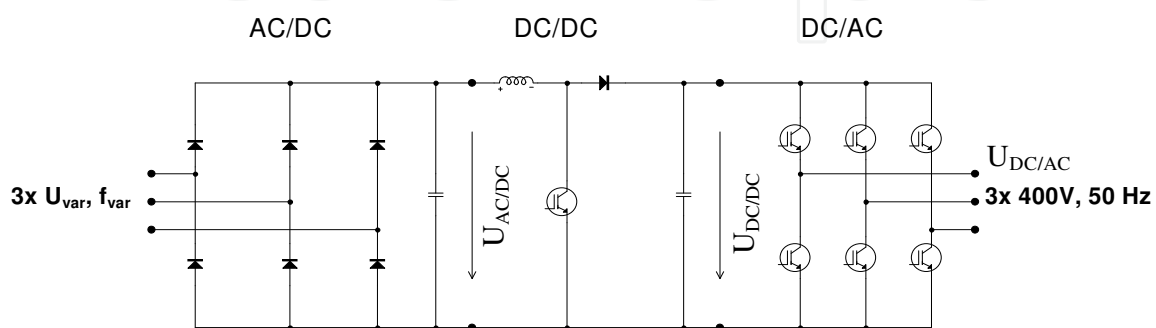

Fig. 23. The power electronics of an experimental model of EGS

As mentioned above and e.g. (Leuchter et al., 2009), the engine rotational speed is to be controlled optimally by adapting the operating strategy for every load to the required output power and torque, while minimizing the fuel consumption. The engine-generator dynamics, during sudden transients from low-load to high-load conditions, still poses a challenge in this regard. The following experimental results (Fig. 24) show the oscilloscope reading of the EGS dynamic behaviour. The measurements were performed in open-loop mode to show the dynamic behaviour of only the generator set with its static speed error e_s (Δ_n) and also to determine the generator set time constant T_C . The yellow curve (CH 1) shows the output current of ac-dc rectifier of power electronics (PE) and the red curve (CH 4) presents the engine speed. The output power is calculated from the output dc-voltage and dc-current. The result of this calculation is shown in Fig. 24 as the violet curve (MATH). The exact point where the load is changed from low load to high load is indicated by arrow A. During time interval t_1 the system was loaded with 640 W at 1560 rpm. During time interval t_2 (580 ms) the load was changed to 2480 W and the transient occurs. Time interval t_3 shows the system operating in steady-state condition. In Fig. 24a drop in speed $\Delta_n = 160$ rpm is shown. This drop in speed corresponds to the static error e_s of the diesel engine inter-regulator. The time constant of a diesel engine T_C is approximately 0.6 s.

Fig. 24b shows a load change, which can cause to stop the diesel engine during time interval t_2 . The engine is unable to sustain the required torque under these conditions, and consequently the EGS is unable to deliver sufficient power to the load. The previous measurements indicate the serious nature of the dynamic behaviour problem associated with the EGS with variable speed: its unsatisfactory reliability during sudden load changes as a result of the inferior dynamic behaviour of the EGS. (Leuchter et al., 2009)

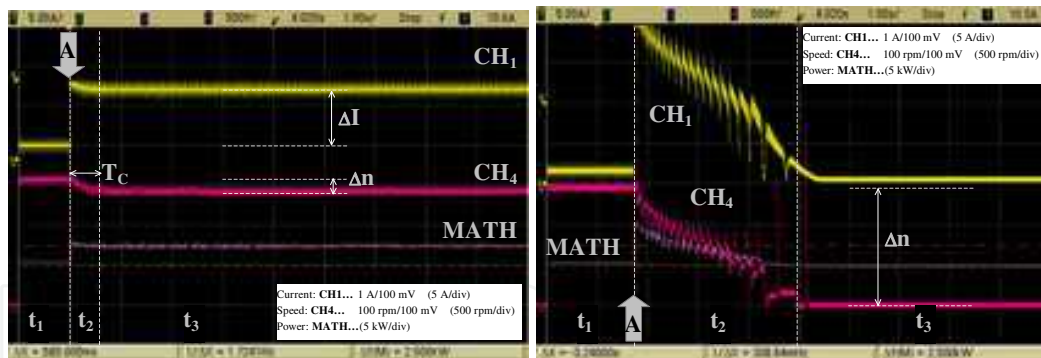

Fig. 24. The oscilloscope record of the load change from a) 0.64 kW to 2.480 kW at engine speed of 1560 rpm b) 0.6 kW to 6 kW at 1440 rpm

An energy buffer, connected via an electronic converter, can improve the dynamic behavior of the EGS system by injecting stored energy into the dc-link by more quadrant dc-dc converter. This concept is based on the delivery of peak power from the energy storage to the link capacitor of the dc-dc converter during the low to high speed transition of the diesel engine. The requested energy W is given by the maximal required power P and the average time of the regulation T_R . For providing 6 kW of power during approximately 4 s with small buffer overlage to have enough energy for change a load during a short time:

$$W = P \cdot T_R \doteq 6000 \cdot 4 = 24 \text{ kJ} \quad (30)$$

$$C = \frac{\Delta t}{\Delta U} \cdot I_d = \frac{\Delta t}{\Delta U} \cdot \frac{P}{U_{DC}} \quad (31)$$

The EGS's energy buffer must therefore provide 24 kJ in order to satisfy the peak energy demand during a speed change. A storage bank, consisting of electrolytic capacitors, is feasible but the energy level of 24 kJ is very high. The electrolytic capacitor can accumulate a low amount of energy in comparison with convenient batteries or supercapacitors. The capacity which is required for 6 kW system is given by Eq. 31, where ΔU is the enabled voltage drop and U_{DC} is the nominal voltage of the dc-link.

Capacity request according Eq. 31 can be implemented by Supercapacitors. The electrical parameters are comparable with batteries. Very low internal resistance can achieve really high discharge currents. Present supercapacitors are readily available with capacity 3500 F. The advantage of supercapacitors is that their electrical characteristics and parameters are keep at -40°C . Interesting result, why use supercapacitors, can be seen in the following Fig. 25. The first reason is a lifetime, second is continues power and temperature range of using. The next advantages of these are good electrical behavior and relatively low initial cost in comparison with modern batteries, such as Li-Pol, Li-Fe (LiFePo₄), Li-Ion and so on. Therefore, supercapacitors are one of the latest innovations in terms of electrical energy storage and its efficiency during charging and discharging is higher than with batteries. The energy stored within the electrical field of a capacitor by reducing its voltage to the half of its initial value can be expressed by the capacitor's state equation:

$$W = \frac{1}{2} \cdot C \cdot \Delta U^2 = \frac{1}{2} \cdot C \cdot \left(U_{\text{nom}}^2 - \left(\frac{U_{\text{nom}}}{2} \right)^2 \right) \quad (32)$$

The value of capacitor is given by:

$$C = \frac{2 \cdot W}{U_{nom}^2 - \left(\frac{U_{nom}}{2}\right)^2} = \frac{2 \cdot 24\,000}{50^2 - \left(\frac{50}{2}\right)^2} \approx 26\text{ F} \tag{33}$$

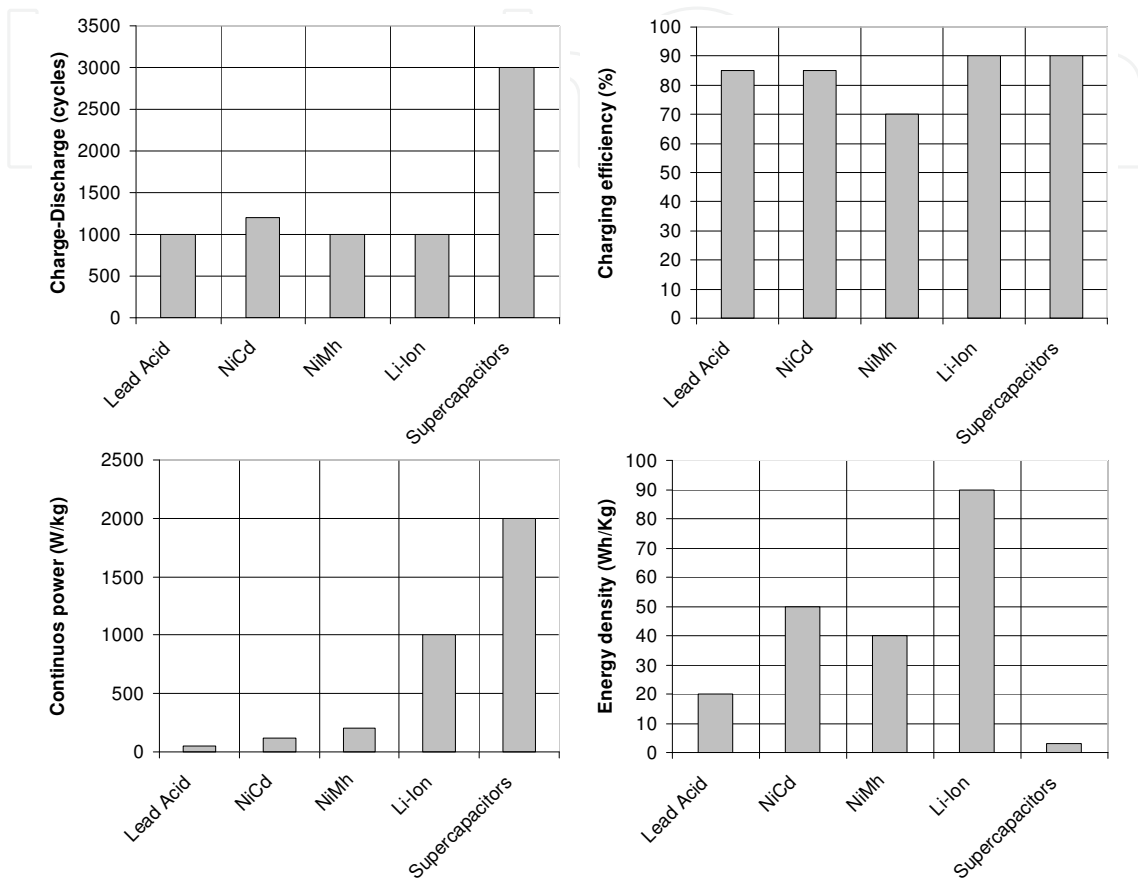

Fig. 25. Battery comparing (Leuchter et al., 2010)

How to set up such power buffer with supercapacitor technology is shown in Fig. 26. Figure shows two main concepts of bi-directional converters, which were described above.

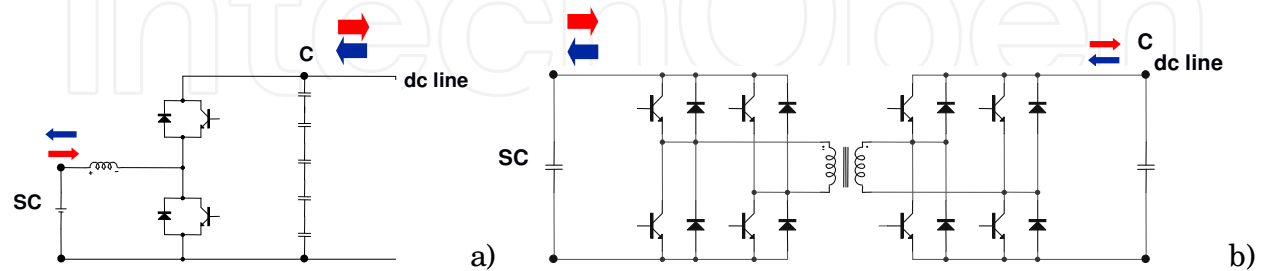

Fig. 26. Concepts of bi-directional converters with supercapacitors

To verify the steady stated and dynamic states performances of basic bi-directional dc-to-dc converter, a small-scale laboratory model where voltage was reduced is built it and set-up. The following block diagram of our experimental set-up of EGS with supercapacitor and bi-directional converter is shown in Fig. 27.

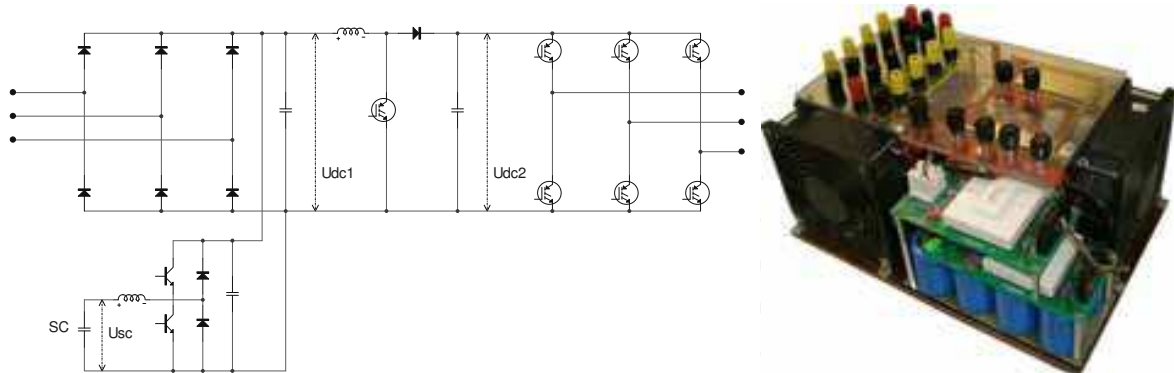

Fig. 27. Concepts of bi-directional converters with supercapacitors

In the experimental set-up, IGBT (SKM100GB128DN, Semikron) are used as switches. At the same time, one power diode bridge (SKD30/12, Semikron) in input are applied. In the following pages we shall discuss some performance evaluations. The value of supercapacitor capacity is equal to the reciprocal of the per-unit of W as defined in (31) and (33). Thus, if the per-unit value of W is 24 kJ and nominal voltage 50 V, the output capacity is 26 F, which is given by (33). Actually, we have selected more over-dimension supercapacitor with 84 F which is directed into the automotive and transportation sector, where the wider range of power delivery requirements. In the experimental set-up, BMOD0083E48 is used. The important parameters of these supercapacitors are: capacitance 83 F; tolerance capacitance $-5\%/ +20\%$; rated voltage 48.6 Vdc; ESRdc 10.3 m Ohm; ESRac 9.8 m Ohm; maximum continuous current 61 A; maximum peak current (1 s) 1090 A; leakage current 3 mA; usable power density 2700 W/Kg; energy available 27 Wh; operating temperature range -40°C to $+65^{\circ}\text{C}$. Charge and discharge characteristics by 10 A during supercapacitor testing are shown in 28.

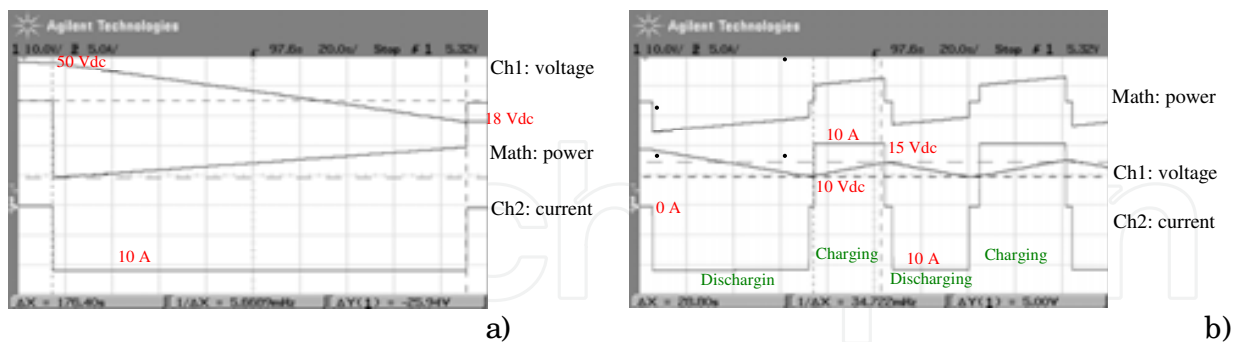

Fig. 28. Charging and discharging of supercapacitor (BMOD0083E48)

Bi-directional dc-to-dc converter according circuit topology from fig. 26a is set-up. The flow of power from or to supercapacitor is controlled according requirements of power management. The Boost mode is given by minimum input voltage 10 V and maximum input voltage 45V. The output voltage is controlled by PID regulator to achieve 100 Vdc voltage output of bi-directional converter. The input and output voltage is shown in Fig. 29. In this figure can be seen the current flowing through L . From these it can be evident that converter conduction operates in discontinuous modes.

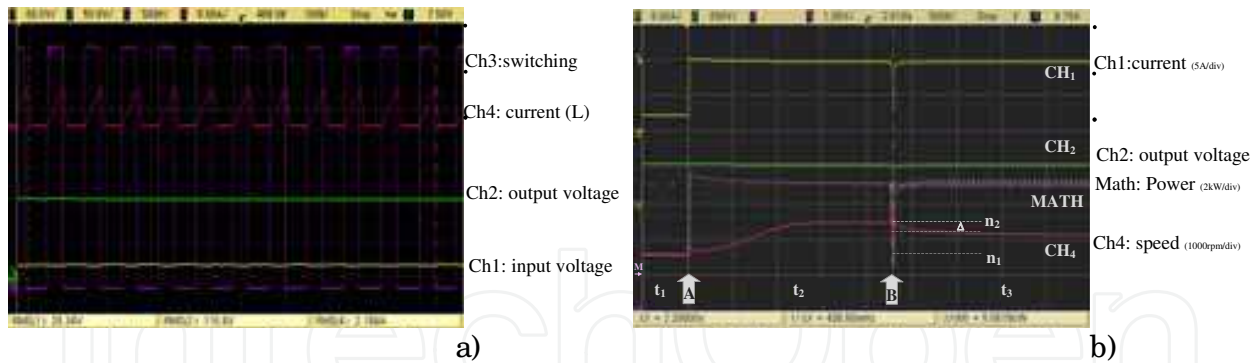

Fig. 29. a) The characteristic of Bi-directional converter with supercapacitor b) The verification of the EGS concept with supercapacitor and bi-directional converter

In accordance with these modes, the outputs voltages are given by (17) and (18). The critical inductance criterions were given in eq. (20) and (21). For very large L , the ac components of the inductor current may be considered negligible with respects to the dc components for the purposes of designing the inductor. As L becomes smaller, for given value of the load resistance, the ratio of peak inductor current to average inductor current becomes larger. However, the peak-to-peak sawtooth amplitude becomes large enough that i_L would dip below zero by increasing R (Mitchell, 1998). In our case, converter can operate in discontinuous conduction modes and output voltage is set by PID regulator. The design specifications of the circuit are shown next. Power of converter is 1 kW; output maximum current is 20 A; maximum $\Delta i_L = 2$ A and switching frequency is selected 20 kHz. The output inductance of inductor can be design about 100 to 500 μH . Magnetic circuit which was chosen is given: U core; 1924 mm^2 ($37 \times 52 \text{ mm}$) and profile $a = 19 \text{ mm}$; $B_{\text{Max}} = 0.3 \text{ T}$; permeability $\mu_{\text{rFE}} = 1000$ a path length $l_{\text{FE}} = 0.28 \text{ m}$. Then number of inductor winding is $N = 200$ and the airgap are $l_v = 0.001 \text{ (m)}$. Therefore, the output L is around 250 μH . The following figures Fig. 30. shows the results of inductance (L) test versus frequency. From this analys is evident that output L a constant, whereas the output resistance are variable, what have effect on the output losses. The following figures show test results of converter as a function of output characteristics versus duty of Boost modes. Fig. 31 also shows the test results of efficiency during Boost mode for bi-directional dc-to-dc converters according Fig. 26a with inductor and Fig.26b with transformer. It can be seen that our efficiency of converter based on the Buck and Boost topology is actually very good.

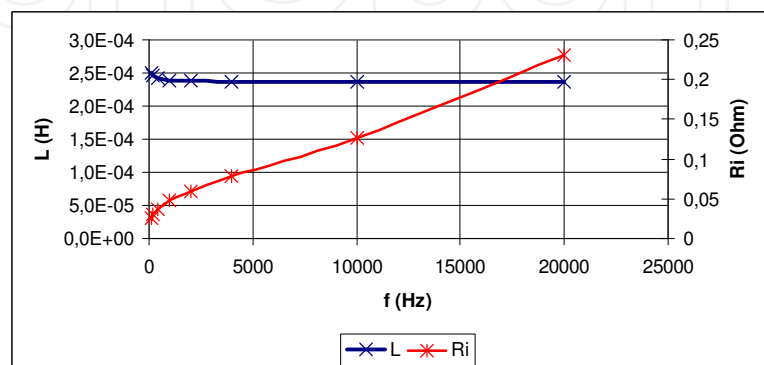
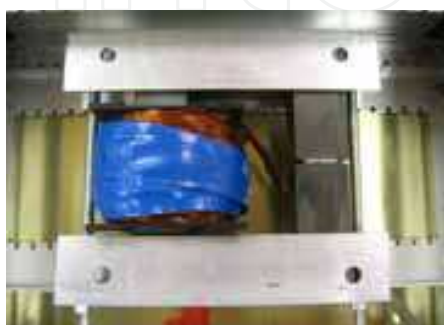

Fig. 30. Inductance versus frequency

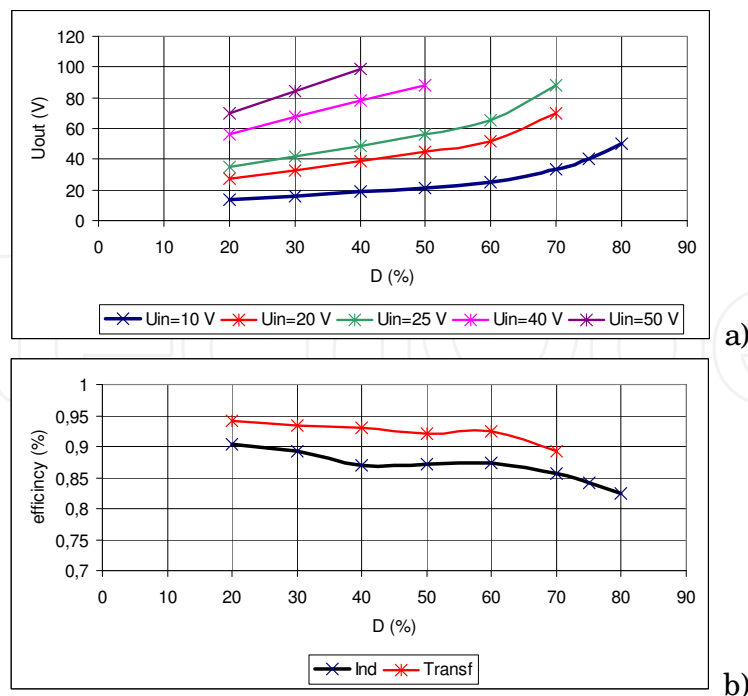

Fig. 31. a) Output characteristics of Boost mode b) Output efficiency

The experimental verification of the EGS concept with supercapacitor and bi-directional converter is shown in Fig. 29b. Channel 1 curve (CH 1) represents the same output current of dc line as was shown in Fig. 24. The red curve (CH 4) shows the engine speed. The output dc voltage is shown by the green curve (CH 2), while the output power is shown as the violet curve (MATH), which is calculated from the output dc voltage and dc current. In time interval T_1 the system was loaded with 1 kW at 1500 rpm. In time interval T_2 the power load was changed from 1 kW to 5.06 kW. During this time (2.28 s) the transition takes place and the power is extracted initially from the energy storage element. Time interval T_3 shows the steady-state condition of the system. It is possible to see that the system is now capable of handling the power load change combined with the feed-back control of the engine speed (set at an optimal speed of the diesel engine). This proves the feasibility of the EGS with variable speed of engine concept.

7. Conclusion

The review of dc-to-dc converter topologies has been shown and dynamic behavior of EGS with power buffer shown that power buffer with supercapacitor and bi-directional dc-to-dc converter can improve dynamic characteristics. This chapter includes detailed bi-directional converter topologies analysis as well as identification of its performance for power buffers. The real drawback of the proposed bi-directional dc-to-dc converters is higher cost because supercapacitor technology is still expensive.

8. Acknowledgment

The research work is supported by the Grant Agency of the Czech Republic (project no. 102/ 09/ 0013)

9. References

- Abounaga, A.A. & Emadi, A. (2004). High performance bidirectional Cuk converter for telecommunication systems, *Proceedings of the INTELEC*, pp. 182-189, ISBN 0-7803-8458-X, 2004
- Blaabjerg, F. & Chen, Z. (2006). *Power Electronics for Modern Wind Turbines*, Morgan and Claypool Publishers, ISBN 1-59829-032-0, USA
- Boeke, U. (2007). High Efficiency Flyback Converter Technology, *Proceedings of the Power Conversion Conference*, pp. 1268-1273, ISBN 1-4244-0844-X, Nagoya, Japan, 2007
- Caricchi, F. et al. (1998). Study of Bi-directional Buck-Boost Converter Topologies for Application in Electrical Vehicle Motor Drives, *Proceedings of the APEC*, pp. 287-293, ISBN 0-7803-4340-9, Anaheim, CA, 1998
- Jain, M.; Jain, P.K. & Daniele, M. (1997). Analysis of a bi-directional DC-DC converter topology for low power application, *IEEE Electrical and Computer Engineering*, Vol. 2, No. 1, (May 1997), pp. 25-28.
- Jain, M.; Daniele, M. & Jain, P.K. (2000). A bidirectional DC-DC converter topology for low power application, *IEEE Transactions on Power Electronics*, Vol. 15, No. 4, (Jul 2000), pp. 595-606.
- Kurka, O. & Leuchter, J (2008). Super-capacitor as Electrical Power Buffers in Military Use, *Proceedings of the 4th International Scientific Conference of The Military Technical Collage (ICEENG)*, 13 p., Cairo, Egypt, 2008
- Luo, F.L. & Ye, H. (2004). *Advanced DC/DC Converters*, CRC Press, ISBN 0-8493-1956-0, Florida, USA
- Leuchter, J et al. (2007). Bidirectional DC-DC Converters for Supercapacitor Based Energy Buffer for EGS, *Proceedings of the EPE Conference*, 10 p., Aalborg, Denmark, 2007
- Leuchter, J (2008). New Generation of Mobile Electrical Power Sources, *Proceedings of the the International Conference on Electrical Machines (ICEM)*, pp. 1366-1369, ISBN 951-22-5097-7, Helsinki, Finland, 2000
- Leuchter et al. (2009). Dynamic Behavior Modeling and Verification of Advanced Electrical-Generator Set Concept, *IEEE Transactions on Industrial Electronics*, Vol. 56, No. 1, (January 2009), pp. 266-279, ISSN 0278-0046.
- Leuchter, J; Bauer, P. & Stekly, V. (2010). Battery-supercapacitors mixed as electrical power buffers, *Proceedings of the 5th IET International Conference on Power Electronics, Machines and Drives (PEMD 2010)*, 6 p., ISBN 978-184919231-6, Brighton, UK, 2010
- Leuchter, J; Bauer, P. & Zobia, A., F. (2010). Power electronics and energy management of hybrid power sources with Supercapacitors, *Proceedings of the 5th IET International Conference on Power Electronics, Machines and Drives (PEMD 2010)*, 6 p., ISBN 978-184919231-6, Brighton, UK, 2010
- Mitchell, D.M. (1998). *DC-DC Switching Regulator Analysis*, McGraw-Hill, ISBN 0070425973, USA
- Mohan, N.; Undeland, T.M. & Robbins, W. (2003). *Power Electronics, Converters, applications and Design*, John Wiley & Sons, Inc., ISBN 0-471-22693-9, USA

- Profomo, F. et al. (2006). Fuel cells for Electric Power Generation: Peculiarities and Dedicated Solutions for Power Electronic Conditions systems, *EPE Journal*, Vol. 16 No. 1 (February 2006). Pp. 44-49.
- Schupbach, R.M. & Balda, J.C. (2003). Comparing DC-DC converters for power management in hybrid electric vehicles, *Proceedings of the IEMDC'03*, pp. 1369- 1374, ISBN 0-7803-7817-2, 2003
- Schupbach, R.M. & Balda, J.C. (2004). 35 KW ultracapacitor unit for power management of hybrid electric vehicles: bidirectional DC-DC converter design, *Proceedings of the PESC*, pp. 2157- 2163, ISBN 0-7803-8399-0, 2004
- Wildi, T. (1997). *Electrical Machines, Drives, and Power Systems*, Prentice Hall Publishers, ISBN 0-13-367889-X, USA

IntechOpen



Energy Storage in the Emerging Era of Smart Grids

Edited by Prof. Rosario Carbone

ISBN 978-953-307-269-2

Hard cover, 478 pages

Publisher InTech

Published online 22, September, 2011

Published in print edition September, 2011

Reliable, high-efficient and cost-effective energy storage systems can undoubtedly play a crucial role for a large-scale integration on power systems of the emerging “distributed generation” (DG) and for enabling the starting and the consolidation of the new era of so called smart-grids. A non exhaustive list of benefits of the energy storage properly located on modern power systems with DG could be as follows: it can increase voltage control, frequency control and stability of power systems, it can reduce outages, it can allow the reduction of spinning reserves to meet peak power demands, it can reduce congestion on the transmission and distributions grids, it can release the stored energy when energy is most needed and expensive, it can improve power quality or service reliability for customers with high value processes or critical operations and so on. The main goal of the book is to give a date overview on: (I) basic and well proven energy storage systems, (II) recent advances on technologies for improving the effectiveness of energy storage devices, (III) practical applications of energy storage, in the emerging era of smart grids.

How to reference

In order to correctly reference this scholarly work, feel free to copy and paste the following:

Jan Leuchter (2011). Bi-Directional DC - DC Converters for Battery Buffers with Supercapacitor, Energy Storage in the Emerging Era of Smart Grids, Prof. Rosario Carbone (Ed.), ISBN: 978-953-307-269-2, InTech, Available from: <http://www.intechopen.com/books/energy-storage-in-the-emerging-era-of-smart-grids/bi-directional-dc-dc-converters-for-battery-buffers-with-supercapacitor>

INTECH
open science | open minds

InTech Europe

University Campus STeP Ri
Slavka Krautzeka 83/A
51000 Rijeka, Croatia
Phone: +385 (51) 770 447
Fax: +385 (51) 686 166
www.intechopen.com

InTech China

Unit 405, Office Block, Hotel Equatorial Shanghai
No.65, Yan An Road (West), Shanghai, 200040, China
中国上海市延安西路65号上海国际贵都大饭店办公楼405单元
Phone: +86-21-62489820
Fax: +86-21-62489821

© 2011 The Author(s). Licensee IntechOpen. This chapter is distributed under the terms of the [Creative Commons Attribution-NonCommercial-ShareAlike-3.0 License](#), which permits use, distribution and reproduction for non-commercial purposes, provided the original is properly cited and derivative works building on this content are distributed under the same license.

IntechOpen

IntechOpen