

We are IntechOpen, the world's leading publisher of Open Access books Built by scientists, for scientists

4,800

Open access books available

122,000

International authors and editors

135M

Downloads

Our authors are among the

154

Countries delivered to

TOP 1%

most cited scientists

12.2%

Contributors from top 500 universities



WEB OF SCIENCE™

Selection of our books indexed in the Book Citation Index
in Web of Science™ Core Collection (BKCI)

Interested in publishing with us?
Contact book.department@intechopen.com

Numbers displayed above are based on latest data collected.
For more information visit www.intechopen.com



Optofluidic Compound Lenses Made with Ionic Liquids

Sergio Calixto¹, Martha Rosete-Aguilar², Francisco J. Sanchez-Marin¹,
Olga L. Torres-Rocha¹, E. Militza Martinez Prado¹
and Margarita Calixto-Solano³

¹*Centro de Investigaciones en Óptica, León, Gto.;*

²*Centro de Ciencias Aplicadas y Desarrollo Tecnológico,
Universidad Nacional Autónoma de México;*

³*Instituto Tecnológico y de Estudios Superiores de Monterrey, Monterrey,
Mexico*

1. Introduction

Traditional optical materials comprise glasses, metals, plastics and crystals to mention but a few. The fabrication of optical elements with these materials gives passive elements. However, actual needs demand for dynamical elements with surfaces that can be modulated. To achieve this function several methods have been developed. For example deformable mirrors are used in astronomy to improve the image of stars. Other methods use fluids to achieve the deformation. They are called optofluidic methods. Among the optofluidic elements are the membrane liquid lenses (Erickson et al., 2008; Kuiper & Hendriks, 2004; Werber & Zappe, 2005; Ren & Wu, 2007; Sai et al., 2008; Zeng & Jiang, 2008; Calixto et al, 2009; Yu et al, 2009; Hu et al., 2009; Xu et al., 2010, Zhang et al., 2011). Thus, the optical liquid that composes the lenses is a key element. Due to the good characteristics of ionic liquids, described in section 2, we began a study to find the optical features of some ionic liquids. We hope that the results of the study could be taken as a basis to use the ionic liquids in some optical applications.

Optical liquids should have a specific refractive index and dispersion, thermal stability, low toxicity, transparency for the intended working wavelengths, low cost and compatibility with the material that encloses them. In the past we have suggested briefly the use of ionic liquids as the liquid that composes optofluidic varifocal lenses (Calixto et al, 2009). Now in this chapter a more in-depth optical study of ionic liquids is presented. The paper is organized as follows: Section 2 describes briefly ionic liquids; Section 3 exposes the results of an optical and a thermal study made to some ionic liquids; as an example of an application of ionic liquids we describe in Section 4 an optical design that was developed considering the optical properties of the studied ionic liquids. Following sections describe the efforts to fabricate a compound lens. In section 5 is described the fabrication of cells, that behave as lenses, and contain the ionic liquids. These cells have a flat glass on one end and a flexible membrane on the other side. Section 6 shows the results of a mechanical study made to the membranes. This study shows the profile of the membranes when they are under pressure or vacuum. Section 7 shows the results of an optical study made to cells to find the relation between the pressure applied to the cell and the radii of the membranes. Section 8 describes

the experimental behavior when a compound two-cell lens is used to form images. This compound lens changes its focal length by changing the pressure in each cell. Finally in Section 9 we conclude.

2. Ionic liquids

The development of ionic liquids goes back to 1914. First research efforts dealt with the synthesis of ethylammonium nitrate (Wasserscheid & Keim, 2000). Later the first ionic liquid with chloroaluminate ions was developed in 1948 by Hurley and Wier, at the Rice Institute in Texas, as bath solutions for electroplating aluminum. However, these systems were not studied further until the late 1970s when the groups of Osteryoung and Wilkes rediscovered them (Wasserscheid & Keim, 2000). In the early 1980s the groups of Seddon and Hussey began to use chloroaluminate melts as nonaqueous, polar solvents for the investigation of transition metal complexes (Wilkes, 2002). Spectroscopic and complex chemistry experiments followed. It is specially to Seddon's work that ionic liquids became more familiar to broad public (Freemantle, 2007).

The use of ionic liquids as solvents for homogeneous transition metal catalyst was described in 1990 by Chauvin et al. and by Wilkes et al. (Wasserscheid & Keim, 2000). The concept of ionic liquid received an impulse by the work of Wilke's group when they described in 1992 the synthesis of systems with significantly enhanced stability against hydrolysis (Wasserscheid & Keim, 2000).

Ionic Liquids (ILs), containing essentially only ions, have been considered as a group of environmentally friendly solvents with unique properties, such as negligible vapor pressure, thermal and chemical stability, recyclability, and nonflammability.

Ionic Liquids have also attracted great attention among scientists because they are versatile in terms cations, anions, and their combinations, which make their properties designable according to different requirements. An ionic liquid is a salt with a melting temperature below the boiling point of water. Most salts identified in the literature as ionic liquids are liquid at room temperature, and often to substantially lower temperatures. Ionic liquids possess a high degree of asymmetry that frustrates packing and thus inhibits crystallization (Wilkes, 2002).

2.1 Ionic liquid synthesis

The initial step in the synthesis of ionic liquids is the quaternization of an amine or phosphane to form the cation. The most important reported cation types are shown in Figure 1. Salts with different anions are obtained by the quaternization reaction depending on the alkylation reagent, Figure 2. Melting points under 100 °C can be obtained for a series of cation/anion combinations with this method (Table 1).

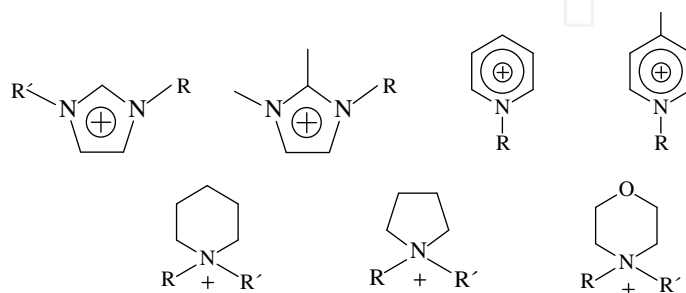

Fig. 1. Important types of cations in ionic liquids. R and R' are lineal chains: ethyl, propyl, butyl, pentyl, hexyl.

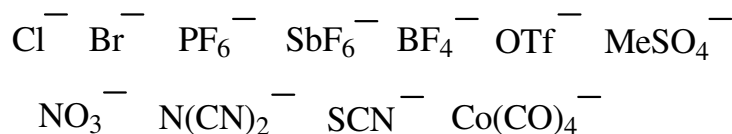

Fig. 2. Different anions that configure the ionic liquids.

Ionic liquid	Alkylation reagent	m. p. [°C]
[EMIM]CF ₃ SO ₃ ^(a)	methyl triflate	-9
[BMIM]CF ₃ SO ₃ ^(b)	methyl triflate	16
[Ph ₃ POc]OTs ^(c)	OcOTs	70-71
[Bu ₃ NMe]OTs	MeOTs	62
[BMIM]Cl	chlorobutane	65-69

^(a) EMIM = 1-ethyl-3-methylimidazolium; CF₃SO₃ = triflate anion; ^(b) BMIM = 1-*n*-butyl-3-methylimidazolium; ^(c) Oc = octyl; ; Ts = H₃CC₆H₄-SO₂ (tosyl).

Table 1. Examples of ionic liquids that can be formed by direct quaternization.

It should be noted that the synthesis of highly pure, binary ionic liquids places particular demands on the preparative work. The purity of the system is essential for many solvent applications and for the characterization of their physical and chemical properties (Wasserscheid & Keim, 2000).

2.2 Important properties

Density. In general ionic liquids have a larger density value than the density of water. For example, [BMIM][PF₆] has a density of 1.37 g/cm³ at 20°C. The density of ionic liquids decreases when the N-alkyl chain length increases.

Viscosity. The viscosity of ionic liquids is essentially determined by their tendency to form hydrogen bonding and by the strength of their Van Der Waals interactions. Ionic liquids are generally more viscous than molecular solvents. The Ionic liquid's coefficients of viscosity at room temperature are between 10 and 1000 centipoises. The viscosity increases when the cation size and alkyl chain length increases. An example of this phenomenon is shown in Table 2.

Melting point. A key criterion for the evaluation of ILs is the melting point. This point for some ILs could be in the range from -90 °C to 200 °C.

Thermal stability. Some ionic liquids used as solvents are so stable that the upper temperature limit is not a problem for their employment.

	Anion [A] ⁻	η [cP]
	CF ₃ SO ₃ ⁻	90
	<i>n</i> -C ₄ F ₉ SO ₃ ⁻	373
	CF ₃ COO ⁻	73
	<i>n</i> -C ₃ F ₇ COO ⁻	182
	(CF ₃ SO ₂) ₂ N ⁻	52

Table 2. Dynamic viscosities η of various 1-*n*-butyl-3-methylimidazolium (BMIM) salts at 20 °C.

Solubility. Due to their ionic nature and to their organic composition ILs are able to dissolve organic and inorganic compounds and sometimes even polymeric materials. This feature makes ILs attractive, not only as solvents for chemical processes, but also for the separation and extraction of materials from solutions and mixtures.

Toxicity. Although ILs impact in air pollution is insignificant due to their very low vapour pressure, their solubility (being of ionic nature) in water is high (Pham et al., 2010). It is necessary to be aware of the potential environmental risks of ILs (Romero, 2008; Wasserscheid & Keim, 2000).

2.3 Potential applications of ionic liquids

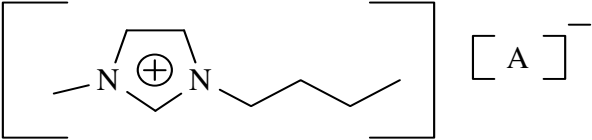
Ionic liquids are versatile liquids that have recently been used in researches concerned with macromolecules. The main reports on ionic liquids and polymers concern its use as polymerization solvents. Also, ionic liquids are currently being used as solvent or additives for macromolecules (Ueki & Watanabe, 2008).

Liquids Separations. Since the choice of cation and anion provides an opportunity to tailor the solubility of various compounds in the ionic liquids, these new compounds should have applications in the selective separation of liquids. This concept was explored by Fadeev and Meagher (Brennecke & Maginn, 2001) who used ionic liquids to separate alcohols from a fermentation broth. In the same field, Rogers and coworkers (Freemantle, 2007) explored the use of ionic liquids/aqueous biphasic systems with added chelating agents to perform metal extractions (Wasserscheid & Keim, 2000).

Lubricants. The characteristics of high thermal stability and large liquid range makes ionic liquids good candidates for lubricants in high-temperature and/or low pressure applications.

Green Chemistry. Recently, ionic liquids have been extensively evaluated as environmentally friendly or "green" alternatives to conventional organic solvents for a broad range of organic synthetic applications. In addition, ionic liquids have been used as catalysts, in organic synthesis, in compositions for stabilizing and/or isolating nucleic acids in or from micro-organisms, as process aids for the synthesis of polynucleotides, as lubricants and for the preparation and stabilization of nanoparticles. Furthermore, after the announcement of the first industrial process involving ionic liquids by BASF (BASIL process) in 2003, the potential of ionic liquids for new chemical processes and technologies is beginning to be recognized (Weyershausen & Lehmann, 2004).

Optical applications. Application of ionic liquids in photophysical studies depends on its transparency in the optical region. Behavior of some imidazolium ionic liquids concerning its UV-visible absorption and fluorescence has been studied (Aniruddha & Anunay, 2006). An important characteristic of these materials is that some of them possess liquid crystal properties, which indicate that these compounds may present large nonlinear optical responses (Souza et al., 2008; Aniruddha & Anunay, 2006). Researchers at some laboratories are using ILs as optical immersion fluids for examining inclusions in gems and minerals (Freemantle, 2007). Besides this application, ILs have been suggested as the base for an extremely large diameter spinning liquid mirror telescope (Borra et al. 2007). Research groups have suggested the use of ionic liquids in optofluidic varifocal compound lenses (Calixto et al. 2009).

More recently, the influence of ionic liquids in photopolymerizable holographic materials has been investigated (Lin et al., 2011). Ionic liquids structure has an important effect on the characteristics of polymeric materials. An extensive investigation of the influence of ionic

liquids on photopolymerizable holographic materials is of interest from both fundamental and application aspects.

3. Optical and thermal characterization of ionic liquids

3.1 Optical studies

From the optical point of view conventional optical materials, like glasses or plastics, are well characterized. By looking at the manufacturer catalogs for optical glass and plastics (www.us.schott.com; www.ohara.corp.com/index.html; Mills, 1986; Simonds, 1964) it is possible to find the properties of tens of glasses and plastics. Among those properties are the chemical, thermal, mechanical (micro hardness) and optical. Chemical properties include climate, staining, acids and alkali resistance. Thermal properties include viscosity and thermal expansion. Optical properties include refractive index and dispersion, secondary spectrum and internal transmittance, to mention but a few.

The refractive index (n) of the materials is a function of the wavelength of light (λ).

Refractive indices are given in the manufacturer's data sheets for each type of glass. Refractive indices of optical materials are measured at some specific wavelengths (Malacara & Thompson, 2001). For example at the yellow sodium D line (589.2 nm), blue hydrogen F line (486.1 nm), red hydrogen C line (656.2 nm) and yellow helium d line (587.5 nm). The difference in refractive index $n_F - n_C$ is described as the "principal dispersion".

Another quantity that determines the chromatic dispersion is the Abbe value for the D line $V_D = (n_D - 1)/(n_F - n_C)$. A diagram relating the refractive index n_D vs. Abbe value is given by the manufacturers (www.schott.com; www.oharacorp.com/index.html). Each point in the diagram represents a glass. Glasses are somewhat arbitrarily divided in two groups, the "crown" glasses and the "flint" glasses. Crowns have an Abbe-value of 50 or more, flints 50 or less (Smith, 1966).

Next we show the results of a characterization optical study of some ionic liquids. Ionic Liquids considered were [EMIM][BF₄], [EMIM][TA], [BMIM][TA], [BMIM][BF₄], [BMIM][TF₂N], [EMIM][TF₂N], [EMIM][CF₃COO], [BMIM][CF₃COO], [BMIM][PF₆], [BMIM][NO₃], [BuPy][BF₄], [MePyrr][HSO₄], [BuPy][TF₂N]. Their fabrication method can be found in reference (Calixto et al, 2009).

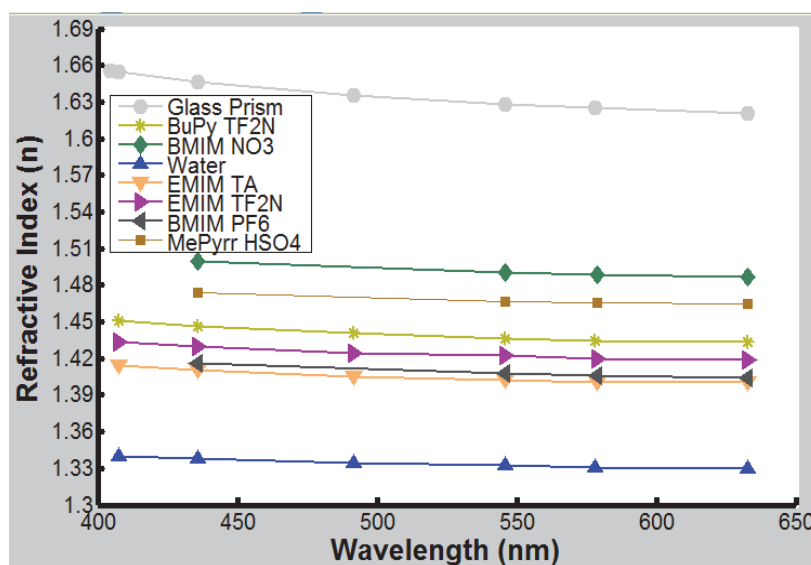

Fig. 3. Behavior of refractive index vs. Wavelength.

For some of these liquids we found the behavior of the refractive index (n) as a function of some wavelengths (λ). To do this we used a spectroscope. We have not tested all the ionic liquids mentioned above because some of them had close refractive indices. Plot in Fig. 3 shows the results. Also in Fig. 3 is shown the behavior for distilled water, and a glass.

To interpolate refractive index values between measured points we used the Sellmeier or Cauchy equations (Smith, 1966). n_D , n_F and n_C values were calculated with these equations and are shown, together with Abbe values, in the upper part of Table 3. Lower part of Table 3 show values of some glasses taken from data sheets (www.us.schott.com; www.cargille.com).

Material	n_D ($\lambda = 0.5893$ microns)	n_F ($\lambda = 0.4861$ microns)	n_C ($\lambda = 0.6563$ microns)	$n_F - n_C$	V-value
Water	1.3309	1.3348	1.3292	0.0056	58.77
EMIM [TA]	1.4009	1.4051	1.3999	0.0051	78.08
BMIM [PF ₆]	1.4059	1.4112	1.4040	0.0072	56.29
EMIM [TF ₂ N]	1.4200	1.4250	1.4183	0.0067	62.52
BuPy [TF ₂ N]	1.4346	1.4409	1.4324	0.0085	51.15
MePyrr [HSO ₄]	1.4655	1.4696	1.4645	0.0051	91.30
BMIM [NO ₃]	1.4881	1.4943	1.4856	0.0086	56.68
Glass Prism	1.6242	1.6363	1.6194	0.0169	36.91
BK7 [15]	1.5158	1.5224	1.51432	0.008054	64.17
PK1 [15]	1.50378	1.5090	1.50146	0.007528	66.92
FK1 [15]	1.47069	1.4755	1.46853	0.006990	67.34
BaFN10 [15]	1.67003	1.68001	1.66579	0.01422	47.11
BaK4 [15]	1.56883	1.57590	1.56576	0.01014	56.13
Immersion Oil (Type B) [21]	1.515	--	--	--	43.2

Table 3. Optical characteristics of some materials. In the upper part are shown data obtained through the experiment. Data in the lower part was obtained from references (www.us.schott.com; www.cargille.com).

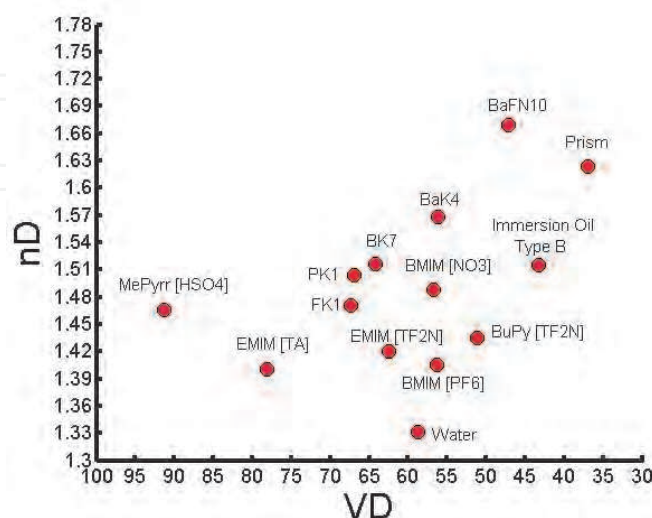

Fig. 4. Abbe Diagram n_D - V_D .

In Fig. 4 is shown the n_D - Abbe value diagram for the materials displayed in Table 3. Here we can notice that most of the ionic liquids have a lower refractive index than the glasses show. Notice that the ionic liquid MePyrr[HSO₄] shows a high Abbe number (91.3) and a refractive index of 1.465. These characteristics were useful when the design of multichamber lenses was done (Section 4).

3.2 Thermal study

It is common that optical elements are used in environments where temperature changes. We investigated the refractive index behavior of some ionic liquids when temperatures above room temperature were reached. The temperature ranged from about 18 °C to about 95 °C. Ionic liquids tested were MePyrrHSO₄, EMIM BF₄ and EMIM[TA]. As a reference we also tested water. Results can be seen in Figure 5.

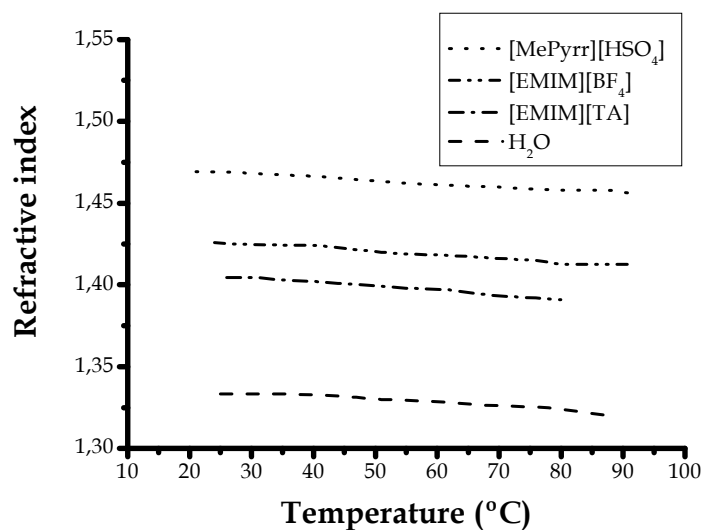

Fig. 5. Behavior of refractive index as a function of temperature for some ionic liquids and water.

4. Optical design

As an example of application of ionic liquids we developed the design of an achromatic varifocal multichamber lens. This lens was first designed by Reichelt and Zappe (Reichelet and Zappe, 2007). Liquids suggested in this reference were commercial (www.cargille.com). An $f/3.6$ achromatic lens with a positive focal length of 14.4 mm (Fig. 6a), and a negative focal length of -14.4mm (Fig. 6b), was designed by Reichelt and Zappe. The design consists of three chambers (1), (2) and (3). Each chamber is separated by a 400 μm thin, low-dispersive silica glass plate which is also used for the front and back covers. It is supposed that a thin membrane, within each chamber, separates two liquids or a liquid and air. By changing the pressure in the chamber the membrane profile changes. Chamber (1) contains a crown-like liquid in air, (2) contains the same crown-like liquid and a flint-like liquid and (3) contains the same flint-like liquid in air. The refractive indices, dispersions and Abbe-values are given respectively by: $n_1 = 1.3250$, $\Delta n_1 = 0.003788$, $V_1 = 85.8$ for the crown-like liquid and $n_2 = 1.5000$, $\Delta n_2 = 0.0120$ and $V_2 = 41.7$ for the flint-like liquid.

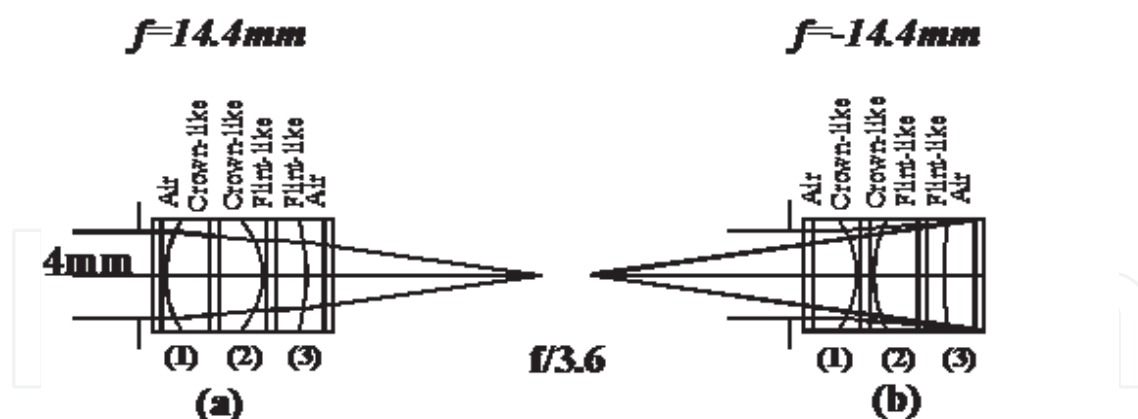

Fig. 6. Diagrams for the lens designed by Reichelet and Zappe. a) Focal distance is positive, b) focal distance is negative.

In our case by looking at the diagram of n_D -Abbe value (Fig. 4) we found that the combination of ionic liquids MePyrr[HSO₄] and BMIM[NO₃] was able to provide a similar achromatic lens having the same f -number, $f/3.6$, and working with the same focal length interval between -14.4mm and 14.4mm . A second combination that can provide an achromatic lens is given by the pair EMIM[TA] and BuPy[TF₂N] ionic liquids. This lens is achromatic within the focal interval -14.4mm and 14.4mm but working with a larger f -number given by $f/4.8$. In each combination the first liquid works as a crown-like and the second as a flint-like liquid. The layouts for the MePyrr[HSO₄] and BMIM[NO₃] combination (EMIM[TA] and BuPy[TF₂N] combination) are shown in Figures 7a (7c) and 7b (7d) for positive and negative focal length respectively.

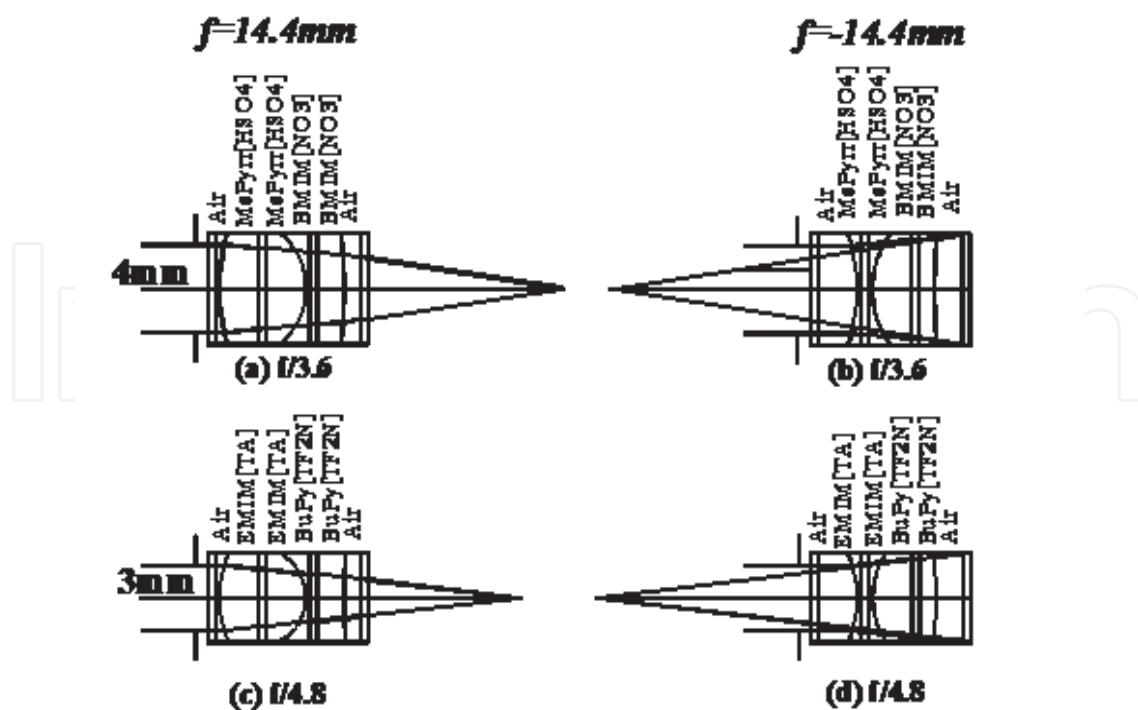

Fig. 7. Layouts for (a,b) the lens with liquids MePyrr[HSO₄] and BMIM[NO₃] and (c,d) the lens with liquids EMIM[TA] and BuPy[TF₂N].

The transverse ray aberrations for the achromatic lens designed by Reichelt and Zappe, shown in the first row for a positive and negative focal length, and for the lenses with ionic liquids are plotted in Fig. 8 for comparison. The transverse ray aberration for the MePyr[HSO₄] and BMIM[NO₃] and for the EMIM[TA] and BuPy[TF₂N] ionic liquids are shown in the second and third row respectively for positive and negative focal lengths. The transverse ray aberration is plotted as a function of the aperture of the lens for three wavelengths: 589.3nm, 486.1nm and 656.3nm. The distance between parallel lines is given by the diameter of the airy disk diffraction pattern.

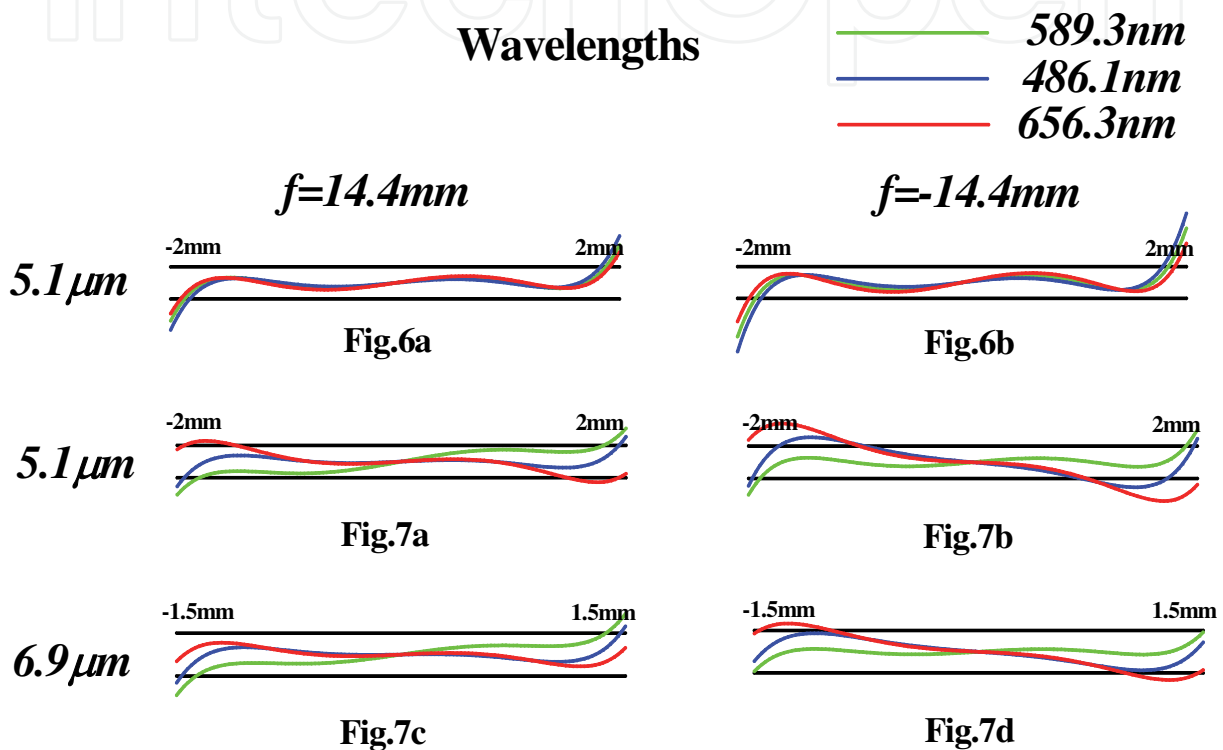

Fig. 8. Transverse ray aberrations.

As can be seen, the ionic liquids also give a nearly diffraction limited achromatic lens almost as good as the achromatic lens designed by Reichelt and Zappe, although the latter gives a better color correction, providing a practically apochromatic lens.

5. Liquid cell fabrication

To implement the ideas exposed in the preceding optical design section (4) we followed the next method. Each cell was made with a clear square acrylic block (11mm X 11mm). Thickness of each block was 4.6 mm. A hole with a diameter of 4.2 mm was drilled in the block center. This hole was used as the liquid chamber. Two small holes, 90° apart, were drilled on the sides of the block. In each hole a syringe needle was glued. Through one needle the liquid was fed into the chamber and through the second needle air was drained. Ends of the acrylic block were covered one with a thin flat glass plate (150 μm thick), the other with a thin silicone membrane. Figure 9 shows side and plain diagrams of the cell. Figure 10 is a photograph of a fabricated cell.

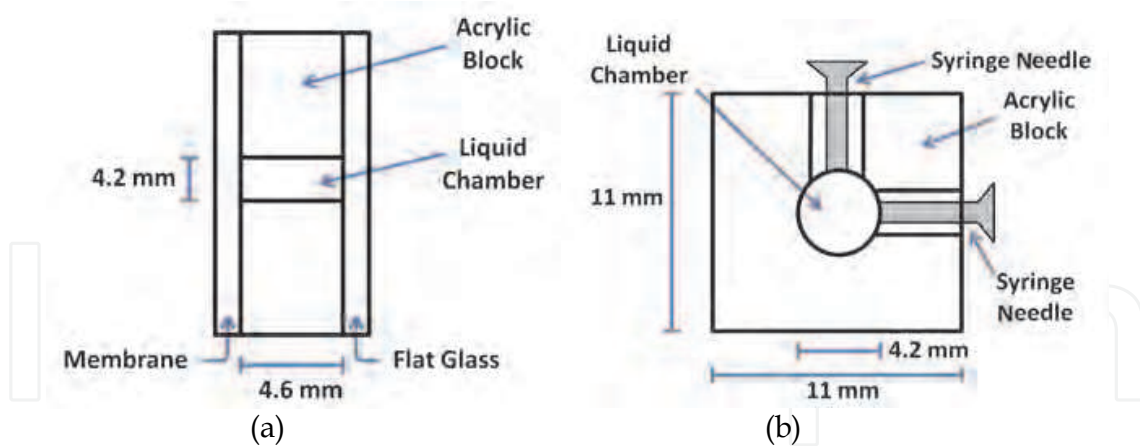

Fig. 9. Side (a) and plain (b) diagrams of a cell. Figure not to scale.



Fig. 10. Photograph of a fabricated cell

Silicone (PDMS) was chosen as the material for the membrane because it is flexible and transparent. Membranes were made by the spinning method. A small amount of silicone and curing agent (10:1) was placed over a flat glass plate that was fixed to the shaft of an electric motor. Then it was spun. Later the plate was leveled and left overnight. Membrane was peeled off the glass and glued to the acrylic block. Membrane thickness ranged between $150\ \mu\text{m}$ to about $220\ \mu\text{m}$.

Membrane roughness is an important parameter in the cell fabrication process. Membranes with large roughness will scatter light and the lens will give blurred images. To avoid large roughness we followed the next method. It is known that when a mixture of silicone and curing agent is placed in contact with a surface the silicone copies perfectly the surface relief. Thus, we chose a polished glass plate for the spinning time. To find out the glass plate roughness we used an Atomic Force Microscope (AFM). In Figure 11a we can see an image ($100\ \mu\text{m} \times 100\ \mu\text{m}$) of the glass plate surface. Here we notice that the surface roughness in an area of about $20\ \mu\text{m} \times 18\ \mu\text{m}$ is $1.15\ \text{nm rms}$. In Fig. 11b is shown a portion ($100\ \mu\text{m} \times 100$

μm) of the silicone surface. The roughness in an area of $16 \mu\text{m} \times 14 \mu\text{m}$ is 0.97 nm rms . This value is close to that shown by the glass plate. With these roughness values we can say that light will be poorly scattered by the membrane surfaces. In Fig.11c is shown a perspective view of some part of the membrane surface.

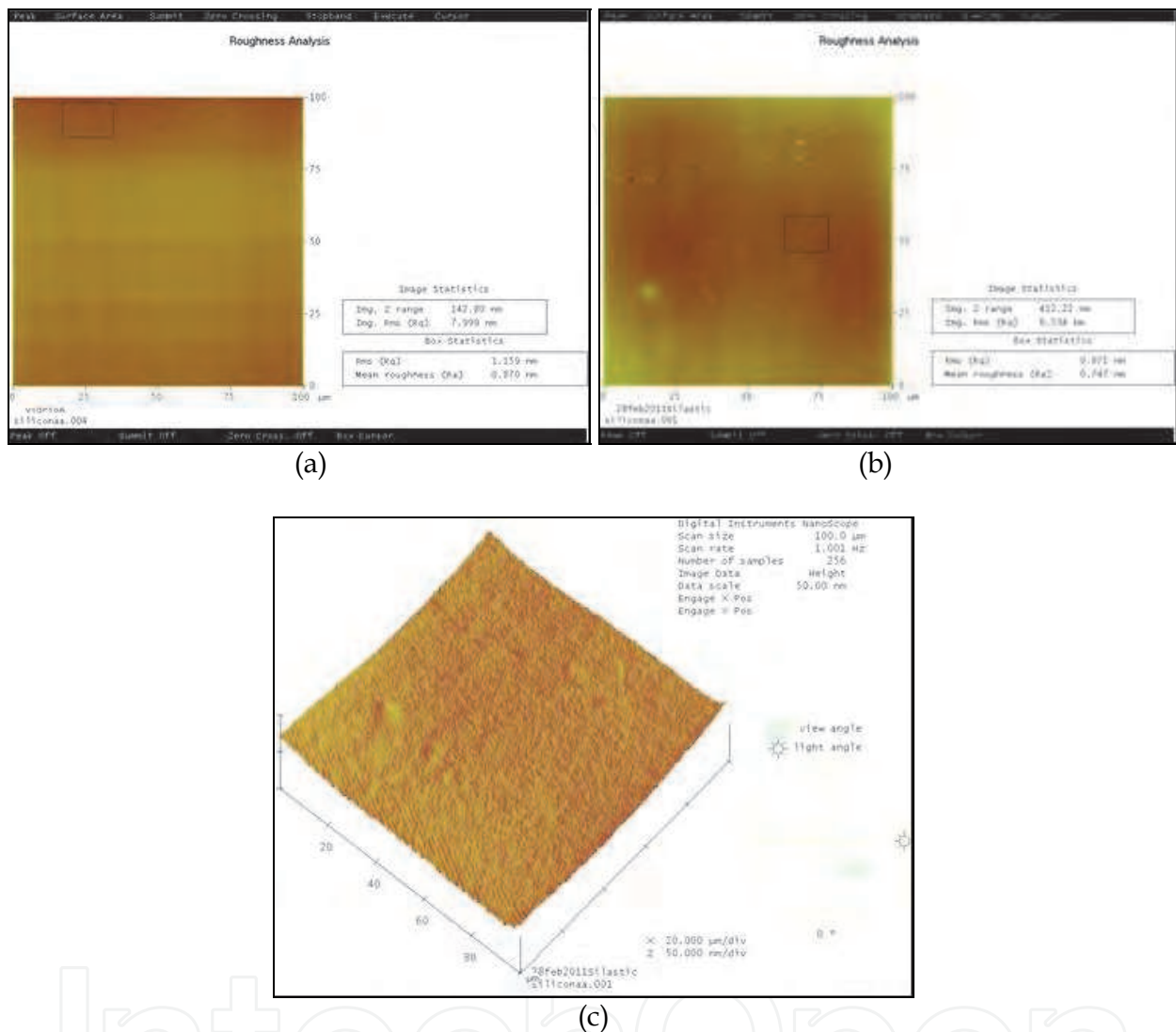

Fig. 11. Images of surfaces given by an AFM. (a) glass plate (b) silicone membrane and (c) Perspective view of a silicone surface.

6. Membranes profiles studies

6.1 Profiles studied with a surface analyzer

Membrane profile changes, caused by positive or negative pressure in the cell, were investigated with a surface analyzer. This instrument has a sharp needle that scans the surface under test. The result is a graph relating the height of the profile as a function of a linear coordinate. In Fig. 12a are shown a series of plots given by the surface analyzer. They show the profiles of a membrane when positive pressures were given. It is noticed that as pressure increases the radius of curvature of the surface decreases. In Fig. 12b are shown the membrane profile curves when the chamber was evacuated.

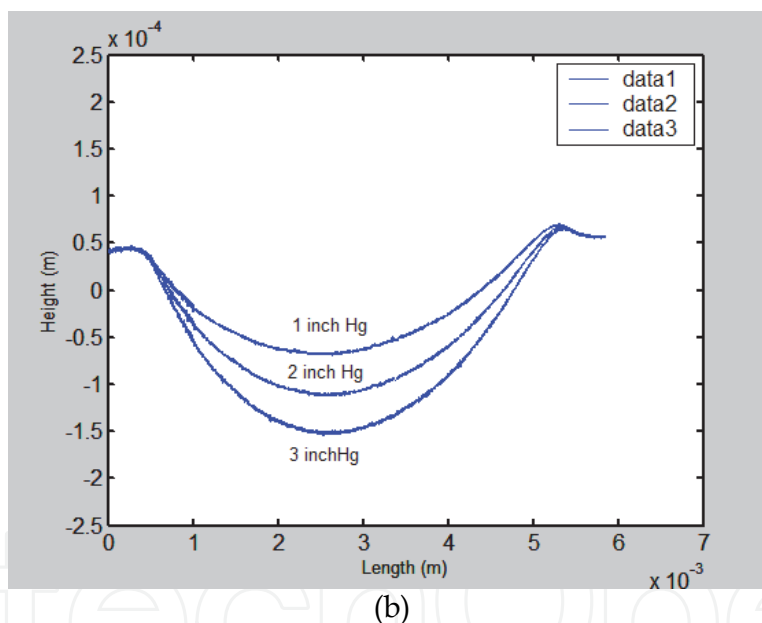
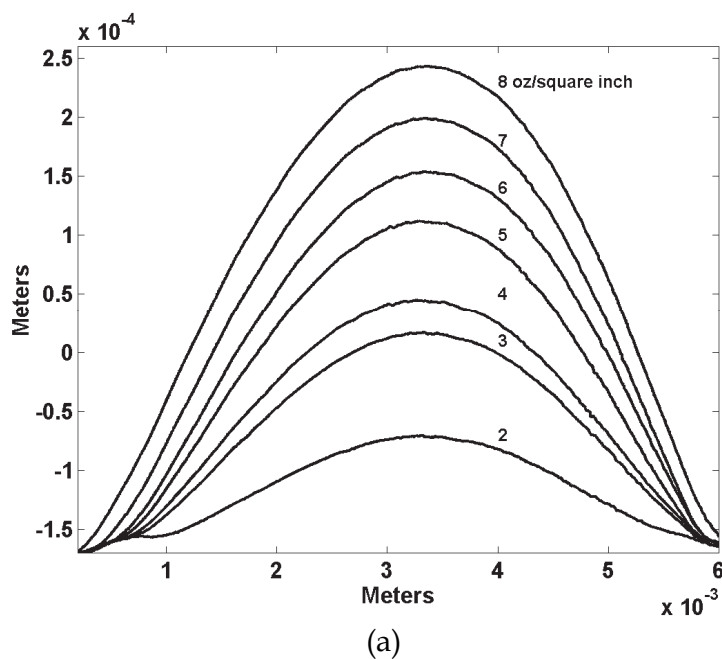

Fig. 12. Cell membranes reliefs measured with a surface analyzer. Parameter is the pressure. In (a) positive pressure was applied. In (b) negative pressure (vacuum) was applied.

6.2 Comparison of membrane profiles with a theoretical circle

In section 4 we have shown that optical designs predict that good liquid lenses can be made with ionic liquids. These designs suppose that the profile of the membranes in the cell is spherical. To find out how close this is to the profile of the membranes, measured with the surface analyzer, to a segment of a circle we followed the method described in the next paragraph.

To determine the deviation of the central part of the profiles from a theoretical circle, such part was extracted from the profiles obtained with the surface analyzer. To do that, given the small dimensions of the lenses and the need to determine the global maxima and

minima of the profiles, it was found convenient to filter the profiles with a Gaussian filter to eliminate quantization noise. Then, the maximum (for positive pressures) or minimum (for negative pressures) of each profile was determined and used as a reference to extract the central part of each profile and two other points (one to the left and another to the right) that were used to calculate the equations of the circumferences that contained those three points of each profile. Once the equation of each circumference was obtained, the corresponding radius was used to determine the deviation of each point of the central part of the profiles from the corresponding theoretical circle. The results of this procedure are shown in figures 13a to 13e. As can be seen, in all cases, for positive and negative pressures, the central parts of the profiles were practically perfect circles. For positive pressures, the maximum deviation from a perfect circle was approximately 0.6 %, while for negative pressures the maximum deviation was close to 0.1 %.

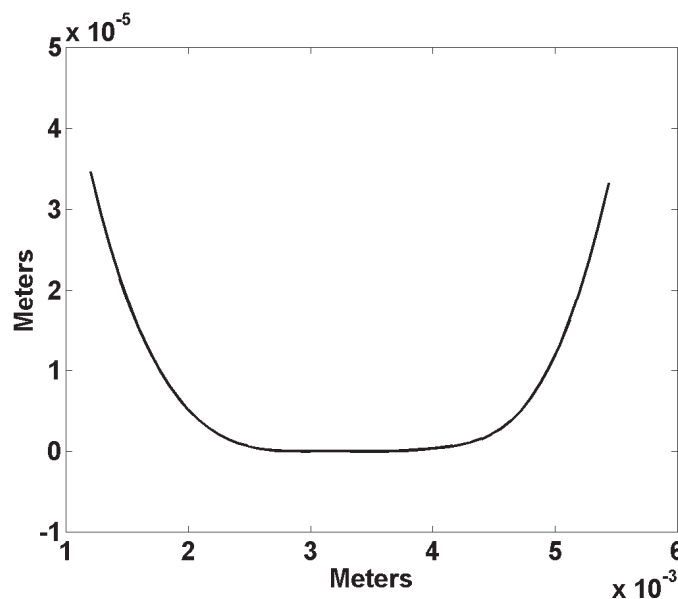

Fig. 13. (a)

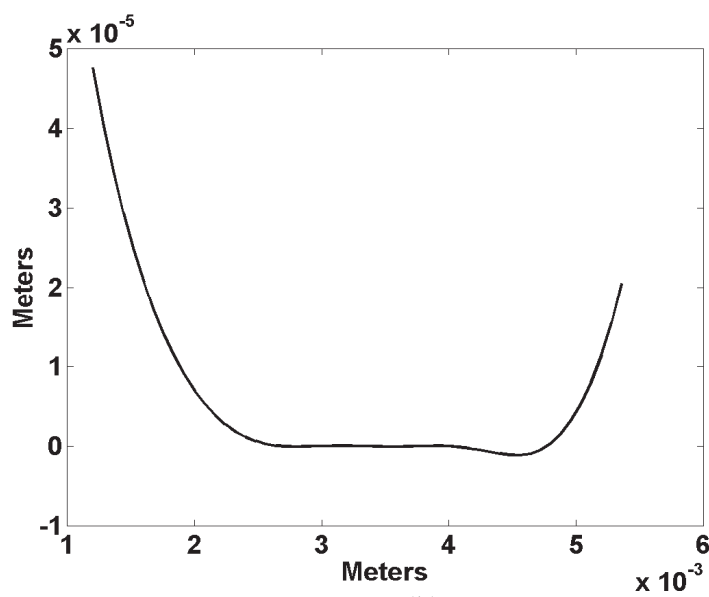

Fig. 13. (b)

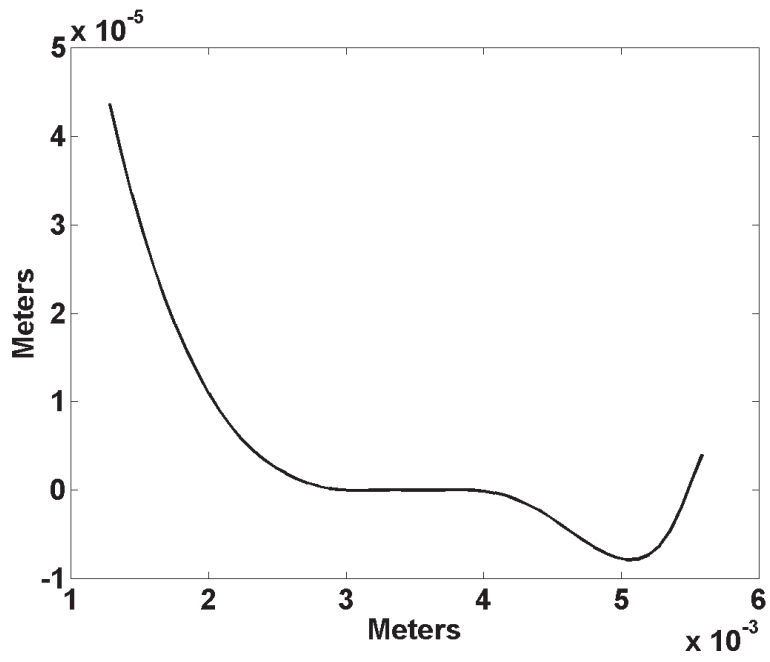

Fig. 13. (c)

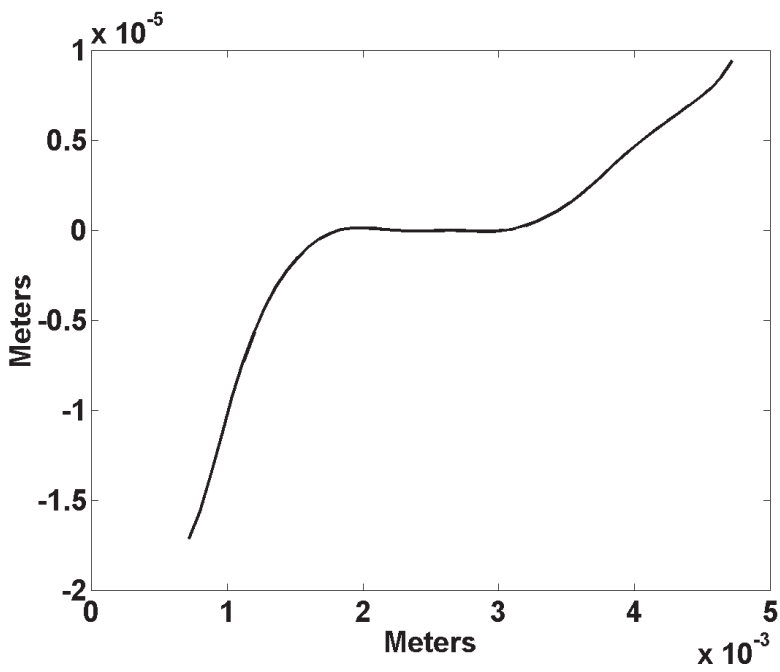

Fig. 13. (d)

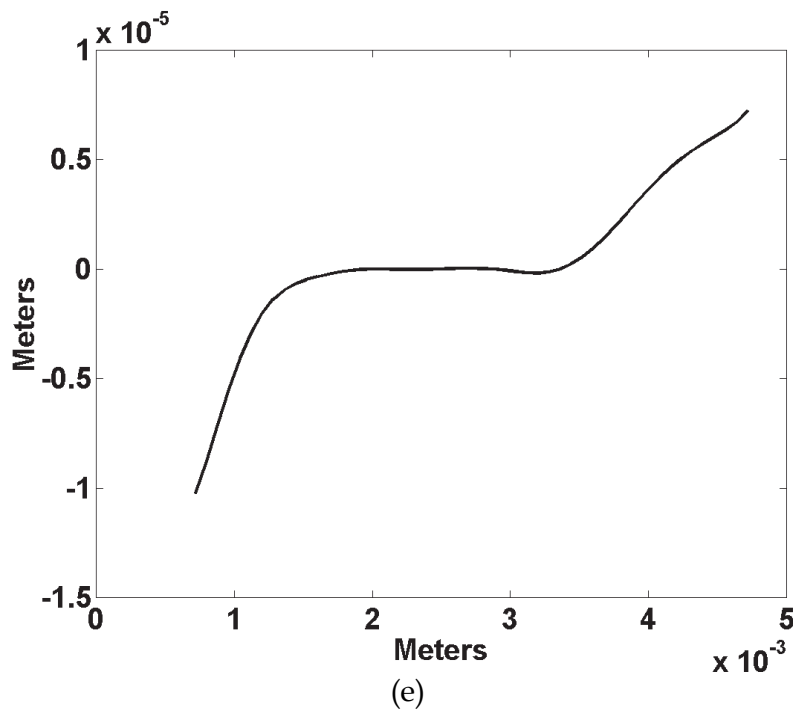

Fig. 13. Deviation of membrane profile with reference to the best-fitting circle. Membrane pressures were the following: (a) 3 inch Hg, (b) 1 inch Hg, (c) 2 oz/inch², (d) 5 oz/inch², (e) 8 oz/inch².

7. Optofluidic lens optical test

7.1 Lens image formation

In the preceding section (6) we have seen that cells membranes bend under pressure. Thus, the cell becomes a lens. The lens membrane can present positive or negative radius of curvature depending whether positive or negative pressure is applied. In Fig. 14a is shown a photograph of the image given by a lens when a positive pressure of 4 oz/inch² was given. Object was a chart printed in a paper placed at about 2 m from the lens. Fig. 14b shows a photograph of the image when a pressure of 2 inch Hg (vacuum) was given.

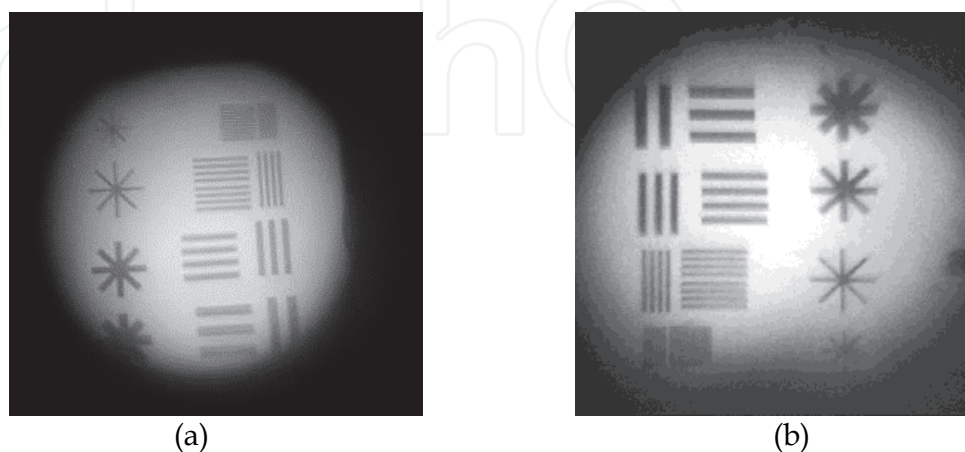

Fig. 14. Images given by a cell when a positive pressure was given, (a), and when negative pressure was given, (b).

7.2 Behavior of membrane radius with pressure

To find the behavior of the radius of curvature of the lenses as a function of pressure (positive or negative) the following method was used. An object consisting of some vertical and horizontal bars was placed about 3 m from the cell. Then pressure was fed into the cell by steps. For each pressure, image given by the lens was found with a microscope. Image position with reference to the lens was measured. If we suppose that the object was far from the lens this distance can be taken as the back focal length of the lens for that pressure. By means of the next formula the membrane radius of curvature was found: $1/f = (n-1) (1/R_1 + 1/R_2 - (n-1)d/R_1 R_2)$, here R_1 and R_2 are the radius of curvature of the glass plate and the membrane, n is the refractive index of the liquid in the cell and d its thickness. Because the glass plate is flat, $R_2 = \infty$. Results of the experiments for a given cell are shown in Fig.15. Here we notice the relation of the pressure in the cell with the focal distance or the membrane radius.

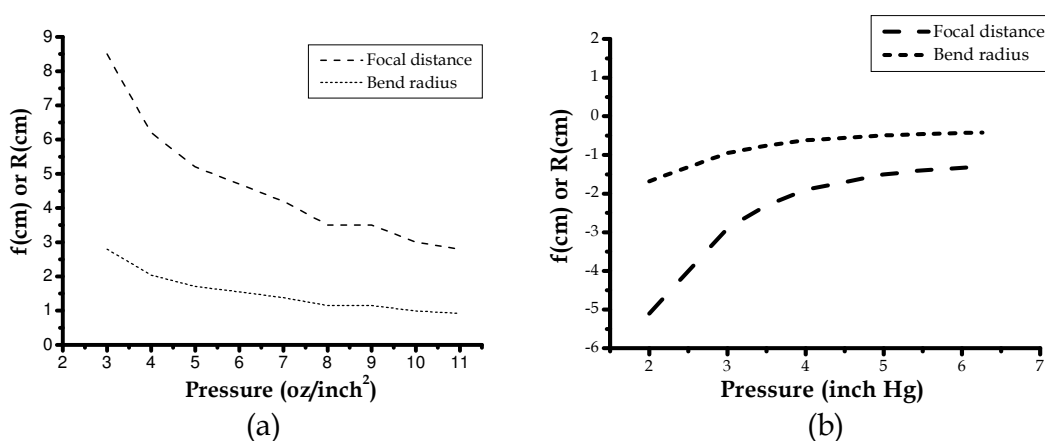

Fig. 15. Behavior of lens focal distance or radius of curvature as a function of pressure. In (a) positive pressures were given. In (b) negative pressures were given.

8. The compound lens

In the preceding sections we have described the fabrication and testing of cells that could compose a compound lens. To test the performance of ionic liquids a doublet formed by two chambers (cells) was fabricated and tested experimentally. The two cells were built containing different ionic liquids: MePyr[HSO₄] and EMIM [TF₂N] for the first and second cells, respectively, see table 3. Each cell is formed by a thin membrane and a thin flat glass. Membrane profile changes with pressure. The two cells are placed (assembled) together by joining the two flat glasses and adding a thin film of immersion oil between the two glasses to decrease internal reflections. The final layout of the compound lens is shown in Fig. 16.

There are some methods to test optical elements (Malacara, 1978). For example those based on the interference of light, formation of images and others. Among the formation of images methods is the star test. Here a small illuminated pinhole is used as object. Its image is formed by the optical system under test and studied with a microscope. Although it is difficult to have quantitative results using this test, for qualitative results requirements are more relaxed. To test the assembled lens we placed an illuminated pinhole (dia. 500 μ m) about 3 m away from the compound lens. Figure 16 shows a diagram of the experimental configuration. Light from the pinhole travels until it reaches the first membrane (A). Then it is refracted and crosses the cell where the MePyr[HSO₄] ionic liquid is. Then it reaches the first

flat glass, the thin immersion liquid film and the second flat glass. After this it enters the second cell, filled with EMIM[TF2] ionic liquid and reaches the second membrane (B). Finally it travels to the place where an image is formed. This image is studied with a microscope. Curvature of each membrane can be changed by means of the pressure, positive or negative, given to each cell.

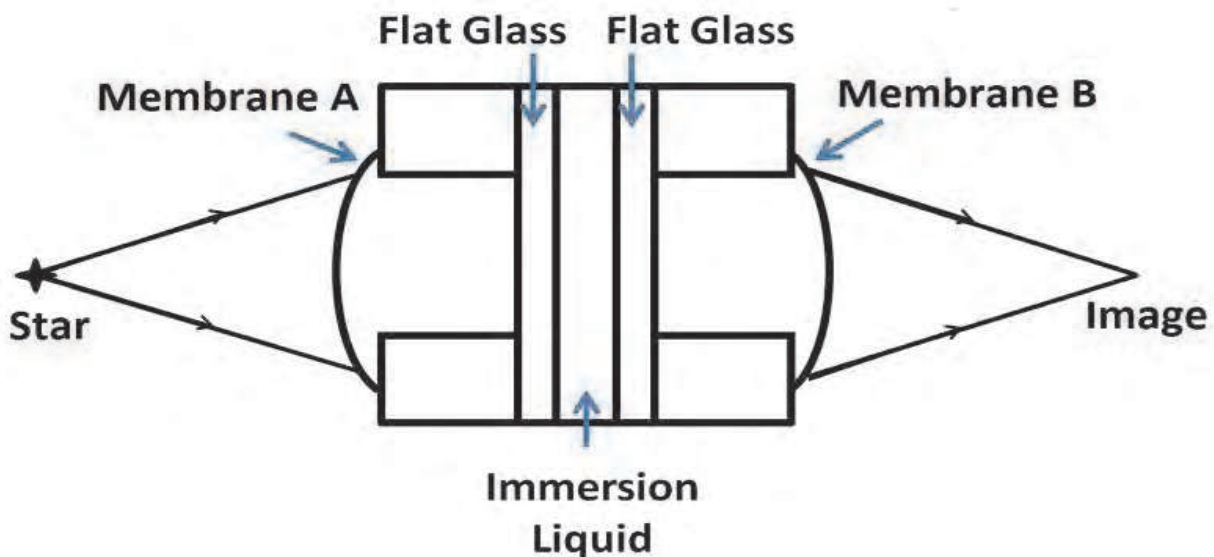

Fig. 16. Diagram showing a compound lens forming an image. Figure not to scale.

In a given experiment we gave to the first cell a pressure of 1 psi. Then we changed the pressure of the second cell by the following values: 3 inch Hg and 2 inch Hg, these values made the second surface (B) of the membrane concave. To have a convex surface we gave the following values: 3 oz/inch², 5 oz/inch², 7 oz/inch². Every time a pressure was given a photograph of the image of the star was taken. These photographs are shown in Figure 17.

Here we can notice that in photographs a) and b) the star image is blurred meaning that aberrations were present. However, for photographs c-f the star image is more rounded meaning aberrations were small.

The star image performance depends on the quality of the lens and the position of the star with respect to the optical axis. By looking at the image of the star shown in figure 17a, we can see that there is astigmatism. This astigmatism may arise from a non spherical surface when changing the pressure of the membrane or may arise from a star which is not located at the optical axis of the doublet. We have seen in section 6.1 that the membranes profile is close to a spherical surface when pressure is applied. Thus, we could assume that the star is not located in the optical axis. Let us assume that the star is located at 10° semifield of view. We know that the first cell had a pressure of 1 psi. Thus it had a radius $R = 9$ mm. Radius of the second membrane was varied between -4 mm and -20 mm for positive pressure, and between 4 mm and 20 mm for negative pressures. Seidel aberration wavefront (Kidger, 2002) was calculated and its behavior is shown in Figure 18. Fig 18a shows behavior when R is in the range from -4 mm to -20 mm. Fig. 18b when R goes from 4 mm to 20 mm.

From Figure 18 we can observe that the aberration decreases when the radius of curvature of the second membrane increases or tends to infinity. In Figure 18(a) we can see that the best image is obtained for a pressure of 1psi in the first cell and 0 inch Hg for the second cell. This last value means the membrane is a plane surface. For negative pressure, Figure 18(b),

the aberration difference between $R=9\text{mm}$ and $R=20\text{mm}$ is approximately 0.027mm which is larger than the aberration difference for positive pressure between $R=-9\text{mm}$ and $R=-20\text{mm}$, given approximately by 0.002mm , see Figure 18(a). This result qualitatively agrees with the star images shown in Figure 17 where a larger image degradation is observed when negative pressure is applied to the second cell.

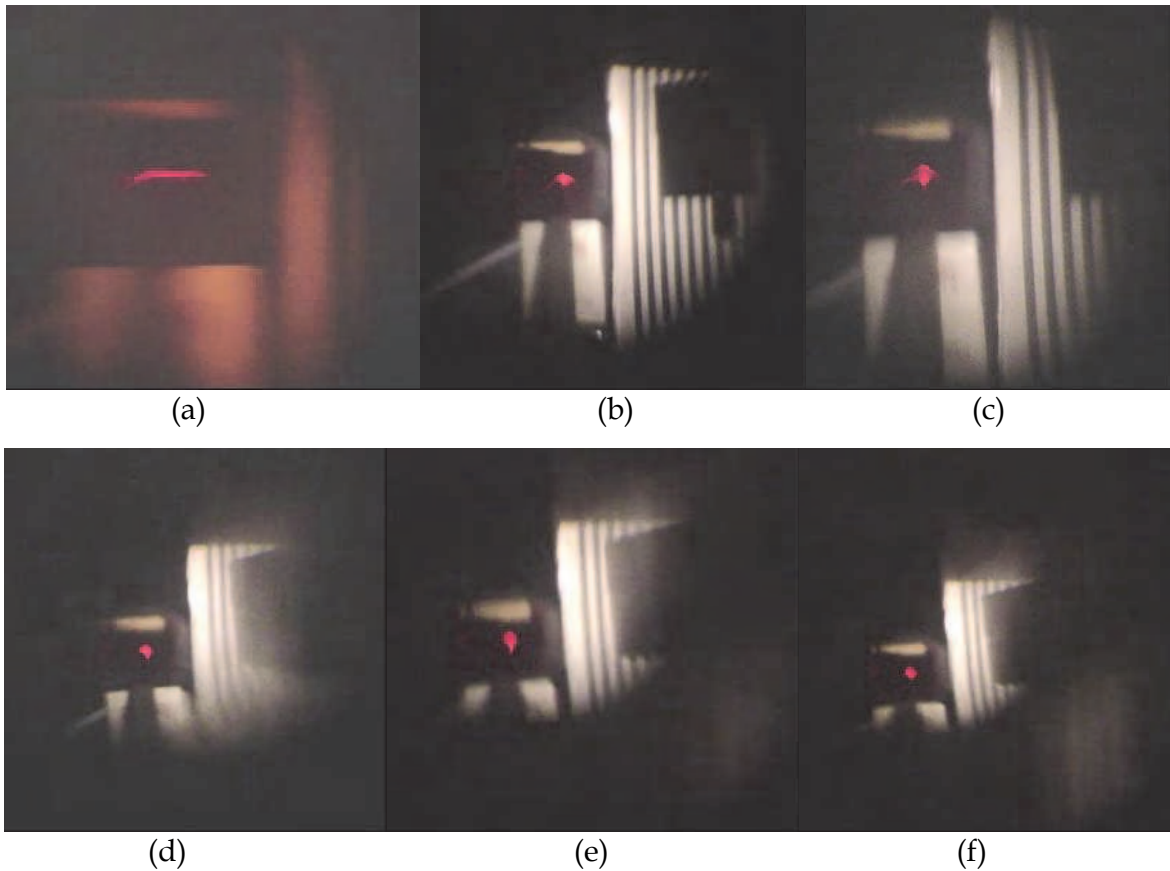

Fig. 17. Photographs showing the images of a pinhole (star), placed at 3 m, given by a two-cell compound lens under different negative and positive pressure. First cell had a pressure of 1 oz/inch^2 . Second cell had different pressures: (a) 3 inch Hg, (b) 2 inch Hg, (c) zero pressure, (d) 3 oz/inch^2 , (e) 5 oz/inch^2 , (f) 7 oz/inch^2 .

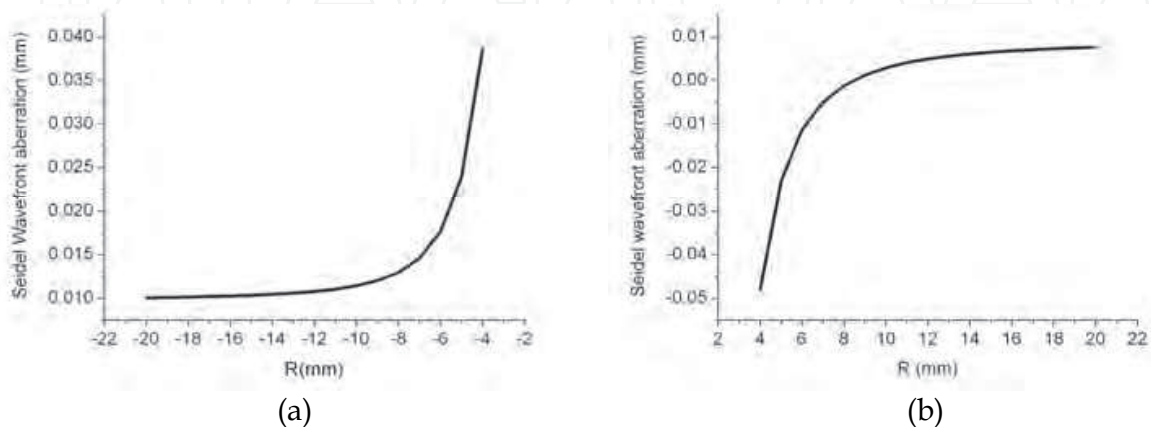

Fig. 18. Wavefront aberration vs. Radii of curvature.

The two-cell compound lens was also tested to find the possibility to form images of nearby objects. An USAF test chart was placed about 2 cm away from the cell. Then a pressure of 1 psi was given to the first cell and a pressure of 11 oz/inch² was given to the second cell. Image was studied with a microscope and is seen in Fig. 19. We can notice that element 3 in group 5 of the test chart can be seen. This means that about 40 lp/mm can be resolved.

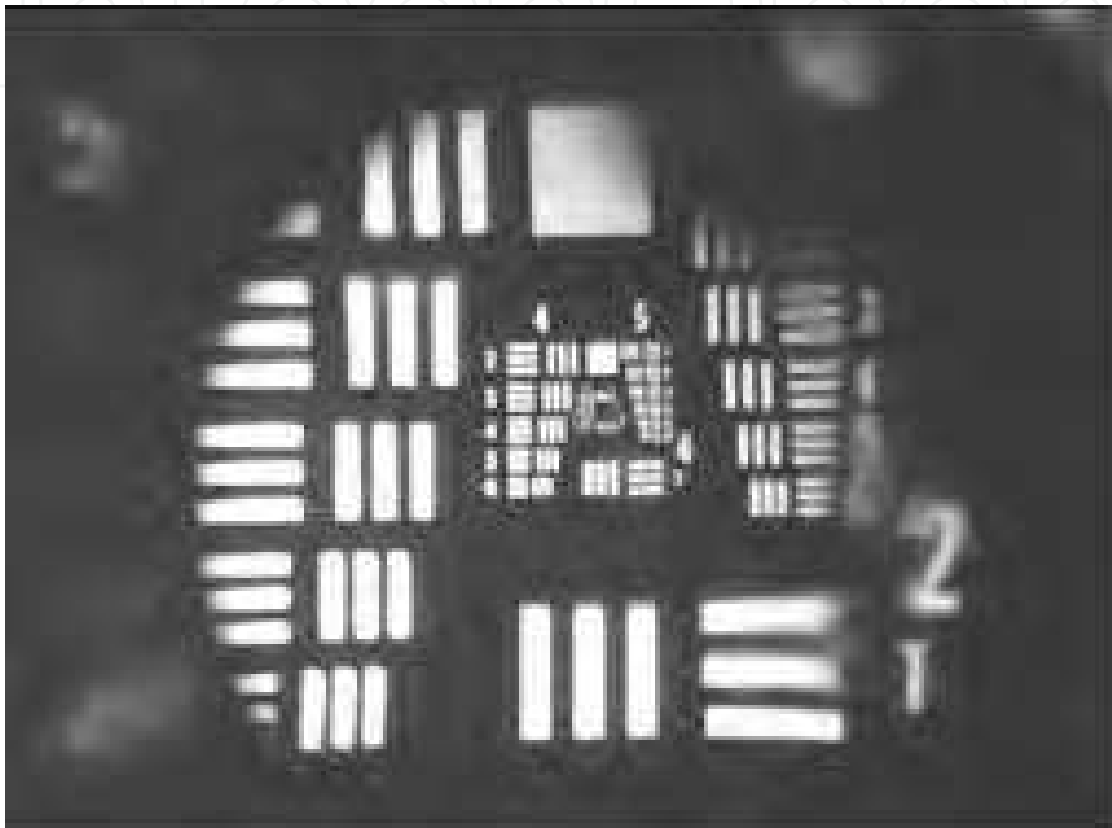

Fig. 19. Image of an USAF test target placed about 2 cm from the membranes cell. Element 3 group 5 can be resolved (40 lp/mm).

9. Conclusions and comments

Some ionic liquids have been studied with a spectroscope and a plot relating n_D vs Abbe value has been found. This plot could be used as a basis to choose some ionic liquids for an optical application.

In section 2 we have mentioned that there is a large number of combinations of cations and anions that could produce limitless different ionic liquids. Thus, ideally we can adapt a specific set of ionic liquids to an optofluidic optical system that has a specific task. However, more chemical and optical studies of ionic liquids should be done. With these new studies we will have more points in the n_D - Abbe value diagram and the optical designer will have more freedom to design an optical system.

We have described the characterization studies made to the membranes. Parameters like roughness and profiles under pressure have been exposed. A study of the membrane profiles tell us that their deviation from a theoretical circle is small. Also it was shown that cells were able to form images. Besides this a two-cell compound lens was assembled. This compound lens gave images with different sizes when the pressure on one cell was changed.

In section 4, we have shown an optical design study of a 3 cell compound lens. Liquids considered were ionic liquids. From the theoretical point of view (diffraction limited behavior) optical behavior of this three-cell lens is good. However, the fabrication of such a three cell compound lens needs the development of more accurate fabrication methods. Probably with MEMS technology the three cell compound lens could be made. With our low-technology method, comprising acrylic cells, just a two-cell compound lens with diameters of some millimeters can be done.

10. Acknowledgments

We thank Antonio Martinez Richa and Karla A. Barrera Rivera for supplying the ionic liquids. Also we thank Octavio Pompa Carrera for helpful discussions.

11. References

- Aniruddha P. & Anunay S. (2006) Optical absorption and fluorescence studies on imidazolium ionic liquids comprising the bis(trifluoromethanesulphonyl)imide anion. *J. Chem Sci.*, vol. 118, No.4, (July 2006), pp. 335-340, ISSN 0253-4134
- Borra E., Seddiki O., Angel R., Eisenstein D., Hickson P., Seddon K.R. & Worden S.P. (2007). Deposition of metal films on an ionic liquid as a basis for a lunar telescope. *Nature*, Vol. 447, pp. 979-981, ISSN 0028-0836
- Brennecke J.F. & Maginn E.J. (2001). Ionic Liquids: Innovative Fluids for Chemical Processing. *AIChE Journal*, vol. 47, No.11, pp. 2384-2389, ISSN 0001-1541
- Calixto S., Sanchez-Morales M.E., Sánchez-Marín F.J., Rosete-Aguilar M., Martínez-Richa A., & Barrera-Rivera K.A. (2009). Optofluidic Variable Focus Lenses. *Appl. Opt.*, Vol. 48, pp. 2308-2314, ISSN 0003-6935
- Cargille Laboratories, Specifications of Cargille *Optical Liquids*, www.cargille.com
- Erickson D., Yang C. & Psaltis D. (2008). Optofluidics emerges from the laboratory, *Photonics spectra*, Vol. 42, pp. 74-79, ISSN 0731-1230
- Freemantle M. (2007). New frontiers for ionic liquids. *Chemical & Engineering News*, Science and Technology Vol 85, pp. 23-26 ISSN 0009-2347
- Hu S., Ren H., Lin Y.J., Moharam M.G.J., Wu S.T., & Tabiryan N. (2009). Adaptive liquid lens actuated by photo-polymer. *Opt. Express*, Vol. 17, pp. 17590-17595, ISSN 1094-4087
- Kidger M.J.(2002), "Fundamental Optical Design", SPIE-The International Society for Optical Engineering.
- Kuiper S. & Hendriks B.H.W. (2004). Variable focus liquid lens for miniature cameras. *Appl. Phy. Lett.*, Vol. 85, pp. 1128-1130 ISSN 0003-6951

- Lin, H. Oliveira P. & Veith M. (2011). Application of ionic liquids in photopolymerizable holographic materials. *Optical Materials*, 33, (January 2011), pp. 759-762, ISSN 0925-3467.
- Malacara, D. (1978) *Optical Shop testing*, Wiley, ISBN 0-471-01973-9, New York.
- Malacara D. & Thompson B.J. (2001). *Handbook of Optical Engineering*, Marcel Dekker, ISBN: 0-8247-9960-7, New York.
- Mills N.J. (1986). *Plastics Microstructure, Properties and Application*, Edward Arnol
- Pham T.P.T., Cho C.W. & Yun Y.S. (2010). Environmental fate toxicity of ionic liquids: A review. *Water research*, Vol. 44, pp. 352-372, ISSN 0043-1354
- Reichelt S. & Zappe H. (2007). Design of spherically corrected, achromatic variable-focus liquid lenses. *Opt. Express*, Vol. 15, pp. 14146-14154, ISSN 1094-4087
- Ren H. & Wu S-T. (2007). Variable focus liquid lens. *Opt. Express*, Vol 15, pp. 5931- 5936, , ISSN 1094-4087
- Romero A. (2008) Ionic liquids to ambient temperature: a new one means for the chemical reactions. *Rev. R. Acad. Cienc. Exact. Fís. Nat.*, 102, No.1, pp. 79-90, ISSN 1578-7303
- Sai F.T., Cho S.H., Lo Y.H.H & Vasko B. (2008). Miniaturized universal device using fluidic lens. *Opt. Lett.*, Vol. 33, pp. 291-293, ISSN 0146-9592
- Simonds H.R. & Church J.M. (1964). *Concise Guide to Plastics*, Reinhold Publishing Corporation
- Smith W, (1966) *Modern Optical Engineering*, McGraw Hill, ISBN 07-058690-x, New York.
- Souza R. F. Alencar M., Meneghetti M. & Hickmann J. (2008). Nonlocal optical nonlinearity of ionic liquids. *J. Phys. Condens. Matter*, 20, (March 2008), pp. 1-5, ISSN 0953-8984
- Ueki T. & Watanabe M. (2008). Macromolecules in Ionic Liquids: Progress, Challenges, and Opportunities. *Macromolecules*, 41, No.11, (June 2008), pp. 3739-3749, ISSN 0024-9297
- Wasserscheid P. & Keim W. (2000). Ionic Liquids-New Solutions for Transition Metal Catalysis. *Angew. Chem. Int. Ed.*, 39, pp. 3772-3789, ISSN 1433-7851
- Werber A. & Zappe H. (2005). Tunable microfluidic lens. *Applied Optics*, Vol. 44, pp. 3238-3245, ISSN 0003-6935
- Weyershausen B. & Lehmann K. (2004). Industrial application of ionic liquids as performance additives. *Green. Chem.*, Vol. 7, (November 2004), pp. 15-19, ISSN 1463-9262
- Wilkes J. S. (2002). A short history of ionic liquids-from molten salts to neoteric solvents. *Green Chemistry*, 4, (March 2002), pp. 73-80, ISSN 1463-9262
- Xu S., Liu Y., Ren H. & Wu S.T. (2010). A novel adaptive mechanical-wetting lens for visible and near infrared. *Opt. Express*, Vol. 18, pp. 12430-12435, ISSN 1094-4087
- Yu H.B., Zhou G.Y., Chau F.S., Lee F.W., Wang S.H., & Leung H.M. (2009). A liquid filled tunable double-focus microlens. *Opt. Express*, Vol. 17, pp. 4782-4790, ISSN 1094-4087
- Zeng X.F. & Jiang H. (2008). Tunable liquid microlens actuated by infrared light- responsive hydrogel. *Appl. Phy. Lett.*, Vol 93, pp. 151101, ISSN 0003-6951
- Zhang, W, Aljasen K., Zappe H., Seifert A, (2011) Completely integrated, thermo-pneumatically tunable microlens, *Optics Express*, Vol. 3, 247 - 2358, ISSN 1094-4087.

www.us.schott.com

www.oharacorp.com/index.html

IntechOpen

IntechOpen



Applications of Ionic Liquids in Science and Technology

Edited by Prof. Scott Handy

ISBN 978-953-307-605-8

Hard cover, 516 pages

Publisher InTech

Published online 22, September, 2011

Published in print edition September, 2011

This volume, of a two volume set on ionic liquids, focuses on the applications of ionic liquids in a growing range of areas. Throughout the 1990s, it seemed that most of the attention in the area of ionic liquids applications was directed toward their use as solvents for organic and transition-metal-catalyzed reactions. Certainly, this interest continues on to the present date, but the most innovative uses of ionic liquids span a much more diverse field than just synthesis. Some of the main topics of coverage include the application of RTILs in various electronic applications (batteries, capacitors, and light-emitting materials), polymers (synthesis and functionalization), nanomaterials (synthesis and stabilization), and separations. More unusual applications can be noted in the fields of biomass utilization, spectroscopy, optics, lubricants, fuels, and refrigerants. It is hoped that the diversity of this volume will serve as an inspiration for even further advances in the use of RTILs.

How to reference

In order to correctly reference this scholarly work, feel free to copy and paste the following:

Sergio Calixto, Martha Rosete-Aguilar, Francisco J. Sanchez-Marin, Olga L. Torres-Rocha, E. Militza Martinez Prado and Margarita Calixto-Solano (2011). Optofluidic Compound Lenses Made with Ionic Liquids, Applications of Ionic Liquids in Science and Technology, Prof. Scott Handy (Ed.), ISBN: 978-953-307-605-8, InTech, Available from: <http://www.intechopen.com/books/applications-of-ionic-liquids-in-science-and-technology/optofluidic-compound-lenses-made-with-ionic-liquids>

INTECH
open science | open minds

InTech Europe

University Campus STeP Ri
Slavka Krautzeka 83/A
51000 Rijeka, Croatia
Phone: +385 (51) 770 447
Fax: +385 (51) 686 166
www.intechopen.com

InTech China

Unit 405, Office Block, Hotel Equatorial Shanghai
No.65, Yan An Road (West), Shanghai, 200040, China
中国上海市延安西路65号上海国际贵都大饭店办公楼405单元
Phone: +86-21-62489820
Fax: +86-21-62489821

© 2011 The Author(s). Licensee IntechOpen. This chapter is distributed under the terms of the [Creative Commons Attribution-NonCommercial-ShareAlike-3.0 License](https://creativecommons.org/licenses/by-nc-sa/3.0/), which permits use, distribution and reproduction for non-commercial purposes, provided the original is properly cited and derivative works building on this content are distributed under the same license.

IntechOpen

IntechOpen