

We are IntechOpen, the world's leading publisher of Open Access books Built by scientists, for scientists

5,300

Open access books available

130,000

International authors and editors

155M

Downloads

Our authors are among the

154

Countries delivered to

TOP 1%

most cited scientists

12.2%

Contributors from top 500 universities



WEB OF SCIENCE™

Selection of our books indexed in the Book Citation Index
in Web of Science™ Core Collection (BKCI)

Interested in publishing with us?
Contact book.department@intechopen.com

Numbers displayed above are based on latest data collected.
For more information visit www.intechopen.com



Study on the Energy Efficiency of Soft Starting of an Induction Motor with Torque Control

José de Oliveira¹, Ademir Nied¹,
Mário Henrique Farias Santos¹ and Rogério Pinho Dias²

¹State University of Santa Catarina

²WEG Equipamentos Elétricos S.A.
Brazil

1. Introduction

Energy plays an important role in the paradigm of sustainable development. Nowadays, energy consumption is one of the key factors to measure the development of a country. According to the IEO2010 Reference case report (U.S. Energy Information Administration, 2010), world energy consumption will increase by 1.4 percent per year, from 495 quadrillion Btu in 2007 to 739 quadrillion Btu in 2035, as shown in Fig. 1.

The increasing of global energy consumption and the great concern to preserve the environment in the face of the current scenario which includes global warming, the greenhouse effect and the depletion of natural resources, aroused the awareness of governments, along with non-governmental organizations, to accelerate adopting policies and practices that will promote efficient use of energy (IEEE-USA, 2010).

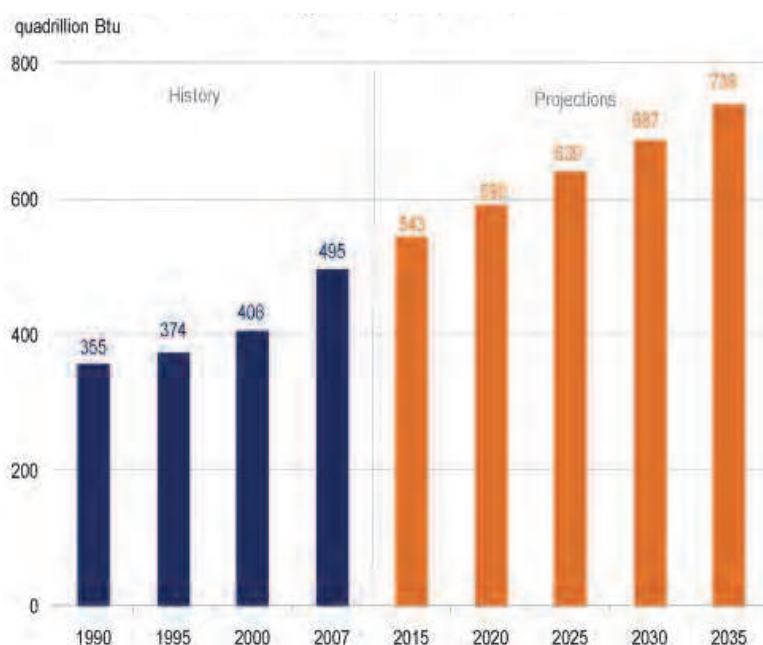

Fig. 1. World Marketed Energy Consumption, 1990-2035 (U.S. Energy Information Administration, 2010).

According to the WEC (World Energy Council, 2009), in industrialized countries three main sectors are responsible for three quarters of electricity consumption: electric motors, 45%, lighting, about 15%, and home appliances and consumer electronics, also around 15%. Global energy consumption of electric motors is around 9000 TWh per year. These data show the impact that electric motors produce on electrical energy consumption. Therefore, the manufacturers in this sector are investing heavily in the energy efficiency of their products.

From the establishment of the vector control approach for field-oriented control and the evolution of microelectronics and power electronics, the induction motor has come to occupy a prominent position among variable-speed electric drives (Leonhard, 1988).

The same technological developments that allowed the use of induction motors in variable speed drives to replace DC motors also enabled the development of soft starting electronic devices that allow better control of the induction motor starting and stopping process. This equipment, beyond controlling the starting current value suited to the demands of the energy utilities, allows better control of motor acceleration and deceleration (Bruce et al., 1984), (Colleran & Rogers, 1983), (Nevelsteen & Aragon, 1989).

In this chapter, the authors present a study of energy efficiency obtained by using a soft starter to start a 300 HP induction motor. Experimental results are shown comparing the energy efficiency of a soft starter using two different control techniques: current control and torque control.

2. Induction motor starting characteristics using a soft starter

Soft starters are devices that use silicon-controlled rectifiers (SCRs) for providing a low voltage to the motor from a grid voltage and fixed frequency. The value of the voltage applied to the motor can be varied over a wide range, from very small values up to the value of the grid by controlling the firing angle of the SCRs.

The consequences of this reduction in the value of the applied voltage are the decrease in electric current drawn from the grid and the reduction of the torque developed during the process of starting or stopping. Fig. 2 shows a basic schematic diagram of a soft starter with anti-parallel SCRs and the feedback from current and voltage.

The interface circuit is responsible for acquiring and processing measured voltage and current signals, which are processed digitally by the control program. The command signals from the digital processing are then sent by control to a firing circuit, responsible for driving the SCRs and consequently, the induction motor.

Soft start devices provide two major benefits in their application (Gritter et al., 2000):

- Less stress on the motor mechanically coupled to the load due to the reduced amplitude of the pulse of the starting torque motor;
- Smoothing the motor acceleration and reducing the demand for energy flow in electric power systems due to the reduction of peak current when starting the motor.

Usually two techniques are employed to control the soft starter: voltage-ramp and current control.

The voltage-ramp technique is performed through a firing-angle ramp of SCRs. Thus, although better than the non-electronic starter methods, it does not guarantee a more effective control over current and acceleration during starting process and over deceleration during stopping process.

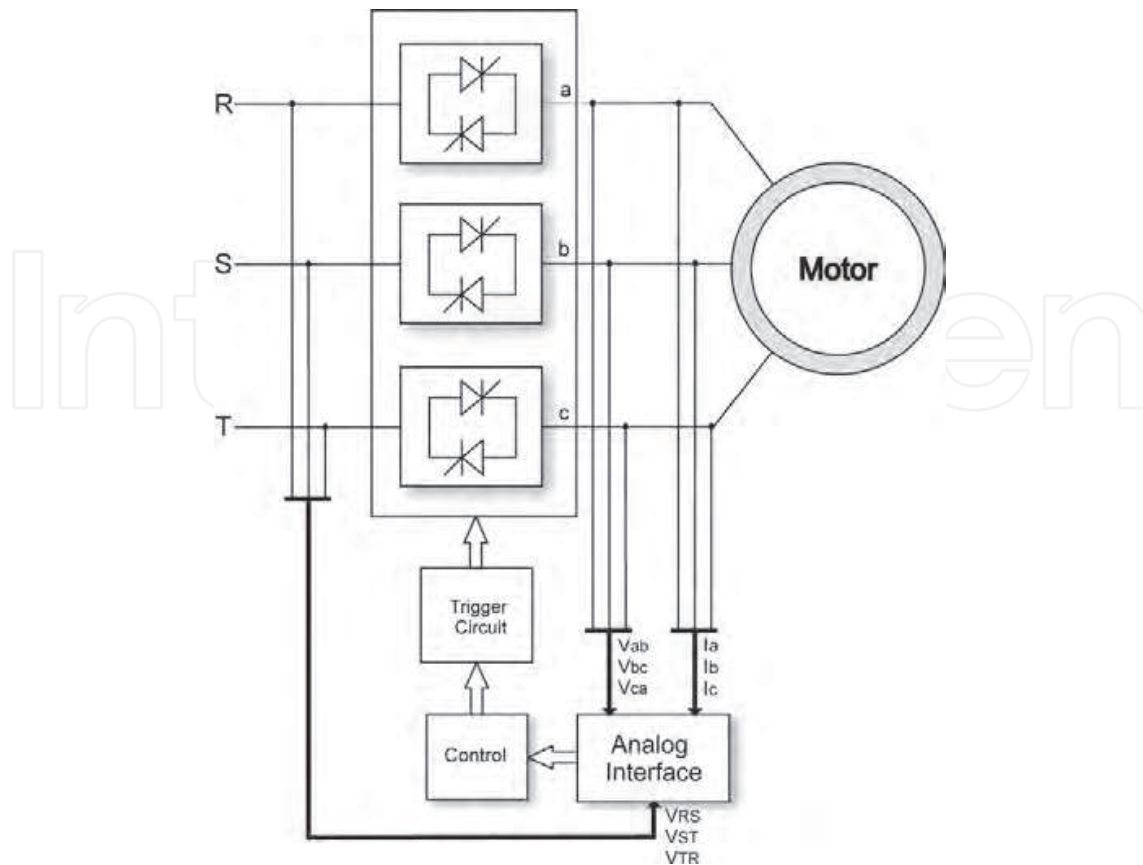

Fig. 2. Basic diagram of a soft-starter.

The angle ramp, shown in Fig. 3, is called voltage-ramp, due to the fact that the majority of commercial soft starters do not possess voltage feedback applied to the motor, i.e., the induction motor voltage is controlled through a firing angle ramp in an open loop. This technique is simple, and it is used in low-cost commercial soft starters. It will always produce a starting quadratic torque curve that can be applied to small hydraulic pumps and small fans.

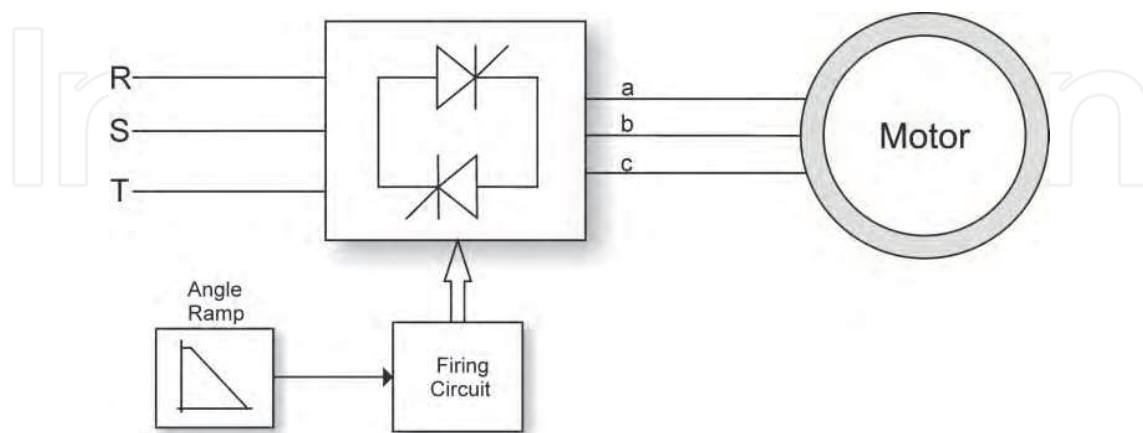

Fig. 3. Basic block diagram of the voltage-ramp technique.

Considering the starting motor using the voltage-ramp technique, the waveforms of electromagnetic torque and motor current are shown in Fig. 4.

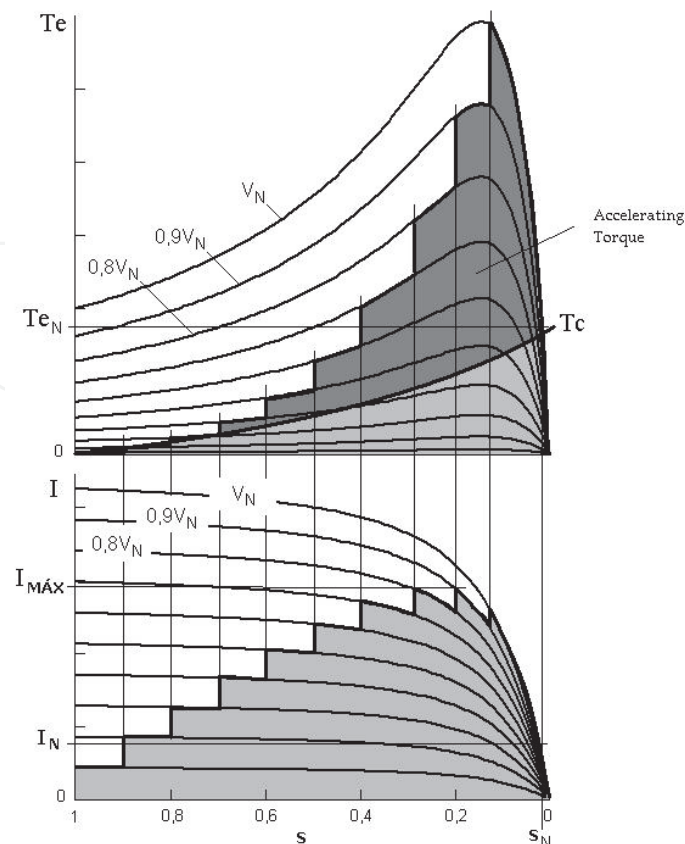

Fig. 4. Electromagnetic torque and motor current waveforms using the voltage-ramp technique.

Figure 4 illustrates the motor starting using the voltage-ramp technique with a load which has a quadratic torque curve (T_C). As can be verified, for each interval of 10% of synchronous motor speed, 10% of rated motor voltage is added. Still, the variation of electromagnetic torque (T_e) and motor current (I) due to the variation of stator voltage can be clearly seen. Using this type of ramp-voltage technique, the electromagnetic torque produced by the motor is always quadratic (Palma, 1999).

On the other hand, the current control technique controls the current at a constant value and one that is appropriate for the requirements for starting, solving the problem of the high inrush current transient inherent in induction motors with direct starting. However, it does not satisfactorily solve the issue of stress on mechanical coupling with the load. It also can induce a more pronounced acceleration during the final period of the starting process (Zenginobuz et al., 2001).

Fig. 5 shows the diagram of the current control technique. The three current signals are used to calculate the true RMS current value. This current value (I_{RMS}) is used by the controller as the feedback signal in order to keep the current constant at the pre-set value (I_{REF}) during the motor starting process.

This technique will always generate an almost constant starting torque curve that can be applied to a constant load torque. This technique has the advantage of adapting the induction motor starting within the capabilities of the supplying utility.

For an example of a load with quadratic torque characteristics (T_C), Fig. 6 presents the induction motor electromagnetic torque and current waveforms considering the motor

starting using the current control technique, i.e., with current limitation. The current is kept constant at a predefined value during the whole motor starting time, but the current control can only operate under a rated voltage variation of 10 %.

From Fig. 6, it can be noted that through the current limitation (I_{MAX}) the initial electromagnetic torque developed (T_e) varies very little until 70% of the synchronous motor speed. However, during the final period of the motor starting process, one can verify the existence of a torque pulse, in which, for certain kinds of loads, an abrupt acceleration can be generated (Palma, 1999). This technique also has problems with the starting of non-constant loads, such quadratic loads, linear loads and loads with high resistive torque, because it is difficult to predict the torque profile produced in this type of technique.

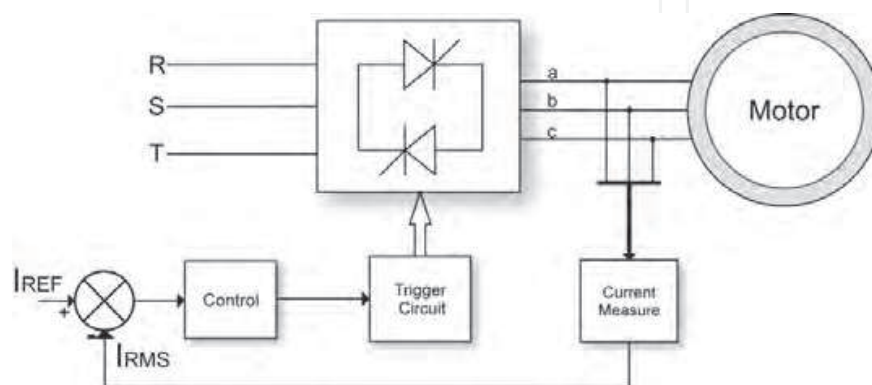

Fig. 5. Basic block diagram of the current control technique.

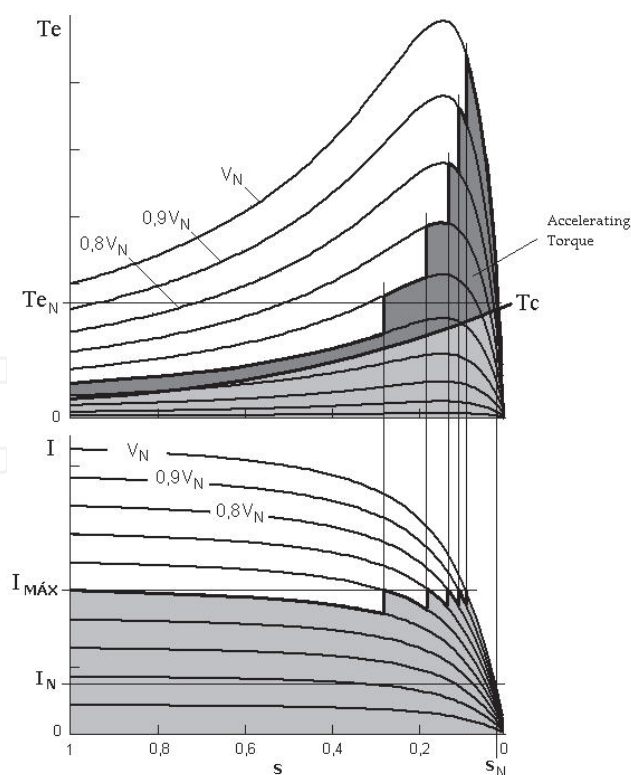

Fig. 6. Electromagnetic torque and motor current waveforms using the current control technique.

From the electromagnetic torque characteristics shown in Figs. 4 and 6, it is noted that, using the voltage-ramp technique or the current control technique for limiting current, in both cases a torque profile is obtained that does not adequately match with the load profile. Although these motor starting techniques can provide an almost constant torque during the beginning of the starting process, one can verify the existence of a torque pulse, in which for certain kinds of loads, an abrupt acceleration can be generated.

Therefore, it seems that a good solution to solve the existence of a torque pulse is to directly control the electromagnetic torque developed by the induction motor during the starting and stopping processes, adapting it to the torque profile of the driven load.

3. Torque control technique

The difficulties related to implementing a soft-starter with torque control are more related to limitations resulting from hardware (inability of the drive frequency variation due to SCRs) than the theoretical knowledge associated with the control design.

Figure 7 shows the diagram of the torque control technique for limiting the electromagnetic torque of the motor (Nied et al., 2008). From the motor voltages and currents measurements, the flux estimation is calculated, and from that, one obtains the estimated electromagnetic torque. The error signal generated from the difference between the torque reference signal and the estimated torque signal is applied to a controller, which generates the appropriate signal to the soft-starter trigger circuit.

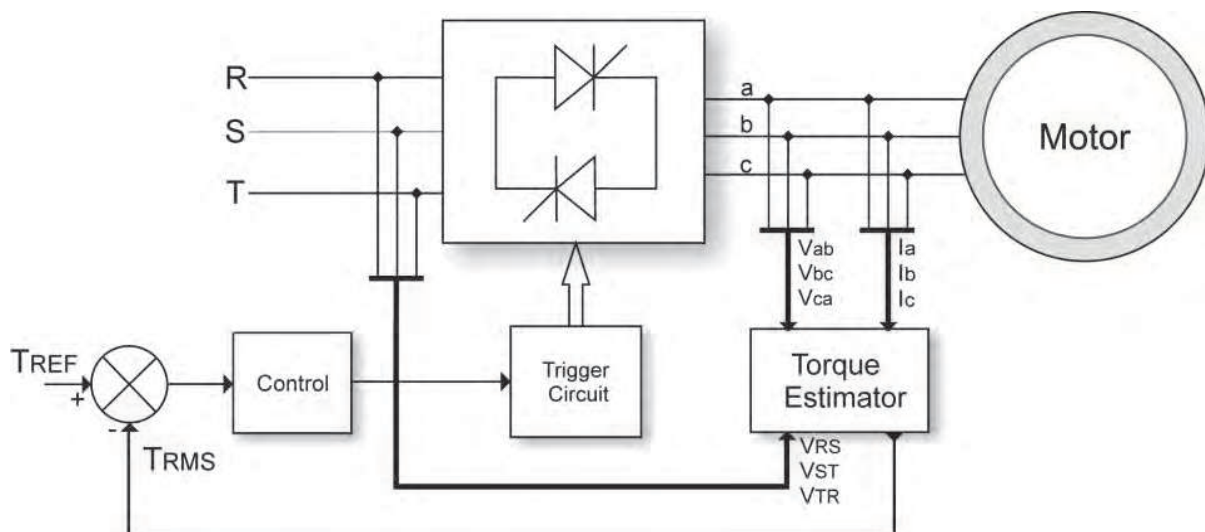

Fig. 7. Basic block diagram of the torque control technique.

In Equations (1-3), \bar{E} is the back electromotive force, R_s is the motor stator resistance, \bar{V}_s and \bar{I}_s are, respectively, the measured stator supply voltages and currents in the $\alpha - \beta$ stationary reference frame:

$$\bar{E} = \bar{V}_s - \bar{I}_s \cdot R_s \quad (1)$$

$$\bar{V}_s = \begin{bmatrix} V_{\alpha s} \\ V_{\beta s} \end{bmatrix} \quad (2)$$

$$\bar{I}_S = \begin{bmatrix} I_{\alpha S} \\ I_{\beta S} \end{bmatrix}. \quad (3)$$

The stator flux is estimated through the integration of the back electromotive force as described by the following equations:

$$\bar{\lambda}_S = \int \bar{V}_S - \bar{I}_S \cdot R_S dt \quad (4)$$

$$\lambda_{\alpha S} = \int V_{\alpha S} - I_{\alpha S} \cdot R_S dt \quad (5)$$

$$\lambda_{\beta S} = \int V_{\beta S} - I_{\beta S} \cdot R_S dt. \quad (6)$$

From the previous equations, the flux magnitude and angle of the estimated stator flux can be written as:

$$|\lambda_S| = \sqrt{\lambda_{\alpha S}^2 + \lambda_{\beta S}^2} \quad (7)$$

$$\theta = \tan^{-1} \left(\frac{\lambda_{\beta S}}{\lambda_{\alpha S}} \right). \quad (8)$$

Finally, the electromagnetic torque of the motor can be estimated using the following cross product:

$$T_{em} = \frac{3}{2} \cdot \frac{P}{2} \cdot (\bar{\lambda}_S \times \bar{I}_S) \quad (9)$$

where P is the number of poles of the induction motor.

From Equation (4), one can note that the induction motor stator flux can be estimated through the integration of back electromotive force (Idris & Yatim, 2001), (Holtz, 2003), (Zerbo et al., 2005). This method requires only the stator resistance parameter. Besides, it is independent of the rotor position or the speed information. However, this method presents inherent problems related to pure integration, mainly the motor operating at nearly zero speed when the voltage drop in stator resistance become significant. This approach tends to be inaccurate because the integrators do not operate well at speeds near zero as there is no motor-induced back electromotive force.

When a pure integration is implemented in the discrete form, an error can arise. This error comprises the drift produced by the discrete integration and also the drift produced by measurement offset error present in the back electromotive force (Holtz, 2003), (Xu, X. & Novotny, D. W. 1991). A small DC component can drive the pure integration into saturation.

To reduce integration problems, (Nied et al., 2010) adopted a simple approach utilizing a low-pass filter to estimate the induction motor stator flux.

As can be verified in Fig. 8, using the estimated stator flux and the measurement stator current, the instantaneous electromagnetic torque produced by the induction motor is obtained. The flux estimation method is based on the following steps:

- Using a high-pass filter after the stator voltage and current analog readings, designed with cutoff frequency one decade below the excitation frequency to eliminate DC offset presented in stator voltage and current analog readings, (Zerbo et al., 2005);
- Using a low-pass filter designed with cutoff frequency one decade below the excitation frequency to substitute the pure integrator and to eliminate high frequency noises presented in analog readings (Idris & Yatim, 2001).

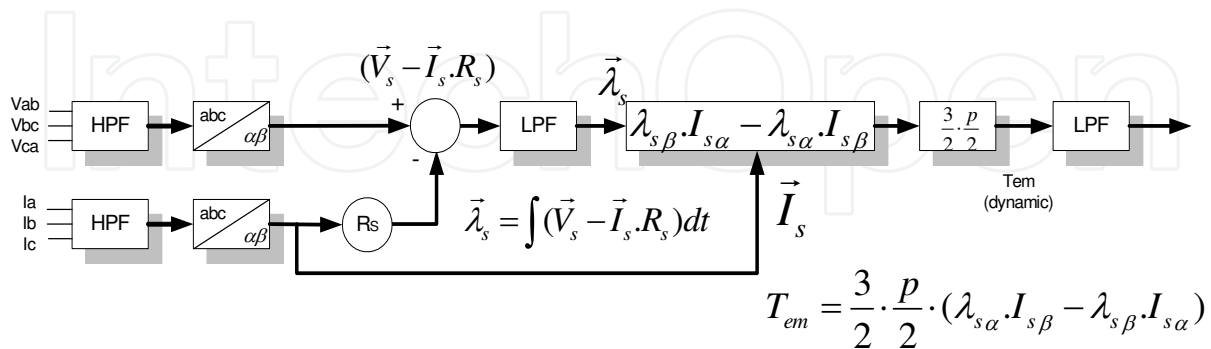

Fig. 8. Diagram of the induction motor electromagnetic torque estimator based on an integrator with offset minimization.

To eliminate the ripple presented in estimated electromagnetic torque, another first order low-pass filter was used. The second low-pass filter was designed in the same manner as the first low-pass filter, generating the filtered electromagnetic torque curve.

In the next section, the comparative results of two techniques are presented: current control and torque control. Using the torque control technique for tracking a reference torque results in an improved energy efficiency of induction motor starting.

4. Study of energy efficiency

Experiments were carried out to verify the performance of the torque control technique. One standard induction motor with the following motor data in physical units was tested: power 300 CV (220 kW), rated voltage 440 V, rated current 345 A, rated speed 1790 rpm, 4 poles. Due to the high current and power values, the experimental setup comprised a soft starter with torque control and a rated current of 365 A, a dc machine (300 kW) working as a dynamometer, an oscilloscope and an energy analyzer. Fig. 9 shows the hardware that was used to obtain the experimental results. In addition, it must be noted that, for the two first experiments the load torque (T_L) was a constant value.

The induction motor starting waveforms of speed, acceleration and RMS line current *versus* time are shown in Figs. 10–12. Three experiments were performed:

- Experiment 1: starting performance using the *current* control technique (Fig. 10);
- Experiment 2: starting performance using the *torque* control technique (Fig. 11);
- Experiment 3: starting performance using the *torque* control technique and considering *three reference points* for T_{REF} (Fig. 12).

Figures 10 and 11 show the starting results obtained from the motor using two different soft-starting strategies. As can be seen in Fig. 10, despite the fact that the line current is limited, there is an acceleration pulse, i.e., the acceleration is almost constant except at the final period of the starting process when the acceleration increases, at least, by two times. This behavior is not desired, and it may damage the mechanical system components.

Considering the current control technique, when starting the motor, the SCRs' trigger angle is controlled until the current limit is reached and remains under this limit until the motor reaches its rated speed, when the SCRs' trigger angle is minimum, i.e., the same as that of the supply voltage. The current can thus be kept constant at a predefined value during the whole motor starting time. However, with regard to the torque at the motor shaft, the existence of a torque pulse close to nominal rotation is due to the SCRs' trigger angle which becomes minimum, imposing a feeding voltage and sudden motor acceleration.



Fig. 9. View of the hardware used to obtain experimental results.

In Fig. 10, it can be noted that the motor starting time is about 25 seconds. It can be verified too that the current maximum value was limited to around two times as the nominal current value.

It can be observed that the current control technique limits the high inrush current transient inherent in induction motors with electromagnetic line starters. Besides, it can be noted during most of the motor starting process that the acceleration is constant and around 1 rot/s^2 . However, during the final period of the motor starting process, one can observe an abrupt acceleration around 2.5 times more than the constant acceleration.

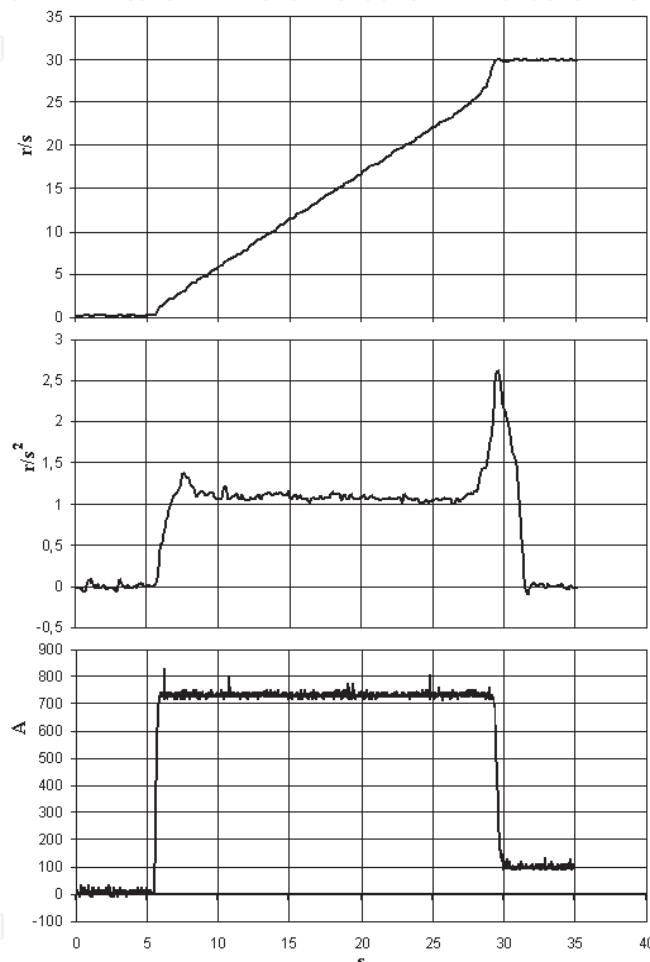

Fig. 10. Speed, acceleration and current obtained in Experiment 1 using the current control technique.

Measures of energy consumption for this experiment were taken. The measured value for the energy consumed due to active power was 0.531 kWh and the amount due to reactive power was 3.592 kVARh.

Similar current behavior is verified for the torque control technique in Fig. 11, which can be obtained by setting T_{REF} to a constant value, i.e., one point of reference. However, in this case, there is no torque pulse, the speed is quite smooth, and an abrupt acceleration is no longer recognized. Observe that the control is acting directly on the torque profile which is different from the current-control case, where the control did not act directly on the torque profile.

From the torque control technique characteristics, it can be verified that:

- The speed slope is linear throughout the starting process, avoiding the pulse acceleration recorded in the current control technique;
- The acceleration waveform presents approximately linear behavior;
- The current waveform was very close to that observed in the current control technique.

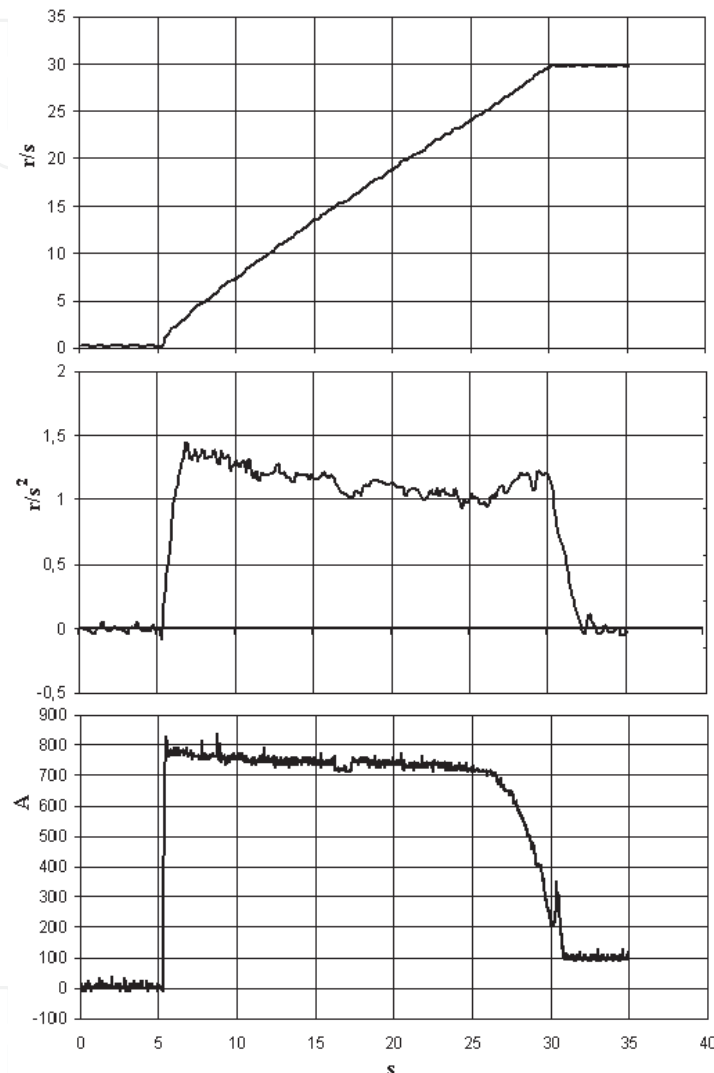

Fig. 11. Speed, acceleration and current obtained in Experiment 2 using the torque control technique.

Measures of energy consumption for Experiment 2 were taken too. The measured value for the energy consumed due to active power was 0.550 kWh and the amount due to reactive power was 3.691 kVARh.

In Fig. 12, three reference points for T_{REF} were considered. In this case, unlike the waveforms shown in Fig. 11, a torque ramp of two different shapes was tailored: In the first-half starting period, a rising torque ramp was defined, and after that, a descending torque ramp was defined. This behavior can be observed in the acceleration waveform. As a consequence, the speed waveform looks like an S with a smooth behavior at the beginning and at the end of the starting period. The motor RMS line current follows the shaft-torque reference behavior.

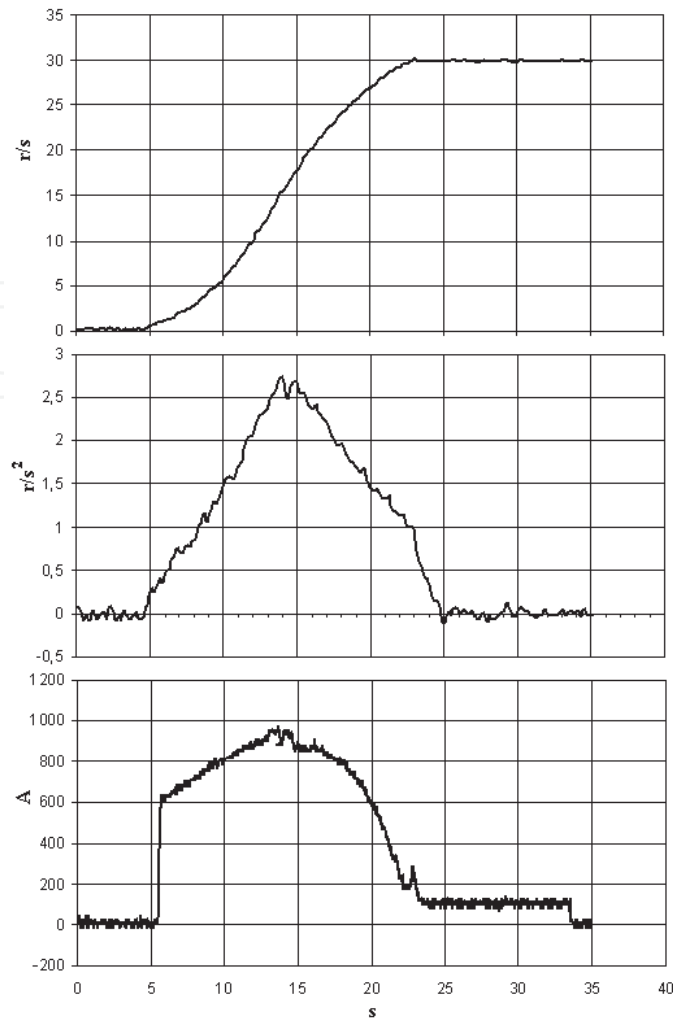

Fig. 12. Speed, acceleration and current obtained in Experiment 3 using the torque control technique and considering three reference points for T_{REF} .

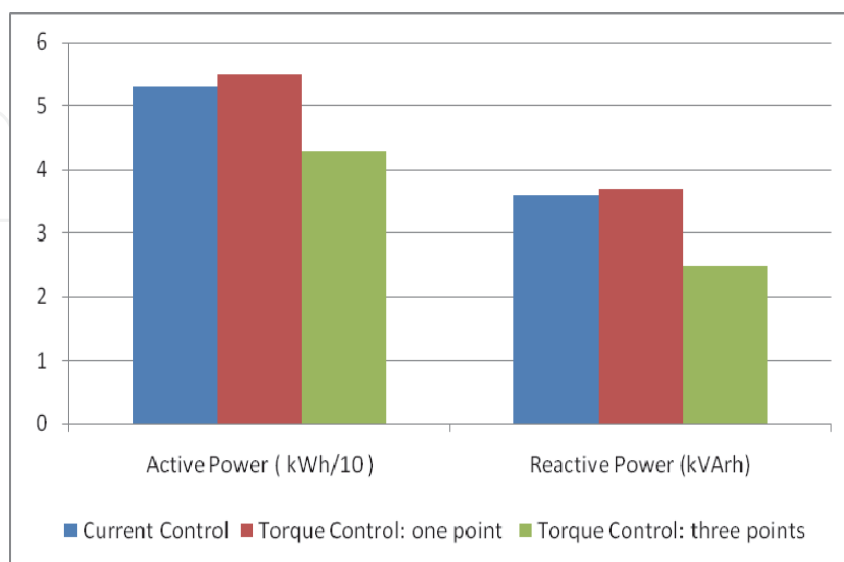

Fig. 13. Bar graph of the experimental results.

Measures of energy consumption for Experiment 3 were taken. The measured value for the energy consumed due to active power was 0.430 kWh and the amount due to reactive power was 2.484 kVArh.

The bar graph shown in Figure 13 compares the values of consumed energy (active power and reactive power) for the three experiments.

Comparing the values of energy consumed in Experiments 1 and 2, it appears that the difference is not appreciable. This fact can be justified because of the similarity in the behavior of the magnitudes shown in Figs. 10 and 11.

Based on the values of energy consumption obtained in Experiments 1 and 3, there is an energy savings of about 19% in active power and reactive power at 31%. These savings of energy were expected due to the fact that in Experiment 3, a current value higher than in Experiments 1 and 2 was allowed in a shorter time.

5. Conclusion

Minimum standards for energy efficiency have been the basis for policies used by states and government to save energy. The study presented in this chapter followed the idea of developing innovations that bring better performance. It was shown that with a new control technique for the soft-starter, it is possible to save energy by improving induction motor drive.

The soft-starters for working with fixed frequency are devices that have some limitations for the implementation of more sophisticated control strategies, for example, those employed in three-phase inverters used in controlled speed drives. Despite this fact, it was shown that it is feasible to implement a soft-starter with control of electromagnetic torque. Using this control technique in the soft-starter allows the adjustment of motor torque curve to the needs of the driven load, thus improving the performance of the drive during transient starting and stopping. This technique becomes important in cases where the motor is subjected to a regime of very intense work, such as elevators and large commercial presses.

The experimental results showed the effectiveness of the presented technique, eliminating the peak torque occurring at the end of the motor starting process when using the current control technique. Moreover, depending on the flexibility to adapt to the type of load inertia, made possible by adjusting the torque reference, it was shown that it is possible to obtain an energy savings of about 19% in active power and reactive power at 31% depending on the type of drive that you need to perform.

6. Acknowledgments

The authors wish to acknowledge the support provided by UDESC and WEG Equipamentos Elétricos for this investigation.

7. References

- Bruce, F. M.; Graefe, R. J.; Lutz, A. & Panlener, M. D. (1984). Reduced-Voltage Starting of Squirrel-Cage Induction Motors. *IEEE Transactions on Industry Applications*, Vol.IA-20, No.1, (January/February 1984), pp. 46-55, ISSN 0093-9994.
- Colleran, P. J. & Rogers, W. E. (1983). Controlled Starting of AC Induction Motors. *IEEE Transactions on Industry Applications*, Vol.IA-19, No.6, (November/December 1983), pp. 1014-1018, ISSN 0093-9994.

- Gritter, D. ; Wang, D. & Habetler, T. G. (2000). Soft Starter inside Delta Motor Modeling and Its Control, *Proceedings of Industry Applications Conference*, ISBN 0-7803-6401-5, Rome, Italy, October 2000.
- Holtz, J. (2003). Drift-and Parameter-Compensated Flux Estimator for Persistent Zero-Stator-Frequency Operation of Sensorless-Controlled Induction Motors. *IEEE Transactions on Industry Applications*, vol.39, No.4, (July/August 2003), pp. 1052-1060, ISSN 0093-9994.
- Idris, N. R. N. & Yatim, A. H. M. (2001). Direct Torque Control of Induction Machines with Constant Switching Frequency and Improved Stator Flux Estimation, *Proceedings of IEEE 27th Annual Industrial Electronics Society Conference*, ISBN 0-7803-7108-9, Colorado, USA, November/December 2001.
- IEEE-USA. (19.11.2010). Energy Efficiency, In: *Energy & Environment - National Energy Policy Recommendations*, 23.03.2011, Available from: <www.ieeeusa.org/policy/positions>.
- Leonhard, W. (1988). Field-orientation for controlling AC machines - principle and application. *Third International Conference on Power Electronics and Variable-Speed Drives*, ISBN 0-85296-364-5, London, UK, July 1988.
- Nevelsteen, J. & Aragon, H. (1989). Starting of Large Motors - Methods and Economics. *IEEE Transactions on Industry Applications*, Vol.25, No.6, (November/December 1989), pp. 1012-1018, ISSN 0093-9994.
- Nied, A.; Dias, R. P.; de Oliveira, J.; Campos, R. de F & Marques, L. C. de S. (2008). Soft Starting of Induction Motor with Torque Control, *Proceedings of Industry Applications Society Annual Meeting*, ISBN 978-1-4244-2278-4, Edmonton, Canada, October 2008.
- Nied, A.; de Oliveira, J.; de Farias Campos, R.; Dias, R. P. (2010). Soft Starting of Induction Motor With Torque Control. *IEEE Transactions on Industry Applications*, Vol.46, No.3, (May/June 2010), pp. 1002-1010, ISSN 0093-9994.
- Palma, J. C. P. (1999). *Accionamentos Electromecânicos de Velocidade Variável*, Fundação Calouste Gulbenkian, ISBN 972-31-0839-9, Lisboa, Portugal.
- U.S. Energy Information Administration. (27.07.2010). World Energy Demand and Economic Outlook, In: *International Energy Outlook 2010*, 23.03.2011, Available from: <www.eia.doe.gov/oiaf/ieo/world.html>
- World Energy Council. (06.2009). Energy Efficiency Can Lead the Economic Recovery, In: *WEC Comment*, 23.03.2011, Available from: <www.worldenergy.org/news_events/wec_comment/2118.asp>
- Xu, X. & Novotny, D. W. (1991). Implementation of Direct Stator Flux Orientation Control on a Versatile DSP Based System. *IEEE Transactions on Industry Applications*, Vol.27, No.4, (July/August 1991), pp.694-700, ISSN 0093-9994.
- Zenginobuz, G.; Cadirci, I.; Ermis, M. & Barlak, C. (2001). Soft-Starting of Large Induction Motors at Constant Current with Minimized Starting Torque Pulsations. *IEEE Transactions on Industry Applications*, Vol.37, No.5, (September/October 2001), pp. 1334-1347, ISSN 0093-9994.
- Zerbo, M.; Sicard, P.; Ba-Razzouk, A. (2005). Accurate Adaptive Integration Algorithms for Induction Machine Drive over a Wide Speed Range, *IEEE International Conference on Electric Machines and Drives*, pp. 1082-1088, ISBN 0-7803-8987-5, San Antonio, USA, May 2005.

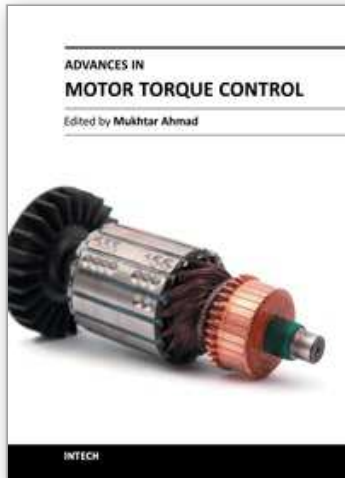

Advances in Motor Torque Control

Edited by Dr. Mukhtar Ahmad

ISBN 978-953-307-686-7

Hard cover, 144 pages

Publisher InTech

Published online 22, September, 2011

Published in print edition September, 2011

Electric motors are widely used in industries to convert electrical energy into mechanical form. Control techniques are designed to improve the performance and efficiency of the drive so that large amounts of electrical energy can be saved. This book is primarily written with the objective of providing necessary information on use of electric motors for various applications in industries. During the last ten years a number of methods of control of electric drives have emerged. Some of these methods are described in this book. The reader will be able to understand the new methods of control used in drives, e.g. direct and sensorless control. Also the application of motor control in dentistry, the effect of human reaction and improvement of the efficiency of drives with control have been described.

How to reference

In order to correctly reference this scholarly work, feel free to copy and paste the following:

José De Oliveira, Ademir Nied and Rogério Pinho Dias (2011). Study on Energy Efficiency of Induction Motor Soft-Starting with Torque Control, *Advances in Motor Torque Control*, Dr. Mukhtar Ahmad (Ed.), ISBN: 978-953-307-686-7, InTech, Available from: <http://www.intechopen.com/books/advances-in-motor-torque-control/study-on-energy-efficiency-of-induction-motor-soft-starting-with-torque-control>

INTECH
open science | open minds

InTech Europe

University Campus STeP Ri
Slavka Krautzeka 83/A
51000 Rijeka, Croatia
Phone: +385 (51) 770 447
Fax: +385 (51) 686 166
www.intechopen.com

InTech China

Unit 405, Office Block, Hotel Equatorial Shanghai
No.65, Yan An Road (West), Shanghai, 200040, China
中国上海市延安西路65号上海国际贵都大饭店办公楼405单元
Phone: +86-21-62489820
Fax: +86-21-62489821

© 2011 The Author(s). Licensee IntechOpen. This chapter is distributed under the terms of the [Creative Commons Attribution-NonCommercial-ShareAlike-3.0 License](#), which permits use, distribution and reproduction for non-commercial purposes, provided the original is properly cited and derivative works building on this content are distributed under the same license.

IntechOpen

IntechOpen