

We are IntechOpen, the world's leading publisher of Open Access books Built by scientists, for scientists

4,800

Open access books available

122,000

International authors and editors

135M

Downloads

Our authors are among the

154

Countries delivered to

TOP 1%

most cited scientists

12.2%

Contributors from top 500 universities



WEB OF SCIENCE™

Selection of our books indexed in the Book Citation Index
in Web of Science™ Core Collection (BKCI)

Interested in publishing with us?
Contact book.department@intechopen.com

Numbers displayed above are based on latest data collected.
For more information visit www.intechopen.com



Numerical Modelling and Simulation of Radial-Axial Ring Rolling Process

Lianggang Guo and He Yang

State Key Laboratory of Solidification Processing, School of Materials Science and Engineering, Northwestern Polytechnical University, Xi'an, PR China

1. Introduction

Ring rolling has been a kind of irreplaceable near-net-shape metal forming technology for the manufacture of various ring-shaped parts with high performance and high precision, such as various bearing races, ring gears, aero-engine casing, nuclear reactors parts and various connecting flanges, due to the most important advantages of the favourable grain flow and good surface quality of the rolled rings (Eruc & Shivpuri, 1992). Radial-axial ring rolling, the forming principle of which is shown in Fig.1, is a classic form of ring rolling process and is usually adopted to manufacture various high-quality large rings widely served in many important industry areas such as aerospace and wind power. During the process, the main roll rotates at a rotational speed n_1 ; the mandrel squeezes the ring wall at a feed rate v_f and runs idle because of the friction on the contact surface; the axial rolls, including the upper and lower conical rolls, are driven to rotate at an inverse speed n_a around their axes and to withdraw at a speed v_w with the increasing of the ring diameter to maintain a minimum relative slip between the axial rolls and the end faces of the ring; at the same time, the upper conical roll slides toward the lower conical roll at a feed rate v_a to cause axial height reduction of the ring, while the lower conical roll is held in a fixed position above the table plate of the radial-axial mill; the guide rolls contact the ring outer diameter to ensure the circularity of the ring, and any force imbalance and instability during the rolling process are removed by the actions of the guide rolls. Under the cooperative actions of all the rolls, the ring blank rotates and produces plastic deformation of reduction in cross-section and growth in diameter.

From the forming principle of radial-axial ring rolling, it can be known that the process is characterized by extremely complicated dynamic forming and high flexibility due to multiple independent control system for the three sets of rolls, namely, the radial main roll and mandrel, two axial conical rolls and two guide rolls, as illustrated in Fig. 1. What's more, in consideration of microstructure evolution of ring materials and the final performance of the rolled ring, the thermal-coupled plastic deformation behavior of the process and response of ring materials properties to the process are necessary and significant concerns for the design, operation and optimization of the process. In practice, the radial-axial ring rolling process usually presents uncooperative motions of the rolls, severe instabilities thus usually rolls rings with various macro and micro defects due to unreasonable design of process parameters (mainly including the sizes of ring blank,

forming temperature and various motion parameters such as v_f , n_1 , v_{ar} , n_{ar} and v_w , as show in Fig. 1) and severe dynamic contacts and collisions between the ring and the rolls. Thus, the optimal design and precise control of the actual process and the quality control of the rolled rings are faced with huge challenges and difficulties.

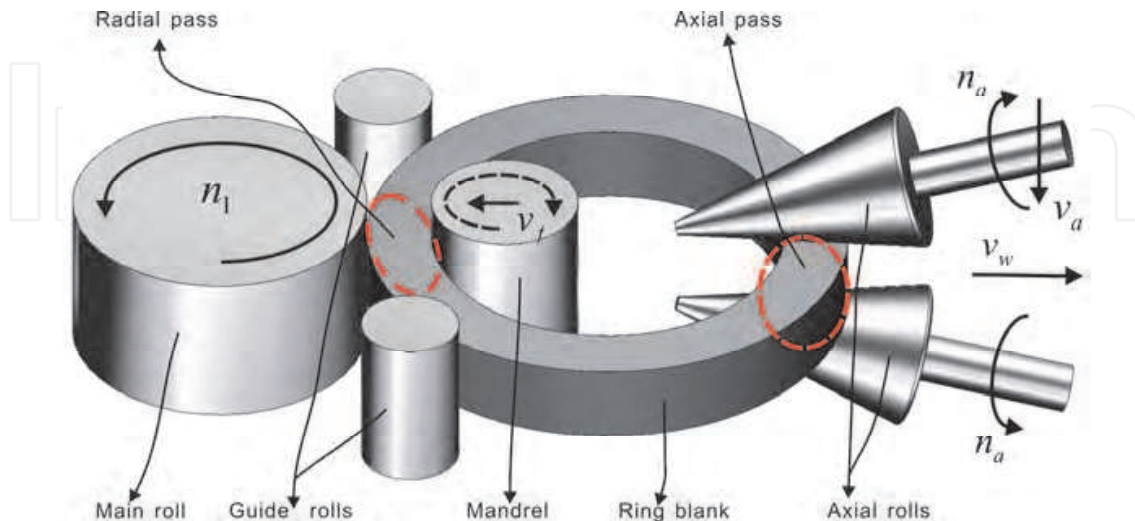

Fig. 1. Forming principle of radial-axial ring rolling

Due to the above concerns, the key science problem, which must be solved for the R&D of radial-axial ring rolling technology, is the evolution mechanism of geometry and microstructure of ring blank during the process. This is because the final precision of shape and size of the rolled ring depends on the evolution mechanism of the geometry of the ring blank, and the final performance of the rolled ring depends on the evolution mechanism of the microstructure of the ring blank. Solving the above science problem is the theoretical basis for the optimal design and steady control of the process. However, it is difficult to solve the above science problem only by experiment or theory analysis or numerical simulation because of the complexity of the process.

FE numerical modeling and simulation has been proven to be a powerful and accurate method to study plastic deformation behavior of various complicated metal forming processes (Yang et al. 2004), and can conduct more comprehensive, profound, and detailed investigations compared with the analytical and experimental methods. So, FE numerical modeling and simulation combined with theoretical analysis and experimental observation has been a powerful means for many metal forming processes such as forging, extrusion, spinning, tube bending and various rolling technologies including flat rolling, ring rolling, and so on.

So far, the ring rolling technology has evolved over 150 years. Allwood et al. (2005) reviewed the contributions of 174 papers by a thorough survey of work on ring rolling published in the English and Germany languages by 2004. Many studies on the ring rolling technology have been carried out by many researchers through experiment, theoretical analysis or numerical simulation. Johnson et al. (1968) carried out earlier experimental works on ring rolling. Hawkyard et al. (1973) reported a theoretical prediction for the roll force and torque during ring rolling between plain cylindrical rolls, and examined the prediction accuracy by experimental measurements of roll force and torque. Mamalis et al. (1975) investigated the cavity formation by rolling profiled (T-shaped) rings experimentally.

Lugora et al. (1987) analyzed the spread in plain ring rolling using Hill's general method of analysis. Hahn et al. (1994) reported the UBET analysis of the closed-pass ring rolling of rings having arbitrarily shaped profiles.

With the rapid development of numerical calculation and computer technologies, FE numerical simulation technology was widely employed to investigate deformation mechanics of ring rolling. Kim et al. (1990) reported a finite element code 'RING' which was developed for the three-dimensional deformation analysis of ring rolling. Yang et al. (1991) simulated the T-section profile ring rolling processes by rigid-plastic finite element method. Kang & Kobayashi (1991) and Joun et al. (1998) carried out the studies on preform design in ring rolling using the backward tracing scheme and an axisymmetric forging approach, respectively. Davey & Ward (2003) presented an ALE approach for finite element ring-rolling simulation to save computational cost. Based on the finite element method, Forouzan et al. (2003) proposed a new method (thermal spokes) to simulate the guide roll effect in FE analysis of the ring rolling process.

In recent years, many advances in ring rolling were obtained mainly by FE numerical simulations. For example, Wang et al. (2007) developed a virtual radial-axial ring rolling process for guiding process design and optimization using the LS-DYNA FE code; Jong et al. (2007) investigated the radial-axial ring-rolling design of a large-scale ring product of Ti-6Al-4V alloy using a calculation method and FEM analysis; Moon et al. (2008) predicted the polygonal-shaped defects during hot ring rolling using a rigid-viscoplastic finite element method; Hua et al. (2009) established a ring stiffness condition in radial-axial ring rolling whose validity was evaluated by numerical simulation; Zhou et al. (2010, 2011) numerically analyzed the coupled thermo-mechanical behaviors in radial-axial rolling of alloy steel large ring and revealed the effects of roll size on the process, and so on.

Facing with national needs in aerospace area, our research team, namely lab of precision plastic forming (LPPF) led by Professor He Yang in Northwestern Polytechnical University of China, has continuously engaged in investigating various complicated and special metal forming processes, such as NC tube bending (Yang et al., 2010; Zhan et al., 2006; Li et al., 2010), precision die forging and local loading forming (Yang et al. 2002; Liu et al., 2002; Fan et al., 2010), spinning (Yang et al., 2010; Zhan et al., 2007) and ring rolling (Guo et al., 2005; Yang et al., 2008; Guo & Yang, 2011). In the aspect of ring rolling, we achieved many important findings in past several years. For example, Yang et al. (2008) investigated the effects of blank size on strain and temperature distribution during hot rolling of titanium alloy large rings by 3D coupled thermo-mechanical FE simulations; Guo et al. (2005) revealed the plastic deformation behavior in cold ring rolling by FE simulation and proposed three kinds of plastic deformation behaviors of pure radial ring rolling process. Guo & Yang (2011) developed mathematical model of a steady forming condition for radial-axial ring rolling and demonstrated its validation by FE simulations; Li et al. (2008) reported a control method of guide rolls in 3D-FE simulation of ring rolling; Wang et al. (2009) revealed the coupled mechanical and thermal behaviours in hot rolling of large rings of titanium alloy using 3D dynamic explicit FEM, and so on. The relevant studies on the above metal forming technologies have attained supports of many national major research programs such as the Natural Science Foundation of China, National Basic Research Program of China ("973" Program), National Major Science and Technology Special Projects of China and National High Technology Research and Development Program of China ("863" Program).

In this book chapter, we first propose a high-end research route for aerospace plasticity technology in terms of our understanding and research experiences on various metal

forming processes and give an application example of it for the investigation of radial-axial ring rolling technology, then discuss the involved key FE modelling technologies and reliability of the developed thermo-mechanical coupled 3D-FE model for the entire radial-axial ring rolling process, next report some simulation results including ring geometry evolution, stress field, strain field, temperature field, rolling forces and torques in the radial and axial directions during the process, afterwards summarize the conclusion and future work, and finally express our acknowledgement for the support given to this work.

2. High-end research route for aerospace plasticity technology

With the rapid development of aerospace industry, various key aerospace components need to be manufactured by plasticity technology for the fabrication of high-end aerospace equipments. But due to the severe service environment in aerospace area, manufacturing various key components, which have features of light weight, high precision, high performance, high reliability and high efficiency, has been the eternal goal for the R&D of advanced technology of plasticity. Therefore, the R&D of the aerospace plasticity technology is facing with huge challenges as discussed below.

2.1 Challenges for aerospace plasticity technology

In consideration of the requirements of light weight, high precision, high performance, high reliability and high efficiency for the key aerospace components, the main challenges for the R&D of aerospace plasticity technology are concisely summarized as follows.

1. Various difficult-to-deform and expensive materials such as titanium alloy, which have high strength, poor ductility, low elastic modulus and complicated microstructure but possess low density, good corrosion resistance and high temperature resistance, are employed to manufacture the key aerospace components, thus leading to difficulties for the R&D of aerospace plasticity technology.
2. The geometry structures of the key aerospace components become larger, thinner, more integral and more complex, which result in complicated preform design, ultrahigh forming load, inhomogeneous microstructure and performance, loose geometry tolerance and complicated dies for their plastic forming thus leads to huge challenges to the aerospace plasticity technology.
3. The plastic forming process of the key aerospace components is influenced interactively by multi-factors including material parameters (initial microstructure and various physical or chemical properties), process parameters (temperature, strain rate and degree of deformation, etc), geometry parameters (blank or preform size, product size and die size), so is highly nonlinear due to its material, boundary and geometry nonlinearity. The coupled effects of multi-factors and high nonlinearity lead to huge challenges to the aerospace plasticity technology.

Therefore, it is essential and urgent to find certain advanced methodology for the R&D of the aerospace plasticity technology. In terms of our understanding and research experiences on various metal forming technologies, we propose the following high-end research route for the aerospace plasticity technology.

2.2 Proposing of high-end research route for aerospace plasticity technology

In consideration of challenges for plasticity technology in aerospace area, a high-end research route for aerospace plasticity technology is proposed as illustrated in Fig. 2.

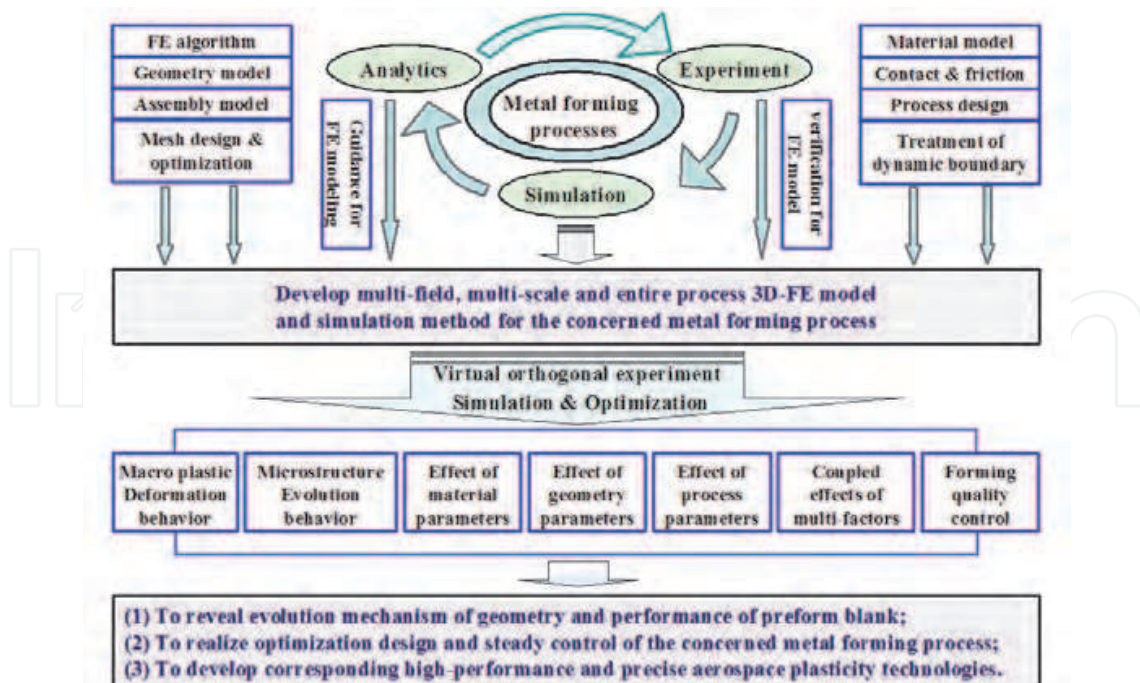

Fig. 2. High-end research route for aerospace plasticity technology

Due to the complexity of metal forming processes, FE numerical simulation organically combined with analytics and experiment is employed to investigate the forming mechanism of various metal forming processes. The relationships among the analytics, experiment and simulation are concisely discussed as follows.

The analytics is used to initially design the process parameters and provide basic understanding of the concerned metal forming process thus provides guidance and basis for FE modelling of the process. Of course, the analytics also can provide guidance for experiment. The experiment is used to verify the accuracy and reliability of the developed FE model. Also, the experiment can be used to verify the results obtained by analytics. And the prediction results obtained by simulation can provide detailed data information and important guidance for the analytics, experiment and actual production process.

Therefore, synthetically using analytics, experiment and FE numerical modeling technologies such as FE algorithm selection, mesh design and optimization, materials modelling, definition of contact and friction, and treatment of dynamic boundary, developing multi-field, multi-scale and entire process 3D-FE model and carrying out comprehensive simulation & optimization have been an advanced and unique methodology for investigating the concerned metal forming process. The multi-field, multi-scale and entire process 3D-FE model can be used as a virtual experimental platform to rapidly and inexpensively carry out various investigations about the concerned metal forming technology. The research contents, which can be carried out by the virtual experimental platform, include macro plastic deformation behavior, microstructure evolution behavior, effects and coupled effects of various factors (material, process and geometry parameters), and the prediction and control of various macro and micro forming defects, etc. The research aims for the concerned metal forming process are to reveal evolution mechanism of geometry and performance (microstructure) of the preform blank, to realize optimal design and steady control of the process and to develop high-performance and precise aerospace

plasticity technologies. And in Fig.2, the virtual orthogonal experiment is employed to design simulation experimental schedule for the purpose of saving calculation cost as far as possible. The simulation and optimization methods are combined to realize optimal design of the concerned metal forming process so as to obtain defect-free and high-performance deformed products.

2.3 High-end research route for radial-axial ring rolling technology

As an application example of the above proposed methodology for the investigation of aerospace plasticity technology, the high-end research route for radial-axial ring rolling technology has been given in Fig. 3 in consideration of the features of the process.

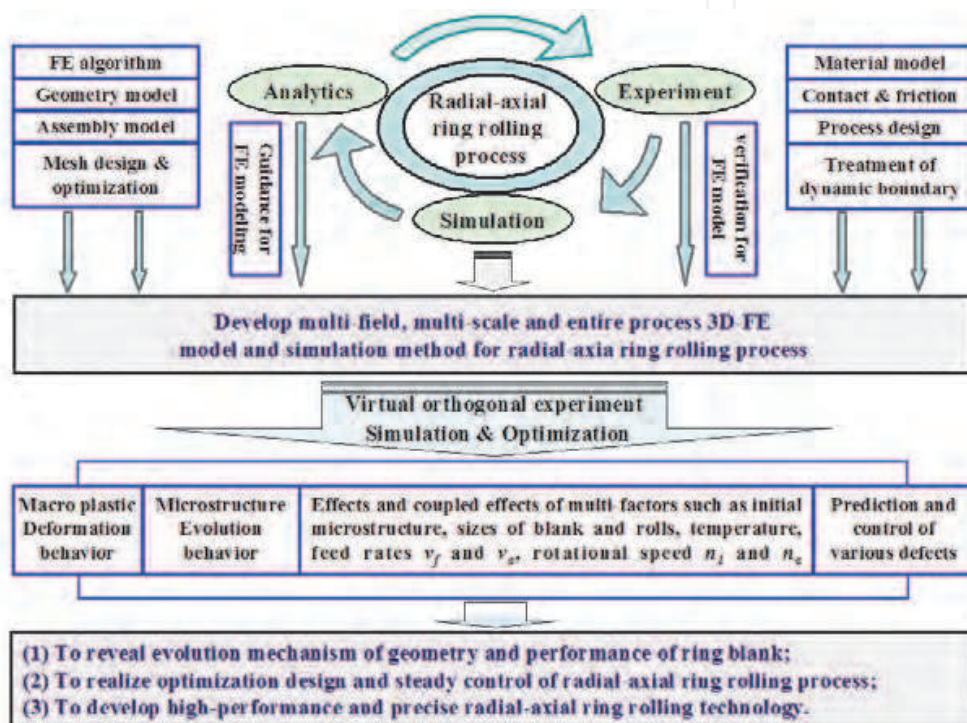

Fig. 3. High-end research route for radial-axial ring rolling technology

The high-end research route for radial-axial ring rolling technology actually outlines the key technologies, methods, contents and aims for the investigation of the process, which can be regarded as an overall planning for the implementation of various research tasks.

3. Numerical modelling of radial-axial ring rolling

Under ABAQUS/Explicit software environment, we developed a coupled thermo-mechanical 3D-FE model for the entire radial-axial ring rolling process, as shown in Fig.4 (Guo & Yang, 2011). The dynamic explicit FEM and mass scaling are used in the model to speed up the computation.

However, the model can only be used to investigate the coupled thermo-mechanical deformation behaviour but can not predict the microstructure evolution of ring blank. But the current model will be an important basis for the simulation of microstructure evolution. The involved key FE modelling technologies are discussed as follows in detail.

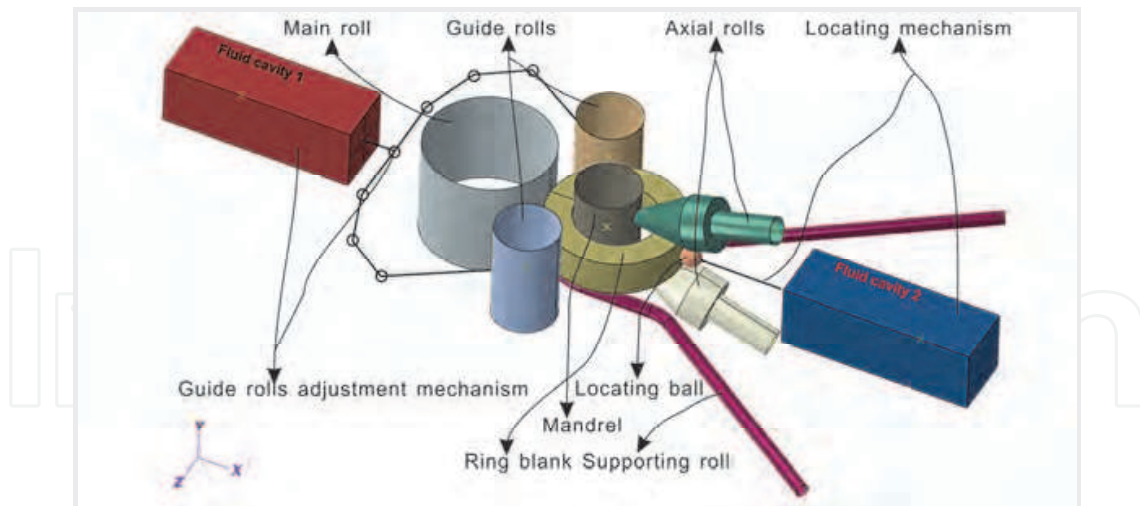

Fig. 4. The coupled thermo-mechanical 3D-FE model for the entire radial-axial ring rolling process

3.1 Key FE modeling technologies

The involved key technologies for the FE modelling of radial-axial ring rolling process mainly include geometry and assembly model, mesh design and optimization, material model, model of guide rolls control mechanism, contact and friction, and determination of the paths of the rolls.

3.1.1 Geometry and assembly model

Geometry model describes the shape and size of every geometry part in the FE model. In Fig.4, all the geometry parts include the ring blank, main roll, mandrel, two guide rolls, two axial conical rolls, supporting rolls, locating ball, guide rolls adjustment mechanism and locating mechanism used to capture the position of the locating ball so as to define the translation motion of the axial rolls in the X direction. The ring blank is modelled by deformable solid body which can be assigned certain material properties. All the rolls and locating ball are modelled by non-deformable analytic rigid surface bodies. For the guide rolls adjustment mechanism and locating mechanism, the fluid cavities are modelled by surface elements based on surface-based fluid cavities technology and the linkages used to control the guide rolls and locating ball are modelled by various connector elements such as beam, weld and hinge. The locating mechanism is designed to capture the growth behavior of the ring throughout the simulation of the radial-axial ring rolling process. Then based on the captured growth behavior of the ring, the translation motion of the axial rolls in the X direction can be conveniently controlled. A small force acting on the end-face of the fluid cavity 2 (as shown in Fig. 4) is preset to avoid appreciable effects on the radial-axial ring rolling process caused by the locating ball. The supporting roll is designed to support the gravity of the ring.

The assembly model is used to describe the relative position relationships among all the geometry parts. In consideration of the spread deformation of the ring in the axial direction, the supporting roll is located below the lower end-face of the ring about 3mm for the FE model shown in Fig.4. It is noted that the linkages for the control of the guide rolls and location ball should be designed to have enough motion space when the ring grows to the maximum diameter. Fig. 4 fully demonstrates the assembly model describing the relative position relationships among all the geometry parts.

3.1.2 Mesh design and optimization

Mesh design and optimization involves selection of element type, check of mesh quality, determination of element size and mesh convergence study, etc.

In the FE model shown in Fig.4, all the rolls and locating ball need not be meshed because they are modelled by rigid surface bodies; the fluid cavities are meshed by surface elements; the linkages are meshed by various connector elements such as beam, hinge and weld; and the ring is meshed by the coupled thermo-mechanical hexahedron element with eight nodes (C3D8RT). An adaptive mesh domain is created for the entire ring to maintain a high-quality mesh throughout an analysis, and reduction integration and hourglass control are employed to save computational time and avoid the zero-energy mode caused by the bending mode of deformation, respectively.

The mesh size is optimized by performing a mesh convergence study, where the same problem is simulated with a different level of refinement of the mesh, and then the simulation results are compared. If further mesh refinement produces a negligible change in the solution, the mesh is said to be converged.

3.1.3 Material model

Material model is used to describe the response of material properties to the coupled thermo-mechanical plastic deformation in metal forming processes and is the key concern for the prediction accuracy of the FE model. The material data, which should be given for the development of FE model, include stress-strain curves under different temperature and strain rate, temperature-dependent physical properties (including linear expansion coefficient, thermal conductivity, specific heat and Young's modulus), density and Poisson ratio, etc.

In Fig.4, the ring material used in the FE model is GH4169 alloy (Chinese grades), equivalent to IN718 alloy of American grades. All the material data stated above are given in the literature (Guo & Yang, 2011). For other geometry parts except the ring, material data need not be assigned to them because they are modeled by either rigid bodies or surface elements for fluid cavities and connector elements for linkages in the guide adjustment mechanism and locating mechanism.

3.1.4 Model of guide rolls control mechanism

The guide rolls play a significant role in both the circularity of the rolled ring and the stability of the radial-axial ring rolling process. Any force imbalance and instability during the rolling process can be removed by the actions of the guide rolls if well-controlled.

In the FE model shown in Fig.4, the guide rolls can be controlled adaptively by an adjustment mechanism which is modeled using the surface-based fluid cavities and connector element technologies in ABAQUS based on the method proposed by Li et al. (2008).

3.1.5 Contact and friction

Contacts are defined to transfer acting force, friction force and heat between the preform blank and various dies for the simulation of metal forming process by setting contact pairs, friction model and contact properties.

For the FE model of radial-axial ring rolling process shown in Fig.4, eight contact pairs are defined between the ring and the rolls. There exists friction and contact heat conduction at the interface of each contact pair. The modified Coulomb friction model is employed, and

the friction coefficients are assumed to be constant during an FE analysis. The guide rolls, supporting roll and locating ball are assumed as smooth surfaces so the friction coefficients on them are zero.

3.1.6 Determination of the paths of the rolls

Determination of the paths of the rolls is the basis for the definition of dynamic boundary conditions in the simulation of radial-axial ring rolling process. In ABAQUS, the amplitude curves with time of the rolls' motion parameters, including the feed rate of the mandrel v_f , rotational speed of the main roll n_1 , feed rate of the upper axial conical roll v_a , and rotational speed of the axial conical rolls as shown in Fig.1, can be used to define the paths of the rolls. However, as previously stated, the radial-axial ring rolling process usually exhibits uncooperative motions of the rolls and severe instabilities. The uncooperative motions of the rolls often lead to unexpected distortion of the ring. So it is a great challenge to successfully establish a radial-axial ring rolling process and maintain its stability. How to properly design the motion parameters of the rolls is the key to this problem. Only when the motion parameters are well-designed can the radial-axial ring rolling process be established successfully thus can the FE model of the process be developed successfully to investigate its deformation behavior.

Guo & Yang (2011) proposed a steady forming condition describing both the mathematic correlations and the reasonable ranges of the process parameters of radial-axial ring rolling. And through the developed mathematic model of the steady forming condition, the variation curves with rolling time of n_a , v_f , n_1 , v_a and n_a can be determined. These curves can be used as the motion amplitude curves of the rolls to define the dynamic boundary condition for the FE modeling of the radial-axial ring rolling process. The specific details for the determination of the rolls' paths can be referenced in the above literature. The determined paths of the rolls can ensure an approximately constant growth rate of the ring for the consideration of process stability. It is thus clear that analytics is a significant aid for the FE modeling of the metal forming process.

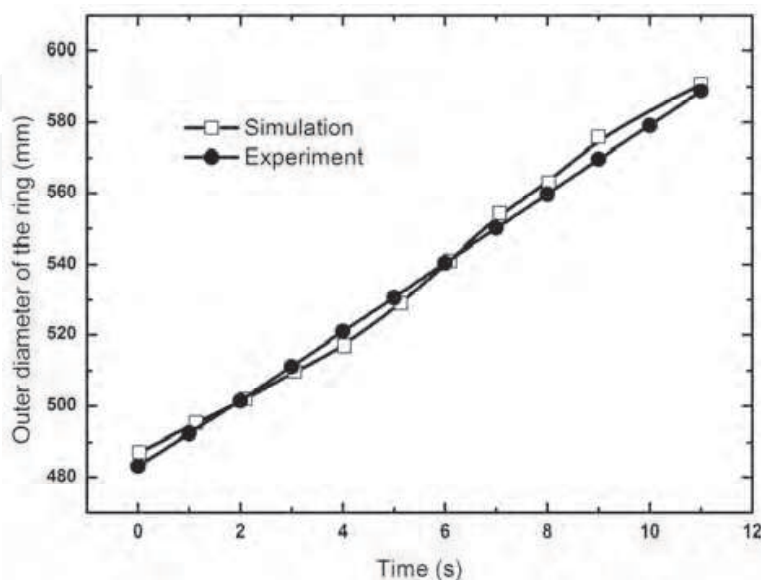

Fig. 5. Measured and predicted variation of the outer diameter of the ring with time

3.2 Model verification

The developed FE model for the radial-axial ring rolling process was verified by experiment in terms of the variations of the outer diameter of the ring and the roll forces in the radial and axial directions, as discussed in the literature (Guo & Yang, 2011).

Fig. 5 shows the measured and predicted variation of the outer diameter of the ring with time. It is seen that the predicted results are in good agreement with the measured ones. This indicates that the accuracy of the developed FE model is sufficient for the prediction of plastic deformation.

Fig. 6 shows the measured and predicted variations of the roll forces in the radial and axial directions with time at the stable rolling stage. It is observed that the predicted roll forces are the same order of the measured ones but with errors to some extent. Through a

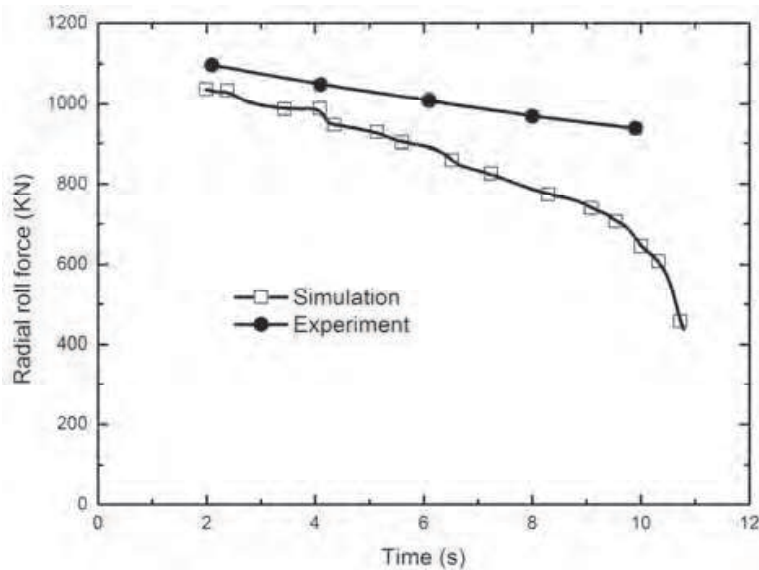

(a) radial roll force

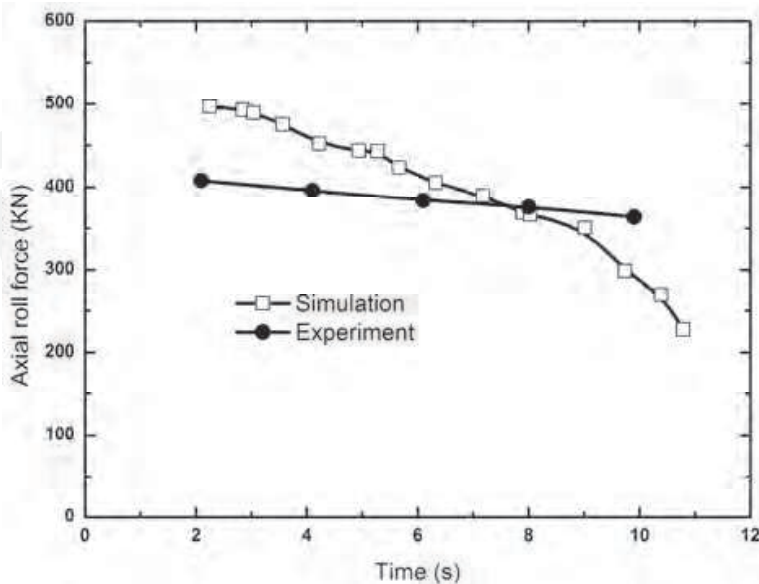

(b) axial roll force

Fig. 6. Measured and predicted variations of the roll forces at the stable rolling stage

comparison between measured and predicted results, the maximum relative errors of the radial and axial roll forces are about 10.3% and 21.6% at the stable rolling stage, respectively. The discrepancy between them could be caused by the errors arising from material properties, temperature, thermal boundary conditions, measurement operations and rolling schedules, etc. Therefore, the developed FE model for the radial-axial ring rolling process can be deemed to have enough accuracy and reliability for investigating the plastic deformation behavior of the process.

4. Numerical simulation of radial-axial ring rolling

A simulation case study for radial-axial ring rolling process has been carried out carefully based on the established virtual experimental platform, namely the coupled thermo-mechanical 3D-FE model of the process. For the simulation, the needed various data and parameters include material data, sizes of ring blank, rolled ring and all the rolls, various motion parameters describing the paths of the rolls, etc. These data and parameters all can be selected or determined by the above stated key FE modelling technologies in consideration of both the equipment condition and steady forming condition of the process. The detailed calculation conditions are given as follows.

4.1 Calculation condition

Table 1 gives the used material, sizes of ring blank, rolled ring and all the rolls, friction coefficient, initial temperature of the ring blank, and the rotational speed n_1 and n_a . n_1 is selected according to the equipment condition and n_a is determined by the relation between n_a and n_1 , i.e., $n_a = R_1 n_1 / R_{a1}$ given in the mathematic model of the steady forming condition (Guo & Yang, 2011). All the geometry size parameters listed in Table 1 are labelled in Fig. 7. And the relevant properties data of the used material can be found in the above literature.

Parameters	Value
The used material of ring blank	GH4169 alloy
Outer diameter of the ring blank D_0 (mm)	212.4
Inner diameter of the ring blank d_0 (mm)	130
Wall thickness of the ring blank b_0 (mm)	41.2
Height of the ring blank h_0 (mm)	57.4
Outer diameter of the rolled ring D_f (mm)	300
Inner diameter of the rolled ring d_f (mm)	240
Wall thickness of the rolled ring b_f (mm)	30
Height of the rolled ring h_f (mm)	50
Radius of the main roll R_1 (mm)	100
Radius of the mandrel R_2 (mm)	50
Half of cone angle of the axial rolls θ ($^\circ$)	17.5
Rolling radius of the axial rolls R_{a1} (mm)	31.9
Friction coefficient μ	0.3
Initial temperature of the ring blank ($^\circ\text{C}$)	1000
Rotational speed of the main roll n_1 (r/min)	60
Rotational speed of the axial rolls n_a (r/min)	188.1

Table 1. The needed various data and parameters in the simulation case study

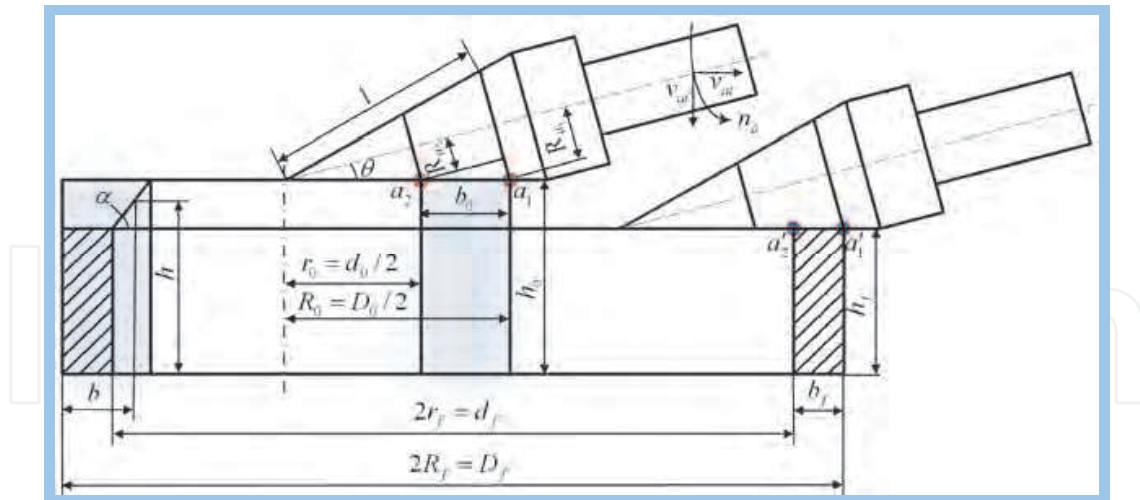

Fig. 7. Position variation of the upper conical roll before and after rolling

Another important work is to design the feed curves (paths) of the mandrel and the upper conical roll for the final determination of the calculation condition. Fig. 8 illustrates the feed curves versus rolling time of the mandrel and upper conical roll determined by the mathematical model of the developed steady forming condition as previously stated.

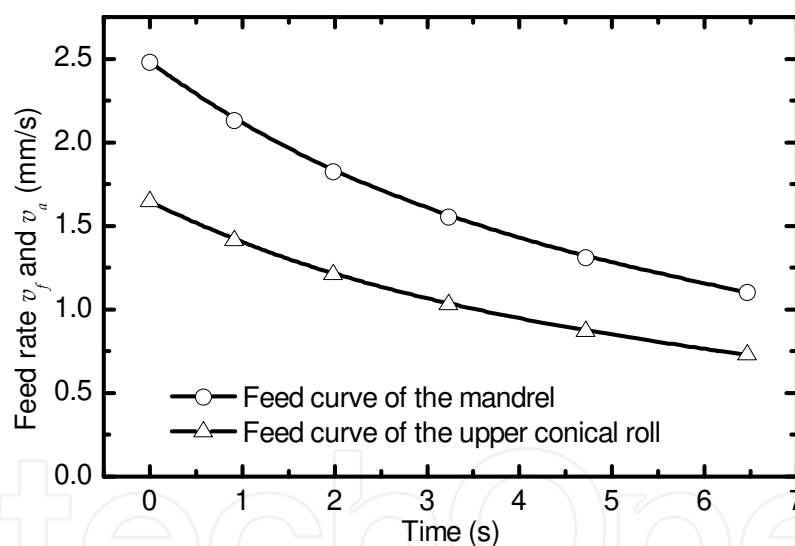

Fig. 8. Feed curves versus rolling time of the mandrel and upper conical roll

Based on the above calculation condition, a 3D-FE model of radial-axial ring rolling process is developed to predict the ring geometry evolution, stress field, strain field, temperature field, roll force and roll torque. The simulation results are discussed below.

4.2 Ring geometry evolution

Fig. 9 gives the deformed meshes of the ring blank with the rolling process progressing. It can be observed that the ring produces deformation of reduction in thickness, reduction in height, and extension in diameter during the radial-axial ring rolling process and the circularity of the rolled ring is good. And the simulation indicates that the overall rolling process has good stability.

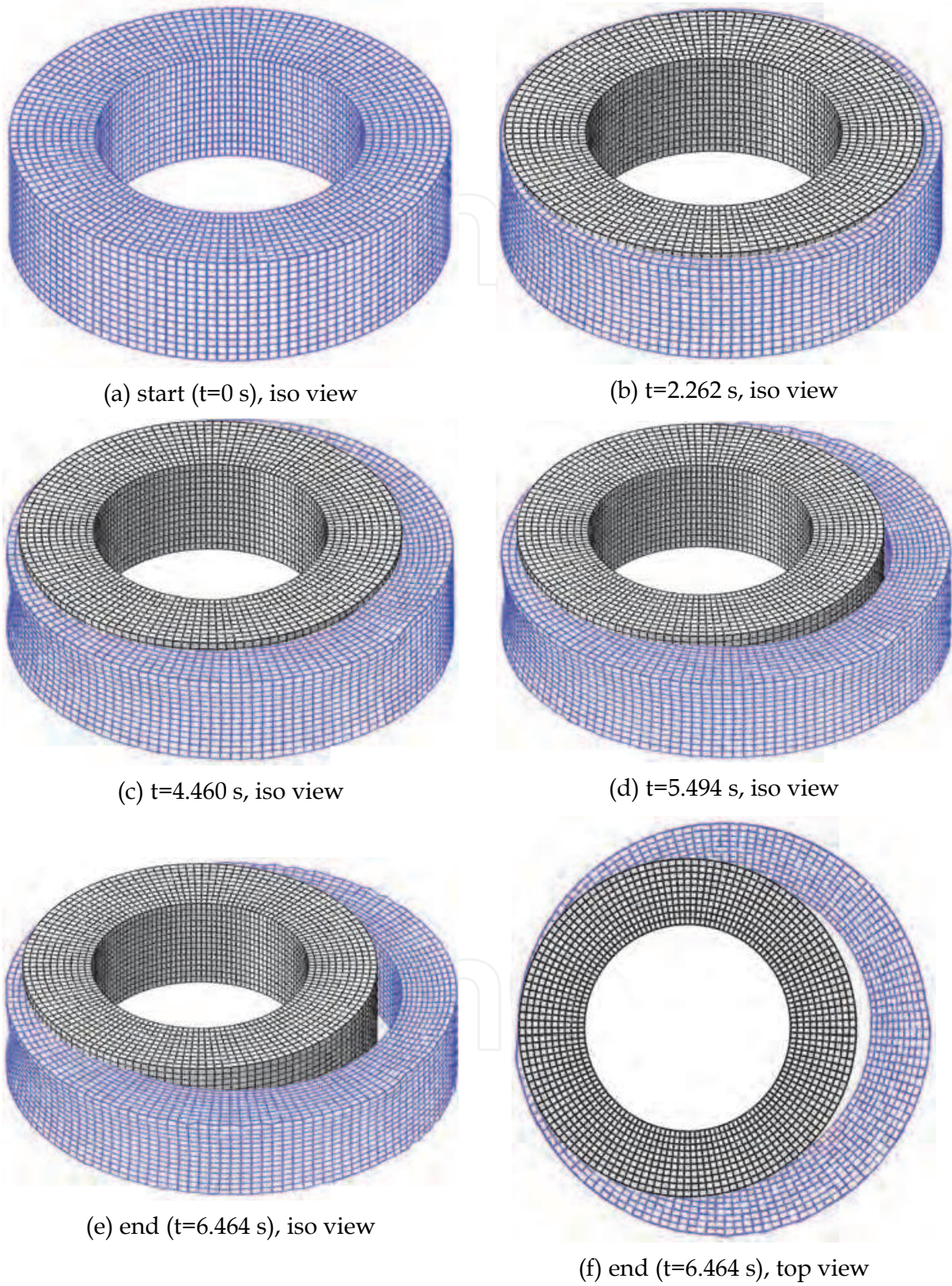

Fig. 9. Deformed meshes of the ring blank with the rolling process progressing

Observing the changes of deformed meshes of the ring, we can learn that the axial spread produced by the radial rolling is removed by the axial rolling of the axial conical rolls and the radial spread produced by the axial rolling is removed by the radial rolling between the main roll and mandrel. Just under the alternately multi-pass rolling in the radial and axial directions, the ring produces reductions of thickness and height and extension of diameter during the radial-axial ring rolling process.

4.3 Stress field

Fig. 10 gives the stress distribution contour of the rolled ring. It is seen that the maximum stress locates in the radial and axial deformation zones. And from the top view of the stress distribution contour, we can find that the radial and axial deformation zones are not on a diameter of the ring, although the radial and axial rolls are configured on a diameter of the ring. The arrow direction indicates the rotational direction of the ring. Just the deformation accumulation of ring materials in the radial and axial deformation zones leads to the reduction of cross-section and expansion of diameter of the ring blank.

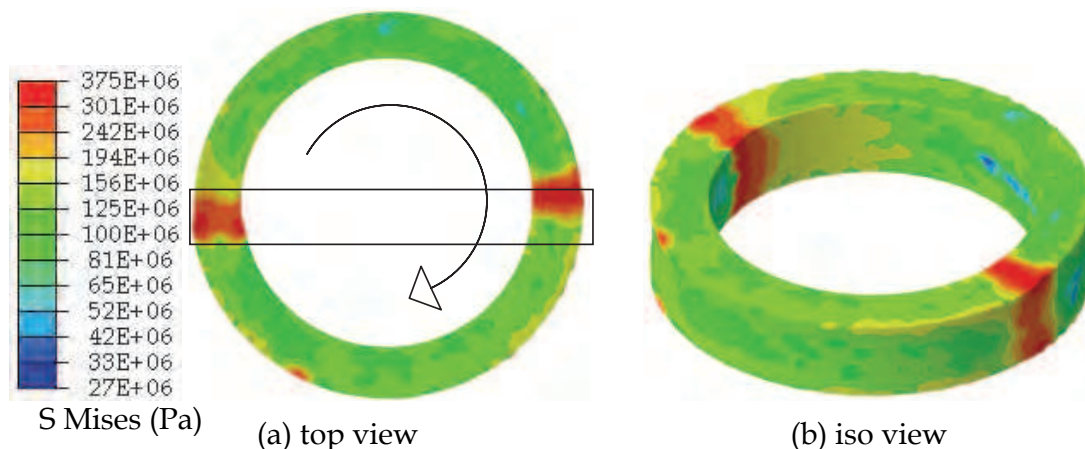

Fig. 10. Stress distribution contour of the rolled ring

4.4 Strain field

Fig. 11 shows equivalent plastic strain (PEEQ) distribution contour under different time during the radial-axial ring rolling process. It can be seen that: (1) at the early stage of the process, the plastic deformation basically only produces on the contact surfaces, i.e., the inner and outer surfaces and the upper and lower faces of the ring and then gradually extends to the centre of the ring with the process progressing; and (2) at the end of the process, the maximum plastic deformation locates on the corner close to the outer surface of the ring, while at the centre of the ring, there is an approximately circular ring zone in which the plastic strain is relatively small and much smaller than that on the maximum strain zone.

4.5 Temperature field

Fig. 12 shows temperature distribution contour under different time during the radial-axial ring rolling process. We can see that: (1) the minimum temperature zone locates in the centre area of the inner surface of the ring and the maximum temperature zone locates on the corner close to the outer surface of the ring; (2) in the minimum temperature zone, the

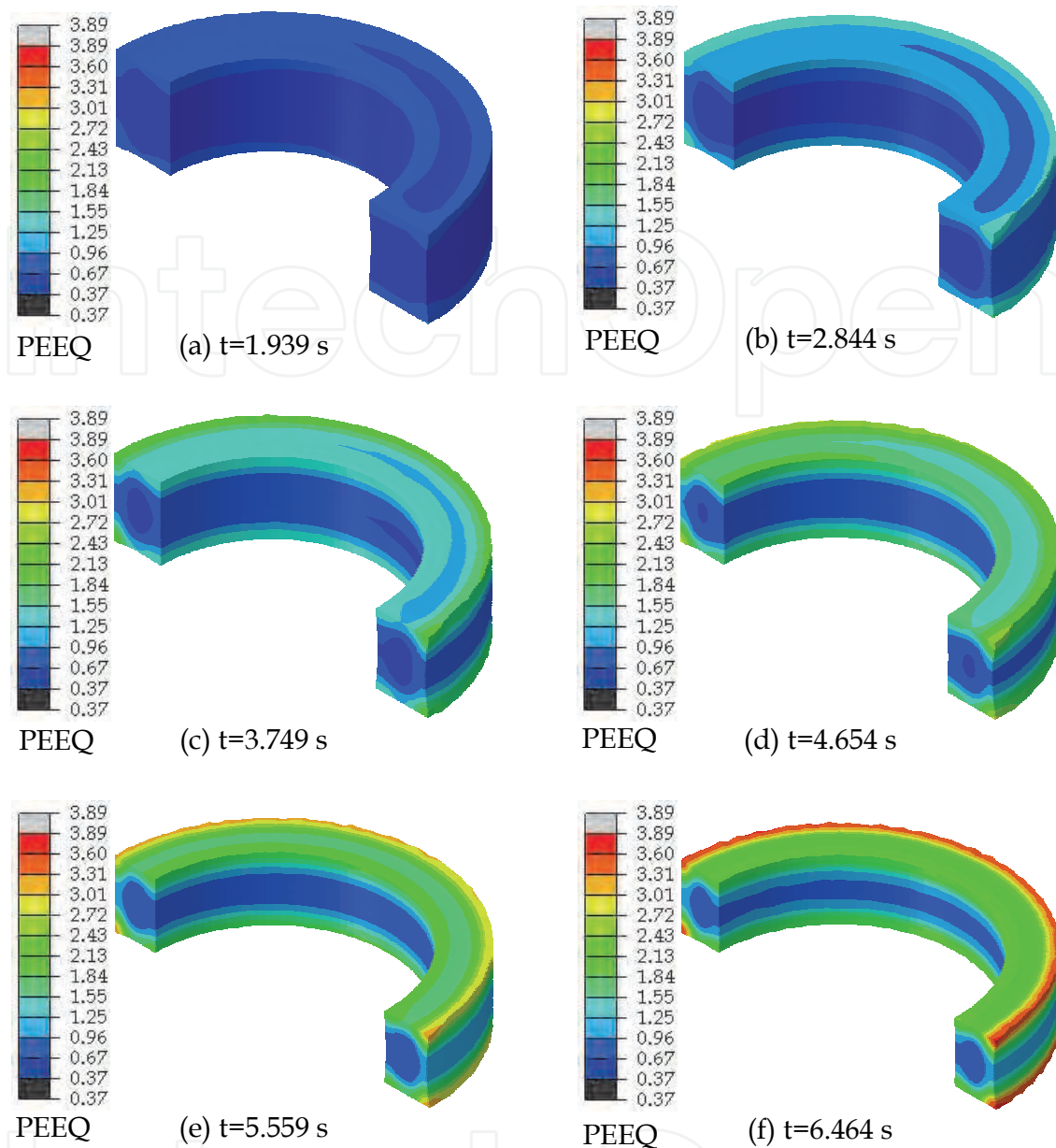

Fig. 11. Equivalent plastic strain (PEEQ) distribution contour under different time during the radial-axial ring rolling process

temperature decreases compared with the initial temperature of the ring due to contact heat dissipation; and (3) in the maximum temperature zone, the temperature increases compared with the initial temperature of the ring due to the heat generation of maximum plastic deformation.

4.6 Roll force and torque

Fig. 13 gives the variations of roll forces, which are measured by reaction forces on the mandrel, main roll, upper conical roll and lower conical roll, during radial-axial ring rolling process. From the figure it can be observed that: (1) the roll forces rapidly increase to maximum value at the early rolling stage and then gradually decrease at the steady rolling stage of the process; (2) the reaction force on the mandrel is greater than on the main roll, so

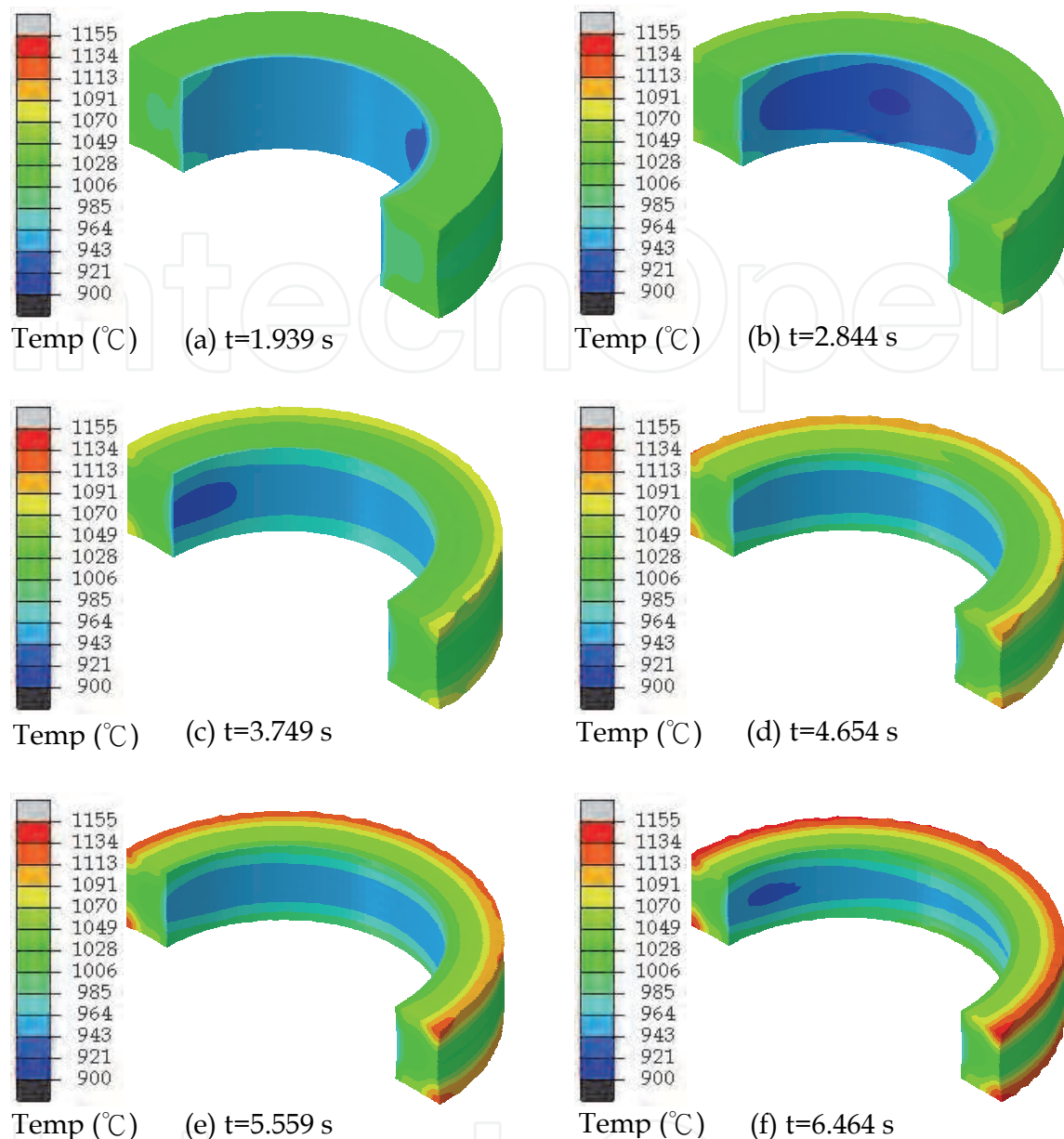

Fig. 12. Temperature distribution contour under different time during the radial-axial ring rolling process

the radial roll force should be determined by the reaction force on the mandrel for the selection of roll mill in consideration of safety for this simulation case; and (3) the reaction forces on the upper and lower conical rolls are basically equivalent, so the axial roll force can be determined by any one of them.

Fig. 14 shows the variation of the contact area between the ring and the rolls during the radial-axial ring rolling process. It is seen that the variation laws of the contact area during the process is similar to the ones of the roll forces shown in Fig.13. The size of the contact area between the ring and the rolls reflects the size of the deformation zone. The bigger is the contact area, the bigger is the deformation zone, and vice versa. So we can conclude from Fig.14 that the deformation zone in the radial pass is bigger than that in the axial pass for this simulation case.

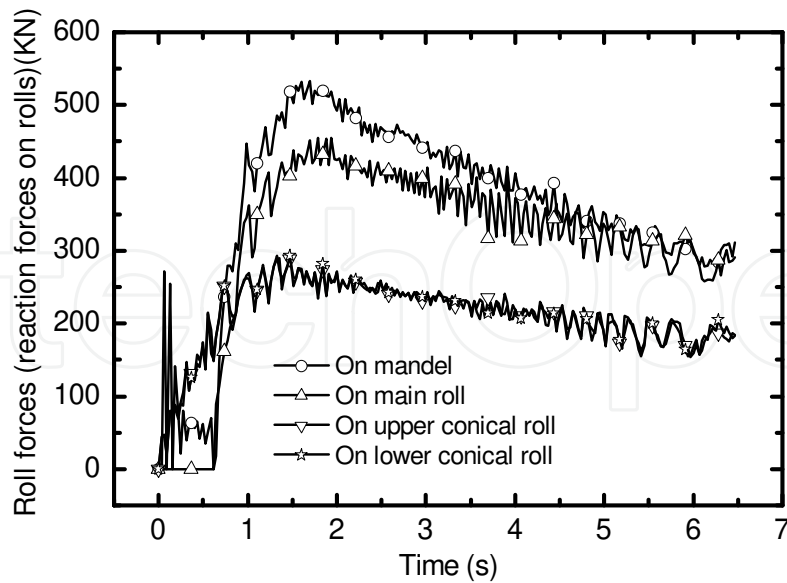

Fig. 13. Variation curves of roll forces during the radial-axial ring rolling process

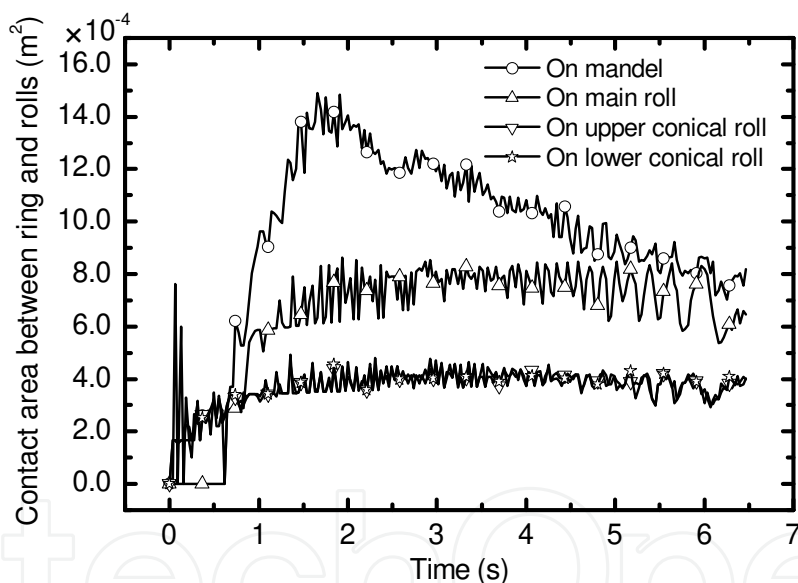

Fig. 14. The variation curves of the contact area between the ring and the rolls during the radial-axial ring rolling process

Fig. 15 gives the variations of the radial and axial roll torques, which are measured by reaction torques on the main roll and the axial upper and lower conical rolls, during radial-axial ring rolling process.

From Fig. 15 it can be observed that at the early stage, the variations of the radial and axial roll torques are relatively drastic and then tend towards stability. This demonstrates that the early rolling stage should be well-controlled for performing a successful radial-axial ring rolling operation. And the reaction torques of the upper and lower conical rolls have the same variation laws but reverse values because the axial conical rolls rotate in reverse direction during the rolling process.

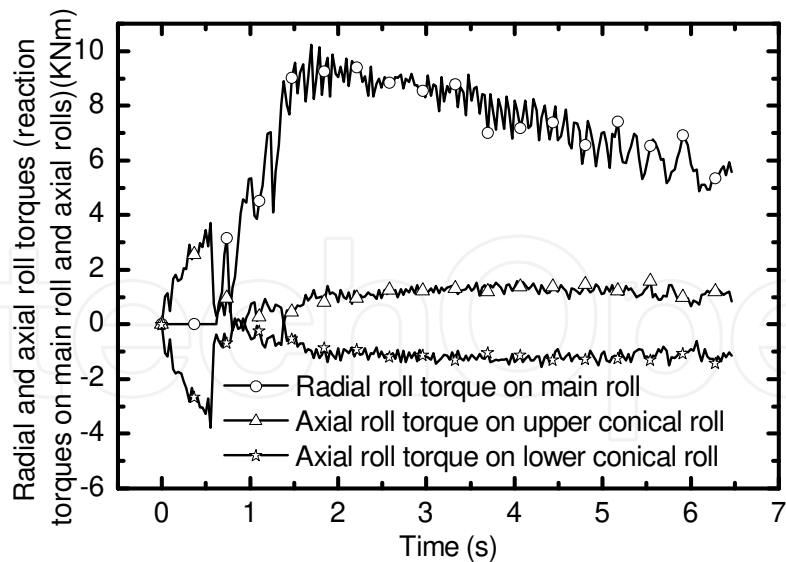

Fig. 15. Variation curves of the radial and axial roll forces during the radial-axial ring rolling process

5. Conclusion and future work

In consideration of the unique requirements of light weight, high precision, high performance, high reliability and high efficiency for the plasticity forming manufacture of various key aerospace components, the main challenges for the R&D of aerospace plasticity technology are summarized concisely. Facing the challenges, we have proposed a high-end research route for systematically and deeply investigating the aerospace plasticity technology, and pointed out that multi-field, multi-scale and entire process 3D-FE modeling, simulation and optimization has been an advanced and unique methodology for the rapid and inexpensive investigation of various aerospace plasticity technologies, especially for the R&D of new aerospace products and plasticity technologies for new materials.

As an application example of the proposed methodology for the investigation of aerospace plasticity technology, the high-end research route for radial-axial ring rolling technology has been given in consideration of the features of the process, which can be regarded as an overall planning for the implementation of various research tasks. Guided by the high-end research route, we first discussed the key FE modelling technologies such as geometry and assembly model, mesh design and optimization, material model, model of guide rolls control mechanism, contact and friction and determination of the paths of the rolls in detail, and then demonstrated the validation of the developed thermo-mechanical coupled 3D-FE model of radial-axial ring rolling process in terms of comparison of ring geometry and radial-axial roll forces with experiment.

Taking the coupled thermo-mechanical 3D-FE model as a virtual experimental platform, we carried out a simulation case study of radial-axial ring rolling process carefully. Some key simulation results, including ring geometry evolution, stress field, strain field, temperature field, roll forces and roll torques, are reported. The obtained simulation results are beneficial to gaining insight into the forming mechanism and laws of radial-axial ring rolling process and will provide important basis for the optimal design and steady control of the process.

However, the current studies carried out in this book chapter only basically realized multi-field (coupled thermo-mechanical) and entire process FE modelling and simulation. So,

according to the proposed high-end research route (as shown in Fig.3) and the key science problem proposed in introduction section of radial-axial ring rolling technology, the future work for the process is summarized as follows.

1. To develop microstructure evolution model of ring blank materials during radial-axial ring rolling process so as to numerically reveal the response of materials properties to the process;
2. To establish macro-micro coupled multi-scale FE model of radial-axial ring rolling process by embedding the microstructure evolution model of ring blank materials into the current coupled thermo-mechanical 3D-FE model of the process;
3. To reveal evolution mechanism of the geometry and microstructure of the ring blank by investigating macro plastic deformation and microstructure evolution behaviors, coupled effects of multi-factors, and macro and micro forming defects during radial-axial ring rolling process;
4. To establish optimization design and steady control method of radial-axial ring rolling process and to develop high-performance and precise radial-axial ring rolling technology.

6. Acknowledgment

The authors would like to thank the National Natural Science Foundation of China (50805120, 50935007), the National Basic Research Program of China ("973" Program) (2010CB731701), the Major National Science and Technology Special Project of China (2009ZX04014-074-03, 2010ZX04004-131-07), and the Research Fund of State Key Laboratory of Solidification Processing of China (KP200911) for the support given to this research.

7. References

- Allwood JM, Tekkaya AE & Stanistreet TF. (2005). The development of ring rolling technology. *Steel Research International*, Vol.76, No.2-3, (September 2005), pp. 111-120, ISSN 0177-4832
- Allwood JM, Tekkaya AE & Stanistreet TF. (2005). The development of ring rolling technology—Part 2: Investigation of process behaviour and production equipment. *Steel Research International*, Vol.76, No.7, (September 2005), pp. 491-507, ISSN 1611-3683
- Davey K & Ward MJ. (2003). An ALE approach for finite element ring-rolling simulation of profiled rings. *Journal of Materials Processing Technology*, Vol.139, No.1-3, (August 2003), pp. 559-566, ISSN 0924-0136
- Eruc E & Shivpuri R. (1992). A summary of ring rolling technology—I. Recent trends in machines, processes and production lines. *International Journal of Machine Tools and Manufacture*, Vol.32, No.3, (June 1992), pp. 379-98, ISSN 0890-6955
- Eruc E & Shivpuri R. (1992). A summary of ring rolling technology—II. Recent trends in process modeling, simulation, planning and control. *International Journal of Machine Tools and Manufacture*, Vol. 32, No.3, (June 1992), pp. 399-413, ISSN 0890-6955
- Forouzan MR, Salimi M, Gadala MS & Aljawi AA. (2003). Guide roll simulation in FE analysis of ring rolling. *Journal of Materials Processing Technology*, Vol.142, No.1, (November 2003), pp. 213-223, ISSN 0924-0136

- Forouzan MR, Salimi M & Gadala MS. (2003). Three-dimensional FE analysis of ring rolling by employing thermal spokes method. *International Journal of Mechanical Sciences*, Vol.45, No.12, (December 2003), pp. 1975-1998, ISSN 0020-7403
- Fan XG, Yang H, Sun ZC, & Zhang DW. (2010). Effect of deformation inhomogeneity on the microstructure and mechanical properties of large-scale rib – web component of titanium alloy under local loading forming. *Materials Science and Engineering A*, Vol.527, No.21-22, (August 2010), pp. 5391-5399, ISSN 0921-5093
- Guo LG, Yang H & Zhan M. (2005). Research on plastic deformation behaviour in cold ring rolling by FEM numerical simulation. *Modelling and Simulation in Materials Science and Engineering*, Vol.13, No.7, (October 2005), pp. 1029-1046, ISSN 0965-0393
- Guo LG & Yang H. (2011). Towards a steady forming condition for radial-axial ring rolling. *International Journal of Mechanical Sciences*, Vol.53, No.4, (April 2011), pp. 286-299, ISSN 0020-7403
- Hawkyard J B, Johnson W, Kirkland J & Appleton E. (1973). Analyses for roll force and torque in ring rolling, with some supporting experiments. *International Journal of Mechanical Sciences*, Vol. 15, No.11, (November 1973), pp. 873-893, ISSN 0020-7403
- Hahn YH & Yang DY. (1994). UBET analysis of the closed-pass ring rolling of rings having arbitrarily shaped profiles. *Journal of Materials Processing Technology*, Vol. 40, No.3-4, (January 1994), pp. 451-463, ISSN 0924-0136
- Hua L, Pan LB & Lan J. (2009). Research on the ring stiffness condition in radial-axial ring rolling. *Journal of Materials Processing Technology*, Vol.209, No.5, (March 2009), pp. 2570-2575, ISSN 0924-0136
- Johnson W & Needham G. (1968). Experiments on ring rolling. *International Journal of Mechanical Sciences*, Vol.10, No.2, (February 1968), pp. 95-113, ISSN 0020-7403
- Joun MS, Chung JH & Shivpuri R. (1998). An axisymmetric forging approach to preform design in ring rolling using a rigid-viscoplastic finite element method. *International Journal of Machine Tools and Manufacture*, Vol.38, No.10-11, (October 1998), pp. 1183-1191, ISSN 0890-6955
- Jong TY, Jeoung HK, Nho KP, Seung SC & Chong SL. (2007). Ring-rolling design for a large-scale ring product of Ti-6Al-4V alloy. *Journal of Materials Processing Technology*, Vol. 187-188, No. 12, (June 2007), pp. 747-751, ISSN 0924-0136
- Kim N, Machida S & Kobayashi S. (1990). Ring rolling process simulation by the three dimensional finite element method. *International Journal of Machine Tools and Manufacture*, Vol.30, No.4, (1990), pp. 569-577, ISSN 0890-6955
- Kang BS & Kobayashi S. (1991). Preform design in ring rolling processes by the three-dimensional finite element method. *International Journal of Machine Tools and Manufacture*, Vol.31, No.1, (1991), pp. 139-151, ISSN 0890-6955
- Lugora CF & Bramley AN. (1987). Analysis of spread in ring rolling. *International Journal of Mechanical Sciences*, Vol.29, No.2, (1987), pp. 149-157, ISSN 0020-7403
- Liu YL, Yang H, Zhan M & Fu ZX. (2002). A study of the influence of the friction conditions on the forging process of a blade with a tenon. *Journal of Materials Processing Technology*, Vol.123, No.1, (April 2002), pp. 42-46, ISSN 0924-0136
- Li LY, Yang H, Guo LG & Sun ZC. (2008). A control method of guide rolls in 3D-FE simulation of ring rolling. *Journal of Materials Processing Technology*, Vol.205, No.1-3, (August 2008), pp. 99-110, ISSN 0924-0136

- Li H, Yang H, Zhan M & Kou YL. (2010). Deformation behaviors of thin-walled tube in rotary draw bending under push assistant loading conditions. *Journal of Materials Processing Technology*, Vol.210, No.1, (January 2010), pp. 143-158, ISSN 0924-0136
- Mamalis AG, Hawkyard JB & Johnson W. (1975). Cavity formation in rolling profiled rings. *International Journal of Mechanical Sciences*, Vol. 17, No.11-12, (1975), pp. 669-672, ISSN 0020-7403
- Moon HK, Lee MC & Joun MS. (2008). Predicting polygonal-shaped defects during hot ring rolling using a rigid-viscoplastic finite element method. *International Journal of Mechanical Sciences*, Vol.50, No.2, (February 2008), pp. 306-314, ISSN 0020-7403
- Wang ZW, Zeng SQ, Yang XH & Cheng C. (2007). The key technology and realization of virtual ring rolling. *Journal of Materials Processing Technology*, Vol.182, No.1-3, (February 2007), pp. 374-381, ISSN 0924-0136
- Wang M, Yang H, Sun ZC & Guo LG. (2009). Analysis of coupled mechanical and thermal behaviors in hot rolling of large rings of titanium alloy using 3D dynamic explicit FEM. *Journal of Materials Processing Technology*, Vol.209, No.7, (April 2009), pp. 3384-3395, ISSN 0924-0136
- Yang DY, Kim KH & Hawkyard JB. (1991). Simulation of T-section profile ring rolling by the 3-D rigid-plastic finite element method. *International Journal of Mechanical Sciences*, Vol.33, No.7, (1991), pp. 541-550, ISSN 0020-7403
- Yang H, Zhan M & Liu YL. (2002). A 3D rigid-viscoplastic FEM simulation of the isothermal precision forging of a blade with a damper platform. *Journal of Materials Processing Technology*, Vol.122, No.1, (March 2002), pp. 45-50, ISSN 0924-0136
- Yang H, Zhan M, Liu YL, Xian FJ, Sun ZC, Lin Y & Zhang XG. (2004). Some advanced plastic processing technologies and their numerical simulation. *Journal of Materials Processing Technology*, Vol. 151, No.1-3, (April 2004), pp. 151:63-69, ISSN 0924-0136
- Yang H, Wang M, Guo LG, & Sun ZC. (2008). 3D coupled thermo-mechanical FE modeling of blank size effects on the uniformity of strain and temperature distributions during hot rolling of titanium alloy large rings. *Computational Materials Science*, Vol.44, No.2, (December 2008), pp. 611-621, ISSN 0927-0256
- Yang H, Huang L, & Zhan M. (2010). Coupled thermo-mechanical FE simulation of the hot splitting spinning process of magnesium alloy AZ31. *Computational Materials Science*, Vol.47, No.3, (January 2010), pp. 857-866, ISSN 0927-0256
- Yang H, Li H, & Zhan M. (2010). Friction role in bending behaviors of thin-walled tube in rotary-draw-bending under small bending radii. *Journal of Materials Processing Technology*, Vol.210, No.15, (November 2010), pp. 2273-2284, ISSN 0924-0136
- Zhan M, Yang H, Huang L & Gu RJ. (2006). Springback analysis of numerical control bending of thin-walled tube using numerical-analytic method. *Journal of Materials Processing Technology*, Vol.177, No.1-3, (July 2006), pp. 197-201, ISSN 0924-0136
- Zhan M, Yang H, Zhang JH, Xu YL & Ma F. (2007). 3D FEM analysis of influence of roller feed rate on forming force and quality of cone spinning. *Journal of Materials Processing Technology*, Vol.187-188, (June 2007), pp. 486-491, ISSN 0924-0136
- Zhou G, Hua L, Lan J & Qian DS. (2010). FE analysis of coupled thermo-mechanical behaviors in radial-axial rolling of alloy steel large ring. *Computational Materials Science*, Vol.50, No.1, (November 2010), pp. 65-76, ISSN 0927-0256

Zhou G, Hua L & Qian DS. (2011). 3D coupled thermo-mechanical FE analysis of roll size effects on the radial-axial ring rolling process. *Computational Materials Science*, Vol. 50, No.3, (January 2011), pp. 911-924, ISSN 0927-0256

IntechOpen

IntechOpen

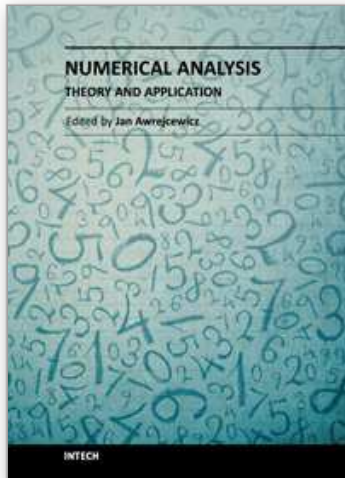

Numerical Analysis - Theory and Application

Edited by Prof. Jan Awrejcewicz

ISBN 978-953-307-389-7

Hard cover, 626 pages

Publisher InTech

Published online 09, September, 2011

Published in print edition September, 2011

Numerical Analysis – Theory and Application is an edited book divided into two parts: Part I devoted to Theory, and Part II dealing with Application. The presented book is focused on introducing theoretical approaches of numerical analysis as well as applications of various numerical methods to either study or solving numerous theoretical and engineering problems. Since a large number of pure theoretical research is proposed as well as a large amount of applications oriented numerical simulation results are given, the book can be useful for both theoretical and applied research aimed on numerical simulations. In addition, in many cases the presented approaches can be applied directly either by theoreticians or engineers.

How to reference

In order to correctly reference this scholarly work, feel free to copy and paste the following:

Lianggang Guo and He Yang (2011). Numerical Modelling and Simulation of Radial-Axial Ring Rolling Process, Numerical Analysis - Theory and Application, Prof. Jan Awrejcewicz (Ed.), ISBN: 978-953-307-389-7, InTech, Available from: <http://www.intechopen.com/books/numerical-analysis-theory-and-application/numerical-modelling-and-simulation-of-radial-axial-ring-rolling-process>

INTECH
open science | open minds

InTech Europe

University Campus STeP Ri
Slavka Krautzeka 83/A
51000 Rijeka, Croatia
Phone: +385 (51) 770 447
Fax: +385 (51) 686 166
www.intechopen.com

InTech China

Unit 405, Office Block, Hotel Equatorial Shanghai
No.65, Yan An Road (West), Shanghai, 200040, China
中国上海市延安西路65号上海国际贵都大饭店办公楼405单元
Phone: +86-21-62489820
Fax: +86-21-62489821

© 2011 The Author(s). Licensee IntechOpen. This chapter is distributed under the terms of the [Creative Commons Attribution-NonCommercial-ShareAlike-3.0 License](#), which permits use, distribution and reproduction for non-commercial purposes, provided the original is properly cited and derivative works building on this content are distributed under the same license.

IntechOpen

IntechOpen