

# We are IntechOpen, the world's leading publisher of Open Access books Built by scientists, for scientists

**4,800**

Open access books available

**122,000**

International authors and editors

**135M**

Downloads

Our authors are among the

**154**

Countries delivered to

**TOP 1%**

most cited scientists

**12.2%**

Contributors from top 500 universities



**WEB OF SCIENCE™**

Selection of our books indexed in the Book Citation Index  
in Web of Science™ Core Collection (BKCI)

Interested in publishing with us?  
Contact [book.department@intechopen.com](mailto:book.department@intechopen.com)

Numbers displayed above are based on latest data collected.

For more information visit [www.intechopen.com](http://www.intechopen.com)



# The Declarative Framework Approach to Decision Support for Constrained Search Problems

Paweł Sitek and Jarosław Wikarek  
*Technical University of Kielce  
Poland*

## 1. Introduction

Decision making supported by task-oriented software tools plays a pivotal role in modern enterprises; the commercially available ERP (Enterprise Resource Planning) systems are not able to respond in an interactive on-line/real-time mode.

A new generation of DSS (Decision Support System) that enable a fast prototyping of constrained search problems (e.g. layout planning, production routing, batch-sizing, scheduling, transportations, distributions, flow in supply chain, ) is needed. In that context for constrained search problems, the CLP (Constraint Logic Programming) (Apt et al, 2007) techniques allowing declarative representation of a decision making problem provide quite an attractive alternative. Constrained search problems are usually characterized by many types of constraints, which make them unstructured and difficult to solve (NP-complete). Traditional mathematical programming approaches are deficient because their representation of constraints is artificial (using 0-1 variables).

This paper discusses declarative framework for decision support in outbound logistic (Fig.1) of SCM (Supply Chain Management) (Simchi-Levi et al., 2003) (Douglas et al., 2000) as an example of use. It will focus on potential areas and processes where decision support or optimization is reasonable, and it will also introduce the concept and an outline of decision support system structures for the SCM in the form of an additional layer of information. The solutions are developed not to substitute, but to be integrated with SCM and with the broader sense Enterprise Resource Planning (ERP) solutions.

## 2. Supply chain management

Increasing competition in today's global market and the heightened expectations of customers have forced enterprises to consider their supply chains more carefully. A supply chain (SC) can be considered as a network of stages that represent functionalities (including suppliers, manufacturers, distributors, and retailers) that must be provided to convert raw materials into the specified end-products and deliver these end-products to retailers or customers (Simchi-Levi et al., 2003). A supply chain system (SCS) is usually composed of a series of organizations and/or independent companies. A supply chain system is the set of approaches utilized to efficiently integrate suppliers, manufacturers, warehouses,

distribution centers, retailers and ultimately the customers so that merchandise is produced and distributed at the right quantities to the right locations and at right times, in order to minimize the total system cost while satisfying the service level requirements. The main operational activities of the supply chain system include:

1. Raw materials: sales forecasting, inventory planning, and purchasing, transportation between suppliers and manufacturers – Suppliers.
2. Work-in-process: processing and managing efficiently the inventories of partially completed products inside the manufacturing plants – Manufacturers.
3. Finished goods: warehousing of finished goods inventory, servicing the customers, and transporting materials among the wholesalers, retailers, and customers. These parts reflect the basic movement of goods, services, and information through an integrated system-Distributors, Retailers, Customers.

A supply chain is characterized by a forward flow of goods and a backward flow of information (Fig.1). Commonly, a supply chain is comprised of two basic business processes:

- material management
- physical distribution

Increasingly, the management of multiple relationships across the supply chain is being referred to as supply chain management (SCM) (Douglas et al., 2000).

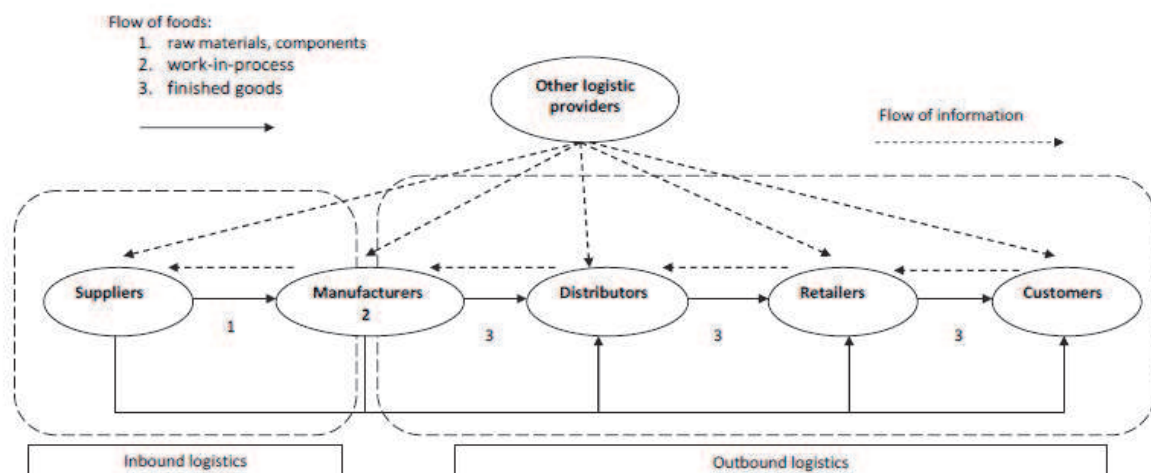

Fig. 1. The supply chain process.

The field of supply chain management uses an increasing set of tools and techniques to effectively coordinate the decision-making process.

## 2.1 Integration in SCM

Supply-chain management is one of the leading business process re-engineering, cost-saving and revenue enhancement strategies in use today. Effective integration of a supply chain can save money, simultaneously improving customer service and reducing inventories etc.. Supply chains have been more or less integrated to some extent – albeit on a low scale – as a whole, or in parts. Integration, if done at all, has been mostly done in patches throughout the supply chain. In many cases, this has been driven more by the need to survive and improvise, than by the willingness to improve and advance further. Integration can be

carried out for different aspects of a company's supply chain. According to (Shapiro, 2001), there are four dimensions to integration.

- **Functional integration:** It relates to the different functions performed by the organization, for example, purchasing, location, manufacturing, warehousing, and transportation.
- **Spatial integration:** This type of integration is done over a target group of supply chain entities - vendors, manufacturing facilities, warehouses, and markets.
- **Hierarchical integration:** It refers to integration of the overlapping decisions in the strategic, tactical, and operational planning horizons. For example, it is important to strategically locate the manufacturing facilities with respect to the vendors to help in optimizing the supply policies.
- **Enterprise integration:** It emphasizes the importance of strategic and tactical planning decisions like, integration of supply chain management with demand management and financial management to maximize the revenues and also to increase long-term returns on investments.

## 2.2 Decision support in SCM

Several issues need to be considered while building a decision support system (DSS) for managing the supply chain. A manufacturer will find offers to sell the materials they need as well as offers to purchase goods they produce. All this information will supplement the data already in the firm's ERP (Enterprise Resource Planning) system, which includes inventory, customer orders, and the state of the manufacturing schedule, distribution etc.. Taken together, these data can enable much better decisions as to what products to make, what raw materials to purchase, what orders to accept, how to distribute etc.. This paper will focus on logistic where decision support or optimization is very reasonable. A logistic network should maximize profits and provide a least total cost system, while also achieving desired customer service level. The models of outbound logistics are often mixed-integer programming (MIP) formulation that seek to achieve the following:

- Inventory optimization and reduction at the warehouse (the factory warehouse) or/and distribution center;
- Load optimization for transportation from the factory warehouse to the delivery locations (i.e., DCs, bins, plants, and direct-delivery (DD) customers, Distribution Centers(DC)), while allowing direct (plant-to-store) and interplant shipments;
- Flow optimization throughout the entire outbound supply chain.

A number of quantitative models use mixed-integer programming (MIP) to solve the supply chain optimization problems. One of the first attempts was done by Geoffrion and Graves [4], where a MIP model (Frühwirth & Slim, 2003) (Vanderbei, 2008) (Schrijver, 1998) (Cornelis et al., 2006) was formulated for the multicommodity location problem. This seminal research involved the determination of distribution center (DC) locations, their capacities, customer zones and transportation flow patterns for all commodities. A solution to the location portion of the problem was presented, based on Bender's Decomposition (BD). The transportation portion of the problem is decoupled into a separate classical transportation problem for each commodity. Their approach shows a high degree of effectiveness and advantage of using BD over branch-and-bound. The technique has been applied on a real problem to test its performance. However, the computational requirements and technical resources required for its implementation make it a difficult choice in classical MIP tools.

### 3. The concept of decision support system structures – declarative approach

While imperative models specify exactly how things have to be done, declarative approaches only focus on the logic that governs the interplay of actions in the process by describing (1) the activities that can be performed, as well as (2) constraints prohibiting undesired behavior. Imperative models take an 'inside-to-outside' approach by requiring all execution alternatives to be explicitly specified in the model. Declarative models, in turn, take an 'outside-to-inside' approach: constraints implicitly specify execution alternatives as all alternatives have to satisfy the constraints (Pesic, 2008).

The concept of decision support system for managing supply chain can be regarded as an additional information layer, which contains both elements of the structure and functional information.

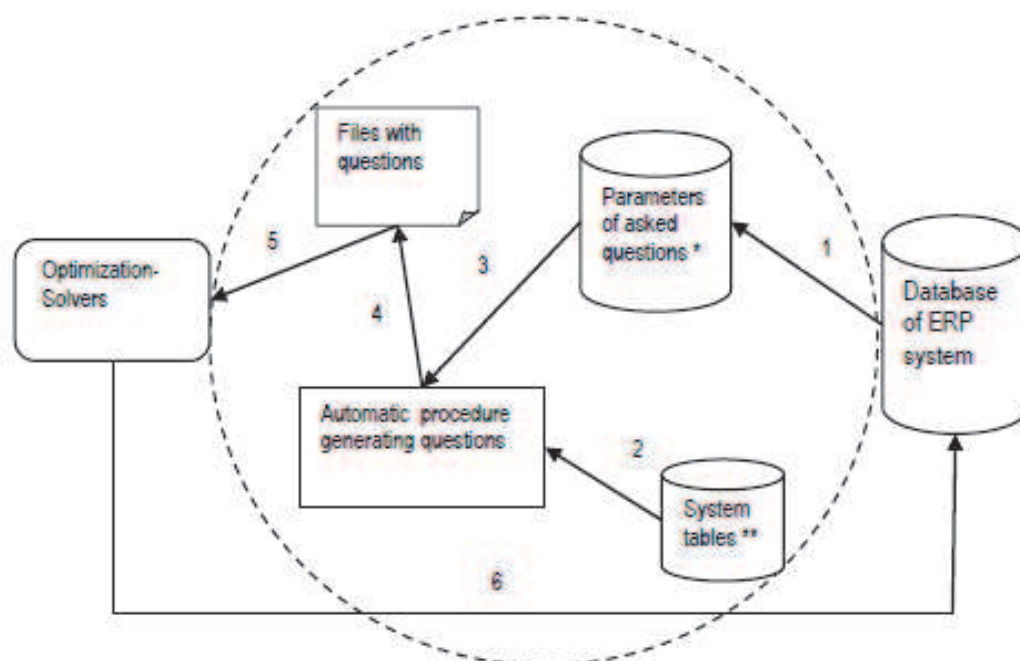

Fig. 2. The simplified schema of the basic structures and functionality for decision support system as an additional information layer

Decisions in the presented system are the answers to specific questions. Questions are implemented as predicates in CLP. The contribution of this concept is largely automated implementation of questions as predicates CLP by appropriate entries in the database.

The parts of the proposed database structure for the decision support system are presented in Table 1, Table 2 and ERD (Entity Relationship Diagram)-Fig.3, Fig.4, Fig.5. The basic functional structure, components of the system and method of operation are shown in Fig.1. Ask a question launches a sequence of events. The most important of them subject to the chronology and numbers (Fig.2) have been presented below.

1. Mapping-completion of the data structures of questions based on the ERP database (Table 2).
2. Loading information on the structure and functions of questions from the system tables (Table 1)(Fig.3).

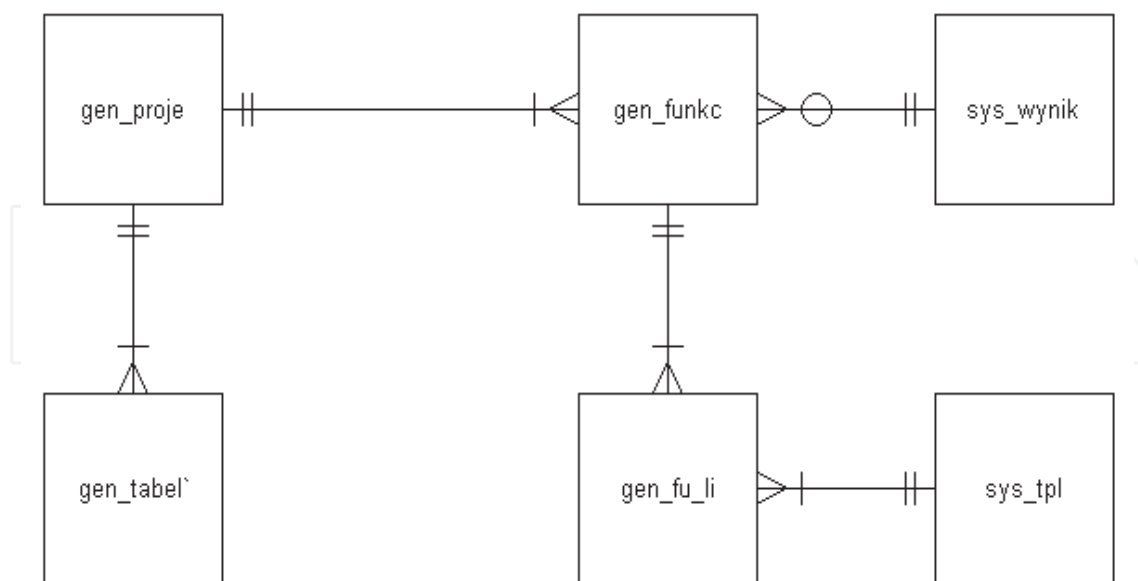

Fig. 3. The part of ERD (simplified Martin’s notation) diagram for the system tables.

Table name <i>description</i>	Column name	Key	Column description
sys_templ -Types of line	kd_idlin	pk	ID line type
	id_nazwa		The name of the line type
sys_wynik -Results	kd_wynik	pk	ID result
	id_opis_		Description of the type of result
gen_proje <i>Projects</i>	kd_idpro	pk	ID project
	id_nazwa		The name of the project
	id_skrot		Short name
	id_opis_		Description of the project
gen_funkc- <i>Functions during the handling of the project</i>	kd_idpro	pk(fk)	ID project
	kd_idfun	pk	ID function
	fd_wynik	fk	Id result
	id_opis_		Description of the function
gen_fu_li - <i>The function codes during the operation of the project</i>	kd_idpro	pk(fk)	ID project
	kd_idfun	pk(fk)	ID function
	kd_id_ko	pk	The line number
	fd_idlin	fk	ID line type
	id_dana_		The line code
gen_tabel - <i>Tables of the project</i>	kd_idpro	pk(fk)	ID project
	kd_id_ta	pk	The name of the table in the project.
	id_id_al		Table name
	id_opis_		Table description

Table 1. System tables - the part of the additional information layer.

3. Loading data for questions from questions parameters tables.
4. Generating questions in the form of text files in the correct format/meta-language/ of the optimization program.
5. Sending files with questions to the optimization program.
6. Recording the results obtained/decisions/in the database.  
(question=decision making model)

The functionality of the layer mapped by the dotted line in Fig.2.

Decision can be interpreted as a response to the properly formulated question that meets the existing constraints.

As an illustrative example of using DSS (the questions in the form of the CLP predicates), the optimization in distribution centers has been presented. Philosophy and structure of the proposed decision support system may have a place for all areas of SCM, ERP (Moon, 2007) etc.

#### 4. Optimization in distribution centers

Centralization of distribution reduces the number of transactions compared to the number of transactions without a central distribution. The supplier does not need to send parcel to multiple recipients, but sends one to a dedicated distribution center. Similarly, the recipient does not need to take many items from many suppliers, but receives the bulk of the load from the distribution center.

Reducing the number of transactions between suppliers and customers helps reduce the average time of delivery and the costs of these transactions. The centralized distribution in the form of distribution centers results in an incomparably greater opportunity to optimize resources, processes, costs, etc.

Potential areas of decision support and optimization for the exemplified distribution center depends on the decision level:

**Strategic level** - (number and location of the distribution center depots, the choice of product groups, the territorial constraints of the area serviced by the distribution center, transportation problems etc.);

**Tactical level** - (structure and size of fleet vehicles, periodic change of route plans, etc.);

**Operational level** - (completion of contracts , optimization of loading, dynamic route planning, inventory management, high storage, allocation of pallets etc.).

It should be noted that these effects are achieved at the cost of what is happening inside the distribution center. It is there where the received goods must be unloaded, reassembled and uploaded for transport to customers. Therefore the issue of cost optimization is not obvious for every lot size or for any batch of goods.

##### 4.1 Problem of allocation of pallets

Problems of optimization and decision support in a distribution center play a key role at the operational level, where decisions must be taken daily or even several times a day.

The method and quality of such decisions have the greatest impact on the operation of the distribution center and as a result on its effectiveness.

It is at the operational level where rapid and effective assistance should be provided to operators who manage the warehouse activities, including palletizing and forwarding. One of several problems that must be solved every day in distribution centers (e.g. wholesale food, liquor, etc.) is the problem of allocation of pallets.

For example, at the distribution center of FMCG (Fast Moving Consumer Goods), pallets distribution process for the end customer begins with the storage document created by the Sales Department on the basis of a client's order.

The storage document contains general information about the contract, including the division into pallets. Based on this information picking and packing is done. The arrangement of individual goods in the storage document warehouse is optimal against the AVG route. Then the pallets are stored in the forwarding area of the warehouse. The allocation of pallets to each route and then the way of loading the pallets on trucks are decided by dispatchers on the basis of their experience. The method of loading (loading order) pallets on the truck is the deterministic process that depends on the route. But the allocation of pallets to the route and the appropriate type of truck is not the deterministic process.

In the problem of allocation of pallets, the main asked question is: What is the minimum cost of supply pallets? Answer to this question in this case the solution of mathematical model allows for answers to other questions. These are important questions from a practical point of view. The most important ones are: Which route will be operated? What is the number of courses assigned to each route? What type of trucks will be used? How much will the supplies for each point?

Symbol	Description
<b>Indices</b>	
$j$	delivery point $j \in J = \{1, \dots, N\}$
$i$	route $i \in I = \{1, \dots, M\}$
$l$	truck type $l \in L = \{1, \dots, O\}$
<b>Input Parameters</b>	
$Z_j$	demand for pallets at delivery point $j$ ( $j=1..N$ ).
$D_{ji}$	$\begin{cases} 1 & \text{if delivery point } j \text{ belongs to route } i \\ 0 & \text{otherwise} \end{cases}$ for ( $j=1..N$ ), ( $i=1..M$ )
$K_l$	capacity of truck $l$ (pallets) ( $l=1..O$ )
$U_l$	feasible number of routes for truck type $l$ ( $l=1..O$ ).
$W_l$	feasible length of route for truck type $l$ ( $l=1..O$ ).
$C_{li}$	the cost of route $i$ ( $i=1..M$ ) by the truck type $l$ ( $l=1..O$ )
$E_{li}$	the time course of truck type $l$ ( $l=1..O$ ) on the route $i$ ( $i=1..M$ )
$B_{j,i,l}$	the cost of delivery to delivery point $j$ ( $j=1..N$ ) on the route $i$ ( $i=1..M$ ) by truck type $l$ ( $l=1..O$ ). (Variable depending on the number of pallets).
<b>Decision Variables (Integer)</b>	
$X_{j,i,l}$	part of the demand for pallets for the delivery point $j$ ( $j=1..N$ ), implemented on the route $i$ ( $i=1..M$ ) supported by the truck type $l$ ( $l=1..O$ )
$Y_{i,l}$	number of courses truck type $l$ ( $l=1..O$ ) on the route $i$ ( $i=1..M$ )

Table 2. The indices, input parameters and the decision variables for optimization model.



A mathematical model for the main asked question has been formulated in the form of Mixed Integer Programming (MIP) problem (Schrijver, 1998). The cost of transport, which as a result of optimization is minimized has been adopted as an objective function. Decision variables of the model ( $X_{jil}$ ) are the variables determining the number of pallets to be delivered to the delivery point of a route chosen by the truck.

Constraints of the mathematical model (1) to (6) can be interpreted as follows. Constraint (1) ensures that every requirement is met, that is, that each delivery point receives as many pallets of goods as they ordered. Constraint (2) ensures the fulfillment of the transfer for it restricts quantitatively the loading on the truck to its potential capacity and the number of courses. A further constraint (3) ensures that the number of courses for the given type of truck is not exceeded. Constraint (4) enforces the allocation of vehicles to these routes where cargo has already been allocated in the form of a certain number of pallets, i.e. the value of decision variable  $X_{jil}$  is different from zero. Constraint (6) refers to a timely delivery. Constraint (5) ensures that all the decision variables are restricted to be integers. The presented model also takes into account the dynamic optimization of routes. To this end a delivery points that belong to each route has been introduced, and the decision variable determining the volume of demand  $X_{jil}$  depends on specific points of supply.

The indices, input parameters and the decision variables for this model have been shown in Table 2.

**Objective Function** - minimize transportation costs:

$$\sum_{i=1}^M \sum_{l=1}^O Y_{i,l} * C_{i,l} + \sum_{j=1}^N \sum_{i=1}^M \sum_{l=1}^O X_{j,i,l} * B_{j,i,l}$$

**Subject to:**

$$\sum_{i=1}^M \sum_{l=1}^O X_{j,i,l} * D_{j,i} = Z_j \text{ for } j = 1..N \quad (1)$$

$$\sum_{j=1}^N \sum_{i=1}^M X_{j,i,l} \leq U_l * K_l \text{ for } l = 1..O \quad (2)$$

$$\sum_{i=1}^M Y_{i,l} \leq K_l * Y_{i,l} \text{ for } l = 1..O, \quad (3)$$

$$\sum_{j=1}^N X_{j,i,l} \leq K_l * Y_{i,l} \text{ for } i = 1..M, l = 1..O, \quad (4)$$

$$X_{j,i,l} \in C \text{ for } j = 1..N, i = 1..M, l = 1..O,$$

$$Y_{i,l} \in C \text{ for } i = 1..M, l = 1..O, \quad (5)$$

$$\sum_{i=1}^M E_{i,l} Y_{i,l} \leq W_l \text{ for } l = 1..O \quad (6)$$

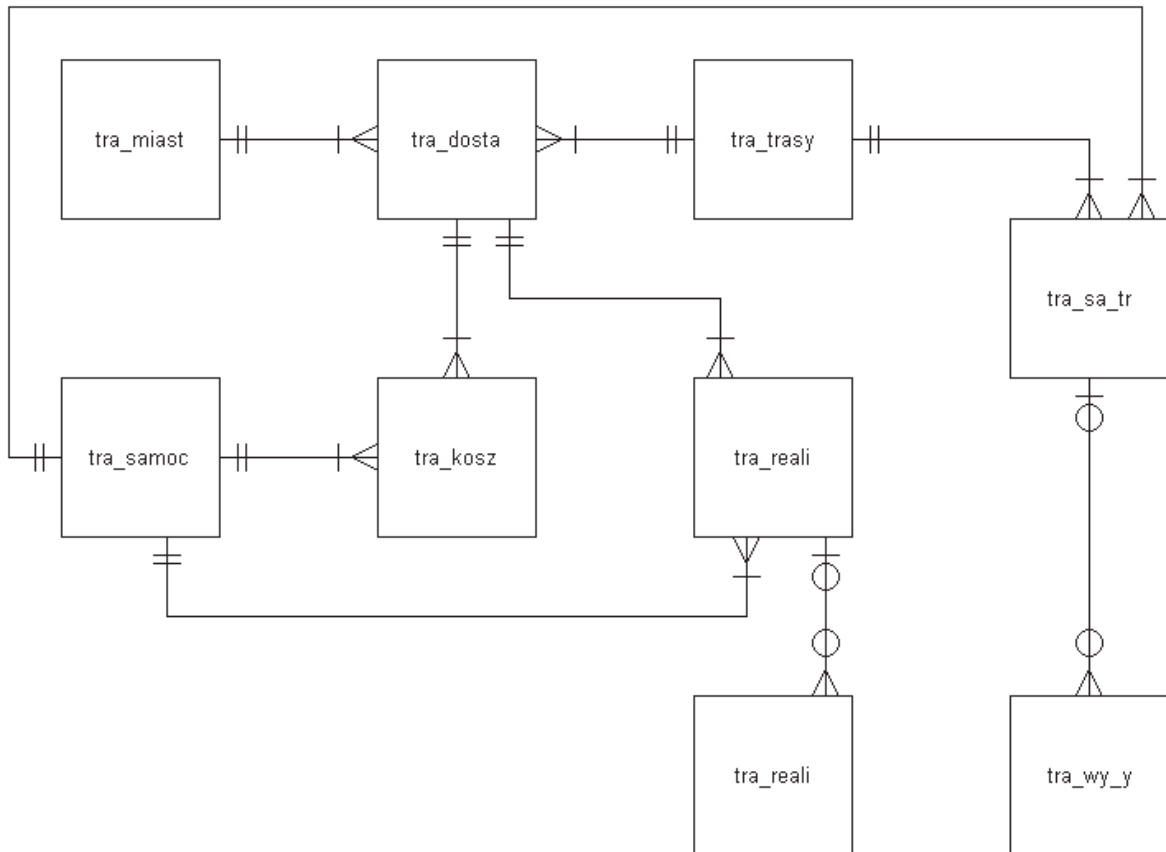

Fig. 4. The part of ERD (simplified Martin’s notation) diagram for questions parameters tables.

Table name <i>description</i>	Symbol	Column name	Key	Column description
tra_miast <i>delivery points</i>	j	kd_idmia	pk	ID delivery point
	naz	id_nazwa		The name of the point
	z	id_zapot		The demand for pallets
tra_trasy <i>Routes</i>	i	kd_idtra	pk	ID route
	naz	id_nazwa		The name of the route
tra_dosta <i>delivery points along the route</i>	j	kd_idmia	pk(fk)	ID delivery point
	i	kd_idtra	pk(fk)	ID route
tra_samoch <i>truck types</i>	l	kd_idsam	pk	ID type of truck
	k	id_poj_k		The capacity of truck type (in pallets)
	u	id_kur_u		Feasible number of courses
	w	id_cza_w		Feasible duration of the courses
tra_sa_tr <i>allocation of trucks to the routes</i>	i	kd_idtra	pk(fk)	ID route
	l	kd_idsam	pk(fk)	ID type of truck
	c	id_kos_c		The cost of route by the truck type

	e	id_cza_e		The time course of truck type on the route
	y	iw_kursy		The number of curses of truck type (solution)
tra_reali <i>number of pallets</i>	j	kd_idmia	pk (fk)	ID delivery point
	i	kd_idtra	pk (fk)	ID route
	l	kd_idsam	pk (fk)	ID type of truck
	X	iw_dosts		The number of pallets (solution)
tra_koszt <i>the cost of delivery</i>	j	kd_idmia	pk(fk)	ID delivery point
	i	kd_idtra	pk(fk)	ID route
	l	kd_idsam	pk(fk)	ID type of truck
	b	id_koszt		the cost of delivery

Table 3. Questions parameters tables (problem of allocation of pallets)-the part of the additional information layer

Practical application of decision support system is shown for the problem of allocation of pallets in regional FMCG distribution center. In this example, asked question (minimize transportation costs) has been implemented as a model of the MIP. The Question parameters tables for the above problem and the relationships between the tables have been presented in Table 3 and Fig 4.

The full MIP model as a CLP predicate, generated based on the discussed information layer in the form of a text file accepted by the ECLIPSE -CLP (Apt et al, 2007) package is shown in Fig.5.

```

:- module(dane).
:- lib(fd).
:- lib(fd_global).
:- lib(edge_finder3).
:- lib(branch_and_bound).
:- local struct(zadanie(start, czas, wymaga, ludzie)).
:- export
dane/12
.
dane(Z, D, K, U, W, C, E, X, Y, Xopr, Yopr, Razem) :-
  Z = [25,10,15,10,20,30,25,15],
  D = [[1,1,1,0,0],[1,1,0,1,0],[1,1,0,1,0],[0,0,1,1,1],[0,0,1,1,1],
        [1,0,1,0,1],[0,1,1,1,0],[1,1,1,0,0]],
  K = [10,6],
  U = [12,12],
  W = [58,58],
  C = [10,8,12,9,16,13,12,9,7,5],
  E = [ [ 5,6,8,6,6 ], [ 5,6,8,6,6 ] ],
  B = [8,6,8,6,8,6,0,0,0,0,6,4,6,4,0,0,6,4,0,0,6,5,6,5,0,0,6,5,0,0,0,0,0,0,
        5,5,6,6,5,5,0,0,0,0,6,4,6,4,6,4,6,5,0,0,6,5,0,0,6,5,0,0,8,6,8,6,8,6,
        0,0,8,6,8,7,8,7,0,0,0,0],
  X= [[Xp111,Xp112],[Xp121,Xp122],[Xp131,Xp132],[Xp141,Xp142],[Xp151,Xp152]],
      [[Xp211,Xp212],[Xp221,Xp222],[Xp231,Xp232],[Xp241,Xp242],[Xp251,Xp252]],
      [[Xp311,Xp312],[Xp321,Xp322],[Xp331,Xp332],[Xp341,Xp342],[Xp351,Xp352]],
      [[Xp411,Xp412],[Xp421,Xp422],[Xp431,Xp432],[Xp441,Xp442],[Xp451,Xp452]],
      [[Xp511,Xp512],[Xp521,Xp522],[Xp531,Xp532],[Xp541,Xp542],[Xp551,Xp552]],
      [[Xp611,Xp612],[Xp621,Xp622],[Xp631,Xp632],[Xp641,Xp642],[Xp651,Xp652]],

```

```

[[Xp711,Xp712],[Xp721,Xp722],[Xp731,Xp732],[Xp741,Xp742],[Xp751,Xp752]],
[[Xp811,Xp812],[Xp821,Xp822],[Xp831,Xp832],[Xp841,Xp842],[Xp851,Xp852]]
],
Xopr=[[Xp111,Xp211,Xp311,Xp411,Xp511,Xp611,Xp711,Xp811],
[Xp121,Xp221,Xp321,Xp421,Xp521,Xp621,Xp721,Xp821],
[Xp131,Xp231,Xp331,Xp431,Xp531,Xp631,Xp731,Xp831],
[Xp141,Xp241,Xp341,Xp441,Xp541,Xp641,Xp741,Xp841],
[Xp151,Xp251,Xp351,Xp451,Xp551,Xp651,Xp751,Xp851]],
[[Xp112,Xp212,Xp312,Xp412,Xp512,Xp612,Xp712,Xp812],
[Xp122,Xp222,Xp322,Xp422,Xp522,Xp622,Xp722,Xp822],
[Xp132,Xp232,Xp332,Xp432,Xp532,Xp632,Xp732,Xp832],
[Xp142,Xp242,Xp342,Xp442,Xp542,Xp642,Xp742,Xp842],
[Xp152,Xp252,Xp352,Xp452,Xp552,Xp652,Xp752,Xp852]]],
(foreach(X1,X),foreach(Z1,Z)do(foreach(X11,X1),param(Z1)do
(foreach(X111,X11),param(Z1)doX111#<=Z1,X111#>=0))),
Y=[[Yp11,Yp12],[Yp21,Yp22],[Yp31,Yp32],[Yp41,Yp42],[Yp51,Yp52]],
Yopr=[[Yp11,Yp21,Yp31,Yp41,Yp51],[Yp12,Yp22,Yp32,Yp42,Yp52]],
(foreach(U1,U),foreach(Y1,Yopr)do(foreach(Y2,Y1),param(U1)do
Y2#>=0,Y2#<=U1)),
flatten(Y,Ypo),flatten(C,Cpo),
(foreach(C1,Cpo),foreach(Y1,Ypo),foreach(Fy1,Fun_y)doFy1#<=C1*Y1),
flatten(X,Xpo),
(foreach(B1,B),foreach(X1,Xpo),foreach(Fx1,Fun_x)doFx1#<=B1*X1),
sumlist(Fun_y,Razem1),sumlist(Fun_x,Razem2),Razem#<=Razem1+Razem2

```

Fig. 5.a. The MIP model (input data) for the problem of allocation of pallets- automatically generated (Eclipse-CLP).

```

:- module(funkcje).
:- use_module(dane).
:- lib(fd).
:- lib(fd_global).
:- lib(fd_search).
:- lib(edge_finder3).
:- lib(branch_and_bound).
:- lib(probing_for_scheduling).
:- local struct(zadanie(start,czas,wymaga,ludzie)).
:- local struct(nazwa(napis)).
:- export
opc/0
.
og_d1(X,D,Z):-
(foreach(X1,X),foreach(D1,D),foreach(Z1,Z)do
(foreach(X2,X1),foreach(D2,D1),param(Z1)do
(foreach(X3,X2),param(D2),param(Z1)doX3#<=D2*Z1))).
og_1(X,Z):-
(foreach(X1,X),foreach(Z1,Z)doflatten(X1,X2),sumlist(X2,Z1)).
og_2(K,U,Xopr):-
(foreach(K1,K),foreach(U1,U),foreach(X1,Xopr)do
flatten(X1,X2),sumlist(X2,X3),X3#<=U1*K1).
og_3(U,Yopr):-
(foreach(U1,U),foreach(Y1,Yopr)dosumlist(Y1,Y2),Y2#<=U1).
ogr_4(Xopr,K,Yopr):-
(foreach(K1,K),foreach(Y1,Yopr),foreach(X1,Xopr)do
(foreach(Y2,Y1),param(K1),foreach(X2,X1)do

```

```

sumlist(X2,X3), X3 #<= K1 * Y2 ) ).
ogr_6(E,Yopr,W):-
(foreach(W1,W), foreach(Y1,Yopr), foreach(E1,E) do
(foreach(E2,E1),foreach(Y2,Y1), foreach(C1,C) do
C1 #= E2 * Y2 ), sumlist(C,C3), C3 #<= W1 ).

s1(L_L1,L_L2):-
flatten(L_L1,L1), flatten(L_L2,L2),
append(L2,L1,L3),
search(L2,0, most_constrained,indomain_split,complete,[]),
search(L1,0, most_constrained,indomain_split,complete,[]).
zapis(X,Y):-
open("w_1.txt",write,Sp_1), flatten(X,X1),
(foreach(X2,X1), param(Sp_1) do write(Sp_1,X2), writeln(Sp_1,' ') ),
writeln(Sp_1,' '), close(Sp_1),
open("w_2.txt",write,Sp_2), flatten(Y,Y1),
(foreach(Y2,Y1), param(Sp_2) do write(Sp_2,Y2), writeln(Sp_2,' ') ),
writeln(Sp_2,' '),
close(Sp_2).
opc:-

dane(Z, D, K, U, W, C, E, X, Y,Xopr,Yopr,Razem),
og_d1(X,D,Z),
og_1(X,Z),
og_2(K,U,Xopr),
og_3(U,Yopr),
ogr_4(Xopr,K,Yopr),
bb_min(s1(Yopr,Xopr),Razem, bb_options with [strategy: step]),
zapis(X,Y).

```

Fig.5.b. The MIP model (constraints) for the problem of allocation of pallets- automatically generated (Eclipse-CLP).

Computational experiments were performed using the data from Table 4a. The calculations are made for three different sets of parameters U, W (examples 1, 2, 3). Results were as follows: Example1 Cost = 1054, Example2 Cost = 1028, Example3 Cost = 1050. The differences are caused by changes in the parameters U and W. The values of decision variables (X, Y) corresponding to the optimal solutions are presented in Table 4b. There is a solution of Example2 from the practice in this table. This is a feasible solution. What is the most interesting when comparing the two solutions of Example2, that address the optimal supply of pallets is possible using a smaller number of courses. This information is important because of the costs and organization of work in other areas such as on the daily demand for trucks, drivers, etc.

tra_miast		tra_dosta								tra_sa_tr				tra_samoc			
j	Z	j	i	j	i	j	i	j	i	i	l	C	E	l	K	U	W
1	25	1	1	3	1	5	3	7	2	1	1	10	5	Example1			
2	10	1	2	3	2	5	4	7	3	1	2	8	5	1	10	10	80
3	15	1	3	3	4	5	5	7	4	2	1	12	6	2	6	10	80
4	10	2	1	4	3	6	1	8	1	2	2	9	6	Examplet2			
5	20	2	2	4	4	6	3	8	2	3	1	16	8	1	10	12	80

6	30	2	4	4	5	6	5	8	3	3	2	13	8	2	6	12	80
7	25									4	1	12	6	Example3			
8	15									4	2	9	6	1	10	12	58
										5	1	7	6	2	6	12	58
										5	2	5	6				

tra_koszt															
j	i	l	B	j	i	l	B	j	i	l	B	j	i	l	B
1	1	1	8	3	1	1	6	5	3	1	6	7	2	1	8
1	1	2	6	3	1	2	5	5	3	2	4	7	2	2	6
1	2	1	8	3	2	1	6	5	4	1	6	7	3	1	8
1	2	2	6	3	2	2	5	5	4	2	4	7	3	2	6
1	3	1	8	3	4	1	6	5	5	1	6	7	4	1	8
1	3	2	6	3	4	2	5	5	5	2	4	7	4	2	6
2	1	1	6	4	3	1	5	6	1	1	6	8	1	1	8
2	1	2	4	4	3	2	5	6	1	2	5	8	1	2	6
2	2	1	6	4	4	1	6	6	3	1	6	8	2	1	8
2	2	2	4	4	4	2	6	6	3	2	5	8	2	2	7
2	4	1	6	4	5	1	5	6	5	1	6	8	3	1	8
2	4	2	5	4	5	2	5	6	5	2	5	8	3	2	7

Table 4.a. Data for computational examples

Example1 fc=1054-optimal				Example2 fc=1026-optimal				Example2 fc=1119-feasible				Example3 fc=1050-optimal			
j	i	l	X	j	i	l	X	j	i	l	X	j	l	l	X
1	1	1	11	1	1	2	25	1	1	2	25	1	1	2	25
1	1	2	14	2	1	2	10	2	1	2	5	2	1	1	2
2	1	2	10	3	1	1	14	2	4	2	5	2	1	2	8
3	1	1	14	3	4	1	1	3	1	1	15	3	1	1	15
3	4	1	1	4	5	1	10	4	3	1	10	4	5	1	10
4	5	1	10	5	5	1	2	5	3	1	2	5	5	1	8
5	4	2	2	5	5	2	18	5	5	2	18	5	5	2	12
5	5	2	18	6	1	1	2	6	1	1	23	6	5	1	30
6	5	1	30	6	5	1	28	6	3	1	7	7	4	1	19
7	4	1	9	7	2	2	6	7	3	1	6	7	4	2	6
7	4	2	16	7	4	1	19	7	4	2	19	8	1	2	15
8	1	1	15	8	1	1	2	8	3	1	15				
	<b>i</b>	<b>l</b>	<b>Y</b>	8	1	2	13		<b>i</b>	<b>l</b>	<b>Y</b>		<b>i</b>	<b>l</b>	<b>Y</b>
	1	1	4		<b>i</b>	<b>l</b>	<b>Y</b>		1	1	4		1	1	2
	1	2	4		1	1	2		1	2	5		1	2	8
	4	1	1		1	2	8		2	1	4		4	1	2
	4	2	3		2	2	1		3	1	4		4	2	1
	5	1	4		4	1	2		4	2	4		5	1	5
	5	2	3		5	1	4		5	2	3		5	2	2
					5	2	3								

Table 4.b. Solutions for computational examples

#### 4.2 Multi-stage transportation problem

The standard is determining the delivery of homogenous materials (commodity) from  $n$  suppliers to  $m$  purchasers. Multi-stage transportation problem, which in addition to suppliers and customers, there are still intermediate points such as distribution centers (Fig.2). Where the set  $W = \{W_1, W_2, \dots, W_n\}$  specifies the suppliers/manufacturers/, the set  $O = \{O_1, O_2, \dots, O_m\}$  purchasers (delivery points) and set  $P = \{P_1, \dots, P_k\}$  intermediaries such as warehouses, distribution centers, logistic warehouses.

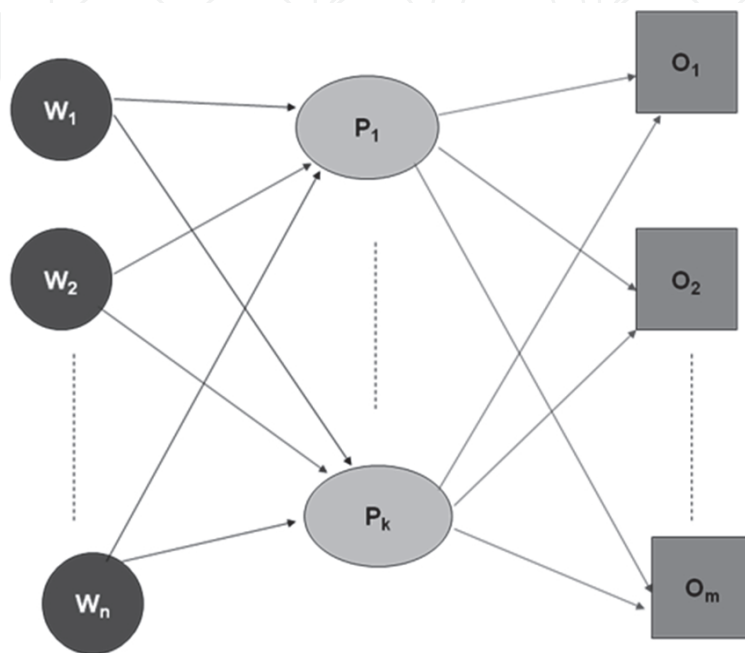

Fig. 6. The network for multi-stage transportation problem

Symbol	Description
<b>Indices</b>	
$j$	delivery point ( $j=1..M$ )
$i$	facility/factory ( $i=1..N$ )
$s$	distribution center ( $s=1..E$ )
$N$	the number of factories
$M$	the number of delivery points
$E$	the number of distribution centers
<b>Input Parameters</b>	
$C_j$	production cost for the factory $i$ ( $i=1..N$ ).
$W_i$	production capacity for factory $i$ ( $i=1..N$ ).
$Z_j$	demand for delivery point $j$ ( $j=1..M$ )
$A_{is}$	the cost of delivery from factory $i$ to distribution center $s$ ( $i=1..N$ ) ( $s=1..E$ )
$G_{sj}$	the cost of delivery from distribution center $s$ to delivery point $j$ ( $s=1..E$ ) ( $j=1..M$ )
<b>Decision Variables</b>	
$X_{is}$	the part of the delivery from factory $i$ to distribution center $s$
$Y_{sj}$	the part of delivery from distribution center $s$ to delivery point $j$

Table 5. The indices, input parameters and the decision variables for optimization model.

A mathematical model of optimization for multi-stage transportation problem has been formulated as a linear programming problem of minimizing the objective function which represents the total cost of transport and production under constraints (1) to (5). Constraint (1) ensures that every requirement is met, that is, that each distribution center receives delivery from the factory due to the production capacity. The fulfillment of the delivery for delivery point enforces constraint (2). Balancing the distribution centers, i.e. the supply and shipping ensures constraint (3). Constraints (4), (5) are the standard constraints for the problem of integer linear programming.

**Objective Function** - minimize transportation and production costs:

$$\sum_{i=1}^N \sum_{s=1}^E A_{i,s} * X_{i,s} + \sum_{s=1}^E \sum_{j=1}^M G_{s,j} * Y_{s,j} + \sum_{i=1}^N (C_i * \sum_{s=1}^E X_{i,s})$$

**Subject to:**

$$\sum_{s=1}^E X_{i,s} \leq W_i \text{ for } i = 1..N \tag{1}$$

$$\sum_{s=1}^E Y_{s,j} \geq Z_j \text{ for } j = 1..M \tag{2}$$

$$\sum_{i=1}^N X_{i,s} = \sum_{j=1}^M Y_{s,j} \text{ for } s = 1..E \tag{3}$$

$$X_{i,s} \geq 0 \text{ for } i = 1..N, s = 1..E, \text{ integer} \tag{4}$$

$$Y_{s,j} \geq 0 \text{ for } s = 1..E, j = 1..M, \text{ integer} \tag{5}$$

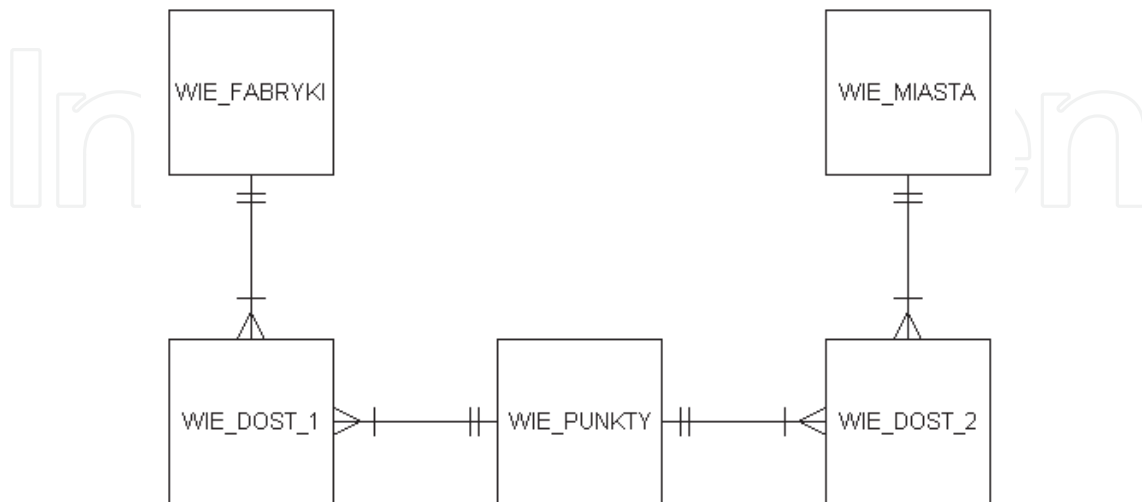

Fig. 7. The part of ERD (simplified Martin’s notation) diagram for questions parameters tables



In this example, asked question (minimize transportation and production costs) has been implemented also as a model of the MIP. The question parameters tables for the above problem and the relationships between these tables have been presented in Table 6a, Table 6b and Fig. 7.

The full MIP model as a CLP predicate, generated based on the discussed information layer in the form of a text file accepted by the ECLIPSE – CLP package is shown in Fig.8a and Fig.8b.

```

:- module(dane_1_p).
:- lib(fd).
:- lib(fd_global).
:- lib(edge_finder3).
:- lib(branch_and_bound).
:- export
dane/8
.
dane(Z,C,W,X,Xt,Yt,Y,Razem):-
  Z = [4, 3, 2, 2, 3, 4],
  C = [180, 200, 190 ],
  W = [12, 10, 10],
  A = [30, 20, 90, 40, 80, 60],
  G = [30, 20, 40, 70, 50, 60, 90, 40, 50, 30, 40, 40],
  X = [ [X11, X12], [X21, X22], [X31, X32] ],
  Xt = [ [X11, X21, X31], [X12, X22, X32] ],
  Y = [ [Y11, Y12, Y13, Y14, Y15, Y16], [Y21, Y22, Y23, Y24, Y25, Y26] ],
  Yt = [[Y11,Y21],[Y12,Y22],[Y13,Y23],[Y14,Y24],[Y15, Y25],[Y16,Y26] ],
  flatten(Y,Ypo),
  flatten(X,Xpo),
  (foreach(X1,X),
   foreach(W1,W) do
    (foreach(X11,X1), param(W1) do
     X11 #>= 0,
     X11 #<= W1 ) ),
  (foreach(Y1,Yt),
   foreach(Z1,Z) do
    (foreach(Y11,Y1), param(Z1) do
     Y11 #>= 0,
     Y11 #<= Z1 ) ),
  (foreach(X1,Xpo),
   foreach(A1,A),
   foreach(Sx1,Sum_x) do
    Sx1 #=X1 * A1 ),
  sumlist(Sum_x,Razem1),
  (foreach(Y1,Ypo),
   foreach(G1,G),
   foreach(Sy1,Sum_y) do
    Sy1 #=Y1 * G1 ),
  sumlist(Sum_y,Razem2),
  (foreach(Xk1,X),
   foreach(C1,C),
   foreach(Sk1,Sum_k) do
    sumlist(Xk1,Raz_s),
    Sk1 #=Raz_s * C1 ),
  sumlist(Sum_k,Razem3),
  Razem #= Razem1+Razem2+Razem3
.

```

Fig. 8.a. The MIP model (input data) for the multi-stage transportation problem-automatically generated (Eclipse-CLP).

```

:- module(funkcje_1_p).
:- use_module(dane_1_p).
:- lib(fd).
:- lib(fd_global).
:- lib(fd_search).
:- lib(edge_finder3).
:- lib(branch_and_bound).
:- lib(probing_for_scheduling).
:- local_struct(zadanie(start,czas,wymaga,ludzie)).
:- local_struct(nazwa(napis)).
:- export
opc/0
.
og_1(X,W):-
  (foreach(X1,X),
   foreach(W1,W) do
    sumlist(X1,X_sum), X_sum #<= W1 ).
og_2(Yt,Z):-
  (foreach(Y1,Yt),
   foreach(Z1,Z) do
    sumlist(Y1,Z1) ).
og_3(Y,Xt):-
  (foreach(Y1,Y),
   foreach(X1,Xt) do
    sumlist(Y1,Y_sum),
    sumlist(X1,X_sum), Y_sum #= X_sum ).
s1(L_L1,L_L2):-
  flatten(L_L1,L1),
  flatten(L_L2,L2),
  append(L2,L1,L3),
  search(L3,0, most_constrained,indomain_min,complete, []).
zapis(X,Y):-
  open("w_1.txt",write,Sp_1),
  flatten(X,X1),
  (foreach(X2,X1), param(Sp_1) do
   write(Sp_1,X2),
   writeln(Sp_1,' ') ),
  writeln(Sp_1,' '),
  close(Sp_1),
  open("w_2.txt",write,Sp_2),
  flatten(Y,Y1),
  (foreach(Y2,Y1), param(Sp_2) do
   write(Sp_2,Y2),
  writeln(Sp_2,' ') ),
  writeln(Sp_2,' '),
  close(Sp_2).
opc:-
  dane(Z,C,W,X,Xt,Yt,Y,Razem),
  og_1(X,W),
  og_2(Yt,Z),
  og_3(Y,Xt),
  bb_min(s1(X,Yt),Razem, bb_options with [strategy: step]),
  zapis(X,Yt).

```

Fig. 8.b. The MIP model (constraints) for the multi-stage transportation problem-automatically generated (Eclipse-CLP)

Example P1-parameter A

(i) \ (s)	1	2	C <sub>i</sub>	W <sub>i</sub>
1	30	20	180	600
2	90	40	200	500
3	80	60	190	500

Example P1-parameter G

(s) \ (j)	1	2	3	4	5	6
1	30	20	40	70	50	60
2	90	40	50	30	40	40
Z <sub>j</sub>	200	150	100	100	150	200

Example P2- parametr A

(s) \ (i)	1	2	3	4	5	C <sub>i</sub>	W <sub>i</sub>
1	30	40	30	40	30	180	60 0
2	90	40	40	50	40	200	50 0
3	80	60	70	70	50	190	50 0
4	30	20	30	40	30	150	30 0

Example P2-parametr G

(s) \ (j)	1	2	3	4	5	6
1	30	20	40	70	50	60
2	90	40	50	30	40	40
3	20	50	60	60	90	60
4	30	30	50	70	60	60
5	90	40	50	30	40	40
Z <sub>j</sub>	300	250	300	220	150	200

Table 6.a. Data for computational examples

Example 1 fc = 26500						Example2 fc = 345400					
i	s	X	s	j	Y	i	s	X	s	j	Y
1	1	350	1	1	200	1	1	550	1	2	250
1	2	250	1	2	150	1	3	50	1	3	300
2	2	300	2	3	100	2	3	250	2	4	100
			2	4	100	2	5	250	2	6	200
			2	5	150	3	5	20	3	1	300
			2	6	200	4	2	300	5	4	120
									5	5	150

Table 6.b. Solutions for computational examples

Computational experiments were performed using the data from Table 6a. The calculations are made for two examples (different number of distribution centers, factories). Results were as follows: Example1 Cost = 26500, Example2 Cost = 345400. The

results obtained make it possible to find answers to additional questions: Which distribution centers are the most used? Which plants are the largest suppliers? Are there unnecessary distribution centers?

## 5. Conclusions

The paper presents a general concept for the decision support system for the outbound logistic in supply chain. The unique contribution of the presented concept in the form of an additional layer of information is flexibility. It can be used to implement any questions as developed constraint logic programming. It proposes a very flexible and versatile means of automatic generation of decision-making models based on the contents of the database.

It should be noted that the quality of the proposed decision-making models, which correspond to the respective entries to the system tables depends on the quality of generated decision. It is worth noting that the entries in the system tables for the type of decision-making model are executed only once. Ready-made questions (decision making models) are longer automatically generated even if you change the data in the database ERP system.

## 6. References

- Apt K.R, Wallace M.G. (2007). *Constraint Logic Programming Using ECLiPSe*, ISBN-13978-0-521-88628-6, Cambridge.
- Chapters in a print book
- Cornelis, Roos. Terlaky Tamás. Vial Jean-Philippe. (2006). *Interior Point Methods for Linear Optimization*. Second Edition, ISBN 0387263780, Springer-Verlag.
- Douglas, M. Lambert, Martha. Cooper C. (2000) *Issues in Supply Chain Management in Industrial Marketing Management*, ISSN 0019-8501, Volume 29, Issue 1, pp 65-83.
- Frühwirth, Thom., Slim, Abdennadher., (2003). *Essentials of constraint programming*, ISBN 978-3-540-67623-2, Springer.
- Geoffrion, A.M. Graves G.W. (1974). *Multicommodity distribution system design by Bender's decomposition in Management Science* 20 (5), ISSN 0025-1909, pp. 822-844.
- Moon Y.B. (2007). *Enterprise Resource Planning (ERP): a review of the literature*, in *J.Management and Enterprise Development*, ISSN 1468-4330, Vol. 4, No. 3, pp. 235-264.
- Pesic, M. (2008) *Constraint-Based Workflow Management Systems: Shifting Control to Users*. PhD thesis, ISBN 978-90-386-1319-2, Eindhoven University of Technology.
- Schrijver, A. (1998). *Theory of Linear and Integer Programming*. ISBN 0-471-98232-6, John Wiley & sons.
- Shapiro, J.F. (2001). *Modeling the Supply Chain*, ISBN 978-0-534-37741 Duxbury Press.
- Simchi-Levi, D., Kaminsky, P., Simchi-Levi E. (2003). *Designing and Managing the Supply Chain: Concepts, Strategies, and Case Studies*. McGraw-Hill, ISBN 978-0-07-119896-7, New York.

Vanderbei, R. J. (2008). *Linear Programming: Foundations and Extensions*. 3rd ed., International Series in Operations Research & Management Science, Vol. 114, ISBN 978-0-387-74387-5, Springer Verlag.

IntechOpen

IntechOpen

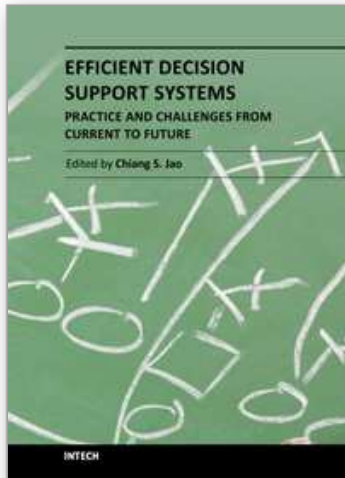

## **Efficient Decision Support Systems - Practice and Challenges From Current to Future**

Edited by Prof. Chiang Jao

ISBN 978-953-307-326-2

Hard cover, 542 pages

**Publisher** InTech

**Published online** 09, September, 2011

**Published in print edition** September, 2011

This series is directed to diverse managerial professionals who are leading the transformation of individual domains by using expert information and domain knowledge to drive decision support systems (DSSs). The series offers a broad range of subjects addressed in specific areas such as health care, business management, banking, agriculture, environmental improvement, natural resource and spatial management, aviation administration, and hybrid applications of information technology aimed to interdisciplinary issues. This book series is composed of three volumes: Volume 1 consists of general concepts and methodology of DSSs; Volume 2 consists of applications of DSSs in the biomedical domain; Volume 3 consists of hybrid applications of DSSs in multidisciplinary domains. The book is shaped upon decision support strategies in the new infrastructure that assists the readers in full use of the creative technology to manipulate input data and to transform information into useful decisions for decision makers.

### **How to reference**

In order to correctly reference this scholarly work, feel free to copy and paste the following:

Paweł Sitek and Jarosław Wikarek (2011). The Declarative Framework Approach to Decision Support for Constrained Search Problems, *Efficient Decision Support Systems - Practice and Challenges From Current to Future*, Prof. Chiang Jao (Ed.), ISBN: 978-953-307-326-2, InTech, Available from: <http://www.intechopen.com/books/efficient-decision-support-systems-practice-and-challenges-from-current-to-future/the-declarative-framework-approach-to-decision-support-for-constrained-search-problems>

**INTECH**  
open science | open minds

### **InTech Europe**

University Campus STeP Ri  
Slavka Krautzeka 83/A  
51000 Rijeka, Croatia  
Phone: +385 (51) 770 447  
Fax: +385 (51) 686 166  
[www.intechopen.com](http://www.intechopen.com)

### **InTech China**

Unit 405, Office Block, Hotel Equatorial Shanghai  
No.65, Yan An Road (West), Shanghai, 200040, China  
中国上海市延安西路65号上海国际贵都大饭店办公楼405单元  
Phone: +86-21-62489820  
Fax: +86-21-62489821

© 2011 The Author(s). Licensee IntechOpen. This chapter is distributed under the terms of the [Creative Commons Attribution-NonCommercial-ShareAlike-3.0 License](#), which permits use, distribution and reproduction for non-commercial purposes, provided the original is properly cited and derivative works building on this content are distributed under the same license.

IntechOpen

IntechOpen