

We are IntechOpen, the world's leading publisher of Open Access books Built by scientists, for scientists

4,800

Open access books available

122,000

International authors and editors

135M

Downloads

Our authors are among the

154

Countries delivered to

TOP 1%

most cited scientists

12.2%

Contributors from top 500 universities



WEB OF SCIENCE™

Selection of our books indexed in the Book Citation Index
in Web of Science™ Core Collection (BKCI)

Interested in publishing with us?
Contact book.department@intechopen.com

Numbers displayed above are based on latest data collected.
For more information visit www.intechopen.com



Estimation of Carbon Coatings Manufactured on Magnesium Alloys

IntechOpen

Marcin Golabczak

*Technical University of Lodz,
Department of Production Engineering
Poland*

1. Introduction

Magnesium (Mg) is one of the most abundant structural metals on the earth. Magnesium resources are estimated on approximately 1,93% of mass of the earth's crust and 0,13% of mass of the oceans. Magnesium is present in salt water in form of chlorides (in amount of approximately 1,2 kg/ m³), however in earth crust in form of dolomites composed mainly from carbonates. Magnesium belongs to ultra light metals (1,75 g/ cm³), has silver glossy colour, is soft and ductile, easily reacts chemically with other substances (e.g.: oxygen, nitrogen, carbon dioxide or water). Unfortunately, magnesium has a lot of undesirable properties such as poor corrosion and wear resistance, what limits its use in many usages especially for outdoor applications. For this reason pure magnesium is rarely used in technique, however with other metals (e.g.: aluminum, zinc, manganese, cerium, zirconium and rare earth metals) forms alloys, which are very attractive constructional material. Because of this magnesium alloys found a plethora of applications in various branches of industry where reduction in weight is of importance (Gray & Luan, 2002). These alloys are used in aerospace, automobile (Kawalla et al., 2008) and electronic industries, for manufacturing of sporting goods, high-speed boats, submarines, household equipment, etc. (Fig. 1). The main advantages of magnesium alloys are: the high strength, weight ratio, high thermal conductivity, small heat extensibility, good welding characteristics and high functional integrity, which allow to produce near-net-shape elements as well as good machinability (Hawkins, 1993). However, magnesium alloys have also certain disadvantages. The most troublesome of them is the high susceptibility to corrosion (especially galvanic corrosion), which contributes to dwindling of their size and reduces mechanical durability. As to protect magnesium alloys from corrosion, at present various methods for the fabrication of protective films have been used (Ishizaki et al., 2009). Other disadvantages of magnesium alloys comprise their weak wear resistance, a drop in durability at high temperature and interference of electromagnetic field. The aforementioned faults considerably reduce the area of application of this material. Presented studies aimed at elimination of the listed drawbacks by means of covering of magnesium alloy with special carbon coatings. Plasma Activated Chemical Vapor Deposition (PACVD) method has been used for this purpose. Optimum conditions of this process have been determined and the material properties of the carbon coatings characterized.

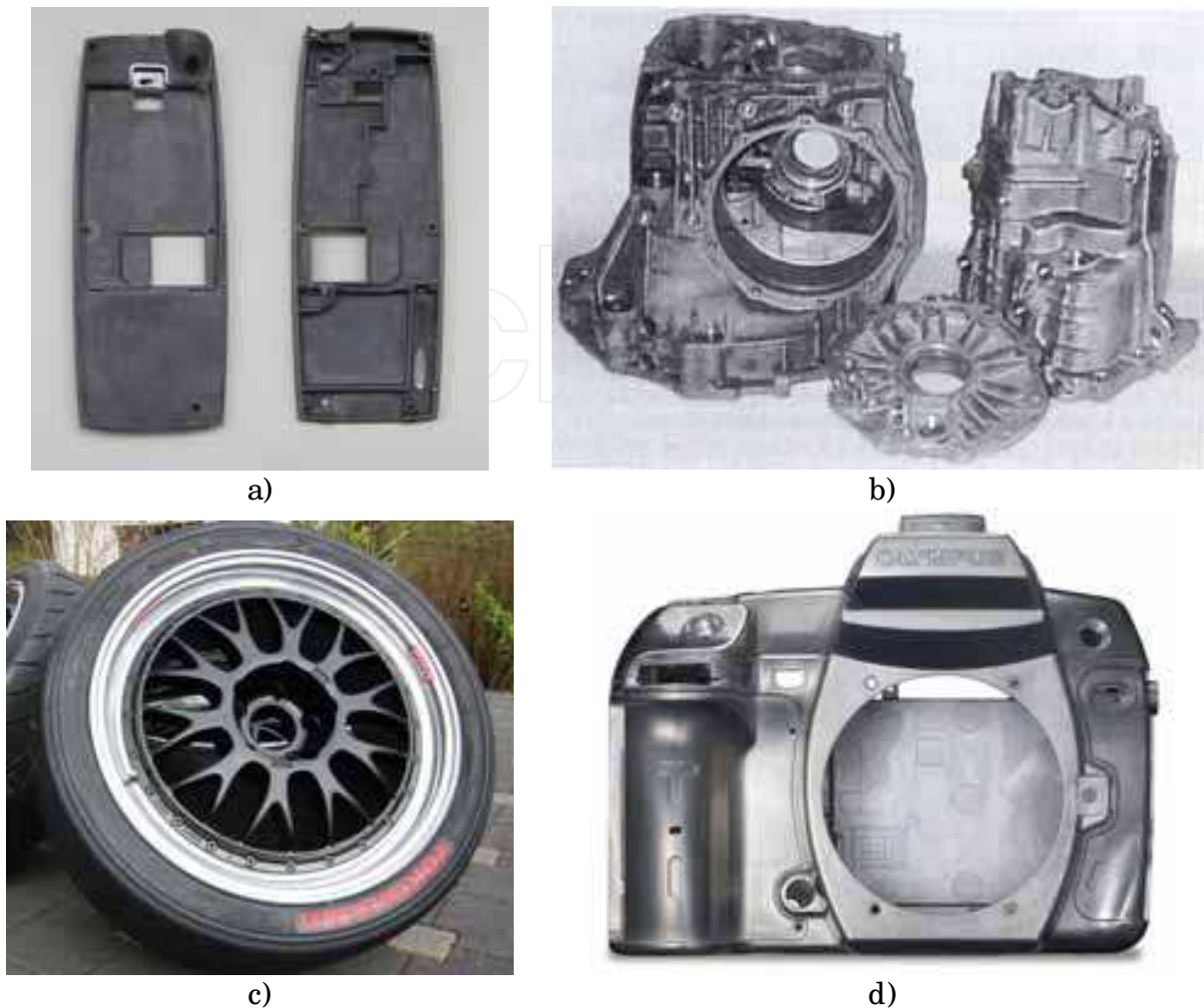

Fig. 1. Examples of use magnesium alloys: a) mobile phone housing, b) wheelcase, cover and flange of differential gear, c) magnesium alloy wheels, or “mag wheels” used on racing cars, d) body front of camera

2. Methods of manufacturing of protective coatings on magnesium alloys

In literature there are many different methods and techniques of manufacturing of protective and decorative coatings on magnesium alloys (Gray & Luan, 2002). Taking into consideration physical processes used in these techniques we can classify seven main methods of manufacturing of protective and decorative coatings on magnesium alloys, which have been presented in figure 2. These include electrochemical plating, conversion coatings, hydride coatings, anodizing, vapour-phase processes, laser cladding and polymer coatings (Golabczak, 2005). All these methods are characterized by different complexity of used technological processes, costs of realization these processes, degree of environmental nuisance and surroundings, as well as functional properties of manufactured coatings and range of their applications. As yet it has not been developed effective method assuring complete corrosion resistance of magnesium alloys and decorative virtues of manufactured coatings. Because of the increasing interest in magnesium alloys in different fields of industry, it is justified to carry out research on elaboration of a “new” methods fulfilling all these requirements in superlative degree.

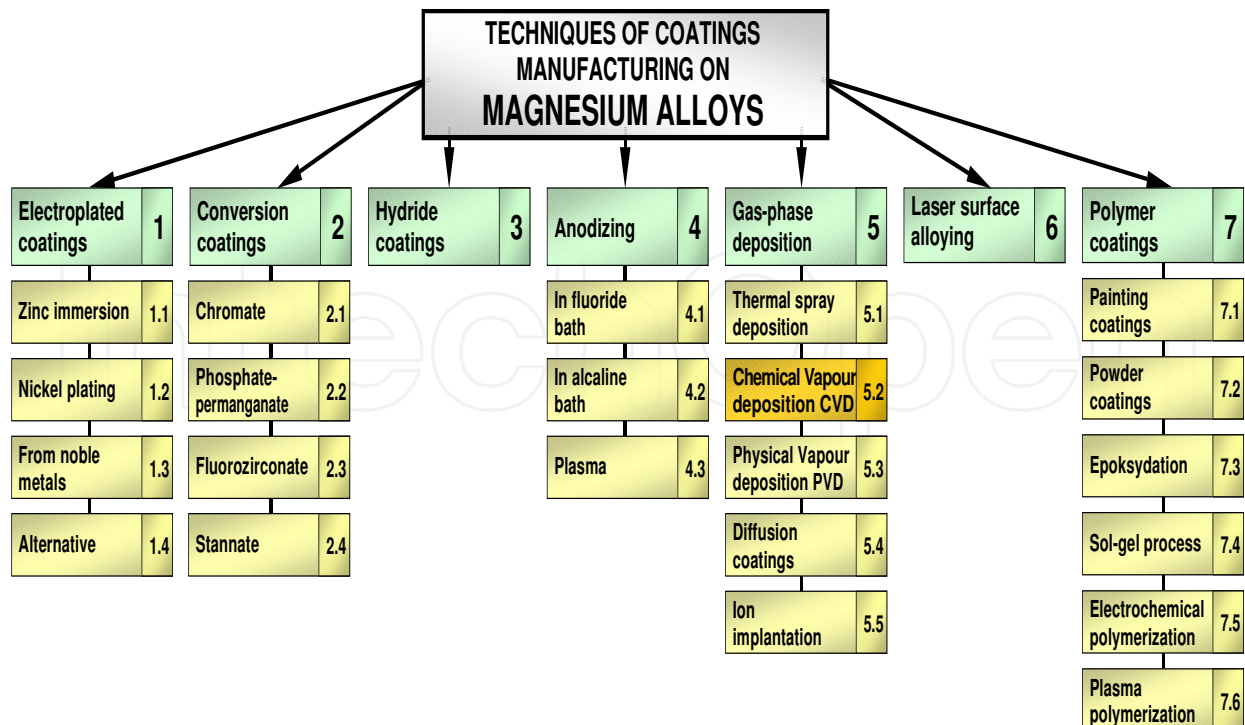

Fig. 2. Techniques of coatings manufacturing on magnesium alloys

3. Characteristic of carbon coatings

Carbon coatings have been characterized by very attractive functional properties, especially by decorative and protective, which predestine them for application in many fields. At present, there are many methods and techniques which are used for their manufacturing, among them dominate techniques exploitative plasma, ion beams and methods of unconventional synthesis (Robertson, 2002). Diversity of these methods and wide range of applied parameters have essential influence on quality of manufactured carbon coatings. Taking into account the structure of manufactured carbon coatings we can identify four basic groups:

- **diamond** – inclusive diamond films - DF and polycrystalline diamond coatings – PCD, which are composed of atoms of configuration σsp^3 , nanocrystalline diamond coatings – NCD, tetrahedral carbon ta-C and amorphous diamond a-D coatings;
- **graphite** – amorphous carbon coatings of graphite structure e.g. *pyrolytic graphite coatings* which are obtained in vacuum pyrolysis process;
- **carbyne** - inclusive α -carbyne contains, which contains acetylic bonds ($-C\equiv C-$) and are also called as *polyacetylene carbyne contains*, β -carbyne coatings, which contains cumulative double bond ($=C=C=$) also called as *polycumulene carbyne coatings*;
- **diamond like carbon** - inclusive *diamond like carbon coatings* – DLC – which are mixture of amorphous or nanocrystalline of carbon containing fraction of σsp^3 bonds - typical for diamond structure, fraction of σsp^2 bonds – typical for graphite and σsp^1 .

Above mentioned structures of carbon coatings have found application for deposition of many constructional materials used for example in: medicine for manufacturing of implants (Niedzielski et al., 1997), tool industry for increasing of durability and wear resistance of cutting edges (Olszyna & Smolik, 2004), jewellery industry for manufacturing of decorative

coatings (Clapa et al., 2001), for coating of polymers used in aerospace industry (Hawkins, 1993), etc. This wide field of application of carbon coatings justifies usefulness their exploitation for covering of magnesium alloys. Among many analyzed methods of manufacturing of carbon coatings especially attractive seems to be PACVD (Plasma Activated Chemical Vapour Deposition) method, elaborated in Technical University of Lodz – Poland. This method is particularly useful for manufacturing carbon coatings mentioned above with predominated part of diamond in these coatings (Niedzielski et al., 1997).

4. The stand for manufacturing of carbon coatings by PACVD method

For investigations AZ31 magnesium alloy samples have been used. AZ31 (ASTM designation) is very commercial alloy used in die casting and plastic forming. The chemical composition (in wt%) of AZ31 is: 2.83 %Al, 0.8% Zn, 0.37% Mn and 0.002% Cu (Kuc et al., 2008). Carbon coatings have been deposited on this alloy by PACVD method, which has relied on decomposition of methane in electric field with high frequency of 13.56 MHz, obtained at the pressure of approximately 12 Pa in a working chamber (Golabczak, 2005). Processes of PACVD have been realized in the stand presented in figure 3. It has consisted of the chamber of water cooled plasma reactor, the high frequency electrode fixed to the plate of the base and connected through the condenser (the latter provided the negative potential of self-polarization), generator of high frequency (facilitated production of plasma with high density and maintained the frequency at the constant level), vacuum system and systems of measurement and control. Carbon coatings have been deposited on AZ31 magnesium alloy in two steps comprising the process of ionic digestion of their surface followed by the process of synthesis of these coatings. Parameters of these steps are shown in table 1.



Fig. 3. The view of the system used for deposition of carbon coatings by PACVD method

Parameter	Ionic digestion of the surface	Process of coating deposition
Feed gas	CH ₄	CH ₄
Pressure in a working chamber	8 ÷ 10 Pa	12 Pa
Time of process - t	4 min	5 ÷ 9 min
Gas flow rate - V	5 cm ³ / min	20÷60 cm ³ / min

Table 1. Optimum parameters of PACVD process

5. Preparation of samples made of magnesium alloys for investigations

Polishing process of samples made of AZ31 magnesium alloy has been carried out using Phoenix Beta 2 (Buehler-Germany) dual platen grinder-polisher machine equipped with Vector power head (Fig. 4) and specimens holder for single force for 3-6 specimens up to max \varnothing 25 mm, according to holder selected. Thus 3 to 6 specimens can be prepared under reproducible conditions. The Buehler grinder-polisher machine has had stepless rotation speed (from 30 to 600 rpm) and the power head settings of control time, pressure (up to 200 N), speed and direction and automatic start and stop system. Vector power head upgrades the Beta 2 grinder-polisher machine to from manual operation to semi-automatic operation, increasing productivity and specimen consistency. This stand is on equipment of Department of Production Engineering of Technical University of Lodz - Poland laboratory.



Fig. 4. The overall view of the Beta 2 dual platen grinder-polisher machine equipped with Vector power head and specimens holder

The samples made of AZ31 hp magnesium alloy of diameter \varnothing 20 mm from TECHNO-COAT Oberflächentechnik GmbH, Zittau-Germany have been used for investigations. The main technological requirement of technological process was to prepare samples of a low surface roughness and removal impurities from their surface layer. For this purpose the technological process of abrasive machining including following grinding and polishing operations, using Buehler equipment and accessories has been elaborated:

- two stage grinding of samples on grinder equipped with self adhesive BuehlerMet silicon carbide abrasive paper; in sequential stages of grinding the granularity of SiC material has been diversified using accordingly: in first stage silicon carbide grits size 26 μm and in second stage silicon carbide grits size 15 μm ; the grinding process has been carried out using wax;
- lapping of samples using medium hard woven silk cloth VerduTex and Buehler MetaDi diamond suspension of diamond grains size 3 μm ; MetaDi is a oil-base product, particularly suitable for soft and water-sensitive materials, absolutely water free with tight distribution of synthetic, monocrystalline diamonds which have a great number of cutting faces. This offers a particularly high material removal rate and scratch-free surfaces of samples;
- final polishing of samples using self-adhesive soft synthetic pad ChemoMet and aluminium oxide (Al_2O_3) final polishing suspension MasterPrep (grains size \varnothing 0,05 μm);
- washing of samples in ethyl alcohol of high purity (99,9 %) Chem Land using ultrasonic washer Polsonic – Sonic 1.

The technological conditions of realized operations of grinding and polishing of AZ31 magnesium alloy samples have been shown in table 2.

Process stages	Abrasive surface	Type of abrasive material	Lubricant type	Process time [min]	Feed force [N/ cm^2]	Rotation speed of platen V [m/ s]
Grinding of sample surface	BuehlerMet silicon carbide abrasive paper	Silicon carbide SiC P 600 (grits size \varnothing 26 μm)	Wax	5	10	6
	BuehlerMet silicon carbide abrasive paper	Silicon carbide SiC P 1200 (grits size \varnothing 15 μm)	Wax	1	5	3
Lapping	Medium hard woven silkcloth VerduTex	Monocrystalline diamond suspension MetaDi -oil based (grains size \varnothing 3 μm)	Oil-based polishing extander Buehler AutoMet Lapping Oil	5	2,5	2
Polishing	Soft synthetic pad ChemoMet	Aluminium oxide (Al_2O_3) final polishing suspension MasterPrep (grains size \varnothing 0,05 μm)	–	3	2,5	1

Table 2. Conditions of technological process of magnesium alloy samples preparation

Elaborated technological process has ensured suitable preparation of samples, in range of required roughness parameters and their proper purity (including removal of machining products). The surface of polished samples has had silver, glossy colour and no visible tool marks.

6. Experimental investigations

Experimental investigations have included determination of technological parameters of the process of manufacturing of carbon coatings on AZ31 magnesium alloy using PACVD method and test of operational properties of coatings manufactured in this process. For arrangement of technological parameters of PACVD process the investigation object model has been accepted, on which affects variable input quantities (controllable), constant quantities and factors of jamming. Modelling setting-up of investigation conditions, inclusive of: variable and constant input quantities, factors of jamming of PACVD process and output quantities have been presented in figure 5.

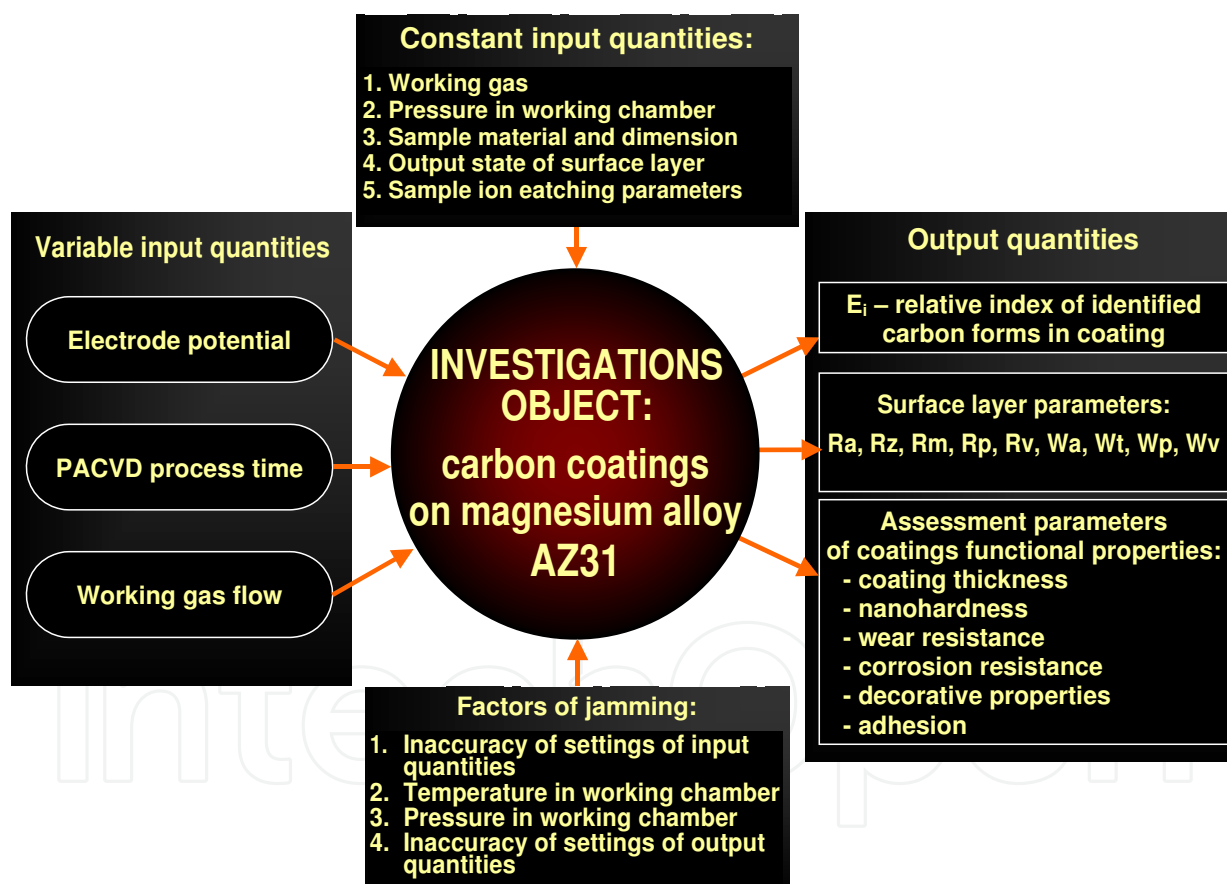

Fig. 5. Modelling setting-up of investigation conditions

Input quantities and areas and their range of variables have been determined basing on technological possibilities of test stand for manufacturing of carbon coatings using PACVD method and preliminary investigation results (Golabczak, 2005). Results of preliminary tests have shown, that polarization potential values of high frequency electrode should not exceed voltage of 1000 V and time of PACVD process 12 minutes. Overdraft of these values has caused excessive heating of samples made of magnesium alloy and their burning. As

output quantities the set of parameters useful both for identification of manufactured carbon coatings on magnesium alloy samples in PACVD process and assessment of their functional properties (Fig. 5). Determined investigation conditions, range of variables and test step have been shown in table 3.

Range of variables and input quantities of PACVD process			
Input quantities Range of variables and test step	Polarization potential U [V]	Time of PACVD process t [min]	Working gas flow V [cm ³ / min]
Ground level	800	7	40
Test step	100	2	20
Upper level	900	9	60
Lower level	700	5	20
Constant input quantities			
No.	Name of quantity	Value/ determination	
1	Working gas -methane	CH ₄	
2	Pressure in working chamber	12 Pa	
3	Samples dimension	Ø 20x2 mm	
4	Preparation of sample surface layer	According to procedure depicted in point No. 5	

Table 3. Investigation conditions and range of variables of input quantities of manufacturing process of carbon coatings using PACVD method

Taking into consideration limitation of costly and labour-intensive experiment designs, the planned fractional experiment 2^{n-1} type has been accepted, in which number of experiments has been equal to 4 (Golabczak, 2005). Design matrix for this type of experiment has been presented in table 4.

No. of sample	Variable input quantities		
	X ₁ Polarization potential of electrode U [V]	X ₂ Time of PACVD process t [min]	X ₃ Working gas flow V [cm ³ /min]
1	+	-	-
2	-	+	-
3	+	-	+
4	-	+	+
+ upper level of input variable (according to data in table 3)			
- ground level of input variable (according to data in table 3)			

Table 4. Plan of fractional experiment 2^{n-1} type of manufacturing of carbon coatings

7. Experimental results

Experiments have included optimization of technological parameters of PACVD process of deposition of carbon films and characterization of their material properties. To determine the optimum conditions of PACVD process, series of tests have been realized according to the fractional experiment 2^{n-1} type (Golabczak, 2005). The studies of material properties of carbon coatings deposited on AZ31 magnesium alloy have comprised identification of these coatings, measurement of their nanohardness and thickness and determination of their geometrical microstructure of surface. Also tribologic measurements of hard carbon coatings, determination of their corrosion resistance and adhesion have been realized.

7.1 Identification of carbon coatings deposited on AZ 31 magnesium alloy

Identification of hard carbon coatings deposited on the surface of AZ31 magnesium alloy has been determined on the basis of their Raman spectra (Golabczak, 2005). For this purpose, the mathematical modeling of fitting of Gaussian peaks of the identified carbon phases to the Raman spectra has been performed (Golabczak, 2005). Exemplary results of Raman spectrum evaluation with using Gaussian profile have been shown in figure 6.

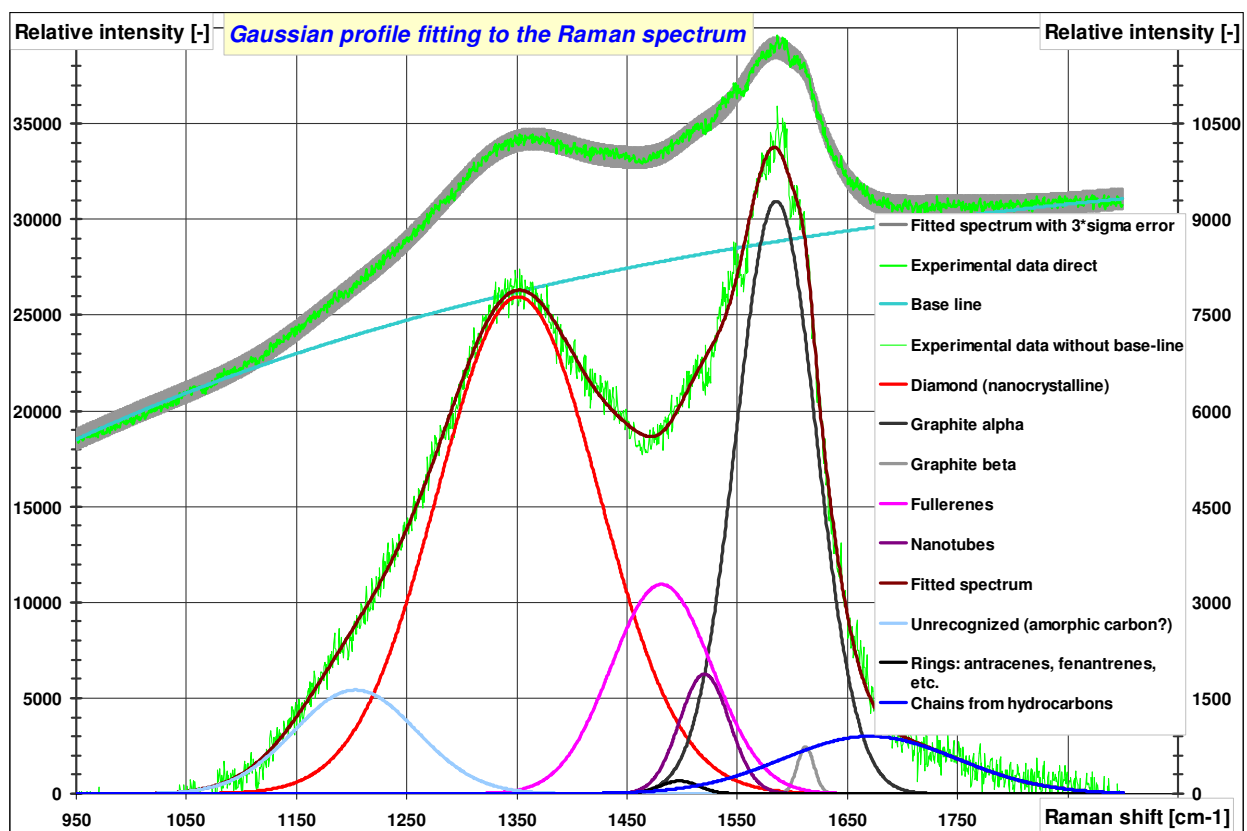

Fig. 6. Results of Raman spectrum evaluation with using Gaussian profile

The contents of the identified carbon phases in the deposited carbon coatings have been determined on the basis of the relative index - E_i , described by the following equation (1):

$$E_i = \frac{A_{p_i}}{A_s} = \frac{\int p_i(x) dx}{\sum \int p_i(x) dx} \quad (1)$$

where: A_{pi} - surface area between the baseline and the curve of fitting to the plot for the carbon phases identified in the coating, calculated by the method of numerical integration; A_s - the summary surface area between the baseline and the curve of fitting to Raman spectrum, calculated by the method of numerical integration (Golabczak, 2007). The quality of identified carbon forms, found in coatings deposited through the successive experimental trials has been determined on the basis of the accepted mathematical model used for fitting the Gaussian peaks spectra to Raman spectra. For this purpose, the relative index E_i has been calculated (according to equation 1). The relative index E_i determines the content of individual carbon forms in the deposited coatings. The graphical interpretation of this method has been shown in figure 7, which presents the relative content of diamond in the deposited carbon coating, attained under optimum PACVD process conditions.

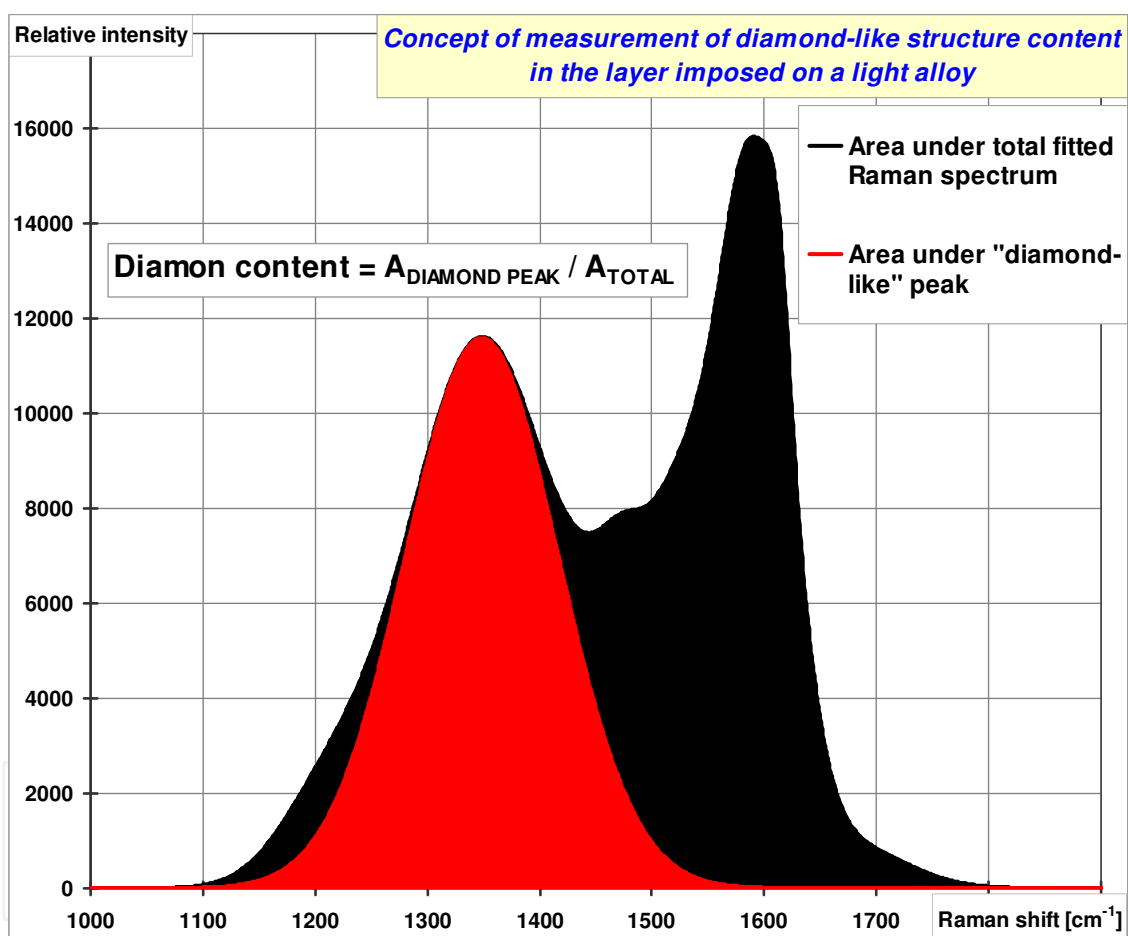

Fig. 7. The concept of measurement of the “diamond-like” structure content in the carbon coating on a light alloy

Results of computing of the relative index E_i , obtained for each specimen prepared within the scope of the planned experiment, have been shown in figure 8.

Analysis of results obtained for individual specimens produced within the scope of the planned experiment (specimens 1÷4), revealed that the diamond phase ($E_i=0.40\div0.48$) and alfa-graphite phase ($E_i=0.20\div0.35$) have dominated in the deposited coatings. Also other carbon phases have been identified, such as beta-graphite- ($E_i=0.003\div0.013$), fullerenes ($E_i=0.11\div0.22$), nanotubes (E_i of approximately 0.034) and other, including some unidentified

forms ($E_i=0.006\pm 0.068$), rings (E_i of approximately 0.008), and chains ($E_i=0.018\pm 0.12$), but their contents have been minor. Optimization of deposition conditions (specimen 5) has shown that the rise in contents of diamond phase (to $E_i=0.54$) in the coatings has been achievable. The latter content of diamond phase in the coating has been reached under the following PACVD process conditions: $U=900V$, $t=8min$, and $V=60cm^3/min$.

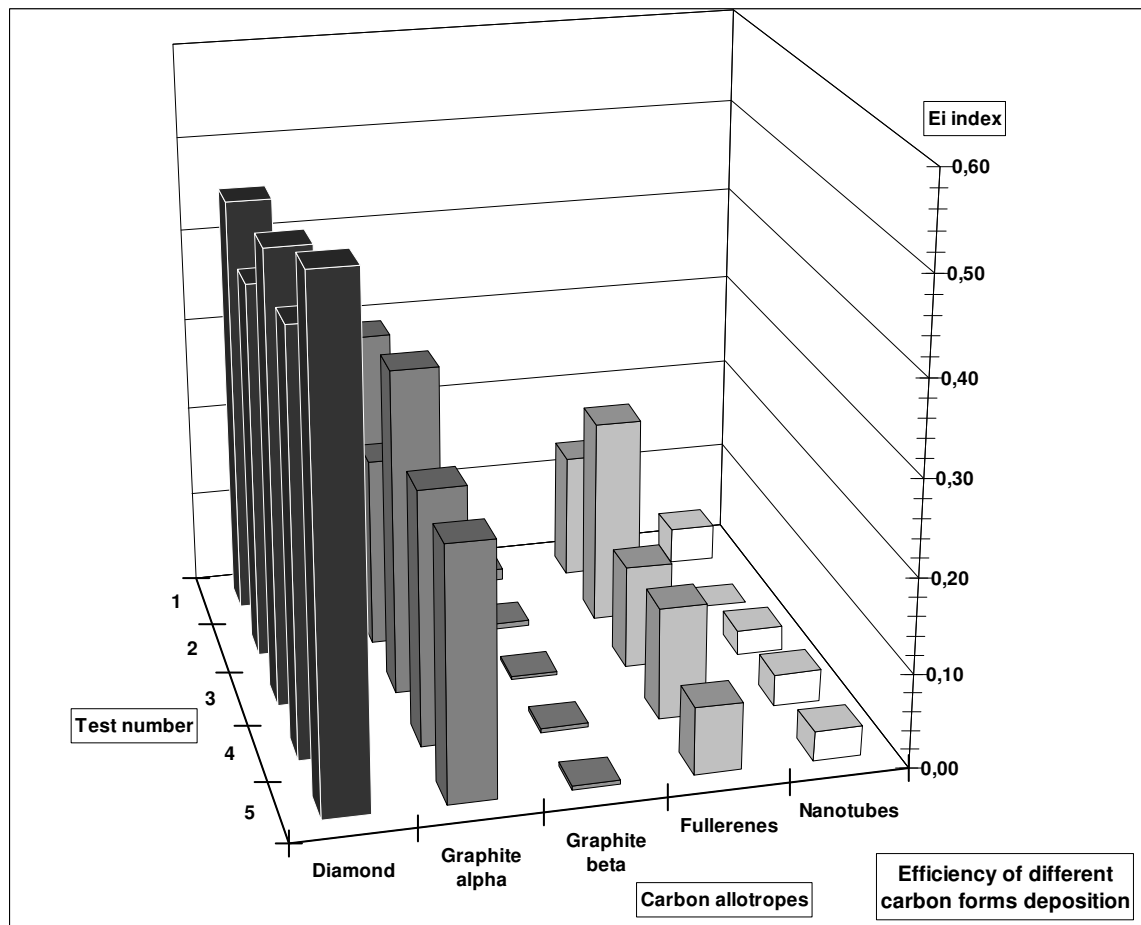

Fig. 8. Comparison of values of the relative index E_i for carbon phases identified in carbon coatings deposited on magnesium alloy specimens obtained within the scope of the planned experiments of PACVD process

7.2 Measurements of nanohardness of carbon coatings deposited on AZ31 magnesium alloy

Nanohardness of carbon coatings has been measured using Nano Test 600 meter (Micro Materials Ltd., Great Britain) equipped with a diamond pyramidal penetrator (Golabczak, 2005). The measurements of nanohardness have been conducted at the penetrating force (F) of 0.1–0.6 mN (extorted by the penetrator) and the rate of F increase (dF/dt) of 0.02 mN/s. Values of nanohardness of hard carbon coatings, measured by using the pyramidal penetrator, have been calculated as follows (2):

$$H_n = \frac{F}{24,5h_p^2} \quad (2)$$

where: H_n – nanohardness of the outer layer [GPa], F – the penetrating force [N], h_p – indentation made by the penetrator [m]. Representative results of nanohardness measurements of the examined hard carbon coatings deposited on AZ31 magnesium alloy have been shown in figure 9.

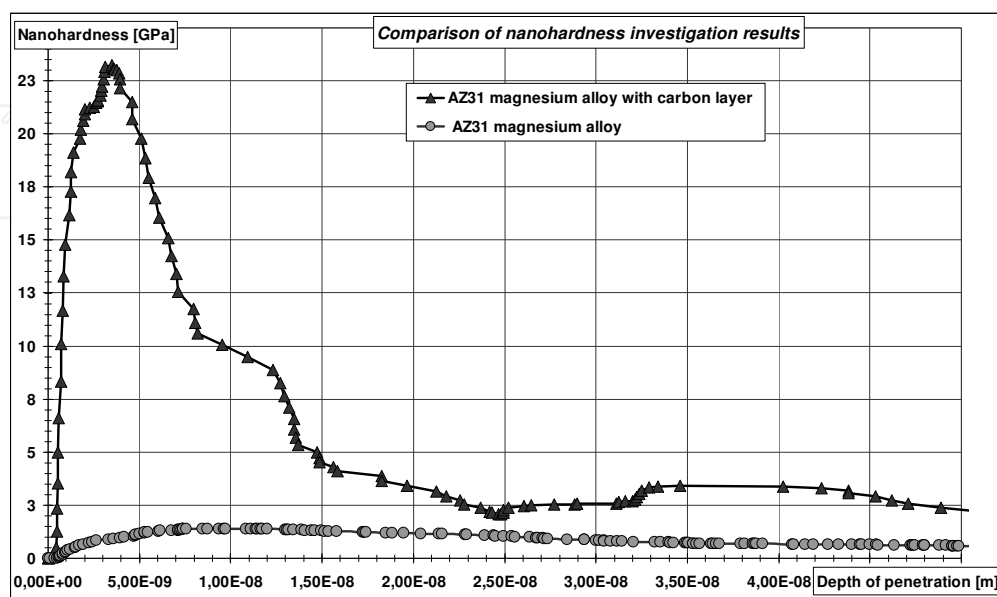

Fig. 9. Comparison of the nanohardness of AZ31 magnesium alloy protected by the carbon coating deposited under optimum conditions of PACVD process and the specimen without this coating

The latter presents the difference between the nanohardness of AZ31 magnesium alloy protected by the carbon coating deposited under optimum conditions of PACVD process and the alloy without this coating. These results provide evidence that the nanohardness of AZ31 magnesium alloy protected by the carbon coating deposited by the PACVD method has been considerably higher (24 GPa) than that of the alloy without the coating (0.8 GPa).

7.3 Determination of thickness of carbon coating

The thickness of hard carbon coatings has been determined by the method of direct profilography using the highly precise Taylor Hobson profilographometer (Golabczak, 2005, 2010). To achieve the accurate results of measurements, the carbon coatings have been deposited only on selected fragments of the examined samples of magnesium alloy. Therefore, some parts of their surface have been protected by quartz plates during synthesis of the coatings (Fig. 10). Thus the examined surfaces of magnesium alloy has contained the fragments coated by the carbon coating and free from the latter. Results of these measurements are collected in figure 11. The mean value (from 5 distinct measurements) of the thickness of a carbon coating has been approximately equal to 220 nm.

7.4 Determination of geometrical microstructure of surface and morphology of surface layer of carbon coatings

Presented investigation results concern comparison of geometrical microstructure parameters of surface and morphology of carbon coating, manufactured on AZ31 magnesium alloy samples using PACVD method, with analogous parameters of samples

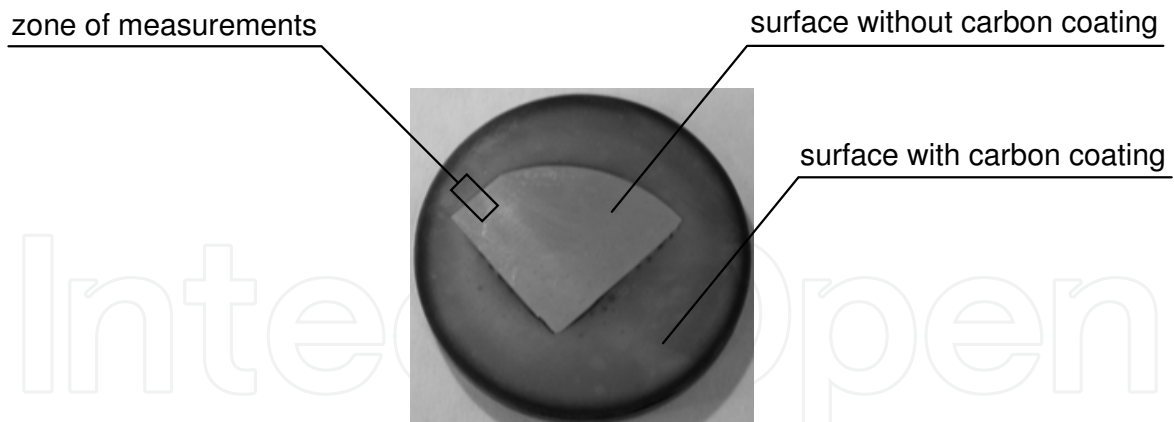

Fig. 10. The image of the surface of a specimen of magnesium alloy AZ31 prepared for the measurements of carbon coating thickness and the zone of measurements carried out by profilography method

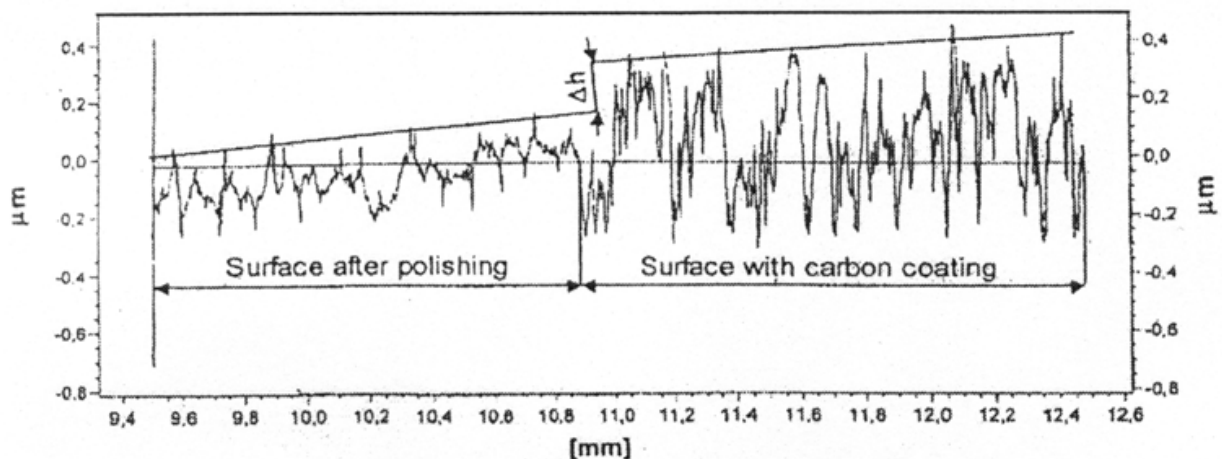

Fig. 11. Results of measurements of the thickness of carbon coating deposited on magnesium alloy AZ31 carried out by the method of direct profilography; the thickness of carbon coating (Δh) of 220 nm

without carbon coating, prepared for deposition process (after polishing process). Investigation range has included estimation of carbon coatings manufactured in optimum conditions of PACVD process (sample No. 5). Geometrical microstructure of carbon coating surface has been estimated basing on roughness and waviness parameters of surface in 2D and 3D configuration, however morphology of carbon coating basing on measurements of atomic force microscope - AFM and images of scanning electron microscope - SEM. The profile measurements have been carried out in Department of Production Engineering of Technical University of Lodz laboratory, using profilometer type PGM-1C IOS. Samples for profile measurements have been prepared in the same way like in case of thickness measurement of carbon coating (point No. 7.3). It has ensured objectivity of measurement results. Exemplary profile measurements results of samples in 2D configuration have been presented in figure 12 and 14, however in 3D configuration in figure 13 and 15. The values of roughness and waviness parameters of samples surfaces have been placed in suitable profilograms and have referred to their average value from five tests of profile measurement.

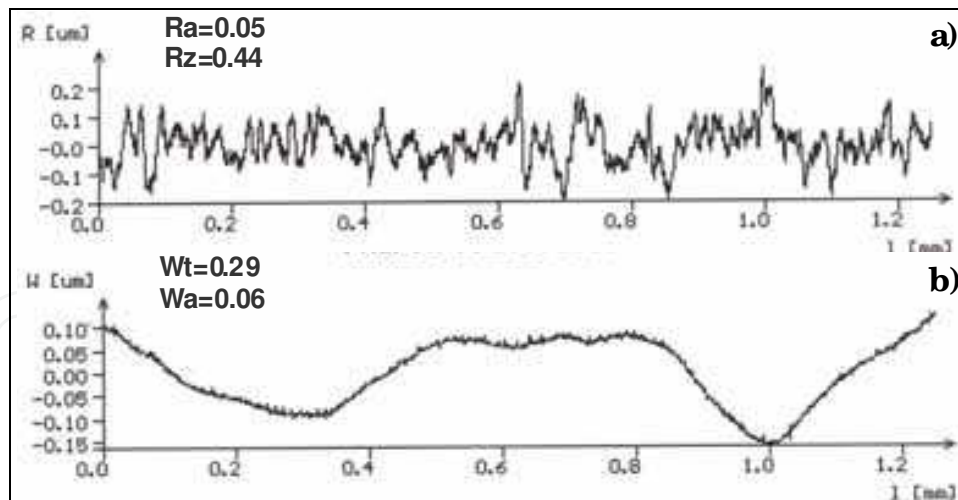

Fig. 12. Profilograms of roughness (a) and waviness (b) in 2D configuration of AZ31 magnesium alloy surface after polishing process

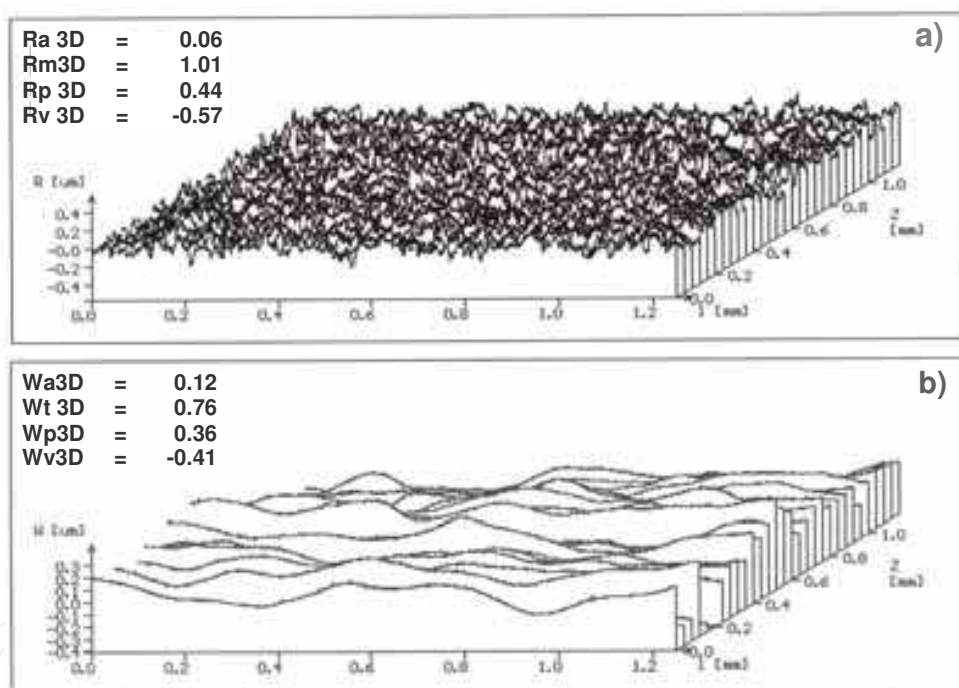

Fig. 13. Profilograms of roughness (a) and waviness (b) in 3D configuration of AZ31 magnesium alloy surface after polishing process

Roughness parameters analysis of investigated samples in 2D configuration (Fig. 12 and 14) has shown insignificant degradation of roughness of samples surfaces with carbon coating manufactured in PACVD process, compared with samples surfaces after polishing process. It has been certified increase of surface roughness, which has carried out accordingly: Ra increase equal to $0,01\ \mu\text{m}$ and Rz increase equal to $0,08\ \mu\text{m}$. However measurements carried out in 2D configuration have not revealed significant differences in values of surface waviness parameters. Roughness parameters analysis of investigated samples in 3D configuration (Fig. 13 and 15) has shown larger values of Ra , Wa and Wt parameters of investigated samples. Tendency of these changes has been like in 2D configuration

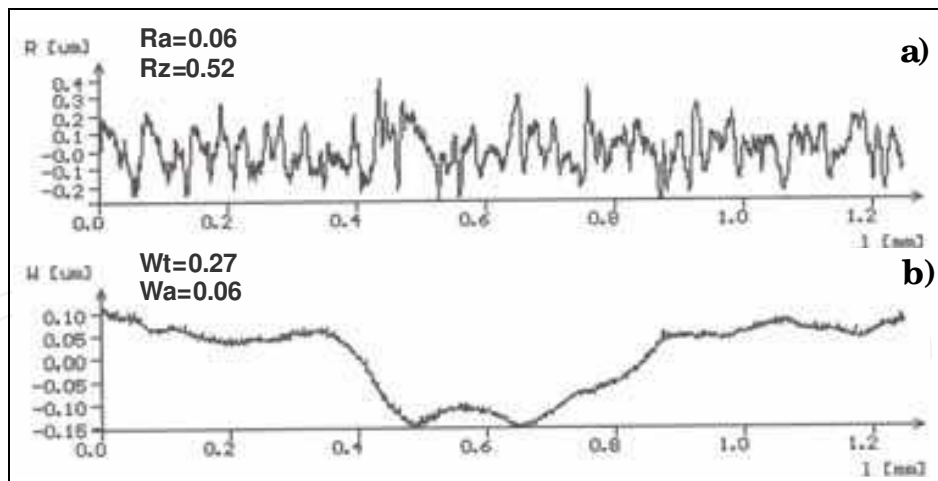

Fig. 14. Profilograms of roughness (a) and waviness (b) in 2D configuration of AZ31 magnesium alloy surface with manufactured carbon coating

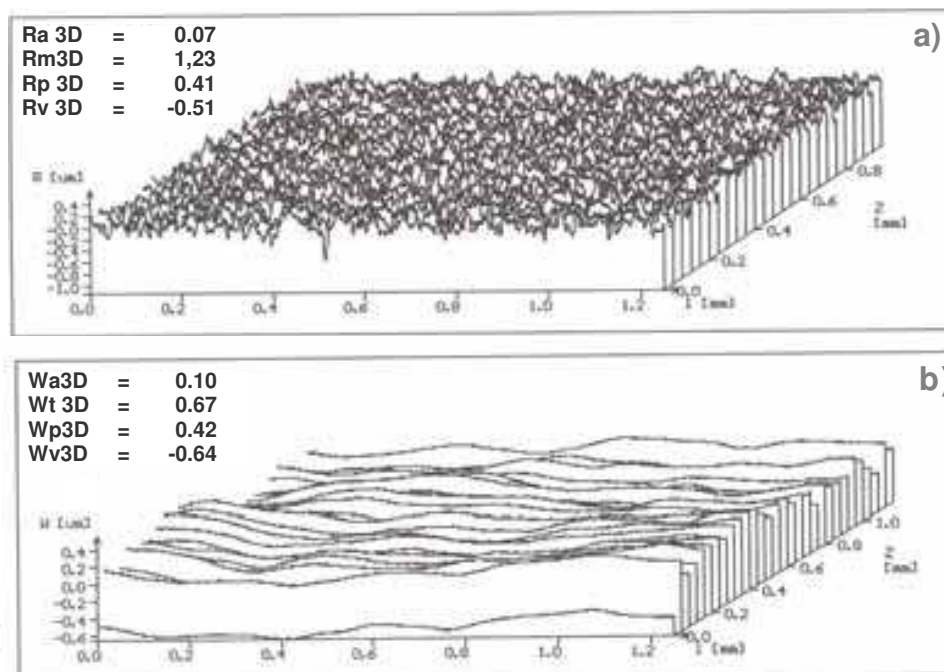

Fig. 15. Profilograms of roughness (a) and waviness (b) in 3D configuration of AZ31 magnesium alloy surface with manufactured carbon coating

measurements. Analysis of profilograms of surface roughness and waviness in 3D configuration has also revealed favourable influence of manufacturing of carbon coating using PACVD method to levelling of maximum profile elevation, expressed by a Ra parameter and maximum profile cavities, expressed by a Rv parameter. Favourable changes observed in above-mentioned measurements have been caused by random deposition of different forms of carbon forms (identified in point No. 7.1) on surface of AZ31 magnesium alloy during PACVD method. Morphology assessment of investigated samples surfaces has concerned comparison of SEM and AFM images of their surface layers, which has been shown in figure 16 and 17. These images have revealed significant changes in their

morphology of surface layer. Images of samples surfaces without carbon coatings obtained both by SEM and AFM method (Fig. 16 a and 17a) have shown presence of distinct tool marks caused by polishing process, which have been visible in form of irregular scratches on surface. SEM images of samples surfaces with manufactured carbon coating (Fig. 16 b) have been characterized by mosaic, irregular structure imaging different carbon forms in manufactured coating. Presence of these forma have been confirmed by AFM images. These different forms of carbon in manufactured coatings has had significant influence on their colours. Exemplary AFM image of surface of AZ31 magnesium alloy surface with carbon coating has been presented in figure 17 b.

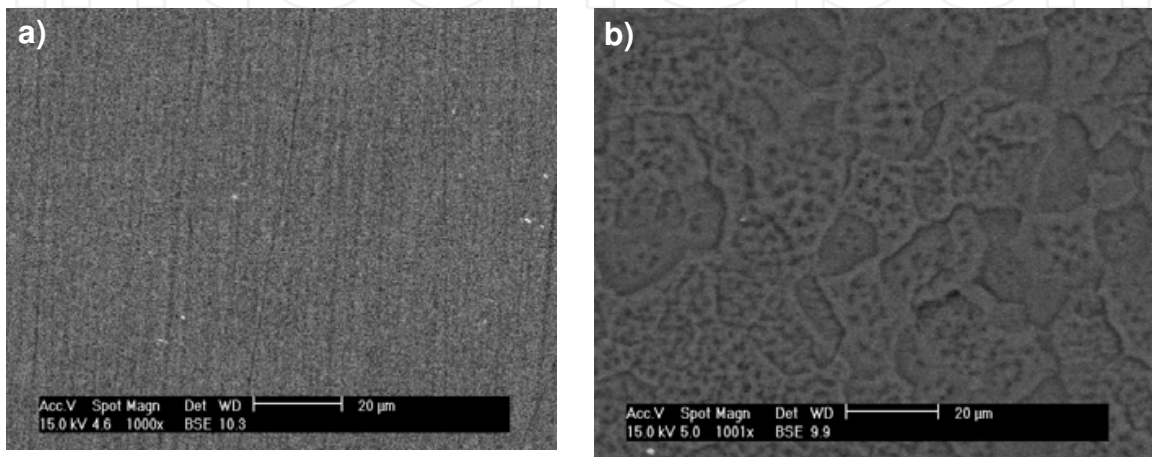

Fig. 16. Images of AZ31 magnesium alloy samples surfaces obtained by scanning electron microscope - SEM: a) surface after polishing, b) surface with carbon coating

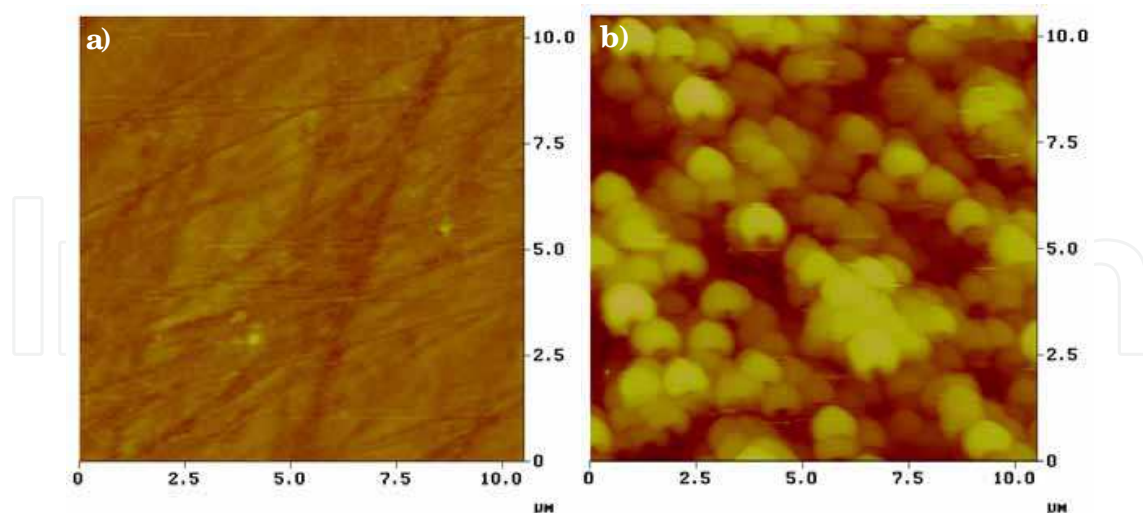

Fig. 17. Images of AZ31 magnesium alloy samples surfaces obtained by atomic force microscope - AFM: a) surface after polishing, b) surface with carbon coating

7.5 Tribologic measurements of carbon coatings

Tribologic measurements have relied on tests of rubbing interaction between rectangular specimens of AZ31 magnesium alloy covered by the carbon coating and deprived of this

layer with the cylindrical rubbers (Golabczak, 2005). The rubbers have been prepared from three different materials such as hydrogenated rubber butadiene-acrylonitrile – HNBR, poly(methylmetacrylate) – PMMA (plexiglass), and poly(tetrafluoroethylene) – PTFE (teflon). Dimensions of rectangular specimens of magnesium alloy have been 10x4x5 mm. The cylindrical rubbers has had the diameter of 35 mm and width of 10 mm. Tribologic tests have been conducted using Tribometer T-05 under the following conditions: normal load of the rubber – 6 N, the rubbing speed – 3.67 cm/ s, time of test duration – 2 h, frequency of recording of measurements – $2E+14$, and ambient temperature (T) of 20.7°C. Representative results of tribologic measurements have been shown in figure 18-19. They have presented differences in the total friction energy and volumetric wear of the examined specimens during the test. The displayed results have provided evidence that the carbon coatings deposited on magnesium alloy have considerably improved their properties. They have both reduced the total energy of friction and enhanced their resistance to wear. The experiments have revealed that the total energy of friction of the listed above specimens with carbon coatings, has been considerably lower and reached: 44% for the rubber one, 130% for the plexiglass rubber and 440% for that made of teflon. Carbon coatings have had also significantly decreased the total volumetric wear of the examined samples of magnesium alloy. The relative increase in wear resistance has been: 660% – in case of the rubber rubber, 540% – for the plexiglass rubber and 800% – for the teflon one.

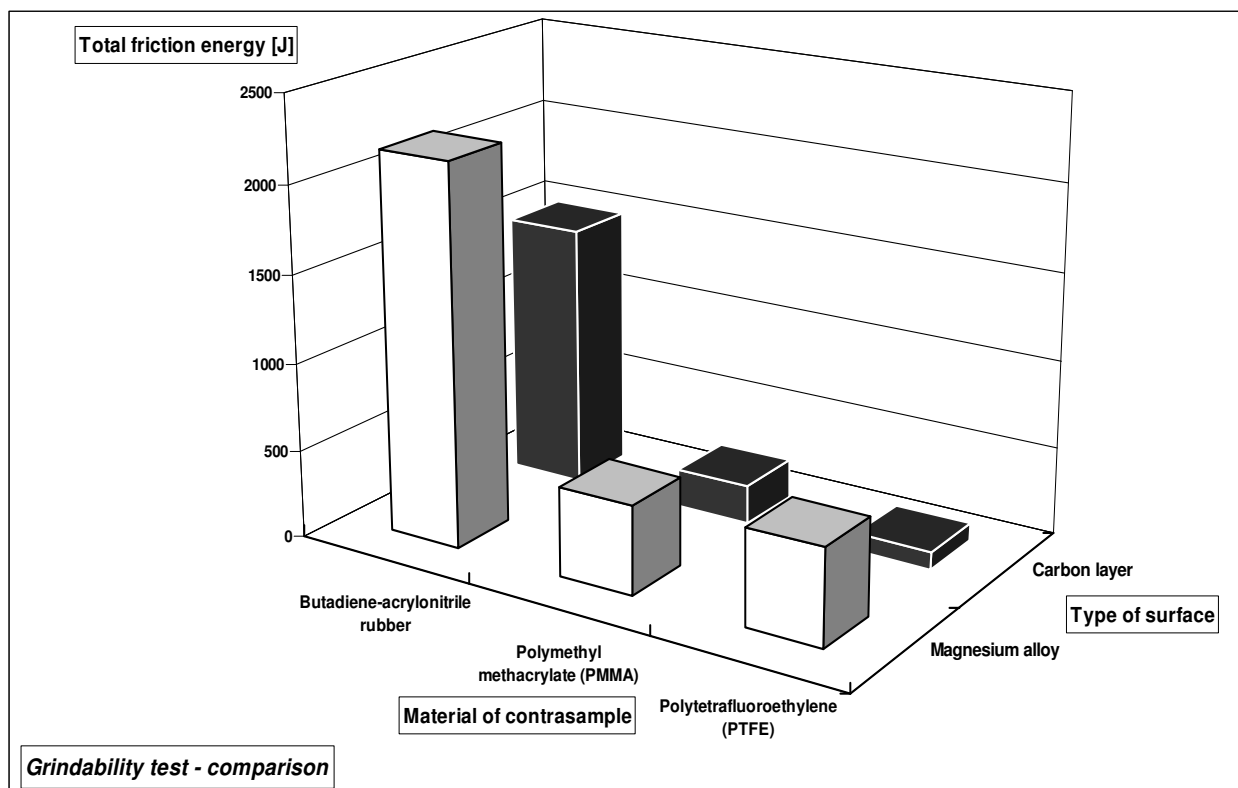

Fig. 18. Comparison of values of the total energy of friction determined by tribologic measurements for specimens made of AZ31 magnesium alloy protected by carbon coating and without the latter

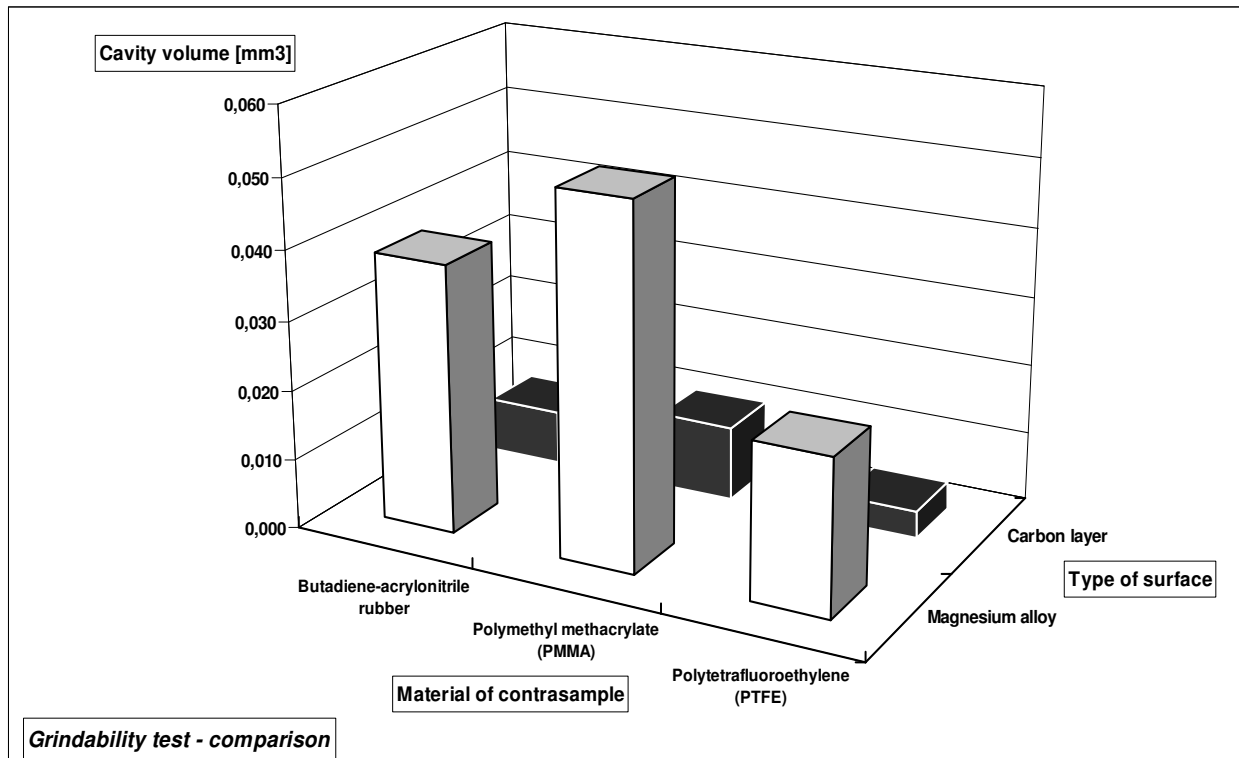

Fig. 19. Comparison of volumetric wear of the specimens made AZ31 of magnesium alloy (one covered by carbon coating and the second – without this coating) determined by tribologic measurements

7.6 Determination of corrosion resistance of hard carbon coatings in the salt spray chamber

Corrosion resistance tests of hard carbon coatings have been conducted in SIGMA DIESEL salt chamber (BOSCH). The examined specimens made of AZ31 magnesium alloy have been either protected with the carbon coating or not. Test conditions have been displayed in table 5. The samples without the carbon coating have been exposed to sodium chloride solution for 5 h while the samples protected by this coating have been exposed for 200 h (Golabczak, 2005).

Test parameters	Value
Time of test duration	5h and 200 h
Temperature in the chamber	35°C ± 1°C
Humidity in the chamber	85% - 90%
Intensity of spraying (the sprayed surface area of 80 cm ²)	2ml ± 1ml / h
Air pressure	1.0 bar ± 0.2 bar
NaCl concentration in the solution	5% (w/ v)

Table 5. Parameters of corrosion test carried out in a salt spray chamber

To estimate results of the corrosion test, images of the surface of specimens have been recorded using two microscopes, i.e. metallographic and SEM. Representative images of the surface of examined specimens have been shown in figure 20 and 21.

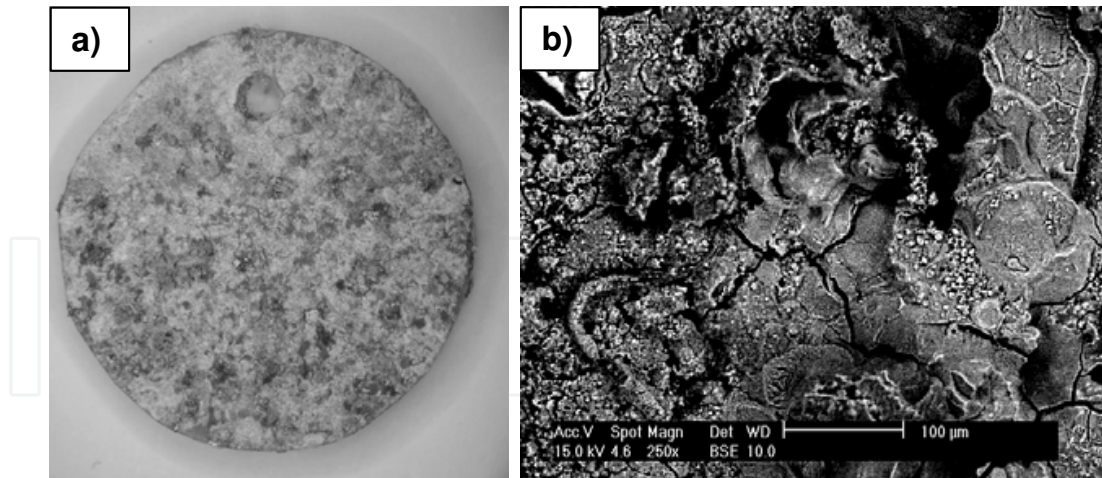

Fig. 20. Microscopic images of AZ31 magnesium alloy samples without carbon coating after 5h exposition in a salt spray chamber: a) magnification 3x, b) magnification 250x

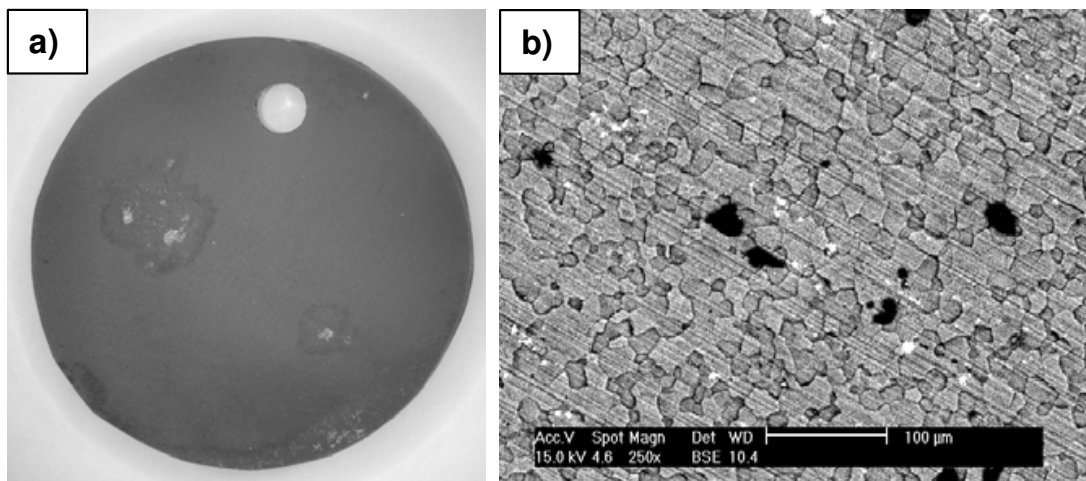

Fig. 21. Microscopic images of AZ31 magnesium alloy specimens with deposited carbon coating after 200h exposition in a salt spray chamber: a) magnification 3x, b) magnification 250x

Comparison of the images of AZ31 magnesium alloy sample surface exposed to the corroding environment in a salt chamber has shown that the samples, which have not been protected by the carbon coating have been strongly corroded after the relatively short time of exposition (5 h). In contrast, the specimens coated by the carbon film have contained only small pits of corrosion after 200 h of treatment under the same conditions. Results of these experiments have demonstrated that carbon coatings explicitly protect magnesium alloy from corrosion.

7.7 Determination of corrosion resistance of carbon coatings using electrochemical method

The accelerated electrochemical method has consisted in repeated potentiostatic measurements carried out by using Volta Master 1 set comprising a potentiostat Radiometer-Copenhagen PGP 201. The examined samples have been immersed in Tyrod's electrolyte (its chemical composition is shown in table 6) at the temperature of 20°C.

NaCl [g/ dm ³]	CaCl ₂ [g/ dm ³]	KCl [g/ dm ³]	NaH ₂ PO ₄ [g/ dm ³]	MgCl ₂ ·6H ₂ O [g/ dm ³]	NaHCO [g/ dm ³]	pH
8.00	0.20	0.20	0.05	0.10	1.00	6.9

Table 6. Chemical composition of Tyrod's electrolyte

Modeling of phenomena occurring at the contact interface between the conductor (metal) and the electrolyte has been based on the standard Butler-Volmer equation (Golabczak, 2008). It is a half-empirical equation and characterizes the rate of electric charge transfer through the interface of phases: metal-electrolyte. This rate depends, first of all, on the difference of potentials and its sign (positive or negative) at this interface. The analysis of current flow through the medium which is far from the state of equilibrium cannot be done without the model of Butler-Volmer. The model has based on an electric nonlinear circuit has been proposed to determine the flow of current in the wide range of potential values. This circuit contains some elements responsible for individual physical phenomena that take place during potentiostatic measurements. The scheme of this substitute circuit has been shown in figure 22.

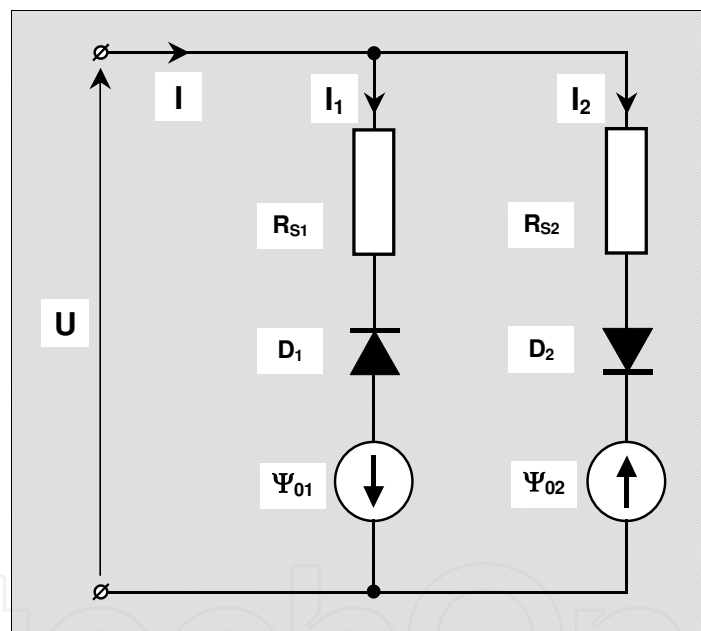

Fig. 22. The structure of proposed model in the form of the nonlinear electric circuit with lumped constants

The proposed model consists of two branches characterizing anodic and cathodic currents. Relationships between the elements of the model shown in figure 22 and phenomena occurring at the interface conductor-electrolyte are as follows:

- diodes D_1 and D_2 that are fundamental elements of the proposed model correspond to the exponential components of Butler-Volmer equation that are responsible for diffusion,
- resistors R_{S1} and R_{S2} are responsible for the transfer of electric charge carriers and are particularly important at higher values of voltage U ,
- voltage generators Ψ_{01} and Ψ_{02} are responsible for the difference in potentials at the contact interface for anodic and cathodic parts of the characteristics.

Equations describing the substitute electric circuit (Fig. 22) are as follows:

- for the anodic branch (left parts of descending curves in figure 23 and 24):

$$j_1 = -j_{01} \left(e^{\frac{q \cdot m_1}{k \cdot T} \cdot U_{D1}} - 1 \right) \quad (3)$$

$$R_{S1} \cdot j_1 + U_{D1} + \Psi_{01} = U \quad (4)$$

- for the cathodic branch (right parts in ascending curves in figure 11 and 12):

$$j_2 = j_{02} \left(e^{\frac{q \cdot m_2}{k \cdot T} \cdot U_{D2}} - 1 \right) \quad (5)$$

$$R_{S2} \cdot j_2 + U_{D2} + \Psi_{02} = U \quad (6)$$

The total current flowing through the interface is the sum of anodic current and cathodic current:

$$j = j_1 + j_2 \quad (7)$$

where: q - the elementary charge of an electron, expressed in [C] [A·s], $q=1.6022 \cdot 10^{-19}$ C;

k - Boltzman constant, expressed in [J K] [kg·s²/ m²·K], $k=1.3807 \cdot 10^{-23}$ J K;

T - the temperature of the contact interface [K];

j_{01}, j_{02} – the density of saturation currents, expressed in [mA/ cm²];

R_{S1}, R_{S2} – resistances representing the phenomenon of electron transfer, expressed in [Ω];

m_1, m_2 – coefficients dependent on division of currents and valences of ions in the electrolyte, dimensionless quantities.

Electric parameters of this model for individual potentiostatic curves (Tafel curves) have been identified by means of the least square method and by resolving the system of nonlinear equations by the gradient method. The obtained parameters are effective estimators of the true model parameters. Results of potentiostatic measurements have been plotted in figure 23 and 24. Intercepts of curves presenting the voltage on diodes with OX axis correspond to potentials on the interface metal-solution. The values of electric parameters that have been calculated for the assumed models are presented in table 7 and 8. On completion of potentiostatic measurements the surface of the examined samples has been subjected to SEM analysis. Examples of the recorded images have been shown in figure 25 and 26. Analysis of results of electrochemical studies has revealed that deposition of the carbon coating on the surface of AZ31 magnesium alloy significantly dislocated and increased the difference in potentials (corrosion potential increased) at the interface between the metal and solution (Fig. 24) as compared to the reference sample without the coating (Fig. 23). It provides evidence of the beneficial effect of carbon coating deposited on this alloy because the barrier protecting the latter from electrochemical corrosion has been increased.

Also SEM analysis of the surface of the examined samples has confirmed this desirable impact (Fig. 25 - 26). Only single dark spots (probably very small corrosion pits) have been visible at the surface of the samples coated by carbon coating (Fig. 26) whereas harmful results of electrochemical corrosion have been visible on the whole surface of unprotected AZ31 magnesium alloy (Fig. 25).

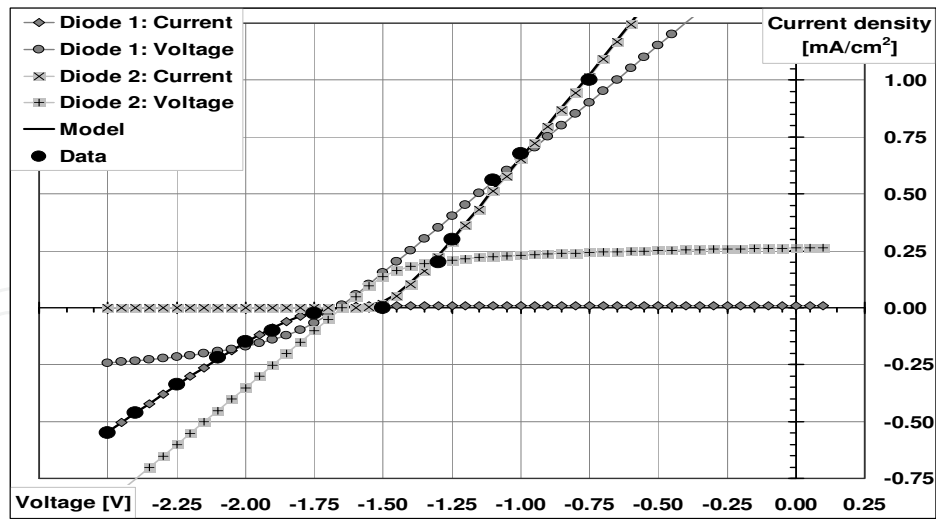

Fig. 23. Potentiostatic curve of electrochemical corrosion for AZ31 magnesium alloy free of carbon coating

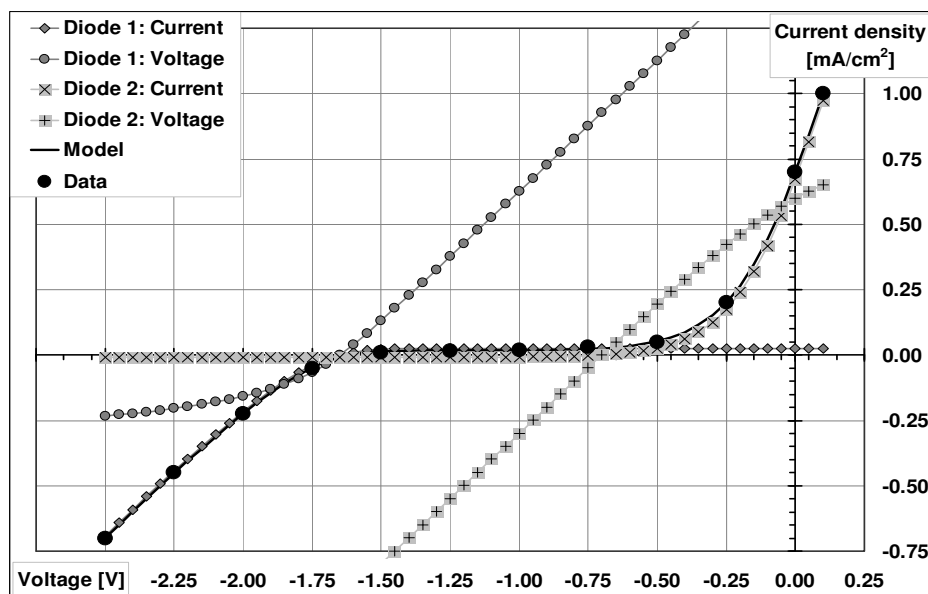

Fig. 24. Potentiostatic curve of electrochemical corrosion for AZ31 magnesium alloy protected by carbon coating

Model parameters	J_0	Ψ_0	m	R_s
	mA/cm^2	V	-	Ω
Diode I	0.009145	-1.6622	0.4276	1092.46
Diode II	0.000100	-1.6482	0.9607	643.96
Fitting error	4.027E-03			
Deviation 3σ	5.280E-02			mA/cm^2

Table 7. Electric parameters of the potentiostatic curve of electrochemical corrosion for sample made of AZ31 magnesium alloy free of carbon coating

Model parameters	J_0	Ψ_0	m	R_s
	mA/cm^2	V	-	Ω
Diode I	0.026058	-1.6501	0.3588	892.26
Diode II	0.008067	-0.7000	0.1867	152.36
Fitting error	7.947E-05			
Deviation 3σ	7.720E-03			mA/cm^2

Table 8. Electric parameters of the potentiostatic curve of electrochemical corrosion for sample made of AZ31 magnesium alloy coated by carbon coating

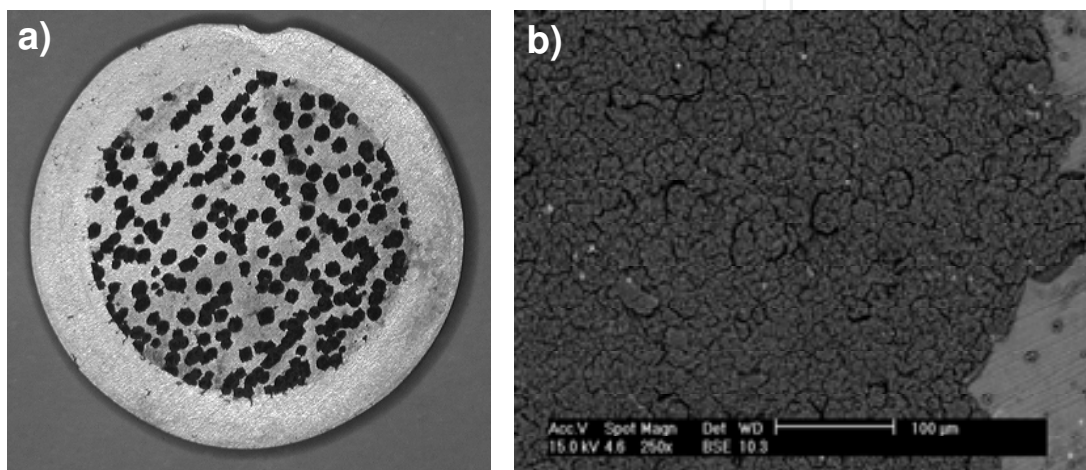

Fig. 25. SEM image of AZ31 magnesium alloy surface on completion of the potentiostatic corrosion test; test duration - 1h: a) magnification 3x, b) magnification 250x

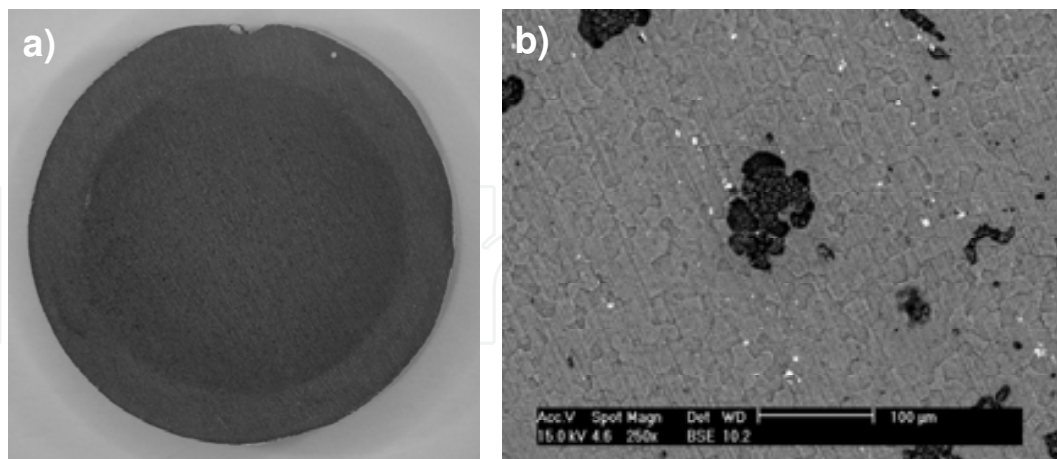

Fig. 26. SEM image of the surface of AZ31 magnesium alloy protected by carbon coating on completion of the potentiostatic corrosion test; test duration 1h: a) magnification 3x, b) magnification 250x

7.8 Determination of adhesion of carbon coatings

Adhesion measurement of carbon coating to magnesium alloy substrate has been carried out using scratch tester. The scratch tester is a common method of testing the adhesion of

coatings to substrates. For this purpose a special diamond intender is used. The load on the diamond causes stresses to be increased at the interface between the coating and the substrate that can result in delamination of the coating to occur. The load at which the coating first delaminates is called the critical load. For measurement of carbon coating a small diamond intender with a radius of $r=200\ \mu\text{m}$ has been applied. During test a diamond intender has been scratched across the coated surface of a substrate at a constant velocity whilst a load has been applied with a constant loading rate F . Applied load F has been changed in the 10 to 30 N range and the load rating has been equal to 5 N. Adhesion assessment of carbon coating to magnesium alloy substrate has been done basing on optical microscope images of wear tracks of worn surfaces of the sample. The critical load of intender F_c , at which occurs cohesion loss has been assumed as criterion of adhesion of the coating to substrate. For ascertainment of this fact the comparison of microscopic images of wear tracks of worn surface of AZ31 magnesium alloy protected by carbon coating has been done (Fig. 27).

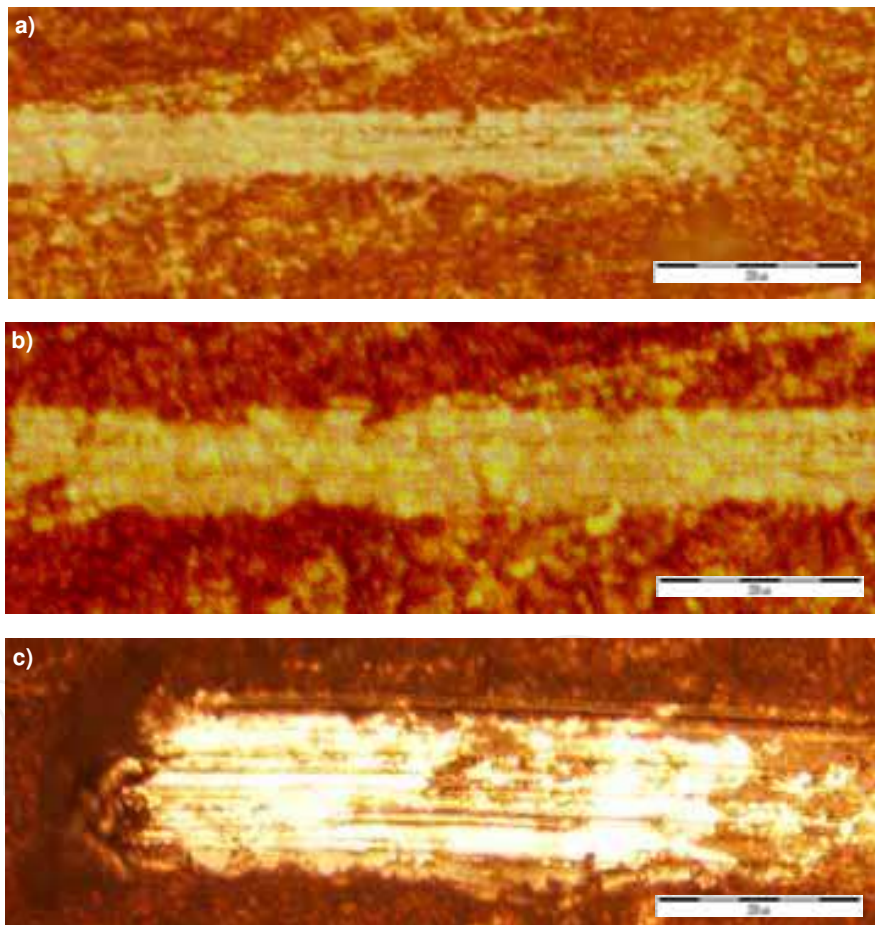

Fig. 27. Characteristic images of wear tracks of worn surface of sample after „scratch test” obtained using optical microscope (magnification 50 x): a) $F= 10\ \text{N}$, b) $F= 20\ \text{N}$, c) $F= 25\ \text{N}$

Presented investigation results have concerned adhesion of carbon coatings manufactured in optimum conditions of PACVD process, i.e. in conditions of test No. 5. Basing on investigations carried out it has been certified that critical load of intender F_c at which occurs no cohesion loss between carbon coating and magnesium alloy substrate has been

equal to 20 N (Fig. 27 b). Further increase load of indenter (to 25 N) has caused separation of carbon coating from magnesium alloy substrate. This state has been presented in figure 27 c, where sharply outlined surface and white zone of magnesium alloy have been visible.

8. Conclusion

Investigations carried out have confirmed that Plasma Activated Chemical Vapour Deposition (PACVD) method enables deposition of protective carbon coatings on AZ31 magnesium alloy. Elaborated technological polishing process of AZ31 magnesium alloy samples has ensured suitable preparation their surfaces, in range of required roughness parameters and their proper purity. Investigations results have confirmed that content of diamond phase in these coatings has been very high. Its relative index E_i has been equal to 0.54 and has depended on PACVD process conditions. Nanohardness of magnesium alloy AZ31 protected by the carbon coating has been considerably higher (24 GPa) than that of the alloy without this coating (0.8 GPa). The measured thickness of a carbon coating has been approximately equal to 220 nm. The displayed results have provided evidence that the carbon coatings deposited on magnesium alloys have considerably improved their properties. They have both reduced the total energy of friction and enhanced their resistance to wear. The experiments have revealed that the total energy of friction of the listed above specimens with carbon coatings, has been considerably lower and reached: 44% for the rubber one, 130% for the plexiglass rubber and 440% for that made of teflon. Carbon coatings have also significantly decreased the total volumetric wear of the examined samples of magnesium alloy. The relative increase in wear resistance has been: 660% – in case of the 540% - for the plexiglass and 800% - for the teflon one. Experiments have demonstrated that carbon coatings explicitly protect magnesium alloy from “salt spray” corrosion and electrochemical corrosion. Basing on investigations carried out it has been certified that critical load of indenter F_c at which occurs no cohesion loss between carbon coating and magnesium alloy substrate has been equal to 20 N. Manufactured carbon coatings apart from very attractive operational properties mentioned above, have had also decorative properties. They have had gold glossy colour what can be useful in making of jewellery. Moreover, manufactured carbon coatings have been characterized by very good biocompatibility (because of high content of pure diamond). This property is especially important in protection of implants surfaces. Presented results have indicated that the studies should be continued in order to improve PACVD method and produce carbon coatings on specimens with more complex shapes and on internal surfaces of specimens made of magnesium alloys.

9. Acknowledgement

This work has been partially financed by the Grant No. 3 T08C 06826 from Polish Committee for Scientific Research.

10. References

Clapa, M.; Mitura, S; Niedzielski, P; Karczewska, A. & Hassard, J (2001). *Diamond and Related Materials*, Vol. 10, No. 3, pp. 1121-1124

- Golabczak M. (2005). *Manufacturing of Carbon Coatings on Magnesium Alloys by PACVD Method*, Technical University of Lodz, Poland.
- Golabczak, M. (2007). *Advances in Manufacturing Science and Technology*, Vol. 31, No. 2, pp. 81-90 ISSN 1895-9881
- Golabczak, M. (2008). *Mechanics and Mechanical Engineering*, Vol. 12, No 2, pp. 157-164, ISSN 1428-1511
- Golabczak, M. & Konstantynowicz, A. (2009). *Journal of Achievements in Materials and Manufacturing Engineering*, Vol. 37, pp. 270-276
- Golabczak, M. & Konstantynowicz, A. (2010). *Defect and Diffusion Forum*, Vols. 297-301, pp. 641-649, ISSN 1012-0386
- Golabczak, M. (2010). *Advanced Knowledge Application in Practice*, Sciyo, ISBN 978-953-307-141-1, Rijeka, Croatia
- Gray, J.E. & Luan, B. (2002). *Journal of Alloys and Compounds*, Vol. 336, No 1, pp. 88-113, ISSN 0925-8388
- Hawkins, J.H. (1993). *Global View Magnesium: Yesterday, Today, Tomorrow*, International Magnesium Association, pp. 46-54
- Ida, T.; Ando M. & Toraya H. (2000). *Journal of Applied Crystallography*, Vol. 33, pp. 1311-1316
- Ishizaki, T.; Shigematsu, I. & Saito, N. (2009). *Surface & Coatings Technology*, Vol. 203., No. 16, pp. 2288-2291, ISSN 0257-8972
- Kawalla, R.; Lehmann, M. & Ullmann, M. *Archives of Civil and Mechanical Engineering*, Vol. VIII, No. 2, pp. 93-101, ISSN 1644-9665
- Kuc, D.; Hadasik, E.; Niewielski, G. & Plachta, A. (2008). *Journal of Achievements in Materials and Manufacturing Engineering*, Vol. 27, pp. 27-30
- Niedzielski, P.; Mitura, E.; Mitura, S. et al. (1997). *Diamond and Related Materials*, Vol. 6, No. 5, pp. 721-724
- Olszyna, A. & Smolik, J (2004). *Thin Solid Films*, Vol. 459, No 1/ 2, pp. 224-227
- Robertson, J (2002). *Materials Science and Engineering*, Vol. 37, 2002, pp. 129-281
- [http:// bbs.com](http://bbs.com) (2008)
- [http:// buehler.com](http://buehler.com) (2010)
- [http:// olympus.com](http://olympus.com) (2011)

IntechOpen

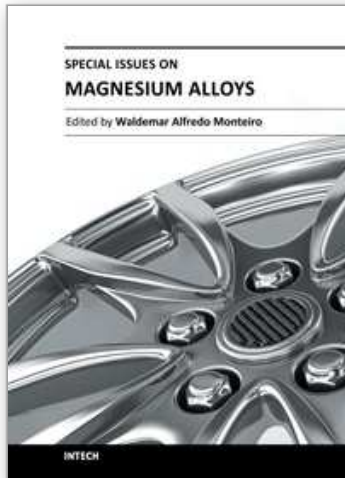

Special Issues on Magnesium Alloys

Edited by Dr. Waldemar Monteiro

ISBN 978-953-307-391-0

Hard cover, 128 pages

Publisher InTech

Published online 12, September, 2011

Published in print edition September, 2011

Magnesium is the lightest of all the metals and the sixth most abundant on Earth. Magnesium is ductile and the most machinable of all the metals. Magnesium alloy developments have traditionally been driven by requirements for lightweight materials to operate under increasingly demanding conditions (magnesium alloy castings, wrought products, powder metallurgy components, office equipment, nuclear applications, flares, sacrificial anodes for the protection of other metals, flash photography and tools). The biggest potential market for magnesium alloys is in the automotive industry. In recent years new magnesium alloys have demonstrated a superior corrosion resistance for aerospace and specialty applications. Considering the information above, special issues on magnesium alloys are exposed in this book: casting technology; surface modification of some special Mg alloys; protective carbon coatings on magnesium alloys; fatigue cracking behaviors of cast magnesium alloys and also, magnesium alloys biocompatibility as degradable implant materials.

How to reference

In order to correctly reference this scholarly work, feel free to copy and paste the following:

Marcin Golabczak (2011). Estimation of Carbon Coatings Manufactured on Magnesium Alloys, Special Issues on Magnesium Alloys, Dr. Waldemar Monteiro (Ed.), ISBN: 978-953-307-391-0, InTech, Available from: <http://www.intechopen.com/books/special-issues-on-magnesium-alloys/estimation-of-carbon-coatings-manufactured-on-magnesium-alloys>

INTECH
open science | open minds

InTech Europe

University Campus STeP Ri
Slavka Krautzeka 83/A
51000 Rijeka, Croatia
Phone: +385 (51) 770 447
Fax: +385 (51) 686 166
www.intechopen.com

InTech China

Unit 405, Office Block, Hotel Equatorial Shanghai
No.65, Yan An Road (West), Shanghai, 200040, China
中国上海市延安西路65号上海国际贵都大饭店办公楼405单元
Phone: +86-21-62489820
Fax: +86-21-62489821

© 2011 The Author(s). Licensee IntechOpen. This chapter is distributed under the terms of the [Creative Commons Attribution-NonCommercial-ShareAlike-3.0 License](#), which permits use, distribution and reproduction for non-commercial purposes, provided the original is properly cited and derivative works building on this content are distributed under the same license.

IntechOpen

IntechOpen