

We are IntechOpen, the world's leading publisher of Open Access books Built by scientists, for scientists

4,800

Open access books available

122,000

International authors and editors

135M

Downloads

Our authors are among the

154

Countries delivered to

TOP 1%

most cited scientists

12.2%

Contributors from top 500 universities



WEB OF SCIENCE™

Selection of our books indexed in the Book Citation Index
in Web of Science™ Core Collection (BKCI)

Interested in publishing with us?
Contact book.department@intechopen.com

Numbers displayed above are based on latest data collected.
For more information visit www.intechopen.com



Casting Technology and Quality Improvement of Magnesium Alloys

By Hai Hao
*Dalian University of Technology,
China*

1. Introduction

Magnesium alloys offer the potential for weight and related energy savings in both the automotive and aerospace industries as they have the highest strength-to-weight ratio of common structural metals. Despite higher cost, this potential benefit has led to a recent increase in demand on cast and wrought magnesium products. This chapter will talk about numerical simulation work and technology related to magnesium casting process. And it includes four topics:

1. The fundamentally-based mathematical models to predict the temperature and stress evolution in both the billet as well as the dummy block during the DC casting of wrought magnesium alloy billets;
2. The application of EPM(Electromagnetic Processing of Materials) on the magnesium alloys;
3. High intensity ultrasonic treatment to improve the solidification structure of magnesium alloys;
4. The effects of grain refiner and the external fields on grain size and microstructure of magnesium alloys.

2. Research on modeling of magnesium DC casting

Direct chill (DC) casting of billets, shown schematically in Fig.1, is the main process for producing the precursor material for many nonferrous (i.e., zinc, aluminum, and magnesium) wrought products as well as the remelt stock for cast products [1]. During this process, molten metal is initially poured onto a dummy block located inside a water cooled mould. When the metal reaches a predetermined height inside the mould, the dummy block is lowered at a controlled speed. As the freshly solidified billet comes out of the mould, water is sprayed on the newly exposed surface. The DC casting process has found extensive acceptance in the light metals industry, especially for aluminum, as a reliable and economic production method, involving low capital investment, simple operating features and great product flexibility. During the 1990s, industry, especially the automotive industry, rediscovered magnesium and took advantage of its remarkable properties, especially low density, to reduce weight and improve fuel economy. Magnesium also found new applications in hand tools and, most recently, in portable electronic equipment. Due to its weight-saving benefit, high mechanical properties, high damping capacity, and

electromagnetic shielding, increasing markets of magnesium components are, resulting in the need for greater scientific and technical understanding of magnesium and magnesium casting process.

Although the DC casting process has been the subject of scientific study since its beginning in the 1930s and has been used almost exclusively to produce aluminum ingots/billets and more recently magnesium billets, there is still work necessary to optimize the design of the casting process from the standpoint of productivity, cost effectiveness, and final ingot quality. One of the challenges in optimization is the complex interaction between the casting parameters, such as withdrawal rate, water flow rate, dummy block design, and defect formation, which is difficult to rationalize experimentally. One approach overcome this problem is to use fundamentally based mathematical models to analyze defect formation such as hot tearing, cold cracking, bleed outs, and cold shuts because most are directly related to heat flow and deformation phenomena. While this trend is growing in popularity, it hinges on the ability to predict the temperature evolution and subsequent thermal stress during the casting process. Over the years, computer modeling has provided a powerful means to investigate and understand the evolution of thermal and mechanical phenomena during the DC casting process.

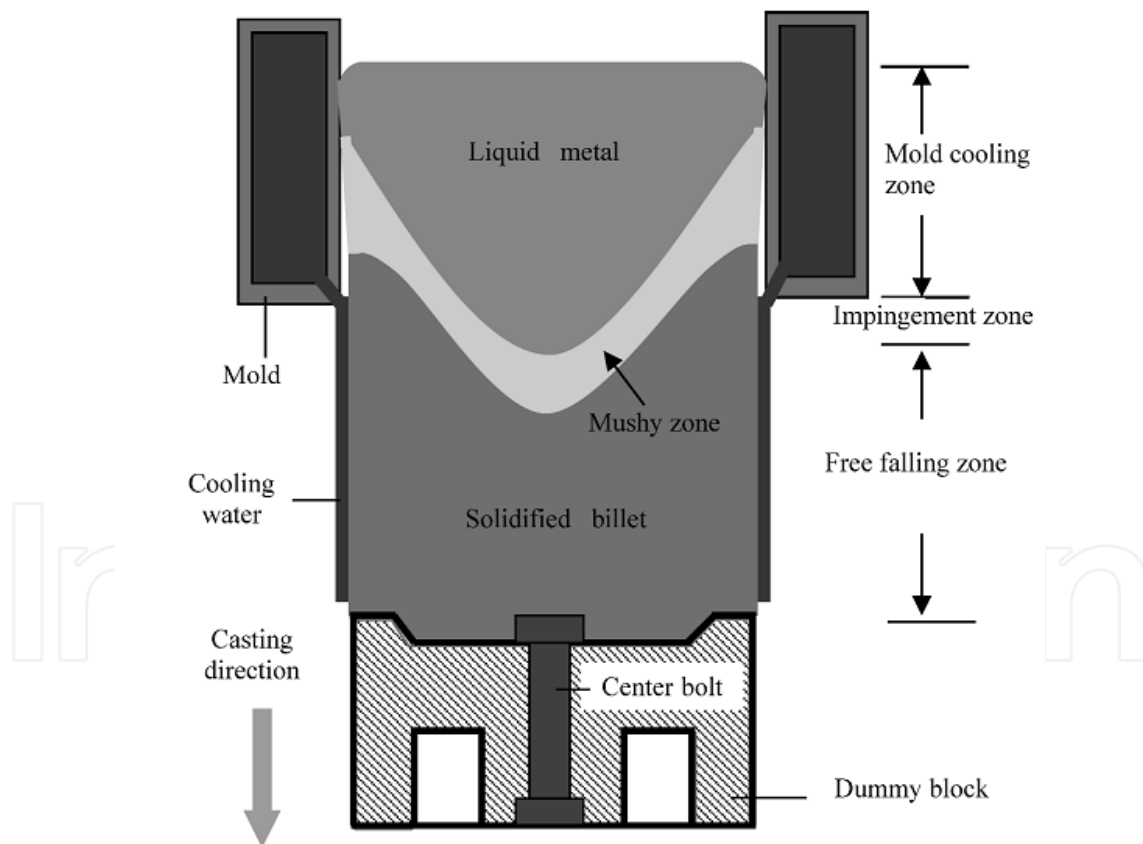

Fig. 1. Schematic DC casting process used for magnesium billet casting

Mathematical modeling of the DC casting process using various techniques has been underway since 1940^[2]. The earliest published mathematical model of DC casting using a computer to solve the heat conduction equation numerically was published by Adenis et al.

in 1962^[3]. In this work, the steady-state temperature distribution in DC casting magnesium alloy billets was calculated using a two-dimensional (2-D) axisymmetric heat-transfer model with heat-transfer coefficient boundary conditions. The heat-transfer coefficient boundary conditions described the separation between the billet and mold during primary cooling and the contact with water below the mold. Following this early work, interest appears of articles have been published on aluminum DC casting since the 1970s compared with only a few articles on magnesium.

The other research on modeling magnesium DC casting, besides Adenis et.al, was published by Hibbins^[4]. In this work, 2-D axisymmetric and three-dimensional (3-D) steady-state heat-transfer models were developed for DC casting of AZ31 magnesium alloy using the finite-difference numerical method. The models were used to predict the steady-state temperature profiles in billets and blooms under variety of casting conditions. A series of constant heat-transfer coefficient boundary conditions, calculated based on experimental temperature measurements, were used to describe the primary and secondary cooling regions. Specifically, the primary cooling heat-transfer coefficients were reduced from 35000 to 300 W/m²/K at fixed positions within the mold to reflect the air gap formation. Constant heat-transfer coefficients of 10,000 to 12,000 W/m²/K were defined in the impingement and free falling sections of the secondary cooling region. The resulting model predictions show good agreement across different casting conditions, but the use of constant heat-transfer boundary conditions and fixed length heat-transfer zones in the primary and secondary cooling regions limits the applicability of this model to a wide range of casting conditions.

A review of the published literature on aluminum DC casting reveals that early modeling efforts adapted Adenis et al.'s work to describe the 2-D steady-state temperature distribution in aluminum alloy billets^[2,5]. However, heat-transfer models with increased sophistication soon followed including those that considered transient heat conduction, 3-D geometry and complex boundary conditions. Within this published body of work, some of these models have ignored the presence of the bottom block, choosing to describe the interfacial heat transport along the base of the ingot as a heat-transfer coefficient boundary condition with a fixed far-field temperature, while others have included the dummy or bottom block and have described the interfacial heat transfer between the billet and bottom block as a function of base deformation, which is assumed to evolve during casting^[6].

In terms of secondary cooling, boiling water heat transport has typically been described by an effective heat-transfer coefficient, which is a nonlinear function of surface temperature and vertical position on the billet surface^[7]. Other advancements include correlations that are a function of water flow rate and impingement point temperature and include the effect of water ejection^[8]. The most recent thermal models of aluminum DC casting have been coupled with fluid flow and deformation models to understand and describe inter-related transport phenomena, such as water incursion below the base of the ingot^[9].

Another trend that is emerging in the aluminum DC casting literature related to hot tearing and include not only the development of criteria and models to predict the onset of hot tearing but their implementation within DC casting thermal/stress models. A recent publication by Drezet and Rappaz et al. has successfully used a pressure based hot tear model to predict hot tearing in the center of aluminum billets in proximity to the base^[10].

Typical defects that occur during DC casting include both hot tearing and cold cracking that can lead to downstream defects during subsequent processing operations, and are major difficulties which restrict the productivity of the process and its variability of alloys and ingot size. Investigations focusing on hot tearing indicate that these tears are likely

generated when thermally induced stresses are applied to regions of the billet that are at or above the solidus temperature. During billet casting, metal starts solidifying from the outer surface to the center of the billet because the outer surface is being cooled by the cooling water. After the outer shell has contracted upon freezing, the inner metal tries to contract as it freezes. Because of the difference in the contraction from the surface to the center of the billet due to the differences in temperature gradient, internal thermal stress development. The temperature gradient, internal thermal stresses develop. The internal stress cause hot tears when these stresses exceed the flow stress limit of the alloy being cast. On the other hand, the stress may persist in the billet even though in the absence of temperature gradient, which is called residual stress, and can cause cold cracking. Overall, understanding the evolution of thermal stress is a prerequisite to solve the cracking problems.

In Hao's work, a previously developed axisymmetric model describing the evolution of temperature during the DC casting of magnesium AZ31 billets has been extended to predict the evolution of stress and strain in order to predict the susceptibility of the process to hot tearing using the Rappaz-Drezet-Gremaud(RDG) criterion^[11]. The as-cast constitutive behavior of the AZ31 alloy was established from compression experiments made using a Gleeble 3500 thermo literature. Residual strains/stresses on an as-cast billet combined with process deformation data can provide the data necessary to validate the mechanical model.

2.1 Measurement of residual strains in magnesium billets

As mentioned above, DC cast products experience thermal strains because of the shrinkage during the casting process. The thermal strains result in residual stresses after final cooling to ambient temperature. While it is difficult to investigate the stress state of the hot strand during the casting process, the residual stress state of the cold material can be analyzed by several experimental methods, classified as fully destructive, partly and non-destructive techniques.

The partially or fully destructive, or so called 'mechanical' techniques generally involve removal of material by drilling, cutting, slitting or sectioning combined with strain gauge measurements^[12-13]. These methods give bulk residual strain values, but suffer the disadvantages of involving destruction of the component, and are usually limited to symmetrical components to avoid uncertainties.

The non-destructive or so called 'physical methods', mainly include ultrasonic and diffraction technique. The former method uses the electromagnetic-acoustic transducer as an 'ultrasonic strain gauge' to measure the strains. The diffraction techniques usually utilize X-rays or neutrons to measure strain states and are suitable for investigating specimens made from polycrystalline materials. Both X-ray and neutron diffraction methods measure directly changes in the lattice spacing of crystals then obtain the strain components. Residual stresses are then calculated from these strains in a similar way to those from strain gauge readings. The X-ray technique is now well known but X-rays interact with orbiting electrons and are strongly absorbed after penetrating a very small depth in most metals, making them suitable for the measurement of surface strains but not for bulk measurements. The more recent technique of neutron diffraction enables non-destructive internal strain measurements to be made, sometimes at depths of several centimeters due to the great penetrating power of the neutrons.

Since neutrons have wavelike properties they can be diffracted by the scattering object that has length scales comparable to the neutron beam wavelength. Taking advantage of the weak interaction of the uncharged neutron with electrons, which allows them to penetrate

several centimeters into most metals, the neutron diffraction technique provides means to investigate bulk strains in metal components^[14-15].

Hao et al. ^[16] presented the strain distributions along radial, axial and hoop directions in a direct chill cast billet of AZ31 magnesium alloy by neutron diffraction, which provide the data necessary to validate a thermo-mechanical model that predicts the evolution of stress/strain during the DC casting and subsequently to investigate the cracking defects in the billets. Schematic view of the billet orientation for radial strain measurement with respect to the incident and diffracted beams is shown in Fig.2.

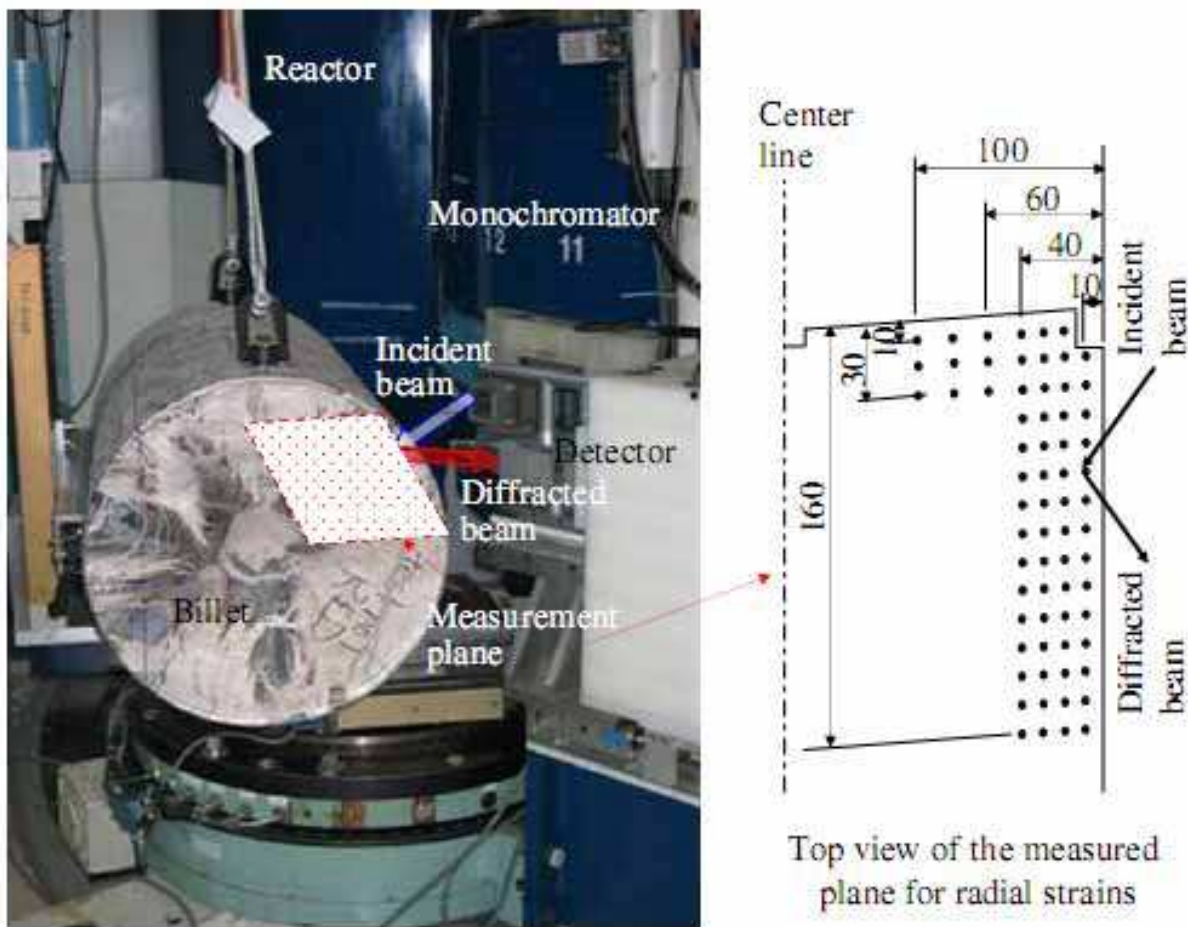

Fig. 2. Neutron diffraction apparatus and the schematic beam locations of radial strain measurement

Fig.3~5 display the strains components measured by neutron diffraction, based on the strain measurement results, the stress component can be calculated by using the following equation:

$$\sigma_i = \frac{E}{1+\nu} \left[\varepsilon_i + \frac{\nu}{1-2\nu} (\varepsilon_a + \varepsilon_r + \varepsilon_h) \right] \quad (1)$$

Where σ_i and ε_i are the stress and strain, respectively, in one of the three directions, E the Young's modulus and ν the poisson ration for the measured specimen. This information could be used to estimate the cracking tendency in the direct chill cast AZ31 billet.

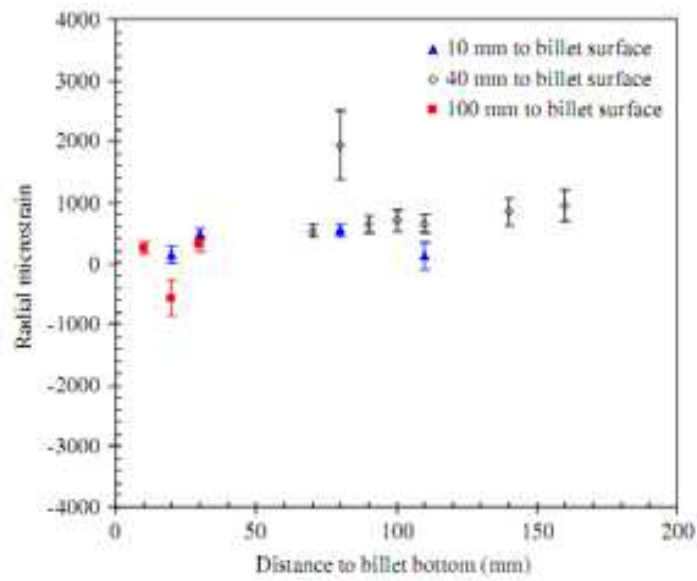

Fig. 3. Measured radial strain at different paths (10, 40 and 100 mm to the billet surface)

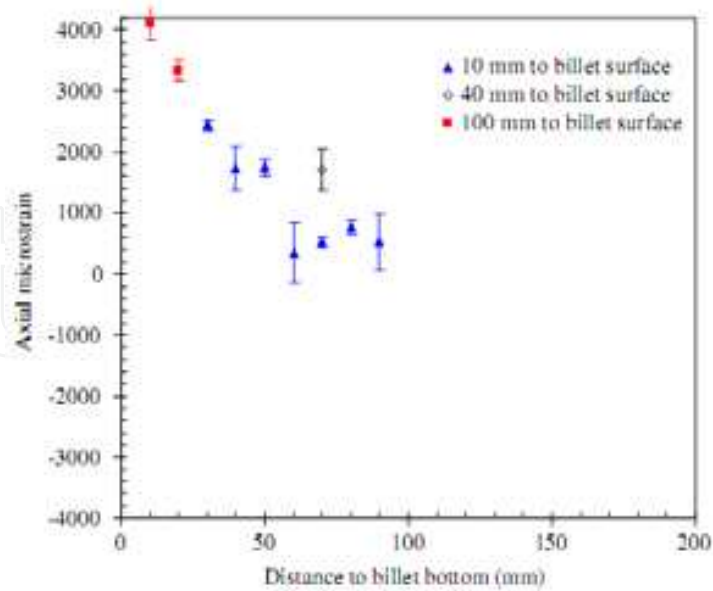

Fig. 4. Measured axial strain at different paths (10, 40 and 100 mm to the billet surface)

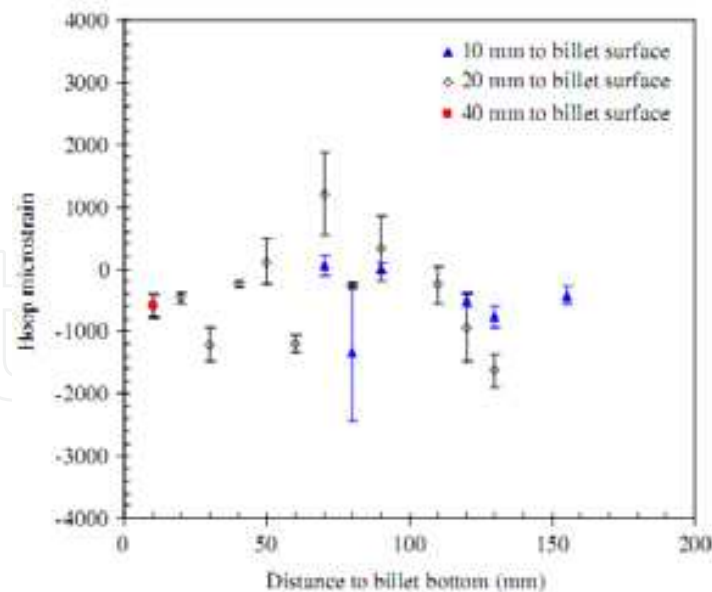

Fig. 5. Measured hoop strain at different paths (10, 20 and 40 mm to the billet surface)

2.2 Modeling the stress-strain behavior during DC casting of magnesium billets

Mathematical modeling of the DC casting process has been the focus of study from the middle of the twentieth century. However, since Adenis et al.^[3] reported their modeling work on DC casting of magnesium in 1962, very little other work has been done on this alloy system, and to date, no attempts to predict stresses, strains, or hot tearing during magnesium alloy DC casting have been reported. In contrast, a considerable body of work has been reported on modeling the DC casting process in aluminum alloys. The most recent of these include the majority of the relevant phenomena that are thought to affect heat transfer and stress/strain development: boiling water heat transfer during cooling, water incursion between the base of the ingot and the bottom block, and macroscopic ingot distortions (butt curl and lateral pull in). There have also been some attempts to integrate various hot tearing criteria, which incorporate mushy zone pressure drop and strain-rate effects, appears to be the most successful in qualitatively predicting the correct location of hot tearing in DC cast billets. Alternative approaches to predict hot tearing include a strain-based criterion ^[17] or a stress-based criterion ^[18]. While significant progress has been made, fully quantitative hot tearing predictions remain elusive, in part due to the stochastic nature of this defect.

H.Hao et al. ^[19] reported their work on modeling the stress-strain behavior and hot tearing during DC casting of AZ31. In this work, a coupled thermal-mechanical axisymmetric simulation of the DC casting process for magnesium AZ31 cylindrical billets has been developed using the commercial FE package ABAQUS. The model domain section of this geometry was included in the model. A schematic of the model domain is shown in Fig.6, for a billet with a length corresponding to 505 seconds of casting time. The domain consists of 3582 elements and 3833 nodes, each approximately 10 mm×10 mm in size. All three parts of the domain – billet, dummy block, and the center bolt – were modeled using four noded isoparametric coupled temperature/displacement elements. To simulate the casting process, a Lagrangian approach was used, whereby the thermal boundary conditions describing the primary and secondary cooling regions were moved up along the domain at

a rate consistent with the billet elements were incrementally added based on the mold filling rate and casting speed.

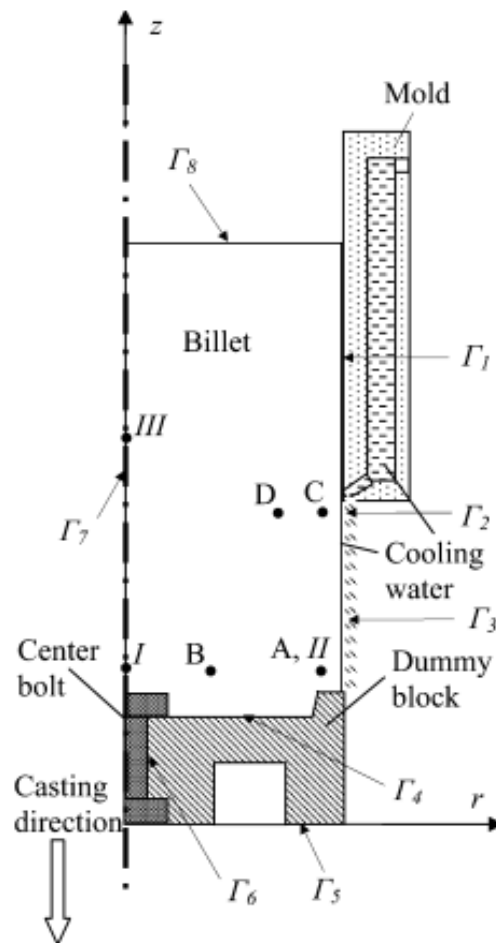

Fig. 6. Schematic of DC casting process used for magnesium billet casting, calculation domain, the relevant surfaces (Γ_1 through Γ_8) for application of boundary conditions, the thermocouple locations (A through D) during the plant trial, and the points (I through III) of interest for the stress-strain analysis.

The governing partial differential equation for the transient thermal analysis in cylindrical coordinates is

$$\frac{1}{r} \frac{\partial}{\partial r} \left(k(T) r \frac{\partial T}{\partial r} \right) + \frac{\partial}{\partial z} \left(k(T) r \frac{\partial T}{\partial z} \right) = \rho c_{\rho} \frac{\partial T}{\partial t} \quad (2)$$

Where \mathbf{r} and \mathbf{z} are the radial and axial directions in meters, respectively; k is the thermal conductivity in $\text{W m}^{-1} \text{K}^{-1}$; T is the temperature in Kelvin; ρ is the density in kg m^{-3} ; and c_{ρ} is the specific heat in $\text{J kg}^{-1} \text{K}^{-1}$. The latent heat released during solidification is incorporated into Eq.[2] by modifying the specific heat term for temperatures within the solidification interval according to $c_{\rho,e} = c_{\rho} + L \frac{df_s}{dT}$, where $c_{\rho,e}$ is the equivalent specific heat, L is the latent heat of fusion in J kg^{-1} , and $\frac{df_s}{dT}$ represents the rate of change of fraction solid with temperature. In the mechanical analysis, the stress and strain increments are derived based

on the nodal displacements along with the compatibility and constitutive equations. The resulting total strain vector, $\Delta\varepsilon^{tot}$, is given by

$$\Delta\varepsilon^{tot} = \Delta\varepsilon^{el} + \Delta\varepsilon^{th} + \Delta\varepsilon^{pl} \quad (3)$$

Where $\Delta\varepsilon^e$ is the elastic strain increment, $\Delta\varepsilon^{th}$ is the thermal strain increment, and $\Delta\varepsilon^{pl}$ is the plastic strain increment. Note that the constitutive equation is based on an elastic/rate-independent plastic material formulation.

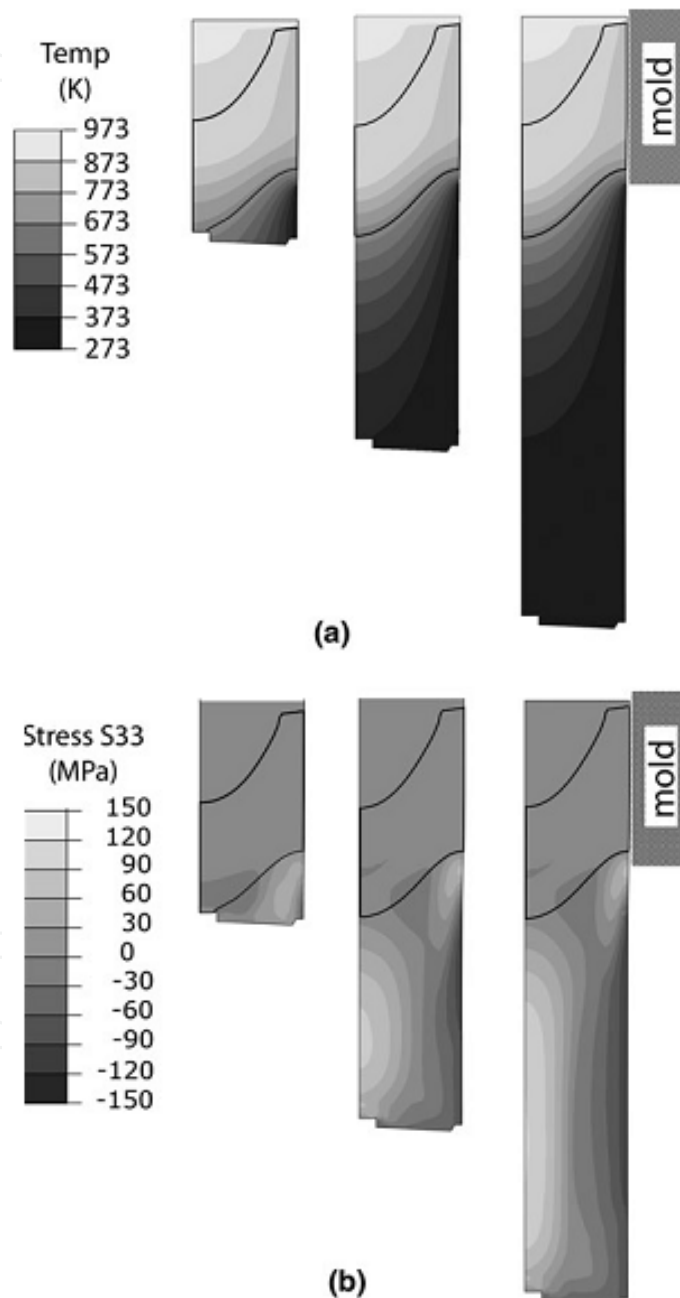

Fig. 7. Contour plots showing the evolution in (a) temperature and (b) hoop stress predicted by the model at 505, 1050, and 1490 s. The mushy zone is highlighted via a black contour line, while the location of the mold is given by a checkered rectangle.

Fig.7 shows contour plots of temperature and hoop stress in the cross section of the billet after 505, 1050, and 1490 seconds. The hoop stress is shown since, per Eq. $\dot{\epsilon}_{\perp}^{pl} = \dot{\epsilon}_r^{pl} \sin \gamma - \dot{\epsilon}_z^{pl} \cos \gamma + \dot{\epsilon}_{\theta}^{pl}$ (where γ is the angle between the thermal gradient and the radial axis θ is the hoop direction), it is considered to be the major driving force for crack initiation and hot tear propagation in billet casting. The mushy zone has been outlined in the figures at 505, 1050, and 1490 seconds using a black line. As can be seen from the thermal contours, cooling is dominated by the secondary water cooling, which strikes the ingot surface just below the mold. Since the mushy zone does not appear to be changing size or shape relative to the mold in the three thermal contours shown, it would appear that steady-state thermal conditions are reached before 505 seconds. At the ingot center, the pool depth is estimated to be 0.2 m by 505 seconds. As shown in the contours presented in Fig.7(b), the surface of the billet below the mold is in a state of tensile stress, due to the thermal contraction induced by the cooling water sprays. Moving down the ingot, as the thermal gradient moderates, the surface stress state becomes compressive while the center region is in tension to maintain internal equilibrium. The length of the surface region in compression and the length of the center region in tension, below the water impingement zone, increase with increasing cast length. The distribution of stresses arises, because the tensile stresses that are generated at the surface of the ingot near the point of secondary cooling water impingement exceed the yield point of the material resulting in the accumulation of tensile plastic strain. Once this material cools it is placed into compression and the interior material into tension. The maximum value of the hoop stress is ~ 150 MPa, well above the yield point of the as-cast structure. It can also be seen that the mushy zone remains in a low state of tensile stress throughout the casting process. While this stress value is low, it has exceeded the material's yield limit resulting in permanent deformation.

The thermomechanical simulation can be used to provide a detailed description of the evolution of stress and strains during the industrial casting of magnesium alloys.

3. Application of EPM on DC casting of magnesium alloys

Besides the conventional casting technology, this part introduces the application of EPM (Electromagnetic Processing of Materials) on the magnesium alloys. EMC is a technology developed by a combination of MHD and casting engineering. The casting method employs the effects of electromagnetic forces upon the liquid metal placed in the alternating electromagnetic field, which is induced by an inductor. The electromagnetic forces are produced by interaction of eddy currents induced in the metal with the magnetic field of the inductor. The main advantage of the EMC technology consists in the presence of stirring motions in the melt, which lead to a significant reduction of the grain size in the solidified product. Moreover, surface quality and subsurface quality are improved due to the absence of ingot mold. The surface finish of the ingot is usually smooth enough to be hot rolled without the scalping operation that is required following direct chill casting. Besides refining internal structures, electromagnetic stirring also has advantages of homogenized alloy elements, reducing porosity and segregation, and minimizing internal cracks. Because of these distinct merits of EMC technology, many scientists and engineers in different countries are engaged in this field.

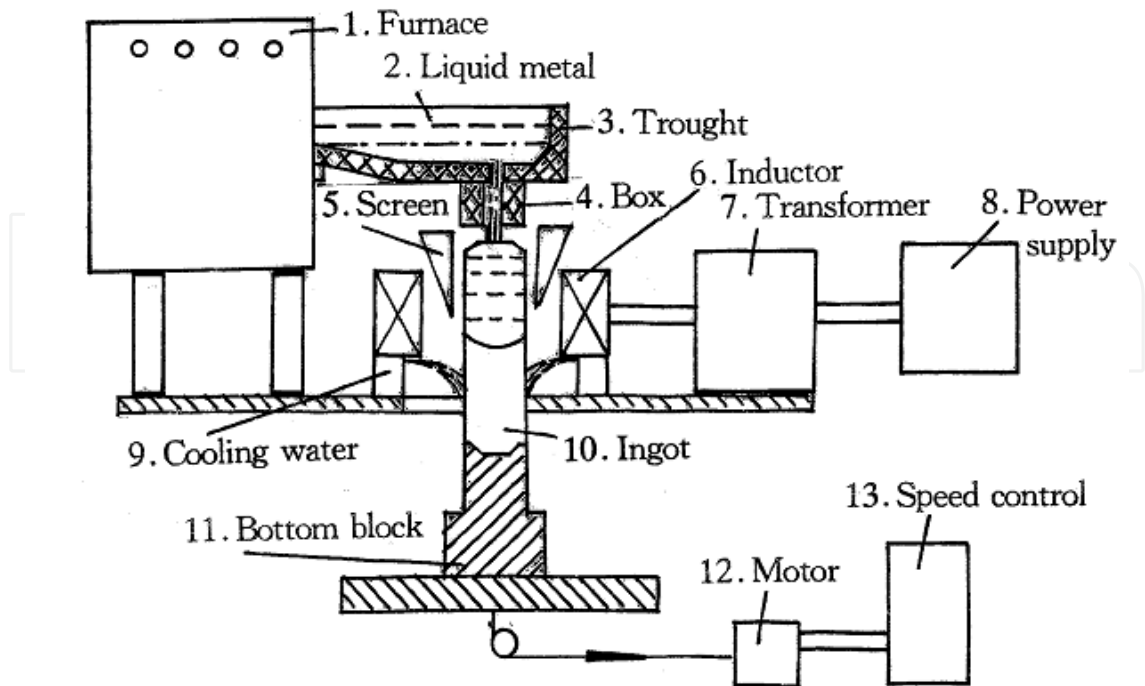

Fig. 8. Schematic diagram of EMC equipment

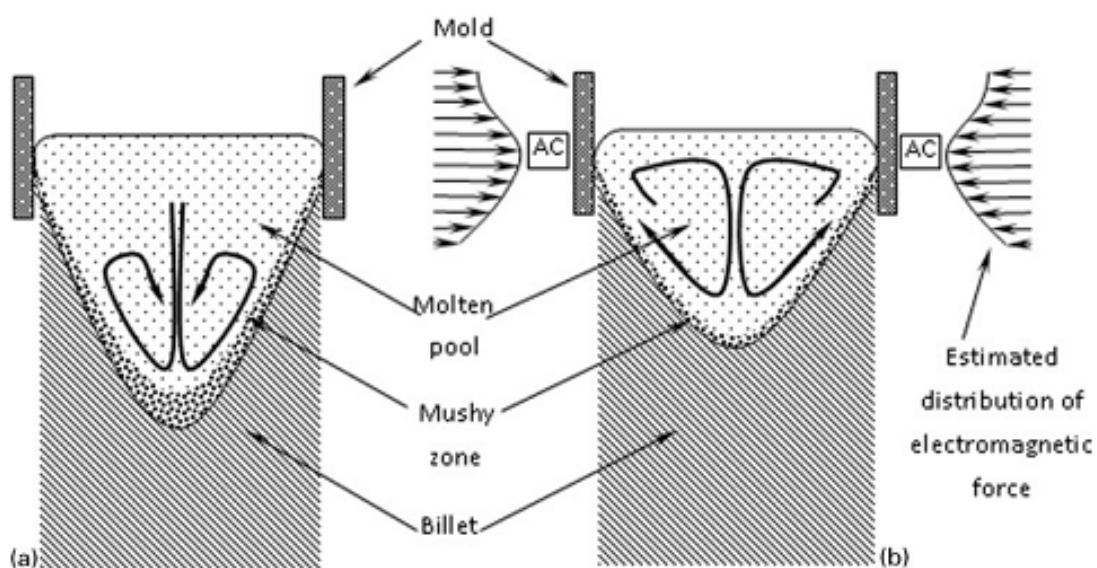
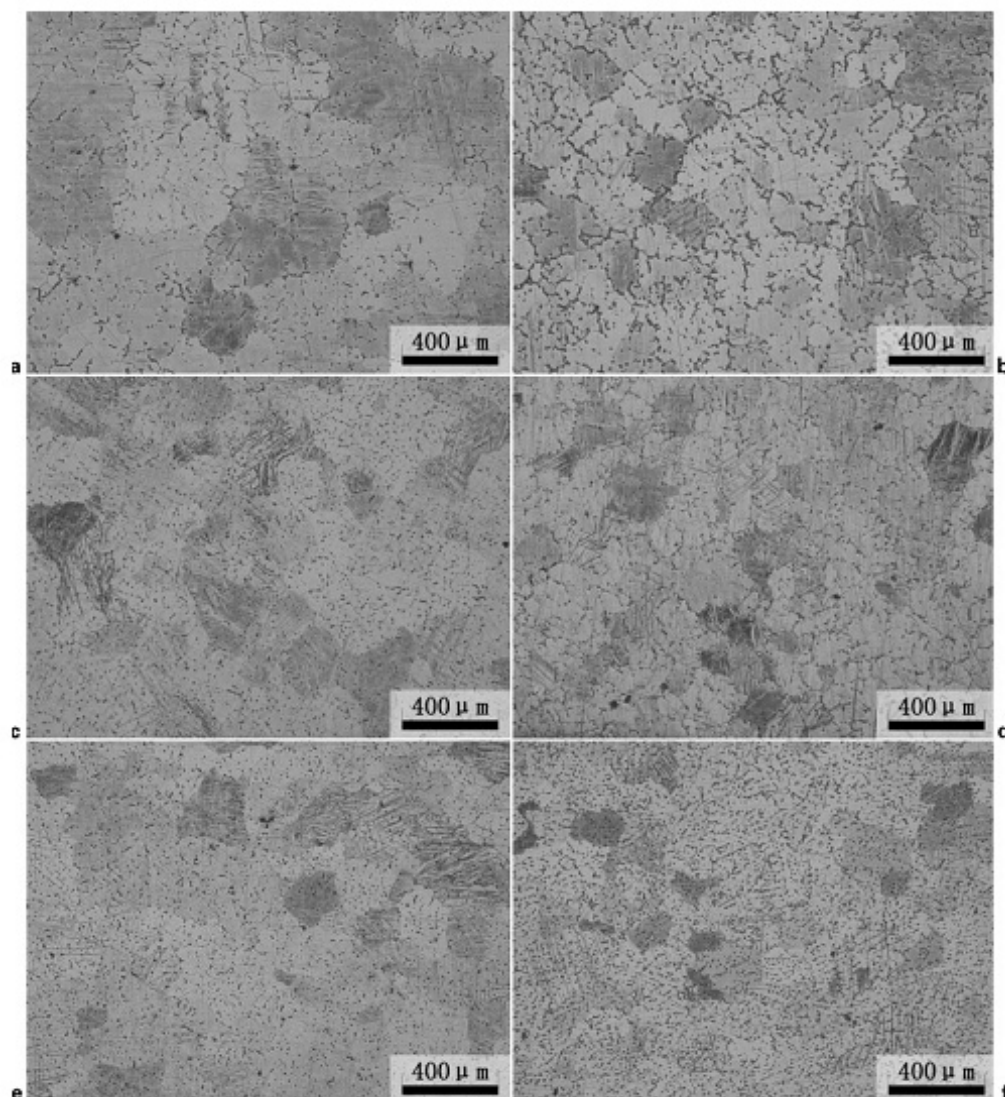

Fig. 9. Schematic diagram of a DC and b MFEMC

The continuous casting of aluminum is the foundation of the electromagnetic casting (EMC), which began from the direct chill casting invented by Aloca corporation and Vlw corporation in 1935^[20]. The principle of EMC was firstly described by Getselev and his co-workers in 1960^[21]. And then, they cast the first EMC ingot in laboratory in 1966. Thereafter, the industry-scale ingots with diameter from 200mm to 500mm were cast in 1969. Subsequently, this method was spread to the former Czechoslovakia and other Eastern

European countries. The principal advantage of the technology is that the metal is cast without contacting a physical mold depending on the electromagnetic forces, which excludes liquation build-ups and feather, and consequently, the surface finish of the ingot is usually smooth enough to be hot rolled without scalping operation. Because of the strong magnetic field, the structure and properties of the EMC ingot become much better. Since 1970's, occident has developed the technology in a big degree. The ingots of aluminum, copper, zinc, magnesium and their alloys were cast. At the same time, the new methods lying on different direction such as GE Levitation EMC and Horizontal EMC were implemented for casting ingots^[22].



a: border of DC; b: border of MFEMC; c: one-half radius of DC; d: one-half radius of MFEMC; e: centre of DC; f: center of MFEMC;

Fig. 10. Microstructures of AZ31 alloy billets cast in different processes

The basic apparatus of EMC consists of delivery system, casting control system, shaping and cooling system, melt furnace and power supply, as shown in Fig.8^[23]. The shaping system composed of an inductor, screen, cooling water box and bottom block is the main

component of this piece of equipment. A medium frequency alternating current is used to generate the alternating magnetic field in the molten magnesium. This magnetic field generates a heavy eddy current on the surface of the molten magnesium in opposite phase to the imposed current through the electromagnetic coil. These results in forces directed towards the center of the ingot. The electromagnetic force located within the upper liquid part of the ingot prevents the metal from touching the mold. A metal ring screen is necessary to control the magnetic field in the top of the melt, to keep the balance between the electromagnetic pressure and the hydrostatic pressure, and to achieve optimum horizontal flow and distribution of the liquid metal (Fig.9). Recently, with the development of superconducting magnet technology, a new branch of EPM, materials processing under a high magnetic field is dramatically highlighted. The magnetic intensity of the high magnetic field can reach 10^3 times stronger than that of the common magnetic field. The effects of magnetic force of high magnetic field on the paramagnetic and diamagnetic materials can't be ignored any more. Many interesting phenomena have been found, such as orient alignment of the structures, variation of solid-state phase transformation, etc.

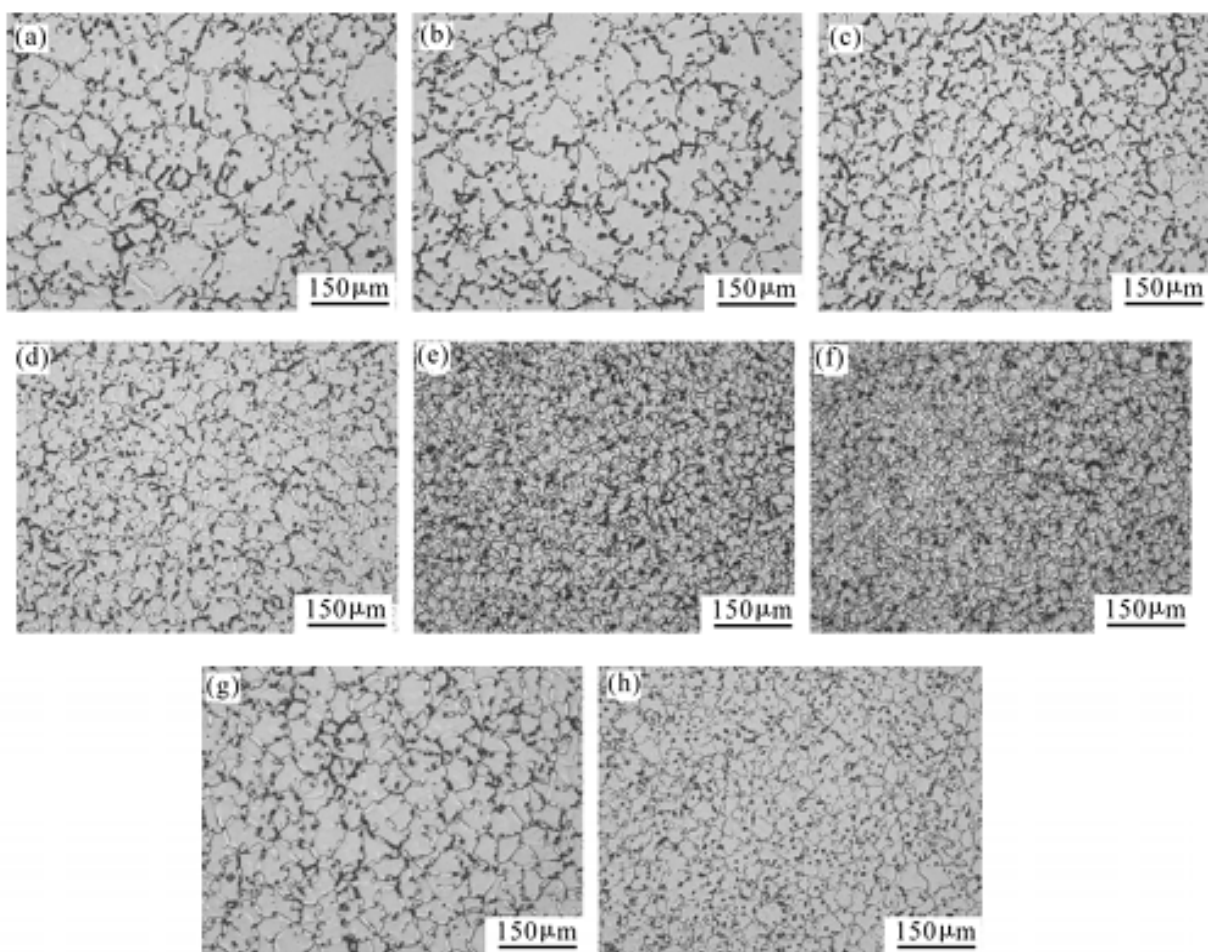

Fig. 11. Microstructure of ZK60 alloy billets cast under different electromagnetic powers: (a) DC casting edge; (b) DC casting center; (c) EMC-5KW edge; (d) EMC-5KW center; (e) EMC-10kW edge; (f) EMC-10kW center; (g) EMC-20kW edge; (h) EMC-20kW center

Billets of AZ31 magnesium alloy with and without intermediate frequency electromagnetic field were investigated by Pang et al. [24]. In his work, compared with microstructures and mechanical properties of the DC casting billet, the medium-frequency electromagnetic continuous casting (MFEMC) billets shows refined and even microstructures throughout the whole section of the billet and improved mechanical properties, the microstructures of AZ31 billets cast in different processes are shown in Fig.10. Ren et al.[25] have studied the effects of middle frequency electromagnetic field on the precipitations of ZK60 magnesium alloys, the results show that the microstructure are refined and distribution uniformity of precipitations is observed after applying the middle frequency electromagnetic field(Fig.11). The refined microstructure is in connection with increased nuclei which are likely to be as a result of electromagnetic undercooling which decreases the free energy barrier of nucleation and increases the nucleation tendency by an induced undercooling ΔT and forced convection. The movements between grain sizes of different locations in the billet are a result of particles' forced movements with particles in the inner area moving outward and particles in the border area moving inward.

4. Effects of ultrasonic field on Mg-based alloys

Magnesium alloys are getting increased attention for their low density, high specific strength, high specific rigidity and good damping capacity. However, the use of magnesium alloys has been restricted by their limited mechanical properties. Several previous investigations proposed that high intensity ultrasonic treatment was one of the effective ways to improve the solidification structure and the mechanical properties of metals. Ultrasonic vibration of aluminum alloys had been studied extensively, and it can effectively refine the grain size. Investigations carried out between 1960 and 1990[26], mainly in the former Soviet Union countries, clearly demonstrated its grain-refining effects on magnesium alloys and significantly improved mechanical properties. The introduction of powerful ultrasonic oscillations into the melt can be quite simply adapted to the commercial technologies of continuous casting (vertical, horizontal DC casting, strip casting, etc.) and shape casting (precise, die casting, liquid forging, etc.) Ultrasonic degassing, an environmentally clean and relative inexpensive technique, should be paid more attention on speeding up the industrial application and revealing the mechanism the effects on the solidification process.

Fig.12 is the illustration of a direct ultrasonic treating process. The ultrasonic equipment is comprised of a 20 kHz ultrasonic power, an ultrasonic transducer made of piezoelectric ceramics, an ultrasonic amplitude transformer and an ultrasonic probe. The ultrasonic amplitude transformer and probe are made of stainless steel. The grain refinement of ultrasonic treatment on the microstructure of alloys is based on the physical phenomena arising out of high-intensity ultrasound propagation through the liquid. Considerable work has been carried out to determine the grain refinement mechanisms by ultrasonic treatment and two underlying mechanisms have been proposed for ultrasonic grain refinement based on cavitation: (i) cavitation-induced (shock waves) dendrite-fragmentation and (ii) cavitation-enhanced heterogeneous nucleation [27-30]. Cavitation-induced dendrite fragmentation hypothesis assumes that the shock waves generated from the collapse of bubbles lead to fragmentation of dendrites, which are redistributed through acoustic streaming and increasing the number of crystals [30-31]. Cavitation-enhanced heterogeneous

nucleation interpreted further in terms of two different mechanisms. The first is the pressure pulse-melting point (T_m) mechanism^[28-29], where the pressure pulse induced by the collapse of a bubble alters T_m according to the Clapeyron equation $\Delta T_m = T \Delta P \Delta V / \Delta H$.

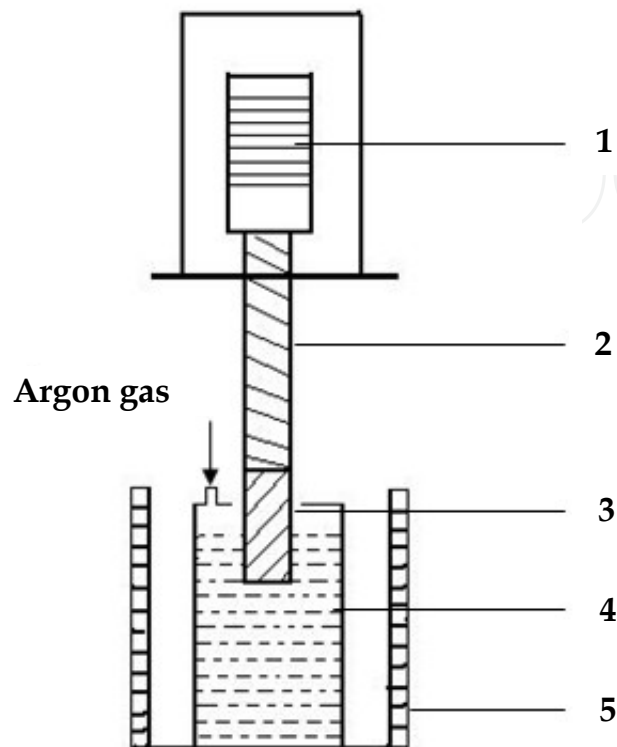

Fig. 12. Schematic diagram of the experiment apparatus 1- Ultrasonic transducer; 2- Amplitude transformer; 3-Ultrasonic probe; 4- Stainless steel mould; 5- Heat preserving furnace.

An increase in T_m is equivalent to increasing the undercooling and so an enhanced nucleation event is expected. The second mechanism is cavitation-induced wetting^[28], where the defects (cavities or cracks) on the substrate surfaces with the pressure pulse can act as effective nucleation sites, leading to enhanced nucleation^[28].

Mg-Li series alloy are called ultra-light magnesium based alloys because they are the lightest metal structural material. They have high specific strength and stiffness, good damping capacity, and electromagnetic shielding properties. It will reduce the energy consumption if Mg-Li series alloys are successfully widespread applied. But the strength of Mg-Li alloys at room temperature especially at high temperature is low, which limits their applications. In order to obtain the uniform microstructure and high strength of Mg-Li alloys, Yao et al.^[32] introduced the ultrasonic vibration into the solidification process of the Mg-8Li-3Al alloy. With the effects of Ultrasonic treatment, the morphology of α phase was modified from coarse rosette-like structure to fine globular one (Fig.13), and the tensile strength and elongation were improved by 9.5% and 45.7%, respectively. With the purpose of investigating the mechanism of grain refinement under ultrasonic vibration, the effects of ultrasonic vibration power on fluid field is described by particle image velocimetry (PIV). Fig.14 shows the ultrasonic filed can transmit in the fluid and form circulation flow to uniform the microstructure.

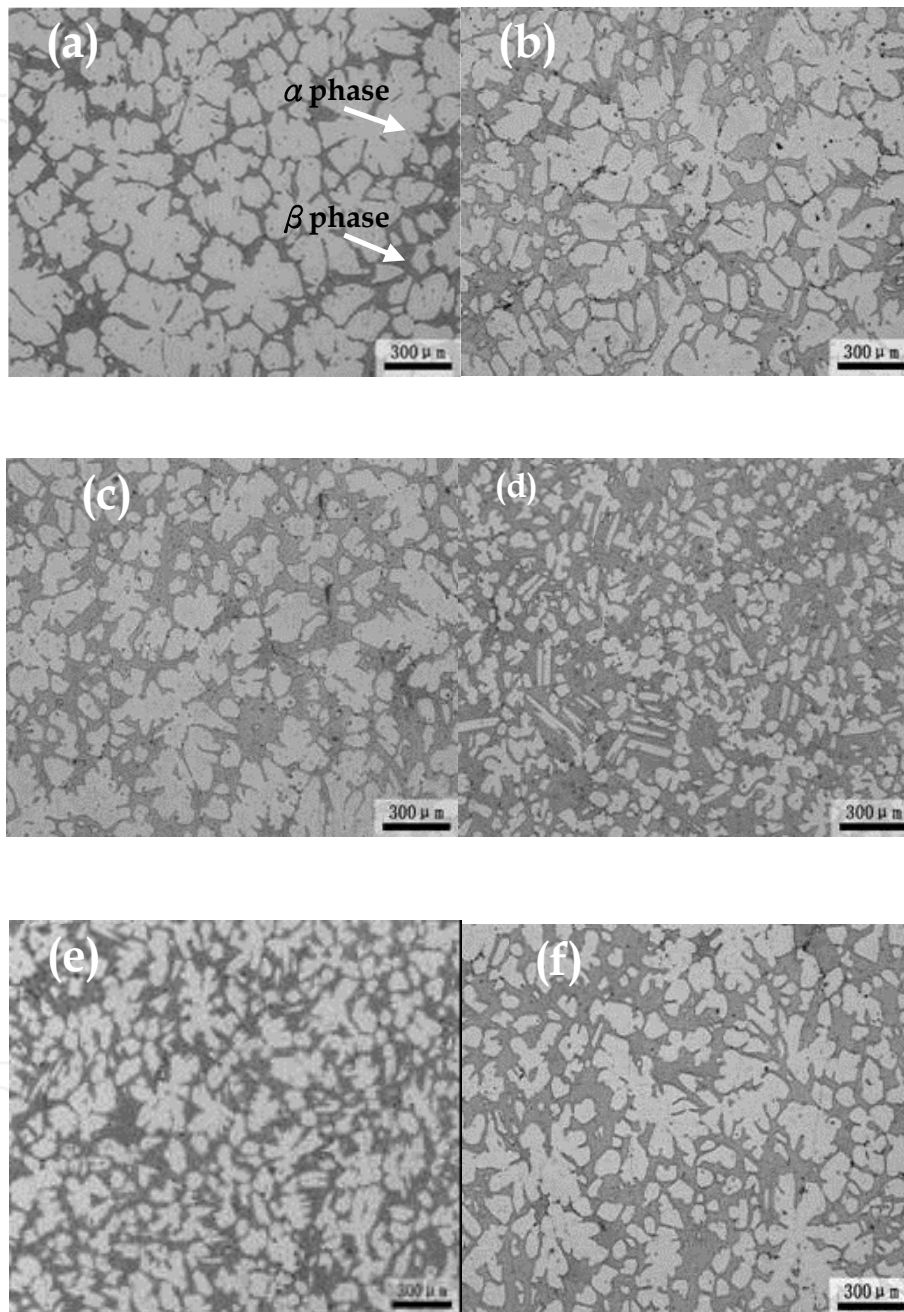

Fig. 13. Microstructures of specimens obtained with different ultrasonic vibration powers:(a) 0W (b) 50W (c) 110W (d) 170W (e) 210W (f) 260W.

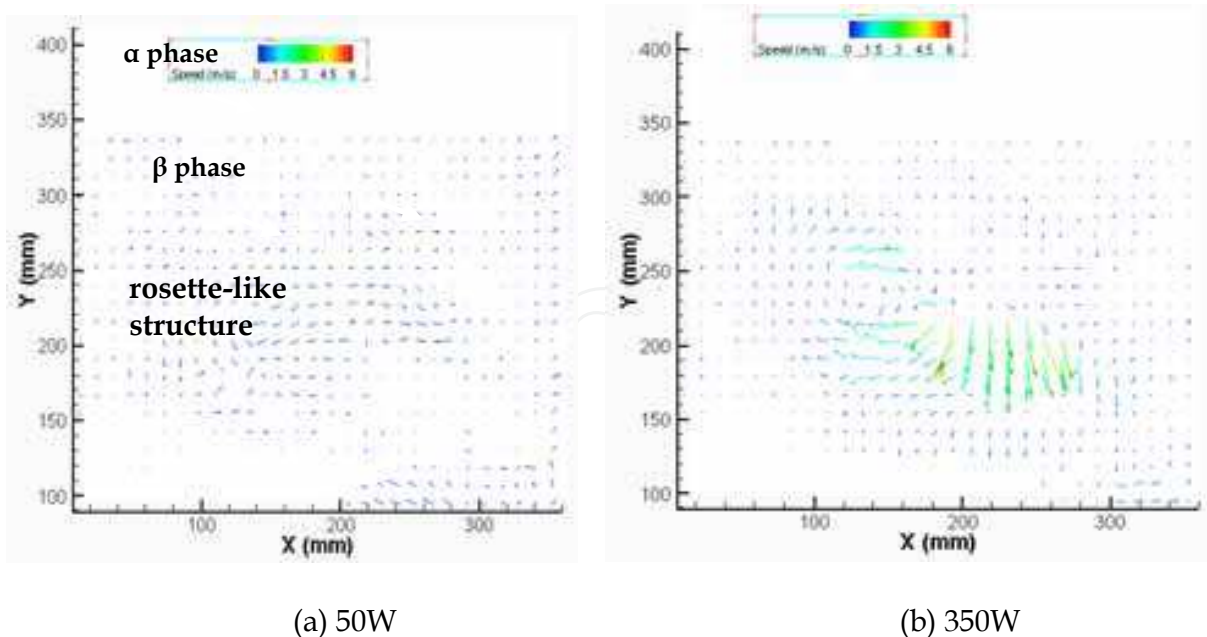

Fig. 14. Effects of ultrasonic vibration power on fluid field by PIV physical simulation

5. Grain refinement of magnesium alloys

Magnesium alloys have extensive applications due to their comprehensive properties, such as low density, high specific strength, improved damping property and their recyclability. However, magnesium has bad plastic processing ability because of their HCP structure^[33]. For magnesium alloys grain refinement is important as a fine grain size generally lead to improved mechanical properties and a more uniform distribution of secondary phases and solute elements on a fine scale which results in better machinability, good source finish, and excellent resistance to hot tearing and superior extrudability.

In the last few decades, the grain refinement of Magnesium alloys has been a particularly active topic and deserves more and more attention. A variety of methods have been developed to refine the magnesium alloys, such as rapid quenching, particle incubation, adding solute elements, imposing external fields and mechanical stirring. Among these methods, adding grain refiner (elements, master alloy) is known to be more effective for reducing the grain size of Mg-based alloys and have great importance on the industrial applications. Depending on whether they are alloyed with aluminum, magnesium alloys can be generally classified into two broad groups: aluminum free and aluminum bearing. Magnesium alloys containing zirconium or grain refined by zirconium such as ZE41, ZK60, WE43 and ML10. These are an important high value added class of alloys are based on the exceptional grain refining ability of Zirconium when added to aluminum free magnesium alloys. Because aluminum and zirconium form stable intermetallic phases, which are ineffective as nucleants for magnesium grains, the exceptional grain refining ability of zirconium does not occur in the aluminum bearing magnesium alloys.

Due to the importance of grain refinement to a broad range of aluminum and magnesium alloys, considerable work has been carried out for over half a century to determine the mechanisms by which grain refinement occurs. It is now generally accepted that both the potency of the nucleant particles (defined here as the undercooling required for nucleation,

ΔT_n) and the segregating power of the solute (defined as the growth restriction factor, Q) are critical in determining the final grain size. Easton and StJohn^[34-35] developed a model that takes into account both ΔT_n and Q , and good agreement was found between this model and experimental results and proposed a semiempirical equation below for grain formation under small undercoolings:

$$d = \frac{1}{\sqrt[3]{fN_v}} + \frac{b' \cdot \Delta T_n}{Q} \quad (4)$$

Where N_v is the number of relatively potent nucleant particles present in the melt and f is the fraction of those particles that actually nucleate a grain.

Theoretically, Q was originally derived to be inversely proportional to the growth rate of the primary phase. More recently, it has been defined as the initial rate of development of constitutional undercooling with respect to fraction solid and can be estimated using the sum (GRF) of $mc_0(k - 1)$ of the individual elements present in most wrought alloy systems, where m is the slope of the liquids, c_0 is the concentration of the element, and k is the partition coefficient. The higher GRF and solute element content is, the more obvious the effect of refining the solute elements in the alloy.

According to the equation (4), the addition of potent nucleant particles can lead to grain refinement of magnesium alloys. There is a necessary condition for the nucleant particles to act as heterogeneous nuclei, that is, the disregistry between low indexes planes of adjoining phases must be less than 15%. According to the disregistry model of two-dimensional lattices proposed by Bramfitt^[36], the formula is :

$$\delta_{(hkl)_s}^{(hkl)_n} = \sum_{i=1}^3 \{ |d[uvw]_s^i \cos \theta - d[uvw]_n^i| / d[uvw]_n^i \} / 3 \times 100\% \quad (5)$$

Where $(hkl)_s$ and $(hkl)_n$ are the low index planes of the matrix and nucleus, respectively, $[uvw]_s$ and $[uvw]_n$ are the low index orientations in $(hkl)_s$ and $(hkl)_n$, respectively, $d[uvw]_s$ and $d[uvw]_n$ are atomic spacing distances along $[uvw]$, and θ is the angle between $[uvw]_s$ and $[uvw]_n$. Some compounds, such as AlN, SiC, FeAl and AlMn, have also been reported to be potential heterogeneous nucleation agents for Mg alloys, and AlN appears to be the most promising of all these compounds, because AlN has a simple HCP structure with lattice parameters of $a=0.3111\text{nm}$ and $c=0.4979\text{nm}$, which are very close to the lattice parameters of the Mg matrix ($a=0.3209\text{nm}$, $c=0.5211\text{nm}$). The disregistry between AlN and a-Mg in the low index planes (0001) is 3.05%, respectively. Fig.15^[37] show the microstructure of AZ31 alloys with AlN additions.

It is well known that Al-5Ti-B master alloy is an effective grain refiner in aluminum alloys. From the literature, GRF values of Ti, is far greater than the other alloying elements (e.g. Zr, Sr, Ca, etc.) values, and according to the equations(4), the crystal lattice mismatch between (0001) of TiB₂ and (0001) of Mg is 5.6% (<9%) , the crystal face (0001) of TiB₂ can be seen the heterogeneity nucleation basis of Mg phase .More and more researchers pay more attention on the effects of Al-Ti-B additions on the grain size of Mg-based alloys. Qi et al. ^[38] reports optimum average grain size and mechanical properties of AZ31 magnesium alloy with Al-5Ti-1B master alloy is obtained when the addition of Al-5Ti-1B master alloy is at 0.5wt% , shown in the Fig.16.

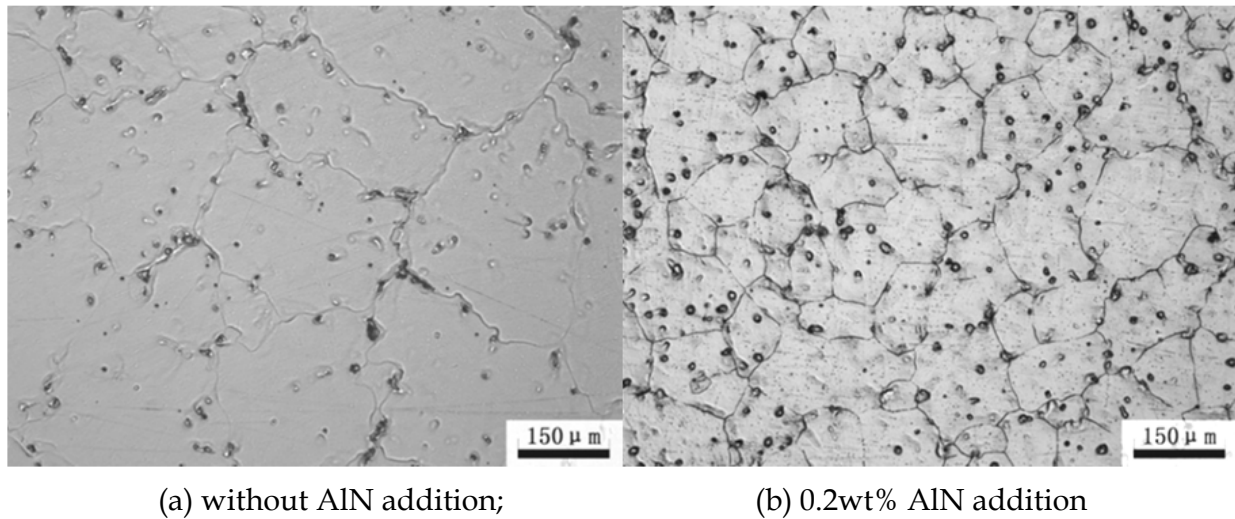

Fig. 15. Microstructures of AZ31 alloys

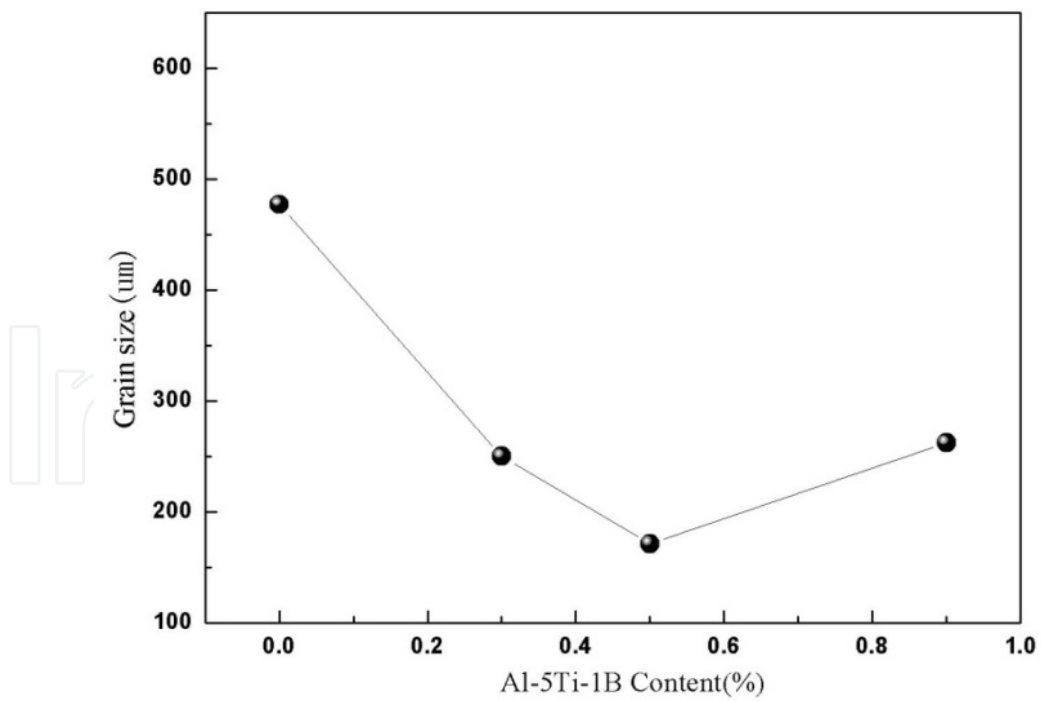

Fig. 16. The relationship between the content of Al-5Ti-1B master alloys and grain size of AZ31 alloy

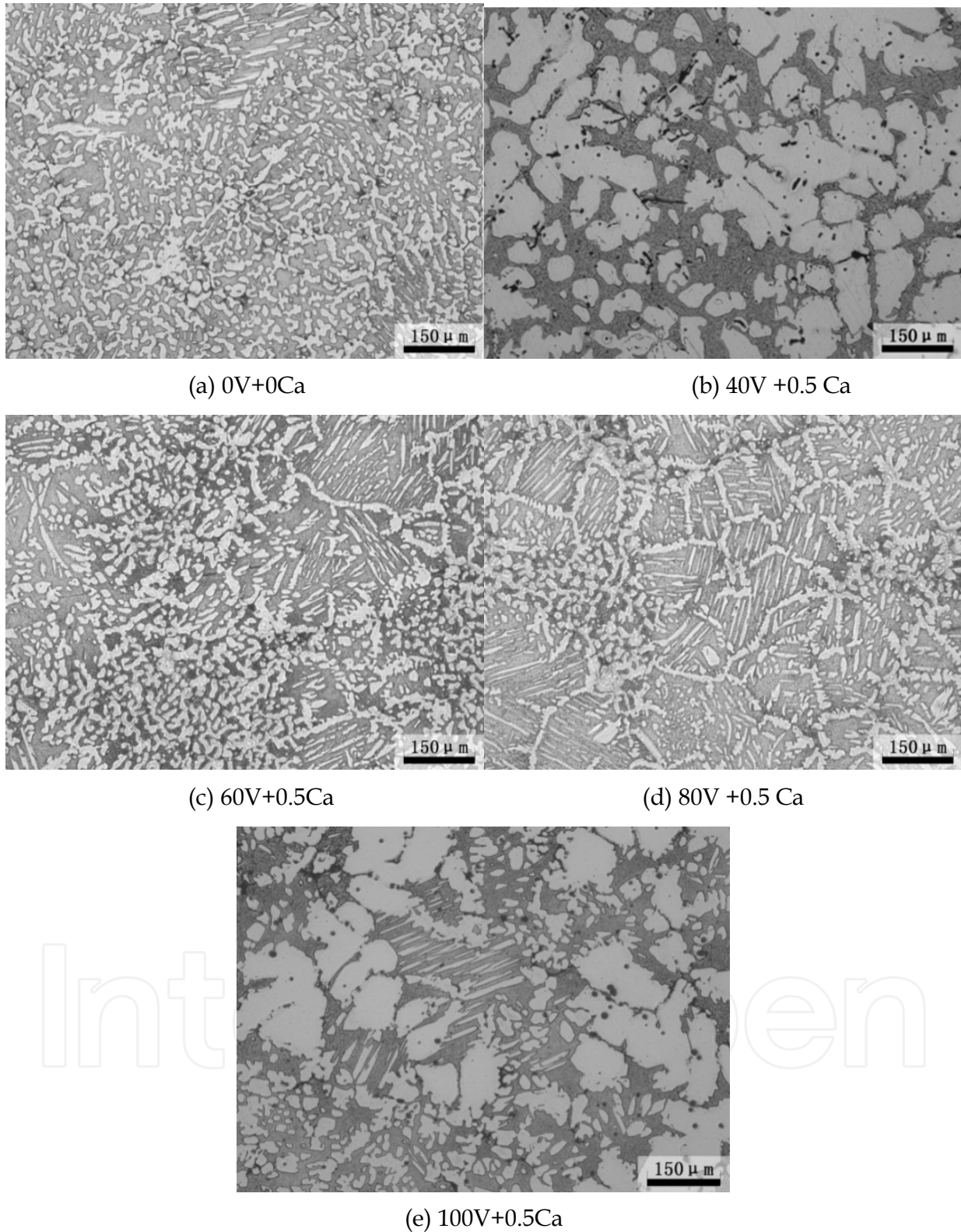

Fig. 17. Effects of Ca and electromagnetic stirring on the microstructure of Mg-8Li-3Al alloys

In recent years, the research about compound effects of alloying and external fields on grain refinement of magnesium attracts more and more attention. It is well known that the most important characteristic of magnetic field is its capacity to inject thermal and mechanical

energy into materials without contact between the materials and the power source, which can produce driving, stirring, purifying or transmitting, leading to reduce the grain size and improve the mechanical properties. Hao et al.^[39] have studied the couple effects of Ca and electromagnetic field on microstructure and mechanical properties of Mg-Li-Al alloys. In his work, when the electromagnetic stirring voltage is 80V, 0.5% Ca addition could make the microstructure fine and uniform (Fig.17) and the tensile strength was increased to 203.8Mpa.

6. The future of cast technology and quality improvement of magnesium alloys

Magnesium alloys have been called “the 21th century’s engineering materials” for their high specific strength, high stiffness ratio, good machinability, good thermal conductivity and especially for their damping capability. However, the low mechanical properties and poor chemical properties, such as corrosion and creep resistance have restricted their extensive application. Despite these problems, the potential benefit of magnesium alloys has lead to a recent increase in demand for cast and wrought magnesium products. With this increase, the casting process is receiving significantly more attention from the standpoint of process optimization. Typical defects that occur during DC casting include both hot tearing as well as cold cracking that lead to downstream defects during subsequent processing operations, and are major sources which restrict the productivity of the process and its viability of alloys and ingot size. Modeling the stress-strain behavior and hot tearing of an AZ31 billet is able to quantitatively describe the evolution of temperature in the billet and quantitatively predict the development of residual stresses/strains. The application of EPM on the magnesium alloys can refine grain size and improve the material performance and this technology has become a helpful means to obtain high quality metal products. Ultrasonic treatment is one of the effective ways to improve the solidification structure of magnesium alloy and can improve the corrosion resistance and mechanical properties. A fine grain size generally leads to improved mechanical properties and structural uniformity of magnesium alloy, and more attention should be paid for the mechanism of grain refinement of magnesium alloys.

7. Acknowledgements

Financial support from the Program of New Century Excellent Talents of the Ministry of Education of China (NCET-08-0080), the National High Technology Research and Development Program (“863”Program) of China (2009AA03Z525), the Science and Technology Fund of Dalian City (2009J21DW003), and the Fundamental Research Funds for the Central Universities (DUT11ZD115) are gratefully acknowledged.

8. References

- [1] P.T. McGlade, 6th Aus. Asian Pacific Conf. On aluminum cast house technology, sydney, Australia, 1999, P.R.Whiteley and J.F. Grandfield;
- [2] D.C. Weckman, P. Niessen. A numerical simulation of the D.C. continuous casting process including nucleate boiling heat transfer[J]. Metallurgical and materials transactions B. 1982,13:593-602;

- [3] D. Adenis, K. Coats, D.RAGONE. An analysis of direct-casting process by numerical methods[J]. Journal of the institute fo metals. 1963,91:395-403;
- [4] S.G. Hibbins. In light metals 1988 metaux legers, M.Sahoo and C.C. FRADET, eds., TMS-CIM, Calgary, AB, Canada, 1988:265-280;
- [5] H. Fossheim, E.E Madsen. Light metals, 1979, Newe Orleans, La, 1979, W.S. Peterson, ed. TMS-AIME, Warrendale, PA,1979:695-720;
- [6] H.G. Fjaer, A. Mo. Metall. Alspen-A mathematical- model for thermal-stresses in direct chill casting of aluminum billets. Metallurgical transactions B. 1990, 21: 1049-1061;
- [7] Y. Watanabe, N. Hayashi. Light metals 1996, Anaheim, CA, 1996, W.Hale,ed., TMS, Warrendale, PA:979-984;
- [8] J. Sengupta, S.L. Cockcroft, D. Maijer, M. Wells, A. Larouche. J. Light Met., 2002,2:137-148;
- [9] J. Senqupta, S. Cockcroft, D. Maijer, M. Wells, A. Larouche. On the development of a three-dimensional transient thermal model to predict ingot cooling behavior during the start-up phase of the direct chill-casting process for an AA5182 aluminum alloy ingot[J]. Metallurgical and materials transactions B. 2004,35B:523-540;
- [10] J.M. Drezet, M.Rappaz. Light metals 2001, New Orleans, La,2001, J.L. Anjier, ed., TMS. Warrendale, PA,2001:887-894;
- [11] M. Rappaz, J.M. Drezet, M. Gremaud. A new hot-tearing criterion[J]. Metallurgical and materials transactions A. 1999, 30A: 449- 455;
- [12] A. Stacey, H.J. MacGillivray, G.A. Webster, P.J. Webster, K.R.A. Ziebeck. Measurement of residual stresses by neutro diffraction[J]. Journal of strain Analysis, 1985,20:93-100;
- [13] P.J. Webster, X.D. Wang, W.P. Kang, G. Mills. Experimental verification of residual stress models using neutron strain scanning[C]. Campbell J,editor. Modelling of casting, welding and advanced solidification process VII. London, UK: The minerals, Metals & Materials Society;1995:311-318;
- [14] M.J. Schmank, A.D. Krawitz. Measurement of a stress gradient through the bulk of an aluminum alloy using neutrons[J]. Metallurgical Transactions A. 1982, 13:1069-1076;
- [15] J. Smith, M.N. Bassim, C.D. Liu, T.M. Holder. Measurement of crack tip strains using neutron diffraction[J]. Engineering Fracture mechanics. 1995,52:843-851;
- [16] H. Hao, D. Maijer, R. Rogge. Investigation of residual strains by neutron diffraction in an AZ31 direct chill cast billet[J]. NDT&E International. 2009,42:704-712;
- [17] M.M. Hamdi, A. Mo, H.G. Fjaer. Metall. Tearsim: A two-phase model addressing hot tearing formation during aluminum direct chill casting[J]. Metallurgical and materials transactions A. 2006,37A:3069-3083;
- [18] D.J. Lahaie, M. Bouchard. Metall. Physical modeling of the deformation mechanisms of semisolid bodies and a mechanical criterion for hot tearing[J]. Metallurgical and materials transactions B. 2001,32:697-705;

- [19] H. Hao, D.M. Maijer, M.A. Wells, A. Phillion, S.L. Cockcroft. Modeling the stress-strain behavior and hot tearing during direct chill casting of an AZ31 magnesium billet. *Metallurgical and materials transactions A*, 2010,41A:2067-2077.
- [20] M. Yoshida. Electromagnetic casting update to date and future[J]. *ISIJ*, 1987,73:403-410;
- [21] Z.N. Getselev. Electromagnetic ingot mold continuous casting[J]. *Journal of metals*. 1971, 23:38;
- [22] S. Asai, T. Kozuka, I. Muchi. Process development and stability analysis of horizontal electromagnetic casting method[J]. *Iron and Steel*. 1986,16:68-74;
- [23] Z.Q. Cao, F. J, X.G Zhang, H. Hao, J.Z. J. Microstructures and mechanical characteristics of electromagnetic casting and direct-chill casting 2024 aluminum alloys[J]. *Materials science and engineering*. 2002,A327:133-137;
- [24] L. Pang, X.G. Zhang, Z. Ren, L. Sui, T. Zhang, H. Hao. Effects of medium-frequency electromagnetic field on solidification process of semi-continuous casting AZ31 magnesium alloy[J]. *Materials research innovations*. 2009,13:107-111;
- [25] Z. Ren, X.G Zhang, H. Hao, L. Sui, Y.T. Ma, J.Z Jin. Effect of middle-frequency electromagnetic field on the semi-continuous casting for ZK60 billets[J]. *Journal of wuhan university of technology*. 2010,25:449-453.
- [26] O.V. Abramov. *Ultrasonic treatment of light alloy melts*[M]. CRC Press, Boca Raton, FL,1994:289-329
- [27] A. Ramirez, M. Qian, B. Davis, T. Wilks, D.H. Stjohn. Potency of high-intensity ultrasonic treatment for grain refinement of magnesium alloys[J]. *Scripta Materialia*. 2008,59:19-22;
- [28] G.I. Eskin. *Ultrasonic treatment of light alloy melts*, Gordon& Breach, Amsterdam, 1998:1-25,135-240;
- [29] J.D. Cutnell, K.W. Johnson. *J.Appl.Phys*.1966,37:254-257;
- [30] M.C. Flemings, *Solidification Processing* , McGraw-Hill, New York, 1974:300;
- [31] M Q, A. Ramirez, A. Das. Ultrasonic refinement of magnesium by cavitation: Clarifying the role of wall crystals[J]. *Journal of crystal growth*. 2009,311:3708-3715;
- [32] L. Yao. Research on microalloying and solidification control with external field of Mg-Li series alloys[D].Dalin, Dalian university of technology. 2010.(In chinese)
- [33] B.L. Mordike, T. Ebert. Magnesium properties-applications-potential[J]. *Materials science and engineering*. 2001,A302:37-45;
- [34] M.A. Easton, D.H. Stjohn. A model of grain refinement incorporating alloy constitution and potency of heterogeneous nucleant particles[J]. *Acta mater*. 2001,49:1867-1878;
- [35] M. Easton, D. Stjohn. An analysis of the relationship between grain size, solute content, and the potency and number density of nucleant particles[J]. *Metallurgical and materials transactions A*. 2005,36A:1911-1920;
- [36] B.L. Bramfitt. The effect of carbide and nitride additions on the heterogeneous nucleation behavior of liquid iron[J]. *Metallurgical and materials transaction B*. 1970,1:1987-1995;

- [37] S.W. Gu, H. Hao, C.F. Fang, S.H. Ji, X.G. Zhang. Effects of AlN particles and electromagnetic stirring on as-cast structure of AZ31 alloys[J]. Materials science forum. 2011, 675-677:771-774;
- [38] G.H. Qi, C.F. Fang, H. Hao, X.G. Zhang. Effects of Al-5Ti-1B master alloy on microstructure and properties of AZ31 magnesium alloy[J]. Special casting and nonferrous alloys. 2010, 30:266-269; (In Chinese)
- [39] H. Hao, L. Yao, S.W. Gu, L.J. Ma, X.G. Zhang. Effects of Ca and electromagnetic stirring on microstructures and mechanical properties of Mg-Li-Al alloys[J]. Transactions of nonferrous metals society of china. 2010, 20:388-392; (In Chinese)

IntechOpen

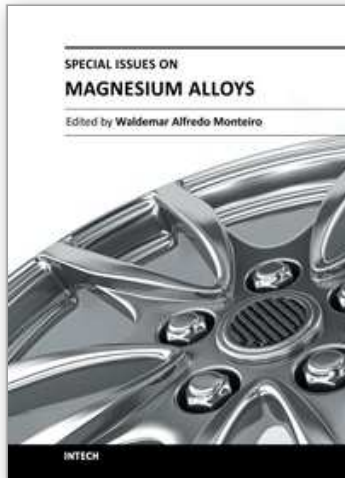

Special Issues on Magnesium Alloys

Edited by Dr. Waldemar Monteiro

ISBN 978-953-307-391-0

Hard cover, 128 pages

Publisher InTech

Published online 12, September, 2011

Published in print edition September, 2011

Magnesium is the lightest of all the metals and the sixth most abundant on Earth. Magnesium is ductile and the most machinable of all the metals. Magnesium alloy developments have traditionally been driven by requirements for lightweight materials to operate under increasingly demanding conditions (magnesium alloy castings, wrought products, powder metallurgy components, office equipment, nuclear applications, flares, sacrificial anodes for the protection of other metals, flash photography and tools). The biggest potential market for magnesium alloys is in the automotive industry. In recent years new magnesium alloys have demonstrated a superior corrosion resistance for aerospace and specialty applications. Considering the information above, special issues on magnesium alloys are exposed in this book: casting technology; surface modification of some special Mg alloys; protective carbon coatings on magnesium alloys; fatigue cracking behaviors of cast magnesium alloys and also, magnesium alloys biocompatibility as degradable implant materials.

How to reference

In order to correctly reference this scholarly work, feel free to copy and paste the following:

By Hai Hao (2011). Casting Technology and Quality Improvement of Magnesium Alloys, Special Issues on Magnesium Alloys, Dr. Waldemar Monteiro (Ed.), ISBN: 978-953-307-391-0, InTech, Available from: <http://www.intechopen.com/books/special-issues-on-magnesium-alloys/casting-technology-and-quality-improvement-of-magnesium-alloys>

INTECH
open science | open minds

InTech Europe

University Campus STeP Ri
Slavka Krautzeka 83/A
51000 Rijeka, Croatia
Phone: +385 (51) 770 447
Fax: +385 (51) 686 166
www.intechopen.com

InTech China

Unit 405, Office Block, Hotel Equatorial Shanghai
No.65, Yan An Road (West), Shanghai, 200040, China
中国上海市延安西路65号上海国际贵都大饭店办公楼405单元
Phone: +86-21-62489820
Fax: +86-21-62489821

© 2011 The Author(s). Licensee IntechOpen. This chapter is distributed under the terms of the [Creative Commons Attribution-NonCommercial-ShareAlike-3.0 License](#), which permits use, distribution and reproduction for non-commercial purposes, provided the original is properly cited and derivative works building on this content are distributed under the same license.

IntechOpen

IntechOpen