

We are IntechOpen, the world's leading publisher of Open Access books Built by scientists, for scientists

4,800

Open access books available

122,000

International authors and editors

135M

Downloads

Our authors are among the

154

Countries delivered to

TOP 1%

most cited scientists

12.2%

Contributors from top 500 universities



WEB OF SCIENCE™

Selection of our books indexed in the Book Citation Index
in Web of Science™ Core Collection (BKCI)

Interested in publishing with us?
Contact book.department@intechopen.com

Numbers displayed above are based on latest data collected.

For more information visit www.intechopen.com



Monitoring of Gaseous Air Pollution

Ryszard J. Katulski¹, Jacek Namieśnik², Jarosław Sadowski¹,
Jacek Stefański¹ and Waldemar Wardencki²

¹Gdansk University of Technology,

¹Department of Radiocommunication Systems and Networks

²Gdansk University of Technology, Department of Analytical Chemistry
Poland

1. Introduction

Air pollution can be defined as the presence in the atmosphere of one or more contaminants in such quality and for such duration as is injurious, or tends to be injurious, to human health or welfare, animal or plant life. It is the contamination of air by the discharge of harmful substances. Industrialization have led to air getting more and more polluted over the years. Industries, vehicles, increase in the population, and urbanization are some of the major factors responsible for air pollution. The following industries are among those that emit a great deal of pollutants into the air: thermal power plants, cement, steel, refineries, petro chemicals, and mines.

Air pollution can cause health problems and it can also damage the environment and property. It has caused thinning of the protective ozone layer of the atmosphere, which is leading to climate change. The source of pollution may be in one country but the impact of pollution may be felt elsewhere. The discovery of pesticides in Antarctica, where they have never been used, suggests the extent to which aerial transport can carry pollutants from one place to another.

The most important tools in environmental protection is monitoring and modeling. Both the monitoring and modeling of air pollution is essential to provide a picture of the damage humans are doing to the environment, and to enable pollution problems to be discovered and dealt with. An environmental monitoring could be defined as a system of detection, measurements, evaluations and forecasts of environmental states, and the collecting, processing and spreading of information on the environment.

Air pollution and its control is a global issue demanding international cooperation. Monitoring of air pollution is a very important source of data. However, measurement of the air pollutant concentrations, in comparison to monitoring of other elements in the environment, is the most difficult. The difficulties arise from the large dynamics of the atmosphere, causing that it constitutes the main route of pollution spreading and their transport between remaining environmental compartments and universal exposure for a large population without a chance for isolation, which is possible in the case of polluted waters and soil. Another problem is low concentration of air pollutants and their interaction with other gases.

This chapter is divided into two parts. In the first, a general information on gaseous air pollution, parameters used to characterize the pollution level and equipment applied for air

monitoring and analysis is presented. Finally, the mobile monitoring system (MMS), as an example of a new approach for air monitoring along communication lanes, proposed by the authors is described.

2. History of air pollution legislation

Concern about urban air quality is not new. First complaints were recorded in the 13th century when coal was first used in London. Today the emphasis has shifted from the pollution problems caused by industry to the pollution in urban areas. A growing concern over the influence of different air pollutants on human health were the main driving force to develop and implement of air quality criteria and standards.

In 1967, the US Congress enacted the Air Quality Acts, the first modern environmental law. The Clean Air Act (Environmental Protection Agency, 2008), which was last amended in 1990, requires the United States Environmental Protection (US EPA) to set National Ambient Air Quality Standards (NAAQS) for pollutants considered harmful to public health and the environment. The Clean Air Act established two types of national air quality standards. *Primary standards* set limits to protect public health, including the health of "sensitive" populations such as asthmatics, children, and the elderly. *Secondary standards* set limits to protect public welfare, including protection against decreased visibility, damage to animals, crops, vegetation, and buildings. The EPA has established NAAQS for six principal pollutants, which are called criteria pollutants: sulphur dioxide, particulate matter, nitrogen oxide, carbon monoxide, ozone and lead. These standards are threshold concentrations based on a detailed review of scientific information related to effects.

In Europe, the first international air quality standards were introduced by the European Commission in 1980 for SO₂ and suspended particulates, mainly aimed at protecting human health. A few years later, the World Health Organization, recognizing ecological damage as being relevant to human health, introduced air quality guidelines for Europe which included the former as well as the latter, later revised in 2000 (World Health Organisation, 2000). The newest directive on ambient air quality and cleaner air of the European Union entered into force in June 2008 (European Union, 2008). It merges four earlier directives and one Council decision into a single directive on air quality. The new directive of the European Union on air quality takes into account concerns from the latest WHO air quality guidelines (WHO, 2005) on fine particles. Reflecting the latest WHO air quality guidelines that identify fine particles (PM_{2.5}) as one of the most dangerous pollutants for human health, the new EU directive sets objectives and target dates for reducing population exposure to PM_{2.5}. It also maintains limits for concentrations of coarser particles known as PM₁₀ and other main pollutants already subject to legislation.

Pollutant levels, especially gaseous, which negatively affect life on earth are nowadays well defined. Table 1 presents examples of air quality standards issued by the Environmental Protection Agency (EPA), the World Health Organization (WHO) and some states (ARMAAG).

3. Regulated air pollutants

The contaminants in ambient air that are of concern are basically categorized as criteria and non criteria pollutants (Griffin, 2007).

Criteria air pollutants are those air contaminants for which numerical concentration limits

Pollutant	Averaging time	WHO	EPA	UE	UK	France	Germany	Poland
SO ₂	10-15 min	500	-	-	266 (not more than 35 times)	-	-	-
	30 min	-	-	-	-	-	-	-
	1h	-	-	350 (not more than 24 times)	350 (not more than 24 times)	350 (not more than 24 times)	350	350 (not more than 24 times)
	3h	-	1300	-	-	-	-	-
	24h	125	365	125 (not more than 3 times)	125 (not more than 3 times)	125 (not more than 3 times)	125	125 (not more than 3 times)
	year	50	80	20	20	20	20	20
NO ₂	30 min	-	-	-	-	-	200	-
	1h	200	-	200 (not more than 18 times)	200 (not more than 18 times)	230 (not longer than 0.2% of time)	-	200 (not more than 18 times)
	24h	-	-	-	-	-	100	-
	year	40	100	40	40	46	-	40
PM10	30 min	-	-	-	-	-	-	-
	24h	20	150	50 (not more than 35 times)	50 (not more than 35 times)	50 (not more than 35 times)	50	50 (not more than 35 times)
	year	50	-	40	40	40	40	40
CO	10-15 min	100000	-	-	-	-	-	-
	30 min	60000	-	-	-	-	-	-
	1h	30000	4000	-	-	-	-	-
	8h	10000	1000	1000	1000	1000	1000	1000
	24h	-	-	-	-	-	-	-
	year	-	-	-	-	-	-	-
O ₃	30 min	-	-	-	-	-	-	-
	1h	-	235	-	-	-	-	-
	8h	100	157	120	100 (not more than 10 times)	120	120	120 (not more than 25 days)
Pb	24h	-	-	-	-	-	5	-
	3 months	-	1.5	-	0.5	-	-	-
	year	0.5	-	0.5	-	0.5	0.5	0.5
Benzene	year	-	-	5	16.25	8	-	5

Table 1. Comparison of limit values [$\mu\text{m}/\text{m}^3$] for a given averaging time, number of exceedances per year issued by different countries and organizations (ARMAAG)

have been set as the dividing line between acceptable air quality and poor or unhealthy air quality. Criteria pollutants include five gases/vapours and two solids: nitrogen oxides (NO_x), sulphur dioxide (SO₂), carbon monoxide (CO), ozone (O₃), benzene, particulate matter (PM₁₀) and lead (Pb). Non criteria pollutants are those contaminants designated as toxic or hazardous by legislation or regulation. They fall in two further subcategories, depending on the legislation that defines them. In general, hazardous air pollutants may pose a variety of health effects, whereas the toxic focus on one physiological response.

4. Characteristics of criteria air pollutants

Air pollutants arise from a wide variety of sources although they are mainly a result of the combustion process (Friedrich & Reis, 2004). The largest sources include power generation, motor vehicle and industry. The emissions of pollutants into the atmosphere badly influence vegetation, human and animal life, agriculture and climate. Emissions of carbon monoxide (CO), nitrogen oxides (NO_x) and hydrocarbons (HC) are controlled by catalytic converters on new gasoline driven cars. Emissions of sulphur oxides are being reduced through lower sulphur content in gasoline. However, emissions of particulate matter are not decreasing. Any successful strategies for controlling or countering these problems must be based on reliable air quality monitoring data for management, to make informed decisions on air pollution control.

Volatile organic compounds (VOCs) is a collective name for a very large number of different chemical species, including hydrocarbons, halocarbons and oxygenates that have different physico-chemical properties and are directly emitted from both anthropogenic and natural sources, and which can contribute to the formation of secondary pollutants with different efficiencies. For vehicular emissions, the list of compounds is long and variable depending on fuel, type of engine, and operating conditions. Hydrocarbons such as ethane, ethyne, higher aliphatic hydrocarbons, benzene, toluene, and xylenes (BTX) are typical emissions in most cases. Each of these compounds can be released unreacted or can undergo oxidation reactions. One of them, benzene, is found in the highest concentrations. Ambient concentrations are typically between 1-50 ppb but close to major emissions can be as high as several hundred ppb. In the unreacted state, it has undesirable ecotoxicological properties. Besides causing annoying physiological reactions such as dizziness and membrane irritation, it is known to be a human carcinogen.

The two nitrogen oxides, NO and NO₂ (together called NO_x) from anthropogenic sources are present as a consequence of various combustion processes from both stationary sources, i.e. power generation (21%) and mobile sources, i.e. transport (44%). These species have very short atmospheric lifetimes, around five days, being ultimately converted to nitric acid and removed in rainfalls. However, nitrogen oxide is important because it is a precursor to tropospheric ozone. Whereas NO does not affect climate, ozone does. A typical sea-level mixing ratio of NO is 5 ppt (parts per trillion, 1:10¹²) but in urban regions, NO mixing ratios reach 0.1 ppm in the early morning, but decrease to zero by midmorning due to their reaction with ozone. A major source of NO₂ is oxidation of NO, being intermediary between NO emission and O₃ formation. Nitrogen dioxide is one of the six criteria air pollutants for which ambient standards are set by the US EPA under CAAA70 (Clean Air Act Amendments of 1970). In urban regions, the mixing ratio of NO₂ ranges from 0.1 to 0.25 ppm. It is more prevalent during midmorning than during midday or afternoon because sunlight breaks down most NO₂ past midmorning. Exposure to high concentrations of NO₂

harms the lungs and increases respiratory infections. It may trigger asthma by damaging or irritating and sensitizing the lungs, making people more susceptible to allergens. At higher concentrations, it can result in acute bronchitis or death.

Sulfur dioxide (SO₂) is a strong smelling, colorless gas that is formed by the combustion of fossil fuels, smelting, manufacture of sulfuric acid, conversion of wood pulp to paper, incineration of refuse and production of elemental sulphur. Power plants, which may use coal or oil high in sulfur content, can be major sources of SO₂ accounting for about 50 % of annual global emissions. SO₂ and other sulfur oxides contribute to the problem of acid deposition and can be major contributors to smog. Natural background levels of SO₂ are about 2 ppb. Hourly peak values can reach 750 ppb on infrequent occasions. Sulphur dioxide can lead to lung diseases. SO₂ is a criteria air pollutant.

Ozone (O₃) is not directly emitted from both anthropogenic and natural sources. Its only source into air is chemical reaction. In urban air, ozone mixing ratios range from less than 0.01 ppm at night to 0.5 ppm (during afternoons in the most polluted cities world wide), with typical values of 0.15 ppm during moderately polluted afternoons. Ozone causes headaches at concentrations greater than 0.15 ppmv, chest pains at mixing ratios greater than 0.25 ppm, and a sore throat and coughing at mixing ratios greater than 0.30 ppm. Exceeding a level of 0.30 ppm decreases lung functions. Respiratory symptoms include coughing and breathing discomfort. Ozone can also accelerate the aging of lung tissue. It also interferes with the growth of plants and deteriorates organic materials, such as rubber, textiles and some paints and coatings. Furthermore, ozone increases plant and tree stress and their susceptibility to disease, infestation and death.

Particulate matter (PM) in the atmosphere, frequently described simply as particle pollution, arises from natural sources, such as windborne dust, sea spray, and volcanoes and from anthropogenic activities, such as combustion of fuels. Particle pollution in the air includes a mixture of solids and liquid droplets and come in a wide range of sizes. Those less than 10 micrometers in diameter (PM₁₀) are so small that they can enter the lungs, potentially causing serious health problems. Particles less than 2.5 micrometers in diameter are called fine particles. These particles are so small they can only be detected with an electron microscope. Sources of fine particles include all types of combustion, including motor vehicles, power plants, residential wood burning, forest fires, agricultural burning, and some industrial processes. Particles between 2.5 and 10 micrometers in diameter are referred to as coarse. Sources of coarse particles include crushing or grinding operations, and dust stirred up by vehicles traveling on roads. After being released into the air, particles can change their size and composition by condensation of vapour species or by evaporation, by coagulating with other particles or by chemical reaction. Particles smaller than 1 µm in diameter generally have atmospheric concentrations in a range from around ten to several thousand per cm³; those exceeding 1 µm diameter are usually found at concentrations less than 1 cm⁻³.

Carbon monoxide (CO) is a colourless, odourless gas that is produced by the incomplete burning of carbon-based fuels including petrol, diesel and wood. It is also produced from the combustion of natural and synthetic products such as cigarettes. Natural background levels of CO fall in a range of 10-200 ppb. Levels in urban areas are highly variable, depending upon weather conditions and traffic density. 8-hour mean values are generally less than 10 ppm but sometimes can be as high as 500 ppm. Carbon monoxide lowers the amount of oxygen that enters the blood. It can slow human reflexes and may make people confused and sleepy.

5. Air pollution monitoring networks

For the purpose of monitoring and reporting of air pollution, most industrialised countries have been divided into regions or zones and urban areas or agglomerations, e.g. in Europe in accordance with EC Directive 96/62/EC (European Union, 1996). This Directive sets a framework for ways to monitor and report ambient levels of air pollutants. Other directives set ambient air limit values for particular pollutants:

- Directive 99/30/EC for nitrogen dioxide and oxides of nitrogen, sulphur dioxide, lead and particulate matter,
- Directive 2000/69/EC for benzene and carbon monoxide,
- Directive 2002/3/EC for ozone.

The monitoring sites are organized into automatic and non-automatic networks (national, regional and local) that gather a specific kind of information using a particular method. For example, across the UK there are over 1500 monitoring sites which monitor air quality and these are organized into networks (automatic and non-automatic) that gather a specific kind of information, using a particular method. The pollutants measured and the method used by each network depend on the reason for setting up the network, and what the data is to be used for. In Poland, the monitoring of air quality has been performed systematically since 1992, mainly by using automatic air monitoring stations. National network comprises 81 specialized monitoring stations, where basic pollutants are measured everyday (CO, CO₂, SO_x, NO_x, HCl and particulate matter PM₁₀ and PM_{2,5}). Regional and local networks comprises 390 stations localized in cities over 20 000 citizens and additionally 60 stations in spas.

The obtained information concerns different types of concentrations of investigated pollutants depending on applied sampling techniques and a measuring period. The results of measurements may be referred to in real time (instantaneous concentrations) or to a selected period of time (e.g., 1-hr, 8 hrs, 24-hrs, month, year). Final measurements represent averaged concentrations. The obtained data from air monitoring is used in air quality inventories and bulletins.

Considering the frequency of discrete sampling, periodic and instantaneous measurements are distinguished. Taking into account space, parameter measurements are divided to a point, averaged along a defined part of space and averaged on the selected area. Point monitoring is inadequate to measure poorly mixed gases such as fugitive emissions over large areas. If the point instrument is wrongly placed, measurement results are not representative. Final measurements enable the determination of weighted average concentrations over the sampling period.

6. General characteristic of instruments for air monitoring

The earliest air quality measurements used relatively simple, manual techniques. Often a sample was collected at a site and then returned to a laboratory for analysis. This is, in fact, still a common practice today, due to the relative low cost and high reliability of these types of measurements. Since seventieth of the XX century the automatic analyzers were introduced to the monitoring networks. These had the benefit of low labour costs and could provide highly resolved, continuous measurements. These continuous measurements became a requirement for regulatory purposes and so, in many cities urban monitoring network was established to monitor compliance with the emerging EC Directive limit values

on air quality. The networks were subsequently expanded, following commitments by different governments to expand urban monitoring in particular countries and improve public availability of air quality information.

The basic requirement of the analyzers for air monitoring is high measurement sensitivity, i.e. a low limit of detection (LOD) and low limit of quantitation (LOQ). It gives a chance for the detection of pollutants at required levels. Instruments which should acquire analytical data in real time or only with a small time delay, have to be equipped with the following additional capabilities:

- provide high resolution data (characterized by a low response time),
- provide automatic calibration and zeroing,
- extended operation without service or maintenance.

The last demand means that they should be equipped with an independent power supply and be able to automatically regenerate or exchange worn out filters and, depending on the type of detector (sensor) used, fulfill special demands, e.g., for electrochemical sensors, exchange or supplement the working solution and reagents, and in devices with FID or FPD detection, protect against flame extinguishing.

Analytical instruments currently used for the detection and determination of atmospheric pollutants can be classified according to various criteria (Wardencki et al., 2008).

Recently, measuring techniques based on a physical (or physicochemical) principle, have been used more frequently in the assessment of air quality. Such methods involve the direct determination of a physical property of a pollutant, sometimes after its interaction with another compound. In this approach, better stability, sensitivity and reliability may be easily achieved. Furthermore, the practical application requires less maintenance. Instruments based on this principle can be easily automated, which enables their use in providing continuous measurements needed for up-to-date assessments of air quality. It is especially relevant to environmental monitoring because many existing standards refer to a specified period of time, i.e. 1 hour, 24 hours or a year.

According to the location where measurements are taken, instruments can be stationary or *on-site*. In the first case, analysis is performed in the laboratory and sophisticated instruments are used, such as mass, electron mobility or X-ray fluorescence spectrometers. *On-site* systems enable measuring pollution levels in the field. Since access to a sophisticated laboratory is not required, the devices (usually uncomplicated, relatively cheap and portable) hold great promise for use in remote locations. The main advantage of on-site analysis is the potential for rapid assessment and response to a particular problem.

All monitoring systems can be classified as mobile or stationary. Most existing systems which monitor gaseous pollutants of atmospheric air and ambient aerosols, both automatic and manual, usually perform stationary measurements, i.e. they are directly linked to a specific point or space in the vicinity of that point. Based on the data obtained from a single monitoring site, it is not possible to assess spatial and temporal variations of air pollutants.

Mobile refers to a continuous-monitoring instrument that is portable or transportable. They are usually designed to perform analytical measurements without preliminary operations. Portable refers to a self-contained, battery-operated device, which may be worn or carried by the person using it, or may require the use of special vehicles for placement in a specific area to be monitored. Transportable gas monitors can be mounted on a vehicle such as a car, plane, balloon, ship or space shuttle, but not to a mining machine or an industrial truck.

For mobile systems, registered values of pollutants have to be correlated with information about the geographical site and actual meteorological conditions (temperature and humidity).

Several contributions published during the last decade have proven the advantages of mobile systems in getting information concerning the spatial and temporal distribution of atmospheric trace gases, without the need of a dense network of stationary stations. Most of the proposed systems are based on the application of mobile laboratories (Bukowiecki et al., 2002), (Gouriou et al., 2004), (Pirjola et al., 2004), equipped with appropriate monitors. There are also systems which allow the measurement of pollutants in a stream of vehicles, but a measuring unit is installed on any vehicle (Katulski et al., 2006, 2007) rather than attached to a dedicated van (Seakins et al., 2002), (Bogo et al., 1999).

The general trend in the field of creating instruments for air quality assessment is combining several instruments into one system and forming so called hybrid multisensor systems, controlled by a microprocessor capable of transferring the obtained data to a central station, frequently using a wireless system. In the central station, the data is collected both from single objects (houses, plants) or from larger areas. Many systems are equipped with devices for testing the sensors and for providing a diagnosis of the whole instrument. They frequently have alarms which warn the user of any dangerous situation due to the breaching of some value limit. Such systems are battery-powered and able to work continuously for several days or months.

The environments in which analyzers are used differ from the relative calm of the laboratory. Analyzers have to withstand wide ambient temperatures, fluctuations and vibrations. Due to this, many systems are completely sealed so as to operate independent of outside conditions and to be able to withstand the onslaught of monkey-wrench mechanics.

7. Description of mobile system for on-road measurements of air pollutants

The developed prototype of monitoring system consists of an original equipment measuring in motion the gaseous pollution of atmospheric air, further called ARPOL (the acronym stems from ARMAAG - Agency of Regional Monitoring of Atmosphere of Gdańsk Agglomeration and Gdańsk POLytechnic), which is designed to test the pollution of atmospheric air with the following chemical compounds: C₆H₆, NO₂, NO_x, CO and CO₂. The equipment can be installed on any mobile vehicle like a bus or taxicab, relay the results of concentration measurements in air of the substances outlined above to a server which plays the role of a database, along with information on vehicle location and speed as well as the temperature and humidity of air at the measurement spot. Data transmission between the equipment and the server is effected with the use of a radio modem operating in GSM/GPRS systems.

An ARPOL monitoring station has been developed and built in the laboratory of the Department of Radiocommunication Systems and Networks at Gdańsk University of Technology. The set of commercially available gas concentration sensors in air has been selected by researchers from the Chemical Faculty of Gdańsk University of Technology and the ARMAAG Foundation. The construction of the system falls into line with requirements of the sensors and the anticipated application. In the result of decisions taken it has been established to use semiconductor (thick-film) sensors of the newest generation, made of nanostructures with grain-size distribution from 30 to 50 nm. After preliminary investigations the following sensor (all from Figaro Engineering Inc from Osaka, Japan)

were chosen: TGS2442 for CO, TGS4161 for CO₂, TGS823 for benzene, TGS2106 for NO₂ and TGS2201 for NO_x. Some of these sensors were designed for measurement of gases in ppm (parts per million, 10⁻⁶) concentration, but the concentration of NO_x, CO or C₆H₆ in typical air condition is of the order of ppb (parts per billion, 10⁻⁹). However, comparison of results from several months of measurements proved that after proper calibration and compensation of air temperature and humidity, they were enough stable and precise for determining the sources and regions of highest pollution caused by road traffic. All of the gas concentration sensors are heated using internal heaters as a substrate for sensing structure. The temperature of substrate cannot be controlled because no temperature sensor is built in the substrate of gas-sensing element. Correction of substrate temperature change caused by change in temperature of air flowing around the sensor is made by measuring the temperature of air using additional semiconductor sensor and proper calibration equations. Proper heating of gas concentration sensors takes up to several tens of minutes. During this period results of measurements cannot be considered as a reliable results. Also any break in powering the sensors makes results unstable for some unpredictable time (up to several minutes) so monitoring device with such sensors need to provide uninterrupted heating of sensors during whole measurement campaign. Special electronic circuits ensure high sensitivity and high accuracy of measurements.

In the design of ARPOL a microcontroller of the AtMega series (supplier: Atmel Corporation from San Jose, USA) with built-in analog-to-digital converters has been used; the microcontroller circuit has been connected to a ready-made GSM/GPRS modem board (supplier: Enfora from Richardson, USA) and a GPS signal receiver (supplier: Trimble Navigation Ltd. from Sunnyvale, USA), as well as a series RS232 interface (RS232 signal converter based on Maxim chip, supplier: Maxim Integrated Products Inc. from Sunnyvale, USA) and the required additional supply circuits. The main board has been also provided with a connector for the attachment of a board with possible additional sensors not foreseen in the original design, and transoptor circuits and actuators which allow to apply control signals.

To ensure highest immunity of the equipment against shocks it was decided that the whole electronic circuitry of the main part of ARPOL will be assembled on one printed board. As some devices of the equipment (power supply circuits in particular) may heat up during normal operation, it has been decided to place all chemical sensors and the external temperature and air humidity sensors at one edge of the main board, so that the microprocessor part with power supplies could be separated in the housing from the sensors by means of an appropriate dividing partition.

The equipment has been enclosed in a housing which provides protection of the system from the influence of precipitation, while simultaneously allowing access of atmospheric air to the gas-concentration, temperature and humidity sensors. The housing permits the unit to be mounted both in a car and stationary at selected points in town. Part of the electronic board with sensors has been enclosed in a plastic channel terminated with an air in- and outlet, provided with additional "roofs" for protection from rain. In order to reduce the effect of exhaust gas of the engine the unit has forced sampling system opening towards the driving direction. To ensure an uniform air exchange, in the channel with sensors a blower has been placed, provided with revolution control - a blower failure or reduction of its efficiency resulting in a decrease of air flow in the measurement channel is registered by a microcontroller as an alarm state.

A schematic description of the operation of the mobile monitoring system (MMS) for testing and analysis of atmospheric air pollution along road traffic arteries is presented in Fig.1. This system consists of an ARPOL unit mounted on a vehicle and a WWW server in which a database for collection and processing of measurement data has been established. The values of concentration of chemical compounds polluting the atmosphere are transmitted through radio, through the mobile GSM/GPRS network and the Internet network to a WWW server located anywhere, e.g. at Gdańsk University of Technology (Gdańsk Polytechnic). There, these data are processed and verified as to their credibility. Subsequently, they are sorted according to the measurement date and, if needed, displayed on the monitor of an authorized user by a common WWW page browser.

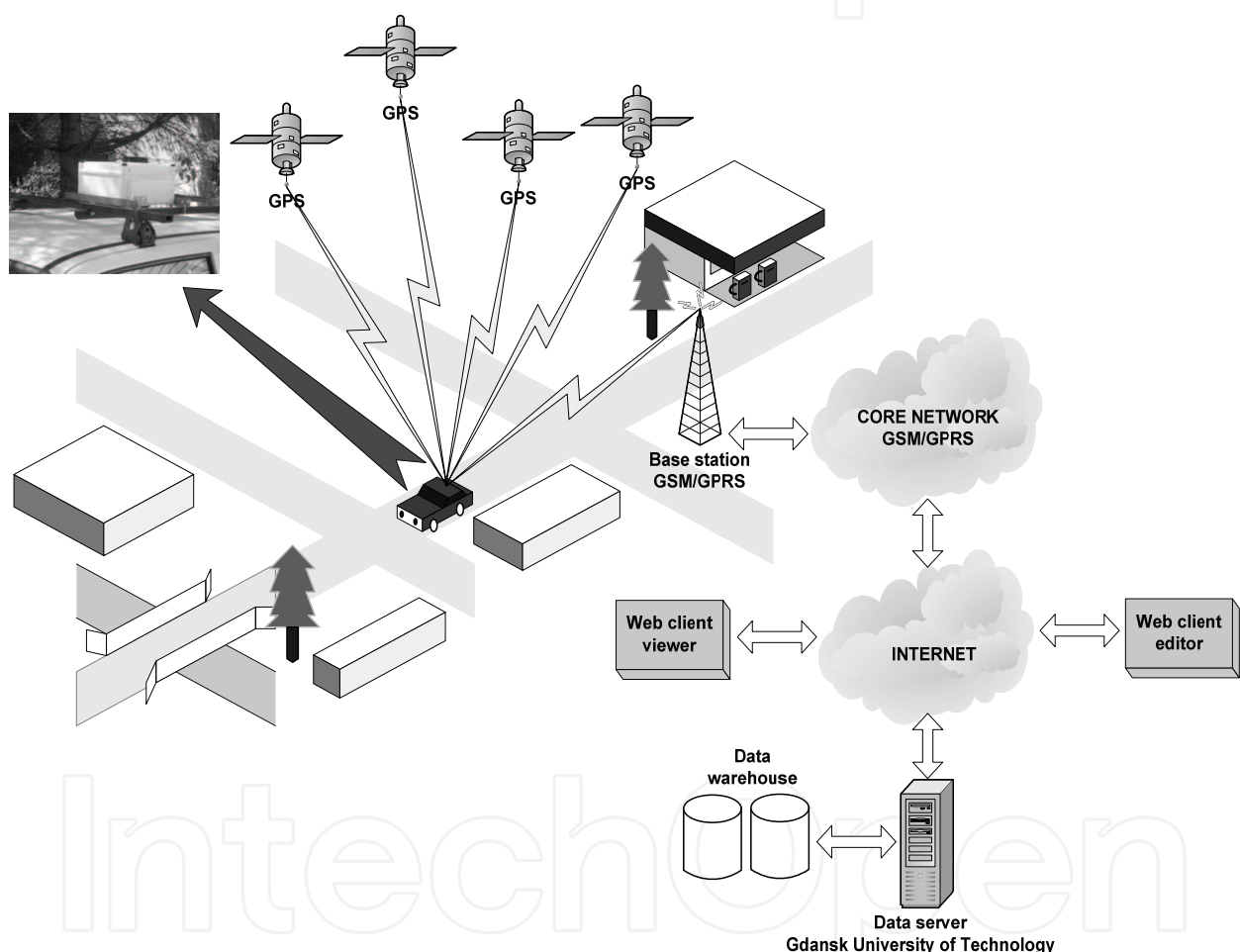

Fig. 1. The concept of the mobile monitoring system for chemical agents control in the air.

To achieve simplicity of operation of the monitoring system, the configuration process of ARPOL unit and the WWW server is kept to a minimum. This means that this system can be implemented on a wide range of servers.

The proposed monitoring unit can be described as maintenance-free. Properly configured and set-up monitoring station can operate for several months without intervention. Information about the state of a device and possible errors in the functioning of electronic components or problems with data collection are transmitted to respective person via short messages (SMS).

8. Sensors description

Road traffic is responsible for emission of several air pollutants, the most important being nitrogen oxides (NO and NO₂, together called NO_x) which may harm the lungs and trigger asthma, sulphur dioxide (SO₂), particulate matter (PM), carbon monoxide (CO), carbon dioxide (CO₂) and volatile organic compounds (VOCs) which can contribute to the formation of secondary pollutants with different efficiencies. The measurement of particulate matter in air requires some air filtering and mass measuring during specified time which cannot be made using semiconductor sensors and is not applicable to mobile monitoring units. Other air pollutants can be measured using thick film semiconductor sensors. Prototypes of monitoring units for proposed systems use selected sensors made by Figaro:

- TGS2442 - CO sensor, response: resistance of SnO₂ layer on electrical insulation layer. Response time: tens of seconds;
- TGS4161 - CO₂ sensor, response: electromotive force which is the result of electrochemical reaction of CO₂ and electrodes made of gold and lithium carbonate with cation (Na⁺) solid electrolyte. Response time: up to 1 minute, recovery time: up to 2.5minutes;
- TGS823 - VOC sensor. This sensor reacts to the presence of several volatile organic compounds, such as: Benzene (C₆H₆), Ethanol, n-Hexane, Acetone, Isobutane and others, but is used mostly for detection of Benzene which is found in highest concentrations. Response: resistance of SnO₂ layer, response time: tens of seconds;
- TGS2106 - NO₂ sensor, response: resistance of metal-oxide semiconductor layer. Response time: several seconds;
- TGS2201 - NO_x and CO sensor (double) used only for NO_x measurement, response: resistance of metal-oxide semiconductor layer. Response time: tens of seconds.

Some of these sensors were designed for measurement of gases in ppmv (parts per million, 10⁻⁶) concentration, but the concentration of NO_x, CO or C₆H₆ in typical air condition is of the order of ppbv (parts per billion, 10⁻⁹). However, comparison of results from several months of measurements proved that after proper calibration and compensation of air temperature and humidity, they are enough stable and precise for determining the sources and regions of highest pollution caused by road traffic.

9. Air monitoring unit

Block diagram of mobile monitoring unit is presented in Fig.2. This version of measurement device is made of sensor unit, A/D converters and microcontroller to convert sensor's electric response to gas concentrations. Microcontroller is also responsible for linking measurement results with geographic coordinates from GPS and sending these data to server using GSM/GPRS link. The interior of one of monitoring units built in Gdansk University of Technology laboratory is shown in Fig.3.

The gas concentration sensors together with temperature and humidity sensors are put inside manifold (at the top of Fig.3). Air flow inside manifold is forced by fan, which rotate speed is controlled by microprocessor because change in flow rate will change gas sensor's substrate temperatures as air is cooling the casings of sensors.

Electrical response of gas sensors is converted into voltage signals using very high impedance operational amplifier (for EMF output) or by resistive voltage divider (for

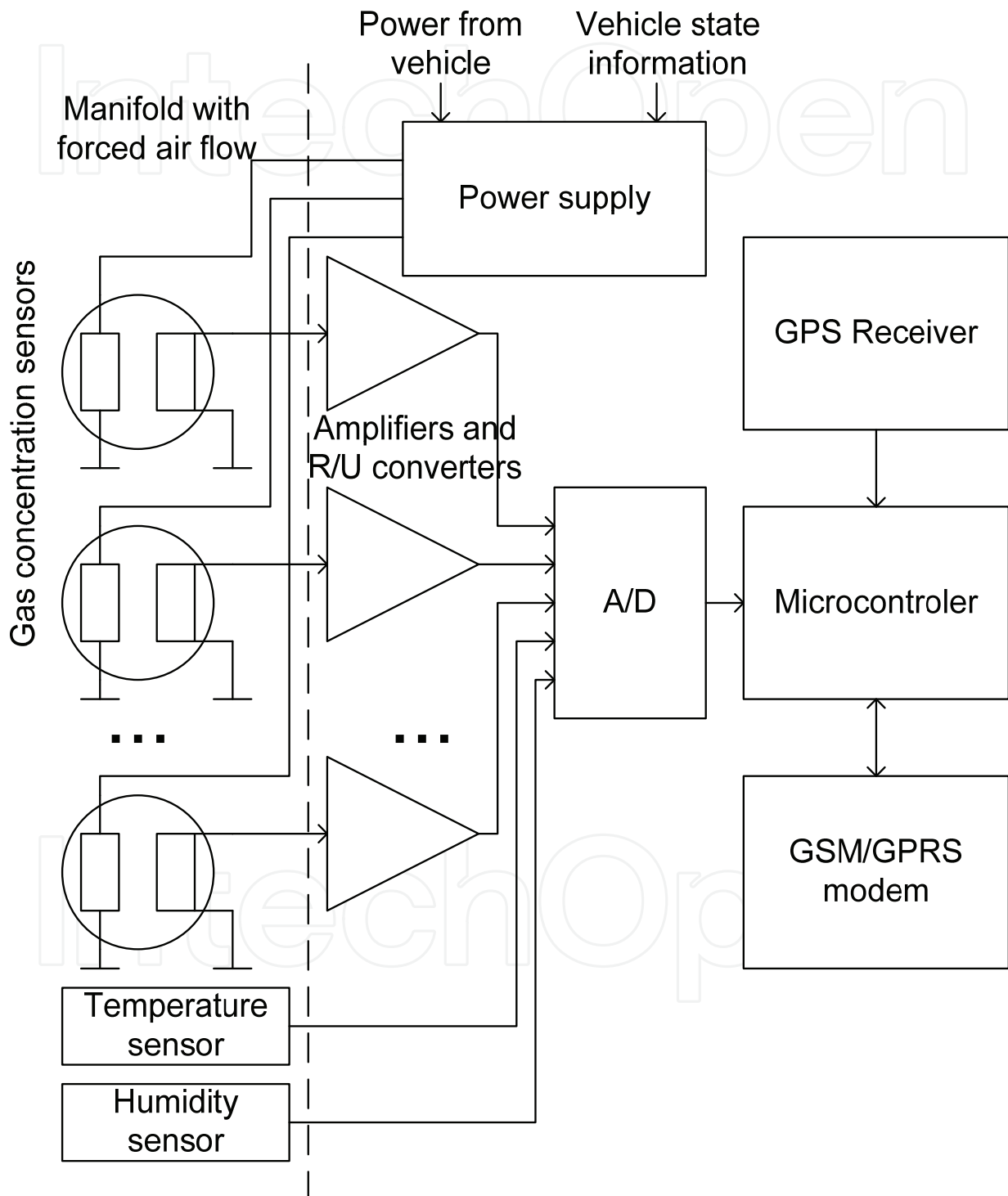

Fig. 2. Block diagram of mobile monitoring unit.



Fig. 3. Mobile monitoring unit prototype.

resistive output). Then the signals are passing low-pass filters with cutoff frequency about 10Hz for all sensors except TGS2442 which requires pulsed resistance measurement and therefore filter cutoff frequency has to be greater than 100Hz. Additional noise-filtering is made by microprocessor which averages digital values after A/D conversion during 10 seconds period. Averaged digital values are being transmitted to server without any additional conversion. Calculation of gas concentration is made by server using nonlinear

equations derived during calibration procedure. Other data sent to server in every packet are:

- monitoring unit identification number;
- geographical coordinates of measurement point (from GPS receiver);
- speed and direction of movement (from GPS receiver);
- date/time of measurement (from GPS receiver);
- temperature and humidity of air in manifold;
- temperature of electronic circuits outside manifold;
- external or internal power supply voltage;
- state of vehicle engine in case of mounting the device on car/bus;
- error flags which indicate condition of monitoring unit.

Data transmission uses GPRS/EDGE radio link and TCP/IP protocol stack. To avoid writing special software at server side, data records are encoded as special HTTP request. Such requests are easily handled by PHP script and after decoding raw data records are written to MySQL database.

10. Conclusions

Polluted air negatively influences health and in some cases may even lead to death. Therefore, the issue of air quality is now a major concern for many countries which have been working to improve air quality by controlling emissions of harmful substances into the atmosphere, improving fuel quality, and by integrating environmental protection requirements into the transport and energy sectors. Despite these improvements in air quality over recent years, the problem of air pollution still remains. Therefore, more needs to be done at local, national, European and international levels.

Monitoring of air pollution is a prerequisite of air quality control and is carried out by a wide variety of analytical methods employing different measurement instruments which have different sensitivities and specificities. Monitoring plays a critical role in protecting the environment and is a key element of all actions related with the management and protection of ambient air.

According to existing law, member countries of the European Union are obliged to carry out measurements of atmospheric air cleanness and to introduce preventive measures against excessive pollution exceeding allowable threshold limits. To meet these obligations, the member countries are required to prepare inventories of zones and agglomerates where transgression of limiting norms occurs, and to prepare and introduce plans and programs how to adhere to the parameters required by law. Thus the mobile monitoring system described here, called ARPOL, unique on the national scale, can upgrade the existing system of measuring atmospheric air cleanness and facilitate taking appropriate decisions through analysis of various emission scenarios.

The developed device forms part of an expert system which undoubtedly contributes to the enhancement of ecological safety in a given area. It may be a cheap and useful tool (considering low investment and exploitation costs) for assessing ecological effects of new efforts for limiting pollutants emissions rather than for assessment of air quality. It contributes to more careful environmental planning by extending the measurement basis with information from non-stationary sources.

11. References

- Environmental Protection Agency (2008). Clean Air Act, in: *U.S. Code*, 03.2011, Available from <http://www.epa.gov/air/caa/>
- World Health Organisation (2000). *Air Quality Guidelines for Europe*, 2nd edition, WHO Regional Publications European Series No.91, Copenhagen, 2000.
- European Union (2008). Directive 2008/50/EC of the European Parliament and of the Council of 21 May 2008 on ambient air quality and cleaner air for Europe, Official Journal of the European Union, 11.6.2008, L. 152/1-152/44
- WHO (2005). WHO Air quality guidelines for particulate matter, ozone, nitrogen dioxide and sulfur dioxide - Global update 2005 - Summary of risk assessment
- ARMAAG. Emission limits values (in Polish), 03.2011, Available from <http://armaag.gda.pl/normy.htm>
- Griffin, R.D. (2007). *Principles of air quality management*, Taylor & Francis Group, Boca Raton, 2007
- Friedrich, R. & Reis, S. (2004). *Emission of Air Pollutants*. Springer_Verlag Berlin Heidelberg, 2004
- European Union (1996). Council Directive 96/62/EC of 27 September 1996 on ambient air quality assessment and management . Official Journal L 296 , 21/11/1996 P. 0055 - 0063
- Wardencki, W., Katulski, R. Stefański J. & Namieśnik, J. (2008). *The state of the art in the field of non-stationary instruments for the determination and monitoring of atmospheric pollutants*. Critical Reviews in Analytical Chemistry, 2008, 38, 1-10.
- Bukowiecki, N., Dommen, J., Prevot, A.S.H, Richter, R., Weingartner, E. & Baltensperger U. (2002). *A mobile pollutant measurement laboratory-measuring gas phase and aerosol ambient concentrations with high spatial and temporal resolution*. Atmospheric Environment, 2002, 36, 5569-5579.
- Gouriou, F., Morin, J-P. & Weill, M-E. (2004). *On-road measurements of particle number concentrations and size distributions in urban and tunnel environments* Atmospheric Environment, 2004, 38 (18), 2831-2840.
- Pirjola, L., Parviainen, H., Hussein, T., Valli, A., Hameri, K., Aalto, P., Virtanen, A., Keskinen, J., Pakkanen, T.A., Makela, T. & Hillamo, R.E. (2004). *'Sniffer'-a novel tool for chasing vehicles and measuring traffic pollutants*. Atmospheric Environment, 2004, 38, 3625-3635.
- Katulski, R., Stefański, J., Wardencki, W. & Żurek J. (2006). Concept of the mobile monitoring system for chemical agents control in the air, Proceedings of the *IEEE Conference on Technologies for Homeland Security - Enhancing Transportation Security and Efficiency*, June 7-8, 2006, Boston, USA, 181-184.
- Katulski, R., Stefański, J., Wardencki, W. & Żurek J. (2007). The Mobile Monitoring System (MMS) - a Useful Tool for Assessing Air Pollution in Cities, Proceedings of the *Pittsburgh Conference on Analytical Chemistry and Applied Spectroscopy PITTCON'2007*, February 25 - March 2, 2007, Chicago, USA.

Seakins, P.W, Lansley, D.L, Hodgson, A., Huntley A. & Pope, F. (2002), *New Directions: Mobile laboratory reveals new issues in urban air quality*, *Atmospheric Environment* 2002, 36, 1247-1248.

Bogo H., Negri R.M. & San Roman, E. (1999). *Continuous measurement of gaseous pollutants in Buenos Aires city*. *Atmospheric Environment*, 1999, 33, 2587 - 2598.

IntechOpen

IntechOpen

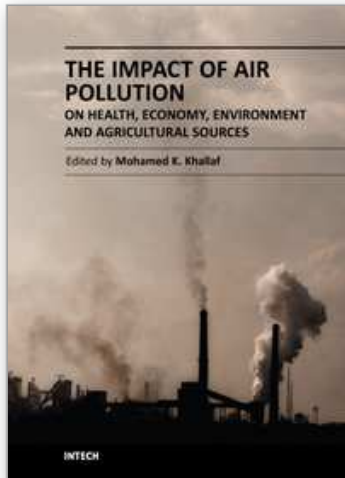

The Impact of Air Pollution on Health, Economy, Environment and Agricultural Sources

Edited by Dr. Mohamed Khallaf

ISBN 978-953-307-528-0

Hard cover, 444 pages

Publisher InTech

Published online 26, September, 2011

Published in print edition September, 2011

This book aims to strengthen the knowledge base dealing with Air Pollution. The book consists of 21 chapters dealing with Air Pollution and its effects in the fields of Health, Environment, Economy and Agricultural Sources. It is divided into four sections. The first one deals with effect of air pollution on health and human body organs. The second section includes the Impact of air pollution on plants and agricultural sources and methods of resistance. The third section includes environmental changes, geographic and climatic conditions due to air pollution. The fourth section includes case studies concerning of the impact of air pollution in the economy and development goals, such as, indoor air pollution in México, indoor air pollution and millennium development goals in Bangladesh, epidemiologic and economic impact of natural gas on indoor air pollution in Colombia and economic growth and air pollution in Iran during development programs. In this book the authors explain the definition of air pollution, the most important pollutants and their different sources and effects on humans and various fields of life. The authors offer different solutions to the problems resulting from air pollution.

How to reference

In order to correctly reference this scholarly work, feel free to copy and paste the following:

Ryszard J. Katulski, Jacek Namieśnik, Jarosław Sadowski, Jacek Stefański and Waldemar Wardencki (2011). Monitoring of Gaseous Air Pollution, The Impact of Air Pollution on Health, Economy, Environment and Agricultural Sources, Dr. Mohamed Khallaf (Ed.), ISBN: 978-953-307-528-0, InTech, Available from: <http://www.intechopen.com/books/the-impact-of-air-pollution-on-health-economy-environment-and-agricultural-sources/monitoring-of-gaseous-air-pollution>

INTECH
open science | open minds

InTech Europe

University Campus STeP Ri
Slavka Krautzeka 83/A
51000 Rijeka, Croatia
Phone: +385 (51) 770 447
Fax: +385 (51) 686 166
www.intechopen.com

InTech China

Unit 405, Office Block, Hotel Equatorial Shanghai
No.65, Yan An Road (West), Shanghai, 200040, China
中国上海市延安西路65号上海国际贵都大饭店办公楼405单元
Phone: +86-21-62489820
Fax: +86-21-62489821

© 2011 The Author(s). Licensee IntechOpen. This chapter is distributed under the terms of the [Creative Commons Attribution-NonCommercial-ShareAlike-3.0 License](#), which permits use, distribution and reproduction for non-commercial purposes, provided the original is properly cited and derivative works building on this content are distributed under the same license.

IntechOpen

IntechOpen