

# We are IntechOpen, the world's leading publisher of Open Access books Built by scientists, for scientists

4,800

Open access books available

122,000

International authors and editors

135M

Downloads

Our authors are among the

154

Countries delivered to

TOP 1%

most cited scientists

12.2%

Contributors from top 500 universities



WEB OF SCIENCE™

Selection of our books indexed in the Book Citation Index  
in Web of Science™ Core Collection (BKCI)

Interested in publishing with us?  
Contact [book.department@intechopen.com](mailto:book.department@intechopen.com)

Numbers displayed above are based on latest data collected.  
For more information visit [www.intechopen.com](http://www.intechopen.com)



# Optimal Resource Allocation in OFDMA Broadcast Channels Using Dynamic Programming

Jesús Pérez, Javier Vía and Alfredo Nazábal  
*University of Cantabria  
Spain*

## 1. Introduction

OFDM (Orthogonal Frequency Division Multiplexing) is a well-known multicarrier modulation technique that allows high-rate data transmissions over multipath broadband wireless channels. By using OFDM, a high-rate data stream is split into a number of lower-rate streams that are simultaneously transmitted on different orthogonal subcarriers. Thus, the broadband channel is decomposed into a set of parallel frequency-flat subchannels; each one corresponding to an OFDM subcarrier. In a single user scenario, if the channel state is known at the transmitter, the system performance can be enhanced by adapting the power and data rates over each subcarrier. For example, the transmitter can allocate more transmit power and higher data rates to the subcarriers with better channels. By doing this, the total throughput can be significantly increased.

In a multiuser scenario, different subcarriers can be allocated to different users, which constitutes an orthogonal multiple access method known as OFDMA (Orthogonal Frequency Division Multiple Access). OFDMA is one of the principal multiple access schemes for broadband wireless multiuser systems. It has been proposed for use in several broadband multiuser wireless standards like IEEE 802.20 (MBWA: <http://grouper.ieee.org/groups/802/20/>), IEEE 802.16 (WiMAX: <http://www.ieee802.org/16/>, 2011) and 3GPP-LTE (<http://www.3gpp.org/>). This chapter focuses on the OFDMA broadcast channel (also known as downlink channel), since this is typically where high data rates and reliability is needed in broadband wireless multiuser systems. In OFDMA downlink transmission, each subchannel is assigned to one user at most, allowing simultaneous orthogonal transmission to several users. Once a subchannel is assigned to a user, the transmitter allocates a fraction of the total available power as well as a modulation and coding (data rate). If the channel state is known at the transmitter, the system performance can be significantly enhanced by allocating the available resources (subchannels, transmit power and data rates) intelligently according to the users' channels. The allocation of these resources determines the quality of service (QoS) provided by the system to each user. Since different users experience different channels, this scheme does not only exploit the frequency diversity of the channel, but also the inherent multiuser diversity of the system.

In multiuser transmission schemes, like OFDMA, the information-theoretic system performance is usually characterized by the capacity region. It is defined as the set of rates

that can be simultaneously achieved for all users (Cover & Thomas, 1991). OFDMA is a suboptimal scheme in terms of capacity, but near capacity performance can be achieved when the system resources are optimally allocated. This fact, in addition to its orthogonality and feasibility, makes OFDMA one of the preferred schemes for practical systems. It is well known that coding across the subcarriers does not improve the capacity (Tse & Viswanath, 2005), so maximum performance is achieved by using separate codes for each subchannel. Then, the data rate received by each user is the sum of the data rates received from the assigned subchannels. The set of data rates received by all users for a given resource allocation gives rise to a point in the rate region. The points of the segment connecting two points associated with two different resource allocation strategies can always be achieved by time sharing between them. Therefore, the OFDMA rate region is the convex hull of the points achieved under all possible resource allocation strategies.

To numerically characterize the boundary of the rate region, a weight coefficient is assigned to each user. Then, since the rate region is convex, the boundary points are obtained by maximizing the weighted sum-rate for different weight values. In general, this leads to non-linear mixed constrained optimization problems quite difficult to solve. The constraint is given by the total available power, so it is always a continuous constraint. The optimization or decision variables are the user and the rate assigned to each subcarrier. The first is a discrete variable in the sense that it takes values from a finite set. At this point is important to distinguish between continuous or discrete rate adaptation. In the first case the optimization variable is assumed continuous whereas in the second case it is discrete and takes values from a finite set. The later is the case of practical systems where there is always a finite codebook, so only discrete rates can be transmitted through each subchannel. Unfortunately, regardless the nature of the decision variables, the resulting optimization problems are quite difficult to solve for realistic numbers of users and subcarriers.

This chapter analyzes the maximum performance attainable in broadcast OFDMA channels from the information-theoretic point of view. To do that, we use a novel approach to the resource allocation problems in OFDMA systems by viewing them as optimal control problems. In this framework the control variables are the resources to be assigned to each OFDM subchannel (power, rate and user). Once they are posed as optimal control problems, dynamic programming (DP) (Bertsekas, 2005) is used to obtain the optimal resource allocation. The application of DP leads to iterative algorithms for the computation of the optimal resource allocation. Both continuous and discrete rate allocation problems are addressed and several numerical examples are presented showing the maximum achievable performance of OFDMA in broadcast channels as function of different channel and system parameters.

### 1.1 Review of related works

Resource allocation in OFDMA systems has been an active area of research during the last years and a wide variety of techniques and algorithms have been proposed. The capacity region of general broadband channels was characterized in (Goldsmith & Effros, 2001), where the authors also derived the optimal power allocation achieving the boundary points of the capacity region. In this seminal work, the channel is decomposed into a set of  $N$  parallel independent narrowband subchannels. Each parallel subchannel is assigned to various users, to a single user, or even not assigned to any user. In the first case, the transmitter uses superposition coding (SC) and the corresponding receivers use successive interference cancelation (SIC). If a subchannel is assigned to a single user, an AWGN capacity-achieving code is used. Moreover, a fraction of the total available power is assigned to each user in

each subchannel. Then, taking the limit as  $N$  goes to infinite (continuous frequency variable), the problem can be solved using multilevel water-filling. Similarly, in (Hoo et al., 2004) the authors characterize the asymptotic (when  $N$  goes to infinite) FDMA multiuser capacity region and propose optimal and suboptimal resource allocation algorithms to achieve the points in such region. Here, unlike (Goldsmith & Effros, 2001), each subchannel is assigned to one user at most and a separate AWGN capacity-achieving code is used in each subchannel. In OFDMA systems the number of subchannels is finite. Each subchannel is assigned to one user at most, and a power value is allocated to each subcarrier. OFDMA is a suboptimal scheme in terms of capacity but, due to its orthogonality and feasibility, it is an adequate multiple access scheme for practical systems. Moreover, OFDMA can achieve near capacity performance when the system resources are optimally allocated.

In (Seong et al., 2006) and (Wong & Evans, 2008) efficient resource allocation algorithms are derived to characterize the capacity region of OFDMA downlink channels. The proposed algorithms are based on the dual decomposition method (Yu & Lui, 2006). In (Wong & Evans, 2008) the resource allocation problem is considered for both continuous and discrete rates, as well as for the case of partial channel knowledge at the transmitter. By using the dual decomposition method, the algorithms are asymptotically optimal when the number of subcarriers goes to infinite and is close to optimal for practical numbers of OFDM subcarriers. Some specific points in the rate region are particularly interesting. For example the maximum sum-rate point where the sum of the users' rates is maximum, or the maximum symmetric-rates point where all users have maximum identical rate. Many times, in practical systems one is interested in the maximum achievable performance subject to various QoS (Quality of Service) users' requirements. For example, what is the maximum sum rate maintaining given proportional rates among users, or what is the maximum sum-rate guarantying minimum rate values to a subset of users. All these are specific points in the capacity region that can be achieved with specific resource allocation among the users. A crucial problem here is to determine the optimal resource allocation to achieve such points. Mathematically, these problems are also formulated as optimization problems constrained by the available system resources. In (Jang & Lee, 2003) the authors show the resource allocation strategy to maximize the sum rate of multiuser transmission in broadcast OFDM channels. They show that the maximum sum-rate is achieved when each subcarrier is assigned to the user with the best channel gain for that subcarrier. Then, the transmit power is distributed over the subcarriers by the water-filling policy. In asymmetric channels, the maximum sum-rate point is usually unfair because the resource allocation strategy favors users with good channel, producing quite different users' rates. Looking for fairness among users, (Ree & Cioffi, 2000) derive a resource allocation scheme to maximize the minimum of the users' rates. In (Shen et al., 2005) the objective is to maximize the rates maintaining proportional rates among users. In (Song & Li, 2005) an optimization framework based on utility-function is proposed to trade off fairness and efficiency. In (Tao et al., 2008), the authors maximize the sum rate guarantying fixed rates for a subset of users.

## 2. Channel and system model

Fig. 1 shows a block diagram of a single-user OFDM system with  $N$  subcarriers employing power and rate adaptation. It comprises three main elements: the transmitter, the receiver and the resource allocator. The channel is assumed to remain fixed during a block of OFDM symbols. At the beginning of each block the receiver estimates the channel state and sends this information (CSI: Channel state information) to the resource allocator, usually via a

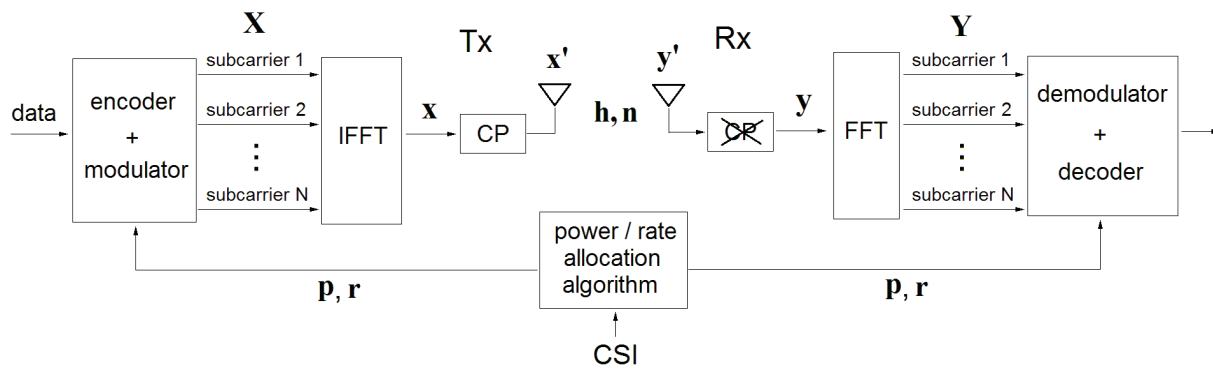

Fig. 1. Single-user OFDM system with power and rate adaptation.

feedback channel. The resource allocator can be physically embedded with the transmitter or the receiver. From the CSI, the resource allocation algorithm computes the data rate and transmit power to be transmitted through each subcarrier. Let vectors  $\mathbf{r} = [r_1 r_2 \dots r_N]^T$  and  $\mathbf{p} = [p_1 p_2 \dots p_N]^T$  denote the data rates and transmit powers allocated to the OFDM subchannels, respectively. This information is sent to the transmit encoder/modulator block, which encodes the input data according to  $\mathbf{r}$  and  $\mathbf{p}$ , and produces the streams of encoded symbols to be transmitted through the different subchannels. It is well known that coding across the subcarriers does not improve the capacity (Tse & Viswanath, 2005) so, from an information-theoretic point of view, the maximum performance is achieved by using independent coding strategies for each OFDM subchannel. To generate an OFDM symbol, the transmitter picks one symbol from each subcarrier stream to form the symbols vector  $\mathbf{X} = [X[1], X[2], \dots, X[N]]^T$ . Then, it performs an inverse fast Fourier transform (IFFT) operation on  $\mathbf{X}$  yielding the vector  $\mathbf{x}$ . Finally the OFDM symbol  $\mathbf{x}'$  is obtained by appending a cyclic prefix (CP) of length  $L_{cp}$  to  $\mathbf{x}$ . The receiver sees a vector of symbols  $\mathbf{y}'$  that comprises the OFDM symbol convolved with the base-band equivalent discrete channel response  $\mathbf{h}$  of length  $L$ , plus noise samples

$$\mathbf{y}' = \mathbf{h} * \mathbf{x}' + \mathbf{n}. \quad (1)$$

It is assumed that the noise samples at the receiver ( $\mathbf{n}$ ) are realizations of a ZMCSCG (zero-mean circularly-symmetric complex Gaussian) random variables with variance  $\sigma^2$ :  $\mathbf{n} \sim CN(\mathbf{0}, \sigma^2 \mathbf{I})$ . The receiver strips off the CP and performs a fast Fourier transform (FFT) on the sequence  $\mathbf{y}$  to yield  $\mathbf{Y}$ . If  $L_{cp} \geq L$ , it can be shown that

$$Y_k = H_k X_k + N_k, \quad k = 1, \dots, N, \quad (2)$$

where  $\mathbf{H} = [H_1, H_2, \dots, H_N]^T$  is the FFT of  $\mathbf{h}$ , i.e. the channel frequency response for each OFDM subcarrier, and the  $N_k$ 's are samples of independent ZMCSCG variables with variance  $\sigma^2$ . Therefore, OFDM decomposes the broadband channel into  $N$  parallel subchannels with channel responses given by  $\mathbf{H} = [H_1, H_2, \dots, H_N]^T$ . In general the  $H_k$ 's at different subcarriers are different.

Note that the energy of the symbol  $X_k$  is determined by the  $k$ -th entry of the power allocation vector  $p_k$ . It is assumed that the transmitter has a total available transmit power  $P_T$  to be distributed among the subcarriers, so  $\sum_{k=1}^N p_k \leq P_T$ . The coding/modulation employed for the  $k$ -th subchannel is determined by the corresponding entry ( $r_k$ ) of the rate allocation vector  $\mathbf{r}$ .

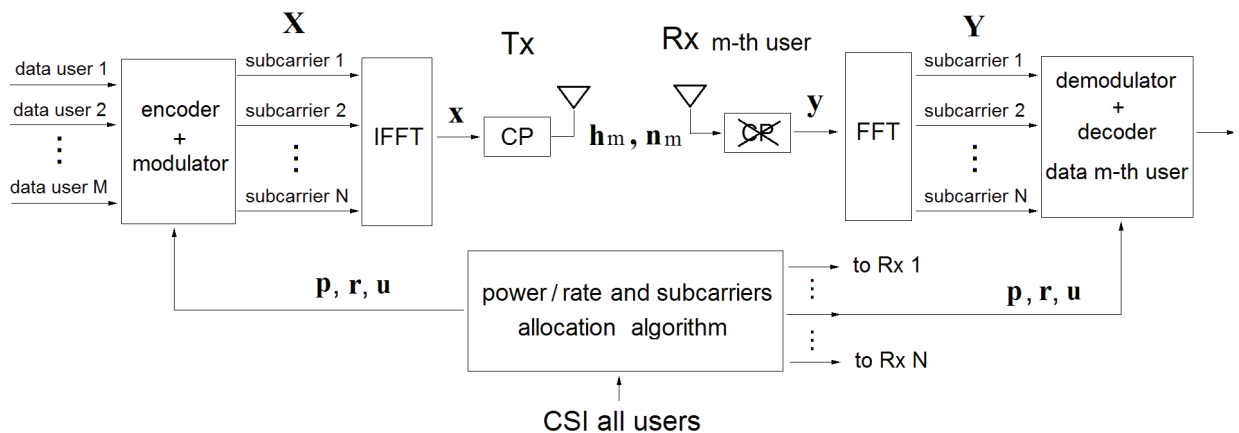

Fig. 2. Multi-user OFDM system with adaptive resources allocation.

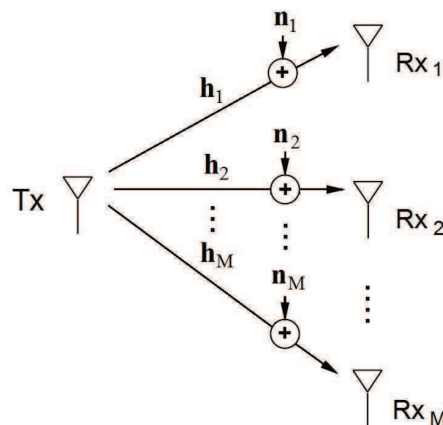

Fig. 3. M-users broadcast broadband channel.

Fig. 2 shows a block diagram of a downlink OFDMA system. It comprises the transmitter, the resource allocator unit and  $M$  users' receivers (Fig. 2 only shows the  $m$ -th receiver). The resource allocator is physically embedded with the transmitter. It is assumed that the transmitter sends independent information to each user. The base-band equivalent discrete channel response of the  $m$ -th user is denoted by  $\mathbf{h}_m = [h_{m,1}h_{m,2} \cdots h_{m,L_m}]^T$ , where now  $L_m$  is the number of channel taps and  $\mathbf{n}_m \sim CN(\mathbf{0}, \sigma_m^2 \mathbf{I})$  are the noise samples at the  $m$ -th receiver. Noise and channels at different receivers are assumed to be independent. A scheme of a  $M$ -user OFDM broadcast channel is depicted in Fig. 3.

Let  $\mathbf{H}_m = [H_{m,1}H_{m,2} \cdots H_{m,N}]^T$  denote the complex-valued frequency-domain channel response of the OFDM channel, as seen by the  $m$ -th user, for the  $N$  subchannels. As it was mentioned,  $\mathbf{H}_m$  is the  $N$ -points discrete-time Fourier transform (DFT) of  $\mathbf{h}_m$ .

It is assumed that the multi-user channel remains constant during the transmission of a block of OFDM symbols. At the beginning of each block each receiver estimates its channel response for each subcarrier, and informs the resource allocator by means of a feedback channel. Then, it computes the resource allocation vectors  $\mathbf{r}, \mathbf{p}$  and  $\mathbf{u} = [u_1u_2 \dots u_N]^T$ , where  $u_k$  denotes the user assigned to the  $k$ -th subcarrier. Each subcarrier is assigned to a single user, so it is assumed that subcarriers are not shared by different users. Note that, since  $u_k \in S_u = \{1, 2, \dots, M\}$ , there are  $M^N$  possible values of  $\mathbf{u}$ , so  $M^N$  different ways to assign the subcarriers to the users. Once these vectors have been computed, the resource allocator

informs the transmitter and receivers through control channels. Then, the transmitter encode the input data according to the resource allocation vectors and stores the stream of encoded symbols to be transmitted through the OFDM subchannels. The OFDM symbols are created and transmitted as in the single-user case. Each user receives and decodes its data from the assigned subchannels (given by  $\mathbf{u}$ ).

Let  $\gamma$  be a  $M \times N$  matrix whose entries are the channel power gains for the different users and subcarriers normalized to the corresponding noise variance

$$\gamma_{m,k} = \frac{|H_{m,k}|^2}{\sigma_m^2}. \quad (3)$$

Assuming a continuous codebook available at the transmitter,  $r_k$  can take any value subject to the available power and the channel condition. The maximum attainable rate through the  $k$ -th subchannel is given by

$$r_k = \log_2(1 + p_k \gamma_{u_k,k}) \quad \text{bits/OFDM symbol}, \quad (4)$$

where  $p_k$  is the power assigned to the  $k$ -th subchannel. The minimum needed power to support a given data rate  $r_k$  through the  $k$ -subcarrier will be

$$p_k = \frac{2^{r_k} - 1}{\gamma_{u_k,k}}. \quad (5)$$

We assume that the system always uses the minimum needed power to support a given rate so, for a fixed subcarriers-to-users allocation  $\mathbf{u}$ , the  $r_k$ 's and the  $p_k$ 's are interchangeable in the sense that a given rate determines the needed transmit power and viceversa.

In practical systems there is always a finite codebook, so the data rate at each subchannel is constrained to take values from a discrete set  $r_k \in S_r = \{r^{(1)}, r^{(2)}, \dots, r^{(N_r)}\}$  where each value corresponds to a specific modulation and code from the available codebook. The transmit rates and powers are related by

$$r_k = \log_2(1 + \beta(r_k) p_k \gamma_{u_k,k}) \quad \text{bits/OFDM symbol}, \quad (6)$$

where the so-called SNR-gap approximation is adopted Cioffi et al. (1995), being  $0 < \beta(r) \leq 1$  the SNR gap for the corresponding code (with rate  $r$ ). For a given code  $\beta(r)$  depends on a pre-fixed targeted maximum bit-error rate. Then, the SNR-gap can be interpreted as the penalty in terms of SNR due to the use of a realistic modulation/coding scheme. There will be a SNR gap  $\beta(r^{(i)})$ ,  $i = 1, \dots, N_r$  associated with each code of the codebook for a given targeted bit-error rate. The minimum needed power to support  $r_k$  will be

$$p_k = \frac{2^{r_k} - 1}{\beta(r_k) \gamma_{u_k,k}}. \quad (7)$$

Since there is a finite number of available data rates, there will be a finite number of possible rate allocation vectors  $\mathbf{r}$ . Note that there are  $(N_r)^N$  possible values of  $\mathbf{r}$ , but, in general, for a given  $\mathbf{u}$  only some of them will fulfil the power constraint.

### 3. The rate region of OFDMA

For a given subcarriers-to-users and rates-to-subcarriers allocation vectors  $\mathbf{u}$  and  $\mathbf{r}$ , the total rate received by the  $m$ -th user will be given by

$$R_m(\mathbf{r}, \mathbf{u}) = \sum_{k=1}^N \delta_{m,u_k} r_k \quad \text{bits/OFDM symbol}, \quad (8)$$

where  $\delta_{i,j}$  is the Kronecker delta. The users' rates are grouped in the corresponding rate vector

$$\mathbf{R}(\mathbf{r}, \mathbf{u}) = [R_1(\mathbf{r}, \mathbf{u}), R_2(\mathbf{r}, \mathbf{u}), \dots, R_M(\mathbf{r}, \mathbf{u})]^T, \quad (9)$$

which is the point in the rate region associated with the resource allocation vectors  $\mathbf{r}$  and  $\mathbf{u}$ . Let  $\mathcal{R}_0$  denote the points achieved for all possible combinations of  $\mathbf{u}$  and  $\mathbf{r}$

$$\mathcal{R}_0 = \bigcup_{\mathbf{r} \in S_{\mathbf{r}}, \mathbf{u} \in S_{\mathbf{u}}} \mathbf{R}(\mathbf{r}, \mathbf{u}), \quad (10)$$

where  $S_{\mathbf{r}}$  and  $S_{\mathbf{u}}$  are the set of all possible rates-to-subcarriers and subcarriers-to-users allocation vectors, respectively. Therefore,  $\mathcal{R}_0$  comprises the rate vectors associated with single resource allocation strategies given by  $\mathbf{u}$  and  $\mathbf{r}$ . Later, it will be shown that, in general,  $\mathcal{R}_0$  is not a convex region. Let  $(\mathbf{r}_1, \mathbf{u}_1)$  and  $(\mathbf{r}_2, \mathbf{u}_2)$  be two possible resource allocations that achieves the points  $\mathbf{R}_1 = \mathbf{R}(\mathbf{r}_1, \mathbf{u}_1)$  and  $\mathbf{R}_2 = \mathbf{R}(\mathbf{r}_2, \mathbf{u}_2)$  in  $\mathcal{R}_0$ . By time-sharing between the two resource allocation strategies, all points in the segment  $\mathbf{R}_1$ - $\mathbf{R}_2$  can be achieved. Therefore, the rate region of OFDMA will be the convex hull of  $\mathcal{R}_0$ :  $\mathcal{R} = H(\mathcal{R}_0)$ . Note that the achievement of any point of  $\mathcal{R}$  not included in  $\mathcal{R}_0$  requires time-sharing among different resource allocation schemes.

The next two subsections analyze the OFDMA rate region for the cases of continuous and discrete rates. Mathematical optimization problems for the computation of the rate region are posed, and their solution by means of the DP algorithm is presented.

#### 3.1 Continuous rates

Let us first consider the achievable rate region  $\mathcal{R}_0(\mathbf{u})$  for a fixed subcarriers-to-users allocation vector  $\mathbf{u}$ . It will be the union of the points achieved for all possible rates-to-subcarriers allocation vectors  $\mathbf{r}$

$$\mathcal{R}_0(\mathbf{u}) = \bigcup_{\mathbf{r} \in S_{\mathbf{r}}} \mathbf{R}(\mathbf{r}, \mathbf{u}). \quad (11)$$

It can be shown that  $\mathcal{R}_0(\mathbf{u})$  is a convex region (Cover & Thomas, 1991), being its boundary points the solution of the following convex optimization problems

$$\begin{aligned} & \underset{\mathbf{r}}{\text{maximize}} && \boldsymbol{\lambda}^T \mathbf{R}(\mathbf{u}) = \sum_{k=1}^N \lambda_{u_k} r_k \\ & \text{subject to} && \sum_{k=1}^N (2^{r_k} - 1) / \gamma_{u_k, k} \leq P_T \\ & && r_k \in S_{\mathbf{r}}, \quad k = 1, \dots, N, \end{aligned} \quad (12)$$

for different values of vector  $\boldsymbol{\lambda} = [\lambda_1 \lambda_2 \dots \lambda_M]^T$ , where  $\lambda_m \geq 0$ .  $\boldsymbol{\lambda}$  can be geometrically interpreted as the orthogonal vector to the hyperplane tangent to the achievable rate region at a point in the boundary. The components of  $\boldsymbol{\lambda}$  are usually denoted as users' priorities. Note the constraint regarding the total available power. This is a well-known convex problem (Boyd & Vandenberghe, 2004) whose solution can be expressed in closed-form as follows



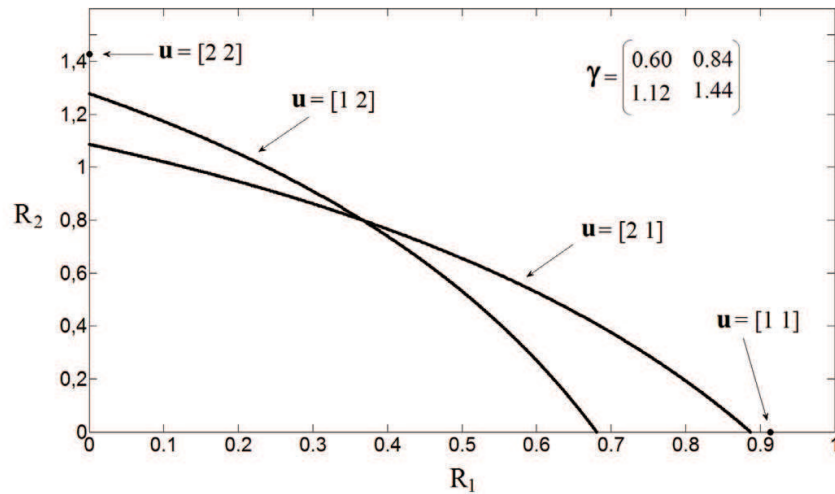

Fig. 4. Rate regions of all vectors  $\mathbf{u}$ . The total transmit power is  $P_T = 1$ .

$$r_k^* = \begin{cases} \log_2 \left( \frac{\lambda_{u_k} \gamma_{u_k, k}}{\mu} \right) & \text{if } \mu \leq \lambda_{u_k} \gamma_{u_k, k} \\ 0 & \text{if } \mu \geq \lambda_{u_k} \gamma_{u_k, k} \end{cases} \quad (13)$$

where  $\mu$  is a Lagrangian parameter which can be implicitly obtained from

$$\sum_{k=1}^N \left( \frac{\lambda_{u_k}}{\mu} - \frac{1}{\gamma_{u_k, k}} \right)^+ = P_T, \quad (14)$$

where  $(a)^+ = \max\{a, 0\}$ .

Fig. 4 shows the rate regions  $\mathcal{R}(\mathbf{u})$  for all possible subcarriers-to-users allocation vectors ( $\mathbf{u}$ ) in a toy example with  $M = 2$  users,  $N = 2$  subcarriers and  $P_T = 1$ . (Although it is not a realistic channel, it is used here to illustrate the resource allocation problem in OFDMA channels). Here and in the following results, the rates are given in bits/OFDM symbol.

When the system allocates all subcarriers to a single user ( $u_k = u, \forall k$ ), the broadcast channel turns into a single-user channel and the solution of (12) does not depend on  $\lambda$ . Therefore, in these cases the rate region degenerates in a single point on the corresponding axis. The rate at this point is the capacity of the corresponding single-user OFDM channel. Once the optimal rate vector  $\mathbf{r}^*$  is obtained, the power to be allocated to each subcarrier is given by (5).

The achievable points for all possible values of  $\mathbf{u}$  and  $\mathbf{r}$  will be

$$\mathcal{R}_0 = \bigcup_{\mathbf{u} \in \mathcal{S}_{\mathbf{u}}} \mathcal{R}_0(\mathbf{u}). \quad (15)$$

In general,  $\mathcal{R}_0$  is not convex. This fact can be observed in the example of Fig. 4. The rate region of the OFDMA broadcast channel is the convex hull of  $\mathcal{R}_0$ :  $\mathcal{R} = H(\mathcal{R}_0)$ . The rate region for the example of Fig. 4 is depicted in Fig. 5 as the convex hull of the region achieved by all vectors  $\mathbf{u}$ . In general, there are subcarriers-to-users allocation vectors  $\mathbf{u}$  that are never optimal. This is the case of  $\mathbf{u} = [1, 2]^T$  in the example.

As it was mentioned, there are  $M^N$  possible subcarriers-to-users allocation vectors  $\mathbf{u}$ . Therefore, an exhaustive search among all the possible vectors requires the computation of

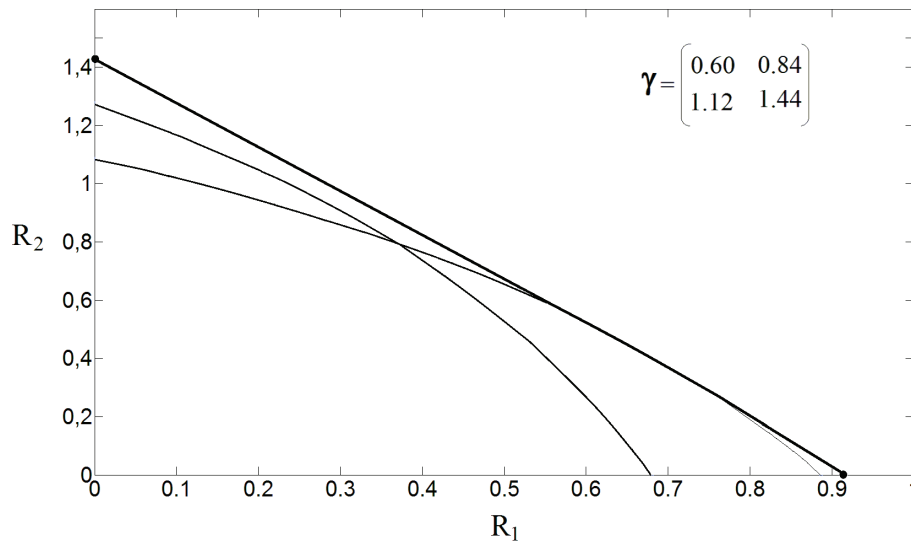

Fig. 5. OFDMA rate region. It is the convex hull of the rate regions achieved for all vectors  $\mathbf{u}$  (see Fig. 4).

$M^N$  waterfilling solutions for each vector  $\lambda$ , which is not feasible for practical values of  $N$  and  $M$ . An alternative is to jointly optimize over  $\mathbf{u}$  and  $\mathbf{p}$  simultaneously, so the problem becomes

$$\begin{aligned}
 & \underset{\mathbf{r}, \mathbf{u}}{\text{maximize}} && \lambda^T \mathbf{R}(\mathbf{r}, \mathbf{u}) = \sum_{k=1}^N \lambda_{u_k} r_k \\
 & \text{subject to} && \sum_{k=1}^N (2^{r_k} - 1) / \gamma_{u_k, k} \leq P_T \\
 & && u_k \in S_{\mathbf{u}}, \quad k = 1, \dots, N \\
 & && r_k \in S_{\mathbf{r}}, \quad k = 1, \dots, N
 \end{aligned} \tag{16}$$

This is a mixed non-linear constrained optimization problem. In general these kind of problems are difficult to solve. However, it has the structure of a DP problem with the following elements (see appendix: Dynamic Programming):

- The process stages are the subchannels, so the number of stages is  $N$ ,
- Control vector:  $\mathbf{c}_k = [u_k, r_k]^T$ ,
- State variable:  $x_k = \sum_{i=1}^{k-1} (2^{r_i} - 1) / \gamma_{u_i, i}$ ,
- Initial state  $x_1 = 0$ ,
- Subsets of possible states:  $0 \leq x_k \leq P_T$ ,
- Subsets of admissible controls:

$$C_k(x_k) = \left\{ [u_k, r_k]^T \mid u_k \in S_{\mathbf{u}}, \quad r_k \in S_{\mathbf{r}}, \quad r_k \leq \log_2(1 + (P_T - x_k) \gamma_{u_k, k}) \right\},$$

- System equation:  $x_{k+1} = f_k(x_k, c_k) = x_k + (2^{r_k} - 1) / \gamma_{u_k, k}$ ,
- Cost functions:  $g_k(c_k) = \lambda_{u_k} r_k$ .

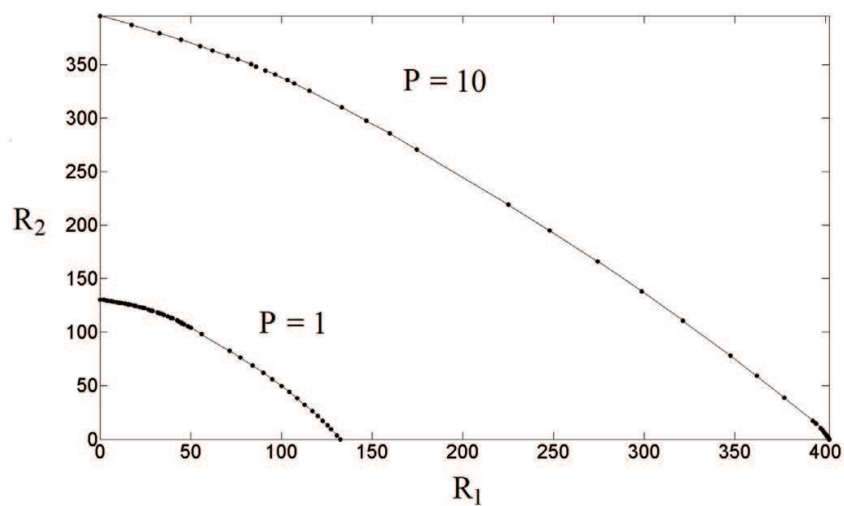

Fig. 6. Rate regions for the two-users channel of Fig. 7 considering different values of average transmit power per subchannel ( $P$ ).

The entries of the control vector  $\mathbf{c}_k$  are the user and the rate allocated to the  $k$ -th subchannel, that take values from the sets  $S_{\mathbf{u}}$  and  $S_r$ , respectively. The state variable  $x_k$  is the accumulated power transmitted in the previous subchannels. Therefore  $0 \leq x_k \leq P_T$ , and the initial state is  $x_1 = 0$ . The control component  $r_k$  is constrained by the available power at the  $k$ -th stage:  $P_T - x_k$ . Note that the solutions of (16) for different  $\lambda$ 's are the points of  $\mathcal{R}_0$  located in the boundary of the rate region, and the convex hull of these points are the boundary of the rate region.

By using the DP algorithm, rate regions for a more realistic two user channel have been computed. They are depicted in Fig. 6. In this example the number of subcarriers is  $N = 128$  and the users' subchannel responses are shown in Fig. 7. They are normalized so the average gain (averaging over the subchannels and users) equals 1. These channel realizations have been obtained from a broadband Rayleigh channel model with  $L = 16$  taps and an exponential power delay profile with decay factor  $\rho = 0.4$ . This channel model will be described in section 5. The noise variances are assumed to be  $\sigma_m^2 = 1$ , identical for all users. Fig. 6 shows the rate region for two different values of average power per subchannel:  $P = P_T/N = 1$  and  $P = P_T/N = 10$ . Note that if the OFDM subchannels were identical (frequency-flat broadband channel), the average SNR at the OFDM subchannels would be 0dB and 10dB, respectively.

To obtain the rate regions of Fig.6, (16) has to be solved for each  $\lambda$  by using the DP algorithm. In each case, the solution is a pair of optimal resource allocation vectors  $\mathbf{u}^*$  and  $\mathbf{r}^*$ . Then, the power to be transmitted through the subchannels  $\mathbf{p}^*$  is given by (5). The corresponding users' rate vector are obtained from (8) and shown in Fig. 6 as a marker point in the boundary of the rate region. Therefore, the marker points are the points of  $\mathcal{R}_0$  located in the boundary of the rate region and associated with pairs of resource allocation vectors  $(\mathbf{u}, \mathbf{r})$  which are solutions of (16) for different users' priority vectors. For example, for  $\lambda = [0.4, 0.6]^T$  and  $P_T = 10$  the optimal resource allocation vectors are shown in Fig. 8, as well as the transmit power through the OFDM subchannels ( $\mathbf{p}^*$ ). The resulting users' rates are  $\mathbf{R}(\mathbf{u}^*, \mathbf{p}^*) = [82.7, 350.7]^T$ .

Note that different vectors  $\lambda$  can lead to identical solution of (16), and hence to identical points/markers in the boundary of the rate region. The convex hull of the marker points

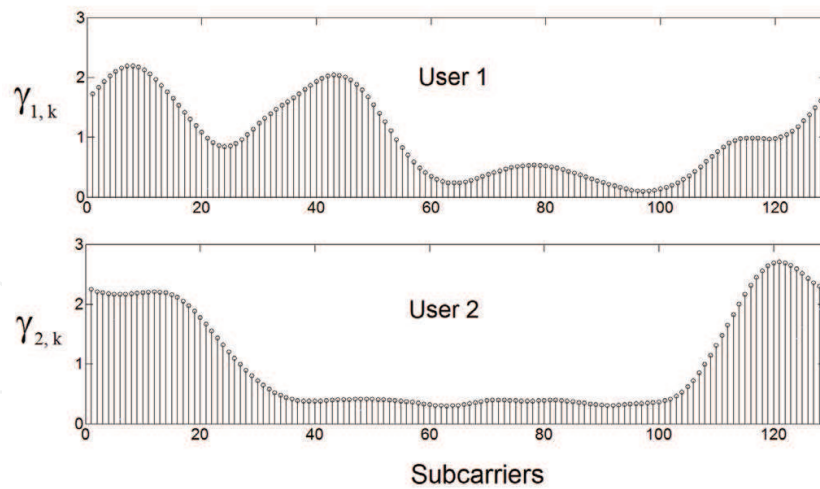

Fig. 7. Normalized subchannel gains at the OFDM subchannels.

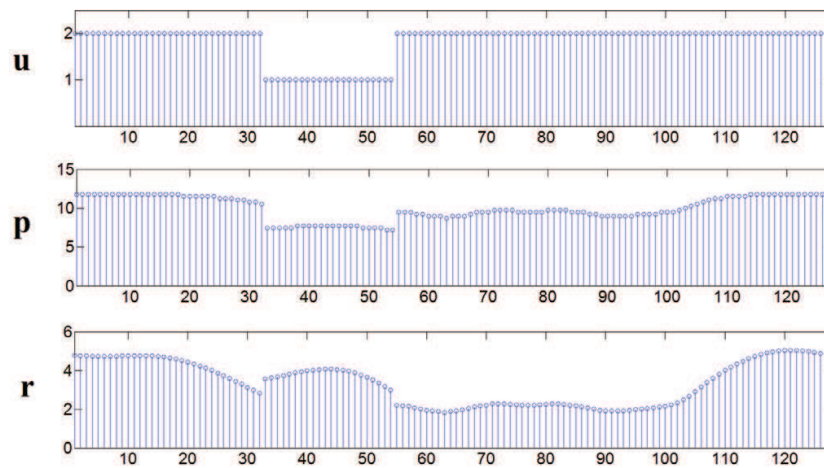

Fig. 8. Optimal resource allocation vectors  $\mathbf{u}$  and  $\mathbf{r}$  for  $\lambda = [0.4, 0.6]^T$  and  $P_T = 10N$ . The figure also shows the resulting power allocation vector  $\mathbf{p}$ .

constitutes the boundary of the rate region. Any point in the segments between two markers is achieved by time sharing between the corresponding optimal resource allocations.

The application of the DP algorithm requires the control and state spaces to be discrete. Therefore, if they are continuous, they must be discretized by replacing the continuous spaces by discrete ones. Once the discretization is done, the DP algorithm is executed to yield the optimal control sequence for the discrete approximating problem. Hence, it becomes necessary to study the effect of discretization on the optimality of the solution. In the problem (16), the state variable  $x_k$  and the second component of the control vector ( $r_k$ ) are continuous. To obtain the rate regions of Fig. 6,  $S_r$  was uniformly discretized considering  $N_d = 2000$  possible rate values between 0 and a maximum rate which is achieved when the total power  $P_T$  is assigned to the best subchannel of all users. The state variable  $x_k$  was discretized in  $N_d$  possible values accordingly. To study the effect of discretization of  $x_k$  and  $r_k$  the rate regions for different values of  $N_d$  are shown in Fig. 9. The channels and simulation parameters were as in Fig. 6. It shows that the required  $N_d$  is less than 500.

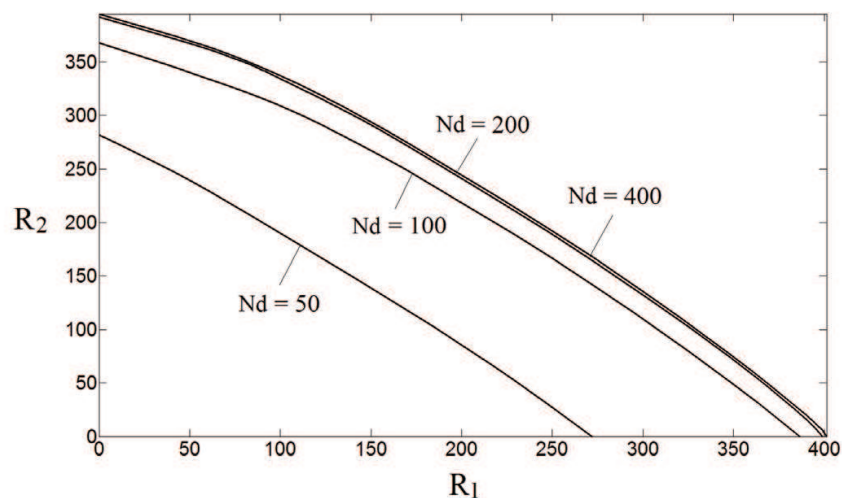

Fig. 9. Rate regions for different number of rate discretization values  $N_d$

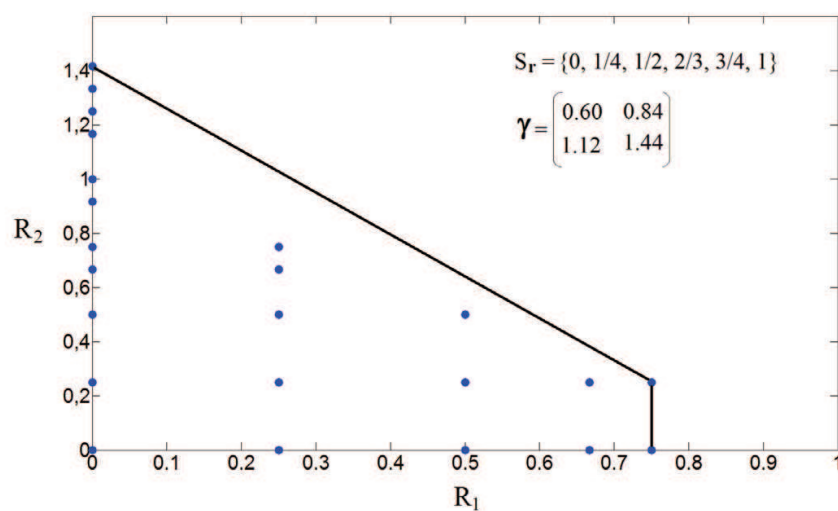

Fig. 10. Example of OFDMA rate region with discrete codebook  $S_r$ .

### 3.2 Discrete rates

Now,  $S_r$  is a finite set and therefore the set of achievable points  $\mathcal{R}_0$  is finite. It comprises all points resulting from the combinations of  $\mathbf{r}$  and  $\mathbf{u}$  that fulfill the power constraint. Therefore, the cardinality of  $\mathcal{R}_0$  depends on  $\gamma$ ,  $S_r$  and  $P_T$ .

As an example, let us consider again the channel example of Fig. 4 and 5 with  $P_T = 1$  and a codebook with the following available rates  $S_r = \{0, 1/4, 1/2, 2/3, 3/4, 1\}$ . Note that by including zero rate in  $S_r$  we consider the possibility of no transmission through some subchannels. All achievable rate vectors ( $\mathcal{R}_0$ ), and their convex hull, are shown in Fig. 10, where  $\beta(r) = 1, \forall r \in S_r$  is assumed.

The set  $\mathcal{R}_0$  can be viewed as the union of the points achieved by different vectors  $\mathbf{u} \in S_u$ :  $\mathcal{R}_0(\mathbf{u})$ . For example, in Fig. 11 the points achieved by  $\mathbf{u} = [1, 2]^T$  are highlighted, as well as their convex hull. It can be observed that, for this particular value of  $\mathbf{u}$  the attainable rate vectors are always under the convex hull of  $\mathcal{R}_0$ . Therefore,  $\mathbf{u} = [1, 2]$  is not the optimal subcarriers-to-users allocation vector in any case.

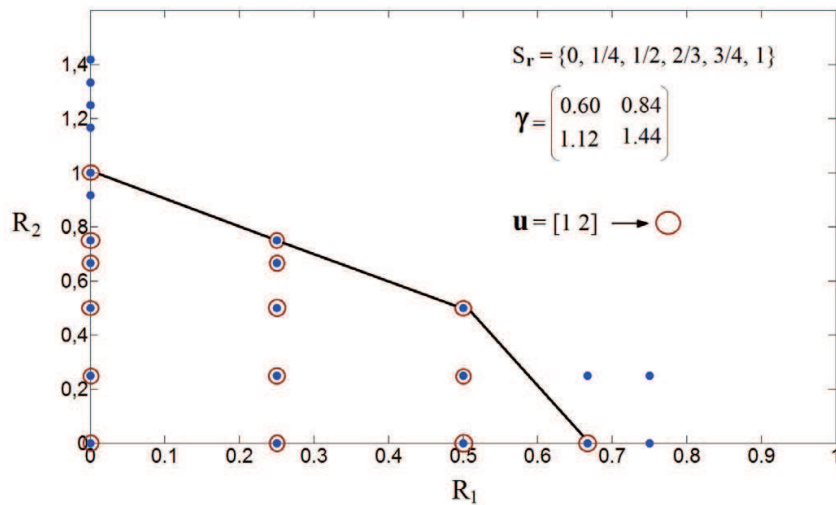

Fig. 11. Achievable points for  $\mathbf{u} = [1, 2]$ , and their convex hull.

In general the vertex points in the boundary of  $\mathcal{R}_0(\mathbf{u})$  will be the solutions of (12), but now  $S_r$  is a finite set. Therefore, both the state and control variables are discrete so (12) is a fully integer optimization problem. Unlike the continuous rates case, there is not closed-form solution when the allowed rates belong to a discrete set. The problem can be formulated as a DP problem where

- The process stages are the subchannels, so the number of stages is  $N$ ,
- Control variable:  $\mathbf{c}_k = r_k$ ,
- State variable:  $x_k = \sum_{i=1}^{k-1} (2^{r_i} - 1) / \gamma_{u_i, i}$ ,  $0 \leq x_k \leq P_T$ ,  $x_1 = 0$ ,  $x_{N+1} = P_T$
- Initial state  $x_1 = 0$
- Subsets of possible states:  $0 \leq x_k \leq P_T$
- Subsets of admissible controls:  $C_k(x_k) = \{r_k | r_k \in S_r, r_k \leq \log_2(1 + (P_T - x_k)\gamma_{u_k, k})\}$ ,
- System equation:  $x_{k+1} = f_k(x_k, c_k) = x_k + (2^{r_k} - 1) / \gamma_{u_k, k}$ ,
- Cost functions:  $g_k(c_k) = \lambda_{u_k} r_k$ .

The control variables  $\mathbf{c}_k$  are the rates allocated to the subchannels, that take values from the set  $S_r$ . The state variable  $x_k$  is the accumulated power transmitted in the previous subchannels (up to  $k - 1$ -th subchannel). Therefore  $0 \leq x_k \leq P_T$ , and the initial state is  $x_1 = 0$ . The control component  $r_k$  is constrained by the available power at the  $k$ -th stage:  $P_T - x_k$ .

Since there are  $M^N$  possible values of  $\mathbf{u}$ , an exhaustive search among all possible vectors  $\mathbf{u}$  requires to solve the above DP problem  $M^N$  times for each vector  $\lambda$ , which is not feasible for practical values of  $M$  and  $N$ . In this case one has to jointly optimize over  $\mathbf{u}$  and  $\mathbf{r}$  simultaneously, as in (16). Now, unlike the continuous rates case, (16) is an integer programming problem because the control variable  $c_k$  is fully discrete taking values from a finite set  $S_u \times S_r$ .

Fig. 12 shows the rate regions for the two user channel of Fig. 7 considering continuous and discrete rate allocation. As it is expected, continuous rate adaptation always outperforms the discrete rate case. In all cases the rate region has been obtained from the DP algorithm. The figure depicts the rate region for two different values of average power per subcarrier:  $P = 1$  and  $P = 10$ . It is also assumed that the noise at the OFDM subchannels are

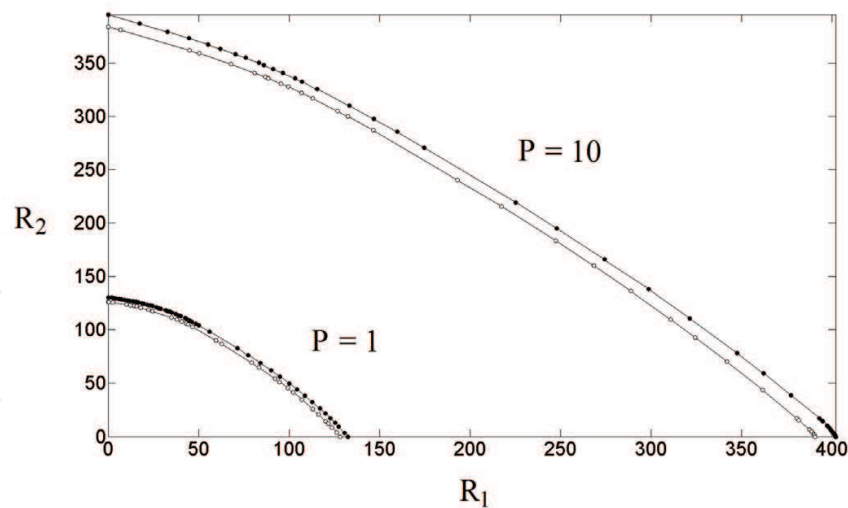

Fig. 12. Rate regions for the two user channel of Fig. 7 considering continuous and discrete rate allocation.  $P$  denotes the average transmit power per subchannel

i.i.d. with variance  $\sigma_m^2 = 1$ , identical for all users. Then, if the subchannels were identical and frequency-flat, the average SNR at the OFDM subchannels would be 0dB and 10dB, respectively. Now, the following set of available rates have been considered:  $S_r = \{0, 1/2, 3/4, 1, 3/2, 2, 3, 4, 9/2\}$ . These are the data rates of a set of rate-compatible punctured convolutional (RCPC) codes, combined with M-QAM modulations, that are used in the 802.11a (<http://grouper.ieee.org/groups/802/11/>). The advantage of RCPC codes is to have a single encoder and decoder whose error correction capabilities can be modified by not transmitting certain coded bits (puncturing). Therefore, the same encoder and decoder are used for all codes of the RCPC codebook. This makes the RCPC codes, combined with adaptive modulation, a feasible rate adaptation scheme in wireless communications. Apart from the 802.11, punctured codes are used in other standards like WIMAX (<http://www.ieee802.org/16/>, 2011).

To obtain the rate regions of Fig. 12, the maximization problem (16) has been solved, using the DP algorithm, for each  $\lambda$ . In each case, the solution is a pair of optimal resource allocation vectors  $\mathbf{u}^*$  and  $\mathbf{r}^*$ . Now, the corresponding users' rate vector is obtained from (8) and shown in 12 as a marker point in the boundary of the rate region. For example, for  $\lambda = [0.4, 0.6]^T$  and  $P_T = 10$  the optimal resource allocation vectors are shown in Fig. 13, as well as the transmit power assigned to each OFDM subchannel ( $\mathbf{p}$ ). These vectors produces the users' rate vector  $\mathbf{R}(\mathbf{u}^*, \mathbf{r}^*) = [89.5, 340.0]^T$ . Note that this is quite similar to the users' rate vector attained for this  $\lambda$  in the continuous rate case. Comparing 8 and 13 one can observe that the resource allocation vectors are similar in the cases of continuous and discrete rates. In fact, for this particular case, the subcarriers-to-users allocation vectors  $\mathbf{u}$  are identical and the rates-to-subcarriers allocation vectors  $\mathbf{r}$  are quite similar. Similar behavior is observed for any other vector  $\lambda$ .

#### 4. Maximum sum-rate

In the case of continuous rate adaptation, the maximum sum rate will be the solution of (16) for  $\lambda = \mathbf{1}_M$ . But, it was shown in (Jang & Lee, 2003) that the sum-rate is maximized when each subcarrier is assigned to the user with the best channel

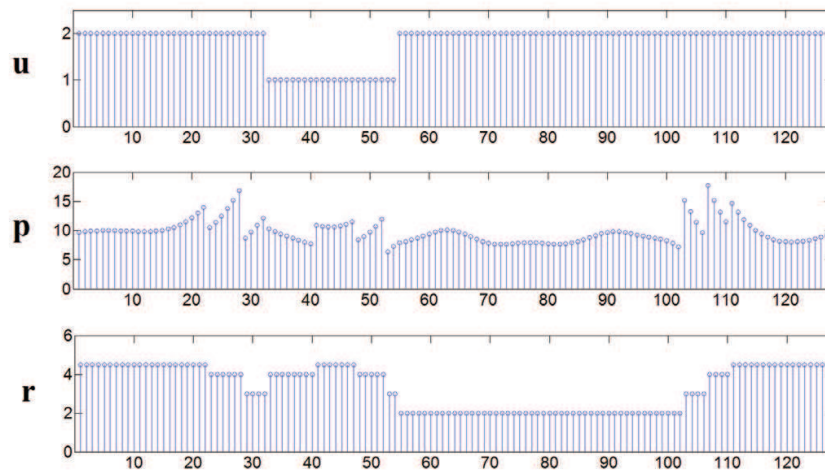

Fig. 13. Optimal resource allocation vectors  $\mathbf{u}$  and  $\mathbf{r}$  for  $\lambda = [0.4, 0.6]^T$  and  $P_T = 10N$ . The figure also shows the power transmitted through the OFDM subchannels  $\mathbf{p}$

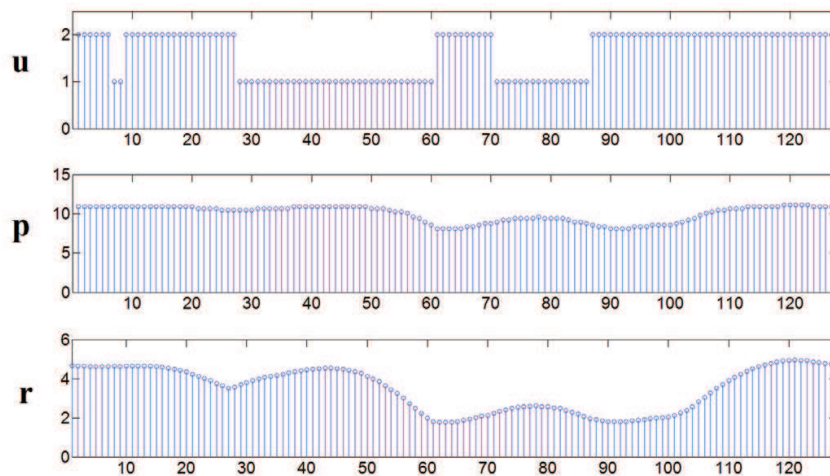

Fig. 14. Optimal resource allocation vectors  $\mathbf{u}$  and  $\mathbf{r}$  to achieve the maximum sum-rate. The total transmit power is  $P_T = 10N$ . The figure also shows the power allocation vector  $\mathbf{p}$

$$u_k^* = \arg \max_m \{ \gamma_{m,k} \}, \quad k = 1, \dots, N, \tag{17}$$

Then, the optimal rates can be calculated from (13) and (14) with  $\lambda = \mathbf{1}_M$ , and the power allocated to each subcarrier is given by (5).

The maximum sum-rate point is always in the boundary of the rate region. In the channel of Figs. 4 and 5, the maximum sum rate is 1.43, which is achieved by  $\mathbf{u}^* = [2, 2]^T$  and  $\mathbf{r}^* = [0.53, 0.90]^T$ . The power allocation is  $\mathbf{p}^* = [0.40, 0.60]^T$ . In this particular case the maximum sum-rate is achieved by allocating all the system resources to the user 2, so the rate for user 1 is zero. In the two-users channel of Fig. 7, the maximum sum rate, for  $P = 10$ , is 445.64. This is achieved by the resource allocation vectors depicted in Fig. 14.

In the case of discrete rate adaptation, the maximum sum rate is also achieved by allocating each subcarrier to the user with the best channel on it. But now, the rates allocated to the subchannels will be the solution of (12) with  $\mathbf{u}$  given by (17). So, the optimal rate allocation



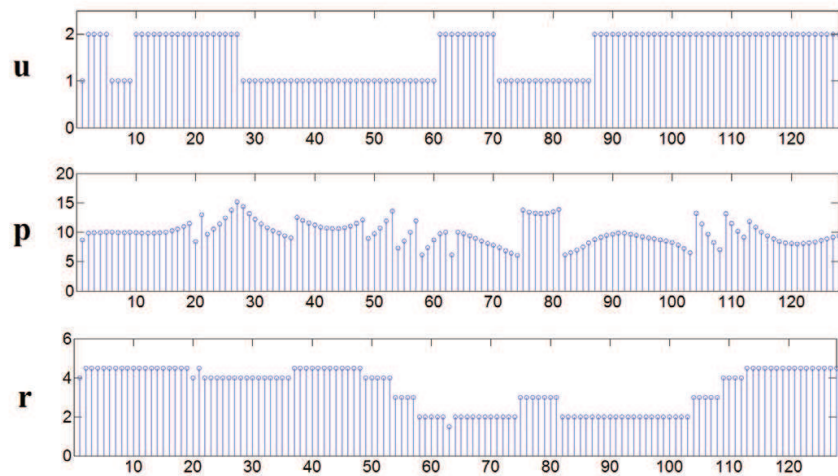

Fig. 15. Optimal resource allocation vectors  $\mathbf{u}$  and  $\mathbf{r}$  to achieve the maximum sum-rate. The total transmit power is  $P_T = 10N$ . The figure also shows the power allocation vector  $\mathbf{p}$

can also be obtained from the DP algorithm. In the simple case of Fig. 10, the maximum sum rate is 1.417, which is achieved by  $\mathbf{u}^* = [2, 2]^T$ ,  $\mathbf{r}^* = [2/3, 3/4]^T$  and  $\mathbf{p}^* = [0.52, 0.47]^T$ . Like in continuous rate adaptation, the maximum sum-rate point is always in the boundary of the rate region. In the two-user channel of Fig. 7, the maximum sum rate is 441.0 assuming that the average transmit power per subcarrier is  $P = 10$  and the set of available rates is  $S_r = \{0, 1/2, 3/4, 1, 3/2, 2, 3, 4, 9/2\}$ . It is achieved by the resource allocation vectors depicted in Fig. 15. Again, the maximum sum-rate and the corresponding resource allocation vectors are quite similar to the continuous rate case.

## 5. Outage rate region

The previous results show the achievable performance (rate vectors) for specific channel realizations. However, due to the intrinsic randomness of the wireless channel, the channel realizations can be quite different. To study the performance for all channel conditions we resort to the outage rate region concept Lee & Goldsmith (2001). The outage rate region for a given outage probability  $P_{out}$  consists of all rate vectors  $\mathbf{R} = [R_1, R_2, \dots, R_M]^T$  which can be maintained with an outage probability no larger than  $P_{out}$ . Therefore, the outage rate region will depend on the statistical parameters of the broadband channel.

In the following results the so-called broadband Rayleigh channel model is considered. This a widely accepted model for propagation environments where there is not line of sight between the transmitter and receiver. According to this model the time-domain channel response for the  $m$ -th user  $\mathbf{h}_m$  is modeled as an independent zero-mean complex Gaussian random vector  $\mathbf{h}_m \sim CN(\mathbf{0}, \text{diag}(\mathbf{\Gamma}_m))$ , where  $\mathbf{\Gamma}_m = [\Gamma_{m,1}, \Gamma_{m,2}, \dots, \Gamma_{m,L}]^T$  is the channel power delay profile (PDP), which is assumed to decay exponentially

$$\Gamma_{m,l} = E\{h_{m,l}h_{m,l}^*\} = A_m \rho_m^l, \quad l = 1, \dots, L_m, \quad (18)$$

where  $L_m$  is the length of  $\mathbf{h}_m$ ,  $\rho_m$  is the exponential decay factor and  $A_m$  is a normalization factor given by

$$A_m = E_m \frac{1 - \rho_m}{\rho_m(1 - \rho_m^{L_m})}, \quad (19)$$

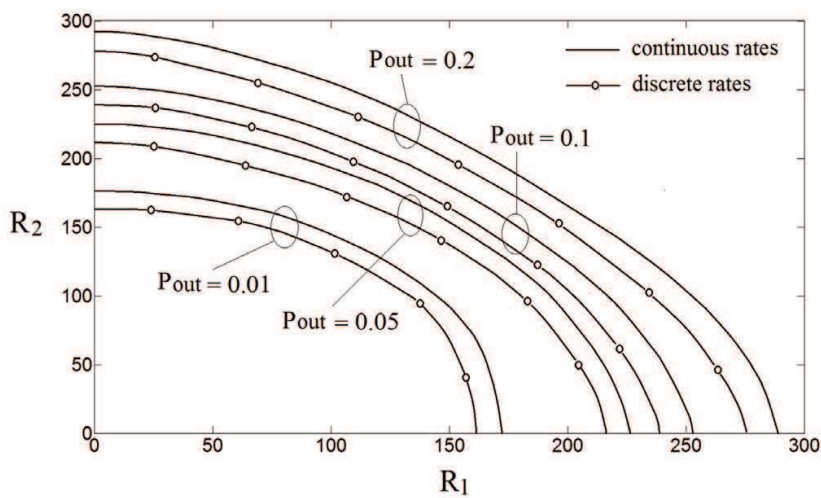

Fig. 16. Outage rate regions for different values of probability of outage  $P_{out}$ .

being  $E_m$  the average energy of the  $m$ -th user channel. Note that the frequency selectivity of the channel is determined by  $\rho_m$ , so the higher the  $\rho_m$  the higher is the frequency selectivity of the  $m$ -th user channel. The exponential decay PDP model is a widely used and it will be assumed in the following results. Any other PDP model could be used. Unless otherwise indicated, the parameters of the following simulations are

- Number of OFDM subcarriers:  $N=128$
- i.i.d. Rayleigh fading channel model with  $\rho = 0.4$ ,  $L = 16$  and  $E = 1$ , for all users
- Available transmit power:  $P_T = 10N$
- Same probability of outage for all users:  $P_{out} = 0.1$
- In the case of discrete rates,  $S_r = \{0, 1/2, 3/4, 1, 3/2, 2, 3, 4, 9/2\}$

To obtain the outage rate region, 5000 channel realizations have been considered in each case. The rate region of each channel realization has been obtained by solving (16) with the DP algorithm.

Fig. 16 shows the outage rate regions for different values of outage probability ( $P_{out}$ ). One can observe the performance gap between continuous and discrete rates, which is nearly constant for different values of  $P_{out}$ . Since the channel is identically distributed for both users, the rate regions are symmetric.

Fig. 17 shows the outage rate regions when the users' channels have different average energy ( $E_m$ ). The sum of the average energy of the channels equals the number of users (2). In this case, only continuous rate adaptation is considered. As it is expected, the user with the best channel gets higher rates.

Fig. 18 shows the two-user outage rate regions for different values of average transmit power per subcarrier  $P = P_T/N$ . Note that the performance gap between continuous and discrete rates increases with  $P$ .

Finally, Fig. 19 compares the outage rate regions for different values of channel frequency selectivity. The figure clearly shows that the higher the frequency selectivity the more useful is the resource adaptation. The gap between continuous and discrete rates does not depend on the frequency selectivity of the channel.

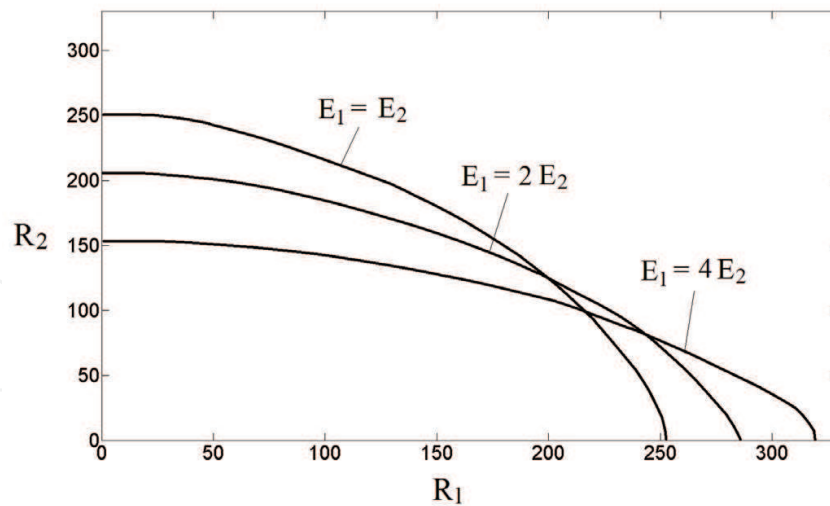

Fig. 17. Outage rate regions when the users' channels have different average energy ( $E_m$ ).

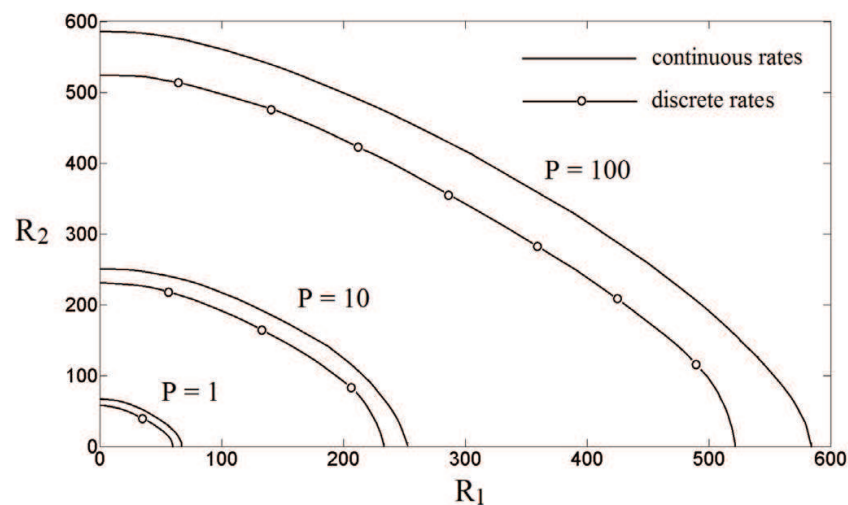

Fig. 18. Outage rate regions for different values of average power per subcarrier  $P$ .

## 6. Conclusions

This chapter analyzes the attainable performance of OFDMA in broadband broadcast channels from an information-theoretic point of view. Assuming channel knowledge at the transmitter, the system performance is maximized by optimally allocating the available system resource among the users. The transmitter has to assign a user, a fraction of the available power and a data rate (modulation and channel coding) to each subchannel. The optimal allocation of these resources leads to non-linear constrained optimization problems which, in general, are quite difficult to solve. These problems are solved by means of a novel approach to the resource allocation problems in OFDMA systems by viewing them as optimal control problems, where the control variables are the resources to be allocated to the OFDM subchannels (power, rate and user). Once the problems are posed as optimal control problems, dynamic programming is used to obtain the optimal resource allocation that maximizes the system performance. This constitutes a new methodology for the computation of optimal resource allocation in OFDMA systems. The achievable performance for given

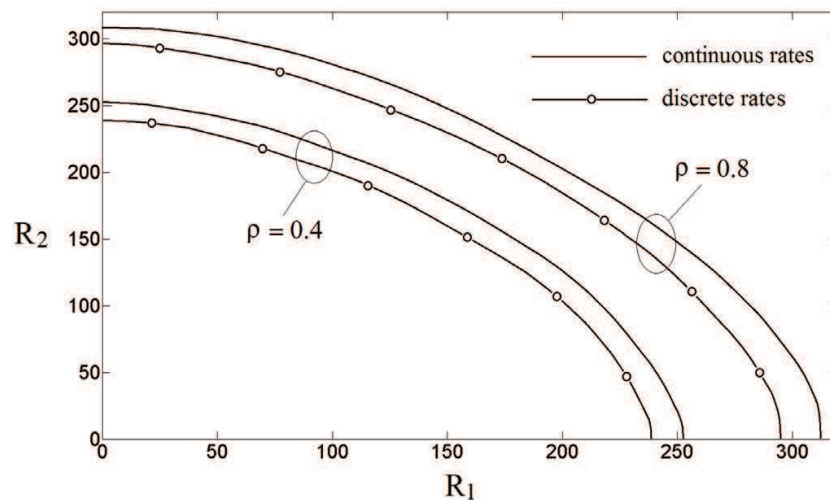

Fig. 19. Outage rate regions for different values of PDP exponential decay factor ( $\rho$ ).

channel realization is characterized by the rate region, whereas the overall performance of OFDMA in random channels is characterized by means of the outage rate region. The cases of continuous and discrete rate allocation are addressed under a general framework. The first case leads to mixed optimization problems, whereas in the second case, the optimal resource allocation is the solution of integer optimization problems.

By using the dynamic programming algorithm, the achievable rate region of OFDMA for different channels and system parameters has been computed. The simulation results show that the performance gap between continuous and discrete rate adaptation is quite narrow when the average transmit power per subcarrier is low, and it increases for higher values of transmit power. The frequency selectivity of the broadband channel has an important influence in the system performance. The higher the frequency selectivity, the more useful is the adequate resource adaptation. The gap between continuous and discrete rate adaptation does not depend on the frequency selectivity of the channel. The gap between continuous and discrete rate adaptation remains nearly constant for different values of outage probability.

## 7. Appendix: Dynamic programming

Dynamic Programming (DP) is a well-known mathematical technique for solving sequential control optimization problems with accumulative cost functions Bertsekas (2005). In a DP problem there is always an underlying dynamical discrete process governed by a set of system functions with the form

$$\mathbf{x}_{k+1} = f_k(\mathbf{x}_k, \mathbf{c}_k), \quad 1 \leq k \leq N \quad (20)$$

where  $k$  is an index denoting a stage in the system evolution,  $N$  is the number of stages,  $\mathbf{x}_k$  represents the state of the system at stage  $k$  and  $\mathbf{c}_k$  denotes the control action to be selected at stage  $k$  (see Fig. 20). In general  $\mathbf{x}_k \in S_k \subset R^n$ , so the subset of possible states ( $S_k$ ) can be different at different stages. In fact there is a fixed initial state  $\mathbf{x}_1 = \mathbf{x}^{(0)}$ , so the set of all possible states at the first stage has a unique value  $S_1 = \{\mathbf{x}^{(0)}\}$ . The control vector  $\mathbf{c}_k$  at each stage are constrained to take values in a subset  $C_k(\mathbf{x}_k)$ , which, in general, depends on the current state  $\mathbf{x}_k$  and on the stage ( $k$ ).

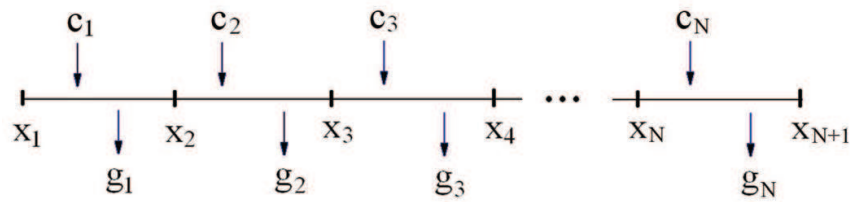

Fig. 20. Scheme of a DP problem showing the system states ( $x_k$ ), controls ( $c_k$ ) and costs ( $g_k$ ) at different stages

At each state the system incurs in an additive cost  $g_k(x_k, c_k)$ , which, in general, depends on the state and on the applied control. The objective is to minimize the total cost of the system along its evolution by selecting the optimal controls at each stage

$$\min_{\{c_k \in C_k(x_k)\}_{k=1}^N} \sum_{k=1}^N g_k(x_k, c_k). \quad (21)$$

Therefore, the elements of a DP problem are:

- The number of stages  $N$ ,
- The control vector  $c_k$ ,
- The state vector:  $x_k$
- The initial state:  $x_1$
- The subset of possible states at each stage  $S_k$
- The subset of possible controls at each stage  $C_k(x_k)$ ,
- System equation:  $x_{k+1} = f_k(x_k, c_k)$ ,
- Cost functions:  $g_k(c_k)$ .

In general, these problems are difficult to solve. A key aspect is that controls cannot be viewed in isolation since the controller must balance the cost at the current stage with the costs at future stages. The DP algorithm captures this trade-off. The DP algorithm simplifies (21) by breaking it down into simpler subproblems in a backwardly recursive manner Bellman (1957), which is described in the following lines.

The optimal cost from state  $x_k$  at stage  $k$  can be expressed as follows

$$J_k^*(x_k) = \min_{c_k \in C_k(x_k)} \{g_k(x_k, c_k) + J_{k+1}^*(f_k(x_k, c_k))\}, \quad k = N-1, \dots, 1 \quad (22)$$

$$J_N^*(x_N) = \min_{c_N \in C_N(x_N)} g_N(x_N, c_N),$$

and the optimal control policy at stage  $k$  for state  $x_k$  is

$$\mu_k^*(x_k) = \arg \min_{c_k \in C_k(x_k)} \{g_k(x_k, c_k) + J_{k+1}^*(f_k(x_k, c_k))\}, \quad k = N, \dots, 1$$

Finally, the optimal control sequence  $\mathbf{c}^* = [c_1^*, c_2^*, \dots, c_N^*]$  and the corresponding system evolution  $\mathbf{x}^* = [x_1^*, x_2^*, \dots, x_{N+1}^*]$  are easily obtained by iteratively applying the optimal control policies from the initial state as follows

$$\begin{aligned} \mathbf{x}_1^* &= \mathbf{x}^{(0)}, \\ \mathbf{c}_k^* &= \mu_k^*(\mathbf{x}_k), \quad \mathbf{x}_{k+1}^* = f_k(\mathbf{x}_k^*, \mathbf{c}_k^*), \quad k = 1, \dots, N \end{aligned} \quad (23)$$

## 8. Acknowledgements

This work was supported by the Spanish Government, Ministerio de Ciencia e Innovación (MICINN), under project COSIMA (TEC2010-19545-C04-03) and COMONSENS (CSD2008-00010, CONSOLIDER-INGENIO 2010 Program).

## 9. References

- Bellman, R. E. (1957). *Dynamic Programming*, Princeton University Press, Princeton, NJ, USA.
- Bertsekas, D. P. (2005). *Dynamic programming and optimal control, volume I*, Athena Scientific, Belmont, Massachusetts, USA.
- Boyd, S. & Vandenberghe, L. (2004). *Convex Optimization*, Cambridge University Press, Cambridge, UK.
- Cioffi, J., Dudevoir, G., Eyuboglu, M. & Forney Jr, G. (1995). Mmse decision-feedback equalizers and coding ii. coding results, *IEEE Transactions on Communications* 43(10): 2595–2604.
- Cover, T. M. & Thomas, J. A. (1991). *Elements of information theory*, Wiley.
- Goldsmith, A. & Effros, M. (2001). The capacity region of broadcast channels with intersymbol interference and colored gaussian noise, *IEEE Transactions on information Theory* 47(1): 219–240.
- Hoo, L., Halder, B., Tellado, J. & Cioffi, J. (2004). Multiuser transmit optimization for multicarrier broadcast channels: Asymptotic fdma capacity region and algorithms, *IEEE Transactions on Communications* 52(6): 922–930.
- Jang, J. & Lee, K. (2003). Transmit power adaptation for multiuser ofdm systems, *IEEE Journal of Selected Areas in Communications* 21(2): 171–178.
- Lee, L. & Goldsmith, A. (2001). Capacity and optimal resource allocation for fading broadcast channels - part ii: Outage capacity, *IEEE Transactions on information Theory* pp. 1103–1127.
- Ree, W. & Cioffi, J. (2000). Increase in capacity of multiuser ofdm system using dynamic subchannel allocation, *Proceedings of IEEE Vehicular Technology Conference (VTC'00)*, Tokyo, Japan, pp. 1085–1089.
- Seong, K., Mohseni, M. & Cioffi, J. M. (2006). Optimal resource allocation for ofdma downlink systems, *Proceedings of 2006 IEEE International Symposium on Information Theory (ISIT'06)*, Seattle, Washington, USA.
- Shen, Z., Andrews, J. G. & Evans, B. L. (2005). Adaptive resource allocation in multiuser ofdm systems with proportional fairness, *IEEE Transactions on Wireless Communications* 4(6): 2726–2737.
- Song, G. & Li, Y. (2005). Cross-layer optimization of ofdm wireless networks - part ii: Algorithm development, *IEEE Transactions on Wireless Communications* 4(2): 625–634.
- Tao, M., Liang, Y. C. & Zhang, F. (2008). Resource allocation for delay differentiated traffic in multiuser ofdm systems, *IEEE Transactions on Wireless Communications* 7(6): 2190–2201.
- Tse, D. & Viswanath, P. (2005). *Fundamentals of Wireless Communications*, Cambridge University Press, Cambridge, UK.

- Wong, I. & Evans, B. (2008). *Resource Allocation in Multiuser Multicarrier Wireless Systems*, Springer, New York, USA.
- Yu, W. & Lui, R. (2006). Dual methods for nonconvex spectrum optimization of multicarrier systems, *IEEE Transactions on Communications* 54(7): 1310–1322.

IntechOpen

IntechOpen

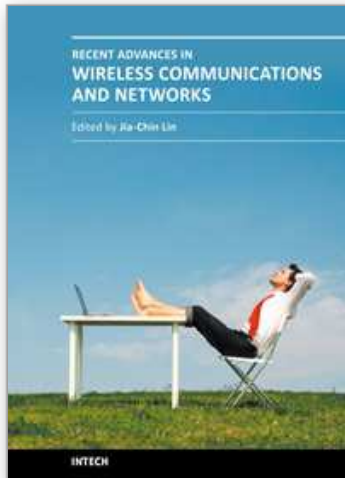

## **Recent Advances in Wireless Communications and Networks**

Edited by Prof. Jia-Chin Lin

ISBN 978-953-307-274-6

Hard cover, 454 pages

**Publisher** InTech

**Published online** 23, August, 2011

**Published in print edition** August, 2011

This book focuses on the current hottest issues from the lowest layers to the upper layers of wireless communication networks and provides “real-time” research progress on these issues. The authors have made every effort to systematically organize the information on these topics to make it easily accessible to readers of any level. This book also maintains the balance between current research results and their theoretical support. In this book, a variety of novel techniques in wireless communications and networks are investigated. The authors attempt to present these topics in detail. Insightful and reader-friendly descriptions are presented to nourish readers of any level, from practicing and knowledgeable communication engineers to beginning or professional researchers. All interested readers can easily find noteworthy materials in much greater detail than in previous publications and in the references cited in these chapters.

### **How to reference**

In order to correctly reference this scholarly work, feel free to copy and paste the following:

Jesús Pérez, Javier Vía and Alfredo Nazábal (2011). Optimal Resource Allocation in OFDMA Broadcast Channels Using Dynamic Programming, Recent Advances in Wireless Communications and Networks, Prof. Jia-Chin Lin (Ed.), ISBN: 978-953-307-274-6, InTech, Available from:

<http://www.intechopen.com/books/recent-advances-in-wireless-communications-and-networks/optimal-resource-allocation-in-ofdma-broadcast-channels-using-dynamic-programming>

**INTECH**  
open science | open minds

### **InTech Europe**

University Campus STeP Ri  
Slavka Krautzeka 83/A  
51000 Rijeka, Croatia  
Phone: +385 (51) 770 447  
Fax: +385 (51) 686 166  
[www.intechopen.com](http://www.intechopen.com)

### **InTech China**

Unit 405, Office Block, Hotel Equatorial Shanghai  
No.65, Yan An Road (West), Shanghai, 200040, China  
中国上海市延安西路65号上海国际贵都大饭店办公楼405单元  
Phone: +86-21-62489820  
Fax: +86-21-62489821



© 2011 The Author(s). Licensee IntechOpen. This chapter is distributed under the terms of the [Creative Commons Attribution-NonCommercial-ShareAlike-3.0 License](#), which permits use, distribution and reproduction for non-commercial purposes, provided the original is properly cited and derivative works building on this content are distributed under the same license.

IntechOpen

IntechOpen