

We are IntechOpen, the world's leading publisher of Open Access books Built by scientists, for scientists

4,800

Open access books available

122,000

International authors and editors

135M

Downloads

Our authors are among the

154

Countries delivered to

TOP 1%

most cited scientists

12.2%

Contributors from top 500 universities



WEB OF SCIENCE™

Selection of our books indexed in the Book Citation Index
in Web of Science™ Core Collection (BKCI)

Interested in publishing with us?
Contact book.department@intechopen.com

Numbers displayed above are based on latest data collected.

For more information visit www.intechopen.com



The Design and Implement of Wind Fans Remote Monitoring and Fault Predicting System

Yao Wanye and Yin Shi
*North China Electric Power University
China*

1. Introduction

In modern wind power farms, it is imperative to establish a remote monitor system to monitor the unmanned working process and the fans which working in the bad environment. Under this remote monitoring system, we realized the supervisory information of the wind farms, which similar to the SIS of fuel power plant, including: power forecasting of fans, fault predicting of wind generators and more. This article mainly introduced the OPC system for data collection, the virtual private network (VPN), the real-time data base monitoring and fault predicting. If the wind farms have been established electricity special communication network, we can apply for the special communication network to transfer data of fans and boost station, which will be more safety and steady. On the basis of these, the remote monitoring system has the function of fault predicting in control center. This system has been used in Hebei Construction and Investment New Energy and Datang new Energy.

2. Preface

Along with the global resources and environment worsening, the development and utilization of new energy has gotten more attention. While, comparing with traditional energy sources, wind energy is a clean renewable energy. It is not dependent on fossil energy, no fuel price risk, and no carbon emissions and other environmental costs. In addition, the availability of wind energy is widely distributed around the globe. Because of these unique advantages, wind power has become an important part of sustainable development in many countries. According to statistical report which Global Wind Energy Council (Abbreviation GWEC) edited, global wind power generator installed capacity has reached 158 million kW, the cumulative growth rate has reached 31.9%. To the end of 2009, worldwide there have been more than 100 countries that involved in wind power development, among them, there are 17 countries accumulative total installed capacity over million kilowatts. Large-scale wind power operation will increase uncontrolled power output, which will generates a lot of pressure for electric power dispatching.

In the wind farms, fans are widely distribution with large amount and they are away from the monitoring center, working environment is poor. In order to ensure the safe and stable operation of the wind farms, we need to satisfy the wind power operation requirements, own better function performance and stability of remote monitoring system to improve the

management efficiency. In view of this, the power group increasing highly requirements on wind farm group management, but at present, the single SCADA system which the fan manufacturers offered has failed to meet our requirements. With the investment of new energy, more and more wind farms will be building.

Currently, the wind farm supervisory control and data acquisition (SCADA) system are provided completely by fan manufacturers, the main problems are shown as follows:

1. Compatibility issues:

There are more than 40 companies engaged in research and development wind generator, and more companies are developing proprietary fans components or complete machine. Large-scale wind farm are generally provided by multiple vendors, the manufacturers of SCADA systems are not compatible, different types of fans lack of effective monitoring and management studies, it is difficult to unified maintenance and management.

2. Information development level:

At present, the problems of wind power still concentrate in the reliability of wind power generation, power prediction, and Security to the grid, etc. In the SCADA software, the application of information and centralized data collection is still the degree of showing. It is only available to supply operator real-time data and historical data without deeper level of information development, such as condition monitoring, fault diagnosis, operational guidance and so on.

On the basis, this article designs the wind farm remote monitoring and data analysis system to achieve a variety of fans in different wind farms, and realize wind farm cluster control and data analysis and fault warning.

2.1 The present situation and the solution of the wind farms remote monitoring system

First, because the existing wind farms adopt the monitoring system of the different fans of the manufacturer, the data between the different systems cannot fulfil resource sharing, and can't meet the needs of remote monitoring. Secondly, the wind farm applied to cluster control, which will facilitate different fans operating conditions and the output comparing. Third, the resolving of failure fans began to carry out after the fan malfunction happened, which is not conducive to run economy of wind farms. So we must build a fault early warning ways and improve the operation reliability of the wind farms.

Therefore, we are currently using remote monitoring system for wind farms, which refer to the experience of thermal power project. We have integrated the data that is from different fan manufacturers, and gathered real-time data of run fans and remote communication of booster station. It can realize the remote monitoring, data analysis and processing, provides management with the power plant in the various operating statements, on the basis of this, we also realize equipment fault diagnosis and life management of fans, wind power prediction, and other functions.

2.2 The overall program design of system function

The design of the system can be achieved parallel with the existing fan SCADA system, maintaining data integrity and continuity with kinds of fans running centralized display.

1. The maintenance of the wind resource information

Wind resource generally includes a number of wind farms, usually displayed in the map marked.

2. The maintenance of wind farm information
Maintain basic information of wind farms, fan information and electric price in tariff in a time period.
3. The maintenance of fans information
 - a. Maintain each fan's information, and marked on the map.
 - b. Providing for each class, each wind farm of the standard extension for comparison when doing technical analysis.
 - c. Each type of fan fault code table.
4. The maintenance of substation information

It include basic information and the wiring diagram of the wind farm, main transformer, circuit breakers, high voltage side arrester, reactive power compensation device, booster station and other equipment.

Remote monitoring system for wind farm should include the following function modules: real-time data collection and monitoring, remote centralized control, performance statistics and analysis, fault early warning, life management, output statistics and forecasts, operation optimization. The functional design should include three levels. First, the underlying data collection and monitoring, namely: using OPC technology to achieve real-time collection for fans and booster station, which save in real time / history stored in the database. By the way, it is shown in web as configuration mode. The second is the upper fault warning analysis, life management function, which including: equipment failure records, fan performance comparison, statistics and fan life management. The third level is a fan of the forecasting and planning, which is on the basis of meteorological data and historical data. This module can get fan's model to predict short-term and even medium-term output forecast for the power grid to provide scheduling support.

The module used to implement specified data collection from existing SCADA systems and substation system. Base on the Web application technology and Browse/Server (B/S) , when data uploaded to data center, users can access via IE overview of wind resources and wind farms, an operation status, substation operation, real-time wind data and other information, real-time operating status of individual fans, all kinds of alarm and fault information. this feature provide wind farm running status of monitoring real-time power and other information for leaders, and they can easily check the production of key information, including core businesses of production management, wind power generation, booster station operation and so on.

The figure of the physical structure of remote monitoring system of wind power is shown in figure 1.

Equip each of the wind farms with a front-end computer to collect the information of the running fans in wind farms and the booster station. The main task of front interface computer is collecting the data of the monitoring systems which are then organized into UDP packets, sent to the data repeater through the firewall, and finally stored in the real-time/historical data server. Develop the function of data cache in front-end computer to ensure that the data is cached when the link is interrupted while it is able to uplink data after the link is unblocked. Install redundant database services on the side of group center to store real-time data and historical data. The 500,000 points real-time\historical database of Tianren Huadian is chosen as the database. For the traditional fan monitoring system, one can enter the fan surveillance server (with a public IP) simply through the VPN client and a

simple password to monitor and control the operations of fans now, which does not meet the requirements of information security and must be improved. Cancel public network IP and all the information exchange with the outside world is to be conducted through a specified isolation unit. Apply optical fibre communication system to the communication link we use and a special 2M special line (E1 lines) used to transmit the information of wind farms is opened for all the wind farms, which in essence ensures the security of information exchange.

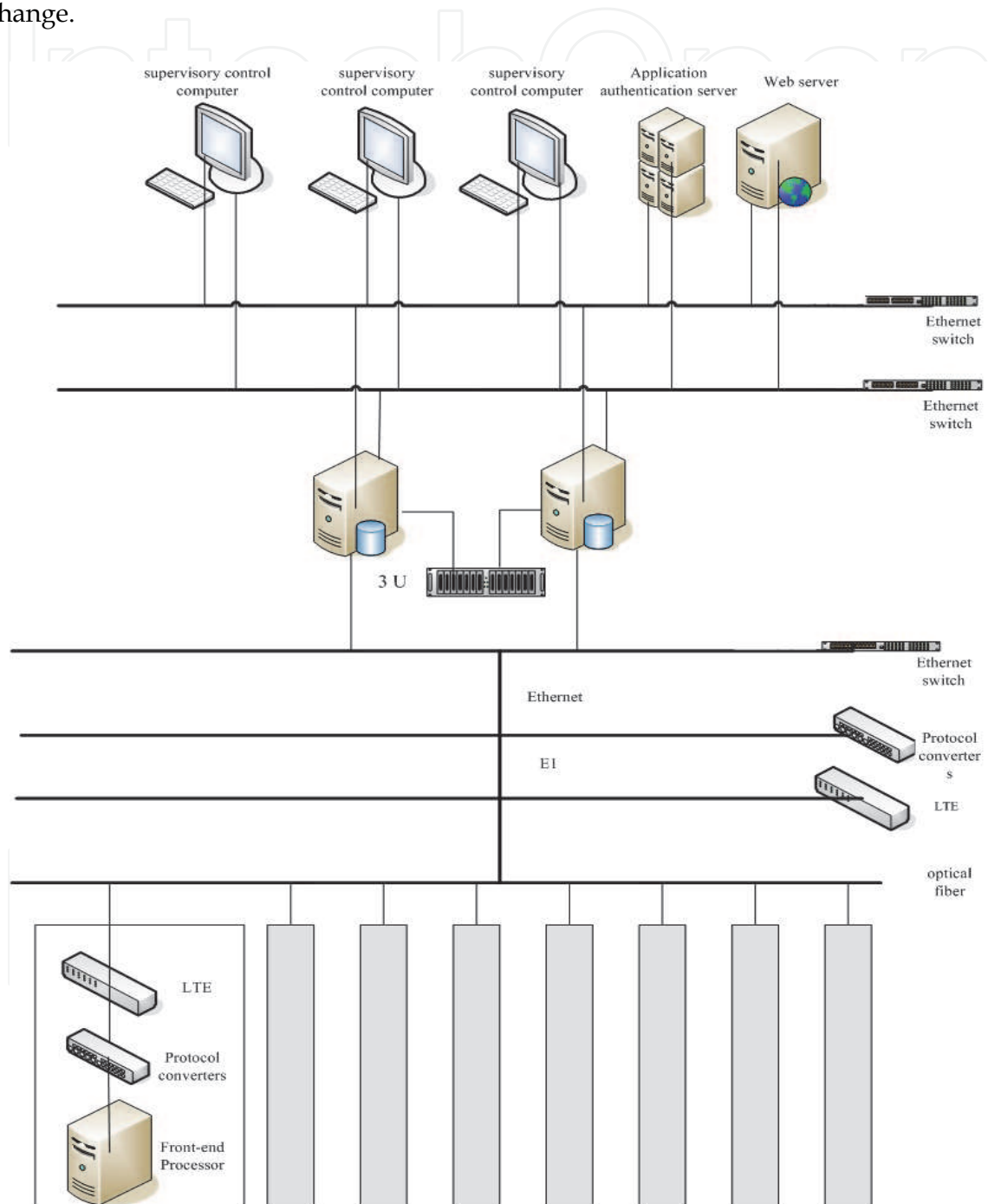

Fig. 1. The physical structure of remote monitoring system of wind power

The data which are lost due to network interruption or other reasons can be amended through manual labour. For areas with no broadband transmission, or no interconnected

network, we can export the data on the plant side, and then sent it to the group through other means to have the data import manually.

The data flow chart of remote monitoring system of wind power is shown as follows:

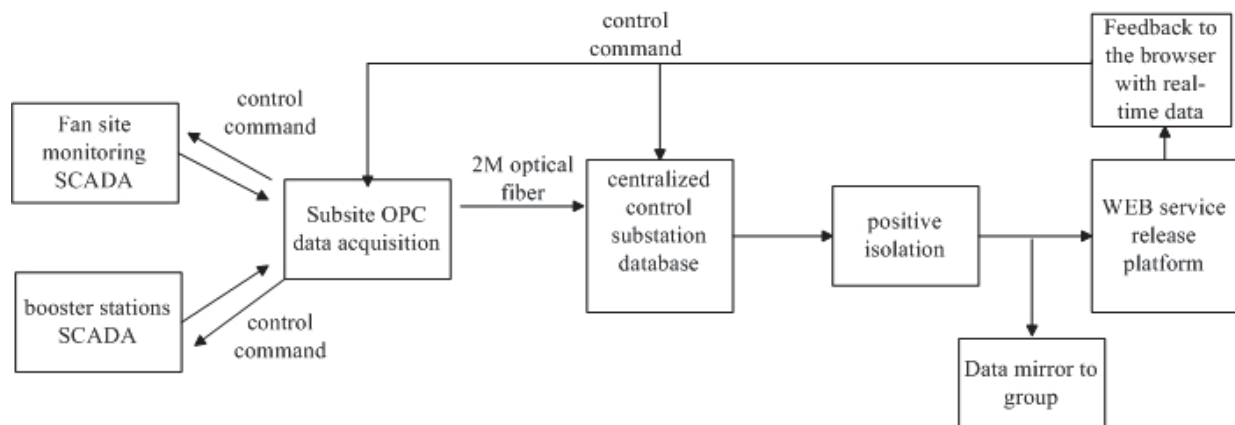

Fig. 2. The data flow chart of remote monitoring system of wind power

3. Design and development of SCADA system software

The software structure of the system is divided into 3 levels. The bottom level is the site monitoring software which can complete the site supervision of respective wind farms independently and is provided by the respective fan manufacturers. The middle level is the redundant real-time / historical database, which covers the storage of the data of fans and booster stations. The top level is software application Level, which completes the programming of plug-in applications and the analysis, processing and prediction of data.

The data level mainly focuses on collecting the operating parameters of wind fields and storing the data in real-time/historical database, with OPC as the collecting method. The application level deals with the applications of real-time database intensively, consisting of business components like business processing service, system authentication service, data connection service, application management system, etc. Those business components can be deployed flexibly in accordance with the actual situation. We can either centralize them on one single computer or choose to deploy them discretely. The chief function of the presentation level, in which the system and users interact, lies in accomplishing man-machine interface works like monitoring, operating, system management, etc.

The system adopts the application system structure in which B/S and C/S combine with each other, which can be configured flexibly according to the actual situation of the scene and user's requirements. It adopts application service based on .NET, fulfils system applications using SVG and XML technology and possesses advantages like easy maintenance, high efficiency, easy to transplant, etc.

3.1 The design and implementation of OPC interface

In a traditional system, application programs like supervisory control and data acquisition system (SCADA), human-machine interface (HMI), configuration software, etc. communicate with field devices through drivers. However, the driver has its own limitations. Different drivers need to be developed if we want to adapt a device to different client applications, resulting in duplication of labour. Once the hardware upgrades, the

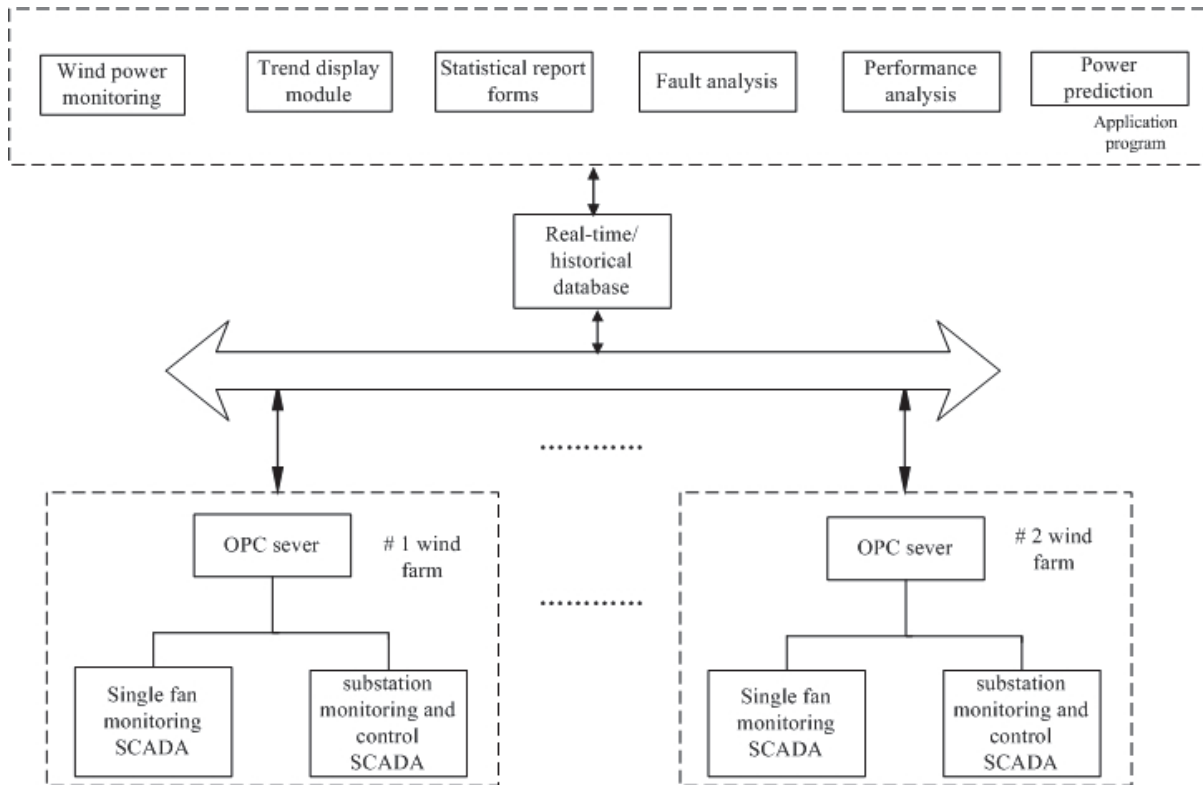

Fig. 3. SCADA software development diagram

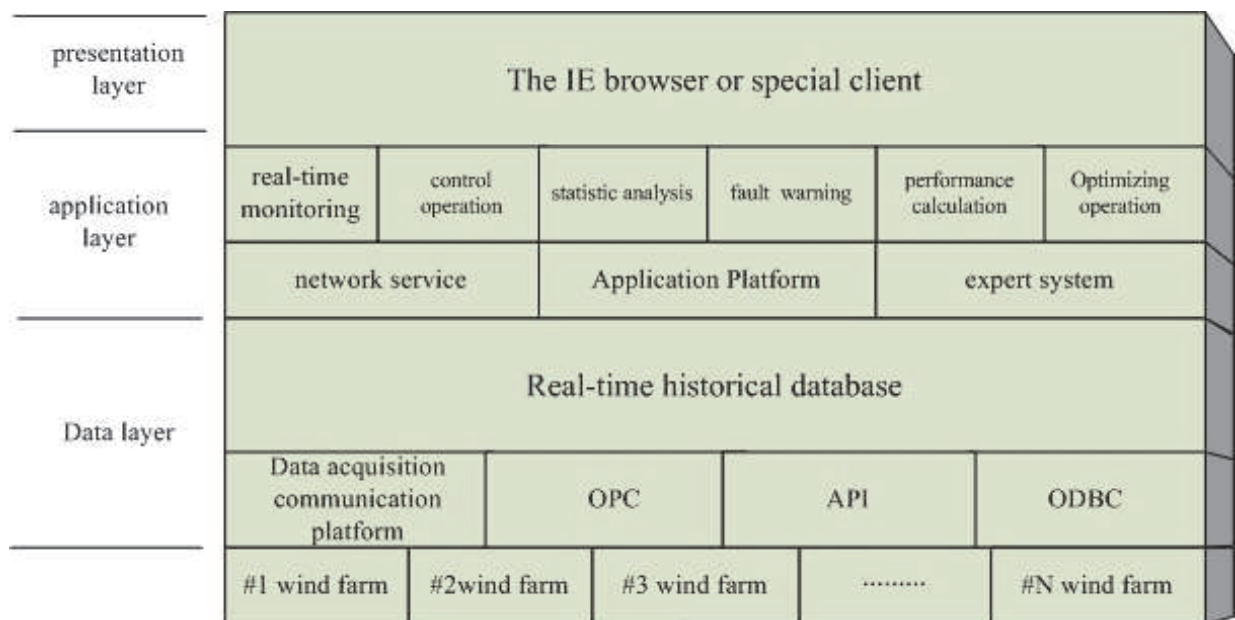

Fig. 4. The design of software structure

previously developed drivers should be modified accordingly. Normally drivers take the form of dynamic link library (DLL), and dynamic data exchange (DDE) is their primary means for data exchange. However, this approach does not allow the visit of multiple applications on one device simultaneously.

OPC (OLE for Process Control) technology comes into being in such a development background. OPC technology is an interoperability standard of industrial control software made by OPC foundation, and also a technology introduced jointly by the control fields and the Microsoft Company aiming at apply Windows to the control system. Based on the component object model / distributed component object model (COM / DCOM) technology of Microsoft, it defines a set of standard interfaces for industrial control software. Through these object interfaces, it realizes the standardization of the data exchange between applications, which greatly enhances the openness and interoperability between automated equipments.

OPC technology demands that hardware manufacturers must provide both equipments and OPC servers with standard communication protocols, while providers of SCADA system software provide client programs in line with the standards of OPC, thus SCADA can connect to OPC servers seamlessly. OPC interface can be applied to the lowest level of applications. That is, through this interface the real-time field data can be gathered and transmitted to DCS or SCADA system. Also by using this interface, we can transfer the data from the DCS system or SCADA system to the application software of upper layer. This contributes to the integration of management and control, and is beneficial to the computerized management of enterprises.

Under OPC, Client visit data in field data server through identical data access method. Though OPC servers may be offered by different software manufactures, an OPC Client can be connected to one or more different types of OPC servers. The structure of OPC applications is as follows:

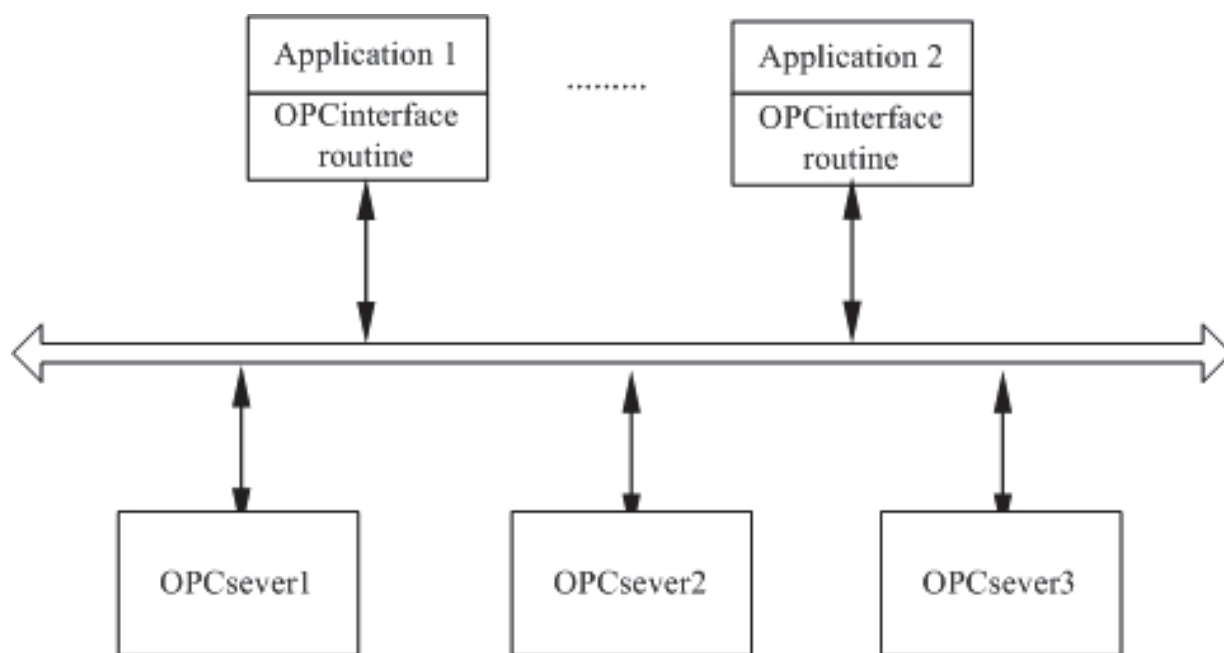

Fig. 5. OPC application program structure

3.2 The design of data acquisition system of front-end computer in wind farms

Since OPC defines a set of interface access methods based on the Microsoft OLE / COM or DCOM, applications which support or meet the OPC agreements can exchange data via OPC protocol if they can visit each other based on TCP / IP. Multiple network adapters

installed on the front interface computer of the wind farm need to be connected to the engineer station of the monitoring systems provided by fan manufacturers. As for its IP address, it should be in the same network segment with the engineers. The system structure is as follows:

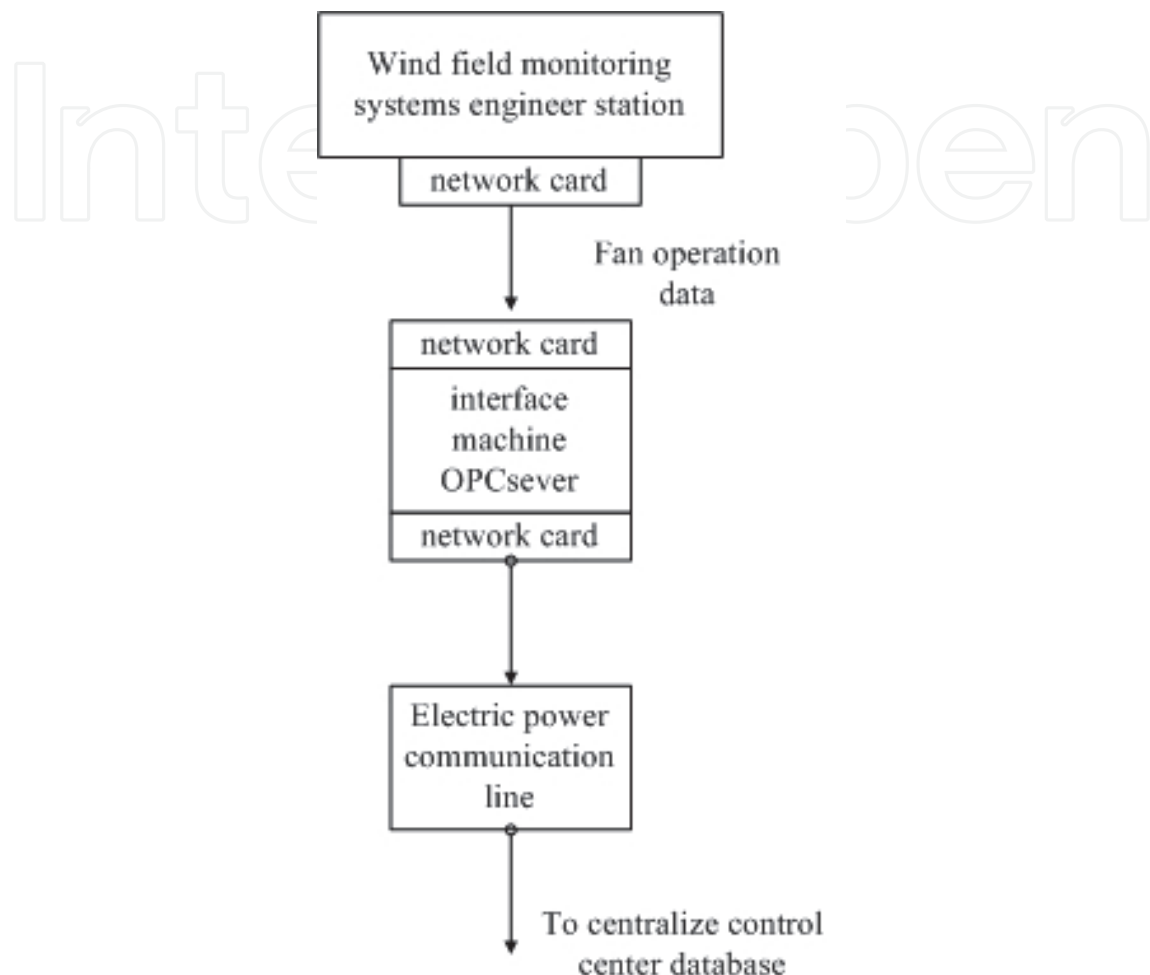

Fig. 6. OPC application program structure

3.3 The design of wind farm centralized control center

Install two database servers in Centralized Control Station for the storage of redundant wind field data, and they share memory way to increase system stability. Connect the network to the office network of New Energy Group as the subnet of the production system for the convenience of releasing information on the whole group web. Access permissions and strategies of the production subnet can be set in the planning of Group network.

Control station database pass to the Group side database system in way of the mirror function. The database server on Group side is deployed in the new energy group. Due to its high expansibility, system adopts SAN, which consists of two fibre switches, for storing. With the expansion of system capacity, the number of disk array and database servers can be increased randomly to achieve the expansion of storage capacity.

We install positive isolation device between the redundant database of centralized control center and Web server for the purpose of isolating fan control systems, substation control

system and real-time historical database system. It only allows the control system interface device to send data to the database system, which achieves unidirectional transmission of information and therefore ensures the security of production control system. The structure of centralized control station is shown as follows:

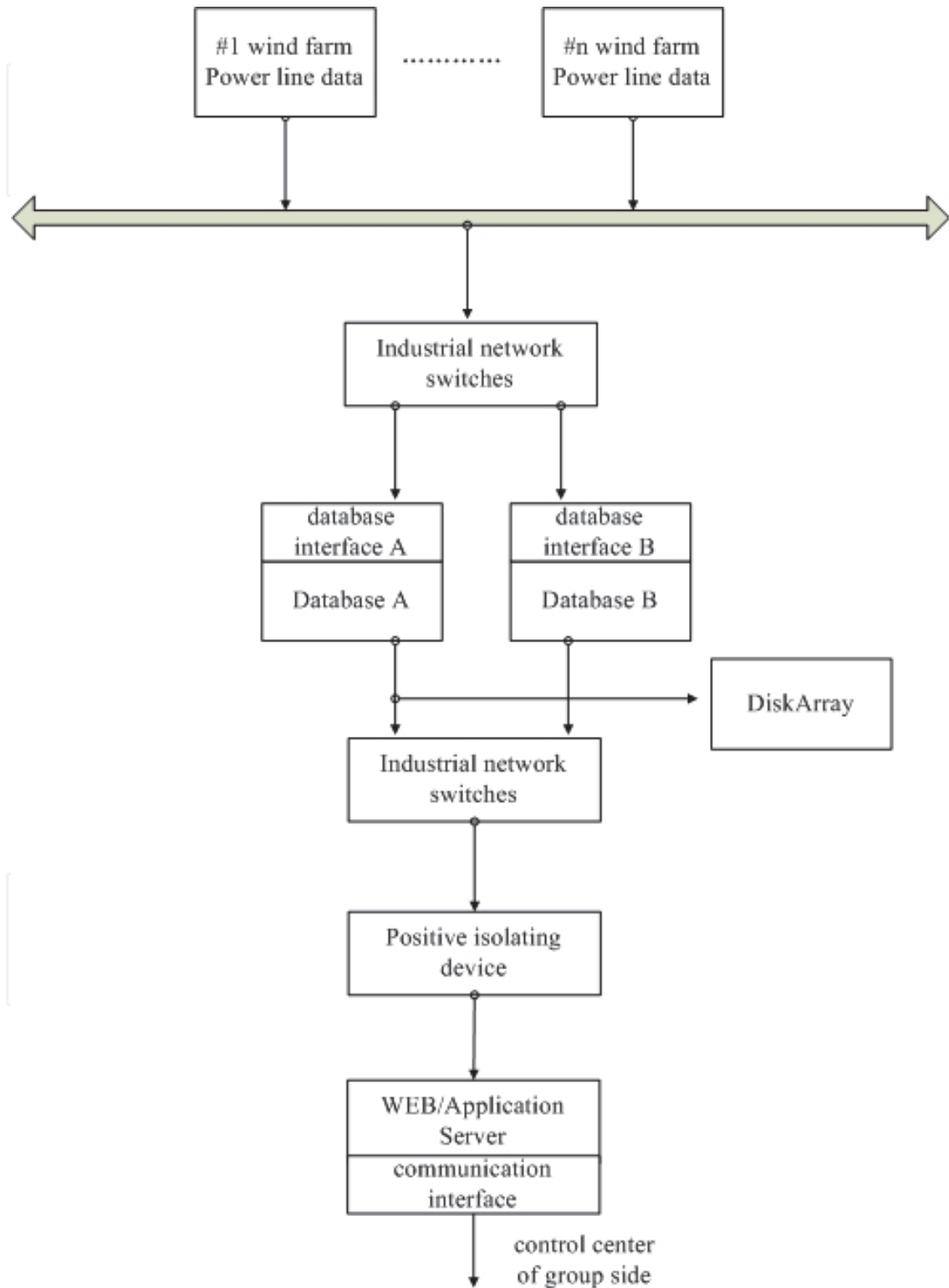

Fig. 7. OPC application program structure

The fan running data of multiple wind farms are uploaded to the redundant database of wind farm centralized control station side through the 2M communication line of their respective wind farms. The data in database is compressed and stored in extensible disk array. Positive isolation device is to ensure the unidirectional transmission of data from the wind side to the group side. Safe isolation network gateway (GAP) is needed. Users can get relevant information only after the digital identity certification. Security isolation gateway, consisting of software and hardware, is a network security device in which specialized hardware with multiple control functions cuts off the link layer connection between networks in the circuit and is able to carry out safe and moderate application data exchange between networks. The hardware device consists of three parts: external processing unit, internal processing unit, isolation hardware. When the user needs to ensure his network of high security while exchanging information with other networks which it distrusts, GAP is essential. Under that situation, using physical isolation card won't satisfy the demand of information exchange; using a firewall won't prevent the leakage of internal information, external viruses and the infiltration of hacker programs, therefore security can not be guaranteed. Security isolation network gateway, however, is the best choice for this circumstance since it can meet those two requirements at the same time and avoid the inadequacies of physical isolation card and firewall. The function of Web / Application Server is releasing data on the intranet of the company, thus any computer connected to the company intranet can share the data

4. Real-time/historical database

Data of Wind farms is the foundation of data analysis, data mining, control optimization and management optimization. There have to be thousands or even hundreds of thousands of data collecting units in one centralized control center which governs several wind farms. Due to the need for site monitoring and real-time analysis, the collected data is subjected to real-time changes. Such large-scale mass data is so difficult to be preserved for a long term in its prototype that the traditional relational database system is unable to accomplish this task at all. Therefore, real-time database comes into being.

Real-time database is the combination of real-time data and database, the key point in the development of which is the compression and storage of mass data. In addition, problems like real-time data model establishment, transaction scheduling methods, resources allocation strategies, real-time data communication, etc. also need to be solved in real-time historical database.

As for database system software, we should choose the large real-time historical database-VeStore widely used in power industry, the authorization point of which is 500,000 points. Database supports standard B/S (browser/server) structure, which can ensure all the real-time production process information of the electric field and calculation through effective compression methods. The recovery time of compressed data should not be more than 15 milliseconds and it should possess good expansibility and openness.

Real-time database should not only serve as the source of data needed in all the computing analysis programs, surveillance pictures, statistical forms and remote control and support standard linking approaches like application programming interface (API) and ODBC2.0, etc, but also provide the management information system (MIS) with required real-time data, calculation and analysis result. Its server and client hardware should be standard products from the third party, and the software module should fully support and be

compatible with the Microsoft system structure and have good transparency and secondary development ability. VeStore real-time database should have backstage calculation engine, a tool that can convert raw data into powerful information. All kinds of complicated second operation can be done through using configuration.

The real-time database should have perfect data mirror function, through which it can mirror the data center of the subsidiary to that of the group company.

5. Real-time/historical database

By processing real-time/historical data, Report capabilities should generate automatically daily reports, monthly reports, availability, power generation losses, etc. which shall be used to assess the running effects of fans from suppliers. Tabular forms should be offered to all kinds of users acting as a basis for management and decisions.

Reports completed by the system are mainly real-time reports, including:

I. Real-time load reports: generate real-time load reports which display information on units, the installed capacity of Wind Farms, load and load rate through classification approaches such as branches, unit capacity, etc.

The average availability in any given cycle of each wind turbine of a wind farm should be calculated as follows:

$$\text{Availability} = \text{TA} / \text{TCT} * 100\%$$

TA is the available time of a fan, namely the cumulated hours that fans operate or the time that fans possess operating conditions in any given cycle calculated by fan controller

TCT refers to all the calendar time calculated by hours within the computing cycles, for example, the TCT of the availability counted on an annual basis equals 8760 hours.

II. Reports on the start-stop condition of units:

Real-time unit start-stop report—employ flexible inquiry mode and display the present start-stop state of units according to query conditions like unit capacity, wind farm, etc.

Historical start-stop inquiry report—give a record of the start-stop conditions of units in wind farms, its history query time period can be selected arbitrarily.

III. trend analysis reports:

All the parameters can be displayed in multi-forms like trend chart, bar chart, related parameters groups, etc., displaying parameters value in real time and the maximum value, minimum value and average value in defined time period.

IV. unit real-time comparative reports:

The inquiry approaches designed in the system is flexible; it is inquired according to unit capacity and wind farms. You can choose any units or parameters that need to be compared from the units connected to the system to form real-time report of the comparison between parameters.

Reports involved in this system:

1. Start-stop records of fans;
2. The monthly availability of fans in wind farms;
3. The availability chart of several units in different wind farms;
4. The loss analysis table of fan failure;
5. The loss analysis diagram of fan failure;
6. The fault frequency and time contrast of each wind farm;
7. The failure frequency of various types of fan and the comparison chart of power loss;
8. The time proportion of all the running states within given time in wind farms;

9. Comparison of fan power curve;
10. Generating capacity of wind farms;
11. The comparison chart of on-grid energy and repurchase power;
12. Monthly charts of Power generating capacity and on-grid energy;
13. The generating capacity and on-grid energy comparison chart shown in Year / month;
14. The monthly contrasting chart of expected generating capacity and the actual generating capacity;
15. The wind speed- wind rose;
16. Wind energy - wind direction and the actual power generation contrast rose;
17. The trend diagram of monitored data and time (historical changes in blade angle, power, wind speed and blade angle);
18. Wind speed and wind wheel rotate speed curve, the wind farm operating comprehensive daily report;
19. Failure frequency reports of all types of fans;
20. Failure frequency reports of all types of fans and power loss;
21. Unit failure frequency reports and the time report;
22. Generating capacity of all the farms, utilization rate reports;
23. The cost report of the field operation and maintenance;
24. The main interface of wind farm operation and the integrated information of wind farms;
25. The display of instantaneous information of single wind turbine;
26. The caption of fan in different states;
27. The real-time curve of the instantaneous wind speed in wind farms;
28. The historical data Display of wind farms, etc.

The comparison of average wind speed this month and last month in wind farms monitored by centralized control station are shown in Figure 8:

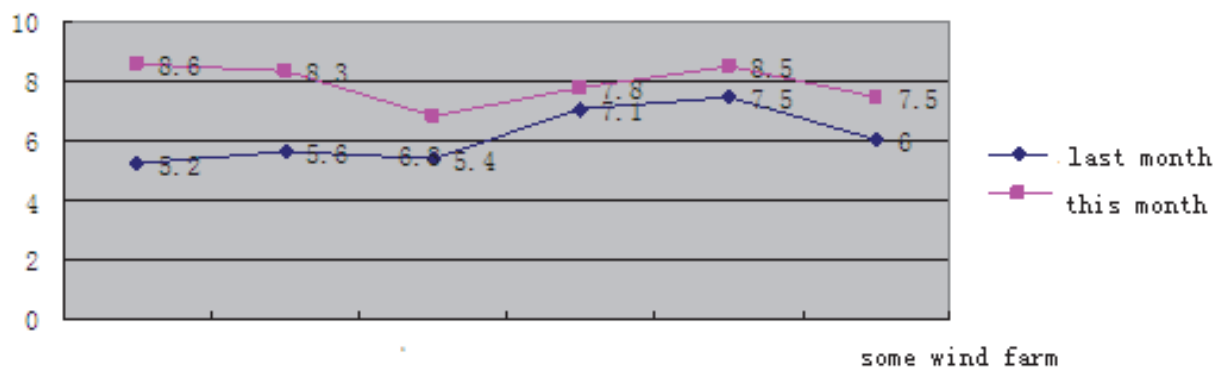

Fig. 8. The comparison chart of average wind speed this month and last month in some wind farms

6. The realization of advanced functions of wind power operation

6.1 The wind units state detection and early fault warning

Wind farm remote monitoring system will monitor and process the real time data condition of fans operating on-line and make a classification of fans under states such as running, fault, overhaul, reset, etc. It takes the structure of chain components, variable speed running

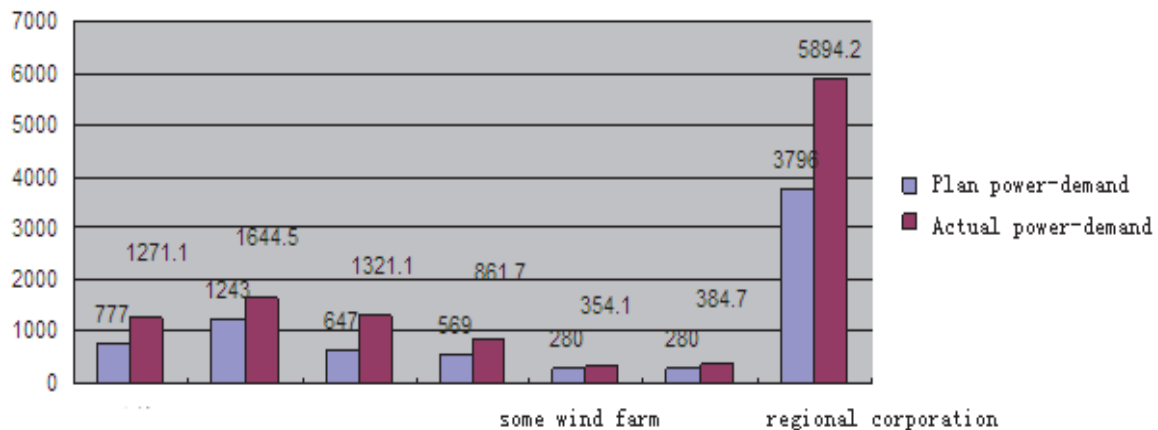

Fig. 9. The comparison chart of plan power-demand and actual power-demand in some month

The real-time data and historical data query from 0 to 16 o'clock is shown in Figure 10:

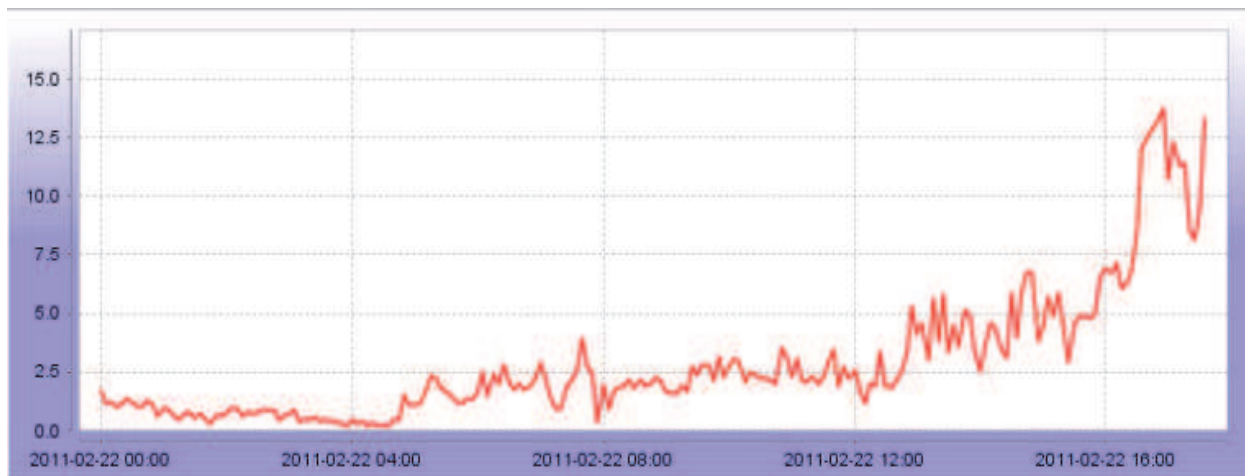

Fig. 10. Real-time data and historical data query from 0 to 16 o'clock

condition and hostile using environment such as high or low temperature into consideration. Through the use of reliable data collection system and international advanced fault diagnosis technology, it makes accurate judgment on the location where fault occurred and conducts remote and real-time monitoring of the running states of fan transmission chain (spindle, gear box and generator, etc.), the engine, vanes and tower drum, etc. It pre-warns diagnoses and analyzes the equipment faults. Abnormal states occurred in operation such as the malfunction of transmission device and generators caused by device state imbalance, rolling bearing damage, correcting error, etc. are detected out before fan fault happens. Thereby early fault diagnosis is achieved to determine the properties, types, location, degree, cause of faults. Then it points out the development trends and consequences, puts forward countermeasures to control its continued development and eliminate faults, and makes a classification of the fault types automatically. The faults include inverter reset overtime, generator speeding, temperature being exorbitant in high voltage transformer, temperature being too low in the cabin, etc. If failed to detect the fault, it will give rational proposals and instruct maintenance engineers to accomplish the

overhaul of the fan. It also provides scientific basis for the preventive maintenance by users, thereby reducing fan maintenance cost significantly.

It monitors multi-groups of data simultaneously, including: rear bearing and fore bearing rotation speed and vibration of Generator, rotate speed of high-speed shaft, cabin yaw state, gearbox low speed shaft, intermediate shaft, high-speed axis, input shaft, the gear ring vibration and oil temperature, vibration condition of Spindle fore bearing and spindle rear bearing, leaf temperature freezing, etc. Through the establishment of condition monitoring library of wind turbines of the same type, fans with big state variation are acquired automatically for fault forecast and analysis, thus completing fault pre-warning. Fan monitoring scheme is shown as follows:

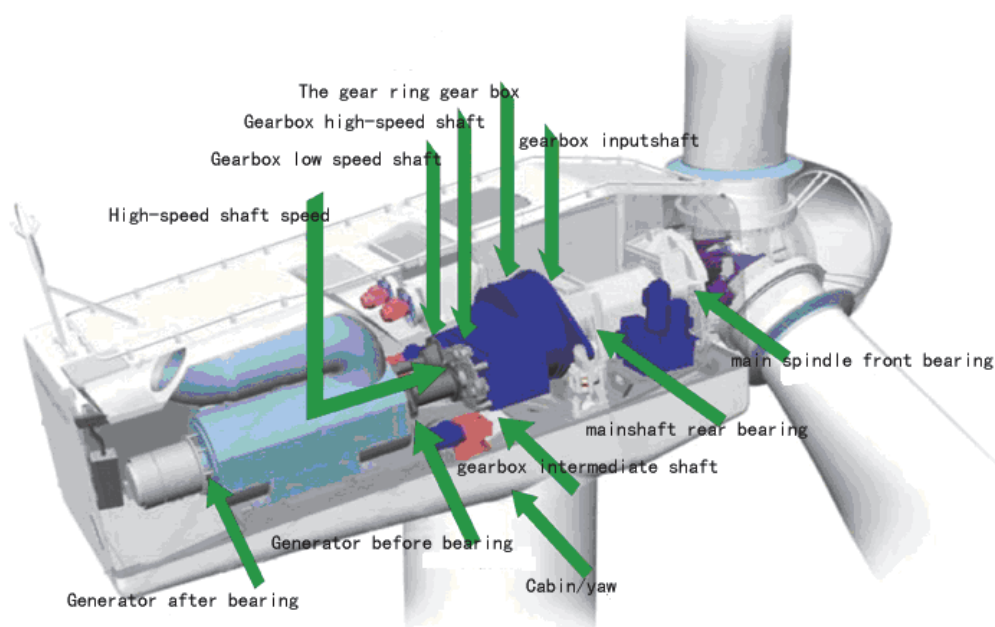

Fig. 11. The scheme of fans' monitoring

1. The reliability statistics evaluation scope of fan unit is bounded by export master switches of wind turbines, including wind wheel, transmission variable speed drive system, generator systems, hydraulic system and yaw system, control system, communication system and corresponding auxiliary systems.
2. The reliability statistics evaluation of wind farms includes all the generating equipments. Besides wind turbines, it also includes box transformer, confluence lines, main transformer, etc, and corresponding accessory and auxiliary equipment, common system and facilities.

6.2 Fan operation optimization

After wind farms are connected to grid, output of the regular generating units in the system shall change due to the injection of wind power. Since wind power is a constantly changing, we must keep adjusting and compensating the regular generating units in the system in accordance with the changing of wind power so as to keep the system in a certain balance

state. In the operation process of the wind power system, all the electric parameters of the system will change accordingly. Due to the increase of wind farm capacity, it will lead to bigger changes of the transient states of node voltages, system frequency, etc. When the proportion that the capacity of wind farms occupies in that of system reaches a certain level, some of the electric parameter indexes of the system will surpass the allowed range and the system might lose stability. Therefore, the low voltage ride through ability of wind farms is introduced.

When the proportion of the installed capacity of wind power in electric system is relatively large and the power system malfunction caused the fall of voltage, the off-grid of wind power shall influence the operation stability of system seriously, therefore wind turbines should possess low voltage ride through (LVRT) ability to guarantee the uninterrupted grid-connected operation of wind generators after system failure.

Wind generators should possess low voltage ride through ability:

- a. Wind farms must possess low voltage ride through ability to maintain operating 620ms when voltage has dropped to 20% of the rated voltage;
- b. Wind farms must keep grid-connected operation when the voltage of wind farms is able to recover to 90% of the rated voltage within 3s after it felt;
- c. Wind power must keep uninterrupted grid-connected operation when the voltage on the high voltage side of the substation in wind farms is not lower than 90% of the rated voltage.

The acceptable wind-power capacity of power system is influenced by factors like grid transmission capacity, peak load adjusting capability, degree of stability, voltage fluctuation, etc, among which the peak load adjusting capability that the grid can provide for wind power is the most fundamental restraining factor, which is closely related to system load property, property of power and output power size. If grid-connected wind power exceeds the peak load adjusting limit that the grid can, it would be difficult to balance wind power output, leading to the out of limit of frequency and even break down of the grid in a serious situation. Since the ability of Grid system to accept wind power is restricted, added by the uncertainty of wind power, power quality and power system operation shall be seriously influenced after the wind penetrate power exceeds a certain value. Scholars have done a lot of research work in this field and points out that the current acceptable wind power of the grid in China cannot exceed 15%. Therefore, enhancing the security construction of grid is significant to the connecting of wind power to grid. If wind speed and wind power can be accurately calculated, it will be helpful for the dispatching departments in power system to make timely adjustments on dispatching plan and the adverse impacts of wind farm on power system shall be effectively reduced or avoided.

Fan operation maintenance optimization decision support system mainly includes: establish mathematical model and simulation system of wind power equipments; study the operating rules of wind generator and optimize operation system, combining the condition monitoring analysis and diagnosis system, adopting the form of unattended or less people on duty, establish wind power operation maintenance system which combines with wind power information system to improve the operation efficiency of the wind system.

The biggest difference which distinguishes wind power from other energies lies in the random variation and uncontrollability of its source power. Wind speed is not only influenced by large-scale atmospheric motion, but also affected by micro-scale atmospheric turbulence movement caused by many kinds of surface factors; therefore the wind speed presents strong random properties on instantaneous changes of time and space. Many key

techniques in wind turbine control and wind farms grid-connected operation are developed to adapt to the randomness of wind variation.

Wind power generation leads to the increase of uncertainties in power system due to the randomness of wind power, which raises new challenges for the safe operation of power system. If we were able to make relatively accurate predictions on the wind speed in wind farms, it would help the dispatching departments in power system make advanced adjustment on dispatching plan when necessary, which can effectively reduce the influence of wind power on grid security.

With the increase of the proportion of wind generation in the power source structure of power grid, the randomness, intermittent and volatility of wind generation bring a series of problems to grid operation security. The dispatching departments can only roll blackouts to cope with those problems at the moment. Effective predictions on fan generating can help the dispatching departments in power system make various power dispatching plans so as to reduce wind power brownouts, thus reducing the economic loss that power brownouts bring to wind power owner and increasing the return of investment in wind power.

Wind power prediction module possesses high precision data meteorological forecast function, wind power signal purification, high-performance space-time model classifier, networked real-time communication, general wind power information data interface and other high-tech modules. It can accurately forecast the load of wind farms in future 168 hours - time curves, which will help wind farm production personnel arrange reasonable operation patterns for wind farms and reduce discarded wind. The average forecast precision rate of the system is over 80%, which can meet the electric load dispatching requirements in wind farms. The system is up to the individual wind power at the prediction error less than 25%.

The functional principle diagram is shown below:

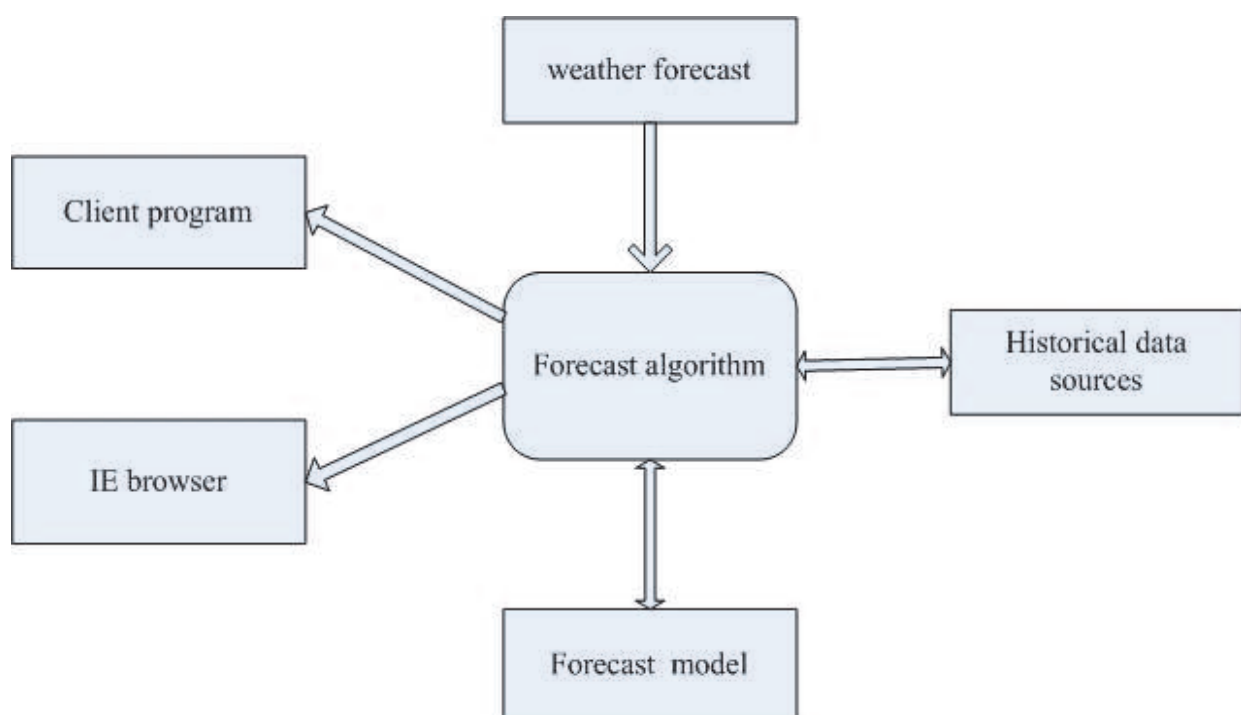

Fig. 12. The diagram of wind power prediction function principle

Prediction error of wind speed in wind farms is mainly decided by forecasting method, prediction cycle and the wind properties on the prediction site. Generally speaking, the shorter the forecast cycle is, the more moderate the variation of wind speed on the prediction site is, the smaller predicting error will be; on the contrary, the predicting error will be bigger.

The present prediction methods of wind speed mainly include Kalman Filtering method, random time sequence method, artificial neural network method, fuzzy logic method, spatial correlation method, etc. Random time sequence method needs a large amount of historical data in modelling, but it can set up a prediction model only by knowing a single speed in wind farms or a power time sequence. Spatial correlation method, taking many groups of data of wind speed in wind farms and several neighbouring sites into account, makes wind speed prediction using spatial correlation between wind speeds of several sites. Its collection of original data is enormous, but due to the increase of issues that should be taken into account in the prediction process, the prediction effect of spatial correlation method is relatively good. Artificial neural network possesses features like parallel processing, distributed storage and fault-tolerance, etc, and capabilities such as self-study, self-organization and self-adaptive, which are effective in solving complex problems. It can be used in wind speed prediction but problems like slow training speed exist.

Support vector machines (SVM) further explain the institutions risk minimization principle in learning theory, the prediction effect of which is good. Support vector machine seeks optimal compromise between the complexity of model and learning ability according to the limited sample information in order to obtain better generalization ability. Support vector machine is similar to multilayer feed forward networks in form, and it can also be used in pattern recognition and nonlinear regression. Support vector machine is most practical in speed prediction considering the highly nonlinear of wind speed data.

Calculation of the system uses support vector machine approach and adopts Gaussian radial basis function as its kernel function. It establishes regression estimation function expression using the regression estimation algorithm based on support vector machine and shows us the network structure of support vector machine. Due to the highly nonlinear of wind speed, point estimate of the relevant data constitute the training sample, and solve objective function. Point the relevant data to constitute the training sample, and solve objective function

Gray GM (1, 1) model is widely used in production researches like the load prediction of power system and possesses high forecast precision. Since the GM (1, 1) model is an exponential growth model and wind speed is a complex nonlinear systems affected by many factors, especially sensitive to seasonal change, taking one growing trend into consideration is not enough. Accordingly, the prediction accuracy of wind speed with periodic fluctuations is unsatisfactory. In order to improve the prediction precision and expand model applicable scope, we could promote GM (1, 1) model to GM (1, 1, λ) model and then build up corresponding differential evolution method to solve the model. Compare the prediction values acquired through two kinds of forecasting methods, select the result with small errors and conduct the prediction and calculation of wind power. This system adopts both Support vector machine and Gray prediction in its prediction, and then it fuses the acquired information using information fusion technology to get preferable prediction effects.

Power of wind generator is mainly decided by the wind speed of the place where blades locate. If the wind speed is below a certain value, the wind generator cannot generate

electricity and power output is zero; while when the wind exceeds a certain limit, wind-driven generator will brake automatically for the sake of self-protection, power output of the wind-driven generator in this situation is zero as well. Power properties of wind generators are shown below:

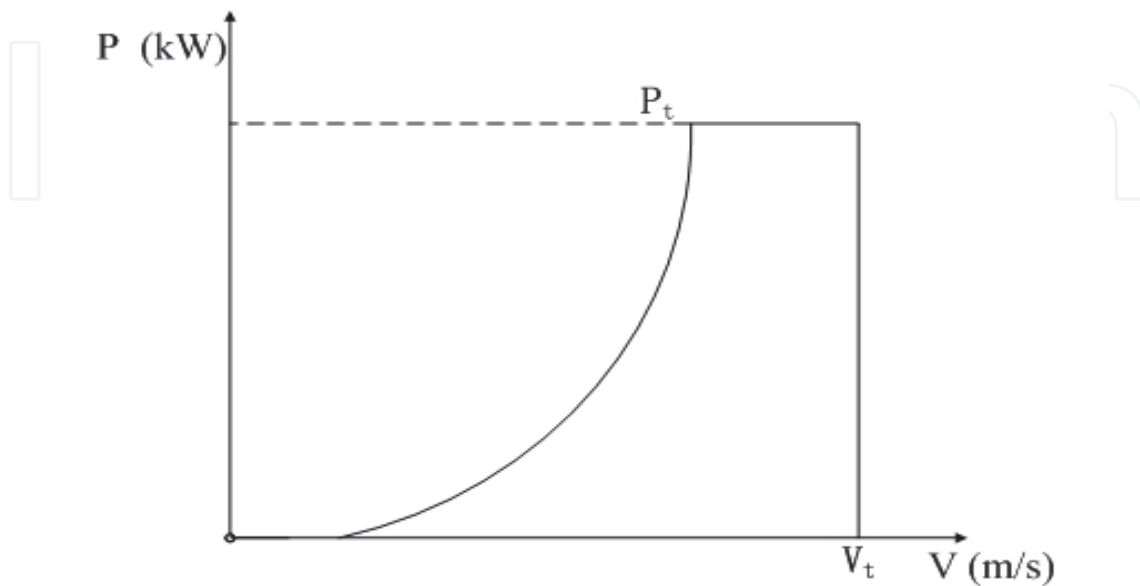

Fig. 13. The wind generators' power characteristics

The wind power is cube to the speed of wind. Wind power forecasting and wind speed forecasting follow the same principle, but the prediction error of wind power is greater than that of wind speed, the main reason of which lies in the corresponding relationship of wind speed and wind power generation.

The comparison chart of forecast power and realistic power is shown in Figure 14.

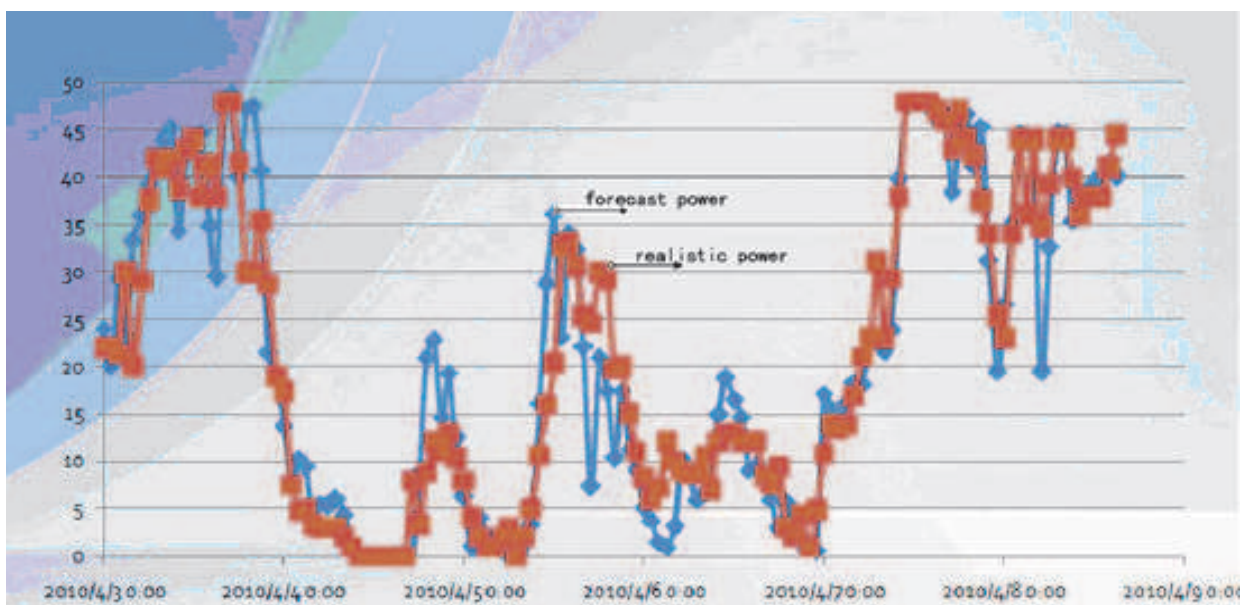

Fig. 14. The comparison chart of forecast power and realistic power

Wind speed predictions in wind farms is a most important means in reducing undesirable impacts of wind power on power grid. One of the most typical applications of it is in the real-time control of wind farm and grid scheduling. Make further decisions based on the information acquired after corresponding calculation and processing according to the wind forecast value given by wind speed forecast system, thereby AGC—power grid dispatching power setting and automatic power control is realized finally.

The traditional economic dispatch in power system is divided into static optimal scheduling and dynamic optimization scheduling. Static optimal scheduling only seeks optimal target at certain time section of the power system without considering the intrinsic link between different time sections; while the dynamic scheduling takes the coupling of different time sections into account, thus its calculation process is more complex than that of static optimal scheduling, but its result is much closer to actual requirements. As wind speed changes randomly, dynamic model is more suitable for the economic dispatch of power systems with wind farms.

Automatic generation control is achieved through a closed-loop control system. It gets real-time measurement data from SCADA, calculates out the control commands for each power plant or unit, and then sends them to the controller of each power plant though SCADA. The power plant controller adjusts the unit power and makes it track the control commands of AGC

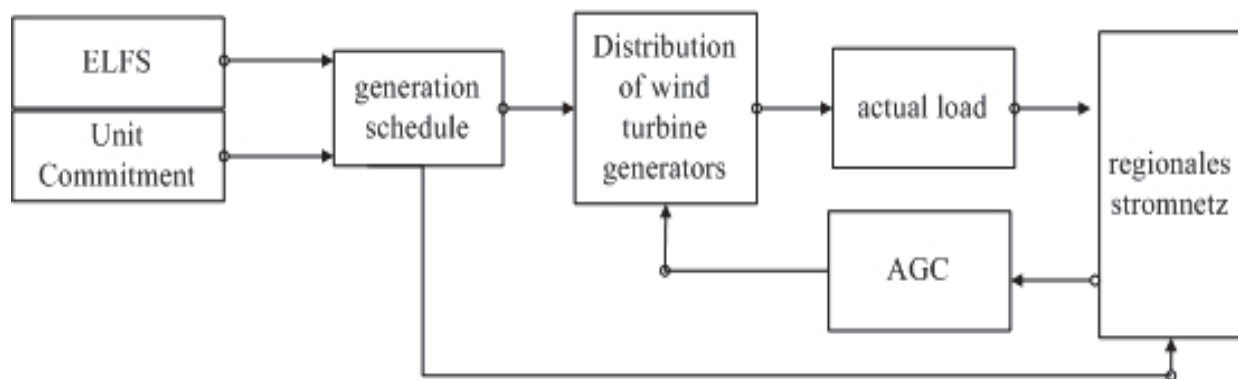

Fig. 15. Automatic generation control(AGC)

At first, wind farm centralized control center formulates a generation plan based on the wind power forecast system of wind farms and reports it to the regional grid dispatching company, and then the dispatching company distributes power generating units according to the generating schedule. When the actual load is inconsistent with the planned power, grid dispatching will reflect the deviation to units and make timely adjustments, thus achieving the purpose of automatic control.

7. Data collection and analysis of the booster station

The preliminary design of the booster station data acquisition of this system is to collect remote metering, remote surveillance, and remote regulating from wind field booster station SCADA. The program has been carried out in Hebei Construction Investment New Energy and the results are good. There's a centralized control system aiming at booster station in the present centralized control station named RCS-9001 SCADA, which includes analogue

(P, Q, I, U, f, etc.), status quantity (switch, knife switch, accident total signal and protective device movement and status signal), electric power with time, BCD code, accident sequential record (SOE), plan value curve and protective device installation value, measured value, action message, warning information, regression signal and so on.

The repeater communication is an essential work in the centralized control station system. As the relationships between scheduling systems are becoming closer and closer, the repeater content are increasing. RCS-9001 is as a platform for dealing with the repeater, which can define the forwarding of any data in the database and define the forwarding cycle of different data. It is capable of communicating with other monitoring station systems and interconnecting with other SCADA systems.

With the development of substation integrated automation, acquiring booster station data from the RCS-9001 SCADA system is more reasonable and convenient. The communication protocol we chose is the NARI DISA communication protocol, which is developed based on the DL451-91CDT protocol.

The chart below is a wiring diagram of a wind farm, which shows the remote metering, the remote surveillance, etc.

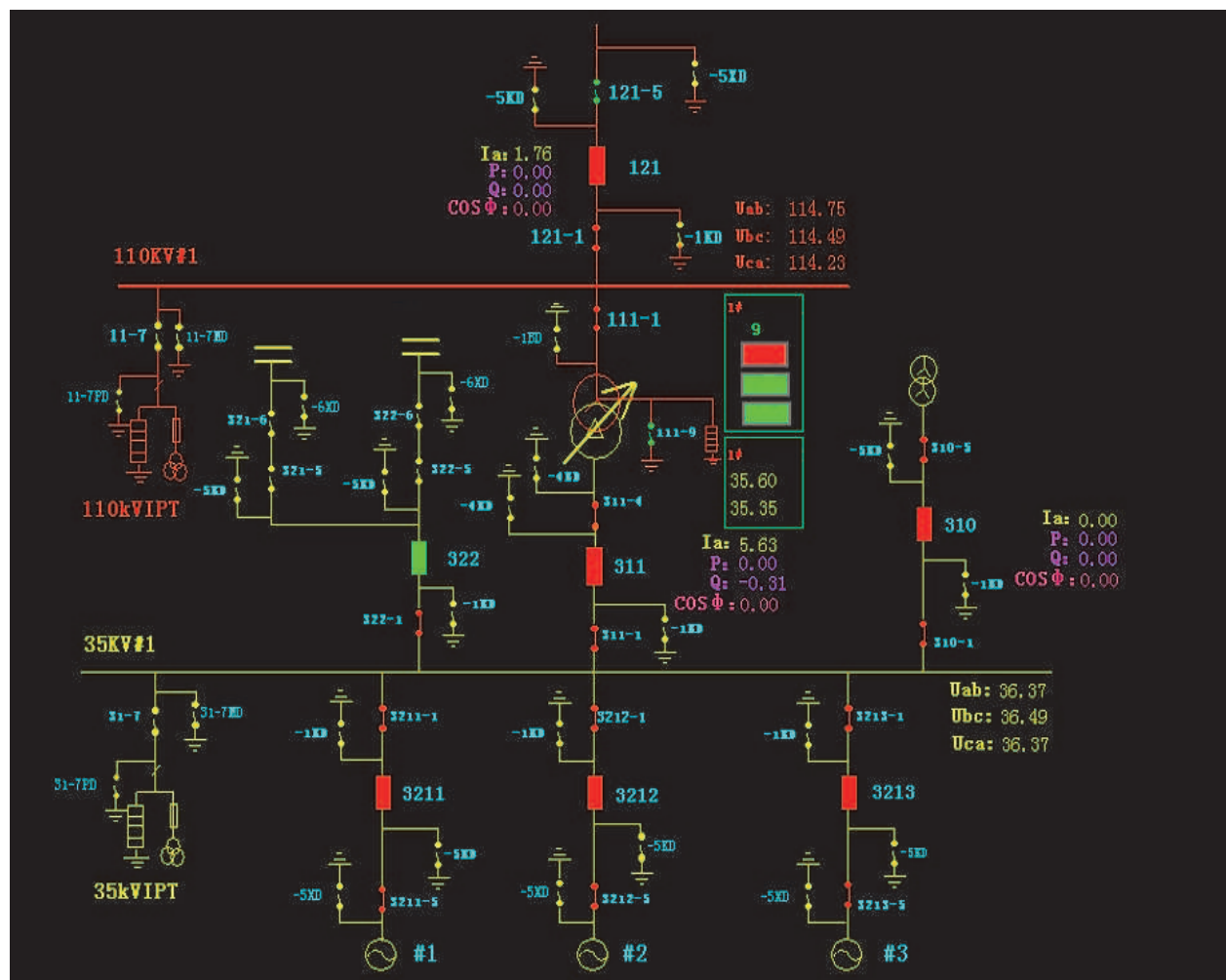

Fig. 16. Automatic generation control(AGC)

8. Conclusion

With the actual project of wind power remote monitoring and fault pre-warning as its background, this article introduces the overall system development process, network topology, the OPC data acquisition system on wind farm side, the real-time / historical database of control station. This system releases data through the B/S platform and offers information on the monitoring and operation state of wind turbines, real-time power, etc. Users can easily check the main production information of company including the core business of production management like wind power operation, booster station operation, etc. and contents like production logs. You can acquire real-time production information from macro to micro quickly, easily and quite friendly by browsing a page.

The paper also introduces emphatically the data analysis and fault alarm function of wind farms, including:

1. Monitor and process the real-time on-line operation data state of wind turbines; make a classification of wind turbines under the states of running, fault, overhaul and reset and establish the condition monitoring library for wind turbines of the same type, which picks out the operating wind turbines with big state variation automatically and conducts fault prediction and analysis, thus accomplishing fault pre-warning;
2. Establish mathematical models of wind power equipments and a simulation system; optimize the operating system combining condition monitoring analysis and diagnosis system through the wind generator operating rules, and establish the wind power operation maintenance system which combines with the wind farm information system.
3. Both support vector machines and Grey prediction are used in prediction; conduct real-time forecasts on the wind load of the future 168 hours using the information fusion technology; help the production personnel of wind farms arrange reasonable operation modes for wind farms, reduce discarded wind, and increase the investment return of wind farms.
4. Make predictions on the wind speed in wind farms to reduce the undesirable impact of wind power on grid; get relevant information after corresponding calculation and processing according to the predicted value of wind speed given by the wind speed prediction system; then make further decisions based on that information, thereby realizing AGC - dispatching power setting and automatic power control.
5. DISA communication agreement is used in gathering information of the booster station to achieve the collecting of remote metering, remote surveillance, remote regulating, and realize wiring diagram of substation.

The aim of Wind power remote monitoring and fault pre-warning system is to accomplish the information platform of wind power enterprises and provide timely, complete and accurate information service, helping wind power enterprises improve their modern management level and realizing data share in all aspects. Wind firms production computerized management platform is built up according to the ideas of integration, platform initialization and componentization using the most advanced computer technology. Based on the most advanced enterprise production integrated management system, the system successfully carries out computerized managements according to the profession features of wind power companies on the operation of wind power companies, maintenance, statements, aided decision-making, prediction control, etc.

9. References

- Ye Chaobang. The design of OPC sever with data require. North China Electric Power University. 2006.
- Vu Van Tan, Dae-Seung Yoo, Myeong-Jae Yi. Design and Implementation of Web Service by Using OPC XML-DA and OPC Complex Data for Automation and Control Systems. The Sixth IEEE International Conference on Computer and Information Technology, 2006.
- DCOM configuration illustrates. Huaifu opctkit. User notebook.
- Pan Aimin. The theory and application of COM. Beijing: Tsinghua University publishing, 1999.
- Lu Huiming, Zhu Yaochun. The standard communication agreement of controlling equipment-OPC Sever design. Beijing: mechanical industry publishing, 2010.
- Bai Xiaolei. The research of wind power forecasting and AGC unit blend, Beijing Transportation University, 2009.
- Wang Huazhong. The design of SCADA. Beijing: Electronic industry publishing, 2010.
- Bouter, S, Malti, R, Fremont, H. Development of an HMI based on the OPC standard[J]. EAEEIE Annual Conference, 2008 19th.

IntechOpen

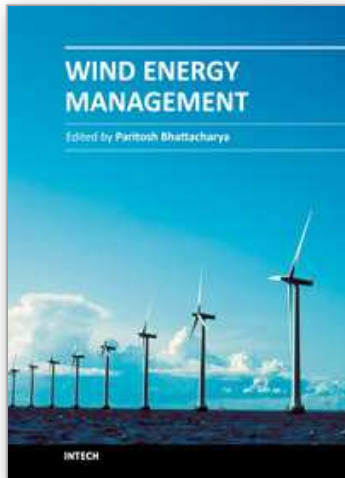

Wind Energy Management

Edited by Dr Paritosh Bhattacharya

ISBN 978-953-307-336-1

Hard cover, 128 pages

Publisher InTech

Published online 22, September, 2011

Published in print edition September, 2011

The book "Wind Energy Management" is a required part of pursuing research work in the field of Renewable Energy at most universities. It provides in-depth knowledge to the subject for the beginners and stimulates further interest in the topic. The salient features of this book include: - Strong coverage of key topics - User friendly and accessible presentation to make learning interesting as much as possible - Its approach is explanatory and language is lucid and communicable - Recent research papers are incorporated

How to reference

In order to correctly reference this scholarly work, feel free to copy and paste the following:

Yao Wanye and Yin Shi (2011). The Design and Implement of Wind Fans Remote Monitoring and Fault Predicting System, Wind Energy Management, Dr Paritosh Bhattacharya (Ed.), ISBN: 978-953-307-336-1, InTech, Available from: <http://www.intechopen.com/books/wind-energy-management/the-design-and-implement-of-wind-fans-remote-monitoring-and-fault-predicting-system>

INTECH
open science | open minds

InTech Europe

University Campus STeP Ri
Slavka Krautzeka 83/A
51000 Rijeka, Croatia
Phone: +385 (51) 770 447
Fax: +385 (51) 686 166
www.intechopen.com

InTech China

Unit 405, Office Block, Hotel Equatorial Shanghai
No.65, Yan An Road (West), Shanghai, 200040, China
中国上海市延安西路65号上海国际贵都大饭店办公楼405单元
Phone: +86-21-62489820
Fax: +86-21-62489821

© 2011 The Author(s). Licensee IntechOpen. This chapter is distributed under the terms of the [Creative Commons Attribution-NonCommercial-ShareAlike-3.0 License](#), which permits use, distribution and reproduction for non-commercial purposes, provided the original is properly cited and derivative works building on this content are distributed under the same license.

IntechOpen

IntechOpen