

We are IntechOpen, the world's leading publisher of Open Access books Built by scientists, for scientists

4,800

Open access books available

122,000

International authors and editors

135M

Downloads

Our authors are among the

154

Countries delivered to

TOP 1%

most cited scientists

12.2%

Contributors from top 500 universities



WEB OF SCIENCE™

Selection of our books indexed in the Book Citation Index
in Web of Science™ Core Collection (BKCI)

Interested in publishing with us?
Contact book.department@intechopen.com

Numbers displayed above are based on latest data collected.

For more information visit www.intechopen.com



Power Optimization of Energy Service Companies (ESCOs) in Peak Demand Period Based on Supply Chain Network

Aurobi Das¹ and V. Balakrishnan²

¹*Bureau of Energy Efficiency (BEE)-Ministry of Power, Govt. of India,*

²*Anna University of Technology,
India*

1. Introduction

A service value network may be defined as “the flexible, dynamic delivery of a service, and / or product, by a business and its networked, coordinated value chains (supply chains and demand chains working in harmony); such, that a value-adding and target-specific service and/ or product solution is effectively, and efficiently, delivered to the individual customers in a timely, physical or virtual manner.” This chapter has focused on the integration of renewable energy, specifically the solar energy resources into conventional electric grid and deployment of smart architecture of hybrid energy system in the context of Green House Effect to Climate Change with the deployment of energy conservation efforts by Energy Service Companies (ESCOs) under Energy Conservation Act 2001 under Bureau of Energy Efficiency (BEE) in Indian context for sustainable development of the rural and urban sector. A proposed research background for cost proposition for integrating distributed renewable –solar energy resources to the electricity grid is discussed.

ESCOs (Energy Service Companies), and ESCOs groups and ESCOs chains or e-energy service companies in the Smart-Grid network can optimize the national power shortage problem in peak demand period. It is a virtual service value network based on supply chain network of various energy trading companies. This proposition also helps to minimize the adverse challenges of climate change utilizing renewable energy resources at this service value network integrating into repository of conventional energy resources, thus reducing CO₂ emissions percentage and ultimately enhancing a green power scenario. The deployment of smart architecture of hybrid energy system for sustainable development of the rural and urban sector through the integrated renewable energy, specifically the solar energy resources into conventional electric grid with the concept of next generation mobile smart-grid city for efficient real-time collaborative use of renewable and non-renewable energy sources at smart user-centric device for sustainable green environment in the context of climate change proposition, which with the chain of ESCOs can reduce CO₂ emission ultimately with synchronization of all entities in the virtual network of Smart-Energy scenario. The cost proposition for integrating distributed renewable –solar energy resources to the electricity grid has been analyzed.

This chapter illustrates the deployment of Energy Portal (EP) for Renewable Energy Resources based on Service-Oriented-Architecture (SOA) technology. This EP based on Business Information Warehouse, will be utilized as Decision Support System for Energy Service Companies (ESCOs) and the Energy Information System Manager as well as the Enterprise Management System in the peak load time to utilize renewable energy resources to reduce power failure, to take decision about resource utilization of renewable energy resources in present global scenario of creating a pollution free environment based on Kyoto Protocol (The Kyoto Protocol is a protocol to the United Nations Framework Convention on Climate Change (UNFCCC or FCCC), an international environmental treaty with the goal of achieving "stabilization of greenhouse gas concentrations in the atmosphere at a level that would prevent dangerous anthropogenic interference with the climate system"). Also utilization of SOA for renewable hybrid energy systems to be connected to the National Power Grid, and also Grid-Interactive Solar Energy System or Solar-Wind integrated System, which may be distributed but can be mapped for feeding into the National Electricity Grid through proper deployment of SOA has been analyzed through case studies.

2. Energy conservation act 2001 & its salient features in the context of India

The Act empowers the Central Government and, in some instances, State Governments to: (i) specify energy consumption standards for notified equipment and appliances; (ii) direct mandatory display of label on notified equipment and appliances; (iii) prohibit manufacture, sale, purchase and import of notified equipment and appliances not conforming to energy consumption standards; (iv) notify energy intensive industries, other establishments, and commercial buildings as designated consumers; (v) establish and prescribe energy consumption norms and standards for designated consumers; (vi) prescribe energy conservation building codes for efficient use of energy and its conservation in new commercial buildings having a connected load of 500 kW or a contract demand of 600 kVA and above; (vii) direct designated consumers to – (a) designate or appoint certified energy manager in charge of activities for efficient use of energy and its conservation; (b) get an energy audit conducted by an accredited energy auditor in the specified manner and interval of time; (c) furnish information with regard to energy consumed and action taken on the recommendation of the accredited energy auditor to the designed agency; (d) comply with energy consumption norms and standards; (e) prepare and implement schemes for efficient use of energy and its conservation if the prescribed energy consumption norms and standards are not fulfilled; (f) get energy audit of the building conducted by an accredited energy auditor in this specified manner and intervals of time. State government also is empowered by the act.

2.1 ESCOs in Indian context

ESCO (Energy Service Company) - A consultancy group engages in a performance based contract with a client firm to implement measures which reduce energy consumption and costs in a technically and financially viable manner.

The Government of India set up Bureau of Energy Efficiency (BEE) on 1st March 2002 [4] under the provisions of the Energy Conservation Act, 2001. The mission of the Bureau of Energy Efficiency is to assist in developing policies and strategies with a thrust on self-regulation and market principles, within the overall framework of the Energy Conservation

Act, 2001 with the primary objective of reducing energy intensity of the Indian economy. This will be achieved with active participation of all stakeholders, resulting in accelerated and sustained adoption of energy efficiency in all sectors. BEE is promoting energy efficiency measures in India under the Energy Conservation Act, 2001. BEE co-ordinates with designated consumers, designated agencies and other organizations and recognize, identify and utilize the existing resources and infrastructure, in performing the functions assigned to it under the Energy Conservation Act. The Energy Conservation Act provides for regulatory and promotional functions.

In addition to promoting energy audits among designated consumers by accredited energy auditors and facilitated by certified energy managers, BEE intends to promote implementation of energy conservation measures in existing buildings/ facilities through the ESCOs route. With a view to tap the potential of bringing about energy efficiency improvement in existing buildings/ facilities BEE had undertaken shortlisting of ESCOs through an open invitation and evaluation process. 35 ESCOs have been qualified. This database of shortlisted ESCOs has been shared by BEE with the State Governments/ State Designated Agencies (SDA) which in turn would help in taking up energy efficiency improvement projects in their existing buildings/ facilities.

There are several estimates of energy efficiency and conservation potential in the Indian economy. Most of them have based their assessment at the macro level taking note of some demonstration projects that were implemented in various sectors. Prominent amongst them are the Integrated Energy Policy (2006) that provides an estimate of energy saving potential in the Indian economic activity of 15-20%, the ADB study (2004) of Demand Side Management potential in industry, buildings, municipalities and the very recent National Mission for Enhanced Energy Efficiency that seeks to unlock a market potential of Rs. 74,000 crores and an avoided capacity addition of 19,000 MW. In this background, it is necessary to assess detailed potential in each sector and in each state, given that the implementation of the Energy Conservation Act, 2001 is with the State Governments through their notified State Designated Agencies (SDAs).

BEE, with the approval of Ministry of Power, has initiated a scheme for capacity building of SDAs during the current plan period. A 19 point state level Energy Conservation Action Plan (ECAP) has been evolved for 32 states/ UTs and is under implementation. As a part of the program, it was considered necessary to carry out a detailed assessment state-wise in some key sectors of the economy. National Productivity Council (NPC), an autonomous organization under the Ministry of Commerce, Government of India, was tasked to undertake this work in all 35 states / UTs. The study focused only on estimation of the total electricity consumption and saving potential in the following sectors of each state / UT: (i) Agricultural pumping; (ii) Municipal water and sewage pumping, street lighting; (iii) Commercial buildings like Hotel/ Resorts, Hospital, Shopping Mall/ Multiplex, office building, public park/ monument having connected load of more than 500 KW; (iv) Representative Small and Medium Enterprises (SMEs) which have high saving potential.

2.1.1 Policies to promote energy efficiency and renewable energy by BEE

(i) **Increased industrial energy efficiency:** In the major energy-consuming industrial sectors, such as cement, steel, aluminum, fertilizers, etc., average specific energy consumption has been declining because of energy conservation in existing units, and (much more) due to new capacity addition with state-of-the-art technology; (ii) **Electricity from renewables:** The Electricity Act, 2003, requires State Electricity Regulatory

Commissions to specify a percentage of electricity that the electricity distribution companies must procure from renewable sources. Several Commissions have already operationalized this mandate, and also notified preferential prices for electricity from renewables. This has contributed to an acceleration in renewable-electricity capacity addition, and over the past three years, about 2,000 MW of renewable-electricity capacity has been added in India every year, bringing the total installed renewable capacity to over 11,000 MW. Of this, a little over 7,000 MW is based on wind power. The National Hydro Energy Policy has resulted in the accelerated addition of hydropower in India, which is now over 35,000 MW; **(iii) Enhancing efficiency of power plants:** The Electricity Regulatory Commissions are also linking tariffs to efficiency enhancement, thus providing an incentive for renovation and modernization. New plants are being encouraged to adopt more efficient and clean coal technologies, and four new plants under construction have adopted the more-efficient supercritical technology for power generation[4]; **(iv) Introduction of labeling programme for appliances:** An energy labeling programme for appliances was launched in 2006, and comparative starbased labeling has been introduced for fluorescent tubelights, air conditioners, and distribution transformers, (See Fig. 1) providing information about the energy consumption of an appliance, and thus enable consumers to make informed decisions; **(v) Energy conservation building code:** An Energy Conservation Building Code (ECBC) was launched in May, 2007, which addresses the design of new, large commercial buildings to optimize the building's energy demand; **(vi) Energy audits of large industrial consumers:** In March 2007, the conduct of energy audits was made mandatory in large energy-consuming units in nine industrial sectors. These units, notified as "designated consumers" are also required to employ "certified energy managers", and report energy consumption and energy conservation data annually; **(vii) Accelerated introduction of clean energy technologies through the clean development mechanism (CDM):** Over 700 CDM projects have been approved by the CDM National Designated Authority, and about 300 of these have been registered by the CDM Executive Board, which have already resulted in over 27 million tones of certified CO₂ emissions reductions, and directed investment in renewable energy and energy projects by reducing the perceived risks and uncertainties of these new technologies, thereby accelerating their adoption [4].



Fig. 1. Energy labels for refrigerators and fluorescent lamps

2.1.2 Literature review: The contribution of renewable energy to mitigate climate change-role of ESCOs in this issue

Changing smart energy scenario

Visions are: (i) “Use of advanced technologies to improve the performance of electric utility systems to address the needs of society.” (ii) “A fully automated power delivery network, ensuring a two-way flow of electricity and information between the power plant and appliance, and all points in between. Its distributed intelligence, coupled with broadband communications and automated control systems, enables real-time transactions and seamless interface among people, buildings, industrial plants, generation facilities and the electric network.” - U.S. Department of Energy Grid 2030. (iii) “Its foundation is new distributed data communication, computing, and control technologies – efficient transfer of data and control from/ to/ among many field units.”

As stated in the Third assessment Report of the Intergovernmental Panel on Climate Change (IPCC), there is new and stranger evidence that most of the warming observed over the past 50 years is attributable to human activities, and that significant climate change would result if 21-st century energy needs were met without a major reduction in the carbon emissions of the global energy system during this century. Current CO₂ emission trends, if not controlled, will lead to more than a doubling of atmospheric concentrations before 2050, relative to pre-industrial levels[5]. Carbon dioxide, the most important anthropogenic greenhouse gas, increased markedly as a result of human activities, and its atmospheric concentration of 379 ppmv (parts per million, by volume) in 2005 by far exceeded the natural range of 180 to 300 ppmv over the last 650,000 years (CDIAC, 2005). This is being a serious challenge to sustainable development, the main strategies to prevent it are: (i) More efficient use of energy, especially at the point of end-use in buildings, transportation and production processes; (ii) increases reliance on renewable energy resources; (iii) accelerated development and deployment of new and advanced energy technologies, including next-generation fossil-fuel technologies that produce near zero harmful emissions. Due to lack of adequate investments on Transmission and distribution (T & D) works, the T & D losses have been consistently on the higher side, and are presently in the range of 22-23 %. Solar energy has immense potential as the amount of solar radiation intercepted by the earth is much higher than the annual global energy use. Large-scale availability of solar energy depends on a region’s geographic position, typical weather conditions and land availability. Also the amount of final energy will depend on the efficiency of conversion device used (such as the photovoltaic cell applied). Implications of renewable energy resources are manifold towards climate change reducing CO₂ emissions, reducing T & D losses by substituting conventional resources, ultimately affecting overall economy of hybrid energy system. The appropriate break-up of T & D losses in the Indian Power System are as follows:

Transmission Loses	
(400 kV, 220 kV, 132 kV, 66 kV)	4 %
Distribution Losses	
(33 kV, 11k V and 400 volts)	19 %
	<hr style="width: 100%; border: 0.5px solid black; margin-bottom: 5px;"/> 23 %

Out of the above losses 19% at distribution level, non-technical commercial losses account for about 5%, and thus the technical losses in distribution system may be taken as about 14%.

PV connected to the electrical system (domestic and small scale)

Mains connection means that the grid provides a reserve when output from the PV panels is not available. As well as acting as a source of electricity in the absence of PV output, the grid can also accept spill or surplus electricity generation when the connected load cannot accept any further power from the PV modules. This is particularly useful when the panels are producing electricity, with little or no available load.

The grid can absorb PV power that is surplus to requirements very much in the manner of a giant battery that is being charged. This excess (or spilled) electricity flows to the grid and will automatically replace fossil fuel-generated electricity from the power stations. The PV electricity generated carries the additional benefit that it is supplied locally to customers and saves the electrical losses that occur in the grid transmission and distribution system (as the electricity flows through transformers, wires and cables from the power station). Grid-connected systems such as solar PV are described as network or grid embedded generation.

In grid-connected PV systems, the DC output voltage from an array requires to be converted to a voltage and frequency that can be accepted by the grid, which is done using a grid-commutated inverter, which makes sure there is synchronization between the PV electrical output and the electricity mains. The excess electricity not used within the buildings can be exported to the network and credited, with the agreement of the local electricity distribution network operator (DNO) or energy supply company (ESCO). The rate paid for spilled electricity will very much depend on the spill payment offered by the ESCO. Suitable certified and approved meters are installed to measure the amount of electricity generated by the system (generation meter) and spill onto the grid (export meter).

Under some arrangements, payment is made for the spilled electricity as well as the environmental credit or greenness of the electricity generated by the PV system. The PV generation meter will register all the electricity generated by the panels. In some areas the ESCOs are considering the introduction of net metering systems. In this arrangement imported electricity is supplied and charged at the normal tariff rate for the installations, but exported electricity is deducted from the imported total and the installation is billed for the net balance between the import and exported electricity. It may be possible to have a net export of electricity with a payment for the exported balance from the ESCO, which is analogous to the energy company's main import meters running backwards during export.

2.1.3 Proposed research in renewable energy resources-solar energy to develop a smart energy scenario to cut CO₂ emissions

Energy produced from renewable energy resources such as solar specifically for example, is stored in battery before consumption, which is a solar module, which will be able to supply energy uninterrupted. The main advantage of the system is that energy production's independence from electricity network. The proposed research is to investigate solar irradiance in a particular location and to build solar module at that location of maximum irradiance and to measure the solar energy produced and simultaneously send that estimated solar energy to a computer through wireless connection or cable. The system will

be able to monitor specific types of investments that can be recommended for renewable energy resources are: (i) By expanded use of renewable energy resources for example PVs for small-scale applications in high-insolation areas can reduce the T & D losses of conventional energy resources; (ii) Use of PVs to provide supplementary power on grid-connected distribution systems, if the peak load matches solar insolation; (iii) To analysis the cost proposition for integrating distributed renewable –solar energy resources to the electricity grid; (iv) Deploy a Service Value Network for ESCOs in the Smart-Grid infrastructure of Hybrid Energy Systems of integrated renewable energy recourses to the electricity grid.

2.1.4 The “smart grid” applications

Grid-connected applications: There are two main options for feeding PV electricity into grid network: (i) Via large central power stations occupying many areas of lands; (ii) Via many small grid-connected systems distributed on the roofs of the buildings. **Centralized PV power stations:** Large-scale PV plants connected to the grid will have to compete with conventional sources of grid electricity, to become commercially viable to substitute the expensive peak-load power plants. This commercial grid-connected applications of PV is cost-effective in the peak-demand period. Specific Energy Systems Models is a linear programming type model that find the optimum combination of generators for a given electricity demand (characterized by a load-duration curve) and a given set of environmental restrictions. In case of a growth of demand in the electricity network, the capacity in the network should be increased. This increase of demand leads to an increase of peak load in the system, where this additional load will have to be supplied 100 % by additional plants. Assuming that renewable energy generators could take over some part of this capacity expansion, where some of the additional energy demanded can be supplied by the renewable energy resources. If the additional peak demand, for example, is solar driven, it may be possible that the demand will occur at times when the availability of this system is particularly high.

2.1.5 Prism analysis of EPRI in the context of CO₂ reduction in smart-grid scenario

As per analysis, a Smart Grid could potentially reduce annual energy consumption by 56 to 203 billion kWh in 2030, corresponding to a 1.2 to 4.3% reduction in projected retail electricity sales in 2030 [3]. In addition, a Smart Grid can facilitate greater integration of renewable generation resources and greater deployment of plug-in hybrid electric vehicles (PHEVs). Both of these mechanisms, while not associated with energy savings, will reduce greenhouse gas emissions, insofar as (a) renewables such as wind and solar displace fossil-burning energy sources and (b) PHEVs avoid emissions from conventional internal combustion engines in the transportation sector. **The combined environmental impact of these seven Smart Grid mechanisms is an estimated annual reduction in greenhouse gas emissions equivalent to 60 to 211 million metric tons of CO₂ in 2030.** As per Prism analysis of Electric Power Research Institute (EPRI), the U.S. electricity sector will need to rely on a portfolio of technologies to meet future carbon reduction goals, including energy efficiency, renewables, nuclear, advanced coal, carbon capture and storage, plug-in hybrid electric vehicles, and distributed energy resources. The EPRI Prism chart, shown as Fig. 2, illustrates what most industry experts agree: energy efficiency – the top slice of the Prism shown in blue – is the most technically and economically viable near-term option for the

electric power industry to reduce its carbon footprint [1]. As per view of EPRI, an integrated set of four building blocks constitutes an emerging infrastructure that can make energy efficiency more dynamic and robust over time, substantially expanding its potential [2], which are: (i) **Communications infrastructure** to allow bi-directional flow of information between electricity suppliers and consumers; (ii) **Innovative rates and regulation** to provide adequate incentives for energy efficiency; (iii) investments for electricity suppliers and consumers. This can encompass the promulgation of innovative retail rate design structures such as time-of-use or dynamic pricing, which provide electricity customers with rates that correspond to wholesale market conditions. It also includes regulatory structures that encourage utilities to pursue energy efficiency, such as shareholder incentive mechanisms; (iv) **Smart end-use devices** that are energy-efficient and able to receive and respond to real-time signals; (v) **Innovative markets** to ensure that energy efficiency measures instituted by regulation become self-sustaining in the marketplace. This can encompass the promulgation of progressive energy efficiency programs – implemented by utilities, state agencies, or other entities – and codes and standards that transform the market for energy efficient products and services.

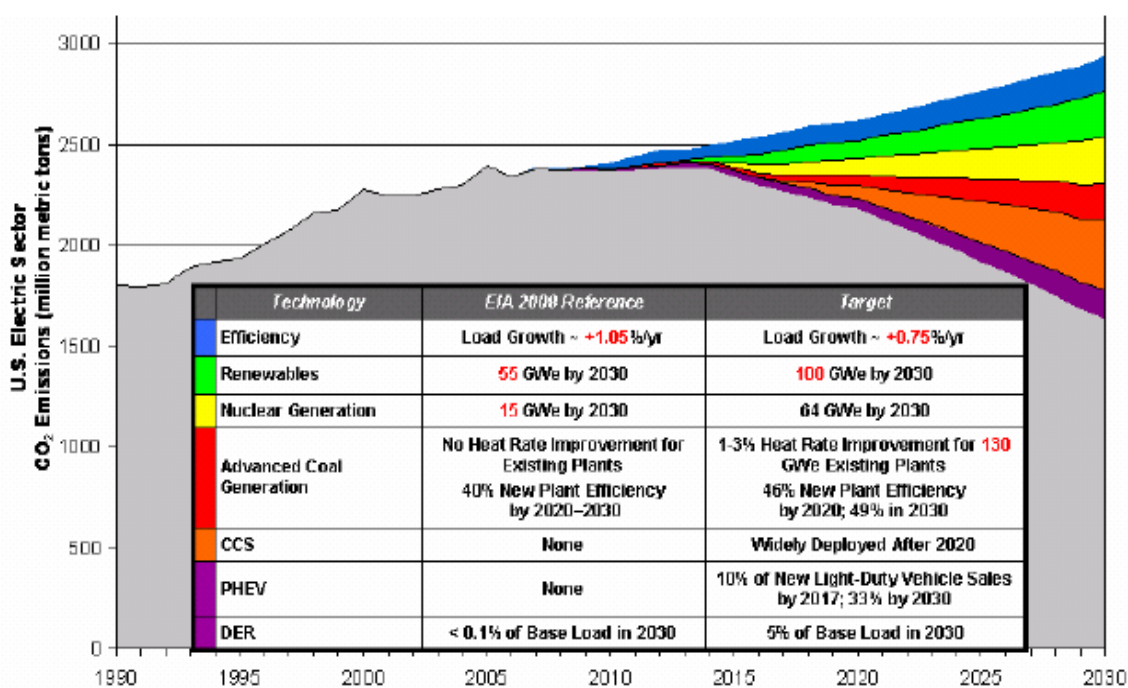

Fig. 2. EPRI 2008 Prism – technical potential for CO₂ reductions in US electric sector

From a utility's perspective, a Smart Grid can be viewed as a means to further five primary Goals such as: (i) Enhance Customer Service; (ii) Improve Operational Efficiency; (iii) Enhance Demand Response and Load Control; (iv) Transform Customer Energy Use Behavior; and (v) Support More Utility Energy Efficiency Investment (See Fig. 3). As demonstrated in the Fig. 4, some of the energy savings and carbon reduction benefits overlap across the various goals. For example, indirect feedback to customers via improved billing is related to improvements in operational efficiency and to transforming customer energy use behavior. In addition, greater options for dynamic pricing and demand response are related to enhancing customer service as well as to enhancing demand response [2].

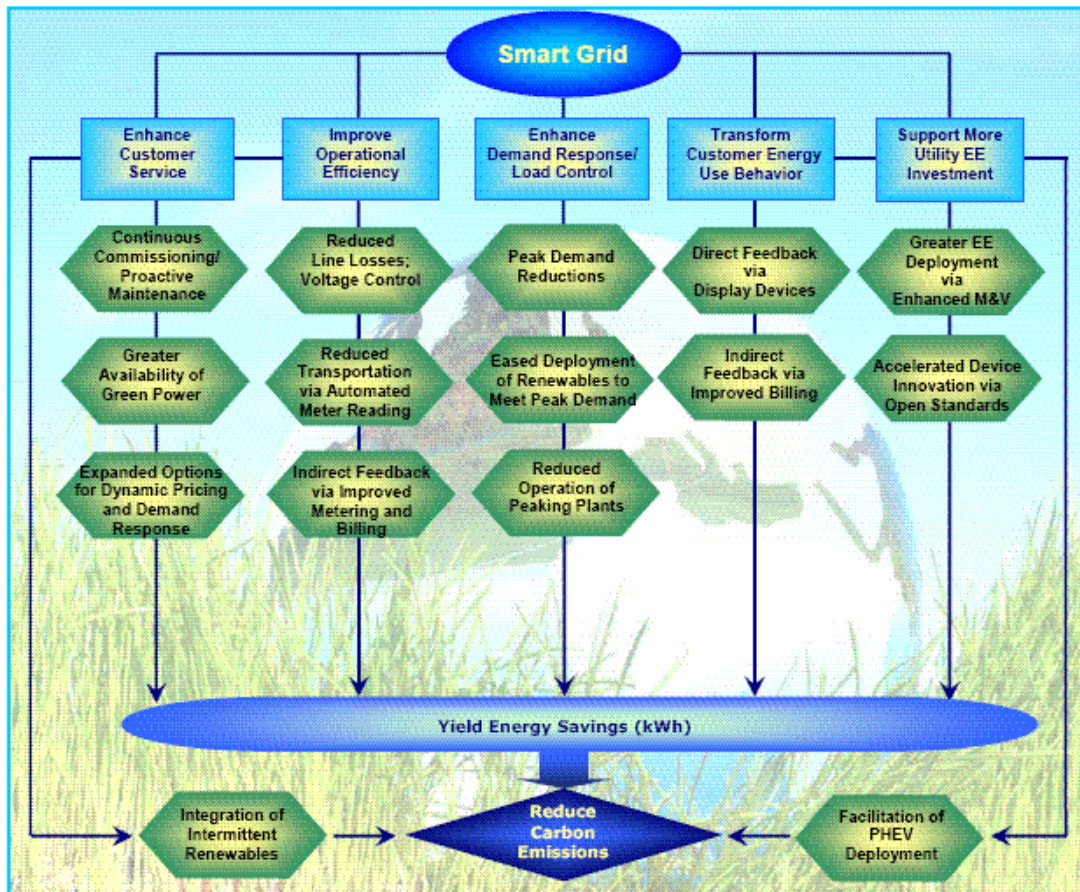

Fig. 3. Utility smart grid goals: All paths lead to carbon reductions

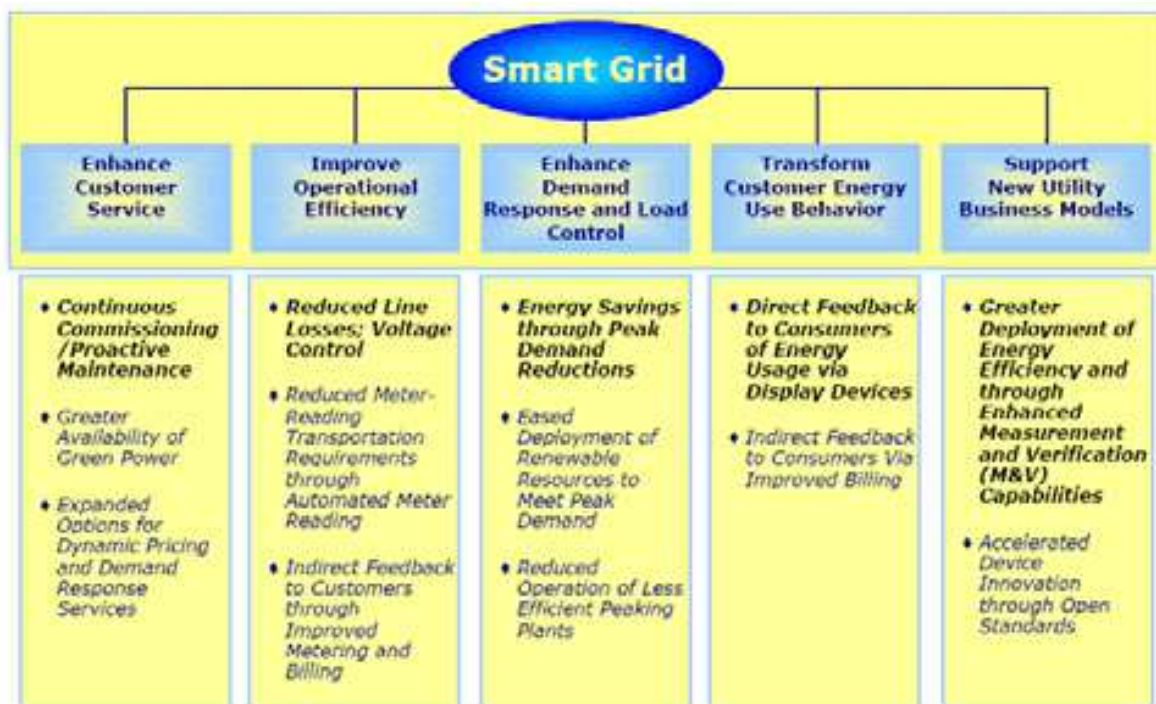

Fig. 4. Summary of energy-savings & carbon-reduction mechanisms enabled by a smart grid

2.1.6 Proposed methodology

(a) **To identify the break-even point for integration;** (b) **Technology upgradation:** (i) **Creation of a Standardized Interface and testing of that interface regarding hybrid energy system integration;** (ii) **Usage of A high-voltage, direct current (HVDC) electric power transmission system:** HVDC uses direct current for the bulk transmission of electrical power, in contrast with the more common alternating current systems. Also, for long-distance distribution, HVDC systems are less expensive and suffer lower electrical losses. Hence usage of HVDC in the context of renewable energy integration to electricity grid and vice-versa is proposed; (iii) **Super conductor research:** This is encouraged as transmission loss is reduced while transmission through super conductor and hence this research in the context of renewable energy integration to electricity grid and vice-versa is proposed; (c) **Incorporating NASA Surface Meteorology and Solar Energy Data on Solar Energy Resources to estimate the solar energy potential at a particular latitude and longitude [7];** (d) **Select Renewable Energy and Energy Efficient Systems (REEESs) whose market potential is to be mapped.** Priority to be given to systems which are more promising for large scale application but present utilization is far below the potential; (e) **Identification of all relevant factors affecting the market potential or acceptance level for any new REEESs under consideration;** (f) **Assess the significance level of each identified factor for the specific cases and assign the multiplication factor considering their availability, local, social and environmental conditions. Thus develop a scientific, elaborative, convenient and yet practically applicable method to calculate the Acceptance Index (AD)[7];** (g) **Collection of relevant primary data from representative number of locations distributed over the geographic region, viz. the North Eastern Region of India. Test the kit with primary data so obtained for statistically representative locations. Make necessary modifications.**

2.1.7 Cost proposition for integrating distributed renewables-solar energy resources to electricity grid

1. Cost of renewable energy at the point of demand

Cost of Renewable Energy at the point of Demand = Installation Cost + Transmission Cost
Where Installation Cost = Efficiency of the System + Area of the System

2. Cost of extension of grid to point of generation of solar energy

On the Map nearest Grid Point has to be located
System Cost + Extension of Grid to the Point of Generation
= Fixed Cost + Variable Cost + Energy Transmission Loss + Generation Efficiency + Installation Cost [Transmission line gap fill-up cost]

3. Social cost

Market price of conventional energy resources

Conventional Power Generation Cost + profit + social cost = Market Price (MP)

Market price of non conventional energy resources-renewable

Non Conventional Power Generation Cost + Profit – Social Benefits = Market Price (MP)

Environmental costs: Conventional power generation creates 'Social Costs' which are not included in the price of electricity. These social costs include damage done to the environment by acid rain and global warming, and effects on human health due to toxic emissions such as sulphurous and nitrous oxides.

Market price will then be set on equal plane if social cost of conventional energy resources can be given as subsidies to non conventional energy resources to replace conventional energy resources with non conventional –renewable energy resources. In this scenario, real completion of renewable is possible with conventional and renewable energy resources can compete farley with conventional energy resources.

2.1.8 Challenges faced by power companies and ESCOs

Environmental legislation in most industrialized countries calls for an increase in the production of renewable energy. The decentralized nature of facilities that produce green energy (solar energy), where **Green Energy or Sustainable Energy**-is the energy already passing through the environment as a current or flow, irrespective of there being a device to intercept and harness this power; compounded by natural fluctuations in power output, make it difficult for a power company to gather, validate, and deliver power-capacity data. Hence, estimation of reasonably accurate capacity forecasts is a greater challenge along with the changes in government policies that result in changes to subsidies and tax breaks granted to producers of green energy. Enterprise services into composite application of mainstream power business enable a power company to reliably gather green-energy data from disparate sources and to embrace change in the fast-moving green-energy part of its business. A power company needs timely information on its current and anticipated future capacities of green energy – a task that is extremely difficult to fulfill with error-prone manual and semiautomatic methods. Data sources typically include standard software solutions and a number of non-standard applications plus nonstandard databases run by the company's smaller suppliers of green energy. They may even include arrays of solar panels operated by individuals who merely have a separate electricity meter that relays data to the power company in real time. Collecting complex data from disparate sources such as these and then aggregating and validating all relevant data requires a tremendous amount of effort plus time-consuming communication. Also green energy is popular; a growing number of customers are prepared to pay a premium for "clean" power. To sharpen its competitive edge in a highly competitive and sometimes volatile market, a power company wants to deploy a solution designed to ensure the quality and currency of data; to automate the tasks of data gathering, aggregation, validation, and presentation; and to ensure sustained regulatory compliance [7]. Supply Chain Network of ESCOs should be integrated with the Network of energy trading Companies in Smart-Grid of hybrid energy system with the implications of treating energy trading companies as ESCOs.

2.1.9 SOA basic concepts

Service Oriented Architecture (SOA) is a business-centric IT architectural approach that supports integrating the business as linked, repeatable business tasks or services. SOA helps users build composite applications which draw upon functionality from multiple sources within and beyond the enterprise to support horizontal business processes. A composite application is a set of related and integrated services that support a business process built on SOA. As a gross generalization, a service is a repeatable task within a business process. Identification of business processes and then identification of set of tasks within that each process. Next tasks are defined as services and the business process is a composite of

services. The Service Oriented Modeling and Analysis (SOMA) technique is an approach which has been devised to help to identify the appropriate granularity and construction of services derived from the business design. Service orientation is a way of integrating the business as a set of linked services. A Service Oriented Architecture, then, is an architectural style for creating an enterprise IT architecture that exploits the principles of service orientation to achieve a tighter relationship between the business and the information systems that support the business. Finally, SOA-based enterprise architecture will yield composite applications. A Service Oriented Architecture (SOA) is set of principles that define an architecture that is loosely coupled and comprised of service providers and service consumers that interact according to a negotiated contract or interface. These services provide the interfaces to Applications in the IT landscape. The primary goal of SOA is to expose application functions in a standardized way so that they can be leveraged across multiple projects. This approach greatly reduces the time, effort and cost it takes to maintain and expand solutions to meet business needs [12].

2.1.10 Role of enterprise service bus (ESB) in SOA configuration

ESB provides a comprehensive, scalable way to connect a large number of applications without the need for each pair of applications to make a direct connection. Such a direct connection between two applications is called a *point-to-point connection*. In Web Services, the connection between the service consumer application and the service provider application is “point to point”. The point-to-point connection approach does not scale well because the number of applications involved in the integration increase; therefore, this integration approach is not suitable for a large enterprise where a large number of applications need to be integrated. The features of ESB are as: (i) An enterprise service bus (ESB) is the infrastructure of SOA; (ii) Its purpose is to provide interoperability (connectivity, data mapping, and routing) combined with some additional services such as security, monitoring, and so on; (iii) An ESB can be heterogeneous. Basic Services are services that each provide a basic business functionality, which provide the first fundamental business layer for one specific backend or problem domain. The role of these services is to wrap a backend or problem domain so that consumers (and high-level services) can access the backend by using the common SOA infrastructure. Hence, by introducing basic services, we get the fundamental SOA. With basic services introduced, service consumers can use an ESB to process the business functionality that one back end is responsible.

2.1.11 Business problems addressed by SOA

A large organization typically has many relationships with external business entities such as business partner and suppliers. These relationships are fluid in nature and frequently change for which a new approach is required to meet these fast-changing business conditions to provide flexible, agile IT systems that could meet these fast-changing business needs of the time. SOA answer the problem with an emphasis on agile IT system through the use of reusable components. In this architecture, computer programs or components developed instead of solving a specific business problem, provide some generic functionality, where these component can be threaded, linked, or integrated in a specific order or configuration to meet a specific business need. If the business requirement changes, there is no need to develop a new computer program and the system can be reconfigured to

meet the new business requirement. Generally, the different kinds of technological heterogeneity exist in a large enterprise, which are as following: (i) Middleware heterogeneity: Generally in a large enterprise, more than one type of middleware is being used and two not common types of them are application servers and message-oriented middleware (MOM);(ii) Protocol heterogeneity: This heterogeneity refers to the different transport protocols being used to access the services offered by various applications; (iii) Synchrony heterogeneity: There is always a need to support both synchronous and asynchronous interactions between applications, which leads to a situation where the types of interaction supported by the two applications that wish to interact do not match; (iv) Diversity of data formats: Most of the time the data is dependent on the middleware being used, also can cause a problem if two applications that wish to interact support different data formats; Diversity of interface declarations: There are large difference in the way the service interfaces are declared and used to invoke a service; No common place for service lookup: Sometime there are no common place to look up services to deal with the diversity of services in a large enterprise.

2.1.12 SOA-energy portal (EP)

Creating a SOA-EP onto a Smart Device for power generation, transmission and distribution companies and Energy Service Companies (ESCOs) will help to reference real-time data related to power generation, transmission and distribution and peak load scenario of different utility consumers from diverse sources; for which SOA-EP features a unification server. This unification server includes a collaboration component, supporting real-time collaboration among various ESCOs and power plants at different sites via virtual rooms and different collaboration tools. Also the supply chain capabilities of individual supply chain members of various renewable and nonrenewable energy sources are brought together through mapping of Supply Chain Configuration Framework for renewable and nonrenewable Energy sources to enable joint decision making and technological implementation of decisions. Cross-enterprise functionality of State Grid with the remote renewable energy sites and nonrenewable energy sites has to be efficiently shared information cross all the departments and power generation plants and transmission and distribution network and also to work seamlessly with ESCOs and suppliers and communicate easily with industrial and domestic energy customers. This state grid can interact with entities outside it i.e. can integrate with renewable and nonrenewable energy sources i.e. entities outside the boundaries of state grid and interaction has to be done to complete and succeed globally.

2.1.13 Solution through SOA

An intelligent electricity solution created on IBM's integrated, open-standards-based Service Oriented Architecture (SOA), connectgaia.com (Fig. 5) enables the Intelligent Grid work, to the advantage of all stakeholders – maintaining balance of electricity supply and demand in real time; allowing consumer participation in optimizing power and saving expenses through improved visibility; offering valuable demand response flexibility at relatively low cost. It will enable the creation of an intelligent power network that will pool dispersed and diverse resources and form a network that communicates and is in synergy with nature. The convergence of IT and Power Highway, the birth of an intelligent grid, that is alert, smart and communicates end to end.

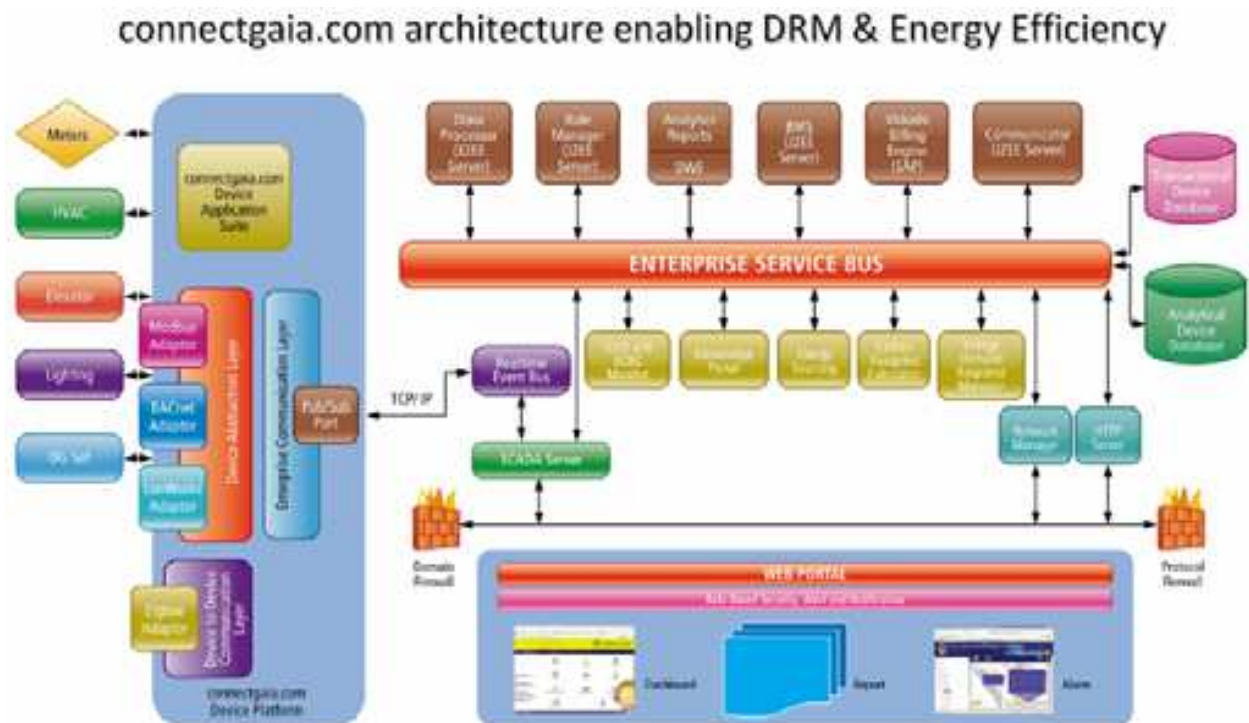

Fig. 5. Connectgaia.com architecture enabling Demand Response Module (DRM) & Energy

3. Conclusions

A smart-energy market where an integrated renewable energy system into the smart-grid –a service oriented architecture can be designed to assess market potential of conventional versus renewable via acceptance index which is accessible to a mobile device or any smart device into a single entry point to the utility customer for efficient reliable use of energy resources in the context of environmental pollution control scenarios reducing Green House Gas (GHG) in the context of Kyoto Protocol for rural and urban sustainable development. In addition, 'Hybrid systems' also have enormous potential for remote areas. Wind turbines, possibly with additional solar resources, are used in conjunction with back-up diesel generators, which operate as required. The renewable sources typically supply 60-85 % of energy. Existing renewable energy systems and DG sets are not adequate to fulfill the actual demand of electricity at Sagar Island. Hence, more Solar Photovoltaic (SPV) and wind energy is required to be installed and which would be Grid-Connected via Eastern Regional Grid to form an unified Smart-Grid System, through which extra renewable energy after fulfilling the consumers demand of Sagar Island will be exported to the conventional National Grid and vice versa when there will be shortage of hybrid renewable energy sources to satisfy the needs of the customers of Sagar Island. Also intermittent supply of SPV and wind energy and other renewable sources should be fully utilized. Deployment of Service-Oriented-Architecture (SOA) will be based on the topology of this Hybrid Renewable Energy Systems and also Grid-Interactive Solar Energy System or Solar-Wind integrated System, which may be distributed but can be mapped for feeding into the National Electricity Grid through proper deployment of SOA.

A smart-energy market where an integrated hybrid energy system of renewables and conventional resources together, with the services of Energy Service Companies (EESCOs) can have impact to reduce CO₂ in the by replacing conventional with renewable. A Smart-

Grid scenario of integrated renewable energy system into the conventional electricity grid can be proposed and in this scenario, service value network of ESCOs in the Super Smart-Grid of Hybrid Energy System enabled with energy efficiency and energy conservation (ENCON) measures can optimize the demand for power in peak demand period to tackle the power failure synchronizing with the suitable location of insolation in case of electricity driven by solar energy resources as for example. A cost proposition of renewable energy resources can have impact to substitute conventional energy resources in the peak load scenario also thereby reducing T & D losses of conventional system ultimately. Supply Chain Network of ESCOs facing challenges which can be resolved by with the design and testing of common Grid standardized Interface for integrated operations of tapping solar, bio, wind energy resources. Renewables can be coupled with energy efficiency measures along with strong environmental measures to go hand-in-hand with economic and social benefits.

4. Case studies

Case study 1: Objective of the proposed sample project

The Energy Study in Selected Char Villages of Malda to set up a solar power plant to integrate it to the conventional electricity grid with the projected findings of current and future energy demand synchronized with the current and future population along with their growth rate percentage in 2009, 2011 and 2021 respectively.

Sample specifications and features of solar power system

NASA Surface Metrology and Solar Energy Data for Solar Energy Resources is used to find out the exact solar radiation estimation at a particular latitude & longitude of the Malda District of West Bengal. A proposed research background is discussed with an Energy Optimization Model for accessing Market Potential Mappings (MPMs) of solar energy resources specifically through calculating Acceptance Index(AI) [7], [8], [9], [10], [11], considering socio-economic and environmental parameters of utility consumers utilizing NASA Solar Meteorology and Surface Energy Data in the context of East India as an experiment for application of pervasive computing technologies in energy & utility sector for sustainable rural and urban development in the era of future next generation smart-grid [7]. (See Appendix)

Case study 2: Objective of the proposed sample project

To set up reliable Hydro Power Supply System having dual sources of 3 kWe Aero Generator and 3 kWp PV Array for ensuring power supply operations.

Scope of work

The work involves: (a) timely procurement and transportation to site in properly packed condition of all equipment, materials and miscellaneous item required to complete the project; (b) design, manufacture, supply, installation, testing, commissioning and five years trouble free maintenance of two numbers Hybrid Power Supply System to be installed at two different schools under Sagar Block of South 24 Parganas District, West Bengal.

Sample specifications and features of wind-solar hybrid power system

The equipment and materials for Wind-Solar Hybrid Power Supply System shall include but not limited to the following: (a) Aero generator with blades, Gear driver train, shaft, Alternator and Yawing Mechanism; (b) Twisting cable, Tower Control Box with control switch; (c) Hinged type Tower with pin pole, if any; (d) Indoor JB and Control Switch; (e) Guy ropes

and Guy anchors; (f) Aero Generator Isolating Switch' (g) PV Modules (Poly/ mono crystalline or Thin film); (h) Module Mounting Structures and frames; (i) Module Interconnecting Junction Boxes; (j) PV Array Isolating Switch; (k) Wind-Solar Hybrid Charge controller; (l) Battery Bank; (m) Battery Isolating Switch; (n) Inverter' (o) Inverter Isolating Switch; (p) AC Power Distribution Board; (q) Data Logger with all transducers for measurement of wind, solar, voltage, current, temperature etc.; (r) Cable & Wires; (s) Earthling system including Lighting & Surge Protection arrangement; (t) Civil works for foundation of Tower; (u) Civil foundation for Guy Anchors' (v) Civil work for Foundation of PV Array; (w) Tool Kits; (x) Users Manual; (y) Spares. All civil works associated with the installation and commissioning of Aero Generator System and PV Array shall have to be done by the Contractor.

Case analysis of Moushuni solar PV power plant

West Bengal Renewabl Development Agency (WBREDA) has set up a 53.5 kWp Solar PV Power Plant with an integrated daytime water supply system at village Bagdanga of Moushuni Island. Total population of this island is about 20,000. Primarily 300 families will be benefited with this Power Plant (See Fig. 12). Moushuni Island is a small picturesque island situated near Sagar Island and between Muriganga and Chinai rivers but very close to Bay of Bengal. *(A 20 kW Biomass Gasifier System is recommended to give back-up to this Hybrid Renewables System for a reliable electric supply during shortage of intermittent renewable like solar, wind)*

WBREDA in Eastern part of India is trying to electrify remote isolated islands through hybrid renewable energies. The proposition is to optimize that hybrid renewable energy plants of remote islands so that it can be grid-connected to feed the extra renewable after optimized use at those islands and vice versa. The aim isto design, develop and successfully deploy a modular solution for an existing renewable power plant operated by WBREDA, located at Moshuni Island, in Sundarbans of West Bengal, India.

Objective of the Project: Objective of the Project is (i) To Install Grid Interactive Operation of Hybrid Solar Photovoltaic (SPV), wind, bio-mass System at Moushuni Island; (ii) To ensure the reliability and efficiency of the system to optimize the utilization of the hybrid renewable energy sources; (iii) To design, fabricate and deply reliable power electronic front-end interface with modular hardware; (iv) This modular hardware is made indigenously for converting power output from multiple small-scale renewable energy sources and storage elements into usable voltage and frequency levels.

Problems: (i) The existing components in the existing system in Moushuni Islands for tapping sources like solar, biomass, wind etc. are not uniformly designed for integrated operation; (ii) Issues of maintenance, service and spares tend to reduce availability of theses power plants.

Solutions: All interfaces need to be on a common AC link, which also serves as the feeder to the loads. A universal interface for hybrid renewable energy sources with technology for integrated operation is required.

Technical Features are as follows (i) Maximum Power Point Tracking for wind electric generator (WEG) systems; (ii) MPPT for solar PV panels; (iii) Parallel operation of load side inverters; (iv) Parallel operation of battery chargers.

Input Side Features: The universal 10kW power electronic Basic Interface Module (BIM) with capability to interface with solar panels (variable current, DC), battery bank (fixed voltage, variable current, DC), wind generators (variable frequency, variable voltage AC), AC generator working from bio-mass(variable frequency, variable voltage AC) on the input side.

Output Side Features: The fixed frequency, fixed voltage AC link on the output side.

Control Algorithm: The control algorithm will ensure integrated operation of all the interface modules connected in parallel so as to feed a 20 kW load (Max.), to the feeder. Specific modules will be programmed with suitable control algorithms, which can be used to extract maximum power from a SPV source or WEG. A central controller is proposed to ensure the integrated operation of the power system and to realize user interface. (see Fig. 6).

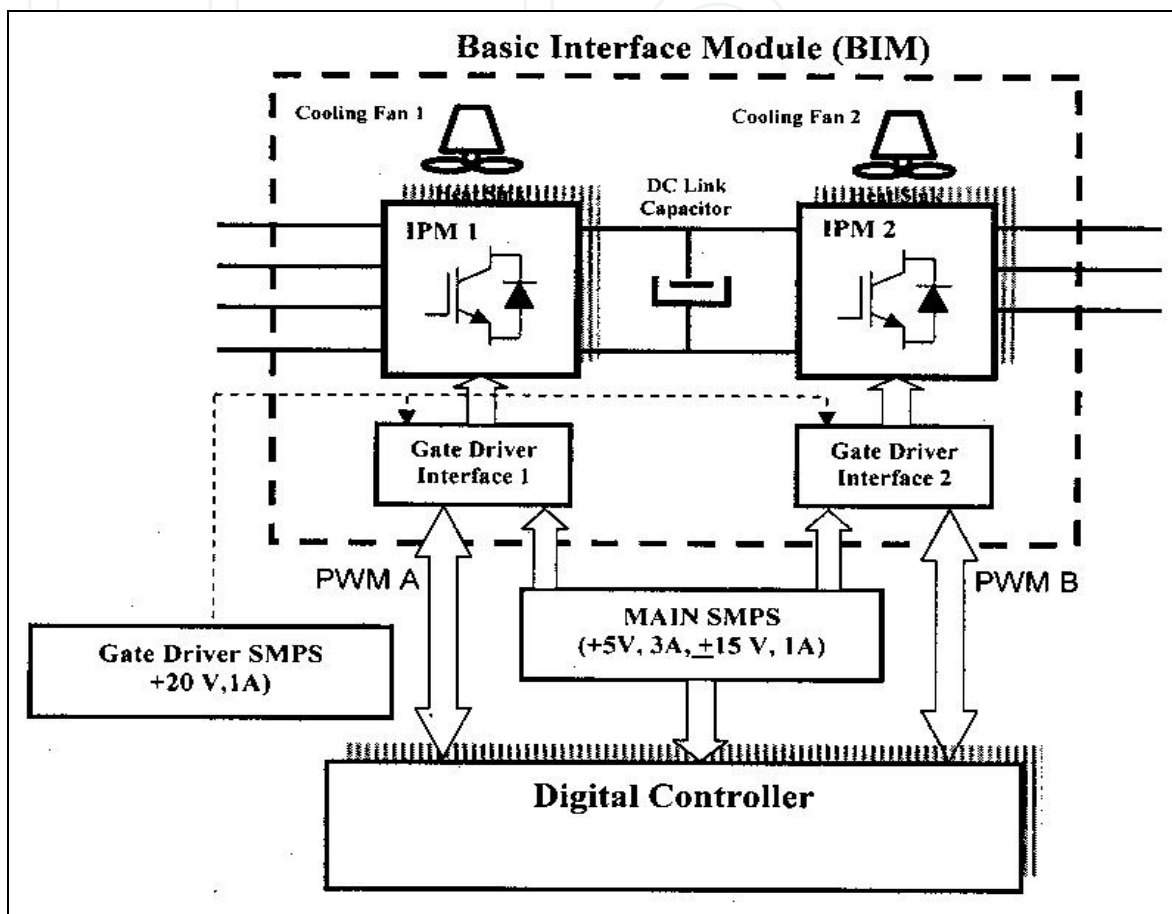

Fig. 6. Scheme of BIM and Digital Controller for Grid-Connected System at Moushuni Islands

Block diagram for BIM, digital controller proposed to be installed at Moushuni Island

Basic Interface Module (BIM): BIM is a back-to-back, three limb, two-level Voltage Source Inverter (VSI) topology sharing a common DC bus. This basic module can be customized through controls to fit the interfacing requirements of the known sources of renewable energy.

Topology for BIM: A four-wire topology needs to be used. As the BIM is proposed to have a three-limb topology, the four-wire AC output is to be realized through delta-star coupling transformers.

Fig. 7, 8 are the illustration for the Basic Interface Module (BIM) & Assembled and Tested units Proposed to be installed at Moushuni Island to control the solar-wind hybrid power plant for optimized use of renewable energy resources generated in the plant throughout the year to be grid-connected if required.

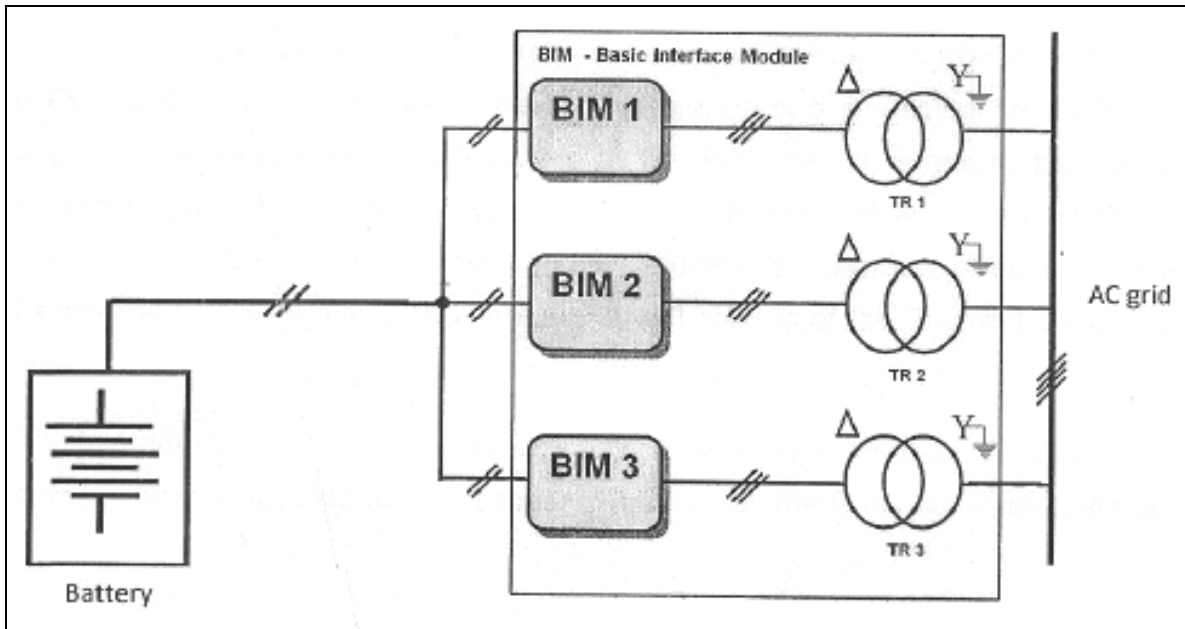

Fig. 7. BIM

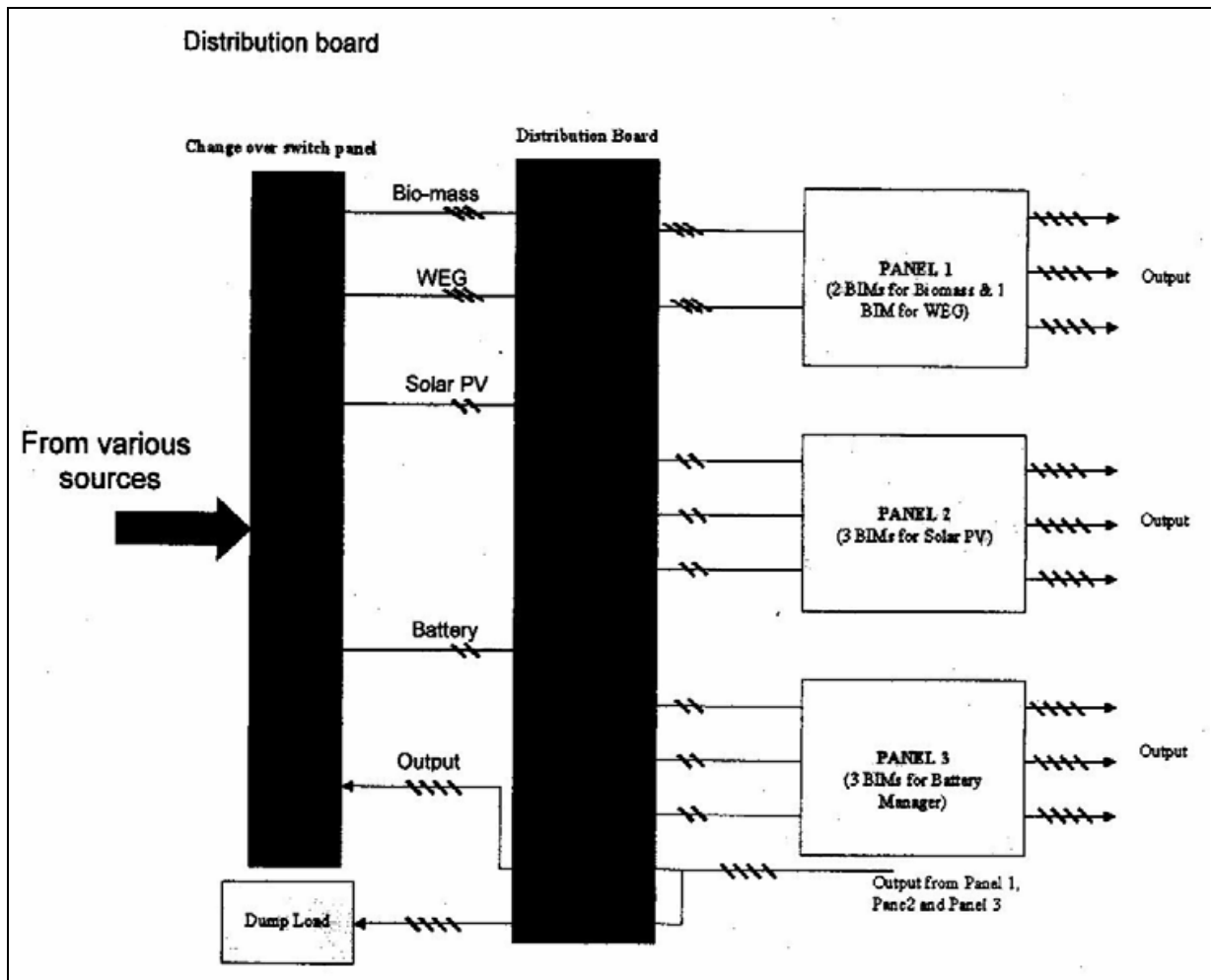

Fig. 8. Assembled and tested units at WBREDA- the illustration of the distribution board

Case analysis of energy scenario at Sagar Island

The island is separated from the mainland by Hooghly and Muriganga rivers and surface transportation is a major bottleneck for development of this area. The journey to Sagar Island from Calcutta involves 90 Km of road journey and 6 Km of boat journey (up to Kachuberia). The total length of black topped, semi metal and unpaved kutchha roads are 35 Km, 49 Km and 464 Km, respectively.

Problem Statements: (i) To reduce the generation cost by adding auxiliary sources of energy; (ii) To eradicate the barriers of non-reliability due to unpredictable availability of renewable energy sources, where wind is more unpredictable in nature than solar; (iii) Biomass is available during monsoon but contains lots of moisture which affects the system, but availability of wind is better in monsoon; (iv) There is no optimized operating zone.

Proposed main activities for the above two cases

(i) A Service-Oriented-Architecture (SOA) can be deployed for the proposed Hybrid Renewable Energy Systems integrating to the National Grid in Eastern Part of India, considering isolated Sundarban Islands, (here Sagar Island & Moushuni Island is considered) [7],[9],[10]; (ii) The similarity between the monthly availability of different renewable resources can be expressed in terms of correlation of hourly energy availability; (iii) Biomass supply chain should be maintained from energy security point of view; (iv) Diesel back-up must be maintained to cater demand in case of shortage of estimated renewable energy.

Decentralized solar energy for village electrification

The parameters for Green Grid in village electrification: The proposed methodology for the Green Grid in village electrification is considering following parameter such as: (a) Identification of parameters such as: (i) *Economic:* Cost of product, maintenance and operating cost, prevailing subsidy, tax benefits, benefit due to absence/ lesser amount (than fossil-fuel-run equivalent system) of social/ scarcity/ opportunity cost, resale value, etc. – all in annualized quantities; (ii) *Social:* Energy habit of the customer, social custom, aesthetic value of the product, customers goodwill for reasons such as lowering of pollution by use of these “green systems”, political goodwill/ propaganda, population density & accessibility of the location, grid connectivity, etc. and (iii) *Environmental:* Availability of solar radiation and other environmental conditions that would significantly affect the performance of the SPV system in consideration. (b) Quantification of each parameter should also take care of three levels of awareness of the target population, such as, **Willingness for Power- A: Very Willing; B: Somewhat Undecided; C: Unwilling. Also considering parameters (i) Totally un-aware; (ii) Aware but not yet totally realized; and (iii) Totally aware and realized.** (c) A reasonable time frame based on: (i) *Estimated product-life;* (ii) *The life of the technology;* and (iii) *Other factors (viz. the dynamic nature of the above mentioned parameters, the replacement frequency that depends on general habit of the users etc.)* **Also considering Supply Time-A: 24 Hour Supply; B: Fixed Time Supply; C: Any Time Supply** [see Appendix Table 6 & Table 7 for Sagar Islands for Commercial and domestic Consumers].

Case example of software utilization-SAP-APO for ESCOs

The SAP-Advance Planner & Optimizer (APO), the Supply Chain Management (SCM) initiative by SAP can be recommended in this Service Value Network of ESCOs to meet the challenges of managing the entire supply chain from end-to-end to meet the demand of utility consumers peak demand period as well as in power failure by ESCOs; because with

SAP-APO, SAP combined the ERP executing power of the SAP R/ 3 system with advanced data analysis [6].

5. Appendixes

Following is the surveyed and tested data for villages under Malda District of West Bengal, India for the project Specified in Case Study 1 with steps as: (i) Table 1 refers, to control the Market Price of Renewables in socio-economic [7] parameters using Algorithm of Acceptance Index(AI) [7], [8], [9], [10], [11]; (ii) Estimated Solar Radiation at a particular Latitude 25 and Longitude 87 provided as a sample at a particular point of the above mentioned Malda District along with, details of climate data at that location of earth throughout the year (See Table 2); (iii) Table 3: Socio-economic pattern of the same population of the above mentioned village; (iv) Table 4: Estimation of Latitude, Longitude, & Elevation in details for each block, gram panchayet under each village of the Malda – West Bengal-India; (v) Table 5: Projected population & energy demand by that population with growth rate percentage in details. Table 6 & Table 7: System Study for Modernization of Distributed Systems at Sagar islands –Load Demand Survey for Commercial & Domestic Consumers for respectively along with the parametes specified.

<p>Acceptance Index (AI)</p> $= \frac{\text{Life Cycle Cost of its Competing Conventional System}}{\text{Life Cycle Cost of Proposed System}}$ <p>Consider Solar Photo Voltaic (SPV) System as Proposed System & Coal Based Thermal Power Plant as Competing Conventional System</p> <p>Hence, AI of SPV System</p> $= \frac{\text{Life Cycle Cost of its Competing Conventional System}}{\text{Life Cycle Cost of Proposed SPV System}}$ $= \frac{\text{Life Cycle Cost of Coal Based Thermal Power Plant}}{\text{Life Cycle Cost of Proposed SPV System}}$ $\text{CRF} = \frac{d}{i - \left(\frac{i}{i+d}\right)^n}$ <p>Where CRF: Capital Recovery Factor d: Discount Rate n: Life in Number of Years i: Capital Investment</p> <p>Life Cycle Cost of Proposed SPV System=Fixed Cost X CRF + Maintenance Cost (Salary and Wages) + Fuel Cost (~0) – Cost of Power Sold – Subsidies</p> <p>Life Cycle Cost of Conventional Coal Based Thermal Power Plant = Fixed Cost X CRF + Maintenance + Fuel Cost + Social Cost –Cost of Power Sold</p>

Table 1. Algorithm for acceptance index [7], [8], [9], [10], [11]

Sample of NASA Surface Meteorology and Solar Energy Data for Northeast India-Malda District of West Bengal								
		Unit	Climate data location					
Latitude		°N	25					
Longitude		°E	87					
Elevation		m	37					
Heating design temperature		°C	12.70	NASA Surface meteorology and Solar Energy: RETScreen Data				
Cooling design temperature		°C	31.26					
Earth temperature amplitude		°C	15.95					
Frost days at site		day	0					
Month	Air temperature	Relative humidity	Daily solar radiation - horizontal	Atmospheric pressure	Wind speed	Earth temperature	Heating degree-days	Cooling degree-days
	°C	%	kWh/ m ² / d	kPa	m/ s	°C	°C-d	°C-d
January	17.6	47.9%	4.25	99.3	1.7	19.3	27	237
February	20.7	43.5%	5.30	99.1	2.1	23.5	2	302
March	25.1	40.4%	6.27	98.7	2.1	28.8	0	465
April	26.6	58.0%	6.70	98.4	2.6	29.8	0	499
May	26.6	76.8%	6.51	98.2	3.0	28.8	0	517
June	27.6	82.9%	5.39	97.8	2.9	28.9	0	527
July	27.4	85.7%	4.39	97.9	2.5	28.3	0	538
August	27.4	84.9%	4.44	98.0	2.1	28.1	0	539
September	26.3	84.3%	4.12	98.4	2.0	27.0	0	493
October	24.2	76.9%	4.86	98.8	1.6	24.9	0	450
November	21.6	57.5%	4.72	99.2	1.6	22.3	0	359
December	18.9	49.3%	4.17	99.4	1.6	20.1	7	284
Annual	24.2	65.7%	5.09	98.6	2.1	25.8	36	5210
Measured at (m)					10.0	0.0		

Table 2. Sample of climate data estimation of solar radiation [10], [11]

Village	name	Pancha- nandapur	Jamai Para	Peyari Pola	Mangadpur
Geographical Area	sq. km				
Gram Panchayet	name	Pancha- nandapur	Pancha- nandapur	Pancha- nandapur	Hamidpur
Population - Male	nos.				
Population - Female	nos.				
Population - Total	nos.	240	126	146	218
Population - School Going Children	nos.	80	36	46	35
Population - SC	nos.		126	101	95
Population - ST	nos.				
Population - Lit. Male	nos.	75	29	55	40
Population - Lit. Female	nos.	46	21	44	21
Population - Lit. Total	nos.	121	50	99	61
Population - Agri /lab	nos.	45	23	29	42
Population - Fishing	nos.	0	1	0	0
Population - Others	nos.	0	2	0	1
Population - Working Total	nos.	45	26	29	43
Total Income	rs.	59000	32700	38800	63700
No of Families	nos.	45	26	29	43
Avr. Income per Family	rs.	1311	1258	1377	1481
Average Monthly Fuel Requirement					
a) kerosene	litres	4.7	2.9	4.9	5.04
b) fuel wood	kg	115.5	85.3	93.1	172.5
No. of Points required					
a) Fan	nos.	55	47	30	71
b) Light	nos.	113	60	59	103
c) TV	nos.	18	19	3	34
Electrical Load					
a) Fan (@ 60 W each)	kw	3.3	1.9	1.2	2.84
b) Light	kw	11.3	6	5.9	10.3
c) TV	kw	4.3	4.5	0.72	8.16
d) Total	kw	18.9	12.4	7.82	21.3
e) Summer (3 Hrs/day for 6 months)	kwh/ month	9612	6696	4222.8	11502
f) Winter (3 Hrs/day for 6 months)	kwh/ month	9612	6696	4222.8	11502
h) Total (S:1602 ; W:1602)	kwh/ year	19224	13392	8445.6	23004

Table 3. Estimation of socio-economic parameters [11]

Block	Gram Panchayet	Char Village	NASA Surface Meteorology and Solar Energy Data		Elevation (ft)
			Latitude	Longitude	
Kaliachak-ii	hamidpur	harutola	24°55'01.45"N	88°01'20.86"E	93
Kaliachak-ii	hamidpur	khatiakana	24°55'17.99"N	88°02'45.23"E	69
Kaliachak-ii	hamidpur	mangadpur	24°57'08.45"N	87°57'15.32"E	97
Kaliachak-ii	hamidpur	janki sorkar	24°54'06.43"N	87°57'19.39"E	75
Kaliachak-ii	hamidpur	sripur	24°53'46.48"N	87°57'19.39"E	78
Kaliachak-ii	hamidpur	hallas tola	24°52'16.43"N	87°57'19.39"E	88
Kaliachak-ii	hamidpur	katlamary	24°51'26.53"N	87°57'19.39"E	85
Kaliachak-ii	hamidpur	jugal tola	24°55'01.40"N	87°52'15.37"E	92
Kaliachak-ii	panchanandapur	sibu tola	24°56'04.00"N	87°59'33.94"E	76
Kaliachak-ii	panchanandapur	jamai para	24°57'05.08"N	87°57'39.98"E	84
Kaliachak-ii	raj nagar	naya gram	24°55'08.27"N	87°51'11.45"E	75
Kaliachak-ii	raj nagar	charbabu pur	24°55'08.27"N	87°51'11.45"E	69
Kaliachak-ii	raj nagar	napitpara	24°55'01.41"N	87°52'12.47"E	97
Manikchak	dakshin chandipur	jitentola	24°03'47.50"N	87°53'12.36"E	95
Manikchak	dakshin chandipur	gudurtola	24°13'01.55"N	87°57'20.36"E	85
Manikchak	dakshin chandipur	raghunathtola	24°15'06.48"N	87°57'25.26"E	79
Manikchak	dakshin chandipur	aaikattola	24°55'01.45"N	87°57'12.36"E	81
Manikchak	dakshin chandipur	master tola	24°55'04.40"N	87°57'39.90"E	88
Manikchak	dakshin chandipur	jagabandhu	25°50'53.61"N	85°57'37.36"E	79
Manikchak	dakshin chandipur	jadutola	25°55'43.55"N	86°55'42.46"E	75
Manikchak	dakshin chandipur	raghu tola	25°51'41.50"N	87°56'47.26"E	81
Manikchak	dakshin chandipur	bhabani tola	24°00'42.74"N	87°57'88.06"E	84
Manikchak	dakshin chandipur	sadhucharantola	24°05'41.75"N	87°57'12.36"E	97
Manikchak	dakshin chandipur	samastipur	25°04'43.61"N	87°47'09.37"E	85
Manikchak	dakshin chandipur	paschimnarayanpur	25°12'58.50"N	87°48'40.51"E	82
Manikchak	dakshin chandipur	kartik tola	25°12'58.50"N	87°48'40.51"E	83
Manikchak	dakshin chandipur	chabilaltola	24°55'25.57"N	87°57'06.73"E	75
Manikchak	hiranandapur	sonar tola	24°49'26.38"N	87°58'13.61"E	90
Manikchak	hiranandapur	nathuram tola	24°55'01.45"N	87°57'12.36"E	76
Manikchak	hiranandapur	rekha tola	24°55'31.35"N	87°51'11.26"E	77
Manikchak	hiranandapur	lalmohan tola	24°55'21.55"N	87°58'42.66"E	78
Manikchak	hiranandapur	ramananda tola	24°55'31.35"N	87°52'32.46"E	94
Manikchak	hiranandapur	natun tola	24°52'22.45"N	87°50'13.66"E	85
Manikchak	hiranandapur	raghubirtola	24°51'07.45"N	87°51'17.76"E	87
Manikchak	hiranandapur	fulchand tola	25°11'56.40"N	87°55'16.39"E	79
Manikchak	hiranandapur	someswar tola	25°04'40.70"N	87°51'12.52"E	78
Manikchak	hiranandapur	sankar tola	24°55'01.35"N	87°57'12.36"E	87
Manikchak	hiranandapur	fuluktola	24°55'23.45"N	87°57'12.36"E	86
Manikchak	hiranandapur	amirchandtola	24°51'01.45"N	87°57'12.36"E	85
Manikchak	hiranandapur	bipin tola	24°45'01.34"N	87°51'08.26"E	83

Table 4. Estimation of latitude, longitude & elevations [10], [11]

MALDA DISTRICT OF W.B.-INDIA			POPULATION			ENERGY DEMAND (KW)				
BLOCK	GRAM PANCHAYET	CHAR VILLAGE	GROWTH RATE	2009	2011	2021	GROWTH RATE	2009	2011	2021
KALIACHAK-II	HAMIDPUR	HARUTOLA	2.58%	220	231.4984408	298.6585949	3.55%	17.58	18.8503352	26.71899443
KALIACHAK-II	HAMIDPUR	KHATIAKANA		316	332.5159422	428.9823454		20.02	21.46665021	30.4274328
KALIACHAK-II	HAMIDPUR	MANGADPUR		227	238.8643003	308.1613684		21.37	22.91420154	32.47923271
KALIACHAK-II	HAMIDPUR	JANKI SORKAR		222	233.6029721	301.3736731		13.13	14.07877708	19.95565398
KALIACHAK-II	HAMIDPUR	SRIPUR		211	222.02805	286.4407433		12.11	12.98507163	18.40540515
KALIACHAK-II	HAMIDPUR	HALLAS TOLA		174	183.0942214	236.2117978		10.11	10.84055113	15.36570158
KALIACHAK-II	HAMIDPUR	KATLAMARY		183	192.5646121	248.4296494		10.16	10.89416414	15.44169417
KALIACHAK-II	HAMIDPUR	JUGAL TOLA		284	298.8434418	385.5410953		19.01	20.38366735	28.89238249
KALIACHAK-II	PANCHANANDAPUR	SIBU TOLA		204	214.6621906	276.9379698		10.53	11.29090043	16.00403933
KALIACHAK-II	PANCHANANDAPUR	JAMAI PARA		122	128.3764081	165.6197663		10.75	11.52679769	16.33840672
KALIACHAK-II	RAJ NAGAR	NAYA GRAM		273	287.2685197	370.6081655		16.5	17.69229413	25.0775545
KALIACHAK-II	RAJ NAGAR	CHARBABU PUR		169	177.8328932	229.4241025		10.76	11.53752029	16.35360524
KALIACHAK-II	RAJ NAGAR	NAPITPARA		277	291.4775823	376.0383218		16.73	17.93891398	25.42712041
MANIKCHAK	DAKSHIN CHANDIPUR	JITENTOLA	2.05%	178	185.3728045	227.0785492	3.58%	14.71	15.78208892	22.43486977
MANIKCHAK	DAKSHIN CHANDIPUR	RAGHUNATHTOLA		309	321.7988573	394.1981557		24.29	26.06029504	37.04575029
MANIKCHAK	DAKSHIN CHANDIPUR	AAIKATTOLA		207	215.5739918	264.0744927		11.18	11.99481674	17.05111108
MANIKCHAK	DAKSHIN CHANDIPUR	MASTER TOLA		145	151.0059363	184.9797171		11.99	12.86385086	18.28647781
MANIKCHAK	DAKSHIN CHANDIPUR	JAGABANDHU		391	407.1933178	498.807375		27.17	29.15019416	41.43816531
MANIKCHAK	DAKSHIN CHANDIPUR	JADUTOLA		421	438.4379253	537.0790406		32.95	35.35145004	50.25349823
MANIKCHAK	DAKSHIN CHANDIPUR	RAGHU TOLA		157	163.5029793	200.2883833		8.93	9.580833045	13.61953685
MANIKCHAK	DAKSHIN CHANDIPUR	BHABANI TOLA		130	135.3846325	165.8438843		12.19	13.07842719	18.59150663
MANIKCHAK	DAKSHIN CHANDIPUR	SADHUCHARANTOLA		217	225.9881943	276.8317145		16.5	17.70254706	25.16487772
MANIKCHAK	DAKSHIN CHANDIPUR	SAMASTIPUR		339	353.0414648	432.4698213		23.03	24.70846417	35.12406872
MANIKCHAK	DAKSHIN CHANDIPUR	PASCHIMNARAYANPUR		344	358.248566	438.8484322		22.91	24.57971837	34.94105143
MANIKCHAK	DAKSHIN CHANDIPUR	KARTIK TOLA		232	241.609498	295.9675473		14.16	15.19200402	21.59604051
MANIKCHAK	DAKSHIN CHANDIPUR	CHABILALTOLA		283	294.7219308	361.0293788		20.97	22.49832799	31.98227186
MANIKCHAK	HIRANANDAPUR	SONAR TOLA		188	195.787007	239.8357711		9.84	10.55715534	15.00741798
MANIKCHAK	HIRANANDAPUR	NATHURAM TOLA		236	245.775179	301.0704361		13.35	14.32296989	20.36067379
MANIKCHAK	HIRANANDAPUR	REKHA TOLA		255	265.5621638	325.3091576		14.18	15.21346166	21.6265434
MANIKCHAK	HIRANANDAPUR	LALMOHAN TOLA		243	253.0651208	310.0004914		12.98	13.92600369	19.79637047
MANIKCHAK	HIRANANDAPUR	RAMANANDA TOLA		140	145.798835	178.6011061		6.75	7.24195107	10.2947227
MANIKCHAK	HIRANANDAPUR	NATUN TOLA		142	147.8816755	181.1525505		8.38	8.990748143	12.78070759
MANIKCHAK	HIRANANDAPUR	RAGHUBIRTOLA		157	163.5029793	200.2883833		8.93	9.580833045	13.61953685
MANIKCHAK	HIRANANDAPUR	FULCHAND TOLA		176	183.289964	224.5271049		9.23	9.902697537	14.07708008
MANIKCHAK	HIRANANDAPUR	SOMESWAR TOLA		192	199.952688	244.9386599		10.11	10.84683338	15.41920689
MANIKCHAK	HIRANANDAPUR	SANKAR TOLA		126	131.2189515	160.7409955		7.26	7.789120706	11.0725462
MANIKCHAK	HIRANANDAPUR	FUIUKTOLA		211	219.7396728	269.1773814		11.23	12.04846082	17.12736829
MANIKCHAK	HIRANANDAPUR	AMIRCHANDTOLA		254	264.5207435	324.0343454		16.54	17.74546233	25.22588348
MANIKCHAK	HIRANANDAPUR	BIPIN TOLA		231	240.5680778	294.6918251		12.32	13.2179018	18.78977536

Table 5. Projected population with growth rate & energy demand [10], [11]

Ref. Location	Rudra nagar Bazar Com.	Rudra nagar Bazar Com.	Rudra nagar Bazar Com.	Rudra nagar Bazar Com.	Rudra nagar Bazar Com.	Rudra nagar Bazar Com.
Name of Establishment	Pasu pati Das	Bhusan Ch. Maity	Bhava Sankar Pradhan	Barendra Nath Jana	Kali Pada Jana	Barendra Nath Mondal
Business Type	Shop	Shop	Shop	Shop	Shop	Shop
Source of Supply	W.B.S.E.B. (1X25 kVA Tr)	W.B.S.E.B. (1X25 kVA Tr)	W.B.S.E.B. (1X25 kVA Tr)	W.B.S.E.B. (1X25 kVA Tr)	W.B.S.E.B. (1X25 kVA Tr)	W.B.S.E.B. (1X25 kVA Tr)
Connected Load		2T+3B	2T+2B	5B	10T+2B	8T+3B
Light		2	1	-	2	2
Fan		-	-	-	-	-
TV		-	-	-	-	-
Freezes		1X5A Plug	2X5A	1X5A	1X5A	1X5A
Others					1X1.5Kw Motor	
Total Load in kW	0.6	0.58	0.54	0.48	2.86	0.88
Demand Load in kW	0.3	0.39	0.29	0.31	0.89	0.63
Willingness for Power A: Very Willing B: Somewhat Undecided C: Unwilling		A	A	A	A	A
Preferred Supply Time A: 24 Hour Supply B: Fixed Time Supply C: Any Time Supply		A	A	A	A	A
Possible of Expansion of Business with Increased Availability of Power		Yes	Yes	Yes	Yes	Yes

Table 6. System Study for Modernization of Distributed Systems at Sagar Islands –Load Demand Survey for Commercial Consumers [13]

Features of Systems Study as per Table 6 are as below:

Type of the Load: Commercial

Reference Location: Rudranagar Bazar

Source of Supply: (1X25kVA Tr) by West Bengal State Electricity Board (WBSEB)

Parameters Considered: Willingness for Power

A: Very Willing ; B: Somewhat Undecided; C: Unwilling

Preferred Supply Time

A: 24 Hour Supply; B: Fixed Time Supply; C: Any Time Supply

Ref. Location	Rudra nagar Bazar	Rudra nagar Bazar	Rudra nagar Bazar	Rudra nagar Bazar	Rudra nagar Bazar	Rudra nagar Bazar
Name of Consumer	Bhuban Ch. Maity	Mahadev Maity	Nibedar Bera	Sasankya Sekhar Panda	Bala Lal Giri	Dibash Ch Bera
Address	Rudra nagar Chowringhee	Rudra nagar Chowringhee	Rudra nagar Chowringhee	Rudra nagar Chowringhee	Rudra nagar Chowringhee	Rudra nagar Chowringhee
Source of Supply	W.B .S.E.B. (1X25 kVA Tr)	W.B .S.E.B. (1X25 kVA Tr)	W.B .S.E.B. (1X25 kVA Tr)	W.B. .S.E.B. (1X25 kVA Tr)	W.B .S.E.B. (1X25 kVA Tr)	W.B .S.E.B. (1X25 kVA Tr)
Connected Load	3T+2B	1T+2B	5B	3T+5B	4T+4B	5T+7B
Light	-	-	-	2F	2F	3F
Fan	-	-	-	-	-	-
Pumps	-	-	-	-	-	1
TV	-	-	-	-	-	-
Others	2X5A Plug	2X5A	2X5A	3X5A	3X5A	4X5A
Total Load in kW	0.51	0.41	0.58	0.99	.98	1.53
Demand Load in kW	0.23	0.17	0.27	0.47	0.47	0.72
Willingness for Power A: Very Willing B: Somewhat Undecided C: Unwilling	A	A	A	A	A	A
Preferred Supply Time A: 24 Hour Supply B: Variable Time Supply C: Fixed Time Supply (When)	A	A	A	A	A	A

Table 7. System Study for Modernization of Distributed Systems at Sagar Islands –Load Demand Survey for domestic consumers [13]

Features of Systems Study as per Table 6 are as below:

Type of the Load: Domestic; Reference Location: Rudranagar Chowringhee

Source of Supply: (1X25kVA Tr) by West Bengal State Electricity Board (WBSEB)

Parameters Considered: Willingness for Power

A: Very Willing; B: Somewhat Undecided; C: Unwilling

Preferred Supply Time

A: 24 Hour Supply; B: Variable; Time Supply; C: Fixed Time Supply (When)

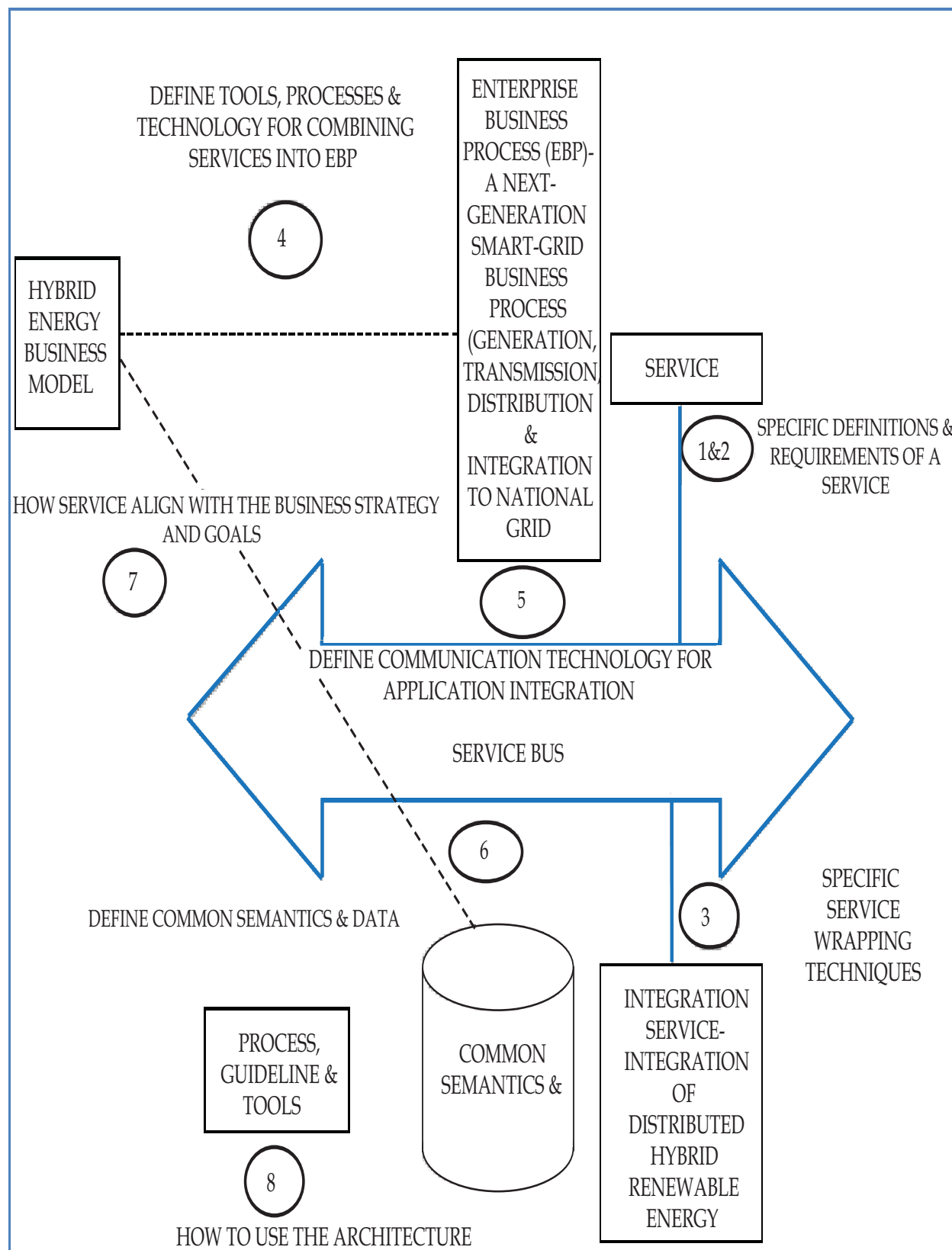

Source: Adopted from *Applied SOA: Service-Oriented Architecture and Design Strategies* by Michael Rosen, Boris Lublinsky, Kevin T. Smith, Marc J Balcer

Fig. 9. A Next-Generation Smart-Grid Perspective of SOA[7], [10]

Fig. 9 depicts a Next-Generation-Smart-Grid perspective of SOA and the numbered circles in this figure correspond to the numbered list as: (1) A definition of services, the granularity, and types of services; (2) How services are constructed and used; (3) How existing packaged and legacy systems are integrated into the service environment; (4) How services are combined into processes; (5) How services communicate at a technical level (i.e., how they connect to each other and pass information); (6) How services interoperate at a semantic level (i.e., how they share common meanings for that information); (7) How services align with the business strategy and goals; (8) How to use the architecture.

6. Acknowledgment

Our sincere thanks to the National Renewable Energy Laboratory (NREL) for incorporating NASA Surface Meteorology and Solar Energy Data. Also our sincere thanks to West Bengal Renewable Development Agency (WBREDA) for their cooperation with useful resources during research.

7. References

- [1] The Power to Reduce CO₂ Emissions: The Full Portfolio. EPRI, Palo Alto, CA: 2008.
- [2] EPRI "Turning on Energy Efficiency," *The EPRI Journal*, EPRI, Palo Alto, CA: Summer 2006.
- [3] U.S. Energy Information Administration. "Annual Energy Outlook 2008". Reference Case electricity forecast for Residential, Commercial, and Industrial Sectors.
- [4] Website: <http://www.bee-india.nic.in-Addressing Energy Security and Climate Change>.
- [5] Intergovernmental Panel on Climate Change (IPCC), 2007: Climate Change 2007.
- [6] Website: help.sap.com/saphelp_apo
- [7] Aurobi Das, V. Balakrishnan, A Next Generation Smart-Energy Technology, Proceedings of the 2nd International Conference on Computer Sciences and Convergence Information Technology (ICCIT 09), ACM International Conference Proceeding Series; Vol. 403
- [8] Aurobi Das, V. Balakrishnan, Analysis of Critical Problems In ERP Implementation to Enhance Service Oriented Architecture (SOA) for Energy & Utilities-A Case Study, Proceedings of the Enterprise Information Systems International Conference on Research and Practical Issues of EIS (CONFENIS 2009) at Gyor, Hungary.
- [9] Aurobi Das, V. Balakrishnan, Analysis of Critical Problems In ERP Implementation to Enhance Service Oriented Architecture (SOA) for Energy & Utilities-A Case Study; SEFBIS Journal No. 3. (2009): Professional Journal of the Scientific and Educational Forum on Business Information Systems; Editor: SEFBIS (GIKOF) Community of the John von Neumann Computer Society (NJSZT), ISSN 1788-2265
- [10] Aurobi Das, V. Balakrishnan, A Next Generation Smart-Energy Technology, International Journal on Research and Innovation: Advances in Information Sciences and Service Sciences(AISS), Vol 2, June 2010
- [11] Aurobi Das, V. Balakrishnan, Energy Service Companies (ESCOs) to Optimize Power in Peak Demand Period in Hybrid Energy System- An Impact on Climate Change, Proceedings of the 2nd IEEE Green Technology Conference, 2010 at Dallas, Texas
- [12] Enterprise SOA Development Handbook, Enterprise Services Enhancement Guide
- [13] West Bengal Renewable Development Agency (www.wbreda.org) & West Bengal State Electricity Distribution Company Limited (www.wbsedcl.in)

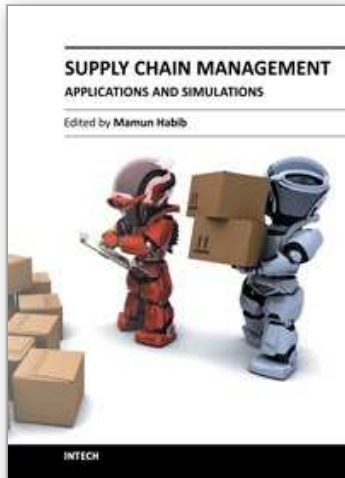

Supply Chain Management - Applications and Simulations

Edited by Prof. Dr. Md. Mamun Habib

ISBN 978-953-307-250-0

Hard cover, 252 pages

Publisher InTech

Published online 12, September, 2011

Published in print edition September, 2011

Supply Chain Management (SCM) has been widely researched in numerous application domains during the last decade. Despite the popularity of SCM research and applications, considerable confusion remains as to its meaning. There are several attempts made by researchers and practitioners to appropriately define SCM. Amidst fierce competition in all industries, SCM has gradually been embraced as a proven managerial approach to achieving sustainable profits and growth. This book "Supply Chain Management - Applications and Simulations" is comprised of twelve chapters and has been divided into four sections. Section I contains the introductory chapter that represents theory and evolution of Supply Chain Management. This chapter highlights chronological prospective of SCM in terms of time frame in different areas of manufacturing and service industries. Section II comprised five chapters those are related to strategic and tactical issues in SCM. Section III encompasses four chapters that are relevant to project and technology issues in Supply Chain. Section IV consists of two chapters which are pertinent to risk managements in supply chain.

How to reference

In order to correctly reference this scholarly work, feel free to copy and paste the following:

Aurobi Das and V. Balakrishnan (2011). Power Optimization of Energy Service Companies (ESCOs) in Peak Demand Period Based on Supply Chain Network, Supply Chain Management - Applications and Simulations, Prof. Dr. Md. Mamun Habib (Ed.), ISBN: 978-953-307-250-0, InTech, Available from:
<http://www.intechopen.com/books/supply-chain-management-applications-and-simulations/power-optimization-of-energy-service-companies-escos-in-peak-demand-period-based-on-supply-chain-net>

INTECH
open science | open minds

InTech Europe

University Campus STeP Ri
Slavka Krautzeka 83/A
51000 Rijeka, Croatia
Phone: +385 (51) 770 447
Fax: +385 (51) 686 166
www.intechopen.com

InTech China

Unit 405, Office Block, Hotel Equatorial Shanghai
No.65, Yan An Road (West), Shanghai, 200040, China
中国上海市延安西路65号上海国际贵都大饭店办公楼405单元
Phone: +86-21-62489820
Fax: +86-21-62489821

© 2011 The Author(s). Licensee IntechOpen. This chapter is distributed under the terms of the [Creative Commons Attribution-NonCommercial-ShareAlike-3.0 License](#), which permits use, distribution and reproduction for non-commercial purposes, provided the original is properly cited and derivative works building on this content are distributed under the same license.

IntechOpen

IntechOpen