

# We are IntechOpen, the world's leading publisher of Open Access books Built by scientists, for scientists

4,800

Open access books available

122,000

International authors and editors

135M

Downloads

Our authors are among the

154

Countries delivered to

TOP 1%

most cited scientists

12.2%

Contributors from top 500 universities



WEB OF SCIENCE™

Selection of our books indexed in the Book Citation Index  
in Web of Science™ Core Collection (BKCI)

Interested in publishing with us?  
Contact [book.department@intechopen.com](mailto:book.department@intechopen.com)

Numbers displayed above are based on latest data collected.

For more information visit [www.intechopen.com](http://www.intechopen.com)



# Synthesis and Thermoluminescent Characterization of Ceramics Materials

Teodoro Rivera

*Instituto Politécnico Nacional/CICATA-Legaria  
México*

## 1. Introduction

The development of novel materials represents a new and fast evolving application of research in physics and medicine. Processing synthesis is critical because it generally controls the final properties of the materials, ceramic forming techniques are generally based on powder processing with powder synthesis, forming and sintering. Moreover, ceramic processing has also to consider other techniques of synthesis and crystal growth, thin films and bulk desirable microstructures and nanostructures architectures. Luminescent of micro and nanostructured ceramics change their luminescent properties, and other topics as well as, temperature sintering process, luminescent properties by diminishing the crystallites size particles. This is closely related to the confinement effects in nano-scale materials. Among the various nano-materials, phosphor powders are attracting considerable attention because of their novel optical properties, which affect emission lifetime, luminescent efficiency. A great variety of different routes for the solution-based preparation of ceramics have been reported in the literature, using a wide range of precursor chemicals (inorganic and metal-organic), media (aqueous or non-aqueous) and methods as chemical precipitation, leading to powder products with a wide range of structure uniform powders. It has been shown that the sol-gel derived ceramics are former in particle size, narrower in particle size distribution, higher in sinterability, and more homogeneous in composition than many of those prepared via other processing routes, then sol-gel method was used to obtain ceramics powder. Precipitation method was the second method used to obtain micro and nanostructured ceramics. When a new luminescent material is proposed as candidate to functional applications, generally, various morphological, structural and functional characteristics is required i.e. crystalline structure, particle sizes, shape geometry, etc. Crystallization treatment is the first routine processes, after this process to perform a sintering processing is necessary in order to stabilize the trap structure. Annealing temperature and time are used to produce the lowest intrinsic background and to obtain the highest efficiency. One field of activities in the field of functional ceramics in luminescence is oriented towards the development of advanced materials and processes for thermoluminescence and functional applications, principally based on radiation physics detection. In this sense, different preparation methods and properties of several TL materials have been studied so far and it was found that metal oxides doped with proper activators constitute a class of promising TL phosphors. In this chapter author try to describes the details of the physics and try to show to different radiation field applications of the ceramics. The TL dosimetry (TLD) technique

offers the advantage of being able to place the dosimeters in outdoor stations for solar radiation monitoring, without requiring any additional special monitoring or logistical considerations, ceramics as well as, undoped and RE doped  $ZrO_2$  and aluminium oxide are suggested by us as a suitable TLD material to accomplish this task.

## 2. Synthesis and processing of materials and ceramics

Ceramic luminescent is a material that emits light after absorbing external energy (e.g. ultraviolet radiation, X-rays, gamma rays). This kind of material has been widely applied in the fields of illumination, display, X-ray detectors, etc. However, with the development of sciences and technology, lots of the conventional phosphors have been unable to meet the requirements of current luminescent applications. In recent years, researchers have focused their work on the improvement of the luminescence property of traditional phosphors and preparation of new luminescent material. In this sense, different preparation methods and properties of several TL materials have been studied so far and it was found that metal oxides doped with proper activators constitute a class of promising TL phosphors.

### 2.1 Microstructured materials

Traditionally,  $CaSO_4:Dy$  thermoluminescent materials are used extensively for the radiation dosimetry purpose due to low cost, high sensitivity, and very high storage stability in ambient climatic conditions (Azorín, 1990). However, the integrated processes of sintering and microstructure development in a crystalline compound are so complex that even after 50 years of research. Over this time, research on luminescence micro and nanocrystalline materials has been greatly accelerated by the advances in the ability to manipulate structures at molecular or atomic level (Rivera et al., 2010a; Salah et al., 2006a). Most of the studies have been directed towards the synthesis, characterization, and application of these systems as structural and optical or electronic materials (Salah et al., 2006b). Many ceramic compounds are most easily prepared in a powder form. Powders-based processing allow the fabrication of ceramics at temperatures that are hundreds of Celsius degrees lower than are possible by the melt processes often used for metals and polymers. Powder processing also results in ceramic components with microstructures that are ideal for luminescent applications. Both chemical and morphological control of many advanced ceramic powders have been achieved at the commercial level, for compounds including aluminium oxide, zirconium oxide polycrystalline, silica, and barium titanate. Research in ceramics processing is extremely diverse, and encompasses all activities which contribute to the science and technology of fabricating ceramic materials in a useful form. Ceramics manufacturing has historically been based primarily on powder processes. The basic fabrication steps in producing such a ceramic component consist of powder synthesis, powder forming, and sintering. An important role of basic research is to address the chemical and physical phenomena involved in each of these steps. A largely qualitative understanding of sintering and microstructure development has evolved over recent years, leading to successful control of the sintered microstructure of many structural and functional ceramics, i.e. translucent alumina, toughened zirconia.

### 2.2 Nanostructured materials

The integration of powders of controlled size and shape with handling procedures based on principles of colloid and interfacial science has permitted the development of new powder

processing paradigms. For example, the improvement in mechanical properties of structural ceramics has been enabled by better powders and more thoughtful processing to avoid the deleterious effects of aggregates. Powders with particle sizes on the nanometer scale have the potential for further decreasing firing temperatures, and thereby developing new applications. The development of new tools suitable for nanoscale particles such as computational chemistry and improved understanding of colloidal behaviour at the nanoscale are required. Furthermore, there is a need to develop processing schemes that utilize more environmentally-benign aqueous systems rather than organic solvents.

### **2.3 Routes for solution-based preparation**

Various methods to synthesize ceramics materials have been reported based on traditional approaches to modify the band structure of the materials as well as the characteristics of their trapping centres. Interest in synthesizing based ceramics has increased considerably in recent years as possible technological applications triggered a wide variety of research activities on this material.

#### **2.3.1 Precipitation method**

Currently, nanotechnology and nanomaterials have attracted several researchers from different fields (Heuer & Hobbs, 1981), especially from the field of luminescence. It has been found that the physical properties of individual nanoparticles can be very different from those of their bulk counterparts. Recent studies on different luminescent nanomaterials have showed that they have a potential application in dosimetry of ionizing radiations for the measurements both of low and high doses using the thermoluminescence (TL) technique, where the conventional microcrystalline phosphors saturate (Kumar et al., 1994; Rivera et al., 2007b). For high doses, the saturation occurs due to the ionized zones overlapping each other in some micromaterial. The TL results of the reported nanomaterials have revealed very imperative characteristics such as high sensitivity and saturation at very high doses. Among the preparation methods of luminescent materials, homogeneous precipitation method not only has the advantages of simple process, convenient for doping and low production cost, but also can prepare uniform and small sized particles, because the precipitants are formed slowly and homogeneously throughout the solution during the precipitation process.

#### **2.3.2 Sol-gel method**

The interest in sol-gel synthesis of luminescent materials arises from the relatively low cost of the method; as well as the approach that allows the chemical content and concentration ratio of the elements of the sol-gel derived powders to be tailored, with ready fabrication into different solutions. More specifically, the sol, i.e., the dispersion of colloidal particles of diameter 1 to 100 nm in a liquid (Rivera et al., 2007c), is able to penetrate through the interacting channels of mesoporous matrices, enabling to fabricate a luminescent xerogel located on the surface porous powders of several  $\mu\text{m}$  in grain size (Brinker & Scherer, 1990). The idea behind the chemical synthesis of micromaterial is to transform molecular precursors into materials under retention of the structural units, which are inherent to the precursor molecule and also forms and integral part of the solid-state structure. Although, the concept of synthesizing materials from molecule has long been shifted to the synthesis of new materials with novel compositions (Brinker & Scherer, 1989). Among the commonly used precursors to oxides such as halides, nitrates, acetates, carboxylates, alkyls, alcoxides,

etc., metal alkoxides  $[M(OR)_n]$  are specially attractive due to the pre-existent metal-oxygen bonds. The sol-gel process based on the hydrolytic decomposition of metal alkoxides has been successfully used for the synthesis of a large number of monometal oxides phases ( $Al_2O_3$ ,  $TiO_2$ ,  $ZrO_2$ , etc.). However, metal alkoxides  $[M(OR)_n]$  are preferred precursors to oxides because of their pronounced tendency to associate by forming  $M(OR)_n-M'$  type bridges. When carefully hydrolyzed, metal alkoxide derivatives produce molecular entities containing oxo-and/or hydroxo-bridges, they can associate themselves via hydrolysis and cross-condensation reactions to form macromolecular networks. In recent decades, zirconia dioxide ( $ZrO_2$ ) has attracted great interest due to its extensive practical applications as a structural ceramic (Rivera et al., 2007d).

## 2.4 Ceramic polycrystalline powder

For luminescent materials, this is crucial since the light emission is usually due to crystalline structure or doping ions like rare-earth or transition metals ions. Quenching concentrations are usually found higher for sol-gel-derived materials because of better dispersion of doping ions and thus higher average distance between emitting centres. Several authors have also developed heterometallic precursors associating different elements through chemical bonding and thus providing the highest homogeneity.

### 2.4.1 Metal alkoxides

In particular, transition metal alkoxides are very reactive because of the presence of highly electronegative OR groups that stabilize the central atom in its highest oxidation state. This in turn makes the metal atom very susceptible to nucleophilic attack. The point where this network extends throughout the reactor is described by the percolation theory and named the gel point. The obtained wet gel can be dried in various conditions leading a xerogel with residual porosity. Further heating of the xerogel in controlled conditions allows obtaining the desired glass or ceramic. Furthermore, the temperatures required for the full densification and crystallization of the desired glass or ceramic are usually lower than the ones required by classical melting or solid-state processes (Aguilar et al., 2001; Petrik et al., 1999). This can be interesting from an economical point of view but also because in some cases, the obtained phases can differ from the one obtained by classical procedures. By this way, new phases can be obtained or high-temperature phases can be stabilized at room.

### 2.4.2 Zirconium oxides

Zirconium dioxide ( $ZrO_2$ ), which is also referred to as zirconium oxide or zirconia, is an inorganic metal oxide that is mainly used in ceramic materials. Zirconium dioxide is the most important zirconium compound which due to its properties is used in various products. In nature,  $ZrO_2$  occurs in the mineral form as baddeleyite, a modification in monoclinic crystal lattices. The sol-gel synthesis of  $ZrO_2$  powder involves hydrolysis and condensation of zirconium (IV) propoxide in ethanol solution (Rivera et al., 2007c). The hydrolysis and condensation reactions, which take place as a result of mixing two parts of alcohol solution, can be described as:



Generally,  $Zr(OPrn)$  (13.3 mmol, 6ml of 70 wt% solution) adding by drops up to 48 ml (2.667 mol) of deionized water acidified with nitric acid to pH 1 in a nitrogen atmosphere. During this step, a white suspension is formed immediately. Then, the suspension is heated for 24 h at 80°C. After this, other 100 ml of deionised water acidified to pH 1 is added to initial suspension, and it is maintained with vigorous stirring at room temperature (RT) for 72 h. The stirring is performing in order to disperse the aggregates into small particles and small aggregates. After this, a-Zr:H powders of different sizes is obtained and then dried at 120°C for 20 h. Finally, powder is submitted thermally at a temperature of 1100 °C for 5 h.

### 2.4.3 Aluminium oxide

Alumina is the most cost effective and widely used material in the family of engineering ceramics. The raw materials from which this high performance technical grade ceramic is made are readily available and reasonably priced, resulting in good value for the cost in fabricated alumina shapes. Aluminium oxide, commonly referred to as alumina, possesses strong ionic interatomic bonding giving rise to its desirable material characteristics (Salah et al., 2011; Sallé et al., 2003). Alpha phase alumina is the strongest and stiffest of the oxide ceramics (Gitzen, 1998). This is the phase of particular interest for luminescent applications. Ceramic oxide of aluminium oxide powder has been obtained using solvent evaporation method (Rivera et al., 1999). The solution is heated at 250°C for half an hour, then evaporation 700°C for half an hour. In order to stabilize the traps, powder obtained is then submitted to thermal treatments of two hours at the following sintering temperature: 500, 700 and 900°C.

### 2.4.4 Zirconium oxide-aluminium oxide

The uniform dispersion of zirconia particles in the alumina matrix can be controlled by homogeneous powder synthesis techniques. The  $ZrO_2-Al_2O_3$  ceramic composites display different properties depending on the precursors, chemical composition and preparation route. The  $ZrO_2-Al_2O_3$  ceramic composite has been observed that the structure of the matrix material and the zirconia particles dispersed in the alumina matrix are so important in order to produce optimally tough transformation-toughened composite materials that increase the mechanical and thermal properties of the composite (Li et al., 1995; Taavoni et al., 2009; Zhang & Glasser, 1993). Among the preparation methods of zirconium-aluminium luminescent materials, sol-gel method has been the most appropriate synthesizing method. Homogeneous mixtures of pseudoboehmite with average formula  $Al_4O_3(OH)_6$  obtained from U.G. Process (Zarate et al., 2005) and t- $ZrO_2(Y_2O_3)$  were prepared by a mechanochemical treatment employing  $HNO_3$  as a peptising agent. The U.G. process is related with the alkaline desulphatation of  $Al_2(SO_4)_3$  using an ammonia solution (Rivera et al., 2010b). Suspensions of precursory powders were prepared with pseudoboehmite seeded during mechanochemical treatment with 2.5 mass% a- $Al_2O_3$  of 0.20  $\mu m$  (Taimicron, TM10) and tetragonal zirconia powders (TOSOH, TZ-3YS) with average particle size of 0.26  $\mu m$  were added in adequate proportions for each composition (100, 90, 70, 50, 30, 15 and 0 mass % of  $ZrO_2$ ). The suspensions were stirred and spray dried using a YAMATO Mini-spray dryer ADL31. The precursory powders were submitted at 1200°C.

### 2.4.5 Hafnium oxides

The hafnium oxide ( $HfO_2$ ) is a material with a wide range of possible technological applications because of its chemical and physics properties as high melting point, high

chemical stability, and hardness near to diamond in its tetragonal phase. The large energy gap and low phonon frequencies of the  $\text{HfO}_2$  makes it appropriate as host matrix for being doped with rare earth activators. Hafnium oxide ( $\text{HfO}_2$ ) films have been deposited by a variety of techniques; these include atomic layer epitaxy, chemical vapour deposition, and electron beam evaporation. Ultrasonic spray pyrolysis represents an alternative processing method that has been employed for deposition of wide variety of films and coatings and several type of powders production. The  $\text{HfO}_2$  films were grown using the ultrasonic spray pyrolysis technique (Guzman et al., 2010). The precursor solution is atomized and goes away to corning glass substrate heating on a tin bath by dry air flow. The starting reagents to  $\text{HfO}_2$  films deposition was  $\text{HfCl}_4$  in deionised water as solvent; the initial solution was prepared to a 0.05 M. Deposition temperatures ( $T_s$ ) were in the range from 300°C to 600°C. Filter air as carrier gas was used at flow rate of 10 l/min. The deposition time was 10 minutes for all the samples in order to reach almost same films thickness. The films show a deposition of about 2  $\mu\text{m}$  per minute.

### 2.5 Ceramic thin film

Ceramic thin films are presently used in, and will continue to be developed for, a multitude of devices critical to luminescence and optoelectronics technology. The processing of thin-film ceramics differs from that of many other materials due to the complex microstructures and defect structures that can arise in complex ionic and covalent compounds. The fundamental knowledge base necessary for understanding and predicting the orientation and microstructure of ceramic thin films does not now exist (Agarwal et al., 1997; Asiltürk et al., 2011; Rivera et al., 2005a). The nucleation and growth mechanism of ceramic compounds in thin film form is also poorly understood, as are the mechanical strains that accompany film formation, and the surface morphologies of ceramic thin films. Furthermore, many applications of thin film ceramics require deposition at very low temperatures. The role of nonthermal sources of energy in determining ceramic film microstructure is emerging as a fascinating area for future research, as is the processing of low density (microporous) ceramic films for their ultraviolet dosimetry properties (Deis & Phule, 1992). Bulk processing remains important, while many of the new device applications requires processing in thin film form. Thin film techniques via Spray pyrolysis deposition and sol-gel need to be developed for doped (e.g., with rare earth elements) materials for integrated photonic applications. As the deposition technique, spray pyrolysis is a simple technique that allows obtaining good quality films over extended areas at low cost (Chacon et al., 2008; Guzman et al., 2010). The ceramic thin films generally grow with a crystalline microstructure (Azorín et al., 1998).

### 2.6 Development of advanced ceramics

The science and engineering of ceramic is rich with fundamental questions related to the synthesis, fabrication, and characterization of physical and luminescent properties. The synthesis approaches and the luminescent materials produced can perhaps be conceptually separated according to the size scale of the microstructure produced (Langlet & Joubert, 1993). Nanostructure processing offers new capabilities for manipulating materials microstructural and compositional variation on the nanometric scale (Rivera et al., 2007c; Shang et al., 2009). Due to their fine grain sizes, ultra high surface-to-volume ratio can be achieved in nanocrystalline materials. Therefore, the large number of atoms located at the edges and on the surfaces of nanocrystallites provides active sites for luminescent surface.

Furthermore, nanocrystallites have unique hybrid properties characteristic of neither the molecular nor the bulk solid state limits (Taavoni et al., 2009). Nanocrystalline processing offers a practical way for retaining the results for appropriate manipulation on the atomic or molecular level, producing novel materials with unique size-dependent behaviour, including quantum confinement effects, greater microstructural uniformity for better optical reliability, and high ductility and super plasticity for advanced ceramics (Nalwa, 2000; Sasikumar & Vijayaraghavan, 2010; Somiya et al., 1988). The ability for producing luminescent materials with the desired microstructure and active component dispersion can bring significant advances in the field of luminescence. This can be accomplished through nanostructural processing of materials (Rivera et al., 2006). Besides their composition, luminescent materials are also characterized by their microstructure: grain size, surface state or interface with their host media and packing of the particles within the material. The optimization of the luminescent properties of phosphors, varying their nanostructure, is a subject which has certainly not been fully investigated up to now. It is nevertheless clear that the excitation energy, the surface defects, the efficiency of light extraction and the interface between the phosphor grains and their environment are parameters which are affected by the nanostructure of the material (Azik et al., 2008; Zhang et al., 2005; Wang et al., 2005). This influence is enhanced for small grain sizes, giving a real motivation for the synthesizing phosphors with dimensions of their microstructure closer to the nanometer size range.

Thermoluminescent nanoparticles with dimensions smaller than or in the order of the size of the bulk exciton show unique optical properties, which depend strongly on the size. These properties have stimulated great interest in luminescent (thermoluminescent) nanoparticles both from a fundamental and from an applied point of view. One of the main problems in understanding variations in the quantum efficiency of nanoparticle luminescence is the large surface area and the role of (surface) defects in the luminescence process. As a result, the luminescence quantum efficiency is extremely importance to the synthesis conditions. Luminescent semiconductors form an important class of phosphors with applications in the thermoluminescent (TL) phenomenon studies (Lochab et al., 2007; Azorín et al., 2007).

### 3. Temperature effect on ceramic processing

Before using a thermoluminescent (TL) ceramic material for dosimetric proposes, it has to be prepared. To prepare a TL material means to synthesize, crystallizes and perform to luminescent application. In order to prepare a new thermoluminescent material for use, it is needed to perform a thermal treatment process, this thermal treatment consist in four steps, i.e. crystallization treatment, initialization treatment, annealing treatment and post-irradiation treatment (Furetta & Weng 1998).

#### 3.1 Crystallization treatment

Poorly crystallized or truly amorphous material commonly comprises from 10 to 50 volume percent of typical amorphous material. The available phase quantification methods treat this significant fraction of the coating differently (Diaz et al., 1991; Yoshimura et al., 1999).

Rivera et al. (Rivera et al., 2005b) studied crystallization treatment process on hydrogenated amorphous zirconia (a-Zr:H) powder. The first stage of the procedure involves heating materials inside a furnace using different crystallization parameters (temperature and time)



indicated for the luminescent material under test. The ceramic powders are placed in lidded crucible which is placed in the furnace and submitted at different thermal treatment. After each thermal treatment, the powders are cooled in their containers in a reproducible manner. Alternatively, the crucible may be removed from the furnace immediately after the thermal treatment in order to allow the powders to be cooled much faster to room temperature. It is imperative to use always the same cooling procedure and that this is reproducible because the luminescent properties of the material are strongly affected by the cooling. In some case the crystallization thermal treatment procedure consists of two or more subsequent steps. An example is given by zirconium oxide powder form, which needs a first thermal treatment at 600°C during 1 h. After this thermal treatment, ceramic powders are submitted at 800°C during 1 h. Finally, a third thermal treatment is applied, this thermal process consist in a thermal treatment at 1100°C during 5 h. At the end of the thermal procedure the powders are read to check the background signal (see fig. 1). In case thermal treatment is applied at different temperatures, this is finished when the background is very low and constant for the whole powder.

Crystallization thermal treatment temperature affects significantly both the glow curve shape and the TL intensity of ceramics (e.g.  $ZrO_2$ ,  $TiO_2$ ,  $Al_2O_3$ ). Rivera et al. (Rivera 2009, Aguilar 2001) analyze crystallization thermal effect on the  $ZrO_2$  ceramics after thermally stimulation process. They observed, crystalline structure is changing when ceramics are submitted under crystallization temperature. These changes of the glow curve with the crystallization temperature may be correlated with a possible increasing of the oxygen vacancies concentration in the forbidden gap of the material (Hassan et al., 2009).

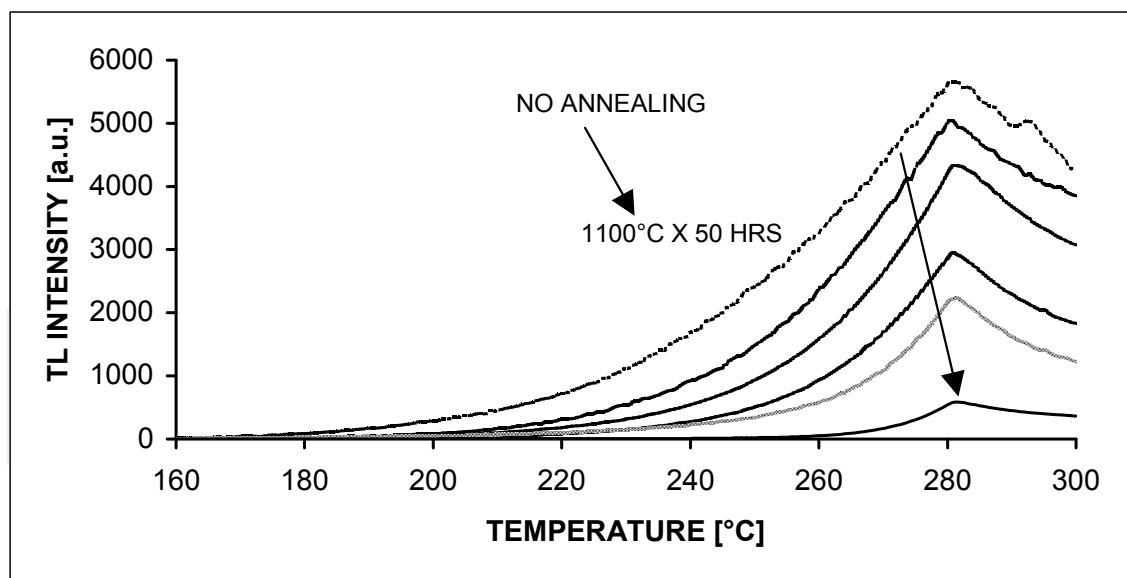

Fig. 1. Background signal of ceramics after crystallization treatment

This correlation indicates that even the powder crystallinity improves, as indicate by X-ray diffraction measurements, the presence of oxygen vacancies is very important for producing the light emission. This emission is probable due to the oxygen vacancies acting as electron trap centres. The shape of the glow curve is finally well defined for 5 hours at 1100°C (see fig. 2). The peak is well defined and centred at around of 190°C.

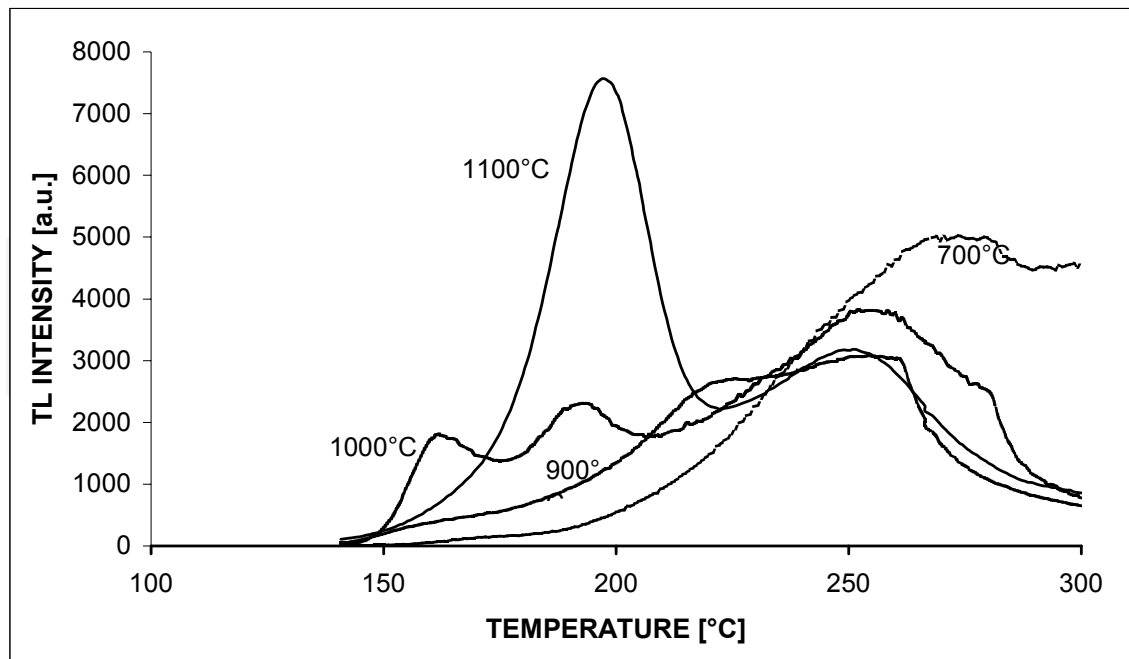

Fig. 2. TL glow curves of  $ZrO_2$  after crystallization treatment process.

### 3.2 Temperature sintering process

In some cases, although, sintering is an essential process in the manufacture of ceramics, as well as several other functional applications, until now, no single book has treated both the background theory and the practical application of this complex and often delicate procedure. Sintering process is the end of the thermal process of crystallization ceramics (Ferey et al., 2001; Suk, 2005). The sintering process provides the energy to encourage the individual powder particles to bond or "sinter" together to remove the porosity present from the compaction stages. During the sintering process the "green compact" shrinks by around 40 vol % (German, 1996). Sintering process of ceramic materials is the method involving consolidation of ceramic powder particles by heating the green compact part to a high temperature below the melting point, when the material of the separate particles diffuse to the neighbouring powder particles (Chang & Su, 1993). The process of sintering (solid state) can be divided in three stages that phenomenologically appear and can be identified (see fig. 3). These stages differ from the form and transport mechanisms begin to dominate as it evolves during the sintering. There is an initial phase where they join the powders without contraction. In this phase, the surface transport mechanisms are of vital importance. At this stage, the sintering process starts with an aggregation of particles and the disappearance of the border began to produce a neck in the points of contact between the particles. Grain boundaries are formed between two adjacent particles in the contact plane. The centres of the particles are only slightly closer, which means very low shrinkage. Usually, it will reach an equilibrium value in the grain size due to surface tension called intermediate stage. In the intermediate stage the pores have been reduced due to the growth of the neck of the initial stage (Nasar et al., 2004). There is a large contraction in comparison with the other stages; the pores are reorganized in order to leave maximized the contact area of a particle with other particles obtaining a porous structure.

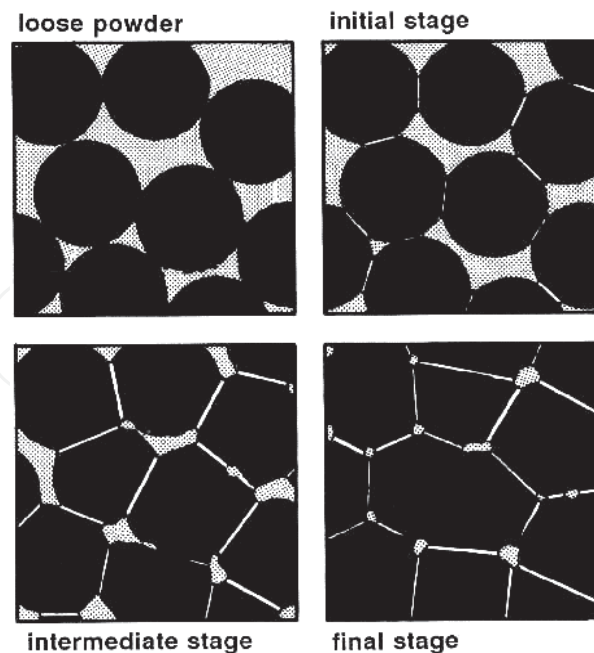

Fig. 3. Sintering process in ceramic powder

Later, when activated further filling processes or mass transport, is beginning to see a larger contraction. Cylindrical forms pores taken to minimize and then come to a final stage where the pores are closed and dispersed. Turning to a final stage, where the pores into a state of instability, they prefer to divide and spread evenly over the material. At the end of the sintering process density of the material is reached between 90 and 95% of the theoretical calculations. The amount of closed porosity increases rapidly and solidifies into spherical isolated pores. The densification is almost zero and takes a strong grain growth

The influence of temperature on the thermoluminescent ceramic powder is very notable, characteristics of the TL glow curve of ceramics polycrystalline powder for different applications is studied. Particularly, luminescent applications polycrystalline powder ceramics is improvement as sintering process is increased.

### 3.3 Thermal luminescent process

This thermal treatment is used for new (fresh or virgin) thermoluminescent materials which have not been used. The aim of this thermal treatment is to stabilize the trap levels, so that during subsequent uses the intrinsic background and the sensitivity are both reproducible. The time and temperature of the initialization annealing are, in general, the same as those of the standard annealing. Standard annealing process is used to erase any previous residual irradiation effect which is supposed to remain stored in the crystal after the readout. It is carried out before using the TLDs in new measurements. The aim of this thermal treatment is to bring back the traps-recombination centres structure to the former one obtained after the initialization procedure.

#### 3.3.1 Initialization treatment

The first stage of the procedure involves heating dosimeters inside a furnace using the optimum annealing parameters (temperature and time) indicated for the TL material under test. The actual duration of annealing will be longer than the required annealing time in

order to attain thermal equilibrium at the required temperature (Furetta & Weng, 1998). Alternatively, the crucible may be removed from the furnace immediately after the thermal treatment in order to allow the dosimeters to be cooled much faster to room temperature. At the end of the annealing procedure the dosimeters are read to check the background signal. The background depends on the high voltage, applied to the photomultiplier tube, on this age and on the room temperature stability of the TL reader must be checked before and after annealing reading session. The background values determined for each dosimeter have to be collected, which is memorized in a file, so that they can be used for the successive tests. In many cases an average background value is considered for the whole batch and then subtracted from each individual reading of the irradiated TLDs. This procedure is valid when the background is very low and constant for the whole batch.

### 3.3.2 Annealing treatment

In order to prepare a thermoluminescent material to be used for dosimetric applications, it is necessary to perform a thermal treatment process, usually called annealing. This process is carried out in oven, heating the TL samples up to a given temperature, keeping them at this temperature for a given period of time and then cooling down the samples to room temperature (Y. Zhang, et al., 2002). Thermal treatments used in this study can be classified into two main different types: (a) Initialization treatment, which was used on virgin  $ZrO_2$  samples. The aim of this thermal treatment is to stabilize the trap levels, so that during subsequent uses both the intrinsic background and the sensitivity should be reproducible. (b) The second class of the thermal treatment corresponds to the pre-irradiation annealing, also called: standard annealing. This treatment is used to erase any previous residual irradiation effect which is supposed to remain stored in the crystal after the readout. The general aim of this thermal treatment is to bring back the trap-recombination center structure to the original one as obtained after the initialization procedure.

When a new TL material is going to be used for the first time, it is necessary to perform at first an annealing study which has two main goals. (i) To find a good combination of annealing temperature and time to stabilize the trap structure; (ii) to produce the lowest intrinsic background and to obtain the highest reproducibility of TL response.

### 3.3.3 Post-irradiation treatment

This kind of the thermal treatment is used to erase the low temperature peaks, if they are found in the glow curve structure. Such low temperature peaks are normally subjected to a quick thermal fading and many times this value is not been included in the readout to avoid any errors in the dose determination. In all cases, value and reproducibility of the cooling rate after the annealing process are of great importance for the performance of a TLD system. In general, the TL sensitivity is increased using a rapid cool down. It seems that the sensitivity reaches the maximum value when a cooling rate of 50-100°C/s is used. It must be noted the thermal procedures listed above can be carried out in the reader itself. But in many times when TLDs are many, TL reader is not enough for each TL materials to avoid spent a lot time an oven is used. Temperature annealing is monitored in step by step in order to care any variation time not listed. This is important for TL materials embedded in plastic cards (personnel dosimetry) or TL materials embedded in plastic medium as agglutinate material (Teflon) as material support for TL chips performing. In fact, the plastic material is not to able to tolerate high temperatures and the in-reader annealing is shortened to a few seconds.

## 4. Structural and morphological characterization

The requirements for high-quality special ceramics with certain physical and mechanical properties call for a functional characterization of the raw materials after various processing steps. Several methods have been described for determining the phase composition and the amorphous of ceramics (Rivera et al., 2007d). Extremely interesting is the characterization of these ceramic materials from the structural by means of X-ray diffraction and morphological by means of scanning electron microscopy methods, with the aim of fully understanding the reasons for their macroscopic properties, and of being able to examine the possibility of modifying and improving them.

### 4.1 X-Ray Diffraction method (XRD)

X-ray diffraction (XRD) is an important tool in luminescence for identifying, quantifying and characterizing optical materials in ceramic materials. Its application to photonic ceramics and its transformation products yields information on the ceramic composition of the compounds. Details of synthesizing processes, like firing temperatures and crystallization process as well as applications of ceramics may thus become optimums. X-ray diffraction process its application in luminescent ceramics is relevant. While it is relatively easy to determine which ceramics impurities contains from the positions and rough intensities of the diffraction peaks, which attributed luminescence performance. The identification of crystalline zirconium oxide in ceramics powder by XRD is a fine example where not only the presence of peaks has to be considered, but also their relative intensities need to be taken into account quantitatively, not only if one wishes to determine the zirconium oxide concentration quantitatively, but even to be able to identify zirconium in the ceramic material at all (Hideo et al., 2006). The major problem with zirconium oxide in ceramics is that its best diagnostic peak, the 002 reflection, coincides with the most intense peak 101 of the omnipresent baddeleyite. Determination of structural properties such as crystallite size and lattice distortions leads to a considerably improved characterization of ceramic powders and compacts during processing (Yoshimura et al., 1999). The application of this method to powder metallurgy problems is shown by the example of aluminium oxide or zirconium oxide after different thermal processing steps: quality control of the powders, structural changes, luminescence changes, etc. Complementary morphological investigations may broaden the understanding of the spatial arrangement of the particles in densified ceramic materials. Compacted but still porous  $\text{Al}_2\text{O}_3$  is used to show the significance of morphological studies of the fracture surface and also studies on structural defects (Thompson et al., 1987).

Keller (Keller, 1995) has been described a parallel beam XRD method developed for determining the percent crystallinity of fully crystalline and "fully amorphous" powders. Rivera et al (Rivera et al., 2007d) reported of analyzing on structural characterization of  $\text{ZrO}_2$  powders, using a Siemens D5000 diffractometer employing nickel-filtered  $\text{Cu K}\alpha$  radiation ( $\lambda = 1.5406 \text{ \AA}$ , 40 kV, 30 mA) at  $0.020^\circ$  intervals in the range  $20^\circ \leq 2\theta \leq 75^\circ$  with 1s count accumulation per step directly from the catalyst foils. Their contribution on structural and morphological on X-ray diffraction patterns of  $\text{ZrO}_2$  powder obtained by the sol-gel method and submitted to thermal treatment at  $700^\circ\text{C}$  for 10 h in air were relevant. The paper shows the diffraction patterns suggested a monoclinic phase of Zirconia. A monoclinic zirconia structure is observed to be predominant when the material is annealed at  $1100^\circ\text{C}$ . The strongest peak appeared always at around  $2\theta = 28.17^\circ$  corresponding to the (-111)

monoclinic reflection. This spectrum is in excellent agreement with the reference spectrum (Powder Diffraction File # 37-1484) of zirconia. Except for the peak at around  $2\theta = 31.5$  the other peaks with relatively weak intensities are described to the diffractions from the monoclinic structure. The line broadening of the highest peak at  $2\theta = 28.17^\circ$  was used to estimate the average grain size of the powder. Assuming the particles to be stress-free, their size was estimated using the equation of Scherrer. Powder materials with average nanopolycrystalline sizes from 8-10 nm up to about 40 nm were obtained.

For the monoclinic phase of the  $ZrO_2$  powder, the intensity is denoted by the (-111) plane; meanwhile, the other individual planes are found to be comparable to those expected for standard  $ZrO_2$  which indicates randomly oriented crystallites in the powder. As thermal annealing is increased the intensity from the (-111) plane starts becoming higher (see fig. 4). However, at  $1100^\circ\text{C}$  the ratio exceeds the standard one, showing the preferential orientation to lie along the (-111) plane. For the material annealed at  $1100^\circ\text{C}$ , other weak intensity peaks are observed at  $2\theta = 49.3^\circ$  (220),  $50.2^\circ$  (which corresponds to the (022) plane),  $24.04^\circ$  (110),  $35.3^\circ$  (002) and  $(34.2^\circ)$  (which corresponds to the (200) plane). All these planes show only one preferred orientation. The preferred orientation along (-111) plane has the lowest Gibbs free energy.

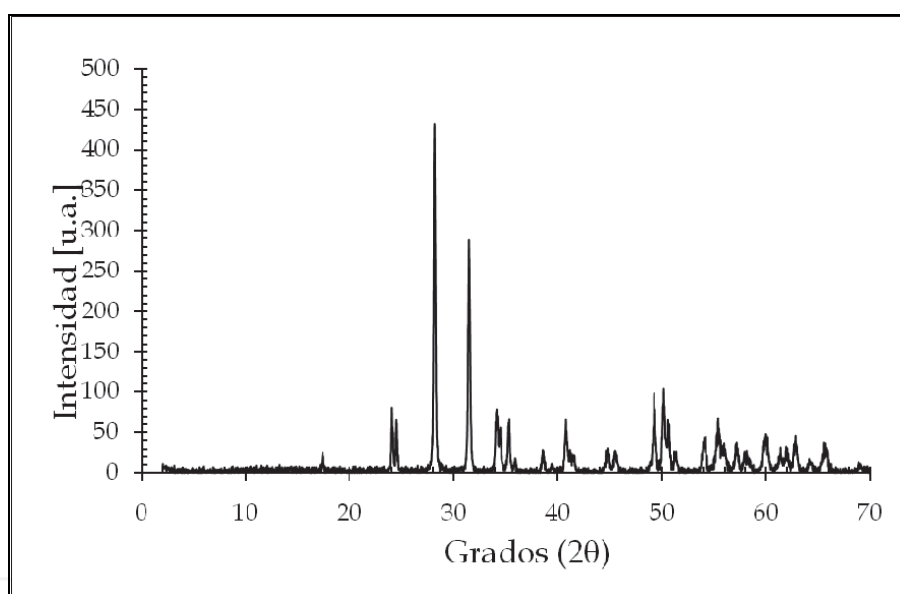

Fig. 4. X-ray diffractogram of zirconium oxide powder submitted at  $1100^\circ\text{C}$

There has been increased interest in fabricating crystalline-textured materials using the influence of an external energy source against the luminescent property of the materials. It is well known that many solid-solution systems can produce semiconducting materials with properties that are useful for electronic and optical applications. One requirement that needs to be considered when using ceramics as luminescent materials is their microstructural properties since those ceramics must be subjected to vibration and strain.

#### 4.2 Scanning electron microscope

The scanning electron microscope (SEM) has proved of great value in the examination of luminescent ceramic materials obtained for two different method preparations (precipitation and sol-gel). In a scanning electron microscope, a tiny electron beam is scanned across the

sample. Simultaneously, the generated signals are being recorded, and an image is formed pixel by pixel. Valuable information about morphology, surface topology and composition can be obtained (De Lange et al., 1995). SEM microscopes achieving resolutions below 1 nm are available now. This technique forms images with electrons instead of light allowing high magnification photographs with excellent depth of field. At 100,000X magnification a penny is roughly a mile in diameter. The EDS detector on this instrument allows identification of the elements present in ceramic matrix as impurity (Hernández et al., 2009). The scanning electron microscope (SEM) is one of the most versatile instruments available for the examination and analysis of microstructural characteristics of ceramics (Hideo et al., 2006). The primary reason for the usefulness of the SEM is the high resolution that can be obtained when bulk objects are examined. Scanning Electron Microscopy (SEM) has been for high magnification imaging and elemental analysis. For morphological ceramic characterization a Jeol JSM-6400 scanning electron microscope equipped with an energy dispersive spectrometer (EDS) has been used. According to figure 5 on micrography of  $\text{Al}_2\text{O}_3$  ceramics obtained at  $1400^\circ\text{C}$ , it can be observe a heterogeneous microstructure with regions of small grains and regions of large grains of irregular shapes and the presence of micropores intergranulares. As sintering thermal process is increase micropores intergranulares decrease in the size still the micropores are overlapping (see fig. 5). This phenomenon is observed as sintering temperature is increased to achieve uniformity in the microstructure and so compact of the powders is observed. Pores distribution and surface area of ceramics can be measured using the SEM techniques and these properties can be correlated with luminescence properties.

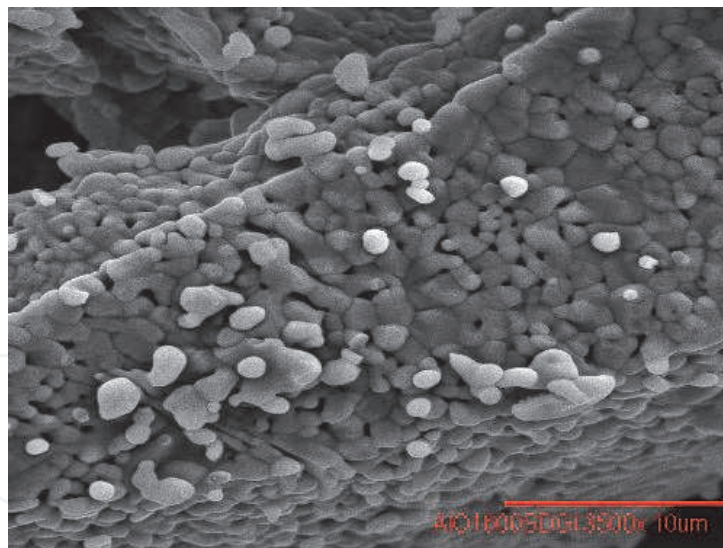

Fig. 5. Scanning electron microscopy micrographs of  $\text{Al}_2\text{O}_3$  ceramics

## 5. Luminescent characterization

Enormous progress has been made in recent years in the study of ceramic free surfaces, grain sizes, grain boundaries, and ceramic or metal interfaces. High resolution TEM, analytical electron microscopy, scanning probe microscopies, and surface and interface spectroscopies are amongst the tools which have contributed greatly to developing an atomic level understanding of such phenomena as intergranular film formation, crystalline surface

anisotropy, wetting, and heterogeneous chemical reactions. These tools and approaches should now be brought to bear on ceramic properties for luminescent applications.

### 5.1 Luminescence process

Luminescence is “cold light” from other sources of energy, which can take place at normal and lower temperatures. In luminescence, some energy source kicks an electron of an atom out of its ground state into an excited state; then the electron gives back the energy in the form of light so it can fall back to its ground state (Mishra et al., 2011). Fluorescence and phosphorescence are two special aspects of luminescence. The phenomenon is fluorescence if emission takes place by one or more spontaneous transitions. If the emission occurs with the intervention of a metastable state followed by return to the excited state due to addition of energy, then this is called phosphorescence (Furetta & Weng, 1998). There are varieties of luminescence phenomena observed in the nature or in manmade articles. The nomenclature given to these is invariably related to the exciting agent, which produces the luminescence. i.e. (i) Photoluminescence is distinguished in that the light is absorbed for a significant time, and generally produces light of a frequency that is lower than, but otherwise independent of, the frequency of the absorbed light. (ii) When excitation is done by electron beams generated at the electrical cathodes, the emission produced is called cathodoluminescence. (iii) Chemiluminescence is not a common accompaniment in chemical reactions, because the amount of energy released even in the exothermic reactions is not sufficient to cause electronic excitation, which needs a couple of eV energy. (iv) Bioluminescence is luminescence caused by chemical reactions in living things; it is a form of chemiluminescence. (v) A large number of inorganic and organic materials subjected to mechanical stress, emit light, which is called triboluminescence. (vi) Thermoluminescence is phosphorescence triggered by temperature above a certain point. In thermoluminescence, heat is not the primary source of energy, only the trigger for the release of energy that originally came from another source.

### 5.2 Photoluminescence in ceramics

Photoluminescence (PL) is generally taken to mean luminescence from any electromagnetic radiation. The principles of PL are very simple an exciting light source is focused on to the sample under observation. The energy of the light normally exceeds the band gap energy of the ceramic (Nakajima & Mori, 2006; Song et al., 2002). The light sent out by the ceramic is collected and focused onto the slit of a monochromator. In the monochromator the light is dispersed by gratings and the monochromatic light is detected by a light sensitive detector. By rotating the gratings, different wavelengths may be detected and if the signal from the detector is simultaneously recorded one will obtain a spectrum. The differences in the PL intensities observed are generally attributed to the dopants or optical defects localized into ceramics. This, characterization techniques has recently emerged as powerful tools for developing and monitoring the fabrication of high efficiency luminescent ceramics.

Optical and electronic properties of nanocrystalline materials strongly depend on their composition, structural and morphological characteristics, but also on the presence of defects. For crystallite size comparable to Bohr exciton radius of particular materials the quantum size effects become important, the band gap grows, and the optical and electronic properties of nanomaterial differ significantly from its bulk counterpart. On the other hand, presence of intrinsic defects and impurities may introduce different electronic levels within



the band-gap, which can cause the various electronic transitions mediated by these levels and variation of the optical band gap energy as well (Jacobsohn et al., 2010). The luminescence is a process of emission of optical radiation from a ceramic from causing other than heating it to incandescence.

Rivera et al. (Rivera et al., 1999) studied and obtained the PL emission spectrum of  $ZrO_2$  prepared by the sol-gel method obtained by using an excitation wavelength of 270 nm. This spectrum exhibits a single peak with its maximum emission centred at 370 nm. Figure 6 shows the excitation spectrum of  $ZrO_2$  obtained by using exciting light of 480 nm. Both emission and excitation spectra were obtained at room temperature. In figure 6, it can be seen that luminescent intensity of the beta-irradiated samples is higher than the luminescent intensity obtained from unirradiated samples. The PL excitation spectrum exhibits several peaks centred at around 390 nm when the samples were excited with light of 525 nm wavelength. However, the PL excitation spectrum consists of a single maximum emission centred at around 380 nm when the samples are excited with light of 480 nm wavelength.

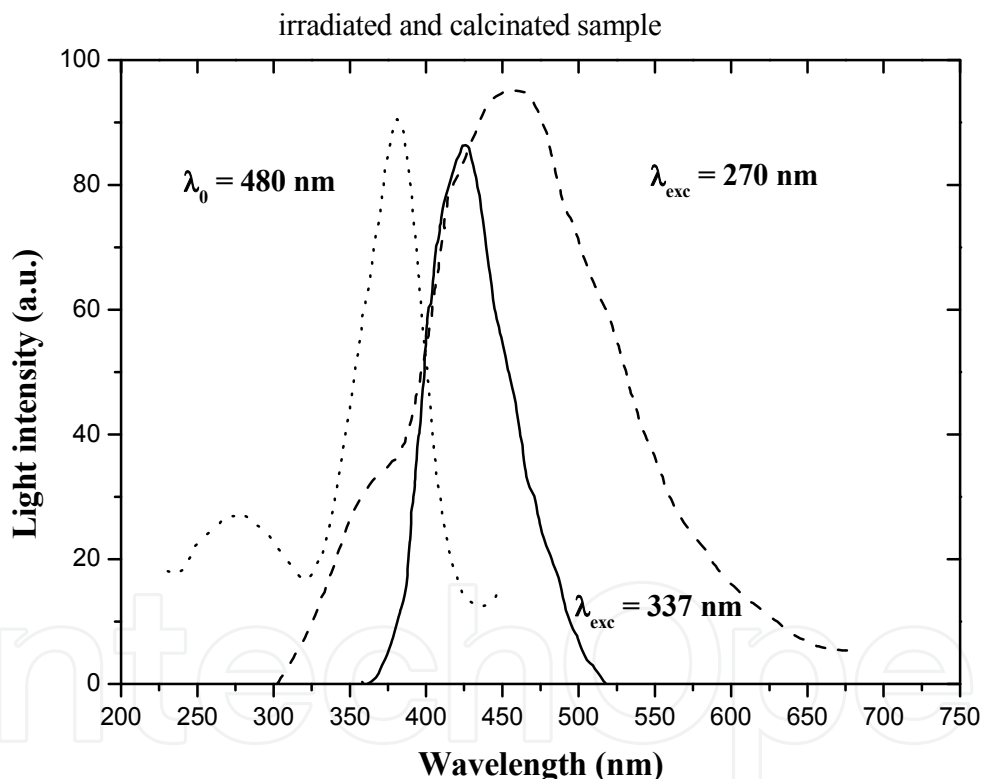

Fig. 6. Excitation spectrum of the intrinsic emission of polycrystalline  $ZrO_2$  at RT described by dotted line (....). PL emission spectra of polycrystalline  $ZrO_2$  powder samples for excitation wavelength of 270 nm described by dashed line (---). PL emission spectra of polycrystalline  $ZrO_2$  powder samples for excitation wavelength of 337 nm described by solid line (—) beta-irradiated samples.

This result suggests that the PL excitation peak of 337 nm is insight of the broad structure composed by the highest emission. Thus, taking into account these results, it can be

suggested that the emission excitation obtained is almost independent of the excitation wavelength used. Therefore, excitation wavelengths of 480 and 525 nm produce the emission peaks at 380 and 390 nm, respectively. Using these emission maxima the PL emission peaks centred at 370 and 430, respectively, can be obtained. These results indicate that ZrO<sub>2</sub> has two absorber centres and that the PL emission comes from ZrO<sub>2</sub> network. There are oxygen vacancies in ZrO<sub>2</sub> powder, which can induce the formation of new energy levels in the band gap. Then, the emission spectra can be divided into two broad categories. The first is due to those energy levels created by oxygen vacancies and the second broad peak is due to the deep level. For the TL phenomenon, this property is very important because the TL emission could be correlated to PL emission. Moreover, the TL glow curve of ZrO<sub>2</sub> exhibits two peaks. Thus, the defects responsible for the 370 nm emission might be correlated to the second TL peak at around 260°C. Meanwhile, the 400 nm emission could be correlated to the first TL emission peak. Thus the TL emission of the second peak could be a result of the electrons retrapped by deeper traps or because of the electrons already present in the deeper traps. This property is very important for the TL phenomenon because the TL emission could be correlated to photoluminescence emission.

### 5.3 Thermoluminescence in ceramics

Thermoluminescence (TL) or thermally stimulated luminescence (TSL) is the light emission after removal of the source of exciting energy light, x-rays, or other radiation; the free electrons may be trapped at an energy level higher than their ground state by application of thermal energy. The transition of electrons directly from a metastable state to ground state is forbidden (McKeever, 1985). The metastable state represents a shallow electron trap and electrons returning from it to the excited state require energy. This energy can be supplied in the form of optical radiation (photo stimulation) or as heat (thermal stimulation). The probability  $p$  per unit time that a trapped electron will escape from a metastable state to an excited state is governed by the Boltzmann equation.

$$p = s \cdot \exp(-E/kT) \quad (3)$$

where  $s$  is the frequency factor (sec<sup>-1</sup>), depending on the frequency of the number of hits of an electron in the trap which can be considered as a potential well,  $E$  is the thermal activation energy required to liberate a trapped charge carrier called trap depth (eV),  $k$  is Boltzmann's constant and  $T$  is the absolute temperature (K). First, the intensity of thermoluminescent emission does not remain constant at constant temperature, but decreases with time and eventually ceases altogether. Second, the spectrum of the thermoluminescence is highly dependent on the composition of the material and is only slightly affected by the temperature of heating. In the usual thermoluminescence experiments, the system is irradiated at a temperature at which the phosphorescence intensity is low, and later heated through a temperature range where the phosphorescence intensity is bright, until a temperature level at which all the charges have been thermally excited out of their metastable levels and the luminescence completely disappear (Chen & McKeever, 1997). The thermoluminescence emission mainly is used in solid state dosimetry for measurement of ionizing radiation dose.

#### 5.3.1 Mechanism of thermoluminescence

The details of the mechanisms of thermoluminescence phenomena with result in recombination luminescence are still not completely understood. The mechanism of

luminescence in semiconductor involves at least two steps: (i) first ionizing radiation (IR) induced defects both electron traps (ET) and hole traps (HT) which are created and, (ii) free electrons and holes are created in the conduction band and the valence band, with the subsequent emission of photons in the visible region spectrum. Thermoluminescence is the thermally stimulated emission of light from an insulator or a semiconductor following the previous absorption of energy from ionizing radiation.

The thermoluminescence process can be understood in terms of the band structure model of semiconductor. In a semiconductor there are two relevant energy bands: (i) an almost completely filled valence band (VB) and (ii) an almost empty conduction band (CB). The two energy bands are separated by a forbidden band gap (FB), which means that between these two bands there are no electronic energy levels. Transitions of electrons between the valence band and the conduction band are allowed and they produce free electrons in the conduction band and free holes in the valence band. The energy difference between the two bands is denoted by the band-gap energy  $E_g$  (see fig. 7).

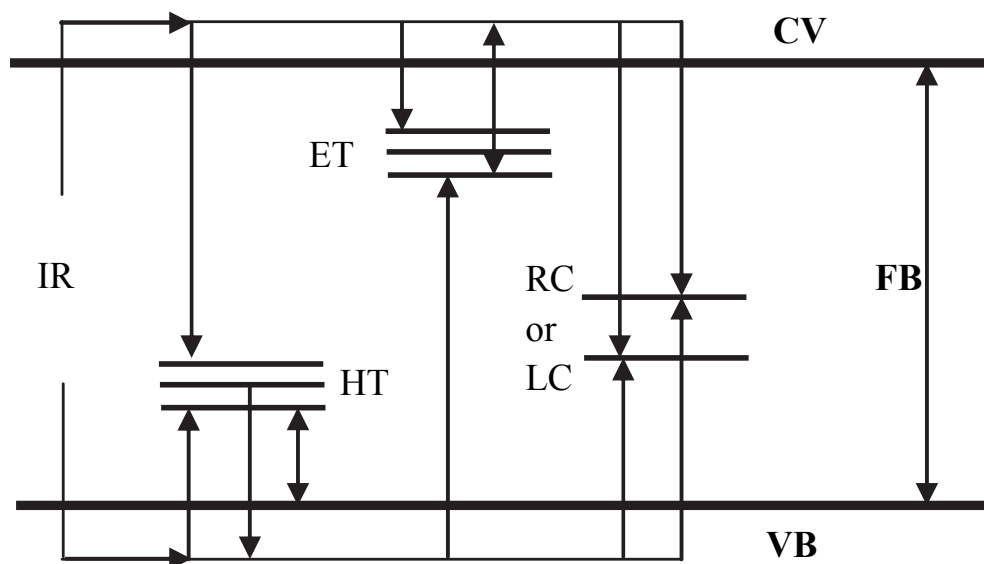

Fig. 7. Mechanism of the thermoluminescence process in a semiconductor

Due to ionizing radiation electrons are transferred from the valence band to the conduction band, which leads to the presence of significant concentrations of free electrons (in the conduction band) and free holes (in the valence band), in this case of electron-hole pairs case is created. To maintain electroneutrality of the crystal, for each electron, which is trapped at an electron trap a hole is produced, which might be trapped at a hole trap. During irradiation free electrons and holes can migrate in the crystal until they are trapped by impurities, luminescent centres and other imperfections in the crystal. Then the electrons and holes are (re-)distributed continuously over the available electron and hole traps (McKeever, 1985). After irradiation, the trapped electron or hole can be released is liberated from the trap by heating the crystal to moderate temperatures (optimum amount of thermal energy); it crosses a certain potential-energy barrier and when the electron recombines with a hole trapped at a recombination centre light is emitted ( $h\nu$ ) in the recombination process. A similar reasoning holds for the case of luminescence produced by recombination of free holes at the electronic recombination centres.

#### 5.4 Ceramic luminescence material

Phosphors for luminescent displays are commonly used in the form of powders. However, the role of particle size, shape, and crystallographic habit on excitation, quenching and emission is not understood. Fundamental studies which examine the fundamental luminescent characteristics of model particle systems of controlled purity, size and shape are necessary. The optical property has common applications in photochromic and colloid colored glasses (Wilkinson et al., 2004; Zhifa et al., 2010). Ceramics have found extensive applications in many important fields, such as thermal barrier coatings, laser coatings and hard overcoats. It is also considered a promising candidate for ionizing radiation dosimeter by means thermoluminescence phenomena (Brown et al., 1994).

#### 5.5 Thermoluminescence materials

Thermally stimulated luminescence or better known as thermoluminescence (TL) is a powerful technique extensively used for dosimetry of ionizing radiations. TL dosimeter (TLD) materials presently in use are inorganic crystalline materials (McKeever et al., 1995). They are in the form of chips, single crystals or microcrystalline size powder. The most popular are LiF:Mg,Ti, LiF:Mg,Cu,P, CaF<sub>2</sub>, Li<sub>2</sub>B<sub>4</sub>O<sub>7</sub>, CaSO<sub>4</sub>:Dy, CaF<sub>2</sub>:Dy (Azorín et al., 1993; Bhatt et al., 1997; Fox et al., 1988; Madhusoodanan & Lakshmanan, 1999). All materials described above are in microcrystalline sizes. However, with the use of very tiny particles such as nanoscale TLD materials, this problem is overcome to a major extent. The TL results of the recently reported nanomaterials have revealed very imperative characteristics such as high sensitivity and saturation at very high doses (Noh et al., 2001; Sahare et al., 2007; Salah et al., 2011). However, recent studies on different luminescent ceramic micro or nanomaterials showed that they have a potential application radiation dosimetry using TL technique (Azorín et al., 2007).

These materials spread over various applications such as medical imaging, high energy physics, and nondestructive testing. During the last two decades, numerous ceramic materials have been proposed to be used as radiation detectors. Among them, a lot of oxides materials have successfully been developed up to luminescent applications. In order to provide efficient dosimeters for X or  $\gamma$  rays, the choice of the oxide matrix is crucial. Since the first step of the detector mechanism involves absorption of energy photon, photoelectric absorption, Compton dispersion and creation pairs effect has to be favoured. Then, materials with high  $\rho \cdot Z_{\text{eff}}^4$  could be suggested. In this formulation,  $\rho$  is the density of the material and  $Z_{\text{eff}}$  is the effective atomic number defined as (Van Eijk, 1997).

$$Z_{\text{eff}}^4 = \sum_i w_i Z_i^4 \quad (4)$$

where  $w_i$  is the mass fraction of atom  $i$  and  $Z_i$  is its atomic number.

More recently, research focused more on improving the performances of known radiation detectors rather than developing new materials. It appears that a good way to improve detectors is to get a control of the material on a nanometric scale. It is indeed very important to control the dispersion of doping ions in the matrix and to control the size of the grains in case of powders. The possibility to prepare nanocrystalline powder could allow the preparation of ceramics that could replace traditional thermoluminescent material. Another very attractive solution is the direct preparation of radiation detecting thin films. Thin detecting films are particularly valuable in fundamental spectroscopic studies when the

absorption coefficient of the material is high or when the excitation energy is close to the absorption edge. They are also very interesting for high-resolution imaging where the film is required as a homogeneous coating. Both solutions provide low-cost substitutions for single crystals. The use of sol-gel processes for the preparation of luminescent ceramics seems to be a very interesting way to reach these objectives. In effect, the use of molecular precursors is the guarantee of very high chemical homogeneity which is usually also observed in the final material. Furthermore, the high versatility of the sol-gel process allows to reach various compositions and to vary the nature and the concentration of the doping ion easily.

## 6. Luminescent ceramic application

The nature and applications of optical luminescent ceramics have evolved rapidly in recent years. Their role as passive optical elements has been emerged by so-called photonic systems. These can have many active components oscillators, amplifiers, frequency and so on, most of which rely, to some degree, on optical field confinement (Kirm et al., 2005). The design of appropriate materials for this new technology involves progress on two separate levels. There is a need both for the optimization of microscopic electronic properties and for the separate control of bulk optical parameters on the scale of optical wavelengths (Lee & Rainforth, 1994). In the last years most of the work done in the Flat Panel Displays (FPD) area has been focused to the development of luminescent films based oxides of high quality, that can be applied as optically active layers in photoluminescent, cathodoluminescent and luminescent devices, for this purpose it is necessary to obtain flat and transparent films in order to obtain a device with a good resolution, contrast and efficiency characteristics (Chacon et al., 2008; Zhang et al., 2005). The optical ceramic preparing techniques were successfully developed in past years; the production of the transparent ceramic from ceramic nanopowders has high importance (Garcia et al., 1997; Gutzov & Lerch, 2003).  $ZrO_2$  (zirconia) is a widespread material due to large number of different applications, e.g., material for sensors, semiconductor devices, biocompatible material, and luminescent material. The luminescence of  $ZrO_2$  ceramics has been studied mainly for yttria-stabilized zirconia containing rare earth dopands and for mixed zirconia–alumina ceramics (Rivera et al., 2010b). The range of optical ceramic application is extended significantly since the transparent ceramic was sintered. The ceramic materials have some advantages over single crystals: easy fabrication, lower cost, large homogenous samples, and possibility to doping with rare earths elements.

Ceramic materials have been suggested for medical imaging in X-ray Computed Tomography (Moses, 1999; Van Eijk, 1997). The studies and developments of ceramic materials for detectors and scintillators are essential for many radiation dosimetry applications. Transparent ceramic materials with fast luminescence decay, low afterglow, high density (or radiation stopping power) and luminescence response in the visible region are required for technological applications. One of the promising materials for X and gamma rays detection is  $ZnO$  mainly for medical imaging. Another of the promising ceramic material for ionizing radiation and non ionising radiation dosimetry is  $ZrO_2$ . The luminescence results of  $ZrO_2$  is in spectral region obtained at room temperature, this spectrum covers the wide range (190–370 nm) of the TL excitation spectrum (Rivera et al. 1998), which in turn resembles the activation spectra of most of the UV-induced biological effects.

### 6.1 Ceramics in medicine

In recent years, bioceramics have helped improve the quality of life for millions of people. These specially designed materials (e.g. polycrystalline alumina or hydroxyapatite or partially stabilized zirconia, bioactive glass or glass-ceramics and polyethylene-hydroxyapatite composites) have been successfully used for the repair, reconstruction and replacement of diseased or damaged parts of the body, including bone (Roriz et al., 2010). Applications include orthopaedic implants (vertebral prostheses, intervertebral spacers, bone grafting), middle-ear bone replacements and jawbone repair (Chun et al., 2004; Emerich & Thanos, 2003,). For instance, alumina has been used in orthopaedic surgery for more than 20 years as the articulating surface in total hip prostheses because of its exceptionally low coefficient of friction and minimal wear rates. Microporous bioceramics based on calcium phosphate, with pores >100 to 150 microns in diameter, have been used to coat metal joint implants or used as unloaded space fillers for bone ingrowth (Kokubo, 2008). Ingrowth of tissue into the pores occurs, with an increase in interfacial area between the implant and the tissues and a resulting increase in resistance to movement of the device in the tissue. As in natural bone, proteins adsorb to the calcium phosphate surface to provide the critical intervening layer through which the bone cells interact with the implanted biomaterial (Flach et al., 1994).

Zirconia is used as a femoral head component in hip implants. High strength and high toughness allow the hip joint to be made smaller which allows a greater degree of articulation. The ability to be polished to a high surface finish also allows a low friction joint to be manufactured for articulating joints such as the hip. The chemical inertness of the material to the physiological environment reduces the risk of infection. Nanosized zirconium oxide should be is an ideal ceramic for dental applications because of its strength and transparency to light, but it is opaque to x-rays, making it an excellent material for UV-cured dental fillings (Stuart et al., 2007). The need for understanding of ceramic biological interfaces obviously extends to other applications of bioceramics (e.g., joint replacements, implants), although the specific needs are not addressed here. It should be stressed that collaboration with those in the dental and medical fields is essential for effective research in these areas.

### 6.2 Ceramics in radiation dosimetry

Since the discovery of X-ray by Rontgen and the concomitant use of the first dosimeter, research directed towards materials that can convert energy radiations (X-rays,  $\gamma$ -rays) into visible light, easily detectable with conventional detectors, is in constant development (Bhatt et al., 1997). A current interest of synthesizing and processing of advanced materials. The sol-gel technique is a low temperature method which uses chemical precursors to produce ceramics and glasses with better purity and homogeneity than the conventional high temperature processes. The sol-gel technique has been used to produce a wide range of compositions (mostly oxides) in various forms, including powders, fibbers, coatings and thin films, monoliths and composites, and porous membranes (Somiya et al., 1988). The sol-gel process to produce zirconia involves the hydrolysis and condensation of alkoxides. By controlling the synthesis conditions carefully, the sol morphology can be directed towards branched polymeric systems. Control of relative rates of hydrolysis and polycondensation, and the respective mechanisms of these reactions are the main tools for this difference

(Rivera et al., 2007c). This new preparation method of nanophosphors has been recently strongly developed for producing high efficiency luminescent materials. For the preparation of  $ZrO_2$  it is important to retain a high degree of crystallization and its possible correlation with the concentration of defects should be well-known. For this purpose new techniques to prepare well defined nanopowders have been used. A recent study on nanocrystalline  $ZrO_2$  obtained from amorphous zirconia demonstrated several unique features of nanocrystalline processing (Rivera et al., 2006).

Thermoluminescence (TL) is a very common technique used for dosimetry of ionizing radiation (Azorín, 1990). During TL, the energy absorbed by a phosphor previously exposed to ionizing radiation is released as light during the heating of the material. The intensity of light emitted by the phosphor is proportional to the irradiation dose given to it. Different preparation methods and properties of several TL materials have been studied so far and it was found that metal oxides doped with proper activators constitute a class of promising TL phosphors (Rivera et al., 2007a). The TL dosimetry (TLD) technique offers the advantage of being able to place the dosimeters in outdoor stations for solar radiation monitoring, without requiring any additional special monitoring or logistic considerations.  $ZrO_2$  is suggested by us as a suitable TLD material to accomplish this task. The luminescence of zirconia ceramics was not studied in detail and the comparison of single crystal, ceramic and nanopowder luminescence could be fruitful.

### 6.2.1 Ceramics for UV dosimetry

Pushing the limits of transparency in ceramic materials further into both the UV and the IR is of extreme importance in many applications. The humanity is constantly exposed to ultraviolet (UV) natural radiation reaching the surface of the earth. An important part of the UV spectrum is considered to be low energy ionising radiation. One of the former materials studied for possible use as a dosimeter is aluminium oxide ( $Al_2O_3$ ) (Colyott et al., 1997). Recently, for monitoring the ultraviolet radiation (UVR) different materials have been employed using the thermoluminescence (TL) method (Chang & Su 1992; Driscoll, 1996, Colyott et al., 1999). This technique has an advantage over other methods owing to the simplicity of the sample readout. Another advantage of this method and these phosphors include their small size, portability, lack of electrical power requirements, and linear response to the increasing radiation dose and high sensitivity (Van Dijken et al., 2000; Wang et al., 2005).  $ZrO_2$  was firstly proposed in 1990 as a TL material showing good dosimetric performances under the ultraviolet and visible light (Hsieh & Su, 1994; Rivera et al., 1998). Since then, several additional studies have been reported (Rivera et al., 2005a; 2005b; Azorín et al., 1999). Zirconium oxides have recently received considerable attention in view of its possible use as a TL dosimeter (TLD), if doped with suitable activators. These authors have been studied and developed thermoluminescent characteristics of various ceramics. Some of them were introduced into every day practice. For example, TLD pellets based on aluminium oxide are accepted and practically used in all applications. TLD pellets based on zirconium oxide and zirconium oxide doped with manganese and copper is developed to ultraviolet radiation dosimetry.

Pure oxides both monoclinic zirconia and  $\alpha$ -alumina have been studied after ultraviolet irradiation, before and after the thermal treatment at 1400°C under oxygen. TL glow curve of  $\alpha$ -alumina presents two peaks 260 nm after UV irradiation centred at 180°C and 350°C respectively. The monoclinic zirconia, which is discussed in mayor forms during this

chapter, the maximum peak is observed a change of positions, depending on the method preparation, when these are exposed to ultraviolet radiation. Thus, co-precipitation method gives the maximum at about 160°C. Sol-Gel method shows two peaks centred at 150°C and 230°C, respectively, with a maximum at about in 150°C. When compared by light output sum, the luminescent ceramic obtained by co-precipitation method demonstrate about one half efficiency of one obtained by Sol-Gel. In the case of alumina-zirconia mixtures is not response under UV irradiation.

### 6.2.2 Ceramics for ionising radiation dosimetry

The scientific study of thermoluminescence phenomena has an extremely rich history spanning many centuries and interacting with many other fields of endeavour: archaeology, geology, medicine, solid-state physics, biology and organic chemistry, to name just some of the mainstream areas of study. Many research groups are interested in thermoluminescence application to ionising radiation dosimetry as well as in the development of radiation response materials for solid state systems (Akselrod et al., 1990). These areas of endeavour are of major importance in fundamental questions of radiation medicine, which in turn can have great impact on questions concerning the future of radiation safety and the effects of interaction of radiation in matter, both beneficial and harmful, with the human organism. Although various thermoluminescent materials have been heretofore developed, practical uses of such materials has been limited due to numerous limitations in the materials themselves. For example, some materials require a relatively high energy input (light used to excite electrons) in order to trap a sufficient number of electrons to provide a relatively low afterglow effect. On the other hand, materials which are more efficient at trapping electrons may have trap depths which preclude room temperature level thermal energy from releasing the electrons and causing the light emission. Although the latter materials may be useful for other phenomena, such trap depths are not desirable or suitable for thermoluminescent material. Materials which have a very low electron trap depth do not store electrons sufficiently securely to allow an afterglow effect to last for an appreciable time after removal of the light or other energy used to excite the electrons. That is, the afterglow effect might be noticeable for a relatively short period of time (under one second), but the emission of light due to room temperature level of thermal energy may not be at all noticeable in such materials after a slightly longer period of time (10 seconds). The above and other limitations were disadvantageous of previously available thermoluminescent material has greatly limited the possible applications for using the phenomena of thermoluminescence. Additionally, the range of possible uses for thermoluminescent material has been limited by the restrictions in form of various thermoluminescent materials. As used herein, thermoluminescent material, shall refer to material having an afterglow which is perceptible by an unaided human eye and having a time duration depended upon the temperature. The large interest in TL as a technique for radiation dosimetry in environmental, personal and clinical applications pushes the research for producing new and high-performance TL materials. Zirconium oxides have recently received considerable attention in view of its possible use as a TL dosimeter (TLD), if doped with suitable activators.

The Thermoluminescent (TL) glow curve of zirconium oxide obtained by sol-gel method shows main maximum also was observed at different positions, depending on the source irradiation (see fig. 8). Thus, zirconium oxide beta irradiated (dashed line (---)) gives the



maximum at about 180°C. Zirconium oxide exposed to X-ray diagnostic beam (solid line (—)) shows two peaks centred at 160°C and 260°C, respectively, with a maximum at about in 260°C. In the figure, the second peak is the most prominent one and its amplitude is about 1.5 times that of the first peak.

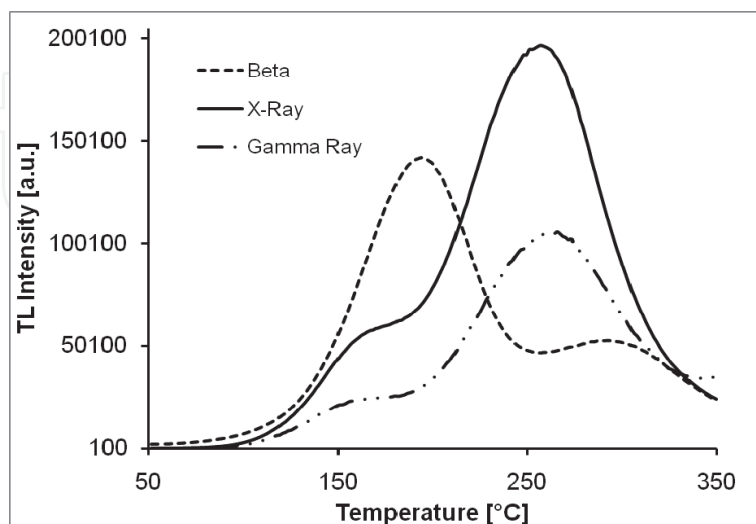

Fig. 8. TL response of  $ZrO_2$  exposed to photons and particles beams.

The shape of the glow curve remains almost the same for exposures between 2 and 100 Gy, but the relative heights of the two peaks change as a function of beta-absorbed dose; and zirconium oxide gamma irradiated (dashed and dotted line (-.-.-.-)) shows a TL glow curve very similar than obtained than that obtained by X-ray exposed. When compared by light output sum, the luminescent ceramic gamma irradiated demonstrate about one half efficiency than that one in X-ray exposed. TL sensitivity of zirconium oxide under beta irradiated demonstrates less sensitivity than those  $ZrO_2$  X-ray photon beams irradiations. The width of the main peak suggests that the activation energies of the traps form a continuous distribution. Thermoluminescent technique has an advantage over other methods owing to the simplicity of the sample readout. Other advantages of this method and these phosphors include their small size, portability, lack of electrical power requirements, linear response to the increasing radiation dose and high sensitivity. The large interest in TL as a technique for radiation dosimetry in environmental, personal and clinical applications pushes the research for producing new and high-performance TL materials.

Thermoluminescent (TL) response of ceramics as a function of ionising radiation absorbed dose depends on several factors. The simplest case is obvious: no side recombination and storage process, and the only kind of trapped state is involved into the energy storage. Nevertheless, side recombination processes are sometimes linear, and hence, can be present without affecting the linearity of the dose response. Then, the development of convenient thermoluminescent material with a good linearity requires very pure starting materials and rigidly controlled method preparation. Ceramics oxides (both aluminium oxide and zirconium oxide) are a good material for environmental dosimetry. They have a high sensitivity and linear dose dependence in a wide range of radiation doses for environmental monitoring. These ceramics show also good application for ionising radiation dosimetry in medical applications due to their wide range dose linearity. Rivera et al. (Rivera et al., 2007a) determined TL response of zirconium oxide as a function of ionising radiation absorbed

dose (e.g. gamma absorbed dose and beta absorbed dose). These authors obtained a good linearity in a wide range dose (see fig. 9). As it can be seen in figure,  $ZrO_2$  showed a linear response from 2 to 100 Gy denoted by full black square figures (■) after gamma irradiations. Meanwhile,  $ZrO_2$  under beta also exhibited a linear response at the same range dose which denoted by full black triangle (▲).

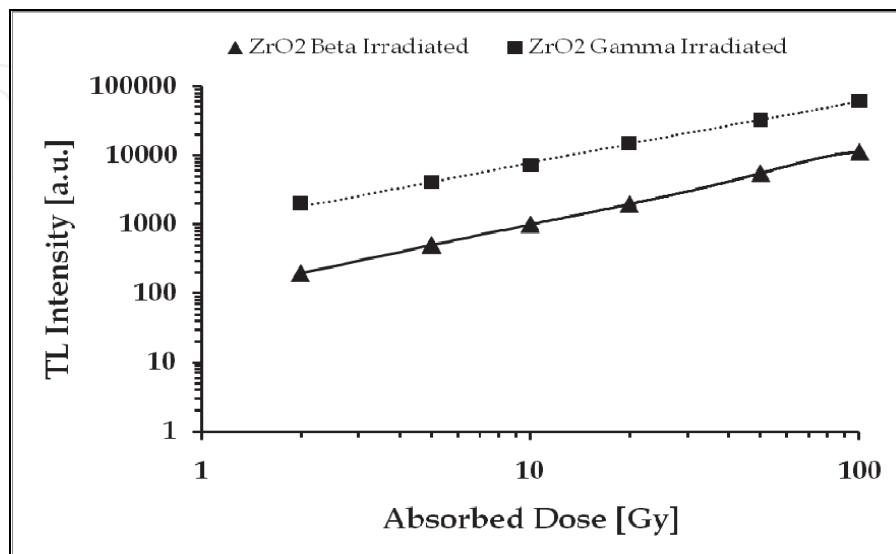

Fig. 9. TL response of ceramics as a function of IR absorbed dose

Reusability is one of the most important characteristics and another very useful property that a TL material should possess in order to be used in practical dosimetry. The Standard guide suggests reusability better than 5% standard deviation for those phosphors proposed to be used as TL dosimeter. In order to perform this test, the samples were exposed to 10 Gy of gamma absorbed dose; the TL glow curve recorded heating the samples up to 350°C at a heating rate of 10°C/s and then annealed. Several such cycles of exposure, glow curve recording and annealing were performed. No significant change in the intensity of both 160 and 260°C peaks were observed. Experimental results are shown in figure 10, confirming that reusability characteristics after 10 cycles of reading-irradiation was  $\pm 2.5\%$  S.D. (see fig. 10).

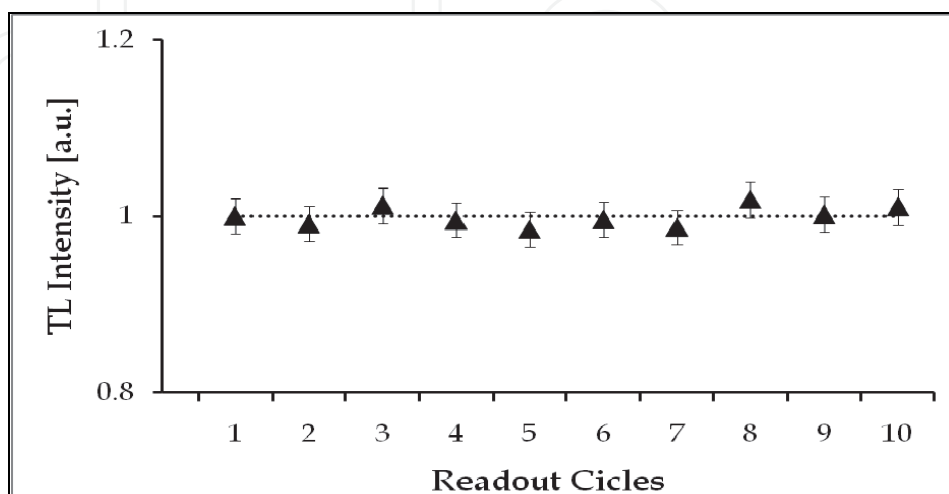

Fig. 10. Reproducibility of polycrystalline  $ZrO_2$  powder

If the samples have to be used in radiation dosimetry, their TL response must be stable and not fade appreciably upon storage after exposure. In order to check the stability characteristics of  $ZrO_2$ , several samples were irradiated and subsequently stored at RT in a dark place for a month. After storage it was found that the 260°C glow peak was quite stable.  $ZrO_2$  lost 30% of its information during the first 2 h after irradiation. After that, only 3% fading was observed during the next 30 days, indicating no serious fading problem for dosimetric applications.

### 6.2.3 Dopant effect on ceramics

Solid-state band theory provides a way to explain the luminescence phenomenon. This explanation consist in an insulating solid material with forbidden gap, in this there are metastable states where electrons are trapped when insolate is excited. If the energy lost when the electrons are vacated from the traps is emitted in the appropriate energy or wavelength range, luminescence will result. There are several possible kinds of the traps can to produce luminescence. If the luminescence is produced by structural imperfections which are characteristics of the host lattice is called intrinsic luminescence (Asiltürk et al., 2011; Bourgoin & Lannon, 1983; Li et al., 1995). Extrinsic luminescence is another kind of luminescence which results from impurities in the structure. The impurities generate luminescent centres and are most commonly transition elements, rare earth elements and actinide elements (due to the occurrence of valence electrons in either "d" or "f" orbital). These impurities are generally the most common source of luminescence in ceramics (Bao et al., 2007; Ekambaram, 2005; Jung et al., 2005). Some of these impurities are trace elements that promote luminescence in a ceramic material (substitutional). In general, the intensity and wavelength of the luminescence is dependent on the electron configuration of the activator ion and the nature of the lattice that holds the ion luminescence (Ming & Tang, 2011). These dopants present in thermoluminescent phosphors induce higher luminescence efficiency either due to better incorporation of activator ions or due to improvement in energy transfer processes (Rivera et al., 1999). Doping with ion activators of the thermoluminescent phosphors resulted in increasing the TL sensitivity from 1.2 to 3.4 times, when compared with that of the TL phosphors without ion dopant (Rivera et al., 2007d; J. Zhang et al., 2002). It is observed that the addition of ion dopant induces in some TL phosphors enhancement of the higher temperature peak which is correlated with the increase of TL sensitivity. The high TL output of these TL phosphors could be used in dosimetric practice for special short-term measurements.

The substitution of impurities ions into insulating host crystals introduces lattice strains and, for non-trivalent sites, a need for charge compensation. Such effects alter the site symmetry and this is reflected in properties such as the wavelength, line width, lifetime and relative intensity of the ion transitions. The ions are variously incorporated as substitutional ions, pairs, clusters, or even as precipitates of new phases, but the detailed modelling is often speculative. There are numerous differences in glow peak temperature, for nominally the same defect sites, which are thought to indicate charge trapping and recombination within coupled defect sites, or within a large complex. Size and cluster effects can be modified by heat treatments (Rivera et al., 2007b). Other impurities inhibit or eliminate thermoluminescence in a material intensity; this effect is known as quenching. The fact can be seen that both TL glow peaks reach the maximum when the activators Cu is introduced into ceramic matrix, and the TL intensity is reduced still 3 times than that obtained with the

ceramic without impurity as well as reported by Rivera et al (Rivera et al., 2007b). This effect may be attributed to a lattice distortion. When the dopant atoms with large radius come into matrix lattice, the lattice will be distorted. The fact can be found out in Figure 11 that the intensity of low energy emission band is reduced and that of high energy emission band is enhanced with the presence of copper ion ( $\text{Cu}^+$ ); on the contrary, the intensity of low energy emission band is enhanced and that of the high energy one is reduced with the presence of dopant Mg. Lattice distortion effect is shown by Rivera when  $\text{ZrO}_2$  ceramics were exposed to UV radiation. They reported their results and plotted in figure 11. In this figure, as it can be seen TL glow curve of  $\text{ZrO}_2$  exhibited two peaks at around 90 and 160°C denoted by line solid (—). The TL glow curve of  $\text{ZrO}_2$  doped with copper (Cu) and magnesium (Mg) showed a single peak.  $\text{ZrO}_2:\text{Mg}$  ceramics exhibited a main peak centred at around 130°C denoted by dotted line (···). Meanwhile,  $\text{ZrO}_2:\text{Cu}$  exhibited one peak centred at around 180°C denoted by dashed line (---). The position of the peak is shifted for about 50°C.

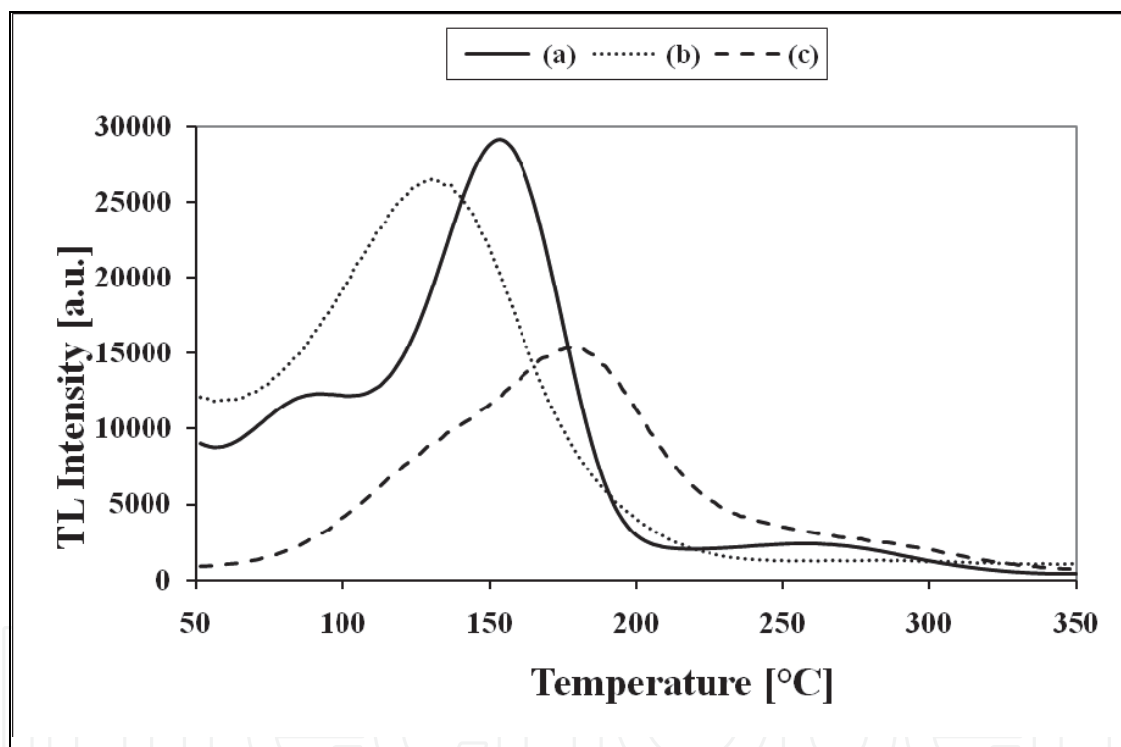

Fig. 11. Effect of dopant in  $\text{ZrO}_2$  ceramics exposed to UV radiation

Ceramics oxides doped with impurities are a good material for environmental dosimetry. They have a high sensitivity and linear dose dependence in a wide range of ultraviolet radiation doses for UV monitoring; this effect was confirmed by Rivera et al. (Rivera et al., 2007b). They obtained experimental results zirconium oxide doped with various dopants ( $\text{ZrO}_2:\text{VD}$ ) as a function of UV radiation analyzed by thermoluminescence phenomena (see fig. 12). In this figure shows this TL response as a function of spectral irradiance. It can be seen,  $\text{ZrO}_2:\text{Mg}$  showed a linear response from 50 to 4600  $\text{mJ}/\text{cm}^2$  denoted by full black square figures (■). Meanwhile,  $\text{ZrO}_2:\text{Cu}$  exhibited a linear response from 20 to 2400  $\text{mJ}/\text{cm}^2$  denoted by full black circle (●).

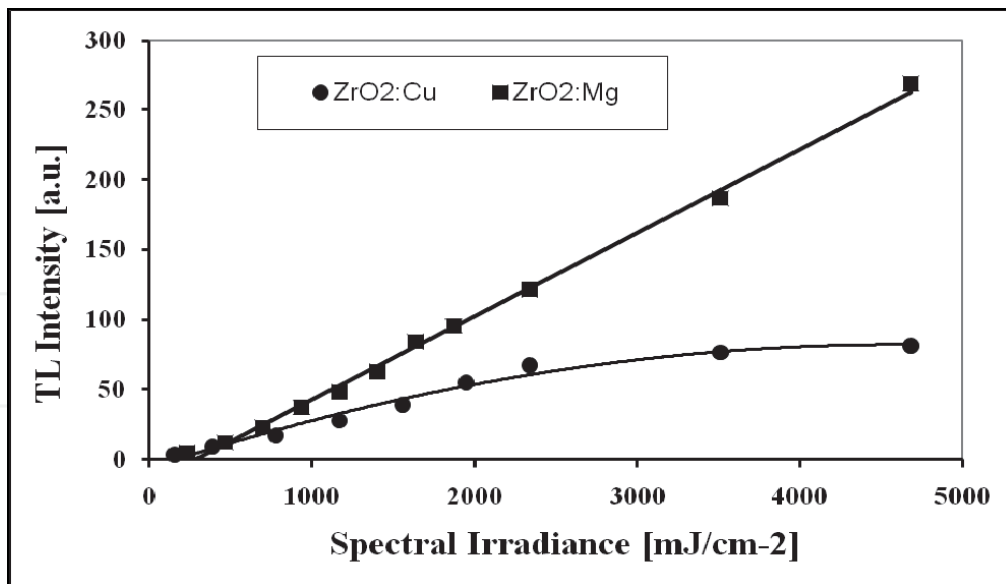

Fig. 12. TL response of  $ZrO_2$  as a function of spectral irradiance of UVR

The same authors also studied the dopants effect in ceramics when are submitted under ionising radiation field. They concluded glow peak shifted is correlated of kind of dopant in ceramics matrix (see fig. 13). In this figure zirconium oxide doped with cooper and magnesium was irradiated with beta radiation. As it can be seen in figure 13, TL glow curve of  $ZrO_2$  denoted by dotted line (...) exhibits two peaks centred at around of 160 and 260°C respectively, when this is submitted to an absorbed dose up to 10 Gy. As absorbed dose is increased up to 10 Gy a second peak appeared at around 260°C.

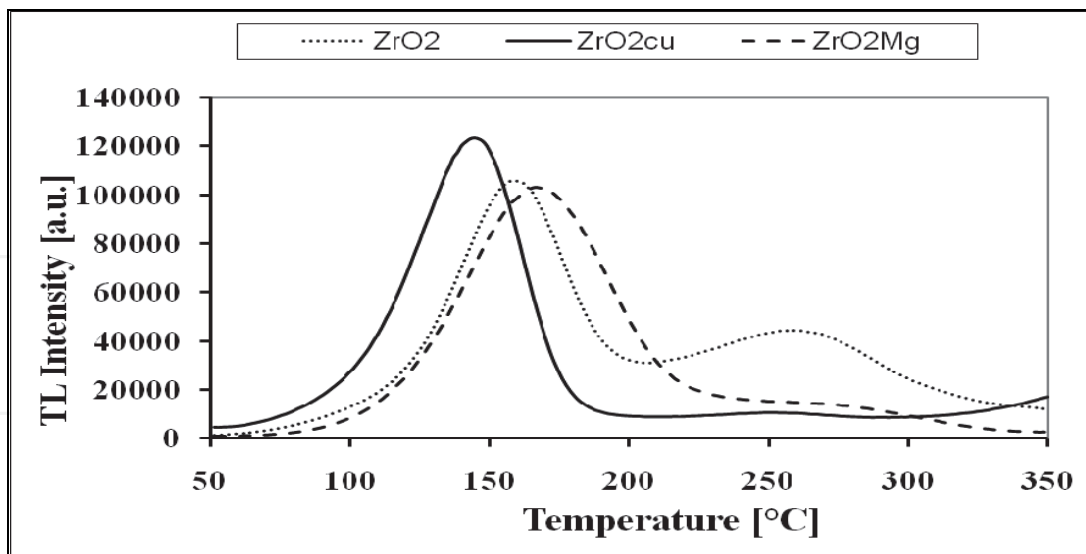

Fig. 13. Effect of dopants in ceramics beta irradiated

The TL glow curves of  $ZrO_2:Mg$  denoted by dashed line (---) has just one peak centred at around of 180°C. Ceramic of zirconium oxide doped with cooper ions ( $ZrO_2:Cu$ ) denoted by solid line (—) also show one main peak centred at around 130°C. As absorbed dose is increased a second peak appeared at around 250°C. The first peak of the zirconium oxide doped with dopants is shifted for about 50°C; this effect is attributed to the dopant ions. The

TL glow curves can be conceived as composed by many closely spaced peaks resulting in a broad TL curve in which individual peaks cannot yet resolved. The shape of the glow curve for all samples remains almost the same for all irradiation exposures; however, the relative peak heights change as a function of radiation dose.

TL response as a function of beta absorbed dose is also analyzed by Rivera et al. They show zirconium oxide doped with cooper ( $ZrO_2:Cu$ ) exhibits a linear response from 2 to 35 Gy (see fig. 14) which is denoted by solid line (—) and TL response of zirconium oxide doped with magnesium ( $ZrO_2:Mg$ ) as a function of beta irradiation, which exhibited linearity from 2 to 35Gy. Each experimental data point represents the average response over five irradiated pellets.

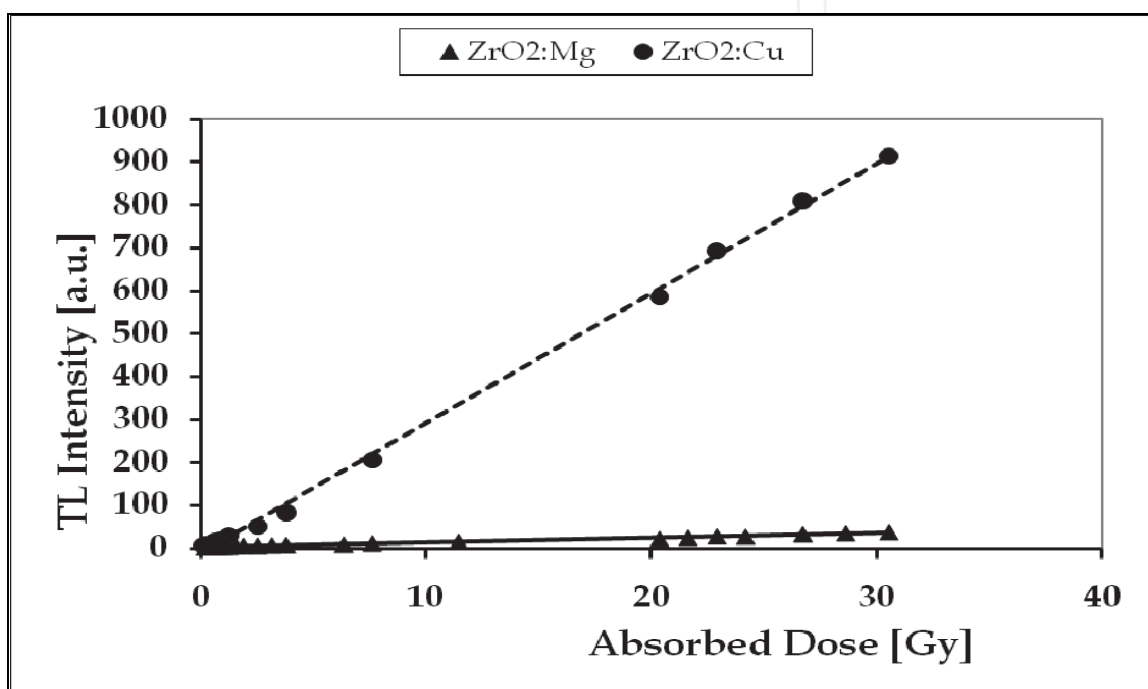

Fig. 14. TL response of  $ZrO_2$  as a function of beta dose

### 6.3 Ceramic material for the 21th century

Nanotechnology can be defined as the science and engineering involved in the design, synthesis, characterization and luminescent application of ceramic materials and devices whose smallest functional organization in at least one dimension is on the nanometer scale (Emerich & Thanos, 2003). The genesis of nanotechnology can be traced to be promise of revolutionary advances across in medicine, medical physics, biomedical, and robotics.

Nanotechnology covers a broad range of fundamental and applied topics in the field of oxide ceramics, such as novel processing techniques and equipment; solidification and crystal growth; analysis and characterization; structural ceramics; mechanical properties and applications; defect transport and related phenomena; modelling of processes and properties; advances in electro-ceramics; oxide based ceramics for energy applications; applications and development of porous ceramics; nano-structured oxide ceramics; functional oxides and applications; transparent and luminescent ceramics. In semiconductor area, nanostructured semiconductors will be developed ceramics with non-linear optical properties, with quantum confinement effects which may lead to special properties, like the

luminescence in silicon powders and silicon germanium quantum dots as infrared optoelectronic devices. Nanotechnology optoelectronics will be the most attractive nanophosphors development for high-definition television and flat panel displays. This, opening the way for optoelectronic chips and possibly new type of colour displays. Also efficient light-emitting diodes based on quantum dots with a voltage-controlled, tuneable output colour. In optics glass ceramics will acquire importance in graded refractive index (GRIN) optics for developing of special plastic lenses or inexpensive colored glasses and optical filters.

Applications of ceramics in medicine are specially promising and areas as diagnosis imaging treatment of tumours. In biomedical, nanostructural ceramic materials with sizes 1 to 100 nm can act as new and effective constituents of bone materials. Besides the ceramic applications in medical diagnostic instruments, the field of bioceramics for bone replacement and chemotherapy release capsules is here. As ceramic materials improve in terms of strength, nonreactivity, compatibility, longevity, porosity for tissue growth, and lower costs, more use of ceramic devices will be seen. Several studies have reported improved osseointegration on nanostructure surfaces created from ceramics (Chun et al., 2004). Noninvasive imaging techniques have had a major impact in medicine over the past 25 years or so. The current drive in developing techniques such as functional magnetic resonance imaging (MRI) is to enhance spatial resolution and contrast agents. Computed tomography (CT) is a medical imaging technique that has become an important medical diagnostic tool over the last 15 years. This technique reconstructs cross-sectional images of the body and head by scanning the patient with X-rays. Body tissues and bones intersected by the X-ray beam can be imaged. In addition to medical applications, CT is being used for industrial inspection of aircraft engine components. At the heart of a CT system is the detector, consisting of a number of scintillator elements (Kirm et al., 2005). A scintillator is made out of a solid state luminescent material that converts high energy radiation into useful visible light. A ceramic material based on a combination of rare earth oxides (e.g.  $\text{Eu}^{3+}$ ,  $\text{Tb}^{3+}$ ,  $\text{Ce}^{3+}$ ,  $\text{Dy}^{3+}$ ) has been suggested that meets these requirements. In addition to being transparent, the material has an absorption efficiency of 99%, scintillation efficiency three times that of conventional detector materials. The afterglow property of this material is very low in crisp edge definition that is maintained between acquired views during scanning. This property is necessary in order to produce smoother, sharper images and superior low contrast detection without the risk of increased radiation dose to the patient. Thus, a more accurate and safer diagnosis can be made. Further research will lead to ceramic scintillators with higher X-ray stopping power, faster speeds and lower costs that can be tailored to specific applications. Whether used for imaging the human body or aircraft parts, such improvements can only result in more saved lives.

The radiation dosimetry in medical physics applications will be revolutionized with the development of optic fibres. Development of optical fibres luminescent technique and microminiaturization of components will come the incorporation of optical luminescent ceramics to real time in vivo dosimetry. Nanocrystalline ceramics developing and enhancement luminescent properties promise as a good candidate for high dose measurements. Crystalline ceramics will be used in nuclear accident where retrospective dosimetry is urgently required in order to advance epidemiological studies of the population.

## 7. Conclusion

In this chapter synthesis and luminescent characterization properties of ceramics using thermoluminescent phenomena were analyzed. In this chapter an enhancement of luminescence property in ceramics is attributed to dopant ions effect. The position change of the TL glow peaks is attributed to preparation method. It changes observed in many nanostructured materials that the energy level bands are altered or reorganized to the dopant ions effect could be due to the creation vacancy into the crystal field effects. The change of the position of the main peaks as function excitation energy (e.g. UV radiation, X-rays or gamma rays) is observed in these ceramics. It changes observed in many nanostructured materials that the energy level bands are altered or reorganized to the particle size effect could be due to the absence of crystal field effects. This change may be attributed to creation of vacancy effect due to radiation energy, trap distribution and cross section of the absorber materials. It is known that on decreasing the particle size to nanoscale, the band gaps are widened. Due to the widening of the bandgap, the energy levels of the host of ceramics doped with dopant might also get reorganized. On irradiation to high-energy radiation, the population of the trapping or luminescent centers (TC or LC) get change, this effect should be reflected on the occurrence of different intensities for the TL glow peaks. According to this effect, the number of traps generated by the high-energy radiation in the traps depends not only on the cross-section of the traps but also on the deep of the traps inside the matrix. It is evident that in the case of a single crystal or a microcrystalline powder, high-energy radiation (such as gamma rays or x-ray beams accelerated having energy of the order of MeV) could generate a track of approximate length equal to dimensions of the crystal or crystallites while penetrating through it. This could be of the order of several mm. But in the case of nanocrystallites, the length of such tracks will be only of the order of few tens of nanometers (dimensions of the nanoparticles). If it, therefore, compares the number of TC or LC generated in the nanocrystalline it would be much less than that in the case of a single crystal or microcrystalline powder sample for low doses. However, as the dose increases, more overlapping tracks occur, which might not give extra TL and saturation occurs in the case of a single crystal or microcrystalline powder material. However, in the case of nanoparticles, there still exist some particles that would have been missed while being targeted by the high-energy radiation, due to the very tiny size of the particles. Other, advantages of the nanoparticles is the slow down the process of generating the competing traps at different levels, giving rise to a somewhat low sensitivity but a good linearity over a very wide range of doses. From the application point of few, the easy method of preparation, good sensitivity, simple glow curve structure and TL response over a wide range of exposure are some of the good characteristics of the presented luminescent ceramic nanopowders. Therefore, it might be used as a dosimeter for low as well as high doses of ionizing radiations that has several applications such as medical physics.

## 8. References

- Agarwal, M.; De Guire, M. R. & Heuer, A. H. (1997). Synthesis of ZrO<sub>2</sub> and Y<sub>2</sub>O<sub>3</sub>-doped ZrO<sub>2</sub> thin films using self-assembled monolayers. *American Ceramics Society*, Vol. 80, pp. 2967-2981.



- Aguilar, D. H.; Torres, L. C.; Torres, L. M.; Lopez, T.; Quintana, P. (2001). A Study of the Crystallization of  $ZrO_2$  in the Sol-Gel System:  $ZrO_2-SiO_2$ . *Solid State Chemistry*. Vol. 158, No. 2, pp. 349-357.
- Akselrod, M. S.; Kortov, V. S.; Kravetsky, D. J. & Gotlib, V. I. (1990). Highly Sensitive Thermoluminescent Anion Defect  $\alpha-Al_2O_3$ :Single Crystal Detector. *Radiation Protection Dosimetry*. Vol. 32, pp.15-20.
- Asiltürk, M.; Burunkaya, E.; Sayilkan, F.; Kiraz, N.; Arpaç E. (2011). Structural and optical properties of thin films prepared from surface modified  $ZrO_2$ . *Journal of Non-Crystalline Solids*. Vol.357, No. 1, pp. 206-210.
- Azik, P.; Głuchowski, R.; Hreniak, P.; Strek, D.; W., Ro's, M., Fedyk, R. & Łojkowski, W. (2008). Fabrication and luminescence studies of  $Ce:Y_3Al_5O_{12}$  transparent nanoceramic. *Optical Material*. Vol. 30, pp. 714-718.
- Azorín, J.; Khaidukov, N.M.; Sánchez, A.; Rivera, T. (2007). Thermoluminescence properties of  $TiO_2$  nanopowder. *Radiation Measurement*. Vol. 42, pp. 613-616
- Azorín, J.; Rivera, T.; Falcony, C.; Martínez, E. & García, M. (1999). Ultraviolet Thermoluminescent Dosimetry Using Terbium-doped Zirconium Oxide Thin Films. *Radiation Protection Dosimetry*. Vol. 85, pp. 317-319.
- Azorín, J.; Rivera, T.; Martínez, E; & García, M. (1998). Thermoluminescence of Eu-doped  $Zr_2O$  thin films to Ultraviolet and Visible Light. *Radiation Measurements*. Vol. 29, pp. 315-317.
- Azorin, J.; Furetta, C.; Scacco. A. (1993). Preparation and properties of thermoluminescent materials. *Physica Status Solidi (a)*. Vol. 138, No. 1, pp. 9-46
- Azorín, J. *Luminescence Dosimetry. Theory and Applications*. (Ediciones Técnico Científicas, México 1990)
- Bao, A.; Tao, C.; Yang, H. (2007). Synthesis and luminescent properties of nanoparticles  $GdCaAl_3O_7:RE^{3+}$  ( $RE=Eu, Tb$ ) via the sol-gel method. *Journal of Luminescence*. Vol. 126, No. 2, pp. 859-865.
- Bhatt, B.C.; Sanaye, S.S.; Shinde, S.S.; Srivastava, J.K. (1997). A Comparative Study of the Dosimetric Characteristics of  $BaSO_4:Eu$  and  $CaSO_4:Dy$  Teflon TLD. *Discs. Radiation Protection Dosimetry*. Vol. 105, pp. 105-110.
- Bourgoin, J. & Lannon, M. (1983). *Points Defects in Semiconductors Experimental Aspects*. Springer, Berlin, Heidelberg, New York.
- Brinker, C.J. & Scherer, G.W. (1990). *Sol-Gel Science: The Physics and Chemistry of Sol-Gel Processing*, Academic Press, inc. San Diego, CA.
- Brinker, C.J. & Sherrer, G. (1989). *Sol-Gel Chemistry, the Physics and Chemistry of Sol-Gel Processing*. Academic Press, San Diego.
- Brown, C.K.; Bolch, W.E. & Porton, J.W. (1994). Characterization of  $Al_2O_3:C$  Thermoluminescent Dosimeter Response to Beta-Radiation. *Radiation Protection Managment*. Vol. 11, pp. 30-40
- Chacon C.V., Guzman, J.; Aguilar, M.A.; Garcia, M.; Alvarez, O. & Falcony, C. (2008). Characterization of luminescent samarium doped  $HfO_2$  coatings synthesized by spray pyrolysis technique. *Journal of Physics D: Applied Physics*. Vol. 41, No. 1, pp. 15104.

- Chang, S.C. & Su, C.S. (1992). Direct thermoluminescence of sintered ZrO<sub>2</sub> pellets induced by ultraviolet. *Radiation Nuclear Tracks Radiation Measurement*. Vol. 20, No. 3, pp. 511-516.
- Chang, S.C. & Su, C.S. (1993). Influence of the sintering process of ZrO<sub>2</sub> pellets on thermoluminescence induced by ultraviolet radiation. *Radiation Protection Dosimetry*. Vol. 47, No. 1-4, pp. 689-692.
- Chen, R. & McKeever, S.W.S. (1997). *Theory of Thermoluminescence and Related Phenomena*. World Scientific Publications Singapore.
- Chun, A.L.; Moralez, J.G.; Fenniri H.; Webster, T.J. (2004). Helical rosette nanotubes: a more effective orthopedic implant material. *Nanotechnology* Vol. 15. pp. s1-s6
- Colyott, L.E.; Akselrod, M.S.; McKeever, S.W.S. 1997. An integrating ultraviolet-B dosimeter using phototransferred thermoluminescence from Al<sub>2</sub>O<sub>3</sub>:C. *Radiation Protection Dosimetry*. Vol. 72, No. 2, pp. 87-94.
- Colyott, L.E.; McKeever, S.W.S.; Akselrod, M.S. 1999. An integrating UVB dosimeter system. *Radiation Protection Dosimetry*. Vol. 85, No. 1-4, pp. 309-312.
- Deis, T.A. & Phule, P.P. (1992). Preparation of oriented lithium tantalate thin films using molecularly modified tantalum(V) ethoxide and lithium acetate. *Materials Science Letters*. Vol. 11, pp.1353-1355.
- De Lange, R.S.A.; Hehink, J.H.A.; Kelzer, K.; Burggraaf, A.J. (1995). Synthesis and characterization with SAXS *Journal of Non-Crystalline Solids*. Vol. 191, pp. 1-16.
- Diaz, M.A.; Luff, B.J.; Townsend P.D. & Wirth, K.R. (1991). Temperature dependence of luminescence from zircon, calcite, Iceland spar and apatite. *Radiation Applications and Instrumentation. Part D. Nuclear Tracks and Radiation Measurements*. Vol. 18, No. 1-2, pp. 45-51
- Driscoll, C.M.H. 1996. Solar UVR measurements. *Radiation Protection Dosimetry*. Vol. 64, No. 3, pp.179-188.
- Ekambaram, S. (2005). Effect of host-structure on the charge of europium ion. *Journal of Alloys and Compounds*. Vol. 390, No. 1-2, P. L1-L3.
- Emerich, D.F. & Thanos, C.G. (2003). Nanotechnology and medicine. *Expert Opin Bio Ther*. Vol. 3, P. 655-63
- Ferey, F.; Grosseau, P.; Guilhot, B.; Iaconi, P.; Benabdesselam, M. (2001). Thermoluminescence and sintering of high purity  $\alpha$ -alumina doped by Zr, Th and Ca. *Solid State Ionics*. Vol. 141-2, pp. 567-74
- Flach, J.S.; Shimp, L.A.; Blitterswijk, C.A. & Groot, K. (1994). A calibrated method for crystallinity determination of hydroxylapatite coatings for implants. Characterization and performance of calcium phosphate coatings for implants, ASTM STP 1196, Emanuel Horowitz and Jack E. Parr, ASTM, Philadelphia. pp. 25-32.
- Fox, P.J.; Akber, R.A.; Prescott, J.R. (1988). Spectral Characteristics of Six Phosphors Used in Thermoluminescence Dosimetry. *Journal of Physics. D*. Vol. 21, pp. 189-194.
- Furetta, C. & Weng P.S. (1998). *Operational Thermoluminescence Dosimetry*. World Scientific Publishing Co.
- Garcia, M. A.; Paje, S. E. and Llopis, J. (1997). Luminescence of ZTA ceramics. *Journal of Luminescence*. Vol. 72-74, pp. 662-663.

- German, R. M. (1996). *Sintering Theory and Practice*. John Wiley & Sons, Inc. USA.
- Gitzen, W. H. (1998). *Alumina as a Ceramic Material*. The American Ceramic Society, Special Publication No. 4, Westerville Ohio.
- Gutzov, S. & Lerch, M. (2003). Optical properties of europium containing zirconium oxynitrides. *Optical Material*. Vol. 24, pp. 547-554.
- Guzmán, J.; Aguilar, M.A.; Alarcón, G.; García, M.; Azorín, J.; Rivera, R.; Falcony C. (2010). Synthesis and characterization of hafnium oxide films for thermo and photoluminescence applications. *Applied Radiation and Isotopes*. Vol. 68 pp. 696-699.
- Hassan, F.; Abdel, S.; Abdel, M.; Abd, N.; Ahmed, S.; Kato, S.; Kojima, T. (2009). Crystallization behaviour and hardness of glass ceramics rich in nanocrystals of ZrO<sub>2</sub>. *Ceramics International*. Vol. 35, No. 3, pp. 1133-1137.
- Hernández, J.M.; Cortez, L.A.; García, R.; Castillo, A.; Sandoval, G.; García, L.A. (2009). Synthesis and characterization of mesoporous and nano-crystalline phosphate zirconium oxides. *Journal of Alloys and Compounds*. Vol. 483, No. 1-2, pp. 425-428.
- Heuer, A.H. & Hobbs, L.W. (Eds.), (1981). *Science and Technology of Zirconia, Advances in Ceramics*. Vol. 3, American Ceramic Society, Columbus OH.
- Hideo, T.; Yoshimura, M.; Somiya, S. (2006). Calibration Curve for Quantitative Analysis of the Monoclinic-Tetragonal ZrO<sub>2</sub> System by X-Ray Diffraction *American Ceramic Society*. Vol. 67, No. 6, pp. 119-121
- Hsieh, W.C. & Su C.S. (1994). UV Induced Thermoluminescence in ZrO<sub>2</sub> Doped by Er<sub>2</sub>O<sub>3</sub>. *Journal of Physics D: Applied Physics*. Vol. 27, pp. 1763-1768
- Jacobsohn, L.G.; Tornga, S.C.; Bennett, B.L.; Muenchausen, R.E.; Ugurlu, O.; Tseng T.K.; Choi, J.; Holloway, P.H. (2010). Annealing effects on the photoluminescence yield of Gd<sub>2</sub>O<sub>3</sub>:Eu nanoparticles produced by solution combustion synthesis. *Radiation Measurements*. Vol. 45, No. 3-6, pp. 611-614.
- Jung, K.Y.; Woo, H.; Chan, Y.; Bin, S. & Suk, Y. (2005). Luminescent Properties of (Ba,Sr)MgAl<sub>10</sub>O<sub>17</sub>:Mn,Eu Green Phosphor Prepared by Spray Pyrolysis under VUV Excitation. *Chemistry of Materials*. Vol. 17, No.10, pp. 2729-2734.
- Keller, L. (1995). X-ray Powder Diffraction Patterns of Calcium Phosphates Analyzed by the Rietveld Method. *Biomedical Materials Research*. Vol. 29, pp. 1403-1413.
- Kirm, M.; Aarik, J.; Jurgens, M. & Sildos, I. (2005). Thin films of HfO<sub>2</sub> and ZrO<sub>2</sub> as potential scintillators. *Nuclear Instruments Methods in Physics Resesearch A*. Vol. 537, pp. 251-255.
- Kokubo, T. (2008). *Bioceramics and their clinical applications*. Woodhead Publishing, Cambridge, U.K.
- Kumar, P.M.; Borse, P.; Rohatgi, V.K.; Bhoraskar, S.V.; Singh, P.; Sastry, M. (1994). Synthesis and structural characterization of nanocrystalline aluminium oxide. *Materials Chemistry and Physics*. Vol. 36, No. 3-4, pp. 354-358.
- Langlet M. & Joubert J.C. (1993). *Chemistry of Advanced Materials*, edited by C.N.R. Rao (Blackwell Science, Oxford, UK).
- Lee, D. & Rainforth W.M. (1994). *Ceramic microstructures property control by processing*, Chapman & Hall, 3

- Li, C.; Chen, Y.W.; Yen, T.M. (1995) The effects of preparation method on the characteristics of alumina-zirconia powders. *Sol-Gel Science Technology*. Vol. 4, pp. 205-10.
- Lochab, S.P.; Pandey, A.; Sahare, P.D.; Chauhan, R.S.; Salah, N.; Ranjan, R. (2007). Nanocrystalline  $\text{MgB}_4\text{O}_7:\text{Dy}$  for high dose measurement of gamma radiation. *Physica Status Solidi. A*. Vol. 204, pp. 2416-2425.
- Madhusoodanan, U. & Lakshmanan, A.R. (1999). Development of  $\text{BaSO}_4:\text{Eu}$  thermoluminescence phosphor. *Radiation Measurements*. Vol. 30, pp. 65-72.
- McKeever, S. W. S.; Moscovitch, M. & Townsend, P. D. (1995). *Thermoluminescence Dosimetry Materials: Properties and Uses* (Ashford: Nuclear Technology Publishing).
- McKeever, S.W.S. (1985). *Thermoluminescence of Solids*. (Cambridge University Press, Cambridge)
- Ming, Y. & Tang, Y. (2011). Effect of Dy Ions on Optical Properties of  $\text{Sr}_{0.985-x}\text{Al}_2\text{O}_4:\text{Eu}^{2+}_{0.015}\text{Dy}^{3+}_x$  Phosphors. *Materials Science Forum*. Vol. 663-665, pp. 84-87.
- Mishra, K. C.; Di Bartolo, B.; Collins, J. M. (2011). Luminescence Process of Optically Active Ions in Solids. *Science and Technology of Atomic, Molecular, Condensed Matter & Biological Systems*. Elsevier Science Publishing.
- Moses, W. (1999). Scintillator requirements for medical imaging. In *Proceedings of the 5th International Conference on Inorganic Scintillators and their Applications*. P. 11-21.
- Nakajima, H. & Mori, T. (2006). Photoluminescence excitation bands corresponding to defect states due to oxygen vacancies in yttria-stabilized zirconia. *Journal Alloys and Compounds*. Vol. 408-412, pp. 728-731.
- Nalwa, H.S. (2000). *Handbook of Nanostructured Materials and Nanotechnology*. Vol. 1-5, Academic, CA, San Diego.
- Nasar, R. S.; Cerqueira, M.; Longo, E.; Varela, J. A. (2004). Sintering mechanisms of  $\text{ZrO}_2:\text{MgO}$  with addition of  $\text{TiO}_2$  and  $\text{CuO}$ . *Ceramics International*. Vol. 30, No. 4, pp. 571-577.
- Noh, A.M.; Amin, Y.M.; Mahat, R.H.; Bradley, D.A. (2001). Investigation of some commercial TLD chips/discs as UV dosimeters. *Radiation Physics Chemistry*. Vol. 61, pp. 497-500.
- Petrik, N. G.; Taylor, D. P. & Orlando, T. M. (1999). Laser-stimulated luminescence of yttria-stabilized cubic zirconia crystals. *Journal Applied Physics*. Vol. 85, pp. 6770-6776.
- Rivera, T.; Roman, J.; Azorín, J.; Sosa, R. Guzmán, J.; Serrano\*, A.K.; García M. & Alarcón G. (2010a). Preparation of  $\text{CaSO}_4:\text{Dy}$  by precipitation method to gamma radiation dosimetry. *Applied Radiation and Isotopes*. Vol. 68, pp. 623-625.
- Rivera, T.; Sosa, T.; Azorín, J.; Zarate, J.; Ceja, A. (2010b). Synthesis and luminescent characterization of sol-gel derived zirconia-alumina. *Radiation Measurements*. Vol. 45, pp. 465-467.
- Rivera, T.; Azorin, J.; Barrera, M.; Soto, A.M. & Furetta, C. (2007a). Thermoluminescence (TL) of europium-doped  $\text{ZrO}_2$  obtained by sol-gel method. *Radiation Effects and Defects in Solids*. Vol. 162, No. 5, pp. 378-383.
- Rivera, T.; Olvera, L.; Martinez, A.; Molina, D.; Azorin, J.; Barrera, M.; Soto, A.M.; Sosa, R. & Furetta, C. (2007b). Thermoluminescence properties of copper doped zirconium oxide for UVR dosimetry. *Radiation Measurement*. Vol. 42, pp. 665-667

- Rivera, T.; Azorín, J.; Barrera, M.; Soto, A.M. (2007c). Nanostructural processing of advanced thermoluminescent materials. *Radiation Effects and Defects in Solids*. Vol. 162, No. 10-11, P. 731-736.
- Rivera, T.; Azorín, J.; Barrera, M.; Soto, A.M.; Sosa, R.; Furetta, C. (2007d). Structural characteristics of nanocrystalline ZrO<sub>2</sub> powder sol-gel derived to luminescent applications. *Radiation Effects and Defects in Solids*. Vol. 162, No. 7-8, pp. 597-603.
- Rivera, T.; Olvera, L.; Azorin, J.; Sosa, R.; Soto, A.M.; Barrera M. & Furetta, C. (2006). Preparation of luminescent nanocrystals started from amorphous zirconia prepared by sol-gel technique. *Radiation Effects and Defects in Solids*. Vol. 161, No. 2, pp. 91-100.
- Rivera, T.; Furetta, C.; Azorín, J. (2005a). Ultraviolet induced thermoluminescence in gadolinium-doped zirconium oxide films. *Materials Science Forum*. Vol. 480-481, pp.145-148.
- Rivera, T.; Olvera, L.; Azorín, J.; Soto, A.M.; Barrera, M. & Furetta, C. (2005b). Thermoluminescence (TL) characteristics of hydrogenated amorphous zirconia. *Radiation Effects and Defects in Solids*. Vol. 160, No. 5, pp. 181-186.
- Rivera, T.; Azorín, J.; Martínez, E. & García, M. (1999). Thermoluminescent and Optical Properties  $\alpha$ -Al<sub>2</sub>O<sub>3</sub>:C and ZrO<sub>2</sub>:Eu exposed to ultraviolet light. *Revista Mexicana de Fisica*. Vol.45, No.1, pp. 68-70.
- Rivera, T.; Azorín, J.; Martínez, E. & García, M. (1998). Termoluminiscencia inducida por la luz ultravioleta y visible en ZrO<sub>2</sub>:TR. *Revista Mexicana de Fisica*. Vol.44, No. 3 pp. 240-243.
- Roriz, V.M.; Rosa, A.L.; Peitl, O.; Zanatto, E.D.; Panzeri, H; De Oliveira, P.T. (2010). Efficacy of bioactive glass-ceramic (Biosilicate) in the maintenance of alveolar Ridges and in osseointegration of titanium implants. *Clinical Oral Implants Research*. Vol. 21, pp. 148-55
- Sahare, P.D.; Ranjan, R.; Salah, N.; Lochab, S.P. (2007). K<sub>3</sub>Na(SO<sub>4</sub>)<sub>2</sub>:Eu nanoparticles for high dose of ionizing Radiation. *Journal of Physics. D*. Vol. 40, pp.759-765.
- Salah, N.; Zishan H.K.; & Habib, S.S. (2011). Nanoparticles of Al<sub>2</sub>O<sub>3</sub>:Cr as a sensitive thermoluminescent material for high exposures of gamma rays irradiations. *Nuclear Instruments and Methods in Physics Research Section B: Beam Interactions with Materials and Atoms*. Vol. 269, No. 4, pp. 401-404.
- Salah, N.; Sahare, P.D.; Lochab, S.P.; Kumar, P. (2006a). TL and PL studies on CaSO<sub>4</sub>:Dy nanoparticles. *Radiation Measurements*. Vol. 41, pp. 40-47.
- Salah, N.; Sahare, P.D.; Rupasov, A.A. (2006b). Thermoluminescence of nanocrystalline LiF:Mg,Cu, P. *Journal of Luminescence*. Vol. 124, pp. 357-364.
- Sallé, C.; Ferey, F.; Grosseau, P.; Guilhot, B.; Iacconi, P.; Benabdesselam M. and Fantozzi, G. (2003). Detection of foreign phases in doped  $\alpha$ -alumina powders by Thermoluminescence. *Thermal Analysis and Calorimetry*. Vol. 73, No. 1, P. 25-33.
- Sasikumar, S. & Vijayaraghavan, R. (2010). Synthesis and Characterization of Bioceramic Calcium Phosphates by Rapid Combustion Synthesis. *Materials Science & Technology*. Vol. 26, No. 12, pp. 1114-1118.
- Shang, C.; Horng, L.; Ding, L.; Jow, H. (2009). Processing and physical properties of Al<sub>2</sub>O<sub>3</sub>/aluminum alloy composites. *Ceramics International*. Vol. 35, No. 1, pp. 7-12.

- Somiya, S.; Yamamoto, N.; Yanagina, H. (Eds.). (1988). *Advances in Ceramics*, vol. 24A, American Ceramic Society, Westerville, OH.
- Song, C. F.; Meng, K. L.; Ping, Y.; Feng, G.; Dong, X.; Duo, R.Y. (2002). A potential blue photoluminescence material: ZrO<sub>2</sub>-SiO<sub>2</sub> glasses. *Materials Science and Engineering B*. Vol. 94, No. 2-3, pp. 181-185.
- Studart, A. R.; Filser, F.; Kocher, P. & Gauckler, L.J. (2007). In vitro lifetime of dental ceramics under cycling loading in water. *Biomaterials*. Vol. 28, pp. 2695-2705.
- Suk, L.K. (2005). *Sintering, Densification, Grain, Growth & Microstructure*. ED. Elsevier, 2005.
- Taavoni, A.; Taheri, E.; Akhondi, H. (2009). The effect of zirconia content on properties of Al<sub>2</sub>O<sub>3</sub>-ZrO<sub>2</sub> (Y<sub>2</sub>O<sub>3</sub>) composite nanopowders synthesized by aqueous sol-gel method. *Journal of Non-Crystalline Solids*. Vol. 355, No. 4-5, pp. 311-316.
- Thompson, P.; Cox, D.E. & Hastings, J.B. (1987). Rietveld Refinement of Debye-Scherrer Synchrotron X-ray Data from Al<sub>2</sub>O<sub>3</sub>, *Journal Applied Crystallography*. Vol. 20, pp. 79-83.
- Van Dijken, A.; Meulenkamp, E. A.; Vanmaekelbergh, D. & Meijerink, A. (2000). The luminescence of nanocrystalline ZnO particles: the mechanism of the ultraviolet and visible emission. *Journal of Luminescence*. Vol. 87-89, pp. 454-456.
- Van Eijk, C.W.E. (1997). New scintillators, new light sensors, new applications. *Proceedings of the international conference on inorganic scintillators and their applications*. Shangai Branch Press, Shangai, China. pp. 3.
- Wang, Z.; Yang, B.; Fu, Z.; Dong, W.; Yang, Y. & Liu, W. (2005). UV-blue photoluminescence from ZrO<sub>2</sub> nanopowders prepared via glycine nitrate process. *Applied Physics A*. Vol. 81, pp. 691-694.
- Wilkinson, J.; Ucer, K.B. & Williams, R.T. (2004). Picosecond excitonic luminescence in ZnO and other wide-gap semiconductors. *Radiation Measurements*. Vol. 38, pp. 501-505.
- Yoshimura, M.; Sung, O.; Sando, M.; Niihara, K. (1999). Crystallization and microstructural characterization of ZrO<sub>2</sub> (3 mol% Y<sub>2</sub>O<sub>3</sub>) nano-sized powders with various Al<sub>2</sub>O<sub>3</sub> contents. *Journal of Alloys and Compounds*. Vol. 290, No. 1-2, pp. 284-289.
- Zárate, J.; Juárez, H.; Contreras, M.E. & Pérez, R. (2005). Experimental design and results from the preparation of precursory powders of ZrO<sub>2</sub>(3%Y<sub>2</sub>O<sub>3</sub>)/(10-95)% Al<sub>2</sub>O<sub>3</sub> composite. *Powder Technology*. Vol. 159, No. 3, pp. 135-141
- Zhang, H.; Fu, X.; Niu, S.; Sun, G. & Xin, Q. (2005). Synthesis and characterization of ZrO<sub>2</sub>:Eu nanopowder by EDTA complexing sol-gel method. *Materials Chemistry and Physics*. Vol. 91, No. 2-3, pp. 361-364.
- Zhang, J.; Zhang, Z.; Tang, Z.; Tao, Y.; Long, X. (2002). Luminescent Properties of the BaMgAl<sub>10</sub>O<sub>17</sub>:Eu<sup>2+</sup>,M<sup>3+</sup> (M = Nd, Er) Phosphor in the VUV Region. *Chemistry Materials*. Vol.14, pp. 3005-3008.
- Zhang, W. & Glasser, F.P. (1993). The structure and decomposition of Al<sub>2</sub>O<sub>3</sub>-ZrO<sub>2</sub> gels. *Journal European Ceramic Society*. Vol.11, pp.149-54.
- Zhang, Y.; Jin, S.; Yang, Y.; Chunsheng, Y. (2002). Annealing effects on the phase and microstructure transformations of nanocrystalline (ZrO<sub>2</sub>)<sub>1-x</sub>(Sc<sub>2</sub>O<sub>3</sub>)<sub>x</sub> (x=0.02-0.16) thin films deposited by sol-gel method. *Solid State Communications*. Vol. 122, No. 7-8, pp. 439-444.

Zhifa, S.; Chen, D.; Yu, Y.; Huang, P.; Lin, H. & Wang, Y. (2010). Luminescence in rare earth-doped transparent glass ceramics containing  $GdF_3$  nanocrystals for lighting applications. *Journal of Materials Science*. Vol. 45, No. 10, pp. 2775-2779

IntechOpen

IntechOpen

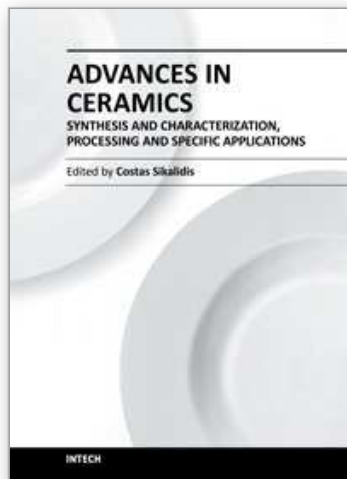

**Advances in Ceramics - Synthesis and Characterization,  
Processing and Specific Applications**

Edited by Prof. Costas Sikalidis

ISBN 978-953-307-505-1

Hard cover, 520 pages

**Publisher** InTech

**Published online** 09, August, 2011

**Published in print edition** August, 2011

The current book contains twenty-two chapters and is divided into three sections. Section I consists of nine chapters which discuss synthesis through innovative as well as modified conventional techniques of certain advanced ceramics (e.g. target materials, high strength porous ceramics, optical and thermo-luminescent ceramics, ceramic powders and fibers) and their characterization using a combination of well known and advanced techniques. Section II is also composed of nine chapters, which are dealing with the aqueous processing of nitride ceramics, the shape and size optimization of ceramic components through design methodologies and manufacturing technologies, the sinterability and properties of ZnNb oxide ceramics, the grinding optimization, the redox behaviour of ceria based and related materials, the alloy reinforcement by ceramic particles addition, the sintering study through dihedral surface angle using AFM and the surface modification and properties induced by a laser beam in pressings of ceramic powders. Section III includes four chapters which are dealing with the deposition of ceramic powders for oxide fuel cells preparation, the perovskite type ceramics for solid fuel cells, the ceramics for laser applications and fabrication and the characterization and modeling of protonic ceramics.

**How to reference**

In order to correctly reference this scholarly work, feel free to copy and paste the following:

Teodoro Rivera (2011). Synthesis and Thermoluminescent Characterization of Ceramics Materials, *Advances in Ceramics - Synthesis and Characterization, Processing and Specific Applications*, Prof. Costas Sikalidis (Ed.), ISBN: 978-953-307-505-1, InTech, Available from: <http://www.intechopen.com/books/advances-in-ceramics-synthesis-and-characterization-processing-and-specific-applications/synthesis-and-thermoluminescent-characterization-of-ceramics-materials>

**INTECH**  
open science | open minds

**InTech Europe**

University Campus STeP Ri  
Slavka Krautzeka 83/A  
51000 Rijeka, Croatia  
Phone: +385 (51) 770 447  
Fax: +385 (51) 686 166  
[www.intechopen.com](http://www.intechopen.com)

**InTech China**

Unit 405, Office Block, Hotel Equatorial Shanghai  
No.65, Yan An Road (West), Shanghai, 200040, China  
中国上海市延安西路65号上海国际贵都大饭店办公楼405单元  
Phone: +86-21-62489820  
Fax: +86-21-62489821



© 2011 The Author(s). Licensee IntechOpen. This chapter is distributed under the terms of the [Creative Commons Attribution-NonCommercial-ShareAlike-3.0 License](#), which permits use, distribution and reproduction for non-commercial purposes, provided the original is properly cited and derivative works building on this content are distributed under the same license.

IntechOpen

IntechOpen