

# We are IntechOpen, the world's leading publisher of Open Access books Built by scientists, for scientists

**4,800**

Open access books available

**122,000**

International authors and editors

**135M**

Downloads

Our authors are among the

**154**

Countries delivered to

**TOP 1%**

most cited scientists

**12.2%**

Contributors from top 500 universities



**WEB OF SCIENCE™**

Selection of our books indexed in the Book Citation Index  
in Web of Science™ Core Collection (BKCI)

Interested in publishing with us?  
Contact [book.department@intechopen.com](mailto:book.department@intechopen.com)

Numbers displayed above are based on latest data collected.

For more information visit [www.intechopen.com](http://www.intechopen.com)



# Biomass Waste as a Renewable Source of Biogas Production-Experiments

Adrian Eugen Cioablă and Ioana Ionel  
*University "Politehnica" from Timisoara  
 Romania*

## 1. Introduction

Global supply of energy is facing several increasing challenges. Energy consumption is on a moderate increase, especially in rapidly developing countries. The overall size of the world energy market nearly doubled between 1971 and 2003, driven by rapid expansion of energy usage in the developing world, where population and energy activity have grown.

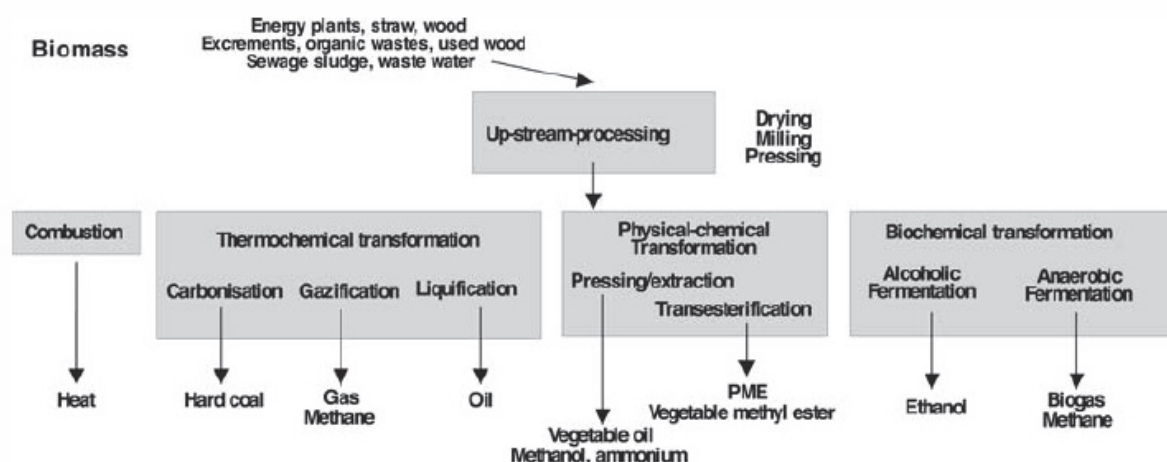

Fig. 1. Applied technologies for transforming biomass in secondary energy sources (Deublein & Steinhauser, 2008)

The International Energy Agency (IEA) has projected an increase in primary energy demand of 1.6 per cent per year until 2030, when the cumulative increase will be equal to half of current demand. At present, fossil fuels - oil, coal, and natural gas - dominate the world energy economy, providing 80 per cent of the world's primary energy supply of 449 EJ/year (Heinimo, 2008).

In Figure 1 the applied technologies for transforming biomass in secondary sources of energy were presented.

The use of biomass has, for millennia, helped human society to fulfill many of its fundamental energy needs, such as for the production of goods, cooking, domestic heating and the transport of people and goods (Petersen, 2008). One of the technologies used for recovering the energy from different types of biomass residues is anaerobic fermentation that has as a primary result the production of biogas.

Anaerobic digestion of energy crops, residues, and wastes is of increasing interest in order to reduce the greenhouse gas emissions and to facilitate a sustainable development of energy supply. Production of biogas provides a versatile carrier of renewable energy, as methane can be used for replacement of fossil fuels in both heat and power generation and as a vehicle fuel (Weiland, 2009).

Organic waste, as a main constituent of solid biomass, has a high potential for biogas generation but the uncontrolled decomposition of waste from agricultural and agro-industrial sources results in large-scale contamination of land, water, and air. All of these cause potentially severe pollution problems and are subject to rigorous environmental regulation in most countries (Busch et al., 2008; Hansen & Cheong, 2007).

Romania, through member countries of the European Union, tries to correlate its activities in the field of green energy production, and different steps are taken in order to accomplish this fact.

According with the Romanian Statistical Register from 2007, the existing agricultural surface decreased reported to the year 2001 from 14852,3 ha to 14731 ha in 2006, while the forest surface increased from 6605,7 ha to 6754,7 ha in 2006.

Related with the European Union's project to achieve an average share of electricity from renewable energy sources of 12% by the year 2010, biomass is expected to provide about 10% of the whole European energy supply, which is equivalent to about 5800 PJ (1 PJ = 1 petajoule =  $10^{15}$  J).

In 2030 it is probable that biomass will be an outstanding solution for individual heating, dominated by pellets in urban areas and by wood chips, wood logs and pellets in rural areas. The boilers and stoves markets will progressively shift from oil based system to biomass based system. Heating oil will progressively disappear because of unaffordable prices. Micro co-generation of heat and power based on biomass will be progressively available in all sizes even at household level and for nearly all part load cases. Most district heating and cooling system will be retrofitted to solar thermal, biomass and geothermal and many new small heats cool and biogas networks will appear (Ionel & Cioabla, 2010).

Related with the existing literature, the field of biogas production and applications is developed at a large scale, the existing studies covering different characteristics of this domain. In connection with the process characteristics, Wu et. al (2009) presented an extensive study related with the pH effect on anaerobic fermentation on sludge material, Li et. al (2011) conducted a review over the solid state anaerobic digestion from organic waste in accordance with methane production, while Busch et. al (2009) presented a new technology for biogas production from solid waste and biomass through means of a double-stage solid-liquid biogas process. Studies were conducted also in the field of biogas production enhancement from solid substrates under different technologies (Yadvika et. al, 2004, Amon et. al, 2007, Karellas et. al, 2010) and in regard to designs of the anaerobic digesters there can be mentioned the contributions of Igoni et. al (2008) or Walla & Schneeberger (2008) in regards to the optimum size of the biogas plants or anaerobic digesters designs for biogas production

## **2. General presentation of different materials used during the anaerobic fermentation process**

One of the directions involved in the research activities regarding biogas production was the usage of different vegetal substrates, having in mind the potential of vegetal biomass in the present context.

In literature there are presented different aspects related with

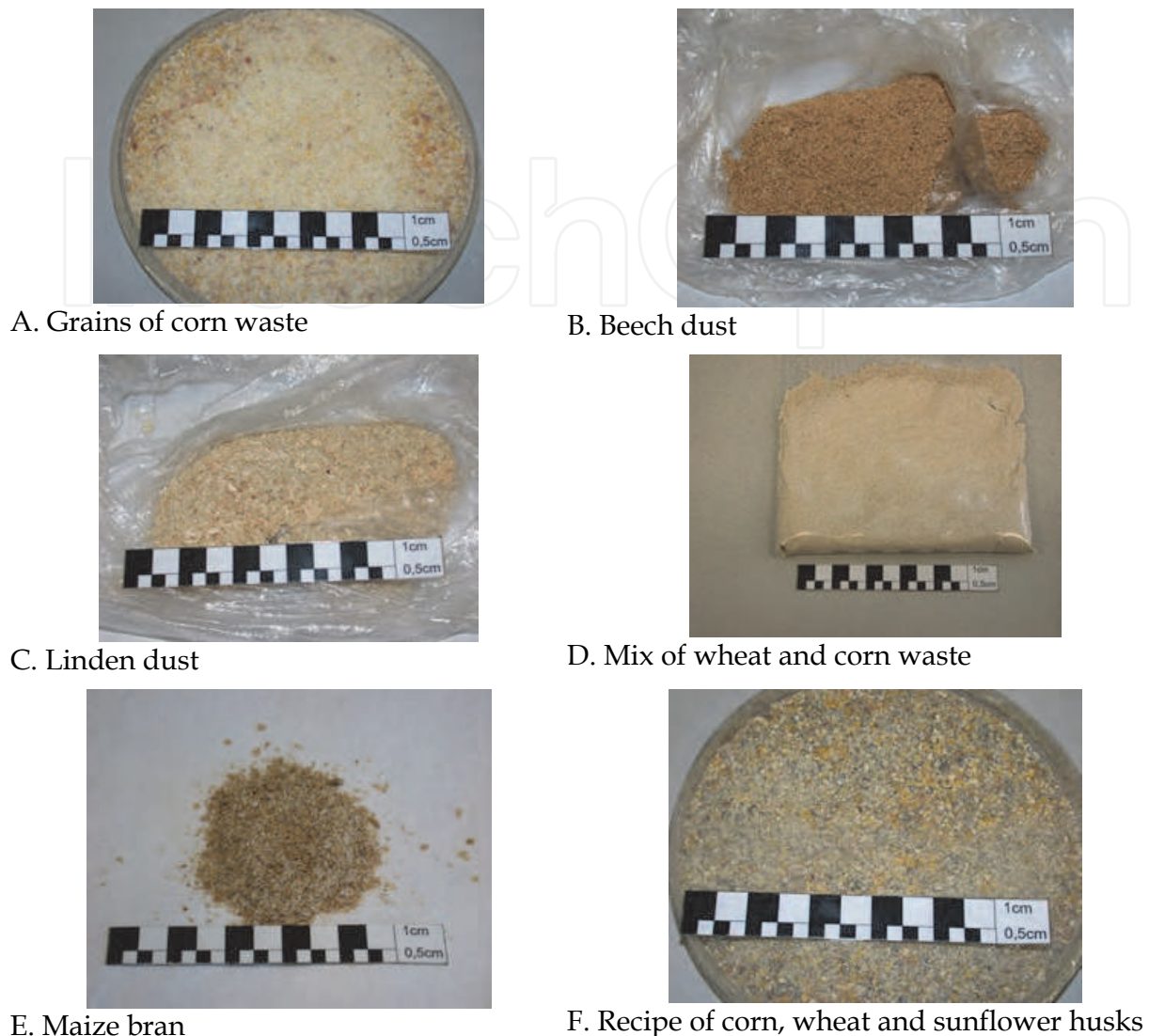

Fig. 2. Materials used in anaerobe fermentation (Cioablă, 2009)

In figures 2.A up to 2.F are presented different sorts of material used in anaerobe fermentation processes.

As it can be seen from the images, the materials that were studied are: beech dust, linden dust, corn waste, mix of wheat and corn waste, degraded maize bran and a recipe of wheat, corn and sunflower husks.

In Table 1 some of the general characteristics of the used materials are presented.

In Table 2 are presented the major elements presented in the analyzed sorts of biomass.

In Table 3 are underlined the minor elements presented in the analyzed biomass.

Related to the study of different substrates of material used to obtain biogas, researches over the influence of municipal wastes in the context of biogas production were conducted.

In figure 3 is presented a general image of municipal residues used in order to produce biogas. Due to the combined approach of obtaining biogas of different qualities and in various quantities using different sorts of material, the next paragraph is dedicated to the pilot installations built with the goal of obtaining good results in this field of interest.

No	Sample	Total Humidity [%]	Hygroscopic Humidity [%]	Ash content [%]	High calorific value [kJ/kg]	Low calorific value [kJ/kg]
1	Maize bran	10.23	0.16	4,63	17098	15535
2	Recipe of wheat, maize and sunflower husks	11.76	1.04	1,81	16744	15192
3	Grains of corn waste	13.91	1.50	1,88	15933	14488
4	Beech dust	6.43	0.51	0,92	17751	16322
5	Linden dust	8.01	0.23	0,54	17705	16263
6	Mix of wheat and corn waste	10.98	0.88	1,64	16591	15245

Table 1. General characteristics of the biomass sorts (Cioablă, 2009)

No	Elem.	Maize bran [mg/kg]	Cereal recipe [mg/kg]	Grains of corn waste [mg/kg]	Beech dust [mg/kg]	Linden dust [mg/kg]	Mix of wheat and corn waste [mg/kg]
1	Mg	1331	764	733	496	289	797
2	Al	71	61	62	143	85	55
3	Si	174	34	26	321	183	-
4	P	5855	2419	1725	267	82	2332
5	S	1165	925	736	109	82	1181
6	Cl	370	388	375	47	44	680
7	K	9697	4359	2955	2035	936	4491
8	Ca	1209	901	382	3605	2808	716
9	Mn	108	14	3	74	34	31
10	Fe	177	117	84	122	77	81
11	Zn	69	25	16	9	7	23

Table 2. Major elements in the composition of analyzed biomass (Cioablă, 2009)

No	Elem.	Maize bran [mg/kg]	Cereal recipe [mg/kg]	Grains of corn waste [mg/kg]	Beech dust [mg/kg]	Linden dust [mg/kg]	Mix of wheat and corn waste [mg/kg]
1	Cr	0.919	8.034	2.225	1.868	3315	0.705
2	Mn	184.127	27.236	10.562	116.715	56.62	59.158
3	Co	1.385	0.866	1.763	1231	1.172	0.6
4	Ni	1.494	4.789	0.776	157	2.138	-
5	Cu	6.053	-	-	-	-	-
6	As	0.366	-	-	2.081	-	-
7	Se	0.833	-	0.18	1.004	0.002	0.289
8	Br	5.472	10.836	11.5	2366	1.632	10.114
9	Sr	7.256	2.819	0.662	12.579	11.824	2.098
10	Cd	4.102	3.905	3.52	3.604	2.457	3.58
11	Sn	-	0.387	0.653	-	-	0.584
12	Hg	-	-	-	-	-	-
13	Pb	6318	8.02	7.737	15.704	7.899	8.291

Table 3. Minor elements in the composition of analyzed biomass (Cioablă, 2009)



Fig. 3. Municipal residues

### 3. Pilot installations: Role and results

#### 3.1 Small scale installation for the degradation study during the anaerobic fermentation process

The first installation which will be presented is a laboratory scale installation used for the experimental study of the biomass behavior regarding the degradation process during the anaerobic fermentation. In Figure 4 is presented the general schematics of the installation.

As it can be seen in Figure 4, the anaerobic fermentation reactors are made from thermal resistant glass, which is also pressure resistant until 0.5 – 0.6 bar, with a useful volume of about 2 l. In order to guarantee that the gas is properly washed, the reactors are connected to smaller thermal resistant glass vessels filled with 200 ml of water. The formed biogas inside the anaerobic fermentation reactors will pass inside the small glass vessels and will be

washed of the impurities. The process can be inhibited because of the lack of homogenization inside the reactors and because of this the system is equipped with magnets positioned in the lower part of the reactors in order to have a magnetic agitation during the process. The agitation process is made on a daily basis.

Also the heating system is realized with the help of a thermocouple and a temperature controller in order to assure the necessary temperatures during the process. The chosen temperature regime is the mesophilic one (30 – 37 °C).

After passing through the small reactors filled with water, the biogas will be kept inside small gas bags with the potential of analyzing it after the process.



Fig. 4. Components of the small scale installation (Cioablă, 2009)

### 3.2 Pilot installation for obtaining biomass from vegetal biomass

In order to study at a bigger scale the process of anaerobic fermentation with all its particularities, a pilot installation was built at the Unconventional Energies Laboratory from the Mechanical Engineering Faculty, “Politehnica” University from Timisoara. Its main role was the experimental approach of biogas production from vegetal biomass.

In Figure 5 the general schematics of the pilot installation is presented.

From the biomass deposit, the used material is passed through a mill, and then it's sent to the tank where the preparation of the suspension of biomass is made (1). The biomass suspension is transported with the help of the pump (2) and introduced into the fermentation reactors (3). The correction agent tank for the pH assures, through the control system, the conditions for the process of anaerobic fermentation. The resulted biogas is passed through a filter for retaining the H<sub>2</sub>S (5) and after that, through a system used for retaining CO<sub>2</sub> (6), after which takes place the CO<sub>2</sub> desorption and the compression of the CO<sub>2</sub> in the adjacent system (7) and the purified biogas is sent to use (8). The used material is discharged through the means of a gravimetric system (9), and the solid material is retained for being dried using the natural drying. After that it is sent to a compost deposit for being used as a soil fertilizer. When the case, a part of the resulting liquid is neutralized, in the system (10) and sent to the sewerage network, or is transported by the recirculation pump (2) from the suspension preparation tank (1). The fermentation reactors are thermostat heated with the system (11). For the homogenization of the suspension a bubbling system (12) is used, made by polypropylene pipes to avoid the possible corrosion. Also, for depositing small quantities of biogas of the purpose of analyzing, the installation is equipped with a small tank (13) positioned at the top of the reservoirs.

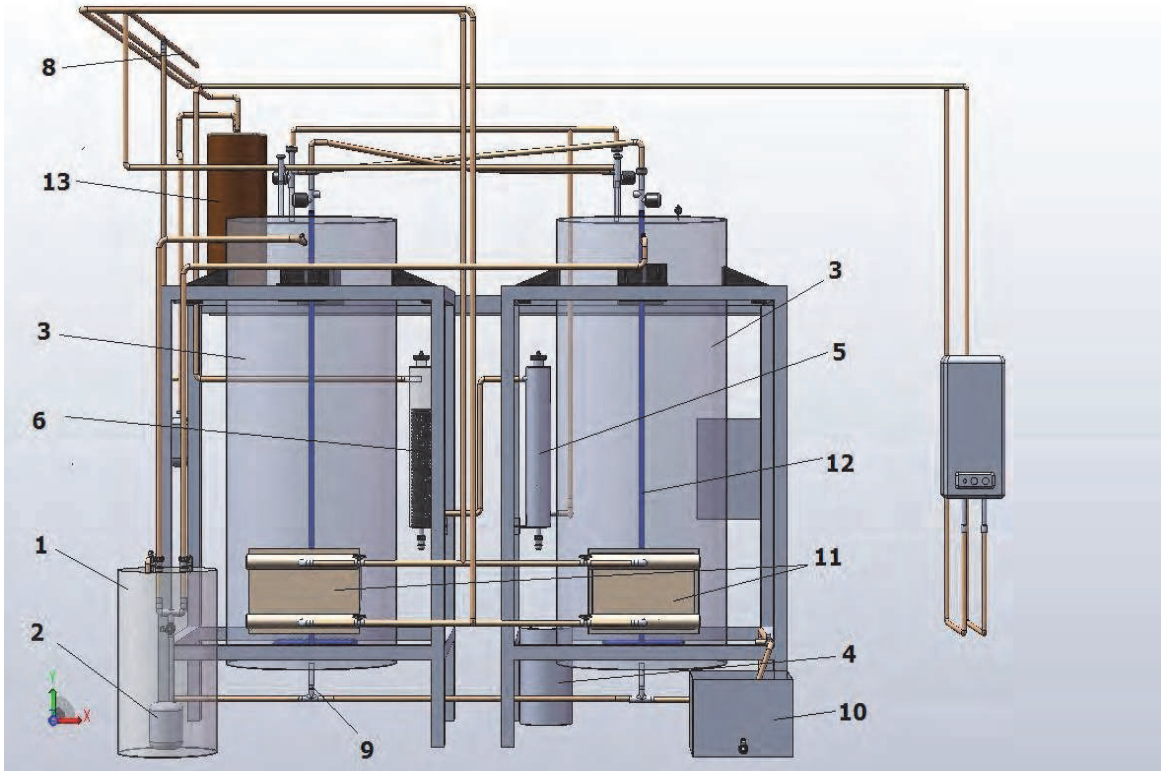

Fig. 5. Principle scheme for the pilot installation used for obtaining biogas from biomass (Cioablă, 2009)

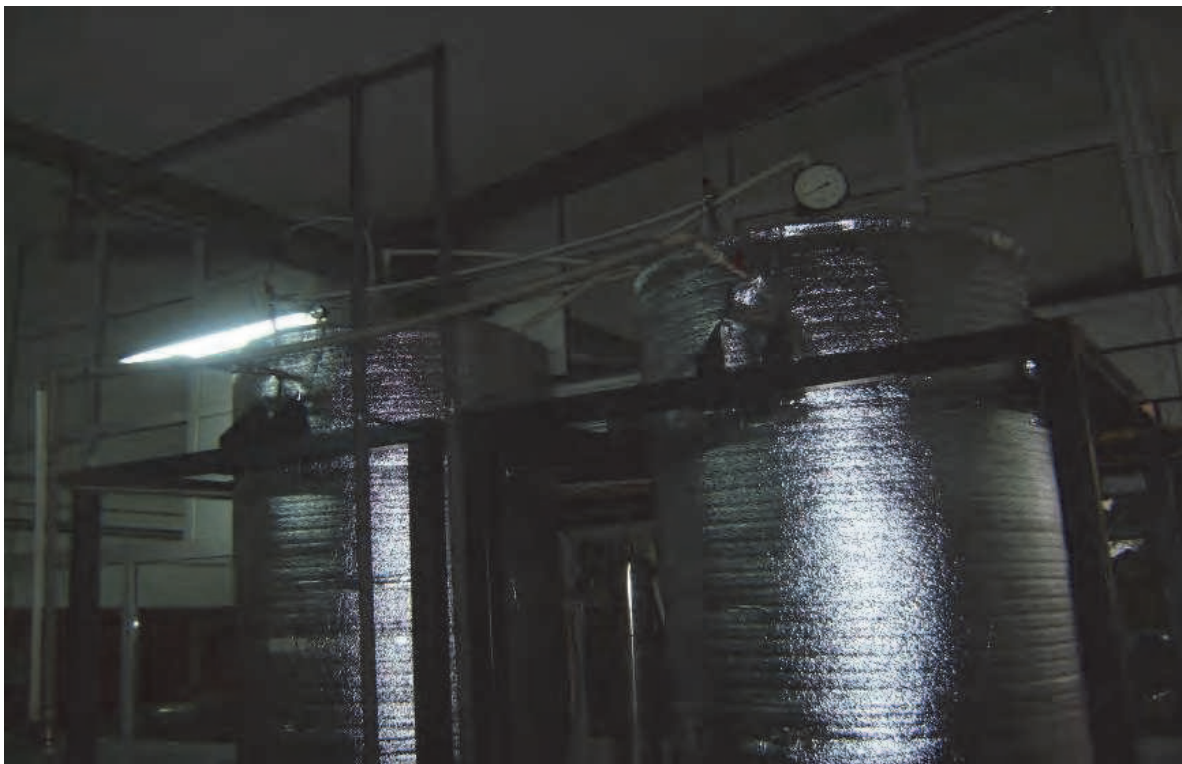

Fig. 6. Front view of the pilot installation (Cioablă, 2009)



From Figure 6 it can be observed the front view of the pilot installation. In figure 7 is presented the principle scheme for the CO<sub>2</sub> retaining system.

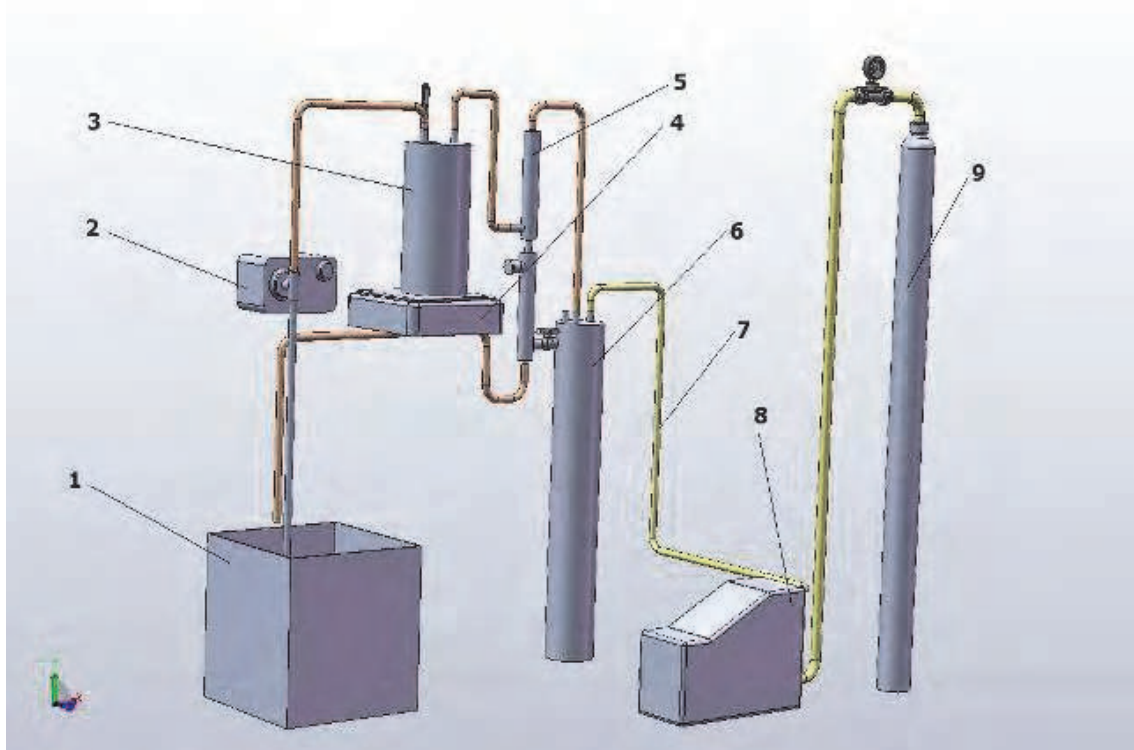

Fig. 7. Principle scheme for the CO<sub>2</sub> retaining system (Cioablă, 2009)

The system is composed from a tank (1) from which the water is passed by the means of a dosing pump (2) - similar with the dosing pumps used for the pH correction -, a stainless steel tank (3) positioned on an heating device (4), a liquid separator (5) and a buffer tank (6) from which the gas is aspirated with the help of a Haug compressor and inserted in a cylinder at a pressure of about 10 - 26 bar. The temperature inside the stainless steel tank can reach values of 50 - 60 °C.

### 3.3 Pilot installation for obtaining biogas from municipal residues

Relative to the experimental studies involving different substrates used for biogas production, a pilot installation was also built inside an industrial platform, in order to study the potential of Timisoara municipal residues concerning the quality and quantity of biogas. In Figure 8 it is presented a general view of the pilot installation.

Figure 9 it is presents the general description of the pilot installation.

The biodegradable residues are introduced inside the anaerobic fermentation tank, having in mind that the process parameters (temperature, pressure, pH) are monitored in real time. The used temperature regime is the mesophilic one. The pH is modified when necessary with a lime based suspension in order to bring it to the necessary values.

The produced biogas is passed through a H<sub>2</sub>S retaining system and also a CO<sub>2</sub> retaining system into a storage tank. The composition of the produced biogas is determined before and after the retention systems with the help of gas analyzers. The next step is to test the produced biogas in combustion processes in order to establish the applicability to different users.



Fig. 8. Front view of the pilot installation

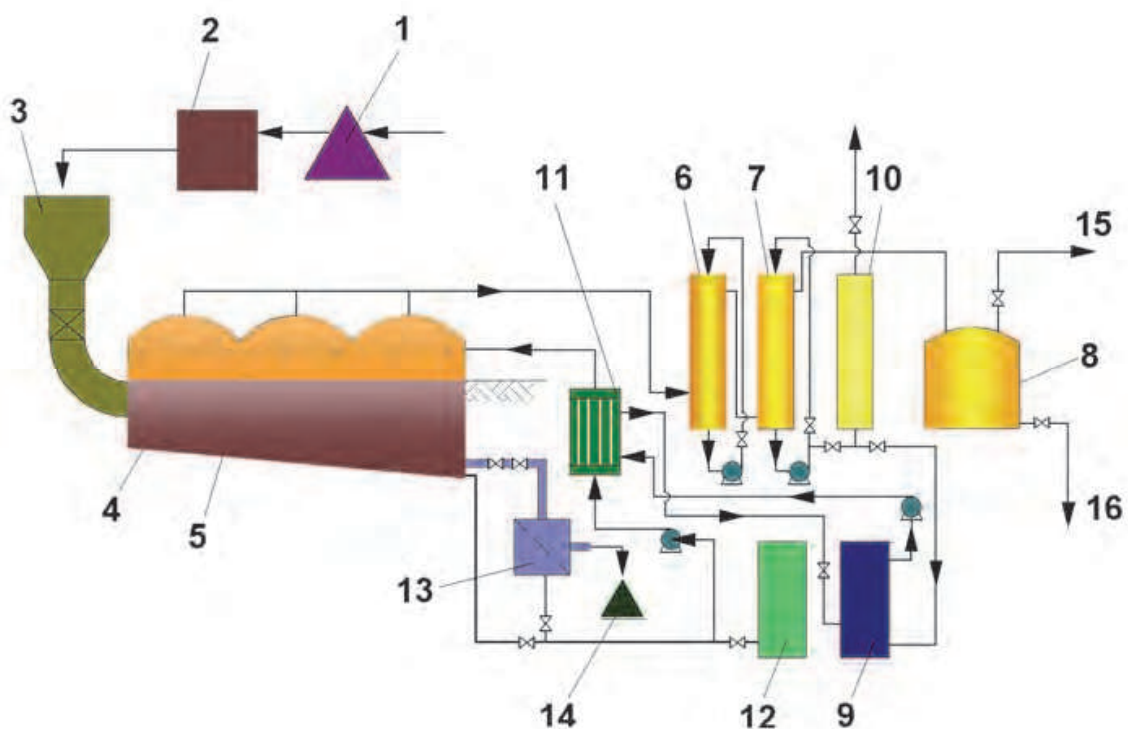

1 - Biodegradable municipal landfill 2 - Grinding waste system 3 - Waste feeding system 4 - Anaerobic fermentation tank 5 - Nozzles equipped system for pH correction 6 - Filter for retaining H<sub>2</sub>S from biogas 7 - Filter for retaining CO<sub>2</sub> from biogas 8 - Biogas storage tank 9 - CO<sub>2</sub> desorption tank 10 - CO<sub>2</sub> cooling tank 11 - Heat exchanger 12 - pH correction tank 13 - Filter for fermented residue 14 - Storage for solid residue 15 - Biogas user connection 16 - Condensate removal valve

Fig. 9. General presentation of the pilot installation:

One of the particulate aspects regarding this pilot is the fact that the invention was awarded with the gold medal at the International Exposition IENA 2010, in Nürnberg, Germany and also the gold medal at the "Inventika" Exposition in Bucharest, Romania, 2010.

The principle used has common points with the second pilot installation, which was already presented, but the constructive solution is different and adapted to a much larger scale.

### 3.4 Results on the pilot installations

This paragraph will underline some of the main results obtained on the presented installations in order to highlight the potential of obtaining biogas from different sorts of material.

#### 3.4.1 Results obtained on the small scale installation

The temperature variation during the anaerobic fermentation process and the degraded aspect of the material at the end of the process will be underlined. The degradation appearance is observed thanks to images taken with the help of a binocular magnifier.

In Figure 10 is presented the temperature variation during the anaerobic fermentation. It can be observed that the average value is around 36°C (mesophilic regime).

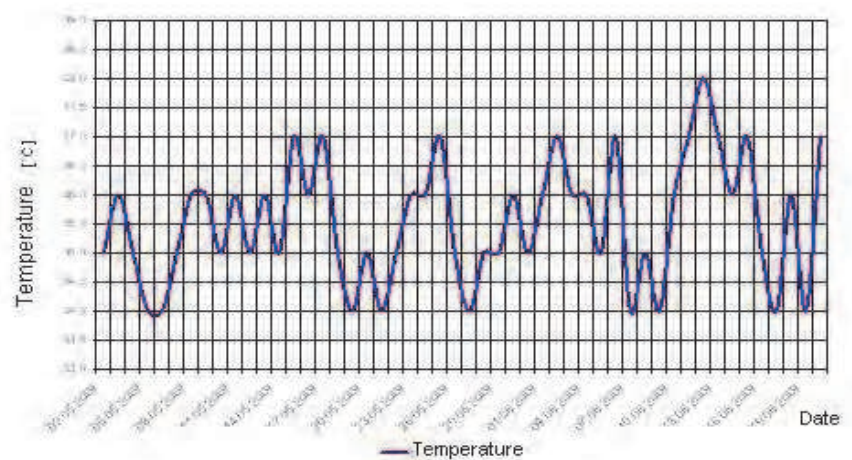

Fig. 10. Temperature variation during anaerobic fermentation (Cioablă, 2009)

From Figure 10 it is underlined the fact that the temperature variation in time is fluctuating in the range of 34 °C - 37 °C, the incorporated system for the temperature control allowing peaks of maximum 37 °C and minimum 34 °C. This temperature domain will have as a main result a biogas production in time starting after a period of 15 - 20 days, during a period of time necessary for the process to develop, taking into consideration the fact that no inoculums were used for process acceleration.

In Figures 11 and 12 it can be seen the general structure for the cereal mix and the bran with the help of a binocular magnifier. This is a step taken in regard to studying the general aspect of the material during anaerobic fermentation from the point of view of the degradation process. It can be observed the fibrous structure of the bran and also it can be partially observed the bacterial halo inside the suspension. Also, there are signs of degradation related to the general aspect (the lack of color and surrounding bacteria formations on the material surface). Even if this part has a rather imagistic orientation related to the degradation process, the intention was to underline in a certain measure the rather selective behavior of bacteria during the process in regard to the different used substrates.

The second part of this paragraph highlights parts of the obtained results on the pilot installation used in order to obtain biogas from the vegetal biomass. The temperature and

the pH variation from the two reservoirs and production of biogas will be presented for the analyzed batches.



Fig. 11. Detail for the mix (Cioablă, 2009)

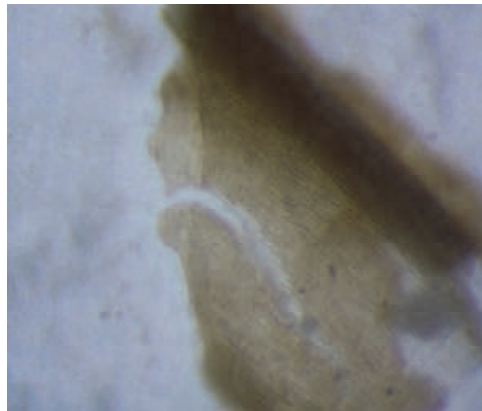

Fig. 12. Structure of the bran (Cioablă, 2009)

### 3.4.2 Results obtained on the pilot installation

There were made different studies in order to determine the general behavior of substrates with different potentials related to the anaerobic fermentation. This paragraph will underline the trials made on four substrates, from which two are wood residues and two are degraded cereal materials.

The monitored parameters which are presented for all the batches are temperature and pH taking into consideration the fact that the temperature regime chosen for all the batches was the mesophilic one (30 °C - 37 °C).

#### 3.4.2.1 Beech dust batch

$$C/N \text{ ratio} = \frac{47.9}{0.22} = 217 \quad (1)$$

Quantity of solid material introduced in each reservoir = 75 kg

Solid material / liquid volume ratio = 0.037 %

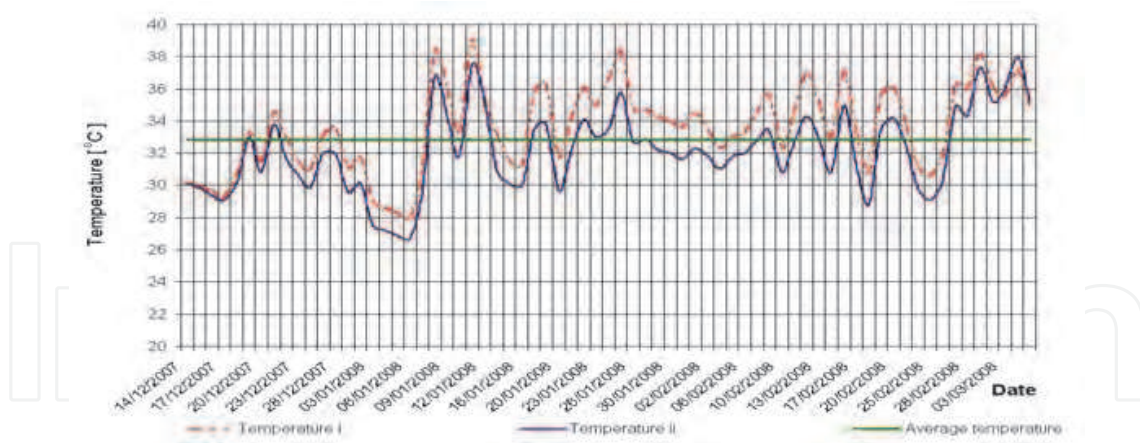

Fig. 13. Temperature variation (Cioablă, 2009)

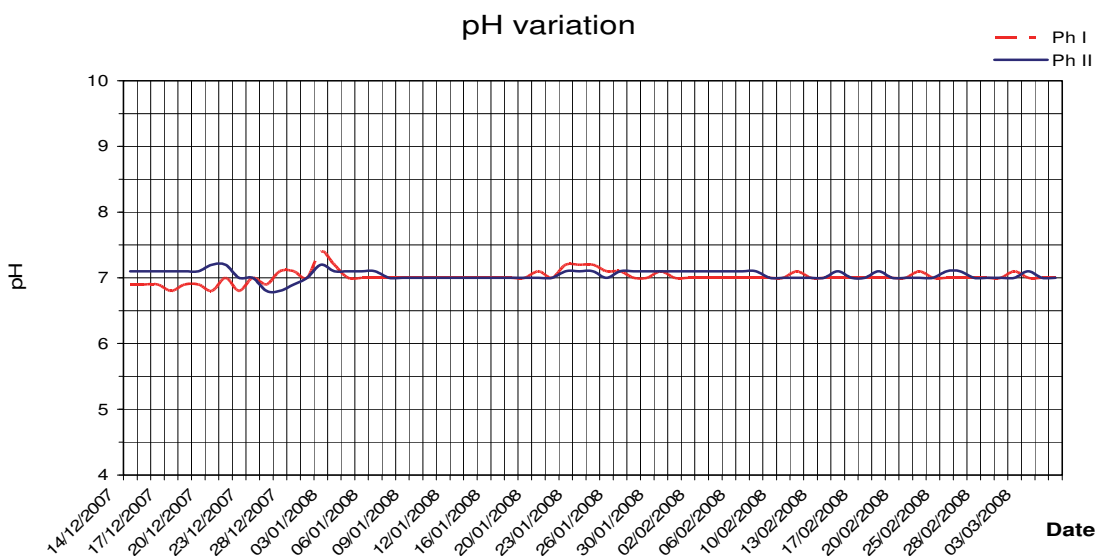

Fig. 14. pH variation (Cioablă, 2009)

From Figures 13 and 14 it can be observed that there is a difference between the variations of temperature for the two reservoirs, inside the established temperature domain, even if the graphic shape is about identical for both reservoirs. The possible explanation of this difference can be related to the general distribution of the material inside the anaerobic fermentation tanks and to the heat transfer inside the tanks as a result of the contact between the heat exchangers and the suspension, even if the general conditions of the process were the same.

The pH values were 6.5 – 7.5, the small differences from one day to another being corrected with the help of the dosing pumps.

The produced biogas quantity was under  $0.05 \text{ m}^3 / \text{day}$ , making this substrate unfit for this type of capitalization. Also the residual material obtained after the process presented small signs of degradation, mainly because of its high lingo - cellulosed content. Even if before the process, the material was subjected to a preliminary acid hydrolysis, using a suspension of water and acetic acid (pH = 3.5) at approximately  $55 - 60 \text{ }^\circ\text{C}$  and normal pressure, this step was not enough for breaking the cellulose chains inside it.

3.4.2.2 Linden dust batch

$$C / N \text{ ratio} = \frac{47.5}{0.42} = 113 \tag{2}$$

Quantity of solid material introduced in each reservoir = 75 kg

Solid material / liquid volume ratio = 0.037 %

The measurements and the monitoring process are taken in similar condition as the first batch. Because the material had also a high content of lingo - cellulose (wood residue), there were taken the same steps preliminary to using the material inside the anaerobic fermentation tanks. Having in mind the conditions related to the temperature which was also determined for the first batch, the pH variation suggests that in the first period of time the general tendency was for the acid domain. In those conditions it was necessary to correct the initial values in order to bring them close to neutral and more suited domain for the anaerobic process to take place.

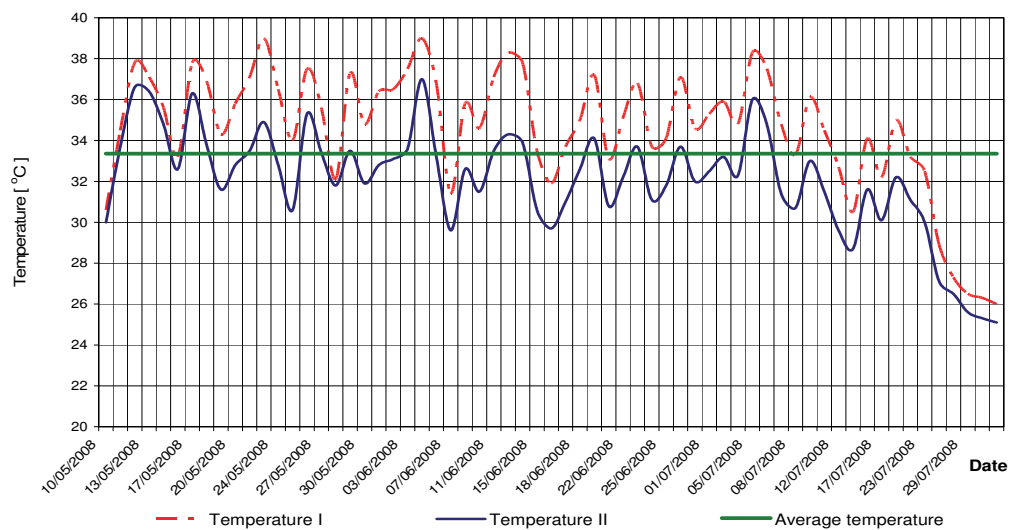

Fig. 15. Temperature variation (Cioabla, 2009)

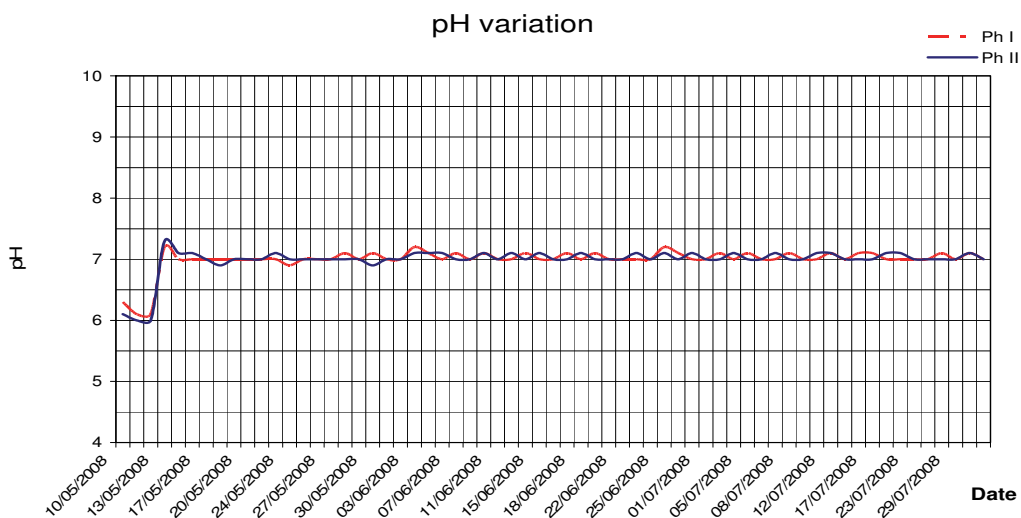

Fig. 16. pH variation (Cioabla, 2009)

The biogas production was also under 0.05 m<sup>3</sup>/ day, and the substrate proved to be unfit for this type of capitalization. Like for the first batch, the residual material obtained after the process presented small signs of degradation.

### 3.4.2.3 Mix of wheat and corn waste

Because the fact that the first studies on wood residues proved to have negative results, next studies were made on agricultural residues in order to determine their potential related with biogas production.

The next batch had in it's composition a mixture of 50% grains of degraded corn and 50 % grains of degraded wheat. The quantity of solid material introduced in each reservoir was about 75 kg.

C / N ration having in mind that in our case there is a mixture of two different types of biomass is calculated with the formula:

$$\frac{C}{N} = \frac{P_1 r_1 + P_2 r_2}{P_1 + P_2} \quad (3)$$

where:

$P_1, P_2$  - the material quantities introduced in the reservoirs

$r_1, r_2$  - C / N ration for each type of material

$P_1 = P_{\text{corn cobs}} = 37.5 \text{ kg}$

$P_2 = P_{\text{wheat}} = 37.5 \text{ kg}$

$$r_1 = r_{\text{corn cobs}} = \frac{46.58}{0.47} = 99.1$$

$$r_2 = r_{\text{wheat}} = \frac{43.6}{2.28} = 19.1$$

C / N ration for the mix is:

$$C / N = \frac{37.5 \times 99.1 + 37.5 \times 19.1}{37.5 + 37.5} = 59.1$$

The graphics below present the variation of temperature, ph, pressure difference and biogas production, determined in the same conditions like for the first two batches.

From the Figure 17 it can be observed that the average value for the temperature is under 32°C, and the difference between the temperatures of the two reservoirs is about the same as for the first two batches.

The pH variation, presented in Figure 18 shows that the average value is about 7, and this neutral value is, like for the other batches, important because it will not affect the process of anaerobic fermentation.

Even if the pH average value is around 7, in the first period of time (approximately 15 days) the material had an acid pH, characteristic the first stage of the process (acidogenesis). With the help of the dosing pumps, the pH value was corrected and the neutral value was obtained for the rest of the period during the anaerobic fermentation process.

The average value for biogas production was 0.25 m<sup>3</sup> / day, which represented a step forward related with the obtained values from the first two batches.

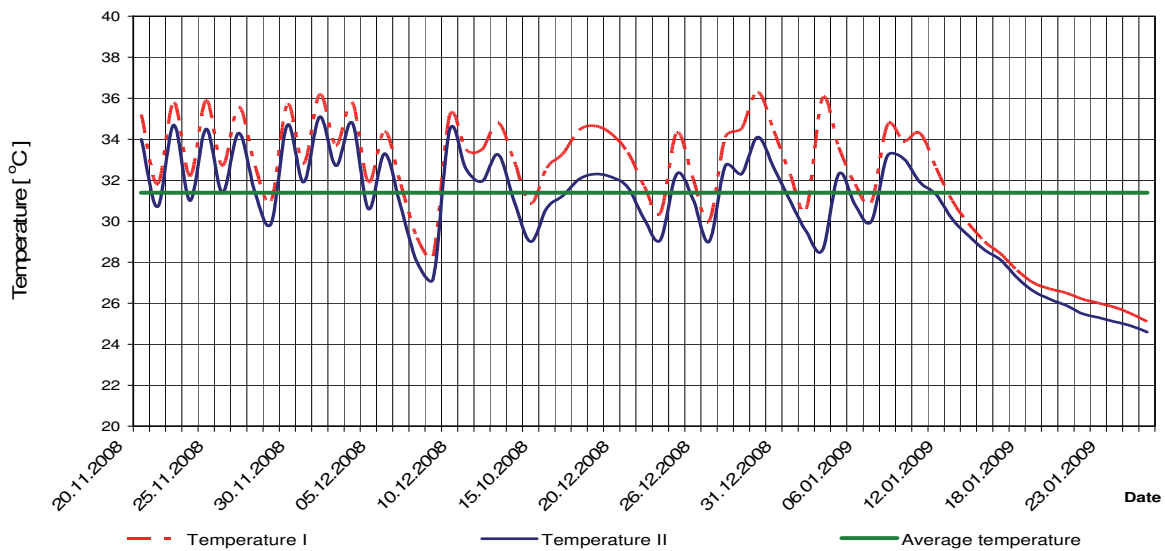

Fig. 17. Temperature variation (Cioablă, 2009)

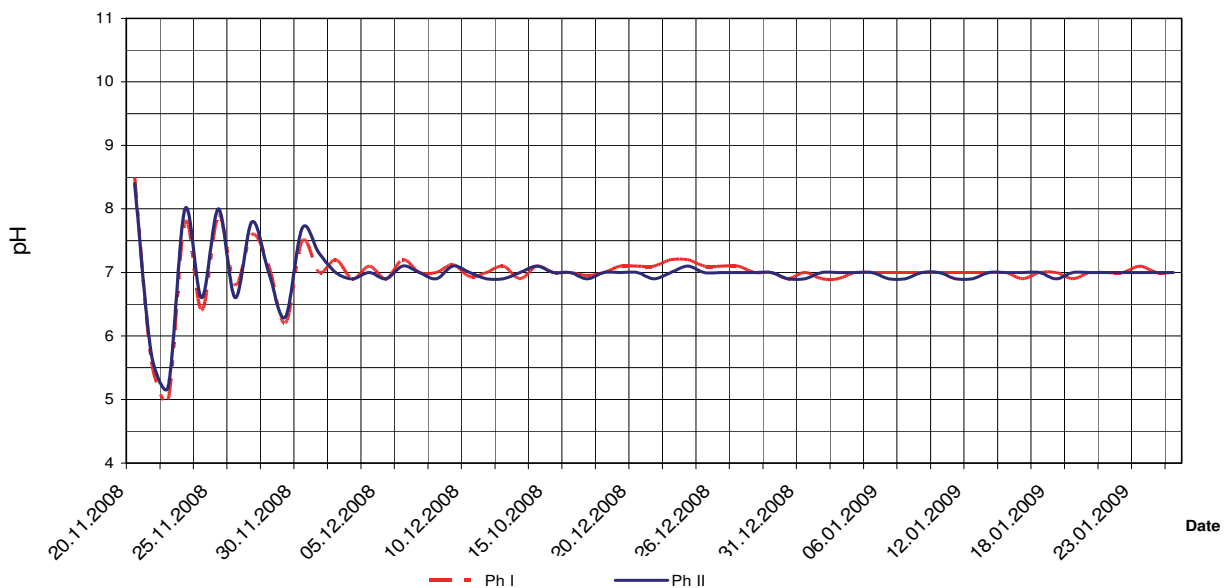

Fig. 18. pH variation (Cioablă, 2009)

#### 3.4.2.4 Corn waste batch

The fourth batch was composed only from corn waste; the total quantity of solid material introduced in each reservoir was 75 kg.

The solid material / liquid volume ratio = 0.037 %

$$C / N \text{ ratio} = \frac{46.58}{0.47} = 99.1 \quad (4)$$

Next graphics present the variation of the main parameters like for the first three batches.



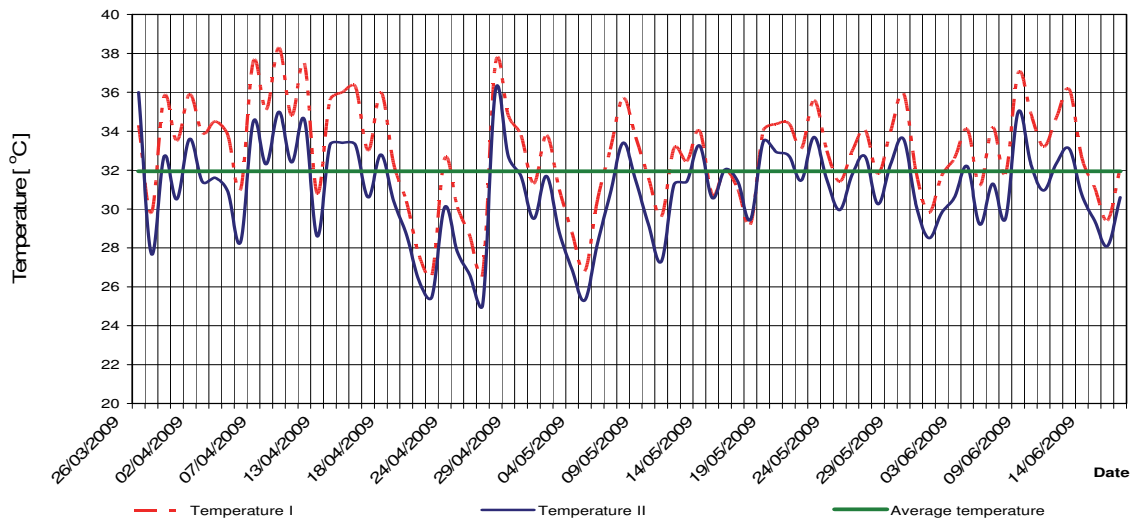

Fig. 19. Temperature variation (Cioablă, 2009)

From Figure 19 it can be observed the same variation between temperatures inside the reservoirs that was noticed for the other batches, and the average value is about 32° C, making it clear that the potential reason of this difference between the reservoirs is connected with the heat transfer between the heat exchanger and the material suspension for each tank..

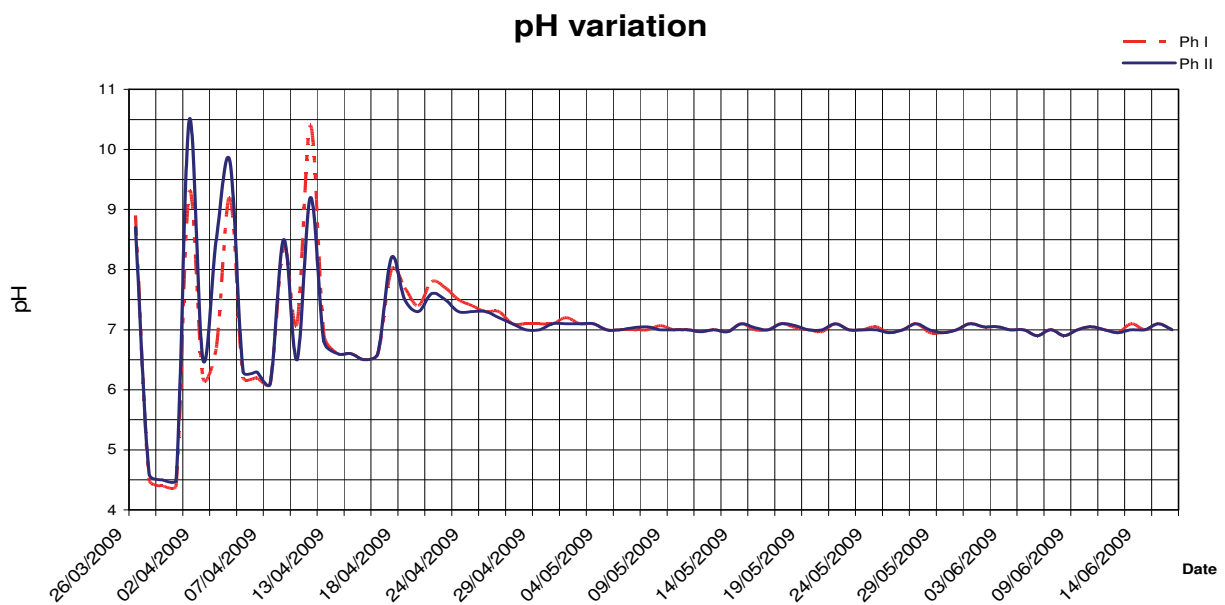

Fig. 20. pH variation (Cioablă, 2009)

The pH values in figure 20 are fluctuating very much in the first part of the process, suggesting that the suspension of material needed to be corrected each day in the first period with the help of dosing pumps. The correction was made to a maximum of 10 during 1 - 2 days, because the decrease in pH until the next day was of 2 - 3 units.

The period of time necessary to bring the pH value to a neutral level was about 25 days, this batch being the hardest to control from this point of view.

Related to the biogas production, this batch had the best results, with an average value of over  $0.25 \text{ m}^3 / \text{day}$ .

### 3.4.3 Results obtained using municipal residues as substrate

The last part of this paragraph underlines some of the results obtained on the third pilot installation, using municipal residues as substrate.

The measurements were made during a period of 73 days and during this time there were observed and adjusted the pH and temperature for the batch.

In the next figures are presented the variations for the temperature and pH during the batch of material.

The main difference between the two pilot installations is that for the last one presented, the variation for the main parameters is made just for one reservoir, the second one having the buffer role inside the installation.

Also, because the used material is a mix of organic and inorganic residues it is difficult to establish the exact composition of the batch.

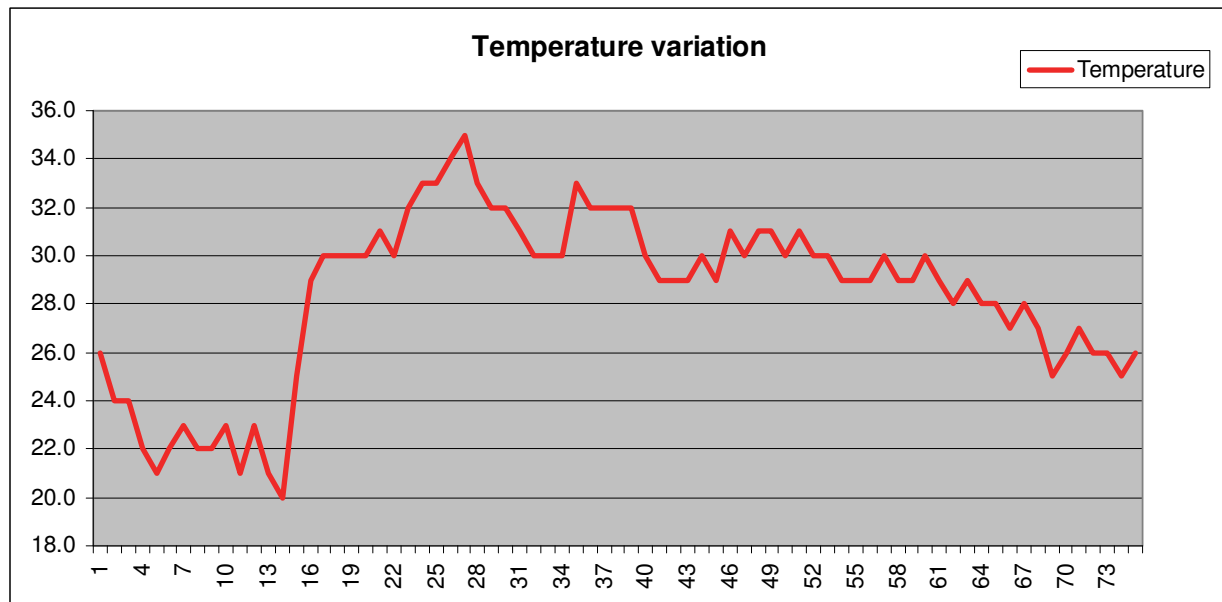

Fig. 21. Temperature variation

The temperature shows a two - domain regime (cryophilic and mesophilic) with variations between  $20 \text{ }^\circ\text{C}$  and  $35 \text{ }^\circ\text{C}$ , meaning a relatively different behavior according to the suspension used in the batch. Because in the first period of time the temperature value was low, the process inside the fermentation tank was developed with a relatively low speed, the production of biogas starting approximately after 25 - 30 days.

The general influence of the temperature over pH is very low, and from Figure 22 it can be observed that the time variations are small; the general values are between 6.4 and 7.2, a domain fit for biogas production in relatively large quantities.

From Figure 23 it can be observed that the municipal residues batch had produced the largest quantity of biogas during the process. The first two batches had the smallest biogas values because of the large content is lingo-cellulose which was very difficult to break during the process, such making wood residues not feet to this technology.

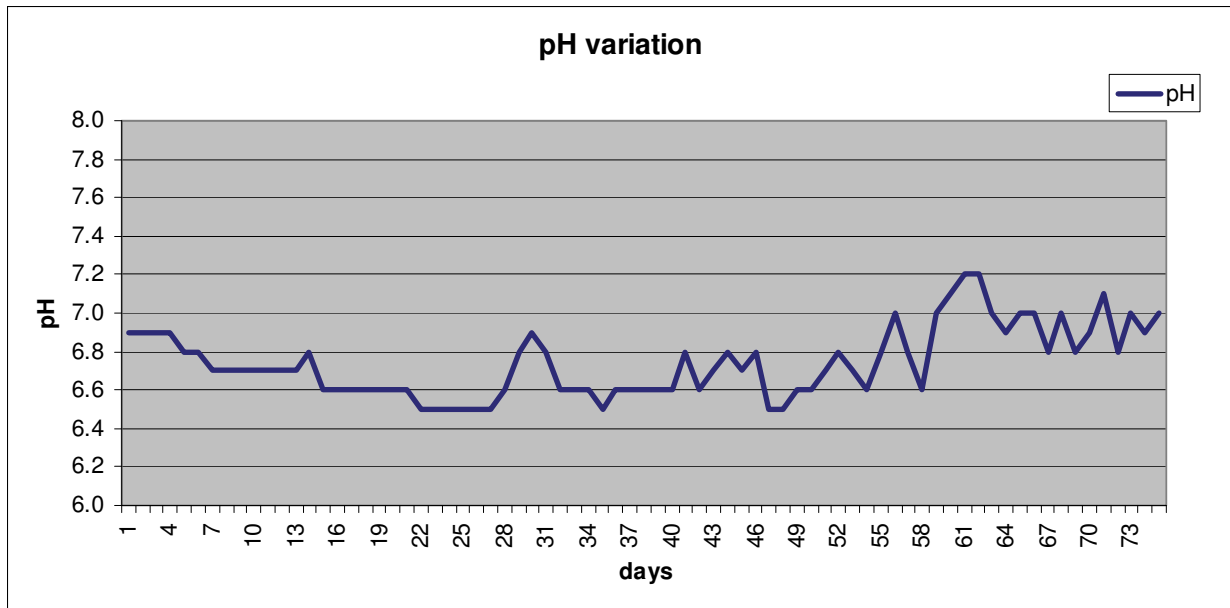

Fig. 22. pH variation

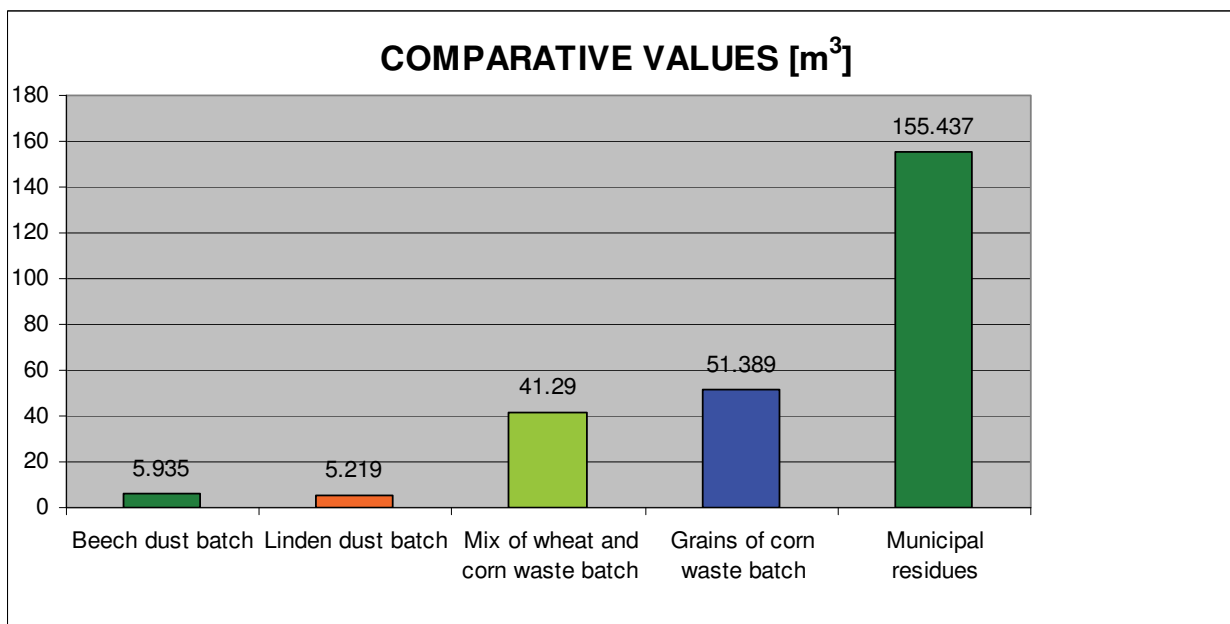

Fig. 23. Comparative values for the batches of used material

The third and fourth batches of material had large quantities of starch, giving them the potential to be used with good results both in quality and quantity related to the biogas production process. Because the fact that the mix of degraded material showed a lower value for biogas production than the corn waste batch, the main idea which can be traced is that wheat is not as suited material as corn for the anaerobic fermentation process.

Also, related with the biogas production from municipal residues there are needed studies in order to determine the exact potential of this kind of substrate for biogas production, especially related with an accurate composition of the used material.

### 3.5 Possibilities of using the biogas in internal combustion engines

Power generation by using gas fueled engines is widely spread around the world, especially in remote areas with no electric power transport infrastructure. Combined heat and power generation increases overall efficiency and provides environmental as well as economical benefits.

Several operating strategies are investigated, with different air-fuel ratios for a stationary engine. CO<sub>2</sub>, CO and NO<sub>x</sub> emissions values were calculated and the effect of methane content in the fuel is evaluated. A reduction of both NO<sub>x</sub> and CO emissions values is noticed as the biogas methane content decreases, while carbon dioxide emissions are lower for methane rich biogas.

Dedicated lean-burn, turbo-charged spark ignition gas engines can reach electrical efficiency of 45% due to special features including combustion optimization and high mechanical efficiency through reduced losses (Hunt, 2009). Engines like MAN's 5-8 MW 32/40 PGI power generation gas engine with a completely new high-energy ignition system, combine the advantages of diesel engines, high efficiency and power density, with the low emissions of gas engines. Given this operation mode, where a small quantity of gas is injected into a pre-chamber to be ignited on a hot surface, electrical efficiency is as high as 46%, while NO<sub>x</sub> emissions are less than 250 mg/Nm<sup>3</sup> at 5% O<sub>2</sub> (Hunt, 2008).

When considering fuel sources, methane is the most environmentally friendly fossil fuel, with minimum CO<sub>2</sub> emissions. While diesel engines deliver high efficiencies up to 50%, nitrous oxide emissions are high and require the use of selective catalytic reduction exhaust gas treatment. Gas engines feature less CO<sub>2</sub> emissions and very low NO<sub>x</sub> emissions, under 1 g/kWh without any exhaust gas treatment.

Spark ignition engines are a major source of air pollution due to the exhaust gases that contain nitrous oxides (NO and NO<sub>2</sub> collectively known as NO<sub>x</sub>), carbon monoxide (CO), and organic compounds which are unburned or partially burned hydrocarbons (HC) (Ionel et al., 2006).

Nitrous oxide emissions (NO<sub>x</sub>) are comprised of nitric oxide (NO) and nitrogen dioxide (NO<sub>2</sub>). Out of the two species, NO is predominant with the major source being the oxidation of atmospheric nitrogen. The quantity of NO in the exhaust gas stream is given by the kinetics of formation and dissociation reactions, often called the extended Zeldovich mechanism. Reasonable NO formation rates can be modeled using equation (5) (Heywood, 1988).

$$\frac{d[NO]}{d\tau} = \frac{6 \cdot 10^{16}}{T^{0,5}} \frac{1}{e^{69090/T}} [O_2]_e^{0,5} [N_2]_e \quad (5)$$

where  $d[NO]$  is the variation of nitric oxide molar concentration measured in mol/cm<sup>3</sup> s,  $d\tau$  the variation of time in s,  $T$  local temperature in K,  $[O_2]_e$  and  $[N_2]_e$  are oxygen and nitrogen concentrations at chemical equilibrium measured in mol/cm<sup>3</sup>.

A strong dependence between NO formation and temperature is evident through the exponential term. Local temperature during combustion and the expansion stroke can be simulated using a flame let model that predicts a drop in mean effective pressure with decreasing methane content (Figure 24).

Another influence factor is the equivalence ratio or excess air ratio ( $\lambda$ ), quantified by O<sub>2</sub> and N<sub>2</sub> molar equilibrium concentrations. This influence becomes important when operating the engine on lean mixtures with certain types of fuels, like power gas. Exhaust gas recirculation

indirectly affects NO formation by lowering temperature values during combustion, greatly reducing NO<sub>x</sub> emissions even when hydrogen enriched fuel is used.

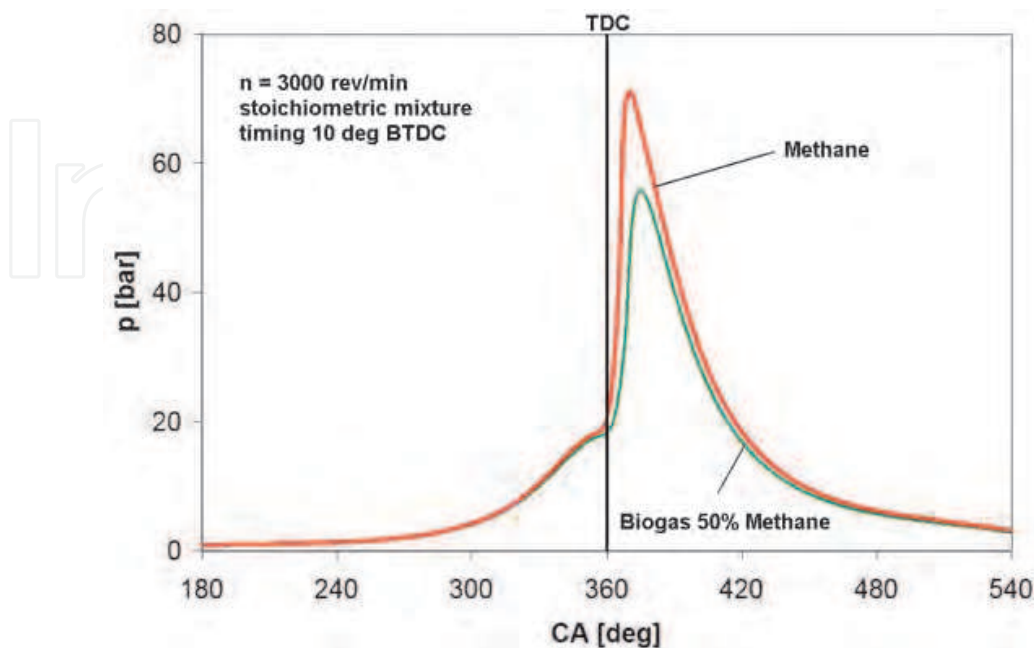
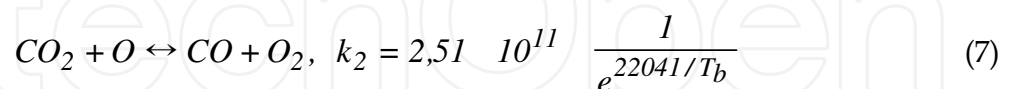
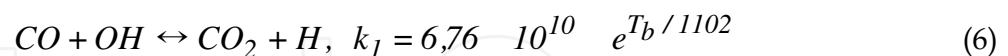

Fig. 24. Simulated pressure traces vs. crank angle rotation for methane and biogas with 50% methane content during compression and expansion strokes (Cioabla, 2009)

Carbon monoxide emission values are kinetically controlled, as the reaction rate of oxidation to CO<sub>2</sub> is slow compared to the CO formation rate. CO concentrations measured for rich mixtures are in good agreement with predicted equilibrium values, while at close to stoichiometric mixtures a correction is necessary. The CO oxidation and formation mechanism can be modeled with specific reaction rates as described by equations (6) and (7) (Papagiannakis et al., 2007).



where  $k_1, k_2$  are reaction rates measured in m<sup>3</sup>/kmol s, and  $T_b$  is the burned gas temperature in K.

The presence of CO<sub>2</sub> in biogas has a similar effect on NO<sub>x</sub> emissions as exhaust gas recirculation, as temperature values during combustion are lower for biogas with high carbon dioxide content (Figure 25). A significant reduction of NO formation is noticed for the entire excess air ratio range as the biogas is richer in CO<sub>2</sub>. Of course, the presence of CO<sub>2</sub> leads to a drop in efficiency because of longer combustion due to a lower flame speed, and an increase of unburned hydrocarbon emissions. The model predicts a peak in NO<sub>x</sub> values for slightly lean mixtures (Figure 26), in good agreement with experimental data. Simulated maximum values however, are higher than those actually measured.

CO emissions drop as the methane content decreases (Figure 27), mainly due to lower combustion temperatures and because there is less carbon available for oxidation.

Evidently, less carbon dioxide is present in the exhaust gas stream, as methane content is higher (Figure 28). It must be noted however, that biogas is a CO<sub>2</sub> neutral energy source.

Having in mind the character of this fuel we can determine the CO<sub>2</sub> quantity that can be reduced by not going to be dispersed in the atmospheric air in case of using fossil fuels.

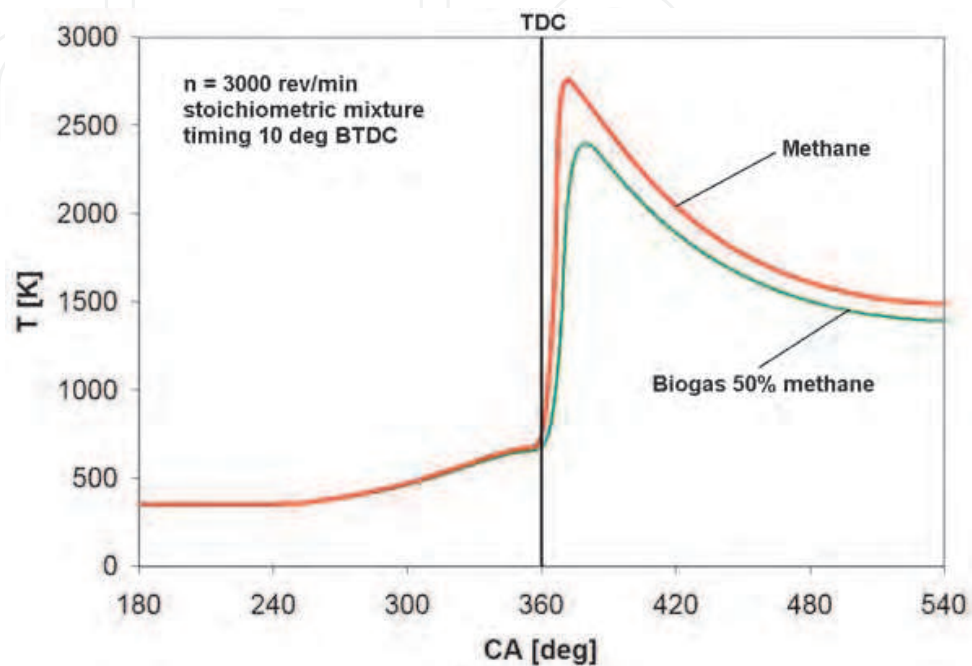

Fig. 25. Simulated temperature values vs. crank angle rotation for methane and biogas with 50% methane content during compression and expansion strokes (Cioablă, 2009)

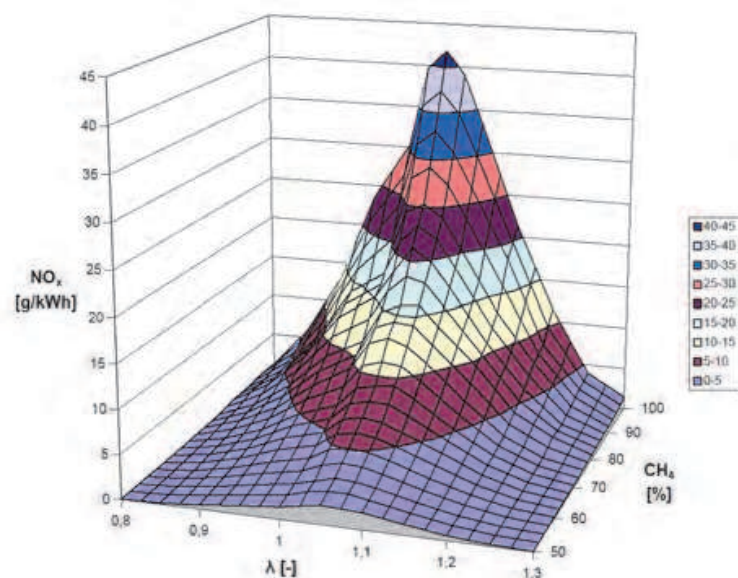

Fig. 26. Calculated NO<sub>x</sub> emissions for different biogas quality values, engine speed 3000 rev/min (Cioablă, 2009)

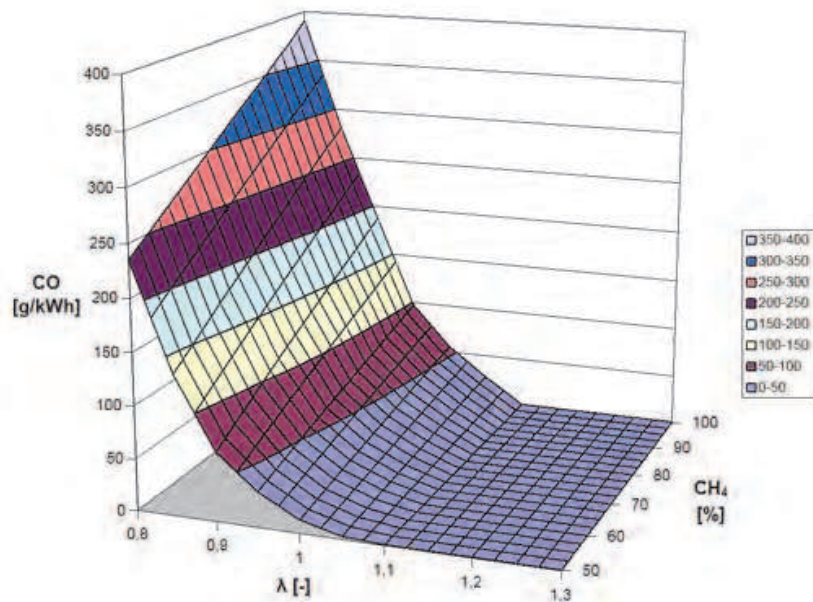

Fig. 27. Calculated CO emissions for different biogas quality values, engine speed 3000 rev/min (Cioablă, 2009)

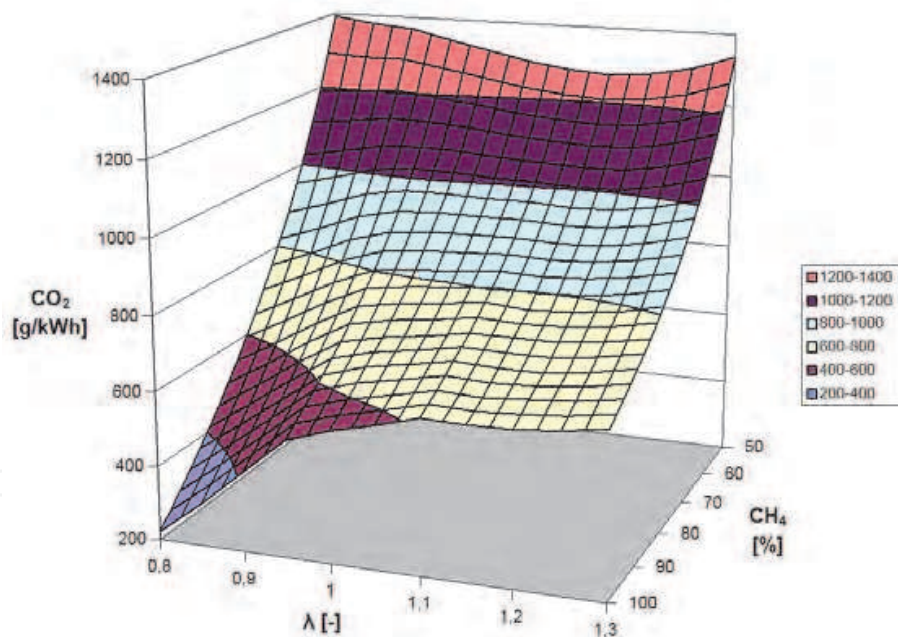

Fig. 28. Calculated CO<sub>2</sub> emissions for different biogas quality values, engine speed 3000 rev/min (Cioablă, 2009)

For low power electrical generators driven by spark-ignition engines in general gasoline, liquefied petroleum gas (LPG) or natural gas are used.

Electric power generated by using a spark ignition engine (MAS) can be calculated with relation (8), where the effective yield ( $\eta_e$ ) ranges from  $\sim 30\%$  under full load operation. Higher values of this efficiency (up to  $\sim 39\%$  and even higher) can be obtained for MAS supercharged operating with very lean air-fuel mixture at low speed  $\sim 1500$  rpm and have a

high compression ratio. Such engines are limited to operation with natural gas due to high tendency to detonation (Ungureanu & Ionel, 1993).

$$P_e = \eta_g \cdot \eta_e \cdot \dot{m}_{fuel} \cdot H_i \quad (8)$$

where:

$P_e$  - the electrical power [W],

$\eta_g$  - electric generator efficiency [-]

$\eta_e$  - actual performance engine [-]

$\dot{m}_{fuel}$  - fuel flow [kg / s]

$H_i$  - fuel calorific value [J / kg].

Internal combustion engine which causes the electric generator requires more maintenance and repairs at regular intervals. Thus, a number of operating hours are necessary to change the oil, the various components of the ignition system, change filters etc.. All these operations effectively reduce the time the engine can be exploited, and the actual operation is reduced compared with the life of unit.

The electricity that can be produced depends on the size of the biogas plant. For small biogas plants, as is the case with the experimental installation on which measurements were made, the power internal combustion engine is on the order of 2.5 kW. For an effective power of the engine ( $P_e$ ) of 2.2 kW, the actual yield ( $\eta_e$ ) is the internal combustion engine of 30%, an effective operating coefficient ( $\eta_f$ ) for a yield of 76% and the electric generator ( $\eta_g$ ) is 98%. A comparison of CO<sub>2</sub> emissions can be made (Table 4) in case of using gasoline ( $H_i \sim 43,500$  kJ / kg) or natural gas ( $H_i \sim 50,000$  kJ / kg). Obviously the use of biogas in CO<sub>2</sub> emission is practically zero. There is a higher amount of annual emissions of CO<sub>2</sub> in using gasoline compared to the situation when is used natural gas, which is explained by the higher carbon content of gasoline ( $\sim 0.854$  per kg of bodyweight / kg<sub>fuel</sub>) compared with methane (0.75 per kg of bodyweight / kg<sub>fuel</sub>), this being the main component of natural gas.

Fuel	$P_e$ [kW]	$\eta_e$	$\eta_g$	$\eta_f$	$m_{fuel}$ [kg]	CO <sub>2</sub> emission [t/year]
Gasoline	2,2	0,3	0,98	0,76	7131	22329
Natural gas					6203	17058

Table 4. Calculated CO<sub>2</sub> annual emission

Obviously, for an installation which produces electricity and recovers some of the heat evacuated from the engine by using a heat exchanger mounted on the exhaust path, it can be obtained a very high efficiency in the cogeneration system and the potential reduction of CO<sub>2</sub> emission. This is much higher compared to where MAS is used to generate electricity and a central heating is used to get heat. Overall efficiency heat exchangers ( $\eta_{sc}$ ) have the maximum values of  $\sim 70\%$  but this figure varies widely depending on the parameters, which are operated this way for recovering the heat contained in exhaust gases. Another important aspect is the evaluation of the heat to maintain a proper temperature so that the bioreactor provided an environment conducive to development of methanogenic bacteria. Thus, although efficiency of energy production in cogeneration system has high values (around 80%), overall plant efficiency is lower due to the loss of heat needed to maintain optimum temperature in fermentation tanks.



#### 4. Conclusions

Biomass represents an inexhaustible energy resource that can be used partly or wholly for biogas production, both by anaerobic fermentation and other processes (aerobic fermentation, gasification);

Biogas has the potential to become an alternative fuel for the existing fossil fuels related with the field of applications already existing today and developing for the future;

Biogas plants can be of different sizes, thus ensuring the energy needs at both individual (flat, firm) and industry level, with the cost investment depreciation in a reasonable time;

Regionally and globally, stimulated investments are linked to the achievement of plants to produce biogas, a shift in which our country should join the current conditions;

The purity of produced biogas is closely related to the type of biomass used, and a very important element to monitor besides methane and carbon dioxide is the traces of hazardous gases ( $H_2S$ );

Washing of produced biogas by spraying water in special filters helps to increase the percentage of methane contained in evacuated, percentage whose influence is reflected in the calculation of calorific value of gas fuel;

Main parameters of influence on the anaerobic fermentation process is the temperature at which the process is done, the pH of slurry, elementary chemical composition of the materials used and the biomass nature;

Reported on the used substrate, it is important to know the mass ratio of solid and liquid used and carbon / nitrogen ratio;

When using wood residues, the main problem is finding a way to break the cellulose chains in order to easily degrade the material during the anaerobic fermentation process with potential good results in terms of biogas quality and quantity;

Connected with the different quantities of produced biogas, the next step of the research involves experimental studies related with using biogas in incineration or co-incineration processes with applications in burners or small engines. The main objective of the research is to determine the composition of the flue gas and the real potential of using the obtained biogas in incineration processes;

Presently, studies are achieved in order to improve the possibilities of obtaining good quality and quantities of biogas from different sources of municipal residues the results representing environmental friendly option for supporting applications in co-incineration and agriculture where the resulted substrates can be used .

#### 5. References

- Amon, T. et al. (2007). Biogas production from maize and dairy cattle manure - Influence of biomass composition of the methane yield, *Agriculture Ecosystems and Environment*, 118 (2007), pp. 173 - 182, ISSN 0167 - 8809
- Busch, G.; et al. (2008). A New and Sound Technology for Biogas from Solid Waste and Biomass, *Water Air Soil Pollut: Focus* (2009) 9:89-97 DOI 10.1007/s11267-008-9195-5
- Cioablă, A. E. (2009). *Theoretical and experimental contributions concerning biogas production from biomass residues*, PhD Thesis, Politehnica Publishing House, Timisoara
- Cioablă, A. E.; Ionel, I; Pădurean, I.; Țenchea, A.; Popescu, F. & Savu, A. (2009). Biogas production from agricultural residues. Test rig and results, *Metalurgia Internațională*, Vol. XIV, No. 3, pp. 40 - 44, ISSN 1582 - 2214

- Deublein, D & Steinhauser, A. (2008). *Biogas from waste and renewable resources, an introduction*, ISBN 978 - 3 - 527 - 31841 - 4
- Hansen, C. L. & Cheong, D. Y. (2007). Agricultural waste management in food processing, *Handbook of Farm, Dairy, and Food Machinery*
- Heinimo, J. (2008). Views on the international market for energy biomass in 2020: results from a scenario study, *International market for energy biomass*, 547, ISSN 1750 - 7220
- Heywood, J. B. (1988) Internal Combustion Engines Fundamentals, *Mc-Graw Hill Series in Mechanical Engineering*
- Hunt, J. (January-February 2008). Reciprocating engines continue to evolve. *Cogeneration & On-Site Power Production*, Volume 10, No 1, pp. 39-47, ISSN 1469-0349
- Hunt, J. (March-April 2009). Cleaner, more power and heat, less fuel-today's engines must deliver. *Cogeneration & On-Site Power Production*, Vol. 10, No 2, pp. 23-29, ISSN 1469-0349
- Igoni, A.H. et al. (2008), Designs of anaerobic digesters for producing biogas from municipal solid waste, *Applied energy*, 85 (2008), pp. 430 - 438, ISSN 0306 - 2619
- Ionel, I.; Ungureanu, C.; et al. (2006). *Thermo energy and environment*, Ed. 2<sup>a</sup>, Ed. Politehnica Publishing House, ISBN: (10) 973-625-387-2, Timisoara
- Ionel, I. & Cioabla, A. E. (2010). Biogas production based on agricultural residues. From history to results and perspectives, *WSEAS Transactions on Environment and Development*, Issue 8, Vol. 6, pp. 591 - 603, ISSN 1790 - 5079
- Karellas et al. (2010), Development of an investment decision tool for biogas production from agricultural waste, *Renewable and sustainable energy reviews*, 14 (2010), pp. 1273 - 1282, ISSN 0364 - 0321
- Li, I. et al. (2011), Solid state anaerobic digestion for methane production from organic waste, *Renewable and sustainable energy reviews*, 15 (2011), pp. 821 - 826, ISSN 0364-0321
- Papagiannakis, R. G.; Rakopoulos, C. D.; Hountala, D. T. & Giakoumis, E. G. (2007). Study of the performance and exhaust emissions of a spark-ignited engine operating on syngas fuel, *International Journal of Alternative Propulsion*, Vol. 1, Nr. 2/3, ISSN 1741-8011
- Petersen, J. E. (2008). Energy production with agricultural biomass: environmental implications and analytical challenges, *European Review of Agricultural Economics*, Vol 35 (3), ISSN 0165 - 1587
- Romanian statistical register (2007)
- Ungureanu, C. & Ionel, I. (1993). *Steam generators. Thermal calculation*, Politehnica Publishing House, Timisoara,
- Walla, C. & Schneeberger, W.(2008), The optimal size for biogas plants, *Biomass and bioenergy*, 32 (2008), pp. 551- 557, ISSN 0961 - 9534
- Weiland, P. (2009). Biogas production: current state and perspectives, *Appl Microbiol Biotechnol*, DOI 10.1007/s00253-009-2246-7
- Wu, H. et al. (2009), The effect of pH on anaerobic fermentation of primary sludge at room temperature, *Journal of hazardous materials*, 172 (2009), pp. 196 - 201, ISSN 0304 - 3894

Yadvika et al. (2004), Enhancement of biogas production from solid substrates using different techniques - a review, *Bioresource technology*, 95 (2004), pp. 1 - 10, ISSN 0960 - 8524

IntechOpen

IntechOpen

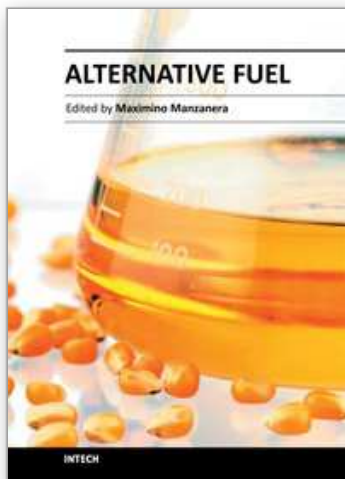

## **Alternative Fuel**

Edited by Dr. Maximino Manzanera

ISBN 978-953-307-372-9

Hard cover, 346 pages

**Publisher** InTech

**Published online** 09, August, 2011

**Published in print edition** August, 2011

Renewable energy sources such as biodiesel, bioethanol, biomethane, biomass from wastes or hydrogen are subject of great interest in the current energy scene. These fuels contribute to the reduction of prices and dependence on fossil fuels. In addition, energy sources such as these could partially replace the use of what is considered as the major factor responsible for global warming and the main source of local environmental pollution. For these reasons they are known as alternative fuels. There is an urgent need to find and optimise the use of alternative fuels to provide a net energy gain, to be economically competitive and to be producible in large quantities without compromising food resources.

### **How to reference**

In order to correctly reference this scholarly work, feel free to copy and paste the following:

Adrian Eugen Cioablă and Ioana Ionel (2011). Biomass Waste as a Renewable Source of Biogas Production - Experiments, *Alternative Fuel*, Dr. Maximino Manzanera (Ed.), ISBN: 978-953-307-372-9, InTech, Available from: <http://www.intechopen.com/books/alternative-fuel/biomass-waste-as-a-renewable-source-of-biogas-production-experiments>

**INTECH**  
open science | open minds

### **InTech Europe**

University Campus STeP Ri  
Slavka Krautzeka 83/A  
51000 Rijeka, Croatia  
Phone: +385 (51) 770 447  
Fax: +385 (51) 686 166  
[www.intechopen.com](http://www.intechopen.com)

### **InTech China**

Unit 405, Office Block, Hotel Equatorial Shanghai  
No.65, Yan An Road (West), Shanghai, 200040, China  
中国上海市延安西路65号上海国际贵都大饭店办公楼405单元  
Phone: +86-21-62489820  
Fax: +86-21-62489821

© 2011 The Author(s). Licensee IntechOpen. This chapter is distributed under the terms of the [Creative Commons Attribution-NonCommercial-ShareAlike-3.0 License](#), which permits use, distribution and reproduction for non-commercial purposes, provided the original is properly cited and derivative works building on this content are distributed under the same license.

IntechOpen

IntechOpen