

# We are IntechOpen, the world's leading publisher of Open Access books Built by scientists, for scientists

4,800

Open access books available

122,000

International authors and editors

135M

Downloads

Our authors are among the

154

Countries delivered to

TOP 1%

most cited scientists

12.2%

Contributors from top 500 universities



WEB OF SCIENCE™

Selection of our books indexed in the Book Citation Index  
in Web of Science™ Core Collection (BKCI)

Interested in publishing with us?  
Contact [book.department@intechopen.com](mailto:book.department@intechopen.com)

Numbers displayed above are based on latest data collected.  
For more information visit [www.intechopen.com](http://www.intechopen.com)



# Novel Electroceramic: Polymer Composites - Preparation, Properties and Applications

Padmaja Guggilla and Ashok K. Batra  
*Alabama A&M University,  
USA*

## 1. Introduction

Engineers consistently demand new material systems, vital in emerging novel technological applications. Thus, this demand dictates that material scientists develop new material systems. The modern electronic devices and systems require diverse and specific functional properties in materials; which cannot be met in single-phase materials (Batra et al., 2008). Composite technology, where a novel functional material is fabricated by combining two or more chemically different materials or phases, for example, ceramics and polymers in an ordered manner or just mixing, is playing an important starring role. In recent decades, a large number of ceramic-polymer electronic composites have been introduced for medical, telecommunication and microelectronics applications, and devices ranging from micro-mechanical systems (MEMS; Bio-MEMS) through sensors and actuators (Taya, 2008). The composites have a unique blend of polymeric properties such as mechanical flexibility, high strength, design flexibility and formability, and low cost, with the high electro-active functional properties of ceramic materials. In these materials, it is, thus, possible to tailor, physical, electronic and mechanical properties catering a variety of applications. As a result, the composite as a whole is described using a set of microstructural characteristics, for example, connectivity, volume fractions of each component, spatial distribution of the components, percolation threshold and other parameters. Thus, the response of an electronic composite (electroceramic-polymer) to an external excitation (electric field, temperature, stress, etc.) depends upon the response of individual phases, their interfaces as well as the type of connectivity. As a result, an Electronic Composite can be broadly be described as exhibiting electromagnetic, thermal, and/or mechanical behavior while maintaining structural integrity (Taya, 2008).

With a recent progress in nano- science and technology, there is an increasing interest in polymer nano-composites both in scientific and in engineering applications (Kochary et al., 2008; Guggilla et al., 2009; Sebastian et al., 2010), therefore, a brief account of their electronic properties and applications will discussed. In the light of many technologically important applications in this field, the proposed chapter will be exhaustive and complete in all respects for naive to seasoned scientists.

## 2. Composite materials with piezoelectric, ferroelectric and pyroelectric functionalities

All crystals can be categorized into 32 different classes. These classes are point groups divided by using the following symmetry elements: (1) Center of symmetry, (2) axes of rotation, (3) mirror planes, and (4) several combinations of them. The 32 point groups are subdivisions of 7 basic crystal systems that are, in order of ascending symmetry, triclinic, monoclinic, orthorhombic, tetragonal, rhombohedral (trigonal), hexagonal, and cubic. Of the 21 classes of the 32 point groups that are noncentrosymmetric, which is a necessary condition for piezoelectricity to exist, 20 of them are piezoelectric. Of the 20 piezoelectric crystal classes, 10 crystals have pyroelectric properties. Within a given temperature range, this group of materials is permanently polarized. Compared to the general piezoelectric polarization produced under stress, the pyroelectric polarization is developed spontaneously and kept as permanent dipoles in the structure. As this polarization varies with temperature, the response is termed as pyroelectricity. The ferroelectric group is a subgroup of the spontaneously polarized pyroelectric crystals. Though the polarization of ferroelectric is similar to the polarization of pyroelectric, there is a difference in the two polarizations because the ferroelectric polarization is reversible by an external applied electric field, provided that the applied field is less than the dielectric breakdown of the materials. Therefore, materials that can be defined as ferroelectrics must have two characteristics: (1) The presence of spontaneous polarization and (2) reversibility of the polarization under an electric field. A ferroelectric material is therefore pyroelectric, piezoelectric, and noncentrosymmetric. It follows that, not all piezoelectric materials are pyroelectric, and not all pyroelectric materials are ferroelectric material as depicted in Figure 1. The Table 1 lists the important ferroelectric/pyroelectric materials being investigated and/or are being used in the various devices (Lal et al., 1993). Figure 1 show some important ferroelectric materials and their uses in various devices based on their unique piezoelectric, pyroelectric, ferroelectric, electro-optic, acousto-optic, and dielectric properties. The most commonly used materials for pyroelectric applications include triglycine sulfate (TGS); lead (Pb) zirconate titanate,  $\text{PbZrTiO}_3$  (PZT); lead titanate,  $\text{PbTiO}_3$  (PT); barium titanate,  $\text{BaTiO}_3$ (BT); lithium (Li) tantalate,  $\text{LiTaO}_3$  (LT); and polymers: poly (vinylidene fluoride) (PVDF) and co-polymers including P (VDF-TrFE) and P (VDF-TFE).

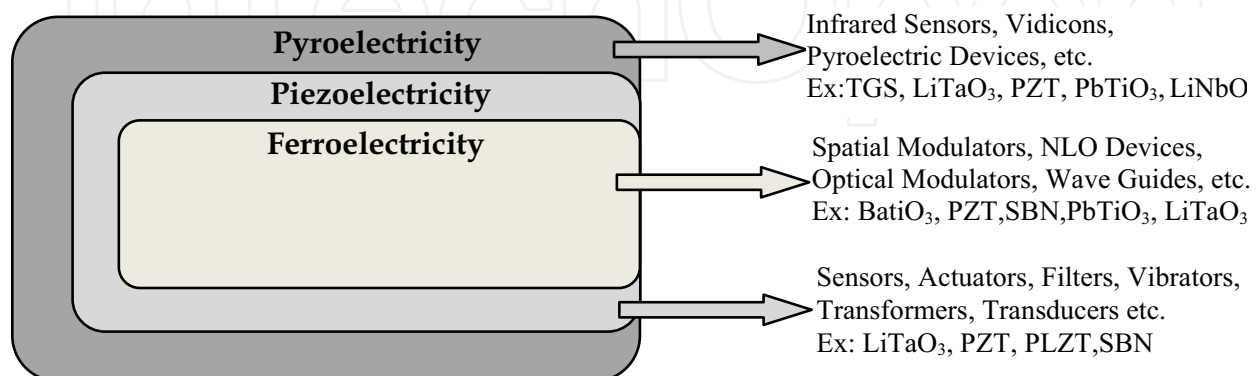

Fig. 1. The relationship between pyro, piezo, and ferroelectricity

Ferroelectrics' Family	Ferroelectric Material	Chemical Formula	Abbreviation
Perovskite type	Barium titanate	BaTiO <sub>3</sub>	BT
	Lead zirconate titanate ceramics)	PbZr <sub>x</sub> Ti <sub>1-x</sub> O <sub>3</sub>	PZT
	Barium Strontium titanate	Ba <sub>x</sub> Sr <sub>1-x</sub> TiO <sub>3</sub>	BST
Lithium niobate	Lithium Niobate	LiNbO <sub>3</sub>	LN
	Lithium Tantalate	LiTaO <sub>3</sub>	LT
Barium Type	Barium Strontium Niobate	Ba <sub>5x</sub> Sr <sub>5(1-x)</sub> Nb <sub>10</sub> O <sub>30</sub>	BSN
TGS type	Triglycine Sulfate	(NH <sub>2</sub> CH <sub>2</sub> COOH) <sub>3</sub> ·H <sub>2</sub> SO <sub>4</sub>	TGS
Polymer	Poly (vinylidene Fluoride )	-	PVDF
	Poly (vinylidene Fluoride-trifluoroethylene)	-	P(VDF-TrFE)

Table 1. List of important pyroelectric materials Investigated/being Investigated for use in various devices

## 2.1 Physics and chemistry of composite materials

There are thousands of materials available for use in engineering applications. Most materials fall into one of three classes that are based on the atomic bonding forces such as metallic, ionic, covalent, and Van der Waals etc. of a particular material; these three classifications are metallic, ceramic and polymeric. Additionally, different materials can be combined to create a composite material. Within each of these classifications, materials are often further organized into groups based on their chemical composition or certain physical or mechanical properties. Composite materials are often grouped by the types of materials combined or the way the materials are arranged together. Figure 2 clearly demonstrates a list of some of the commonly classification of materials within these four general groups of materials (Taya, 2008).

## 2.2 Constituents of composite materials

Composite materials are the materials made up of two or more materials combined together in such a way that the constituent materials are easily distinguished. The composite materials consist of basically three phases as discussed below and presented in Figure 3.

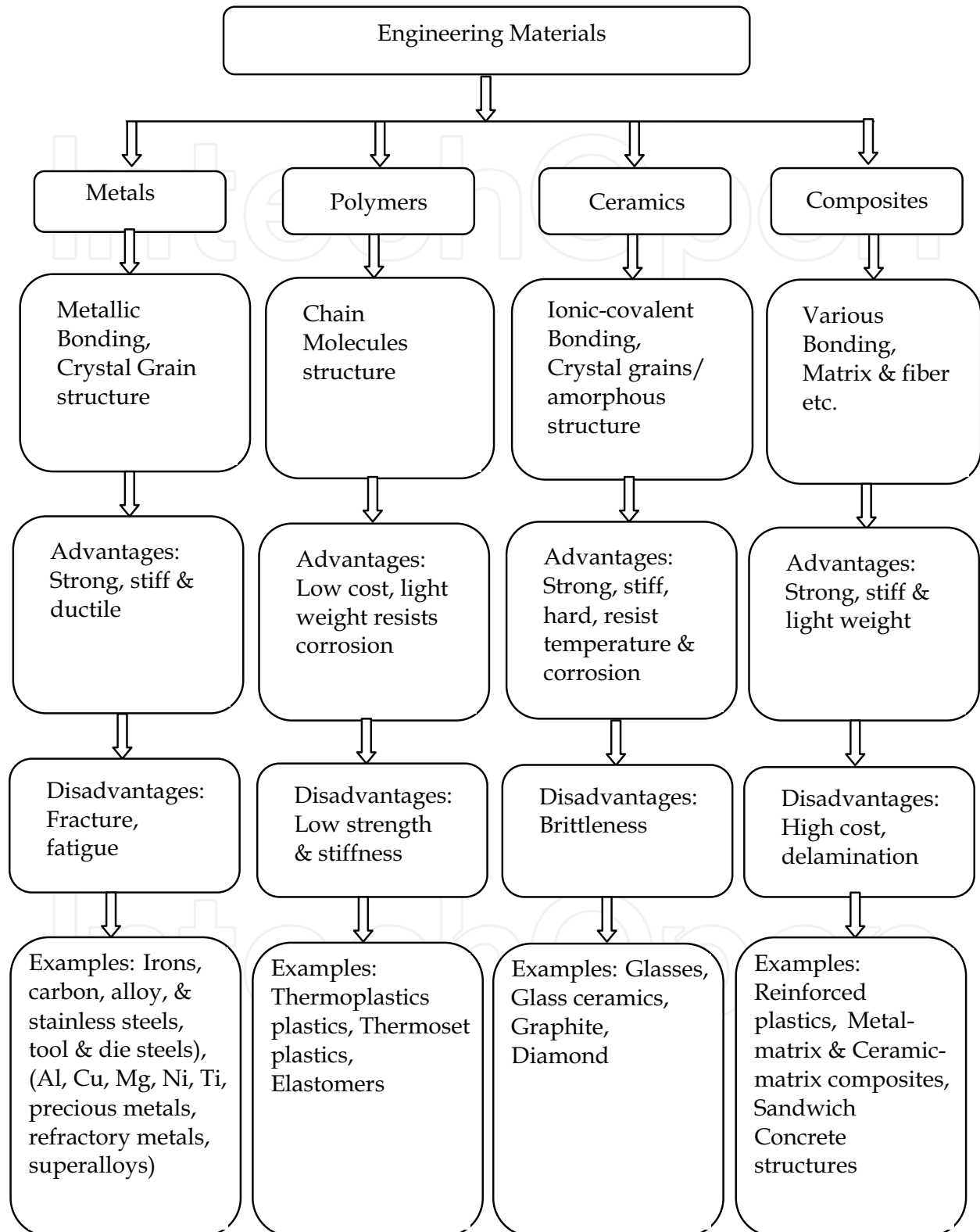

Fig. 2. General characteristics of the major classes of engineering materials

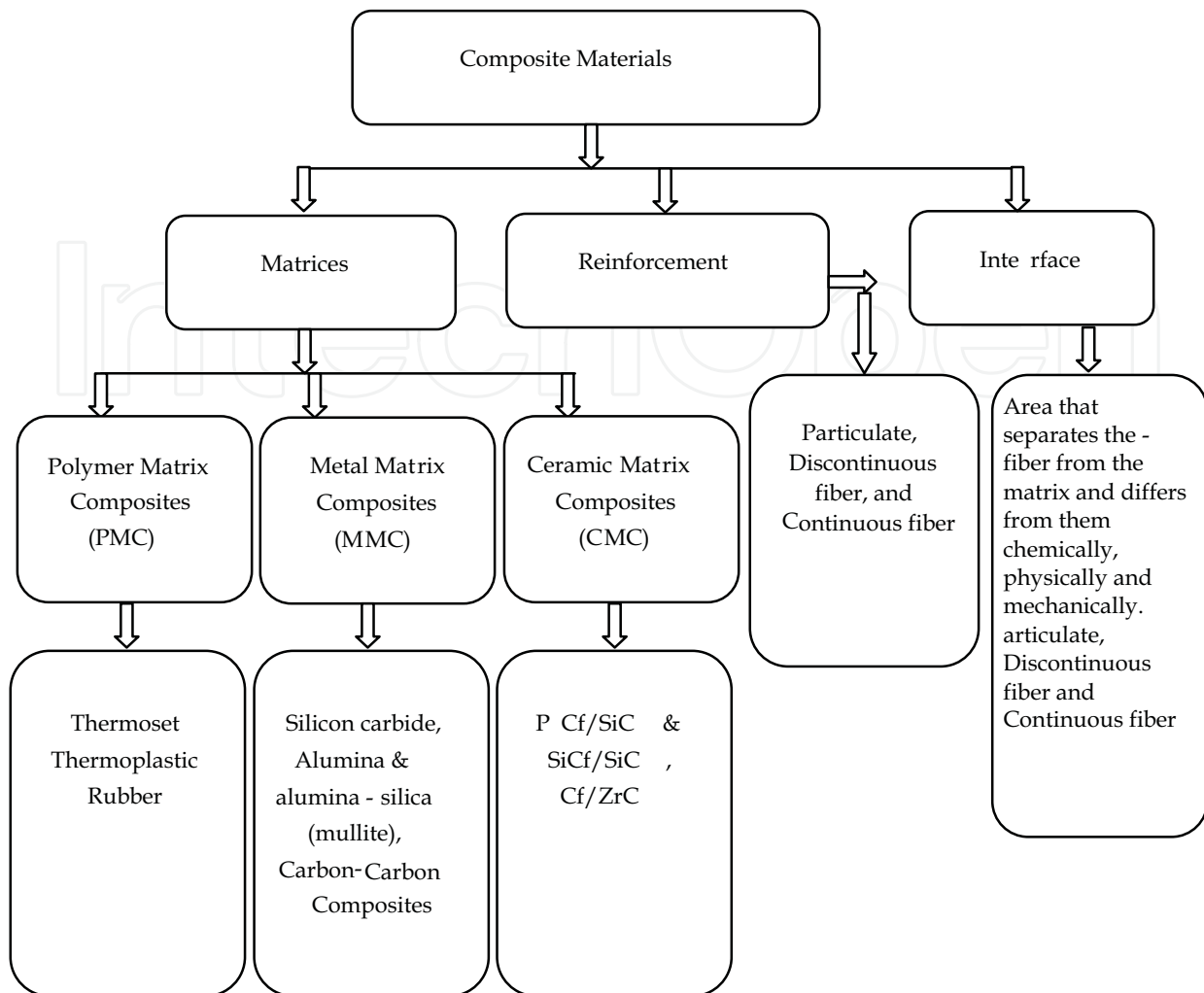

Fig. 3. Composite materials and types of constituents

### 2.2.1 Matrix phase

It is a continuous phase or the primary phase. It holds the dispersed phase and shares a load with it. It is made up of metals, ceramics or polymers depending on the type of composite in investigation.

### 2.2.2 Dispersed (reinforcing) phase

It is the second phase (or phases) which is imbedded in the matrix in a continuous/discontinuous form. Dispersed phase is usually stronger than the matrix, therefore it is sometimes called reinforcing phase in case of structural composites. This reinforcement is a strong, stiff (functional) integral component which is incorporated into matrix to achieve desired properties or functionalities, basically it means desired property enhancement. It can be fiber or particles of any shape and size including nanoparticles as well.

### 2.2.3 Interface

This is the zone across which the matrix phase and reinforcing phases interact (chemical, physical, mechanical, electrical and others). This region in most composite materials has a

finite thickness because of diffusion and/or chemical reactions between the fiber and the matrix.

A multiphase material formed from a combination of materials which differ in composition or form, remain bonded together, and retain their identities and properties. Composites maintain an interface between components and act in concert to provide improved specific or synergistic characteristics not obtainable by any of the original components acting alone. Composites include: (1) fibrous (composed of fibers, and usually in a matrix), (2) laminar (layers of materials), (3) particulate (composed of particles or flakes, usually in a matrix), and (4) hybrid (combinations of any of the above) (Mallick, 1997).

A few common types of composites as listed above are presented in the following Figure 4.

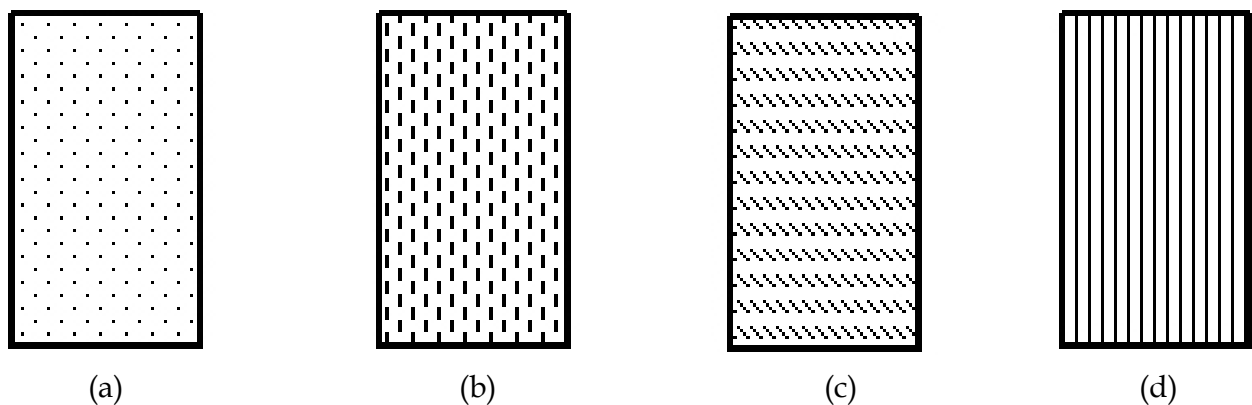

Fig. 4. (a) Particulate and random (b) Discontinuous fibers and unidirectional (c) Discontinuous fibers and random (d) Continuous fibers and unidirectional

### 3. Theory of pyroelectric detector

A pyroelectric detector, based on conversion of photons to phonons to electrons, as shown in Figure 5, is a capacitor whose spontaneous polarization vector is oriented normal to the plane of the electrodes. Incident radiation absorbed by the pyroelectric material is converted into heat, resulting in a temperature variation ( $dT$ ) and thus, the magnitude of the spontaneous polarization. Changes in polarization alter the surface charge of the electrodes, and to keep neutrality, charges are expelled from the surface which results in a pyroelectric current in the external circuit. The pyroelectric current depends on the temperature change with time. Therefore, pyroelectric devices are considered to be 'AC' coupled device. Pyroelectric current ( $I_p$ ) is proportional to Area ( $A$ ) and rate of change of temperature ( $dT/dt$ ) of the detecting element, one can write:

$$I_p = p.A \frac{dT}{dt} \quad (1)$$

where  $p$  is the pyroelectric coefficient. Determining the electrical response of a pyroelectric detector requires analysis of the thermal and electrical circuits and optical parameters. The processes that take place during radiation detection are illustrated in Figure 5.

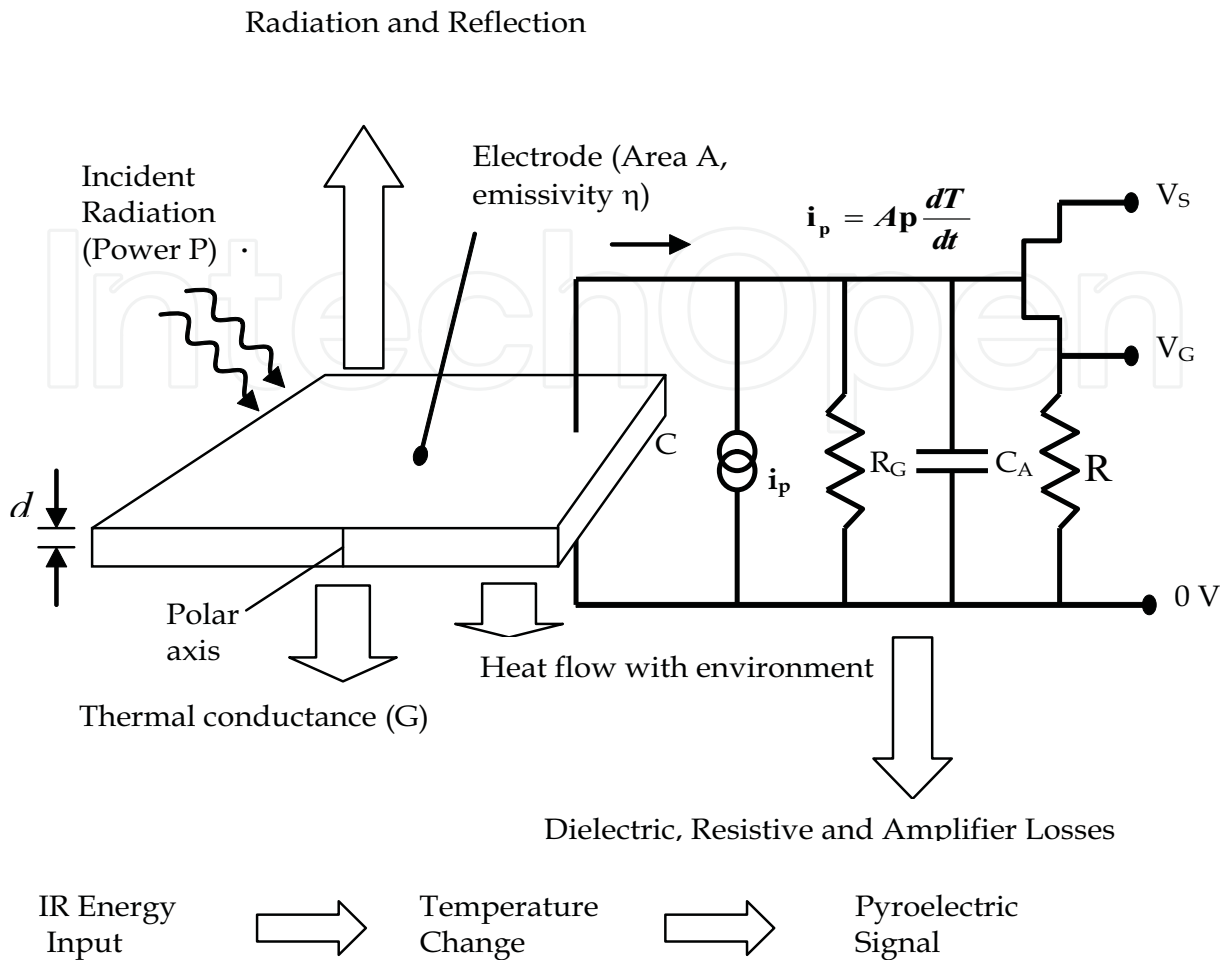

Fig. 5. A Schematic diagram of a pyroelectric detector and detection processes

#### 4. Materials figure-of-merits for infrared detectors

The important properties to look for in sensors are low dielectric constant and loss, high pyroelectric coefficient, and low specific heat. However, important figure-of-merits (F) (Sidney et al., 2000; Lal et al., 1993 and Whatmore et al., 2001) are,

$$F_I = p / c' \quad \text{for high current detectivity,} \quad (2)$$

$$F_V = p / c' \epsilon' \quad \text{for high voltage responsivity,} \quad (3)$$

$$F_D = p / \sqrt{(c' \epsilon'')} \quad \text{for high detectivity,} \quad (4)$$

Where  $p$  is the pyroelectric coefficient,  $c'$  is the specific heat of the element,  $\epsilon'$  is the dielectric constant and  $\epsilon''$  is the imaginary part of dielectric constant (dielectric loss).

Bauer et al., 1991 has developed following the figure-of-merits, when the pyroelectric element is placed on a substrate that is acting as a heat sink i.e. whose thermal conductivity is infinite where  $k$  is the thermal conductivity of the pyroelectric element.



$$F_I = p / k \quad \text{for high current detectivity} \quad (5)$$

$$F_V = p / k\epsilon' \quad \text{for high voltage responsivity} \quad (6)$$

$$F_D = p / \sqrt{k\epsilon''} \quad \text{for high detectivity.} \quad (7)$$

## 5. Novel ceramic: polymer matrix composites

The search for new material systems for piezoelectric and pyroelectric infrared detecting device applications has led to the design of 'ferroelectric: polymer' composites. Recent studies on ceramic-polymer based pyroelectric composites show potential usefulness via large area, lightweight, enhanced strength, and flexible infrared sensing behavior. Thus, composites based on pyroelectric ceramic particles embedded in polymer possess hybrid properties derived from individual components. These hybrid properties include large pyroelectric coefficients of ceramic material and excellent mechanical strength, formability and robustness of the polymer, eventually useful for infrared detectors. Infrared radiation sensors can be generally divided into two classes: i) photon detectors, in which the radiation absorption process directly produces a measurable effect, e.g., generation of photoelectrons or charge carrier pairs in a photoconductor; and ii) thermal detectors, in which absorbed radiation is converted first to heat, which subsequently produces a measurable effect. Pyroelectrics, along with thermocouples, thermopiles, thermistors, and bolometers, belong to the later class. Pyroelectric infrared (PIR) detecting devices have the following advantages over the photon infrared sensors: sensitivity in very large spectral bandwidth limited only by the ability of the sensor to absorb the incident radiation; sensitive in very wide temperature range without the need of cooling; low power requirements; relatively fast response; generally low cost materials; cannot be detected being a passive device; temperature range of operation can be changed by the variation of the amount of the constituents (such as Lead zirconate titanate, Potassium tantalate niobate and others); and suitable for space applications because of light weight consuming less power having no bulky cooling equipment.

The diphasic polymer composites consist of ceramic particles embedded in the polymer matrix. The properties of these composites depend on the following factors: (i) properties of its constituents; (ii) volume fraction of each constituent; (iii) polarizability of particles; and (iv) nature of inter-connecting these particles. Composite materials comprising of ferroelectric material particles embedded in polymer materials with different connectivities have generated great interest among known pyroelectric infrared detecting materials such as lead titanate (PT); lead zirconate titanate (PZT); barium titanate (BT); and triglycine sulfate (TGS) having polymer matrix host poly-vinylidene fluoride (PVDF) or polyvinylidene fluoride-trifluoroethylene [P(VDF-TrFE)], and virgin pyroelectric materials (Dias and Das-Gupta, 1996 and Aggarwal et al., 2010). It is worth mentioning that novel pyroelectric ceramics are defined as nano-ceramics as well.

### 5.1 Pyroelectric composite materials for un-cooled infrared detectors

#### 5.1.1 Importance of pyroelectric composites

Zook and Liu, 1976 proposed that pyroelectric material with a figure-of-merit,  $(p/\sqrt{\epsilon})$ , significantly higher than presently known ferroelectric materials is unlikely to be found. This was based on the fact that relationship:

$$P_o = (k\varepsilon_o C_c / v) \quad (8)$$

where  $P_o$  is the polarization,  $\varepsilon_o$  is the permittivity of free space,  $C_c$  is the Curie constant,  $k$  is the Boltzmann's constant, and  $v$  is the volume per unit dipole, which has been derived by using Devonshire's two-level dipolar effective field model and the Aizu-Lines lattice dynamic effective field model.  $C_c$  and  $v$  are materials dependent, so in order to maximize polarization one has to maximize  $C_c$  or/and minimize the dipole volume  $v$ . As of now, the Curie constant of known ferroelectrics are in the range of  $2 \times 10^5$  to  $5 \times 10^5$  K and minimum polarizable volume seems to have a minimum of approximately  $50 \text{ \AA}^3$ , therefore, finding materials with higher polarization seems unlikely. Increase in performance may be possible by working on 0-3 composites. The figure-of-merit (for high voltage responsivity) of the pyroelectric detector is proportional to pyroelectric coefficient and inversely proportional to dielectric constant of pyroelectric material. To decrease the dielectric constant, efforts have also been made by forming a matrix-void composite. In the forming process only particles are introduced in the matrix so as to decrease the dielectric constants and hence obtain an increase in the figure-of-merit is obtained. Similarly 0-3 connectivity polymer-ceramic composite shall give attractive results.

## 5.2 Theoretical modeling of electronic composites

A number of models have been proposed or used to predict the dielectric constants, piezoelectric and pyroelectric coefficients of mixture of two or more components (Dias and Das-Gupta, 1996; Sidney and Das-Gupta, 2000; Kohler et al., 1998; Tressler et al., 1999). A summary of dielectric constants and pyroelectric coefficients mixtures formulas is described below. Most of the formulas for mixture give expression in terms of dielectric constants of phases, their volume fractions, and depolarization factors of inclusions. A simple case where the mixture rule for calculation of permittivity, using a model of a capacitance consisting of different homogenous dielectrics connected in series or parallel is shown in Figure 6a & 6b respectively along with formulas of permittivity (Newnham et al., 1978 and Tressler et al., 1999). However, in case of one phase consisting of particles dispersed in other matrix phase, the calculations become more complicated because the field distortion caused by a polarized particle depends on its orientation and shape with respect to the applied field. Thus, different formulas have been proposed, and important ones are listed below.

Maxwell-Garnett formula:

$$\varepsilon_{\text{eff}} = \varepsilon_1 \frac{\varepsilon_1 v_1 (1 - A) + \varepsilon_2 (v_2 + A v_1)}{\varepsilon_1 + A v_1 (\varepsilon_2 - n \varepsilon_1)} \quad (11)$$

where  $v_1$  and  $v_2$  are the volume fractions of the matrix and inclusions respectively. The depolarization factor of the inclusions in the direction perpendicular to the capacitance plates is  $A$ .  $\varepsilon_1$  and  $\varepsilon_2$  are the dielectric constant of matrix and inclusions respectively.  $\varepsilon_{\text{eff}}$  is the dielectric constant of the composite. In equation (11), the dielectric properties are calculated from electric-field average taken over both the component of the mixture. Brugemann assumed that in Maxwell-Garnett formula holds in a diluted limit when an infinitesimal amount of inclusions are added in the mixture, which leads to following equation (12), obtained by solving the differential equation solved with proper initial conditions.

Brugemann formula:

$$\frac{\epsilon_{\text{eff}} - \epsilon_2}{\epsilon_1 - \epsilon_2} \left( \frac{\epsilon_1}{\epsilon_{\text{eff}}} \right)^A = v_1 \quad (12)$$

Bottcher introduced a model, in which particles of both the phases are dispersed in an effective medium with dielectric constant  $\epsilon_{\text{eff}}$ . Assuming that the average dipole field due to particles vanishes, the Bottcher formula is obtained. Bottcher formula:

$$\epsilon_{\text{eff}} = \epsilon_1 + (\epsilon_2 - \epsilon_1)v_2 \frac{\epsilon_{\text{eff}}}{\epsilon_{\text{eff}} + (\epsilon_2 - \epsilon_{\text{eff}})A} \quad (13)$$

Looyenga formula:

$$\epsilon_{\text{eff}}^{1-2A} = v_1 \epsilon_1^{1-2A} + v_2 \epsilon_2^{1-2A} \quad (14)$$

In Loovenga's model, it was assumed that the composite behaves similarly as a system containing the same overall composition, but composed of spheres that itself are heterogeneous and having a slight different composition.

In the following formulas  $\phi$  is the volume fraction of phase 2,  $\epsilon_{\text{eff}}$  is the dielectric constant of composite.

Logarithmic formula:

$$\log \epsilon_{\text{eff}} = (1 - \phi)\epsilon_1 - \phi \log \epsilon_2 \quad (15)$$

Wagner formula:

$$\epsilon_{\text{eff}} = \epsilon_1 \frac{2\epsilon_1 + \epsilon_2 + 2\phi(\epsilon_2 - \epsilon_1)}{2\epsilon_1 + \epsilon_2 - \phi(\epsilon_2 - \epsilon_1)} \quad (16)$$

Landauer formula:

$$(1 - \phi) \frac{\epsilon_{\text{eff}} - \epsilon_1}{2\epsilon_{\text{eff}} - \epsilon_1} + \phi \frac{\epsilon_{\text{eff}} - \epsilon_2}{2\epsilon_{\text{eff}} + \epsilon_2} = 0 \quad (17)$$

Banno formula:

$$\epsilon_{\text{eff}} = \frac{a^2(a + (1-a)n)^2 \epsilon_1 \epsilon_2}{a\epsilon_2 + (1-a)n\epsilon_1} + (1 - a^2(a + ((1-a)n))\epsilon_2) \quad (18)$$

$$\phi = a^3$$

Pletto Formula:

$$\epsilon_{\text{eff}} = (1 - \phi) \frac{\phi\epsilon_1 A^2 + (1 - \phi)\epsilon_2}{(1 + \phi(A - 1))^2} + \phi \frac{\phi\epsilon_1 + (1 - \phi)\epsilon_2 B^2}{(\phi + (1 - \phi)B)^3} \quad (19)$$

where

$$A = \frac{3\epsilon_2}{\epsilon_1 + 2\epsilon_2}$$

$$B = \frac{3\epsilon_1}{2\epsilon_1 + \epsilon_2}$$

### 5.3 Design of composites - connectivity models

For fabrication of a composite, properties of the components, amount of each phase present, and how they are interconnected viz connectivity, are important. Newnham et al., 1978 and Tressler et al., 1999 proposed the concept of connectivity. Any phase in a mixture can be self-connected in zero, one, two, and three dimensions. For example, inclusions dispersed in a polymer host material shall have connectivity 0 while host polymer shall have connectivity 3. Thus, we can say composite with connectivity 0-3 or 0-3 composites. In a two phase composite system, there can be ten different connectivities, which are 0-0, 0-1, 0-2, 0-3, 1-1, 1-2, 1-3, 2-2, 2-3, and 3-3. In this format, first digit denotes the connectivity of inclusions and second digit denotes the host. Generally, the host is a polymer in case of polymer composites. A few connectivities are presented in Figure 7 using a cube as a building block along with real examples. Based on the above concept, in 0-3 connectivity composite, there is random distribution of active particulates in a 3D host polymer matrix.

## 6. Fabrication of polymer-ceramic composites

The 0-3 connectivity composites are easy to fabricate, which allows for commercial production of these composites in a cost effective manner (Nalwa, 1995). The composites which have shown some promising results and are prepared by simple composite fabrication routes are described in this section. As a result, most composites are fabricated as an active piezoelectric and polymer based diphasic samples. Polymer component can be polar or non-polar polymers. The second more popular approach is using the sol gel

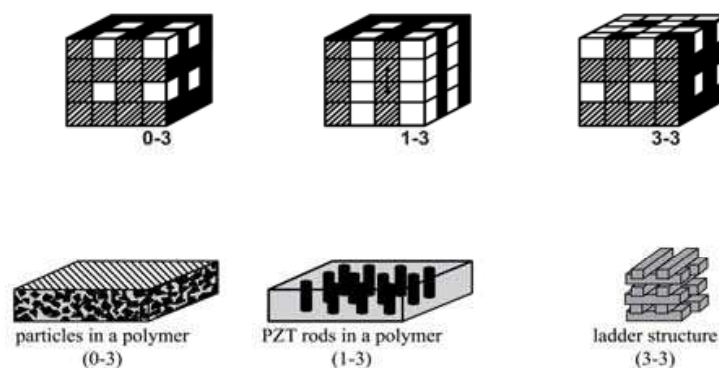

Fig. 7. Connectivity Models (Newnham et al., 1978)

synthesis route. Though the glass-ceramics have also shown noticeable piezoelectric sensing elements, this section doesn't include specific descriptions section on such materials. The 0-3 connectivity composite may be prepared by mixing the ceramic particles in a hot rolling mill with softened thermoplastic polymer, and thin films of composites then be produced by high-pressure casting at softening temperature of the polymer. With a thermo-set polymer such as epoxy, the mixing can be made at room temperature with the right proportion of the resin, hardener and the ceramic powder (Nalwa, 1995 and Yamazaki and Tayama, 1981).

In solvent casting, first a polymer is dissolved in a suitable solvent and then electro-active ceramic powder is added and mixed/dispersed. A mixture so obtained is kept in a suitable container for solvent to evaporate. The film so obtained is hot pressed at crystallization temperature of the polymer. The problems are faced during the mixing operation, which are linked to a poor distribution of the ceramic inclusions, poor adhesion of component phases

or air bubbles in the composites. An agglomeration of ceramic particles is also present in the solution, which may be overcome by lowering the polymer viscosity via heating during the ultrasonic mixing process. For the fabrication of 0-3 connectivity composites films using spin coating technique. A typical example for the preparation of P (VDF-TrFE): PZT composite, first of all, a suitable amount of polymer, P (VDF-TrFE) is dissolved in methyl-ethyl-ketone (MEK) to form a solution (PMix). A requisite amount of nano-ceramic (PZT) powder is then added and the mixture is ultrasonically agitated for several hours to break-up the agglomerates and to disperse the ceramic powder uniformly in the copolymer solution. With this composite solution (nPMix), a thin film can be deposited on conducting electroded substrate using a spin coating technique. The steps involved in fabricating films by spin coating are illustrated in Figure 9. The film is then annealed for 2-3 hours in air at 130 °C for the present case and top electrode is deposited for testing (Abdullah and Das-Gupta, 1988 & 1990; Abdullah, 1989). The flow chart illustrating various steps involved in fabricating composite films are shown in Figure 8.

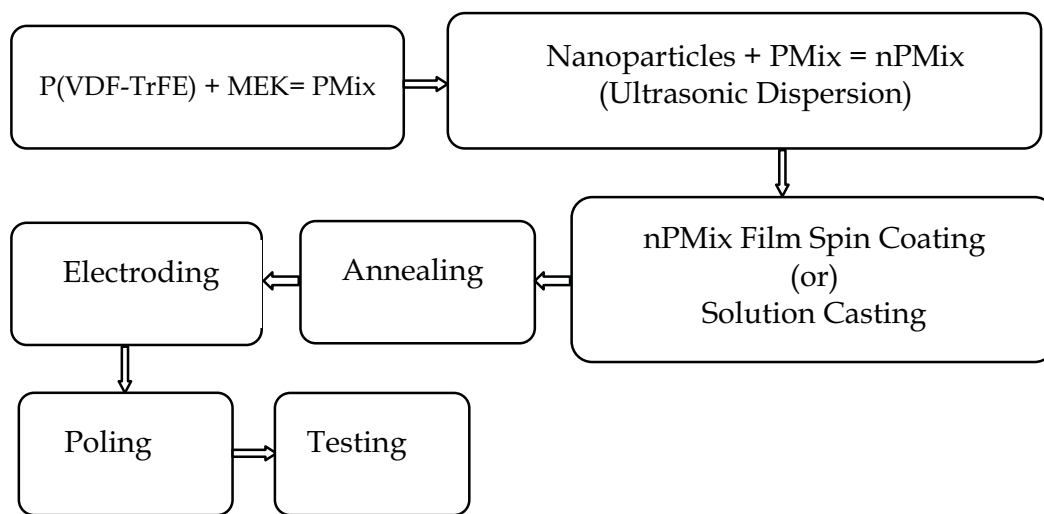

Fig. 8. A Flow chart for fabrication of thin-film of composite

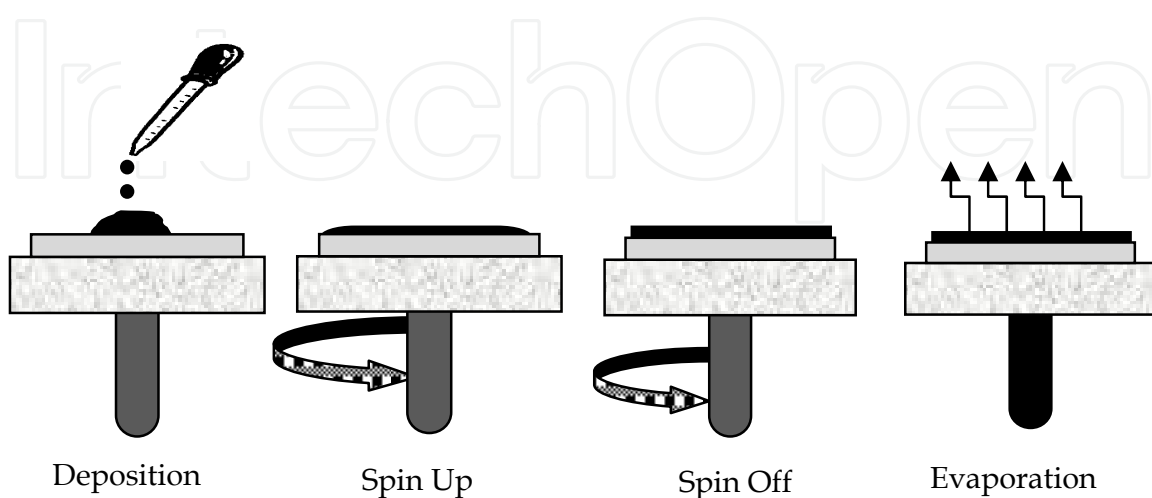

Fig. 9. Spin Coating Technique Processing Steps

## 7. Poling of composites

To develop pyroelectric-/electro-activities, these composites are initially subjected to an external electric field. This process is called poling. The composites can be poled (i.e., polarized) by following methods namely: thermal, electric field, corona, electronic-beam poling; plasma, and hysteresis poling (Sessler, 1994).

In thermal poling a high DC step voltage of appropriate magnitude (1-10 MV/m) is applied at an elevated temperature for an extended period of time (from a few minutes to a few days) in vacuum or silicon oil bath. The sample is then cooled down to room temperature with the polarizing DC voltage on. This way, polar alignment is stabilized. The ceramic content shall be polarized provided the applied field is greater than the coercive field of the ceramic. In some cases for poling polymers, film is stretched while the corona discharge is on. This produces uniform orientation of domains and large piezoelectric coefficients (Sessler, 1994; Das-Gupta and Doughty, 1986; Kaure et al., 1991).

In field poling, an applied field is up to 10 MV/m and poling time is usually a few seconds. After poling, the sample is shorted to remove the charges.

In corona poling (Sessler, 1994), a non-metalized face of the sample is exposed to Corona discharge between a needle (Dias and Das-Gupta, 1996), biased at 10 to 15kV, and the electroded rear face of the sample is grounded. This way one side electroded sample is charged on the unelectroded face by means of a corona current produced at a corona point (Dias and Das-Gupta, 1996; Sessler, 1994). The samples are exposed for about a few seconds to minutes at room temperature or elevated temperature. The charges deposited by corona discharge set up a field in the sample and cause alignment of the dipoles to occur.

In electron beam poling, the field generated by injected electrons polarizes the sample. One side of the sample is electroded only. A non-metalized sample is irradiated with electrons. The injected electrons are trapped, after drift, in a thin layer. Thus, electric field between the electrons and their counter charges on the rear electrodes polarizes the sample.

In hysteresis poling, an electric field of a low frequency (0.1Hz) is applied to the sample at room temperature.

Ploss et al., 2000, Ploss et al., 2001 and Chan et al., 1999 have demonstrated a poling technique for ferroelectric composites of ceramic particles like lead titanate or lead zirconate titanate in poly (vinylidene fluoride-trifluoride) or poly (Vinylidene fluoride-trifluoroethylene). A copolymer, in the matrix can be poled parallel or in anti-parallel directions. When the matrix and inclusions are poled in opposite directions, the pyroelectric response will be reduced, but the piezoelectric response will be reinforced. On the other hand, if two phases are polarized in parallel, the pyroelectric response reinforces while piezoelectric activity partially cancels, thereby reducing vibration-induced electrical noise in pyroelectric sensors. The composite films cited above, a dc field of the order of 50 MV/m for 1 hour at 115°C (above Curie temperature of the polymer) is used to polarize the ceramic phase. When cooling to room temperature, the electric field is kept on, so that a polymer phase is polarized in the same direction as the ceramic phase. The composite is reheated to 95°C and poled under dc field of 50MV/m for another two hours to polarize the polymer phase completely.

## 8. Properties and infrared detector performance parameters of important pyroelectric: polymer composites

### 8.1 Micro- and nano-pyroelectric polymer composites

The dielectric and pyroelectric coefficient, on TGS-PVDF composites with different proportion of TGS have been investigated (Wang et al., 1991). It was found that the variation

of dielectric and pyroelectric coefficients with temperature for composites were as reported for TGS single crystals. Furthermore, it was reported that with 50 wt% of TGS particles in the composite, the figure of merit is the largest. It was also shown that  $D^*$  value of detectors made out of TGS composite reaches up to  $(5-7) \times 10^7 \text{ cm Hz}^{1/2} \text{ W}^{-1}$ . Wang et al., (Wang et al., 1993) investigated the 45 micron to 75 micron TGS particles of different volume fraction (up to 80 vol. fraction), dispersed in organic solvent for the preparation of films using solution-casting technique. It was observed that the pyroelectric coefficient increased to  $90 \mu\text{C}/\text{m}^2\text{K}$  and figure of merit ( $p/\epsilon$ ) to 3.3 with 80 % volume of TGS particles. A novel technique has been used in the fabrication of ATGS-PVDF oriented film (Changshui et al., 1998). A high electric field was applied during preparation of the film. It was also reported that PVDF: ATGS (L-alanine doped TGS) that with highest field grains get oriented to b-axis when field is increased perpendicular to b-axis. With a field of 10 kV/cm, better results for dielectric constant  $\sim 10$  and pyroelectric coefficient  $\sim 30 \mu\text{C}/\text{m}^2\text{K}$  at about  $30^\circ\text{C}$  have been reported. Recently Yang et al., 2006 performed an extensive and noteworthy study on TGS: P (VDF-TrFE) composites with various volume fractions (0.05 to 0.43) of TGS embedded in P (VDF-TrFE). The pyroelectric coefficient varied from  $32 \mu\text{C}/\text{m}^2\text{K}$  to  $102 \mu\text{C}/\text{m}^2\text{K}$ . The dielectric constant increased from 9.66 to 12.27 while the dielectric loss decreased from 0.021 to 0.008. The two phases of samples were poled in same direction, in which pyroelectric coefficient reinforced while the piezoelectric contribution partially cancels out. The low piezoelectric activity in pyroelectric composite is an asset as it reduces the vibration induced noise. TGS: P (VDF-TrFE) is a good candidate for sensing element in pyroelectric infrared detecting devices.

The detailed study on the pyroelectric and piezoelectric properties of PT-P (VDF-TrFE) composites gave the maximum value of pyroelectric coefficient, with 54 % volume fraction of the particles (Chan et al., 1998). Pyroelectric coefficient and dielectric constant were  $40.7 \mu\text{C}/\text{m}^2\text{K}$  and 57.3 respectively which gives a value of 0.71 for figure-of-merit. However, maximum value of figure-of-merit (0.92) for composite having 49 % vol. fractions was obtained when only ceramic phase was poled. However, when both the phases were poled then pyroelectric coefficient and dielectric constant were  $69.2 \mu\text{C}/\text{m}^2\text{K}$  and 55 respectively which gives the value of figure-of-merit of 1.24. The pyroelectric properties of  $\text{PbTiO}_3$ -P(VDF-TrFE) 0-3 nano-composites films fabricated using with various volume fraction of ceramic of particles of about 70 nm size have been investigated by Chen et al., 1998. They could fabricate films with only up to volume fraction of 12% due to problem of agglomeration. The films were prepared by spin coating method on aluminum-coated glass. All the figure-of-merits ( $F_I$ ,  $F_V$  and  $F_D$ ) reported by them showed an increase with increase of volume fraction of lead titanate ceramic particles. The results obtained for pyroelectric properties are shown in Figure 9. It was concluded that pyroelectric coefficient of the composite with 12% volume fraction of PT was 40% higher than that of the polymer. A  $D^* = 1.2 \times 10^7 \text{ cm Hz}^{-1/2} \text{ W}^{-1}$  has been achieved in composite films of  $[(\text{Pb}_{0.8}\text{Ca}_{0.2}) \text{TiO}_3:\text{P}(\text{VDF-TrFE})]$  prepared using appropriate amount of ceramic particles having size less than 100 nm (Zhang et al., 2000). The values obtained for dielectric and pyroelectric coefficients by Zhang et al., 2001 for nano-crystalline calcium (0.11%), modified lead titanate (PCLT) are presented in Table 2.  $F_V$  and  $F_D$  exhibit maxima around 0.11 volume fraction of PCLT nanoparticles. The figure-of-merits were 35% higher than poled copolymer. A noteworthy study was performed on thin film deposited on silicon substrate, consisting of 12 vol. % of nano-sized lanthanum and calcium modified lead titanate embedded in P (VDF-TrFE) 70/30 matrix to

form pyroelectric sensors with three different configurations. The maximum specific detectivity ( $D^*$ )  $1.3 \times 10^7 \text{ cm Hz}^{1/2}/\text{W}$  (at 1 kHz),  $2.11 \times 10^7 \text{ cm Hz}^{1/2}/\text{W}$  (at about 300Hz) and  $2.8 \times 10^7 \text{ cm Hz}^{1/2}/\text{W}$  (between 5 and 100Hz) respectively, was reported. Authors suggested that sensors fabricated with PCLT/P (VDF-TrFE) nano-composites have potential to be used in silicon based pyroelectric sensors (Zhang et al., 1999). The characteristics of  $8 \times 1$  array fabricated using modified lead titanate powder prepared by sol-gel method dispersed in polymer, P (VDF-TrFE) were studied by Zhang et al. 1999, Loiacono and Dougherty, 1978. The amount of powder used was 12 vol. %. The film of thickness of  $12 \mu\text{m}$  was prepared by spin-coating method on glass substrate. After poling the film, it was removed from the glass substrate and bonded to a silicon chip with readout electronic circuitry to form  $8 \times 1$  integrated linear arrays. The variation of specific detectivity ( $D^*$ ) with frequency is shown in Figure 9. The maximum value of  $D^*$  obtained in this array was  $1.45 \times 10^7 \text{ cm Hz}^{1/2}/\text{W}$ . However this value is 1-2 orders lower than found in single crystalline materials. Lead magnesium niobate-lead titanate (abbreviated PMN-PT) with 30% mol PT: P (VDF-TrFE) 70/30 composite has been investigated by Lam and Chan, 2005. With increasing KTN content, the ferroelectric, piezoelectric and pyroelectric properties of the composite improve comparative to the PMNPT/P(VDF-TrFE) biphasic composite with the same PMNPT volume fraction due to increasing poling degree of the PMNPT particles (Xia et al. 2008). Hilczer et al., 2002 have performed an important study of pyroelectric and dielectric dispersion response of P ( $Z_{0.5}T_{0.5}$ )O<sub>3</sub>-P (VDF<sub>0.5</sub>-TrFE<sub>0.5</sub>) nanocomposite film samples of 100-200 $\mu\text{m}$  thick having powder of P( $Z_{0.5}T_{0.5}$ )O<sub>3</sub> crystallite size  $\sim 30\text{nm}$ . Composites (PZT<sub>0.32</sub>PVDF<sub>0.68</sub>, PZT<sub>0.24</sub>[P(VDF<sub>0.5</sub>-TrFE<sub>0.5</sub>)<sub>0.76</sub>]) displayed an excellent pyroelectricity. It was observed by dielectric dispersion studies that the role of polymer heterogeneity at crystalline level is important in PZT-PVDF nanocomposites in the temperature range from 315K to 395K. In PZT- P (VDF<sub>0.5</sub>-TrFE<sub>0.5</sub>) composites, this becomes important above  $\sim 350\text{K}$  due to effect of the ferroelectric-paraelectric phase transition. It was reported that the variation of dielectric constant is temperature and frequency independent between  $\sim 275\text{K}$  to  $310\text{K}$ . Due to excellent figure-of-merits values for these composite, it was proposed that the sensor operating temperature could be in the range of 290K to 310K. Recently authors of this article performed an extensive study on P (VDF-TrFE): modified PZT composites films prepared by solution casting technique and also with spin-coating method. The results are presented in Table 2 (Batra et al., 2003). Recently thick films of 0-3 composites of lead zirconate titanate ceramic and polyvinylidene - trifluoroethylene copolymers have been produced by spin-coating on gold coated silicon wafer (Dietze et al., 2007). A pyroelectric coefficient of  $92 \mu\text{C}/\text{m}^2\text{K}$  has been measured for composites with 20 % volume ceramic. For the composites with 10 and 20 vol. % ceramic, voltage and current figures-of-merit are higher than PZT thick films. A most important disadvantage with the use of PVDF as sensor material is the requirement of a high poling field. PVDF and lithium tantalate (LT) composites are investigated for their pyroelectric and dielectric properties as infrared detector. The choice of LT was decided by the fact that LT has much lower poling field requirement and larger pyroelectric coefficient, with comparable dielectric constant to PVDF. Studies show that LT/PVDF nanocomposite can prove to be a better alternative to both single crystal LiTaO<sub>3</sub> and pure PVDF for pyroelectric sensor applications. (Satapathy et al., 2009)

Lithium tantalite [(LiTaO<sub>3</sub>), LT] ceramic particles have been incorporated into a polyvinylidene fluoride-trifluoroethylene [P (VDF-TrFE) 70/30 mol%] copolymer matrix to



form composite films. The films were prepared using solvent casting method with the LT powder homogeneously dispersed in the P (VDF-TrFE) copolymer matrix with various volume fractions. Electrical properties such as the dielectric constant, dielectric loss, and pyroelectric coefficient have been measured as a function of temperature as well as frequency. In addition, materials' figures-of-merit have also been calculated to assess their use in infrared detectors. The results show that the fabricated lithium tantalite: polyvinylidene fluoride-trifluoroethylene composite films have a good potential for uncooled infrared sensor applications operating at moderate temperatures (Batra et al., 2009).

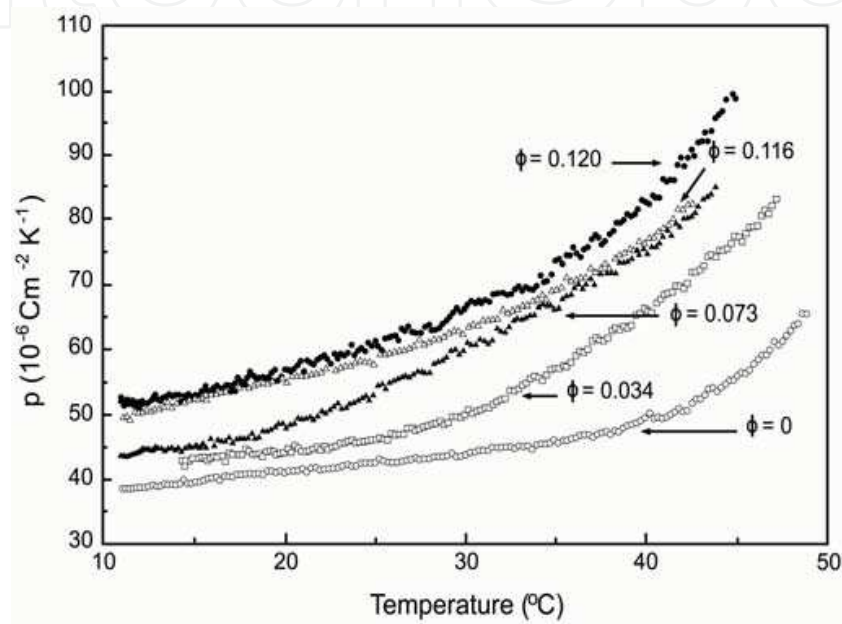

Fig. 9. Pyroelectric coefficients of the composite films with various volume fraction of ceramic ( $\phi$ ) lead titanate as function of temperature (Chen et al., 1998).

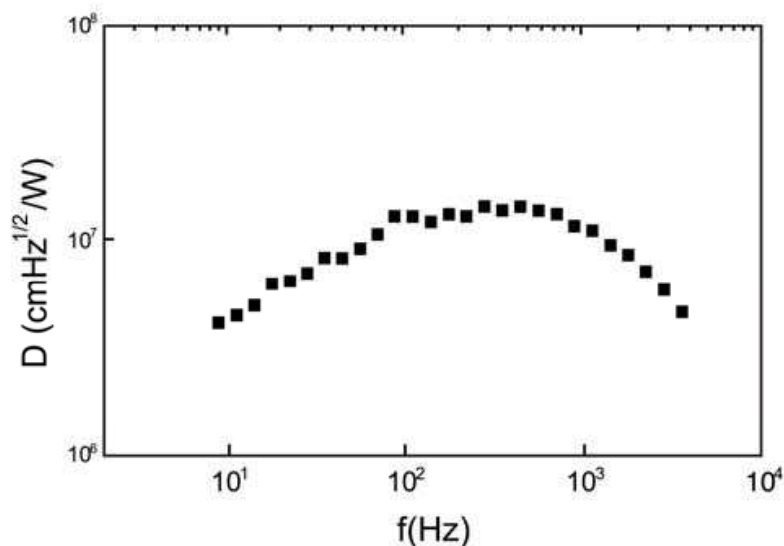

Fig. 10. Specific detectivity of an element in an array (Zhang et al., 1999).

Sample	$F_i = p$ ( $\mu\text{C m}^{-2}\text{K}^{-1}$ )	$\epsilon'$	$F_v = p/\epsilon'$ ( $\mu\text{C m}^{-2}\text{K}^{-1}$ )	References
P(VDF-TrFE) (Commercial Sample)	34	16.1	2.1	Chan et al., 1998
PVDF (Commercial Sample)	38	5.3	5.7	Dias and Das- Gupta, 1996
P(VDF-TrFE)70/30 (Commercial Sample)	41.2	11.0	3.7	Dias and Das- Gupta, 1996
PT(vol 62%):PVDF Used dispersoids ceramic grains and pressed into thin films of 30-70 $\mu\text{m}$ range	130	54	2.4	Dias and Das- Gupta, 1996
PLZT(26..27wt%) :P(VDF-TrFE) Used dispersoids ceramic grains and Solution Casting method for thick films of range 20 $\mu\text{m}$	16.7	25	0.66	Guggilla, 2007
PLZT (12..33wt%) : nano P(VDF-TrFE) Used dispersoids ceramic grains and Solution Casting method for thick films of range 20 $\mu\text{m}$	9.0	14.12	0.64	Guggilla, 2007
PZT (vol. 50% ): PVDF	90	10	0.11	Dias and Das- Gupta, 1996
PZT (vol.50%): P(VDF- TrFE)	39	118	0.33	Lang and Das- Gupta, 2000
TGS:PVDF	30	10.0	3.0	Kobune, 1997
BT: PVC	0.08	3.7	0.02	Dias and Das- Gupta, 1996
PLZT (10.57wt%) :P(VDF-TrFE) Used dispersoids ceramic grains and Solution Casting method for thick films of range 30 $\mu\text{m}$	11.07	33.15	.33	Guggilla, 2007

Table 2. Material characteristics and Figure-of-Merits of 0-3 Composites

### 8.2 Metal-nanoparticles reinforced pyroelectric polymer composites

As both Lithium tantalite ((LiTaO<sub>3</sub>), LT) and polyvinylidene fluoride-trifluoroethylene (P (VDF-TrFE)) have excellent ferroelectric and pyroelectric properties, LT ceramic particles have been incorporated into P (VDF-TrFE) copolymer matrix with 70/30 mol% to form 0-3 composite films. Due to the low relative permittivity of LT the pyro-activity and performance of infrared detector will be increased [4]. However, pyroelectric particles in the 0-3 composites cannot be fully poled due to the screening effect of the polymer matrix i.e. important properties of the composite are reduced. Sakamoto et al [5] indicated that PZT/PU composite doped with graphite particles improved the poling behavior of PZT phase and intern improved pyroelectric and piezoelectric properties. Oltean et al [6] studied some electrical properties of metallic iron reinforced polymeric composite materials subjected to stress state: electric field, and temperature variation and mechanical load. In order to increase the conductivity of these LT: P (VDF-TrFE) samples it is proposed to embed the silver nano particles into this system.

Films of LT: P (VDF-TrFE) composites with 2% volume fraction of LT powder and with Ag nanoparticles particles have been fabricated using 'solution cast' method. This technique is a very useful and inexpensive technique for manufacturing composite pyroelectric sensor because composite films can be fabricated with less energy, time and effort as compared to ceramic and single crystal fabrication. To assess their use as pyroelectric infrared detectors, various figures-of-merit of composite films have been calculated and compared with pure P (VDF-TrFE) film fabricated with the described techniques in the previous section.

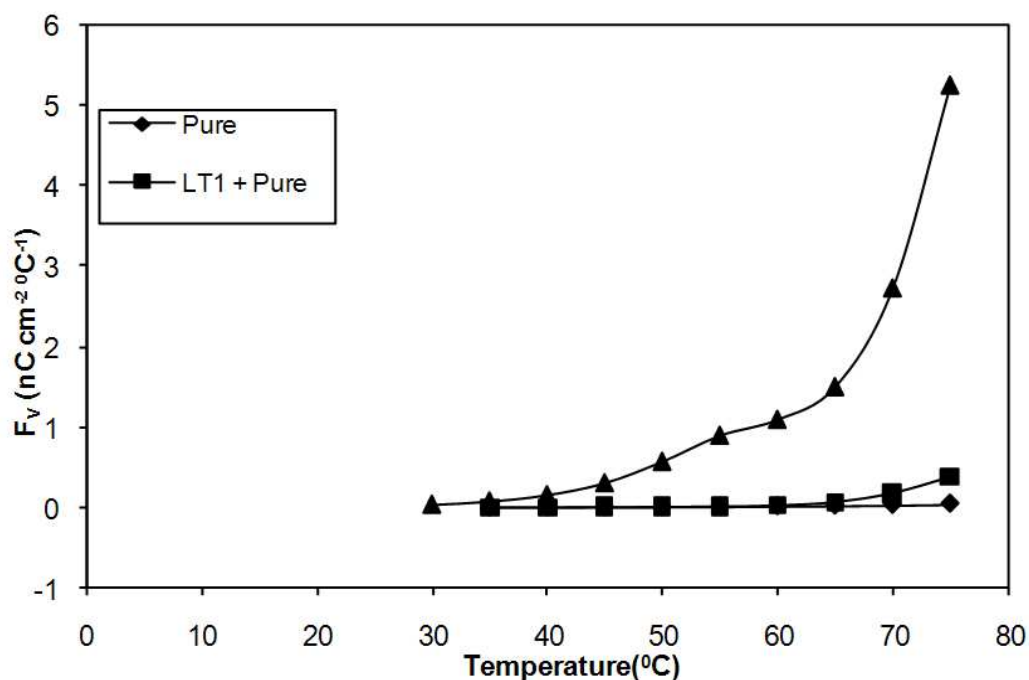

Fig. 11. Temperature Dependence of Figure-of-Merit,  $F_v$ , for Pure PVTF, PLT1 and PLT1Ag films

The pyroelectric performance figures-of-merit, the voltage responsivity increases with the volume fraction of LT and with addition of silver nanoparticles in the polymer matrix as shown in figure 11. Preliminary data on Figures-of-Merit of composite films are higher than P (VDF-TrFE) film poled under similar conditions. Based on the preliminary results

obtained, LT: P (VDF-TrFE) and LT: P (VDF-TrFE) +Ag films are attractive for use in infrared sensing elements especially where low level applications and curved surface detectors are needed.

## 9. Advantages of micro- and nano-pyroelectric composites

Some of the advantages of the Micro and nano-pyroelectric composites are greater tensile and flexural strength for the same dimension of polymer part, reduced weight for the same performance increased dimensional stability, improved gas barrier properties for the same film thickness and higher chemical resistance.

## 10. Applications of pyroelectric detectors

These uncooled pyroelectric infrared detectors are used in many applications and few of them are: Air Quality Monitor; Atmospheric Temperature Measurement; Earth Position Sensor; Earth Resources; Engine Analysis; Fire Alarm; Gas Analyzer; Glass Processing; Horizon Sensor; Infrared Detection; Infrared Spectrometer; Interferometer; Interplanetary Probe; Intrusion Detector; Laser Detection; Laser Power Control; Liquid Fuel Analysis; Meteorology; Plasma Analysis; Plastic Processing; Pollution Detection; Position Sensor; Radiometer; Reflectance Measurements; Remote Sensing; Sky Radiance; Solar Cell Studies; Human Sensors; Forest Fire Detection; Pyroelectric Vidicons; Ear Thermometer; Terahertz Detection, Biomedical Imaging; Satellite-Based IR Detection at 90°K; and Optical Wave Guide Studies; X-ray Detector; Microwave Detector; facial recognition; traffic control; vision testing; law enforcement and border patrol. Recent applications are their use in Waste Energy Harvesting for Micro-electric Generators.

## 11. Conclusions

Composites of polymers blended with ferroelectric ceramics have been well studied; design, processing and characterization (from viewpoint of their applications). Ferroelectric ceramic: polymer composites with 0-3 connectivity pattern owe their popularity to easy fabrication procedure that allows for mass production at a relatively low cost. Special reference has been made to composites made with modified lead titanate and lead zirconate titanate. These ceramics have relatively high pyroelectric properties, which gives composites substantial advantage with additional strength and flexibility of the polymer. One additional advantage of this class of ceramic-polymer composite is that when the ceramic and polymer (P (VDF-TrFE)) are poled in the same direction, the pyroelectricity of two phases reinforces while their piezoelectricity partially cancels. It minimizes the micro-phony effect arising from vibration-induced electrical noise. It is evident that higher current responsively ( $F_i$ ) and detectivity ( $F_D$ ) figure-of-merit can be obtained in composite materials fabricated with modified PT/PZT electro-ceramic and co-polymer (P (VDF-TrFE)) in right proportion.

However, only fabrication of detector with these composites shall prove their worthiness in real world. The note-worthy results have been reported by Zhang et al., 2000; a maximum value of  $D^* 1.45 \times 10^7 \text{ cm Hz}^{-1/2} \text{ W}^{-1}$  at 280Hz. for an 8x1 integrated linear pyroelectric array using PCLT/P(VDF-TrFE) composite. The composite detectors are useful for low-level applications. These detectors can be used and most importantly, where parameters like

flexibility, high strength, and large area of the infrared detector are required, e.g. cavity-shaped detector.

According to Dias and Das-Gupta, 1996, the composites however have the advantage of being easier to polarize in thicker self-supporting samples, preventing thus the need for a substrate. It can be concluded that there is a strong potential of 0-3 composites use in for low-level applications, including integration with semiconductor processing. Other technique of enhancing the pyroelectric performance such as using bimorph structure (Alexe and Pintilie, 1995) for composites can give higher voltage responsivity. However, the pyroelectric elements used in general have to be thin for the reasons of low thermal mass (and hence the high  $\Delta T$  change), most papers included in the current discussions have not been the basis of such selection or requirements. The aim of this chapter has been to overview the advantages of making composites and to study the gains in the pyroelectric figures of merit or the detectivity of the sensing elements. By having such guideline studies the further advances in designing and fabrication of composite sensing elements of desirable thickness or dimensions can be made as the future composite fabrication goals.

## 12. Acknowledgements

Authors gratefully acknowledge the partial support of the present work by NSF HBCU RISE project # 0927644. Special thanks to Drs. M. E. Edwards, R. B. Lal, M. D. Aggarwal for keen interest in our work.

## 13. References

- Abdullah, M. J., and Das-Gupta, D. K., (1988). *Ferroelectrics*, 87 312
- Abdullah, M. J., (1989) A Study of Electro-active Properties of Polymer/ceramic Composites, University of Wales - Si ECS (Bangor)
- Abdullah, M. J., and Das-Gupta, D. K., (1990). *IEEE Trans. Electr. Insur.*, Vol. 25(3) 605.
- Aggarwal, M. D., Batra, A. K., Guggilla, P., Edwards, M. E., Penn, B. G., and Currie, J. R. (2010). Pyroelectric Materials for Uncooled Infrared Detectors: Processing, Properties and Applications. *NASA Technical Memorandum*, 216373 1-71
- Alexe M. and Pintilie, L. (1995). Analysis of the pyroelectric bimorph as radiation detector, *Infrared Physics & Technology*, 1 pp (949-954)
- Batra, A. K., Aggarwal, M. D., Lal, R. B. (2003). Growth and characterization of doped DTGS crystals for infrared sensing devices. *Materials Letters* 57 pp (3943-3948)
- Batra, A. K., Aggarwal, M. D., Edwards, M. and Bhalla, A. S. (2008). Present Status of Polymer: Ceramic Composites for Pyroelectric Infrared Detectors. *Ferroelectrics*, 366 84-121
- Batra, A. K., Corda, J., Guggilla, P., Aggarwal, M. D., Edwards, M. E. (2009). Electrical properties of Silver Nanoparticles Reinforced LiTaO<sub>3</sub>:P(VDF-TrFE) Composite Films. *SPIE Proceedings Vol. 7419; Infrared Systems and Photoelectronic Technology IV*, pp(721313-2-721313-9), San Francisco, CA August 2009
- Dietze, M., Krause, J., Solterbeck, C. H., and Es-Souni, M. (2007) Thick film polymer-ceramic composites for pyroelectric applications. *J. Appl. Physics* 101 (054113-1-054113-7)
- Bauer, S., and Ploss, B. (1991). *Sensor and Actuator A* (25-27) 417

- Chan, H. L. W., Chan, W. K., Zhang, Y., and Choy, C. L. (1998). Pyroelectric and piezoelectric properties of lead titanate/polyvinylidene fluoride-trifluoroethylene 0-3 composites. *IEEE Trans. Dielec. and Elec Ins.*, 5(4) pp(505-512)
- Chan, H. L. W., Ng, P. K. L., and Choy, C. L. (1999). *Appl. Phys. Lett.*, 74(20) 3029
- Chang, J., Batra, A. K., and Lal, R.B. (1996). Growth and properties of urea-doped triglycine sulfate (UrTGS) crystals. *Journal of Crystal Growth* 158 pp(284-288)
- Changshui, F., Qingwu, W., and Hongsheng, Z. (1998). Preparation and Pyroelectric properties of oriented composite ATGS-PVDF film. *J. Korean Phys. Soc.*, 32 pp(S1843-S1845)
- Chen, Y., Chan, H. L. W., and Choy, C. L. (1998). Pyroelectric properties of PbTiO<sub>3</sub>/P(VDF-TrFE) 0-3 nano-composite films. *Thin Solid Films* 323 pp(270-274)
- Das-Gupta, D. K., Doughty, K. J., (1986). *Appl. Phys. Lett.*, 27 4601
- Dias, C. J., and Das-Gupta, D. K., (1996). *IEEE Trans. Die. Elect. Ins.* 3(5) 706 and references therein
- Dietze, M., Krause, J., Sollerbeck, C. H., Es-Souni, M. (2007). Thick film polymer-ceramic composites for pyroelectric applications. *JAP* (101) pp (054113-1-054113-7)
- Dieguez, E., Plaza, J. L., Aggarwal, M. D., Batra, A. K. (2010). Czochralski Growth of Photo-refractive Crystals In: *Handbook of Crystal Growth*, Dhanaraj, G.; Byrappa, K.; Prasad, V.; Dudley, M., pp (559-598) Springer, 978-3-540-74182-4, USA
- F. Kochary, M. D. Aggarwal, A. K. Batra, R. Hawrami, D. Lianos, A. Burger: Growth and electrical characterization of the lead magnesium niobate-lead titanate (PMN-PT) single crystals for piezoelectric devices. *J. Mater Sci: Mater Electron.*, 19 (2008)1058-1063
- Guggilla, P., Batra, A. K., Currie, J. R., Aggarwal, M. D., Lal, R. B. (2006). Pyroelectric Ceramics for Infrared Detection Applications. *Materials Letters* 60 pp (1937-1942)
- Guggilla, P., (2007) Studies on pyroelectric materials for infrared sensor application. Ph.D. Dissertation, Alabama A & M University, Normal, Alabama, U.S.A.
- Guggilla, P., Batra, A.K., Edwards, M. E. (2009). Electrical Characterization of LiTaO<sub>3</sub>: P (VDF-TrFE) Composites. *J. Materials Science* 44, pp (5469-5474)
- Hilczer, B., Kulek, J., Markiewicz, E. and Kosec, M. (2002). Dielectric relaxation in ferroelectric PZT-PVDF nanocomposites. *Journal of Non-Crystalline Solids*, 5, pp (167-173)
- Kaure, T., Nath, R., and Perlman, M. M. (1991). *J. Phys. D: Applied Physics*, 24 1848
- Kobune, M., Mineshige, A., Fujii, S., and Maeda, Y. (1997). *Jpn. J. Appl. Phys.*, 36 5976
- Kohler, R., Padmini, P., Gerlach, G., Hofmana, G., Bruchhaus, R. (1998). *Int. Ferroelectrics*, 22 383
- Krakovsky, I., and Myroshnychenko, V. (2002). *J. Appl. Phys.*, 992 (11) 6743 and references therein
- Lal, R. B., and Batra, A. K., (1993). Growth and properties of triglycine (TGS) sulfate crystals Review. *Ferroelectrics* 142 pp (51-82)
- Lal, R. B., and Batra, A. K., (1996). Growth of crystals for infrared detectors and second harmonic generation devices. *Ceramic Transactions*, vol.60, American Ceramic Society, OH
- Lam, K. H., and Chan, H. L. W. *Composites Science & Technology*, 65(2005) 1107
- Lee, M. H., Guo, R., and Bhalla, A. S. (1998). Pyroelectric Sensors, *Journal of Electroceramics*, 2 pp (229-242)

- Loiacono, G. M., and Dougherty, J. P. (1978). Final Technical Report (contract no DAAK70-77-C-0098) submitted to Night Vision and Electro-optics Laboratories, Fort Belvoir, Virginia
- Mallick, P.K. (1997). Constituents In: Composites Engineering Handbook (Materials Engineering, ISBN: 978-0824793043 CRC Press, USA
- Nalwa, H. S. (1995). Ferroelectric Polymers, ed. page 598 Marcel Dekker, NY
- Newnham, R. E., Skinner, D. P., Cross, L. E. (1978). *Mat. Res. Bull.*, 13 523
- Ploss, B., Ng, W. Y., Chan, H. L., Ploss, B., and Choy, C. L. (2001). *Composite science and technology*, 61 957
- Ploss, B., Shin, F. G., Chan, H. L. W., and Choy, C. L. (2000). *Appl. Phys. Lett.*, 76(19) 2776
- R. E. Newnham, D. P. Skinner, L. E. Cross: Connectivity and piezoelectric-pyroelectric composites, *Mat. Res. Bull.*, 13 (1978) 525-536
- Satapathy, S., Gupta, P. K., and Varma, K. B. R. (2009). Enhancement of nonvolatile polarization and pyroelectric sensitivity in lithium tantalate (LT)/poly (vinylidene fluoride) (PVDF) nanocomposite. *J. Phys. D: Appl. Phys.* 42 055402 (6pp)
- Sessler, G. M. (1994). Ferroelectric Polymer and Ceramic-Polymer Composites, *Key Engn. Mat.*, vol. 92-93 249
- Sidney B. L., and Das-Gupta, D. K., (2000). *Ferroelectrics Review*, 2 pp (217-223)
- Taya, M. (2008). Introduction In: *Electronic Composites*, pp (1-19), Cambridge University Press, ISBN-13: 9780521057318, UK
- Tressler, J. F., Alkoy, S., Dogan, A., Newnham, R. E. (1999). *Composites (A)*, (30) 477
- Wang, M., Fang, C. S., and Zhuo, H. S. (1991). Study on the pyroelectric properties of TGS-PVDF composites, *Ferroelectrics* 118 pp (191-197)
- Wang, Y., Zhong, W., and Zang, (1993). P. Pyroelectric properties of ferroelectric-polymer composite, *J. App. Phys.*, 74(1) pp (512-524)
- Whatmore, R. W., and Watton. (2001) R. Pyroelectric Materials and Devices Infrared Detectors and Emitters: Materials and Devices. *Kluwer Academic Publishers*,
- Xia, Y. F., Ming, Z. D., Wei, D. Z., Yuan, C. Z., and Lin, J. S. (2008). The influence of ferroelectric KTN particles on electric properties of 0-3 ferroelectric composites. *J. Phys. D: Appl. Phys.* 41 (2008) 055408 (5pp)
- Yamada, T., Ueda, T., and Kitayama, T. (1982). *J. Phys. Phys.* 53 (4) 4328
- Yamazaki, H. and Tayama, T. K. (1981). *Ferroelectrics*, 33 147
- Yang, Y., Chan, H. L. W., and Choy, C. L. (2006). Properties of triglycine sulfate/poly (vinylidene fluoride-trifluoroethylene) 0-3 composites, *J. Mat. Sci.*, 41 pp (251-258)
- Zhang, Q. Q, Chan, H. L. W., and Choy, C. L. (1999). Dielectric and pyroelectric properties of P (VDF-TrFE) and PCLT-P (VDF-TrFE) 0-3 nanocomposite films, *Composites Part a: Applied Science and Manufacturing* 30 pp (163-167)
- Zhang, Q.Q, Chan, H. L. W., Ploss, B., Zhou, Q. F., and Choy, C. L., (1999). *J. Non. Cryst. Solids*, 254 pp (118-125)
- Zhang, Q. Q, Chan, H. L. W., Ploss, B., and Choy, C. L. (2001). PCLT/P(VDF-TrFE) nanocomposite pyroelectric sensors, *IEEE Trans. Ultra., Ferro., and Freq. Cont.*, 48(1) pp(154-160)
- Zhang, Q.Q, Ploss, B., Chan, H. L. W., and Choy, C. L. (2000). *Sensors and Actuators A*, 86 216
- Zhang, Q. Q, Ploss, B. Chan, H. L. W., and Choy, C. L. (2000). Integrated pyroelectric arrays based on PCLT/P (VDF-TrFE) composite, *Sensors and Actuators A* 86 pp (216-219)
- Zook, J. D., and Liu, S. T. (1976). *Ferroelectrics*. 11 371

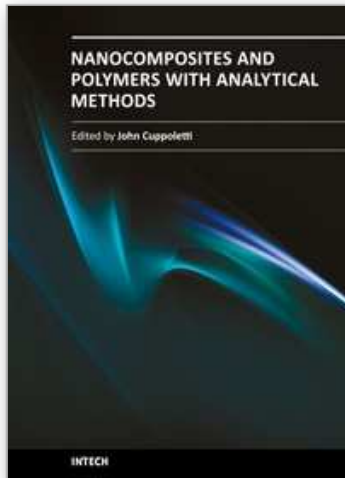

## **Nanocomposites and Polymers with Analytical Methods**

Edited by Dr. John Cuppoletti

ISBN 978-953-307-352-1

Hard cover, 404 pages

**Publisher** InTech

**Published online** 09, August, 2011

**Published in print edition** August, 2011

This book contains 16 chapters. In the first part, there are 8 chapters describing new materials and analytic methods. These materials include chapters on gold nanoparticles and Sol-Gel metal oxides, nanocomposites with carbon nanotubes, methods of evaluation by depth sensing, and other methods. The second part contains 3 chapters featuring new materials with unique properties including optical non-linearities, new materials based on pulp fibers, and the properties of nano-filled polymers. The last part contains 5 chapters with applications of new materials for medical devices, anodes for lithium batteries, electroceramics, phase change materials and matrix active nanoparticles.

### **How to reference**

In order to correctly reference this scholarly work, feel free to copy and paste the following:

Padmaja Guggilla and Ashok K. Batra (2011). Novel Electroceramic: Polymer Composites - Preparation, Properties and Applications, Nanocomposites and Polymers with Analytical Methods, Dr. John Cuppoletti (Ed.), ISBN: 978-953-307-352-1, InTech, Available from: <http://www.intechopen.com/books/nanocomposites-and-polymers-with-analytical-methods/novel-electroceramic-polymer-composites-preparation-properties-and-applications>

**INTECH**  
open science | open minds

### **InTech Europe**

University Campus STeP Ri  
Slavka Krautzeka 83/A  
51000 Rijeka, Croatia  
Phone: +385 (51) 770 447  
Fax: +385 (51) 686 166  
[www.intechopen.com](http://www.intechopen.com)

### **InTech China**

Unit 405, Office Block, Hotel Equatorial Shanghai  
No.65, Yan An Road (West), Shanghai, 200040, China  
中国上海市延安西路65号上海国际贵都大饭店办公楼405单元  
Phone: +86-21-62489820  
Fax: +86-21-62489821



© 2011 The Author(s). Licensee IntechOpen. This chapter is distributed under the terms of the [Creative Commons Attribution-NonCommercial-ShareAlike-3.0 License](#), which permits use, distribution and reproduction for non-commercial purposes, provided the original is properly cited and derivative works building on this content are distributed under the same license.

IntechOpen

IntechOpen