

# We are IntechOpen, the world's leading publisher of Open Access books Built by scientists, for scientists

**4,800**

Open access books available

**122,000**

International authors and editors

**135M**

Downloads

Our authors are among the

**154**

Countries delivered to

**TOP 1%**

most cited scientists

**12.2%**

Contributors from top 500 universities



**WEB OF SCIENCE™**

Selection of our books indexed in the Book Citation Index  
in Web of Science™ Core Collection (BKCI)

Interested in publishing with us?  
Contact [book.department@intechopen.com](mailto:book.department@intechopen.com)

Numbers displayed above are based on latest data collected.

For more information visit [www.intechopen.com](http://www.intechopen.com)



# Voltage Fluctuations Produced by the Fixed-Speed Wind Turbines during Continuous Operation - European Perspective

Carlos López and Jorge Blanes  
*Universidad de León*  
*Spain*

## 1. Introduction

Since wind energy begun to have importance in some countries, several authors from different countries have presented in international publications the influence of such injection of energy over the power quality in the electrical power system. Since the concept of wind turbine employed at that time was mostly the asynchronous generator directly connected to the grid, the problems originated by the fluctuations in the power output of these generators (and therefore in the voltage, responsible of the *flicker* phenomenon) began to be a matter of concern for the scientific community.

In Europe the Agencies and Universities in the Northern countries have pioneered the study of power quality of wind turbines and the problems of their integration into the grid. The collaboration between these agencies and universities has enabled their joint participation in the project funded by the Fourth Framework Program of the European Union "European Wind Turbine Testing Procedure Developments", completed in 2001 (Sorensen et al., 1999). This project provided cover for the then emerging standard IEC 61400-21.

## 2. Mechanical power fluctuations

It is well known that a wind turbine produces, in general, a variable mechanical power, eventually resulting in a delivered electrical power which is also variable, causing voltage variations in the network. The variations of the wind speed (mainly of stochastic nature) together with the aerodynamic effects of the turbine, of periodic regular basis, are the main responsible for this behavior.

The wind speed is usually characterized by its average value at intervals of 10 minutes (estimated by means of the *Weibull*<sup>1</sup> *distribution*), that overlaps the variable component or "turbulent", heavily dependent on the exact location of the turbine. The frequency spectrum of the resulting power of the wind on the surface swept by the rotor reveals (Pierik et al., 2004) that, for diameters larger than 20 m, the components above 0.3 Hz are practically non-

---

<sup>1</sup> The function of the Weibull distribution is:  $F(V_0) = P(V_0 < V) = e^{-\left(\frac{V_0}{C}\right)^k}$ , being C an scaling factor and, usually,  $1,5 < k < 3$ . For the value  $k = 2$  it is known as Rayleigh distribution.

existent. This effect added to the great inertia of the rotor makes impossible to follow the rapid changes in the wind speed (Papathanassiou & Papadopoulos, 1999)].

It is unanimously accepted that the causes of the periodic fluctuations of the power are the stratification of the wind speed (wind gradient) and, to a greater extent, the *tower shadow* effect (Thiringer, 1996), both illustrated in figure 1. The first of these phenomena is due to the fact that the speed of the incident wind on the turbine increases with the height (Thiringer & Dahlberg, 2001). The growth law depends on factors such as the roughness of the terrain, the type of atmosphere, etc. This means that, even assuming a constant wind speed, the torque transmitted by each blade on different parts of its pathway is not constant. Instead, it has a periodic component of frequency  $3p$ , being  $p$  the frequency of the rotor rotation.

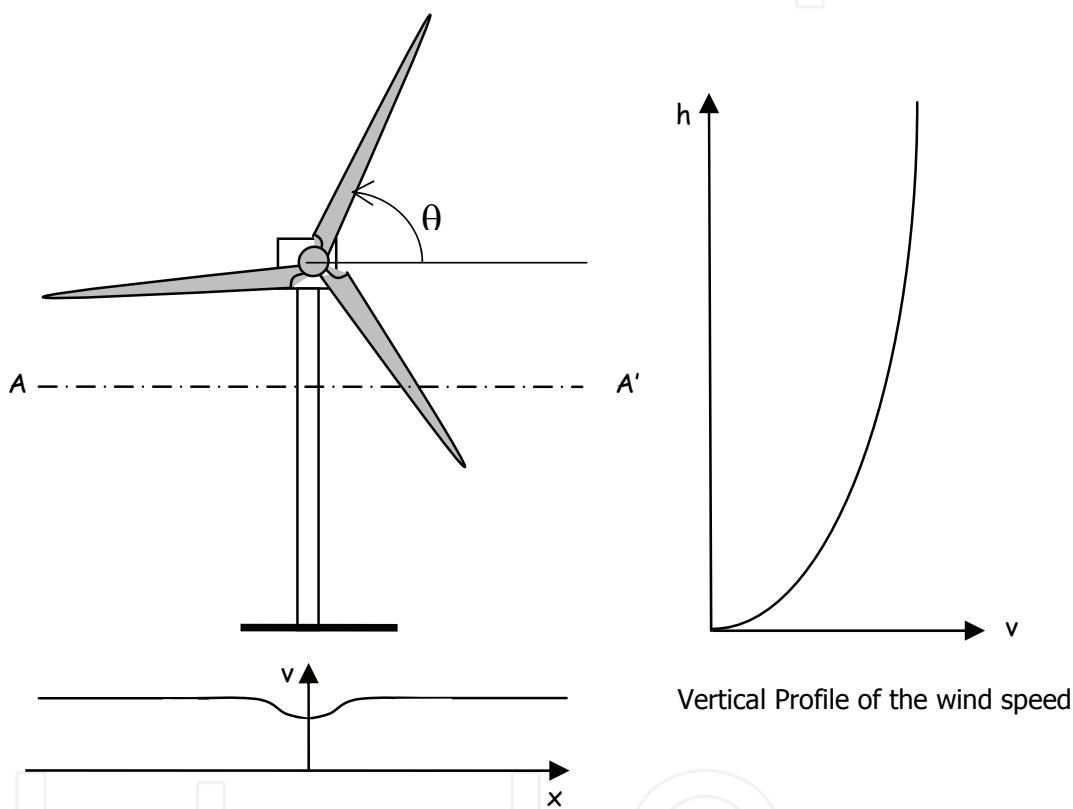

Fig. 1. Effect *shadow of tower* and stratification of the wind speed with the height

The *tower shadow* effect is caused by the local wind speed decrease in the vicinity of the tower, which causes the decline of the instantaneous torque each time one of the blades passes through its lowest position. The frequency of torque oscillations induced by this effect is, again,  $3p$ . Each time one of the blades is faced with the tower (minimum torque), none of them is at the highest position (maximum torque), resulting in an addition of both effects (Larson, 1996).

Wind turbines equipped with variable speed generators can mitigate, at least in part, the variations in the mechanical power by increasing or decreasing its stored kinetic energy. On the other side, turbines equipped with fixed speed generators deliver the fluctuations of the mechanical power to the power system, instantly and barely mitigated. Therefore, this type

of turbine, equipped with an asynchronous generator and usually known as the “Danish concept”, is the potential source of voltage fluctuations causing flicker. In the course of this paper we refer to this type of wind turbine.

In virtually all the studies published in this field (Papathanassiou & Papadopoulos, 1999; Thiringer & Dahlberg, 2001), the maximum amplitude of the periodic power fluctuations produced by the asynchronous fixed speed is quantified as 20% of the average power, and takes place when the turbine operates with a high wind speed. When this speed is low, the oscillations are lower in relative value. The frequency of the oscillations of the three blade fixed-speed commercial turbines varies between 0.7 and 2.2 Hz (Takata et al. 2005). In the case of the turbine Neg Micon 52/900 the rotation speed is 22.4 r.p.m., so that the  $3p$  frequency corresponds to:

$$f_{3p} = \frac{22.4 \times 3}{60} = 1.12 \text{ Hz}$$

Figure 2 shows, as an example, the spectral analysis of the electric power supplied by a 500 kW fixed speed generator (NTK 500/41)<sup>2</sup>, located in the Risoe Campus in Roskilde (Denmark) and the wind speed cubed, which is proportional to the power of the wind.

Note the presence of  $3p$  frequency components and some of its multiples in the power generated, but not in the wind power, this implies that these components are introduced by the turbine itself.

### 3. Voltage variations

Once accepted that the electrical power output of a wind generator is not constant, the problem that arises is to calculate how these changes affect the voltage at the point of common connection (PCC) and, therefore, the flicker emitted.

#### 3.1 Theoretical analysis on the P-Q generator model

The classical way to analyze the impact of a generator (or load given the case) of a certain power, over the voltage of the grid is to represent this last by its Thevenin equivalent at the connection point and consider the active and reactive power flows between the generator and the grid (see fig. 3).

This model is considered valid for analysis of stationary voltage variations (including *flicker*) (Larson, 1996). In case of transient analysis, dynamic models should be used for the generators (Cidrás & Feijóo, 2002).

The baseline data for the calculation of the variation in supply voltage at a certain point of the network are the active and reactive power exchanged between the generator and the network (after taking into account the compensation by the capacitor), the equivalent impedance of the network at the connection point,  $\bar{Z} = R + jX$ , and the voltage  $U_0$  (which is taken as constant).

---

<sup>2</sup> Analysis carried out from time series data of ten minutes provided by the DTU, courtesy of Kurt Hansen. The sampling period is 0.028 s, which corresponds to a sampling frequency of 35.714 s<sup>-1</sup>. The series was analyzed in 1024 data windows, this is, of 28.672 seconds wide.

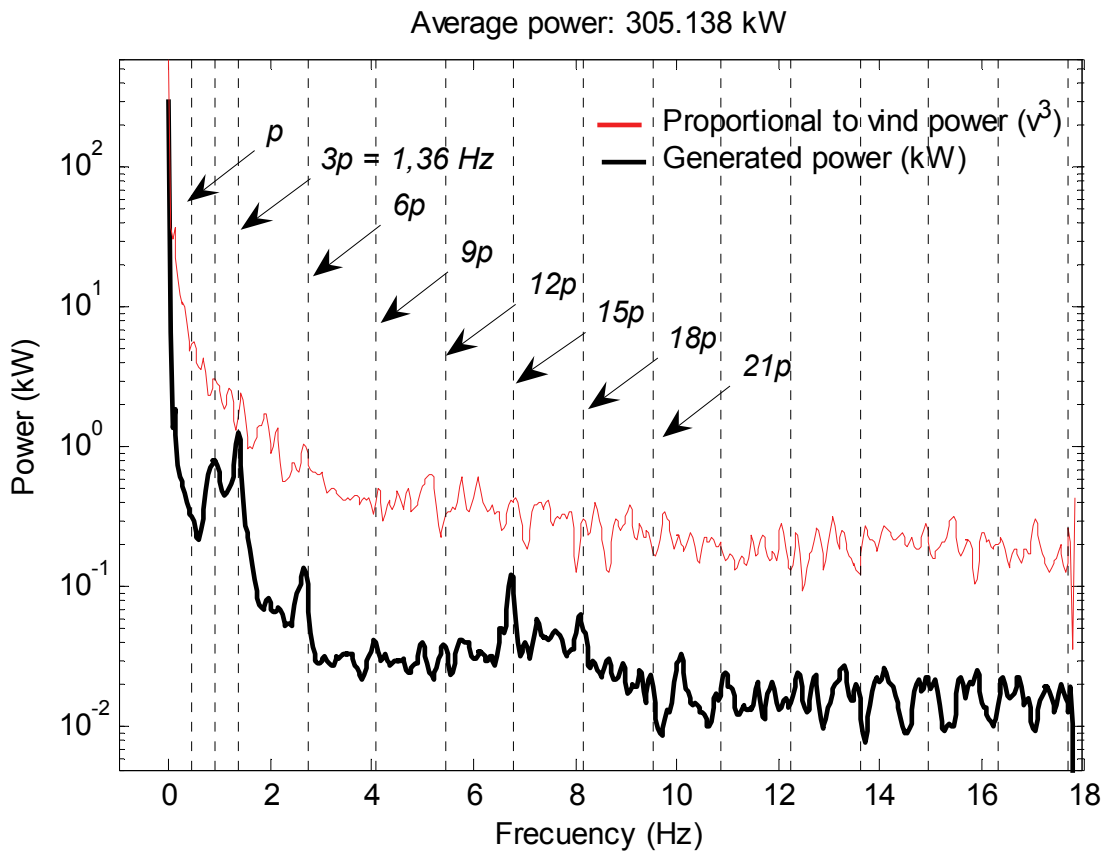

Fig. 2. Spectral analysis of the electric power supplied by a 500 kW fixed speed generator and the power of the wind.

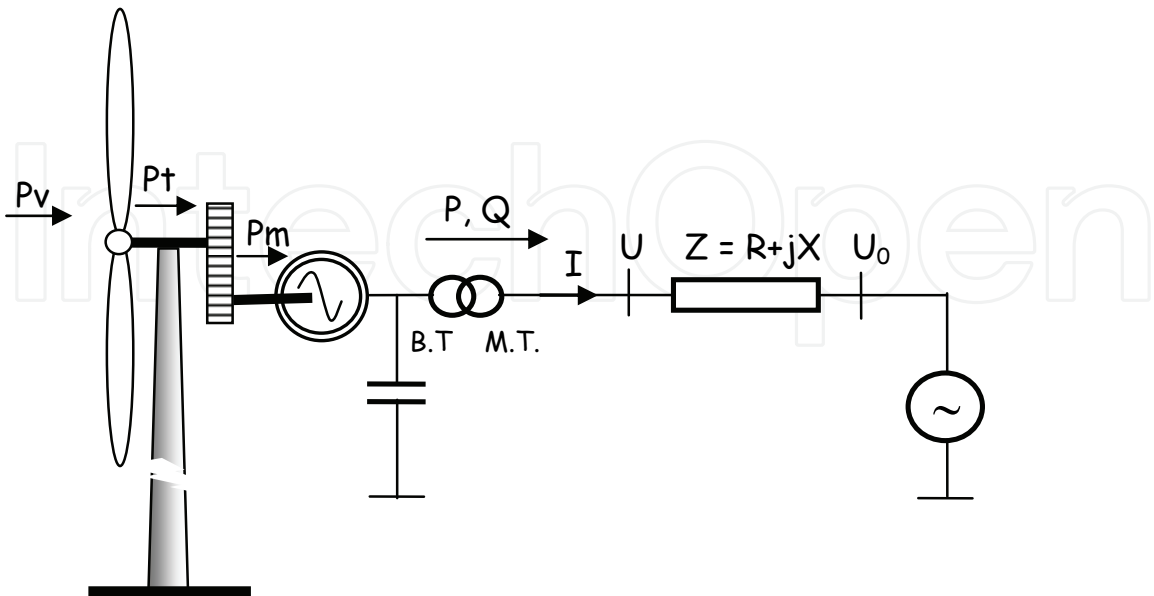

Fig. 3. Model of a generator directly connected to the grid

The active power  $P$  corresponds to that produced by the electric generator as a result of the mechanical power  $P_m$  provided by the set turbine-multiplier, converted from the wind power  $P_v$ . If the instantaneous power of the wind is constant, active power also would be. In practice, this ideal situation never shows up, either by variations in wind speed, of stochastic nature, or aerodynamic effects discussed in the previous section. As a result, the electric power will show, with a specific mitigation, such variations.

Regarding the reactive power, in an asynchronous machine it is related to the active power and the applied voltage. Assuming that the voltage is almost constant, the reactive power depends only on the active power. Typically, a capacitor compensates, at least, the reactive power consumed in an open circuit operation. However, nowadays it is usual to install capacitor banks that, automatically adjust the power factor at the turbine output to values close to one. When changes in power are important, the control system of the capacitor bank acts for an optimal reactive power compensation. Otherwise, if the variations are small, the capacitors remains at a fixed value. The switching in the battery should not be too frequent to limit the transients due to these operations (Thiringer et al., 2004).

In Spain, the Royal Decree 2818/1998 established that wind farms should operate with a power factor as close to unity as possible. Later, the operating procedure 7.4 (Ministerio de Industria y Energía de España, 2000) extended the band of operation of wind farms operating outside conventional generators, from 0.989 inductive to 0.989 capacitive. In this sense, there has been a shift in countries with high penetration of wind power, which has begun to require them to cooperate in the regulation of the supply voltage by an adequate flow of reactive power. This is achieved in the wind farms based on fixed speed asynchronous generators, through the installation of multi-stage capacitors at the substation. In the variable speed generators the regulation of reactive power is done by the control system of each turbine.

The impact of a wind farm on the voltage at the connection point can be studied from two viewpoints: the slow voltage variations and the fast variations.

#### **a. Slow voltage variations**

These are changes in the rms voltage expressed, typically, as average values in intervals of ten minutes. The injection of significant amounts of active and reactive power in the network causes local changes in the voltage that can affect other nearby users.

To predict the magnitude of the voltage variations attributable to the wind farm, two extreme situations should be considered: maximum (nominal) and minimum (zero) energy production, with the corresponding reactive power values. A more accurate calculation should include the other users and also requires to perform a load flow analysis (Tande, 2002). In this case, the extreme situations to be taken into account are the turbine maximum power generation and minimum power consumption (by other of users), and minimum wind power and maximum power consumed.

The limit of the permissible voltage variation at a particular node of the grid is fixed by the competent authorities in each area or, in other cases, by the power companies. In Spain, the Transport System Operator (TSO), REE, has fixed limits from 0.93 to 1.07 pu in the transmission grid.

In Sweden and Denmark the voltage variation in the distribution lines should not exceed 2.5%. This margin is extended to 5% (Larson, 1999) if wind turbines are the only elements connected.

Some authors (Larson, 1996) set the limit of the allowable percentage change in the LV networks in 3%, interpreting the curve provided by the IEC 868: *Flickermeter – Functional and*

design specifications, of 1986<sup>3</sup> (fig. 4). Based on this philosophy, but using the IEC 07/03/1000 (IEC, 1996)<sup>4</sup>, the curve to consider would be the one shown in fig. 5, obtained from the data included in this Standard for voltages of 230 V. In that document the fixed limits for compatibility are  $P_{st} = 1$  and  $P_{lt} = 0.8$  for LV and MV networks, and the emission limits  $P_{st} = 0.9$  (0.8) and  $P_{lt} = 0.7$  (0.6) for MV and HV grids.

The emission level of a fluctuating load is the level of *flicker* that occurs in the power system if there were no other fluctuating loads. We assume here that this definition is valid for generators.

The first value represented in the graph in figure 5 corresponds to a frequency of 0.1 changes per minute ( $8.33 \cdot 10^{-4}$  Hz), this means a change every ten minutes, and corresponds to a relative variation of the voltage of 7.364%. Taking into account the emission limit in MV we can conclude that every ten minutes the variation in voltage should not exceed  $0.9 \cdot 7,364 = 6.628\%$ .

Finally, according to EN 50160 (EN, 1999), applicable to MV and LV public distribution networks, in the period of a week, the permissible range for the variations of the rms voltage (averaged during 10 min) is  $\pm 10\%$  (percentile 95) and  $+10\%/-15\%$  to all the periods of 10 min.

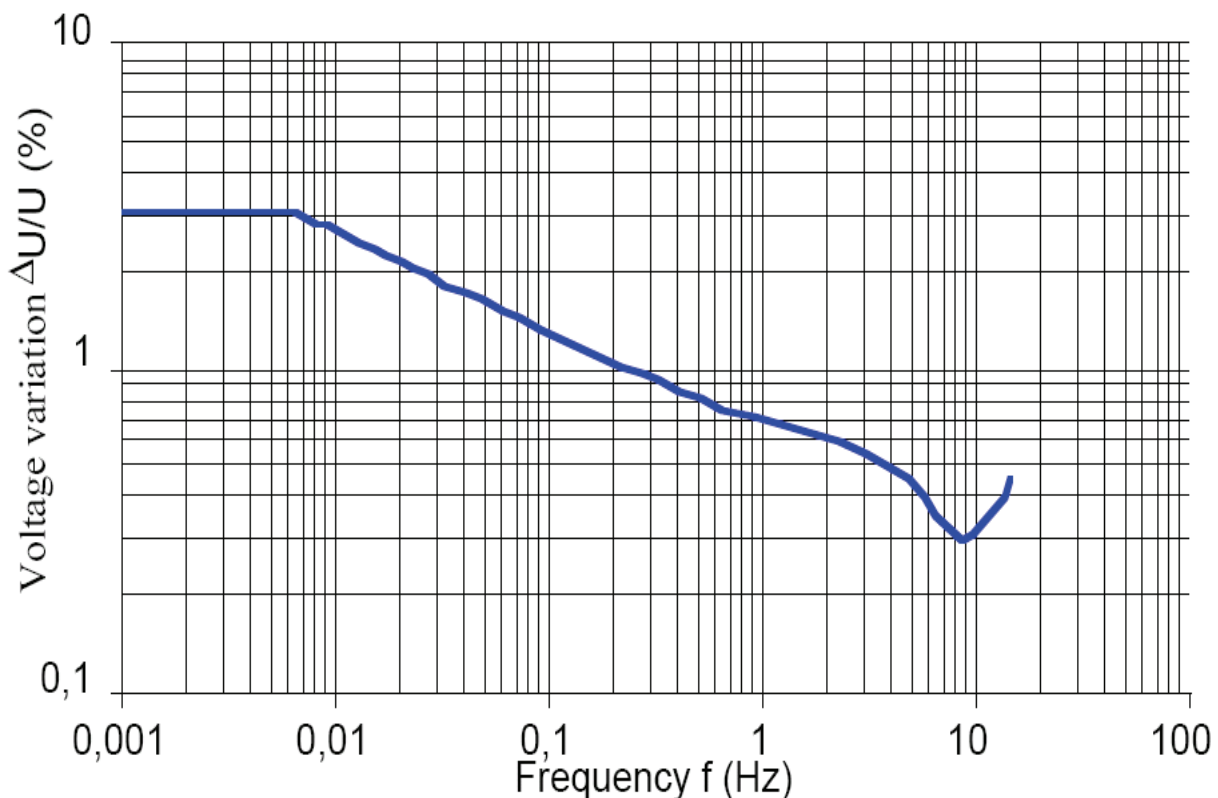

Fig. 4. Allowable limit of *flicker* according to IEC 868

<sup>3</sup> In Spain the UNE-EN 60868 was adopted in October 1995 [14].

<sup>4</sup> The values and graphics supplied by IEC 1000-3-7 reproduce, in turn, those of the IEC 1000-2-2 (EMC) - *Electromagnetic environment for low-frequency conducted disturbances and signalling in public power supply systems*- CEI 1990.

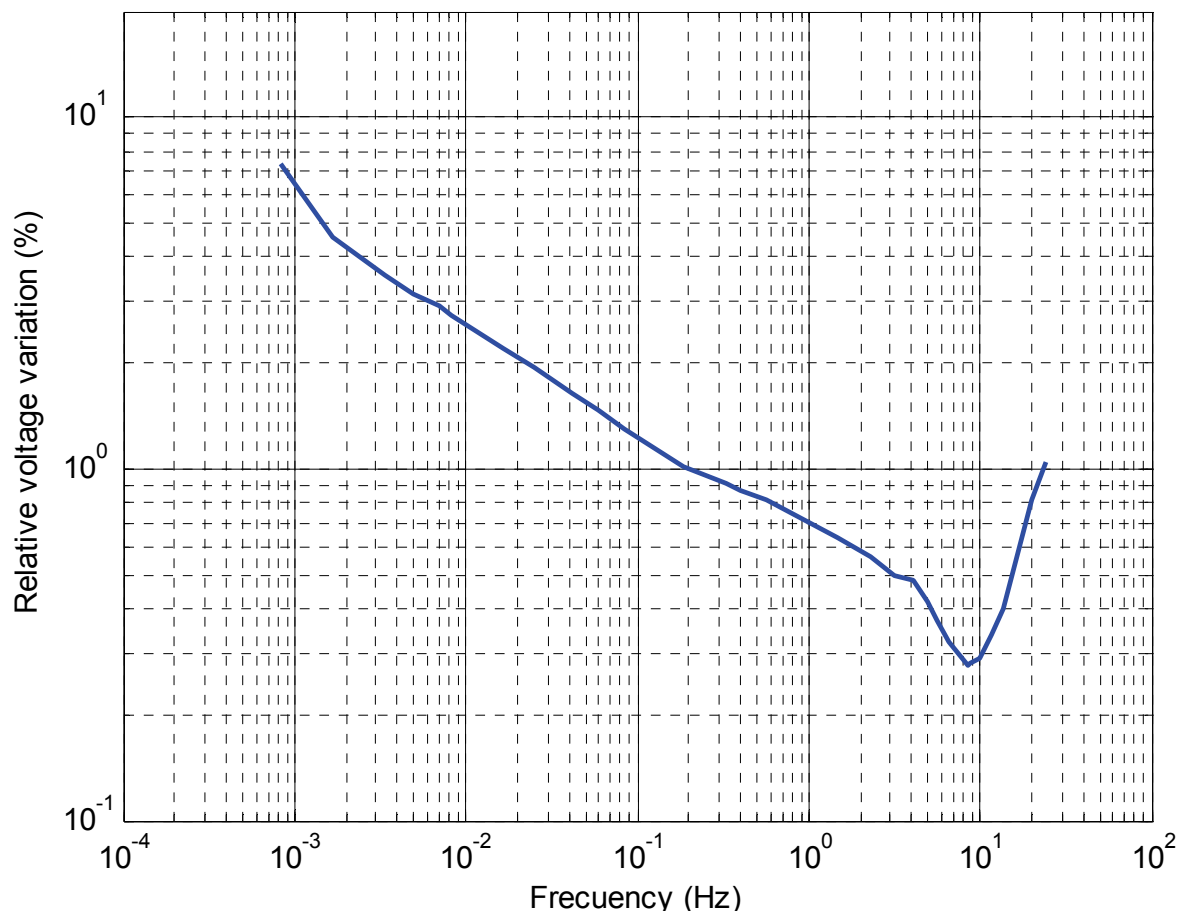

Fig. 5. Curve of  $P_{st} = 1$  for rectangular voltage variations in 230 V networks according to IEC 1000-3-7

#### b. Fast voltage variations (flicker)

When the voltage variations are faster, in the order of a few hertz, the problem that arises is the *flicker* phenomenon. Now the cause is not a variation of the average wind speed, but the gusts and turbulences of the wind, including those due to the effect of tower shadow and wind stratification seen before. The permissible limits are now narrower and more dependent on the frequency of the variations. The worst are those between 8.5 and 10 Hz, for which a rectangular voltage changes close to 0.3% would produce a  $P_{st}$  of value 1 and would, therefore, potentially produce discomfort to users (fig. 5). However, it seems more realistic to consider that the fast voltage variations are sinusoidal rather than rectangular. In this case the  $P_{st}$  unit curve would be as shown in figure 6.

Now the frequencies of interest are those corresponding to the blade passing ( $3p$ ). Thus, for a frequency of 1 Hz the allowable voltage variation would be of 2%, to 1.51% of 1.5 Hz, and to 2 Hz of 1.24%. These values are well above those obtained from the IEC 1000-3-7 (IEC, 1996), which for frequencies similar to those establishes: 0.725% to 0.92 Hz, 0.64% to 1.47 Hz and 0.56% to 2.27 Hz. The difference is due, as mentioned above, to the fact that this standard considers rectangular fluctuations, which are more disturbing than the sinusoidal ones.



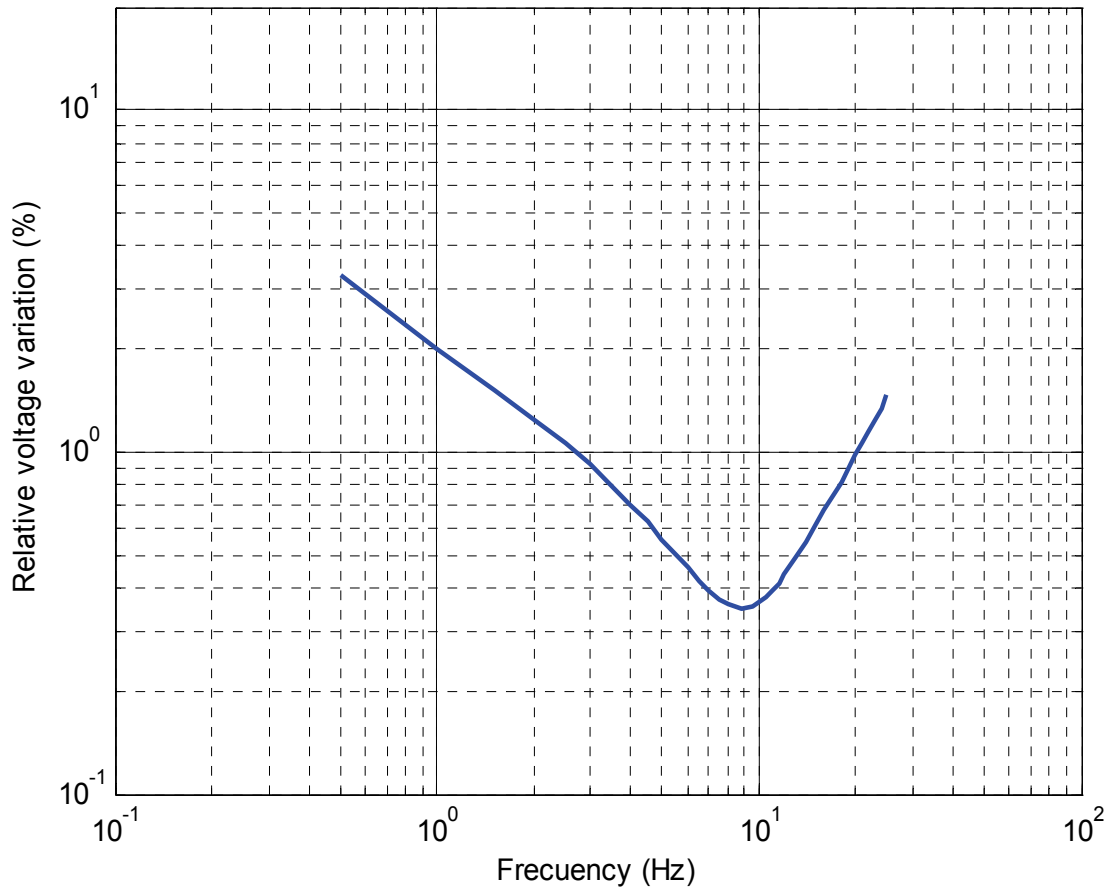

Fig. 6. Curve of  $P_{st} = 1$  for sinusoidal oscillations (according to IEC 61000-4-15)

### 3.2 Calculation of the slow voltage variations

According to the figure 3, the voltage drop through the equivalent impedance of the network ( $Z_0$ ) is responsible of the voltage variation at the connection point. The relative voltage drop thus is:

$$\Delta U = \frac{U - U_0}{U_0}$$

being  $U$  and  $U_0$  the rms phase voltages. The phase values of the active and reactive power generated by the wind farm are:

$$P = U \cdot I \cdot \cos \varphi; \quad Q = U \cdot I \cdot \sin \varphi \quad (1)$$

being  $\varphi$  the angle difference between the voltage and current. Figure 7 shows a phasor diagram illustrating the situation for a grid impedance of argument  $\psi = 45^\circ$ , this is, with equal real and imaginary parts ( $X/R = 1$ ).

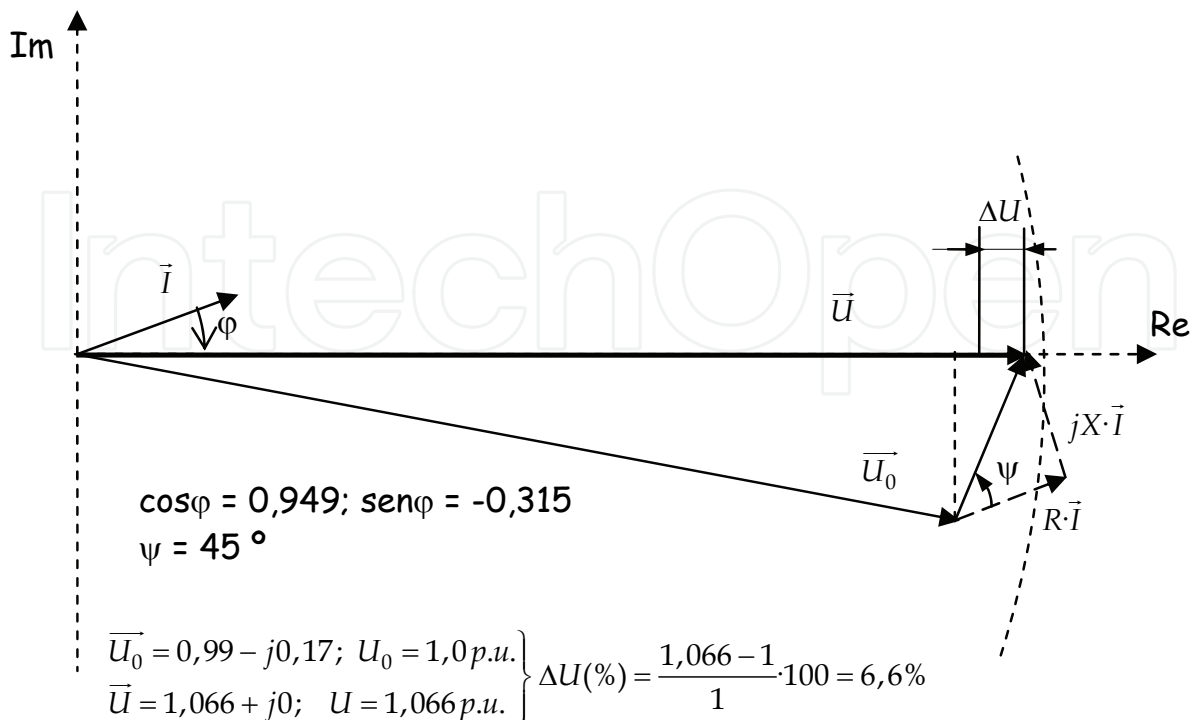

Fig. 7. Example of voltage drop for  $\cos \varphi = 0,949$  and  $\psi = 45^\circ$

In this example the generator is supplying active power and consuming reactive power, in similar proportions to those that would occur in an asynchronous generator with insufficient reactive compensation, resulting in a power factor of 0.95.

The geometrical figure formed by the points corresponding to the voltage of an infinite power network will be an arc of radius the rms voltage, in this case with a value of 1 pu. From the above circuit and diagram follows:

$$\vec{U} = \vec{U}_0 + R \cdot \vec{I} + jX \cdot \vec{I} = \vec{U}_0 + R(I \cos \varphi - jI \cdot \text{sen} \varphi) + jX(I \cos \varphi - jI \cdot \text{sen} \varphi)$$

$$\vec{U}_0 = U_{0R} + jU_{0X}$$

being  $U_{0R}$  and  $U_{0X}$ , the real and imaginary components of the phasor  $\vec{U}_0$ . Separating the complex voltage in the generator  $\vec{U}$  in its real and imaginary parts, and taking into account that the latter is zero, we obtain:

$$U = R \cdot I \cos \varphi + X \cdot I \cdot \text{sen} \varphi + U_{0R}$$

$$0 = -R \cdot I \cdot \text{sen} \varphi + X \cdot I \cos \varphi + U_{0X}$$

Solving for  $P$  and  $Q$  given in (1) and substituting in the previous,

$$I \cos \varphi = \frac{P}{U}; \quad I \sin \varphi = \frac{Q}{U}; \quad \Rightarrow \quad \begin{cases} U = \frac{R \cdot P + X \cdot Q}{U} + U_{0R} & (4.2) \\ \frac{R \cdot Q - X \cdot P}{U} = U_{0X} \end{cases} \quad (2)$$

Bearing in mind that

$$U_0 = \sqrt{U_{0R}^2 + U_{0X}^2} \Rightarrow U_{0R} = \sqrt{U_0^2 - \left(\frac{R \cdot Q - X \cdot P}{U}\right)^2}$$

On the other hand, as expression (2) may be written as:

$$U - \frac{R \cdot P + X \cdot Q}{U} = \sqrt{U_0^2 - \left(\frac{R \cdot Q - X \cdot P}{U}\right)^2}$$

from here:

$$U^2 + \left(\frac{R \cdot P + X \cdot Q}{U}\right)^2 - 2(R \cdot P + X \cdot Q) = U_0^2 - \left(\frac{R \cdot Q - X \cdot P}{U}\right)^2$$

finally:

$$U^4 - [2(R \cdot P + X \cdot Q) + U_0^2]U^2 + (R \cdot P + X \cdot Q)^2 + (R \cdot Q - X \cdot P)^2 = 0$$

Calling:

$$a = \frac{U_0^2}{2} + (R \cdot P + X \cdot Q) \quad (3)$$

$$b = (R \cdot P + X \cdot Q)^2 + (R \cdot Q - X \cdot P)^2 = Z^2 (P^2 + Q^2)$$

and taking into account that for  $Z = 0$ , which means  $b = 0$ , the voltages  $U$  and  $U_0$  must be equals, the rms voltage at the connection point ( $U$ ) results:

$$U = \sqrt{a + \sqrt{a^2 - b}} \quad (4)$$

$$\Delta U(p.u.) = \frac{U - U_0}{U_0}$$

The former expressions, as accurate as the assumptions adopted, are not useful for a physical or intuitive interpretation of the voltage variation. For this doing is more interesting to have an equation where it is evident the influence of each quantity over the relative variation of voltage. From expression (2) and approaching  $U_{0R} \approx U_0$  and  $U_{0R} \cdot U \approx U_0^2$  it results for the relative voltage variation:

$$\Delta U(p.u.) = \frac{U - U_0}{U_0} \approx \frac{U - U_{0R}}{U_0} = \frac{R \cdot P + X \cdot Q}{U_0 \cdot U} \approx \frac{R \cdot P + X \cdot Q}{U_0^2} \quad (5)$$

The above expression is commonly used to estimate the change in voltage produced by a facility that provides an active ( $P$ ) and reactive ( $Q$ ) powers, on an equivalent impedance grid  $\vec{Z} = R + jX$  of rated voltage  $U_0$  (Larson, 1999). As shown, the values of both powers, as the composition of the grid impedance have influence on this value.

The expression (5) shows that the active power voltage variation occurs in the resistive component of the network and the reactive power in the reactive component. Thus, in weak grids, predominantly resistive, as is the case of the typical MV distribution networks, the active power is the magnitude of greatest influence on the voltage variation. By contrast, in grids with high  $X/R$  ratios the reactive power is more important than the active.

Figure 8 shows the voltage variations obtained for different compositions of the equivalent grid impedance. For this doing, it has been considered an asynchronous generator connected to a grid whose short-circuit power is only ten times that of the generator.

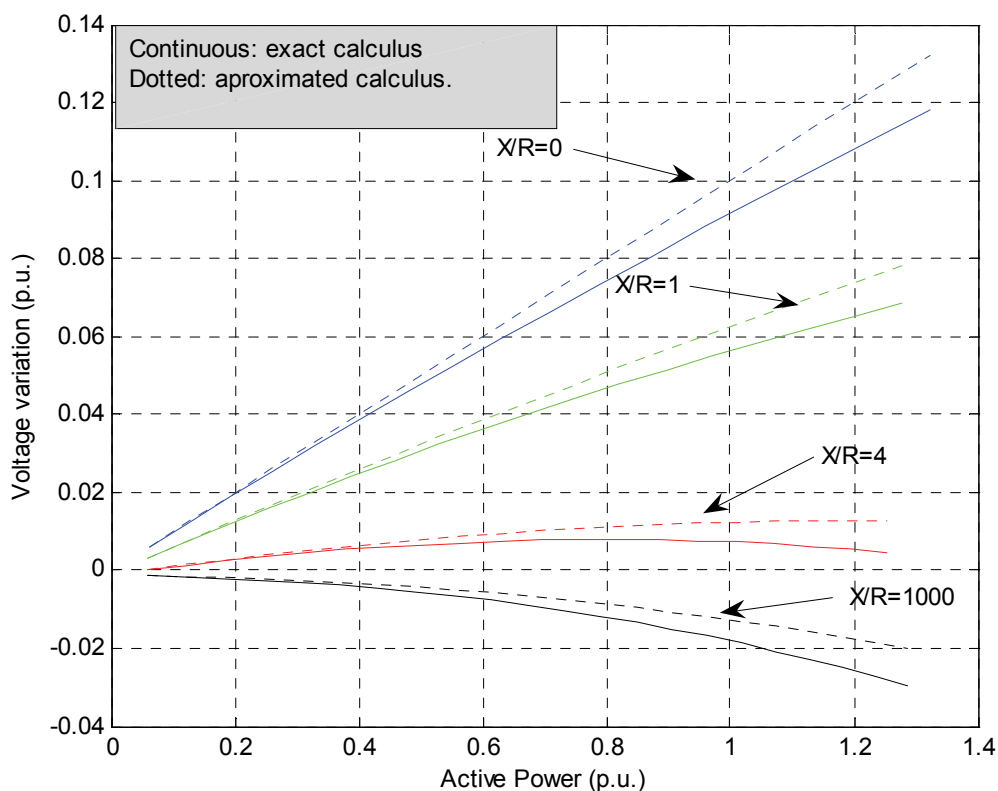

Fig. 8. Voltage variation for different  $X/R$  ratios according to the exact and approximated expressions

In the same figure it can be seen that the estimated values given by (5) (dotted lines), always gives voltage variations greater than the exact calculation (4).

At first glance, it looks that the estimation provides a certain margin of safety. However, this is not true because what is of relevance is the absolute value of the voltage variation, regardless of its sign. These curves were obtained with a generator whose  $P$ - $Q$  characteristic,

for the different cases studied, is shown in fig. 9. Since the voltage changes in different ways depending on the  $X/R$  ratio, so does the slope of the generator  $P$ - $Q$  characteristic.

As figure 9 shows, in a resistive grid, where the voltage rises further, the increase of reactive power demanded by the generator is partially compensated by the capacitor, while the grids in which the voltage rises less, the current increases more and so does the consumption of reactive by the leakage reactances of the windings.

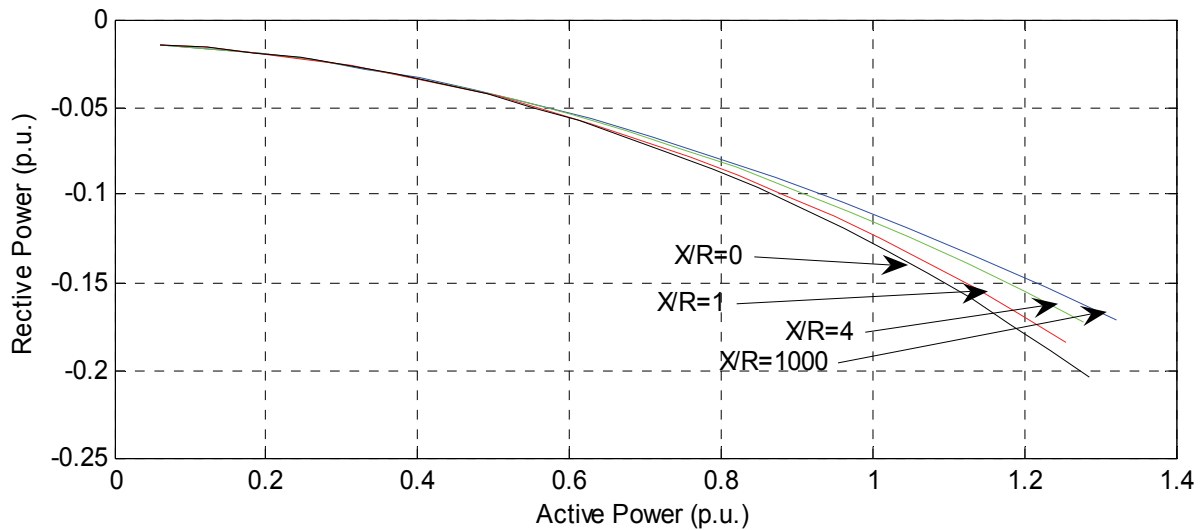

Fig. 9. Reactive power supplied versus active power (note that the scales are different)

Figure 10 shows the different phasor diagrams for the same values of  $X/R$  of the previous figures for the case of maximum power supplied by the generator.

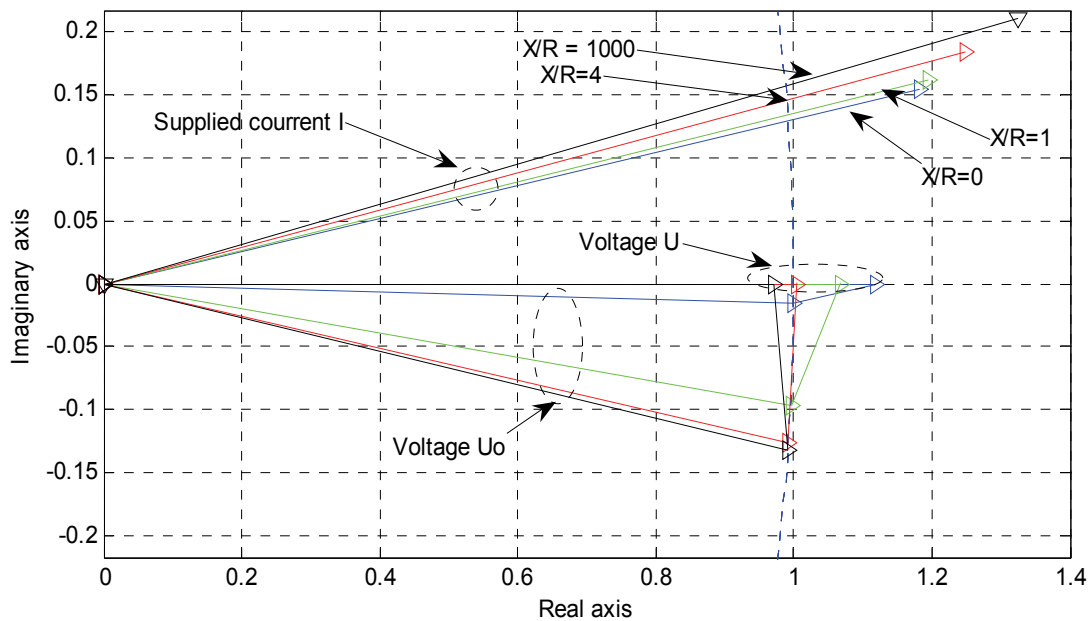

Fig. 10. Complex voltages and currents for maximum power values in fig 8 (note that the scales are different)

These graphics show clearly the reason for the greater increase of the voltage in resistive networks: the voltage drop in the impedance of the network has the smallest angular difference with the voltage. In contrast, in the example given, for  $X/R = 4$  the voltage in the impedance is almost perpendicular to that of the connection point  $\vec{U}_0$ , so it produces just a small voltage variation.

Different  $P$ - $Q$  curves of the set generator-capacitor bank, would give different families of voltage variation graphs similar to that of figure 8. One advantage of the approximate expression (5) is that it allows an immediate estimation not only on the relative changes in voltage but also in reactive power that, for a given active power and a certain equivalent impedance it produces a specific voltage variation (for example zero).

It also allows to calculate the  $X/R$  ratio which, for a given active and reactive power, produces a specific voltage variation. For example, in figure 9 it can be deduced that the machine consumes 0.12 pu of reactive power and 1 pu of active power. The zero voltage drop will occur when:

$$X / R = -P / Q = 8.33$$

As discussed below, this result is far from that obtained by more precise calculations. Indeed, comparing the voltage drops (in absolute value) obtained for a particular relationship between the short circuit power of the grid,  $S_{cc}$  and the active power supplied by the generator,  $P$  for different values of the ratio  $X/R$  of the grid impedance, using the exact expression (4) and the approximate (5), there are significant differences.

Figure 11 shows the absolute values of the voltage drops corresponding to a power ratio  $S_{cc}/P = 10$ . The dotted line corresponds to a quasi-exact expression, which is obtained before the last approximation of expression (5), evaluating the voltage  $U$  by using (2) and assuming  $U_0 \approx U_{0R}$ . The graphs show clearly the difference between the results obtained by each method. In addition, no voltage drop occurs, according to the approximate calculation for  $X/R = 8.33$  as previously obtained, but far from the value 5.8 obtained by the exact calculation method.

In view of all the above, it seems advisable to use the approximate expression (5) with some reservations. Some authors (Bossanyi et al., 1998) evaluate the error when using approximate methods for prediction of  $P_{st}$  up to 20%, so it is recommended to use the exact method, according to equation (4).

### 3.3 Fast voltage variations

So far it has been taken into account the maximum active power, with the corresponding reactive power put into play by a wind turbine to estimate the voltage variation in the worst case, this is, comparing the voltage at the PCC without power generated with the maximum production from wind turbines. In order to estimate the fast voltage variations, although its origin is also the variation of the power supplied by the wind turbines, the approach is slightly different.

First, the relationship between the active and reactive power depends on the area of operation of the machine, since the slope of the  $P$ - $Q$  characteristics is not constant (see fig. 9). Second, since the power fluctuation is essentially a local phenomenon of each turbine, it is necessary to determine how to add each other to assess the overall impact of an installation with several wind turbines.

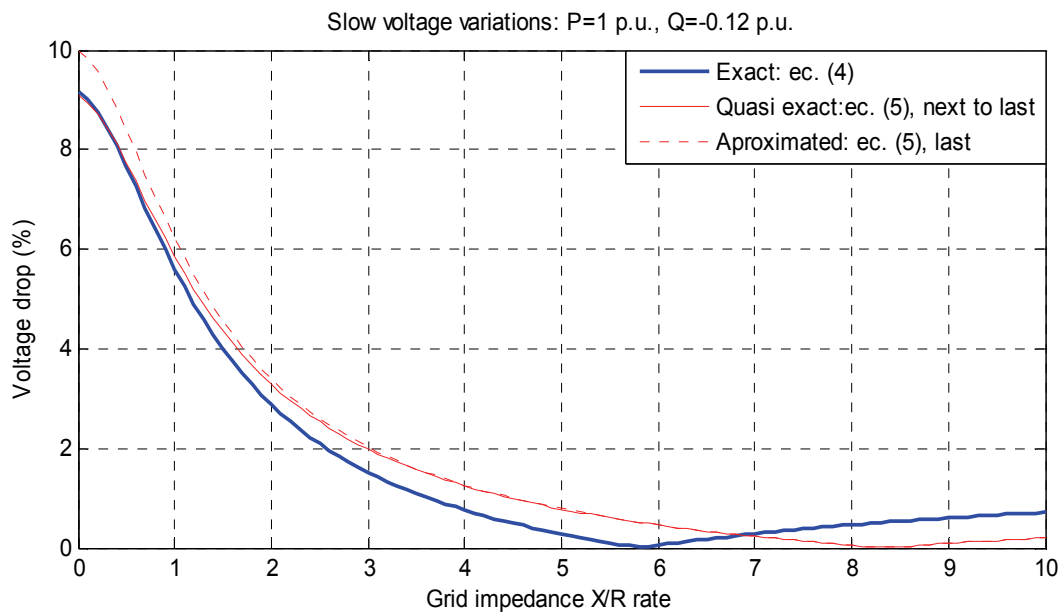

Fig. 11. Comparative calculation of the slow voltage variations

To calculate the voltage variation due to a generator whose output fluctuates around a mean value  $P_0$ , from the expression (2), eliminating the denominator and approaching  $U_{0R}$  by  $U_0$ , gives:

$$U^2 = R \cdot P + X \cdot Q + U \cdot U_0$$

from here:

$$2U \cdot dU = R \cdot dP + X \cdot dQ + U_0 \cdot dU$$

Since the initial data is the variation of the active power, it is of interest to express the variation of reactive power according to that:

$$dQ = \left( \frac{\partial Q}{\partial P} \right)_{P_0} \cdot dP = \alpha \cdot dP$$

being  $\alpha$  the slope of the  $P$ - $Q$  characteristic in the operating point of the generator. Substituting this last expression in the above equation and solving for the voltage variation:

$$dU = \frac{R \cdot dP + X \cdot dQ}{2U - U_0} \Rightarrow \frac{\Delta U}{U_0} \approx \frac{(R + \alpha \cdot X) \cdot \Delta P}{U_0^2} \text{ (p.u.)} \quad (6)$$

This expression coincides with that obtained directly from (5) which assumes, once again, that the voltage at the connection point ( $U$ ) and that of the infinite power grid  $U_0$  are very close.

For a value more adjusted to reality, although somewhat more complex to obtain, squaring and differentiating (4), it results:

$$2U \cdot dU = da + \frac{1}{2}(a^2 - b)^{-1/2} (2a \cdot da - db)$$

$$\frac{dU}{U_0} = \frac{2 \cdot da + (a^2 - b)^{-1/2} (2a \cdot da - db)}{4U \cdot U_0}$$
(7)

being  $da$  and  $db$  the differentials of the expressions  $a$  and  $b$  defined in (3):

$$da = R \cdot dP + X \cdot dQ = (R + \alpha \cdot X) dP$$

$$db = Z^2 (2P \cdot dP + 2Q \cdot dQ) = 2Z^2 (P + \alpha \cdot Q) dP$$

Similar to what was done in the slow voltage variations, it is interesting to compare the results obtained by calculating the fast variations of each method, assuming that the connected machine is the same as that used above (fig. 12). In this case we have taken active power variations of  $\pm 10\%$  compared to the nominal machine (20% of total variation). The slope of the  $P$ - $Q$  curve in  $P = 1$  p.u. is  $\alpha = -0.2$ , as seen in figure 9. The exact calculation is obtained by using (7) and the approximated calculation by using the expression (6) in a similar way as (5) was used for the slow variations.

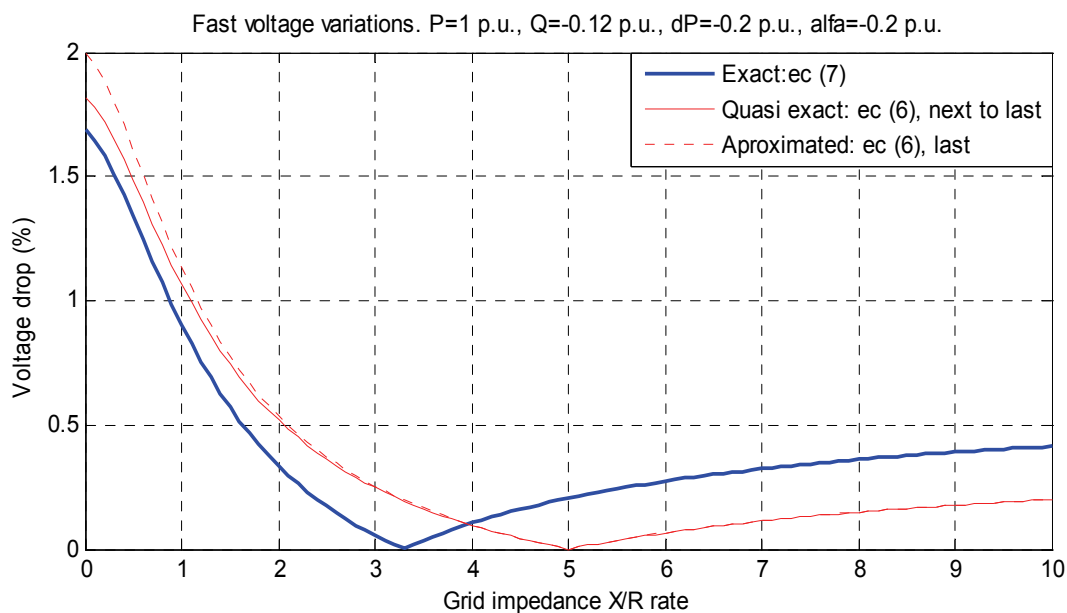

Fig. 12. Comparative calculation of the phase voltage variations

Again, significant differences arise between the two methods, so the conclusion is also the same: the estimation is simple but not very accurate, so it would not be recommend its use for estimating the *flicker*. The  $X/R$  ratio of the grid for which the voltage variation is zero is found to be 3.3 according to the exact calculation and 5 with the approximate one. From these values, the respective voltage drops, after passing through zero, change their sign, although the graphic merely shows the absolute value.



### 3.4 Power limit on a grid due to voltage drops

Until now we have evaluated separately the slow voltage variations, due to the injection of all the power of a generator in the grid, and the fast voltage variations, due to the stationary variation in the power with respect to a reference, such as the rated value.

To determine whether a generator can be connected to a particular grid, it should be taken into account both circumstances, considering the percentages of allowable voltage variation in both cases. Thus, knowing the  $P$ - $Q$  characteristic of a machine, supposing a certain amplitude and frequency of the power fluctuations and assuming certain allowable limits for the slow and fast voltage variations, it can be determined, for each value of the  $X/R$  ratio, the minimum short-circuit power of the grid not to exceed those limits.

As discussed above, the usual limits are 0.7% for fast variations at 1 Hz and 3% for the slow ones. Some authors (Larson, 1996) represent the curves of constant voltage variation equal to those limits and, therefore, delimit the areas where the variation of the voltage is higher or lower than those mentioned above.

Figure 13 shows separately the limit curves for slow and fast changes calculated by the different methods of the previous section (methods 2 and 3) and a third procedure consisting on solving the equations of the equivalent circuit of the machine in steady state, in order to validate the results obtained with the previous methods. It can be appreciated the coincidence between the exact and the one that uses the machine model, together with the mismatch of both with respect to the approximate method.

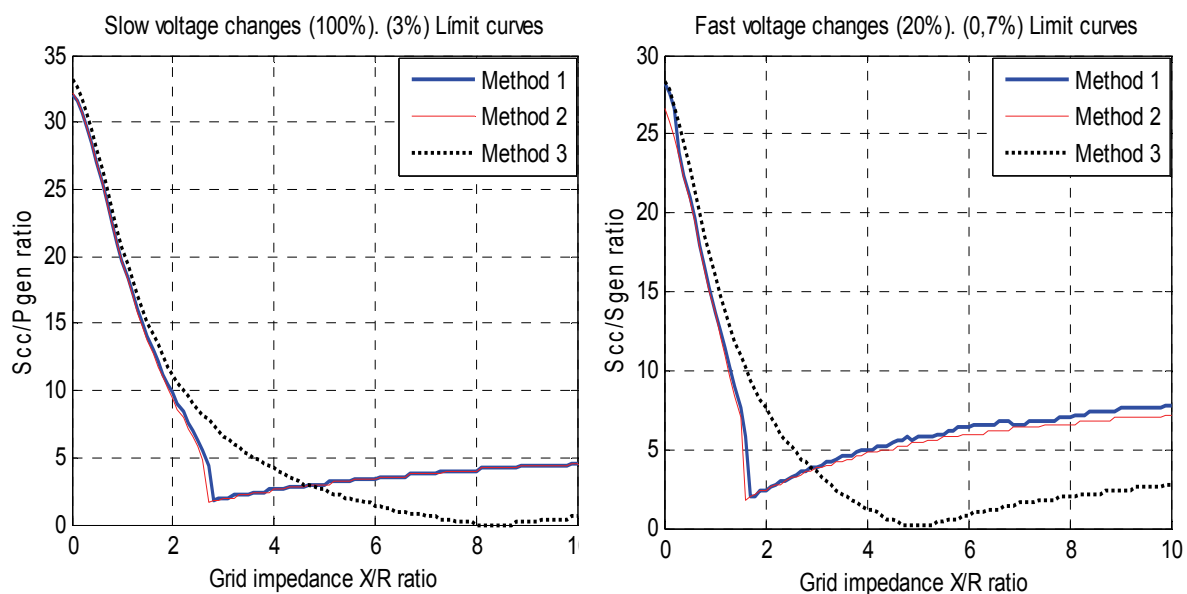

Fig. 13. Comparison of the limit curves obtained for different methods: Method 1: machine model, Method 2: exact analytical calculation, Method 3: approximate calculation.

Figure 14 shows together the two limit curves, very similar to those reported in previous studies (Larson, 1996). The area above the two curves is free of disturbances, since the fast and slow variations will be lower than the limits. Until the value of  $X/R = 2.7$  the slow voltage variations are responsible for limiting the minimum short-circuit power of the grid. For higher values of the  $X/R$  ratio, the responsible are the fast variations, this means the *flicker*. Logically, a change in the limits of the permissible voltage or in the  $P$ - $Q$  characteristic gives different curves.

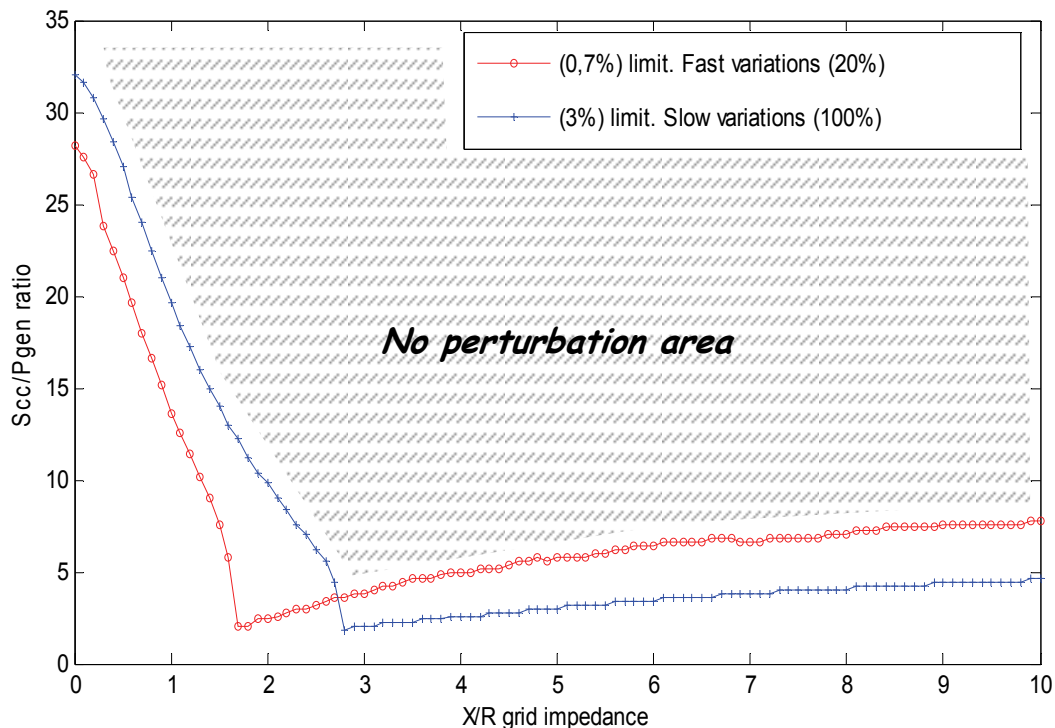

Fig. 14. Definition of areas of potential disturbance due to voltage variations

It should be noted that sometimes, the generator-grid model as that of figure 3 will be difficult to implement due to the ignorance of the exact parameters of the grid or because they vary along the time, for example, due to the presence of other users at the same PCC. In these cases it would be desirable a load flow analysis to determine the variation margins of the voltage (Tande et al. 2002). In this reference an example is given where the voltage variation, estimated by expression (5) is 68% and it is confirmed that, in practice, the variation is acceptable.

Other authors found no such discrepancy if not the opposite. Larson showed the match between the slow voltage variations measured and calculated in a real turbine (Larson, 1996) and also compared the results reached using the exact analytical calculation (4) and the load flow (Larson, 2000).

Figure 14 shows that one way to avoid significant voltage changes would be to impose, as a condition for the connection of a wind farm, that the short-circuit power of the grid at the connection point must be several times greater than the rated power of the wind farm. In Spain this approach is adopted since 1985 (Ministerio de Industria y Energía de España, 1985). For the authorization of a new wind farm, consisting of both synchronous and asynchronous generators, its rated power cannot exceed 1/20 of the short circuit power at the PCC.

### 3.5 Combined effect of several generators

Until now, we have considered the effect of a single generator connected to the grid. It is usual, in practice, to group a few dozen of wind turbines forming an installation which is called wind farm. As the distances to cover are usually a few kilometers, each generator (or

small group of them) has a transformer to raise the LV generated by the wind turbine (typically 690 V) to the value of the MV grid.

To estimate the total voltage distortion of a wind farm due to slow voltage variations, the effects of all generators may be taken into account on the basis of their active and reactive rated power. In other words, the wind farm could be considered as a single generator which power is equal to the sum of the powers of the single units.

Concerning the fast voltage variations, the question is not as simple because it is not realistic to assume that the power fluctuations are coincident in time (even assuming that they have the same magnitude in all the generators), neither that they may cancel each other. The practice is to follow the recommendation of the IEC1000-3-7 standard (IEC, 1996) considering that each turbine is responsible of a certain value of flicker,  $P_{sti}$  and, the combined effect of all the turbines can be taken into account by:

$$P_{st} = \sqrt[m]{\sum P_{sti}^m} \quad (8)$$

The value of  $m$  depends on the characteristics of the main sources of the fluctuations and can take values from 1 to 4. Value 4 is set for the cases in which the fluctuations should not be coincident and 1 for those other cases in which the probability of occurrence is very high. Value 2 is used in cases in which the coincidence is just as likely as that of random noise. That means that the fluctuations are not correlated. This is the most appropriate value to wind farms since, in principle, the disturbance of each turbine is independent of the others. This means that, in the usual case all the turbines are identical and all cause an individual disturbance  $P_{sti}$  which is equal for all of them; the global disturbance for  $N$  turbines will be:

$$P_{stN} = \sqrt{N \cdot P_{sti}^2} = \sqrt{N} \cdot P_{sti} \quad (9)$$

By the above expression, if the disturbance caused by a generator is proportional to its power, a single generator which power is equal to the sum of the powers of  $N$  generators will produce in the grid a disturbance  $N \cdot P_{sti}$ , clearly higher than the disturbance produced by  $N$  generators given by (9). This is due to the partial cancellation of the disturbances that occurs when the number of elements increases.

#### 4. Measurement and evaluation of the voltage fluctuations caused by wind turbines (CEI 61400-21)

According to the previous sections, the estimation of voltage variations that would produce a particular turbine or an entire wind farm into the grid would be conditioned by the use of one or another expression. It would also depend on the availability of the  $P$ - $Q$  characteristics of the generators (or in the overall substation) and the presumption of a certain fluctuation of the power supplied by the turbines. There is no doubt that there are too many uncertainties that would lead to results far from reality. For the sake of all the agents involved in the wind power sector it is necessary to clarify and to unify all the aspects related to the quality of power supplied by the wind turbines.

The UNE-EN 61400-21 2003 (EN, 2003) is the Spanish version of the European Standard of February 2002, which adopts the International Standard IEC 61400-21:2001. Its purpose is to provide a uniform methodology to ensure consistency and accuracy in measurement and evaluation of the quality of power supplied by the wind turbines connected to the grid.

Different reports describe briefly (Sorensen et al., 1999) or more extensively (Sorensen et al., 2001), the work, both experimental and theoretical, conducted as part of the project "European Wind Turbine Testing Procedure Developments" (Fourth Framework Program of the EU). This project is carried out by several EU States and it is coordinated by the Risø National Laboratory in Denmark. The aim of this project is to make recommendations for the new standard of measurement and testing of the power quality supplied by the wind turbines.

The works on the quality standards of the power supplied by the wind turbines began in 1995 by the IEC. At the end of 1998 there was already a draft of the IEC 61400-21. According to this standard, there are three parameters to evaluate the quality of supply:

- Steady voltage.
- Voltage fluctuations (in continuous operation and in switching operations).
- Harmonics.

#### 4.1 Measuring and testing. Fictitious network

For testing purposes, the turbine must be connected to the network through a MV standardized transformer and in a PCC with a short circuit power at least 50 times the maximum permissible power of the turbine.

Moreover, some requirements must be fulfilled. These requirements deal with the quality of the voltage at the PCC (rms value, frequency, unbalance and distortion) and the wind turbulence, which must be between 8% and 16%. The precision class required for the measurement equipment is 1.

Since the MV grid used in the test will have, in general, other loads, it is necessary to provide some mechanism to exclude any disturbances not attributable to the turbine itself. For this reason the standard specifies a method based on collecting temporal series of voltages and currents at the turbine terminals and the use of a circuit model, called *fictitious network* to determine, by calculation, the voltage fluctuations caused exclusively by the wind turbine.

The fictitious network (fig. 15) consists of an ideal voltage source  $u_0(t)$  in series with the grid resistance ( $R_{fic}$ ) and inductance ( $L_{fic}$ ). The wind turbine is represented as an ideal current source  $i_m(t)$  whose instantaneous value corresponds to the phase current measurements in the turbine during the test. The instantaneous value of  $u_{fic}(t)$  is given by equation (10).

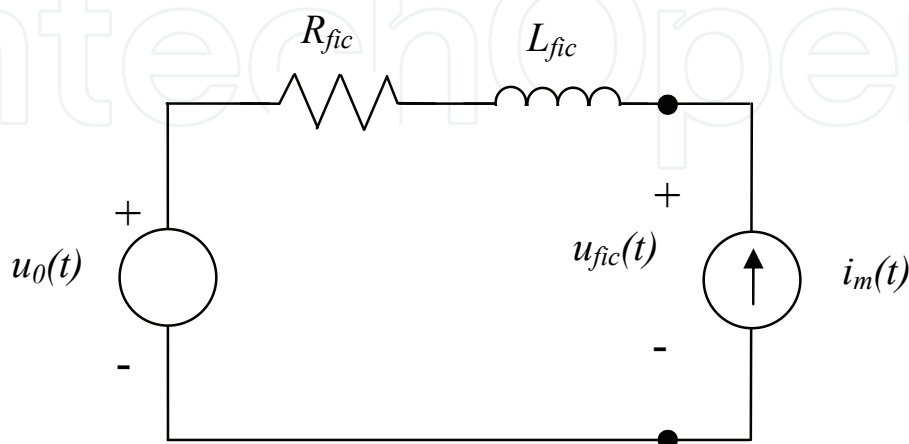

Fig. 15. Fictitious network according to UNE-EN 61400-21

$$u_{fic}(t) = u_0(t) + R_{fic} \cdot i_m(t) + L_{fic} \cdot \frac{di_m(t)}{dt} \quad (10)$$

Concerning the ideal voltage source, two properties must be fulfilled:

- the ideal voltage should contain no fluctuation, this is, the flicker on the voltage should be zero.
- $u_0(t)$  must have the same electrical angle,  $\alpha_m(t)$ , than the fundamental component of the measured voltage. This ensures that the phase angle between  $u_{fic}(t)$  and  $i_m(t)$  is correct, provided that  $|u_{fic}(t) - u_0(t)| \ll |u_0(t)|$ .

To comply with the conditions imposed in the standard  $u_0(t)$  and  $\alpha_m(t)$  are defined as:

$$\left. \begin{aligned} \alpha_m &= 2 \cdot \pi \cdot \int_0^t f(t) dt + \alpha_0 \\ u_0(t) &= \sqrt{\frac{2}{3}} \cdot U_n \cdot \text{sen}(\alpha_m(t)) \end{aligned} \right\} \quad (11)$$

where  $f(t)$  is the frequency,  $\alpha_0$  is the electrical angle at  $t = 0$  and  $U_n$  the rms value of the rated grid voltage. The values of  $R_{fic}$  and  $L_{fic}$  are chosen to get grid angles ( $\psi_k$ ) of 30°, 50°, 70° and 85° ( $X_{fic}/R_{fic} = 0.577; 1.19; 2.75; 11.43$ ) and a short-circuit power which, *as a guide, it is suggested to be 50 times higher than the rated power of the turbine.*

The instantaneous voltage  $u_{fic}(t)$  obtained by expression (10) is introduced into an algorithm that meets IEC specifications for the flickermeter (according to IEC 61000-4-15) to obtain the value of  $P_{st,fic}$ . From it the flicker coefficient is obtained by:

$$c(\psi_k) = P_{st,fic} \cdot \frac{S_{k,fic}}{S_n} \quad (12)$$

Where  $S_n$  is the rated power of the wind turbine and  $S_{k,fic}$  is the short circuit power of the fictitious grid.

Continuing with the standard, for the test of the turbine, the temporal series of voltage and current measurements should be obtained for steps of wind speed of 1 m/s, between the speed of onset and 15 m/s. It is commonly accepted, and so is assumed in the standard, that the annual distribution of wind speed (integrated in values each 10 minutes) in a particular location is often adapted to the *Rayleigh Law*, the function of cumulative probability distribution is given by:

$$F(v) = 1 - e^{-\frac{\pi}{4} \left( \frac{v}{v_a} \right)^2}$$

being  $v$  the wind speed and  $v_a$  its annual average. If the flicker coefficients,  $c(\psi_k)$ , obtained for each wind speed are multiplied by a weighting factor that takes into account the probability of occurrence of that speed for a given annual average of the wind speed, another flicker coefficients can be obtained  $c(\psi_k, v_a)$ , which are a function of the angle of the grid impedance and the annual average wind speed,  $v_a$  (the average speeds to consider are: 6 m/s, 7.5 m/s and 8.5 m/s).

The standard details the calculation procedure to obtain these coefficients, which represent the 99<sup>th</sup> percentile of each distribution. The test result, concerning the continuous operation, will be a table of flicker coefficients  $c(\psi_k, v_a)$  (included in the standard). From the table of coefficients, the emission of flicker (99<sup>th</sup> percentile) of a wind turbine during continuous operation should be estimated by the expression:

$$P_{st} = P_{lt} = c(\psi_k, v_a) \cdot \frac{S_n}{S_k} \quad (13)$$

being  $S_n/S_k$  the relationship between the rated power of the turbine and the network short circuit power at the point of connection. Since the grid angle  $\psi_k$  and the annual wind speed  $v_a$ , in a particular site will, generally, not match those in the table, the flicker coefficient  $c(\psi_k, v_a)$  should be obtained by interpolation of those.

The standard also specifies that in cases where several turbines are connected, the emission of flicker can be estimated by:

$$P_{st\Sigma} = P_{lt\Sigma} = \frac{1}{S_k} \cdot \sqrt{\sum_{i=1}^{N_{wt}} (c_i(\psi_k, v_a) \cdot S_{n,i})^2} \quad (14)$$

being  $i$  each of the  $N_{wt}$  turbines. This expression is equivalent to (8), proposed in the IEC 1000-3-7.

## 5. Conclusions

In this chapter it is studied the way in which power fluctuations from asynchronous fixed-speed wind turbines become voltage variations. Although it might seem rather obvious, the need to use as variables of analysis the active and reactive power involves either the use of simple but approximate expressions, or complex and more accurate. Moreover it must be added that it is an asynchronous machine which acts as a power source, according to its P-Q characteristic. The issue has been addressed theoretically, obtaining the more or less approximate expressions that appear in the references concerning the subject. The results by using the above expressions have been compared by computer simulations. It has been shown that some widely used expressions may yield in inaccurate results.

Following the pattern of other researchers, the influence of the grid parameters where the generator is connected have been taken into account for the evaluation of slow and fast voltage variations. The relationship between the resistive and reactive components of the network impedance is shown as a crucial factor in the magnitude of the resulting voltage fluctuations. Therefore it is essential in deciding whether a grid supports the injection of a given power limitations based on the slow or fast voltage variations produced.

## 6. References

- Bossanyi, E.; Saad-Saoud, Z & Jenkins, N. (1998). *Prediction of flicker produced by wind turbines*. Wind Energy, 1, pp. 35-51.
- Cidrás J. & Feijóo A., (2002). *A Linear Dynamic Model for Asynchronous Wind Turbines With Mechanical Fluctuations*. IEEE Trans. On Power Systems, Vol. 17, N° 3.

- EN (1997). UNE-EN 60868: *Medidor de Flicker. Parte 0: Especificaciones funcionales y de diseño*. AENOR.
- EN (1999). UNE-EN 50160: *Características de la tensión suministrada por las redes generales de distribución*. AENOR.
- EN 61400-21: *Medida y evaluación de las características de la calidad de suministro de las turbinas eólicas conectadas a la red*. AENOR 2003
- IEC (1996). EC 1000-3-7: (EMC): *Assessments of emission limits for fluctuating loads in MV and HV power systems*.
- Larson A. (1996). *Flicker and Slow Voltage Variations from Wind Turbines*. Proc. of the 7<sup>th</sup> International Conference on Harmonics and Quality of Power (ICHQP'96), Las Vegas, USA, pp. 270-275. October 1996.
- Larson A. (1999), *Guidelines for Grid Connection of Wind Turbines*. 15<sup>th</sup> International Conference on Electricity Distribution (CIRED'99). Niza, France, June 1999.
- Larson A., (2000) *The Power Quality of Wind Turbines*. Ph.D. Thesis. Chalmers University of Technology, Goteborg, Sweden 2000.
- Ministerio de Industria y Energía de España (1985). Orden Ministerial de 5 de septiembre de 1985: *Normas Administrativas y Técnicas para el Funcionamiento y Conexión a las Redes Eléctricas de Centrales Hidroeléctricas de hasta 5.000 KVA y Centrales de Autogeneración Eléctrica*. B.O.E., 12 September 1985.
- Ministerio de Industria y Energía de España (2000). *Resolución de 10 de marzo de 2000, de la Secretaría de Estado de Industria y Energía, por la que se aprueba el procedimiento de operación del sistema (P.O. - 7.4) "Servicio complementario de la tensión de la re de transporte"*. BOE n°. 67, 18 Mars 2000.
- Papathanassiou, S.A. & Papadopoulus, M.P. (1999). *Dynamic Behavior of Variable Speed Wind Turbines under Stochastic Wind*. IEEE Transactions on Energy Conversion, Vol. 14, No. 4.
- Pierik, J.T.G.; Morren, J.; Wiggelinkhuizen, E.J.; de Haan, S.W.H.; van Engelen, T.G. & Bozelie, J. (2004). *Electrical and Control Aspects of Offshore Wind Farms II (Erao II). Volume 1: Dynamic models of wind farms*. ECN. TUDelft (Holland).
- Sorensen P.; Gerdes G.; Klosse R.; Santier F.; Robertson N.; Davy W.; Koulouvary M.K.; Morfiadakis E. & Larson A. (1999), *Standards for Measurements and Testing of Wind Turbine Power Quality*. European Wind Energy Conference (EWEC'99). Niza, France, Mars 1999.
- Sorensen P.; Pedersen T.F.; Gerdes G.; Klosse R.; Santier F.; Robertson N.; Davy W.; Koulouvary M.K.; Morfiadakis E. & Larson A. (2001). *European Wind Turbine Testing Procedure Developments. Task 2: Power Quality*. Riso-R-1093(EN). Riso National Laboratory, Denmark.
- Takata G.; Katayama N.; Miyaku M. & Nanahara T. (2005). *Study on Power Fluctuation Characteristics of Wind Energy Converters with Fluctuating Turbine Torque*. Electrical Engineering in Japan, vol. 153, N° 4.
- Tande, J. O. (2002). *Applying Power Quality Characteristics of Wind Turbines for Assessing Impact on Voltage Quality*. Wind Energy, 5:37-52.
- Thiringer T. (1996). *Power Quality Measurements Performed on a Low-Voltage Grid Equipped With Two Wind Turbines*. IEEE Trans. on Energy Conversion, Vol. 11, N° 3, pp.601-606.
- Thiringer T. & Dahlberg J-A. (2001). *Periodic Pulsations from a Three-Bladed Wind Turbine*. IEEE Trans. on Energy Conversion, Vol. 16, N° 2, pp. 128-133.
- Thiringer T.; Petru T. & Lundberg S. (2004). *Flicker Contribution From Wind Turbine Installations*. IEEE Trans. on Energy Conversion, Vvol. 19, N° 1, pp. 157-163.

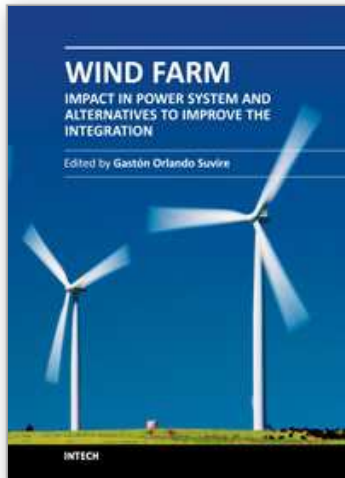

## **Wind Farm - Impact in Power System and Alternatives to Improve the Integration**

Edited by Dr. Gastón Orlando Suvire

ISBN 978-953-307-467-2

Hard cover, 330 pages

**Publisher** InTech

**Published online** 28, July, 2011

**Published in print edition** July, 2011

During the last two decades, increase in electricity demand and environmental concern resulted in fast growth of power production from renewable sources. Wind power is one of the most efficient alternatives. Due to rapid development of wind turbine technology and increasing size of wind farms, wind power plays a significant part in the power production in some countries. However, fundamental differences exist between conventional thermal, hydro, and nuclear generation and wind power, such as different generation systems and the difficulty in controlling the primary movement of a wind turbine, due to the wind and its random fluctuations. These differences are reflected in the specific interaction of wind turbines with the power system. This book addresses a wide variety of issues regarding the integration of wind farms in power systems. The book contains 14 chapters divided into three parts. The first part outlines aspects related to the impact of the wind power generation on the electric system. In the second part, alternatives to mitigate problems of the wind farm integration are presented. Finally, the third part covers issues of modeling and simulation of wind power system.

### **How to reference**

In order to correctly reference this scholarly work, feel free to copy and paste the following:

Carlos Lopez and Blanes (2011). Voltage Fluctuations Produced by the Fixed-Speed Wind Turbines during Continuous Operation. European Perspective, Wind Farm - Impact in Power System and Alternatives to Improve the Integration, Dr. Gastón Orlando Suvire (Ed.), ISBN: 978-953-307-467-2, InTech, Available from: <http://www.intechopen.com/books/wind-farm-impact-in-power-system-and-alternatives-to-improve-the-integration/voltage-fluctuations-produced-by-the-fixed-speed-wind-turbines-during-continuous-operation-european->

**INTECH**  
open science | open minds

#### **InTech Europe**

University Campus STeP Ri  
Slavka Krautzeka 83/A  
51000 Rijeka, Croatia  
Phone: +385 (51) 770 447  
Fax: +385 (51) 686 166  
[www.intechopen.com](http://www.intechopen.com)

#### **InTech China**

Unit 405, Office Block, Hotel Equatorial Shanghai  
No.65, Yan An Road (West), Shanghai, 200040, China  
中国上海市延安西路65号上海国际贵都大饭店办公楼405单元  
Phone: +86-21-62489820  
Fax: +86-21-62489821



© 2011 The Author(s). Licensee IntechOpen. This chapter is distributed under the terms of the [Creative Commons Attribution-NonCommercial-ShareAlike-3.0 License](#), which permits use, distribution and reproduction for non-commercial purposes, provided the original is properly cited and derivative works building on this content are distributed under the same license.

IntechOpen

IntechOpen