

# We are IntechOpen, the world's leading publisher of Open Access books Built by scientists, for scientists

**4,800**

Open access books available

**122,000**

International authors and editors

**135M**

Downloads

Our authors are among the

**154**

Countries delivered to

**TOP 1%**

most cited scientists

**12.2%**

Contributors from top 500 universities



**WEB OF SCIENCE™**

Selection of our books indexed in the Book Citation Index  
in Web of Science™ Core Collection (BKCI)

Interested in publishing with us?  
Contact [book.department@intechopen.com](mailto:book.department@intechopen.com)

Numbers displayed above are based on latest data collected.

For more information visit [www.intechopen.com](http://www.intechopen.com)



# Optimal Design of Cooling Water Systems

Eusiel Rubio-Castro, José María Ponce-Ortega  
and Medardo Serna-González

*Chemical Engineering Department, Universidad Michoacana de San Nicolás de Hidalgo  
México*

## 1. Introduction

Re-circulating cooling water systems are generally used to remove waste heat from hot process streams in conditions above the ambient temperature in many types of industries such as chemical and petrochemical, electric power generating stations, refrigeration and air conditioning plants, pulp and paper mills, and steel mills. Typical re-circulating cooling water systems are constituted by a mechanical draft wet-cooling tower that provides the cooling water that is used in a set of heat exchangers operated in parallel as can be seen in Figure 1. The economic optimization of re-circulating cooling water systems includes the simultaneous selection of the optimal design variables of the cooling tower and each heat exchanger in the cooling network, as well as the optimal structure of the cooling water network. The question is then how to reach this goal. Earlier work on cooling water systems has concentrated on the optimization of stand-alone components, with special attention given on the individual heat exchangers of the cooling water network. Other publications have dealt with the problem of designing minimum-cost cooling towers for a given heat load that must be dissipated (see Söylemez 2001, 2004; Serna-González et al., 2010). Most of the methodologies previously reported have concentrated their attention in the optimal synthesis of cooling water networks (see Kim and Smith, 2001; Feng et al., 2005; Ponce-Ortega et al., 2007). All previous formulations simplified the network configurations because they consider the installation of only one cooling tower; however, the industrial practice shows that sometimes it is preferable to use a set of cooling towers connected in series, parallel, and series-parallel arrangements to improve the performance of the cooling towers reducing the operational cost and, hence, to decrease the overall total annual cost for the cooling water system. In addition, previous methodologies do not have considered several arrangements for the cooling water that can improve the performance in the coolers and reduce their capital costs. Another limitation for the previously reported methodologies is that they are based on the use of simplified formulations for the design of cooling towers.

This chapter presents an optimization model for the simultaneous synthesis and detailed design of re-circulating cooling water systems based on the superstructure of Figure 2. The model considers all the potential configuration of practical interest and the results show the significant savings that can be obtained when it is applied.

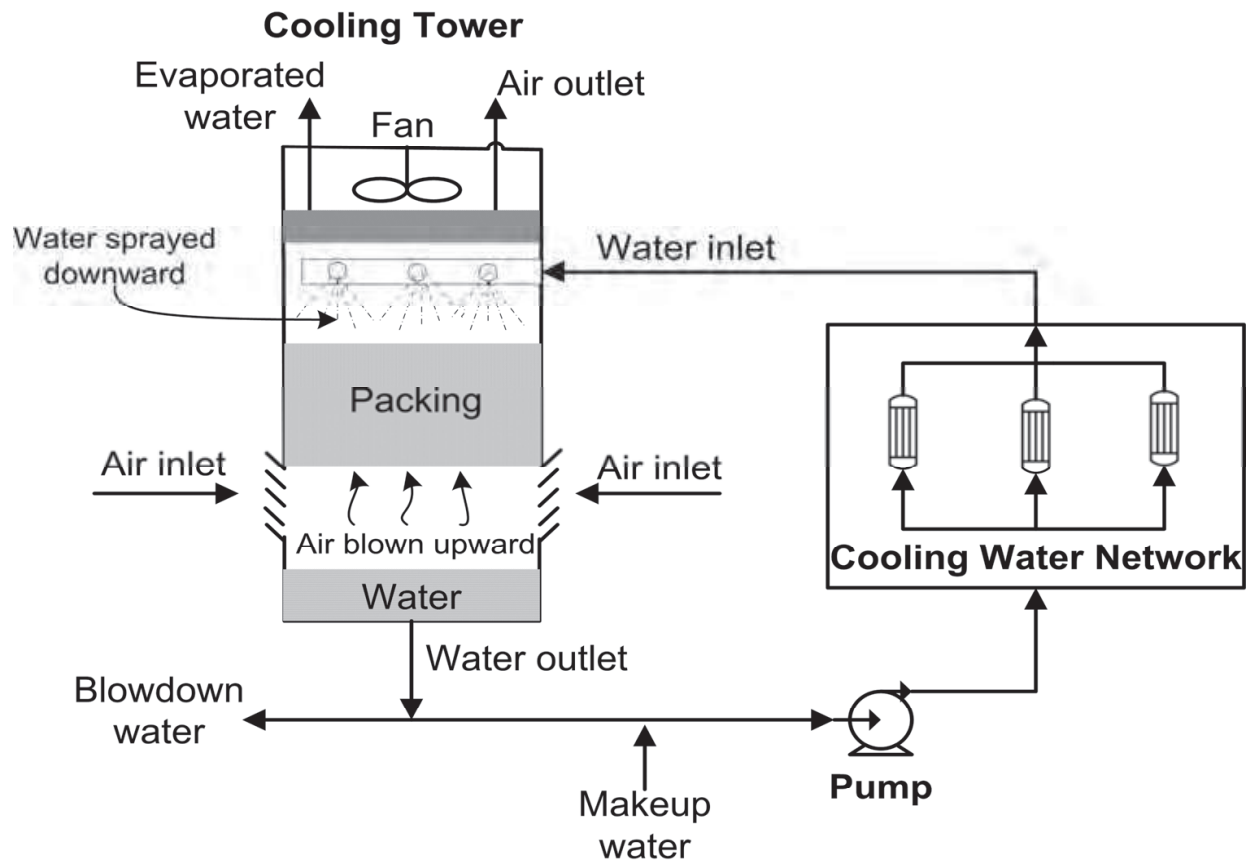

Fig. 1. Typical cooling water system.

## 2. Model formulation

This section presents the relationships for the proposed model, which is based in the superstructure of Figure 2. In the next equations, the set NEF represents the cooling medium streams leaving the cooler network, *ST* the stages of the cooling network, *HP* the hot process streams and *NCT* represents the cooling towers. The subscripts *av, b, cu, d, dis, ev, f, fi, fr, i, j, k, e, l, m, in, n, nct, out, p, pl, r, s, t* and *WB* are used to denote average, blowdown, cooling medium, drift, end of the cooling tower network, evaporation, fan, fill, cross-sectional, hot process stream, cold process stream, stage in the cooling network, type of packing, constants to calculate the heat and mass transfer characteristics for a particular type of packing, constants for the loss coefficient correlation for a particular type of packing, inlet, temperature increment index, cooling tower, outlet, pump, parallel arrangement, makeup, series arrangement, total and wet-bulb, respectively. The superscript *max* is an upper limit and *min* is a lower limit. In addition, the scalars *NOK* is the total number of stages in the cooling network, *NCP* is the total number of cooling medium streams at the hot end of the cooling network and *LCT* is the last cooling tower in the cooling tower network.

The heat of each hot process stream ( $Q_{HP_i}$ ) is calculated by the multiplication between the heat capacity flowrate of each hot process stream ( $FCP_i$ ) and the difference of the inlet and outlet temperatures of each stream ( $THIN_i, THOUT_i$ ). All terms of the above equation

$$(THIN_i - THOUT_i)FCP_i = Q_{HP_i} \quad (1)$$



where  $F_{i,k}$  is the flowrate for the cooling medium in each match. In addition,  $Th_{i,k}$  is the temperature of each hot stream in each match,  $Tcin_k$  is the inlet temperature for the cooling medium in each stage,  $Tcout_{i,k}$  is the outlet temperature for the cooling medium in each match and  $CP_{cu}$  is the heat capacity for the cooling medium. In previous equations,  $CP_{cu}$  is a parameter known prior to the optimization process.

Mass and energy balances are required to calculate the inlet flow rate and temperature for the cooling water to each stage. For the  $k$ th stage of the cooler network, the mass balance in the mixer is given by the sum of the water flow rates that are required by the matches in that stage ( $\sum_{i \in HP} F_{i,k}$ ) and the supply cold-water flow rate to the hotter adjacent stage  $k+1$  ( $FF_{k+1}$ ) minus the sum of the bypass water flow rate ( $FO_k$ ) running from the splitter of that stage to the cooler network outlet and the flow rates of cooling water streams that are required by the matches of the hotter adjacent stage  $k+1$  ( $\sum_{i \in HP} F_{i,k+1}$ ),

$$\sum_{i \in HP} F_{i,k} + FF_{k+1} = FO_k + \sum_{i \in HP} F_{i,k+1}, \quad k \in ST - 1 \quad (5)$$

To calculate the temperature of the bypass cooling-water stream of each stage ( $TO_k$ ), the following heat balance in the splitters is required,

$$\left( \sum_{i \in HP} F_{i,k} \right) TO_k = \sum_{i \in HP} (F_{i,k} Tcout_{i,k}), \quad k \in ST - 1 \quad (6)$$

Note that using the heat balance given in equation (4) is possible to know the inlet cooling medium temperature ( $Tcin_{k \neq 1}$ ) to each stage, except to the first one (i.e., for  $k = 1$ ). And for the first stage, the cooling medium temperature is given by the cooling tower,

$$\left( \sum_{i \in HP} F_{i,k} \right) TO_k + FF_{k+1} TCU_{in} = FO_k TO_k + \sum_{i \in HP} (F_{i,k+1} Tcin_{k+1}), \quad k \in ST - 1 \quad (7)$$

The above set of equations is necessary for  $NOK-1$  stages.

The following mass balance must be included for the first stage to determine the flowrate of the cold water provided by the cooling tower network to the cooler network, considering that only cold water is used in the first stage.

$$FF_k = \sum_{i \in HP} F_{i,k}, \quad k = 1 \quad (8)$$

The inlet temperatures of the hot process streams define the last location for the superstructure. In other words, the inlet temperature of the hot process stream  $i$  is the temperature of such stream in the hot end of the cooling network ( $Th_{i,NOK+1}$ ),

$$THIN_i = Th_{i,NOK+1}, \quad i \in HP \quad (9)$$

The outlet temperatures of hot process streams give the first location for the superstructure. Therefore, the outlet temperature of the hot process stream  $i$  is the temperature of such stream in the cold end of the cooling network ( $Th_{i,1}$ ),

$$THOUT_i = Th_{i,1}, \quad i \in HP \quad (10)$$

In addition, the inlet temperature for the cooling medium ( $TCUIN$ ) represents the inlet temperature at the first stage ( $Tcin_1$ ), considering that the outlet temperature in each match is restricted by an upper limit ( $\Omega_{T_{cout_{i,k}}}^{\max}$ ) to avoid operational problems.

$$TCUIN = Tcin_1 \quad (11)$$

$$T_{cout_{i,k}} < \Omega_{T_{cout_{i,k}}}^{\max}, \quad i \in HP, k \in ST \quad (12)$$

To ensure a monotonically decrement for the temperatures through the stages of the superstructure, the next constraints are included. It is necessary to specify that the temperature of each hot process stream in the stage  $k$  must be lower or equal than the temperature of each hot process stream in the stage  $k+1$ ,

$$Th_{i,k} \leq Th_{i,k+1}, \quad k \in ST, i \in HP \quad (13)$$

The inlet cooling medium temperature to stage  $k$  must be lower or equal than the outlet cooling medium temperature in the match  $i, k$ ,

$$Tcin_k \leq T_{cout_{i,k}}, \quad k \in ST, i \in HP \quad (14)$$

The temperature inlet cooling medium to the cooling network must be less or equal than the inlet cooling medium temperature in the stage  $k$ ,

$$TCU_{in} \leq Tcin_k, \quad k \in ST, \forall k > 1 \quad (15)$$

Finally, the outlet cooling medium temperature in the match  $i,k$  should be lower or equal than the outlet cooling medium temperature in the match  $i,k+1$ ,

$$T_{cout_{i,k}} \leq T_{cout_{i,k+1}}, \quad k \in ST, i \in HP \quad (16)$$

Logic constraints and binary variables are used to determine the existence of the heat exchangers between the hot process stream  $i$  in the stage  $k$  with the cooling medium. These constraints are stated as follow,

$$q_{i,k} - \Omega_{q_{i,k}}^{\max} z_{i,k}^1 \leq 0, \quad i \in HP, k \in ST \quad (17)$$

Here  $\Omega_{q_{i,k}}^{\max}$  is an upper limit equals to the heat content of the hot process stream  $i$  and  $z_{i,k}^1$  is a binary variable used to determine the existence of the heat exchangers.

Because the area requirements for each match ( $A_{i,k}$ ) are included in the objective function, the temperature differences should be calculated. The model uses a pair of variables for the temperature difference in the cold side ( $dtfri_{i,k}$ ) and the hot side ( $dtcal_{i,k}$ ) of each match. In addition, binary variables are used to ensure positive temperature differences and greater than a given value of  $\Delta T_{MIN}$  when a match exists.

$$dtcal_{i,k} \leq Th_{i,k+1} - T_{cout_{i,k}} + \Gamma_i (1 - z_{i,k}^1), \quad k \in ST, i \in HP \quad (18)$$

$$dtfri_{i,k} \leq Th_{i,k} - Tcin_k + \Gamma_i(1 - z_{i,k}^1), \quad k \in ST, i \in HP \quad (19)$$

$$dtcal_{i,k} \geq \Delta T_{MIN}, \quad k \in ST, i \in HP \quad (20)$$

$$dtfri_{i,k} \geq \Delta T_{MIN}, \quad k \in ST, i \in HP \quad (21)$$

where  $\Gamma_i$  is an upper limit for the temperature difference for the hot process stream  $i$ . The value of  $\Gamma_i$  is a constant known previous to the optimization and it is given by,

$$\Gamma_i = \max(0, THIN_i - TCUIN, -THOUT_i - TCU_{in}, THIN_i - Tcout_{max}, THOUT_i - Tcout_{max}) \quad (22)$$

Equations (18) and (19) are written as inequalities because the heat exchanger costs decrease when the temperature differences increase. Note that the use of binary variables allows the feasibility because if the match does not exist, the parameter  $\Gamma_i$  ensures that these restrictions are met. When a heat exchanger for the hot process stream  $i$  exists at the stage  $k$ , the binary variable  $z_{i,k}^1$  is equal to one, then the constraint is applied and the temperature differences are properly calculated.

The flowrates ( $Fw_j$ ) and temperatures ( $Tw_j$ ) of the cooling water streams that are directed to the splitters at the inlet of the cooling tower network are determined in the last stage of the cooler network. It is important to note that a problem with  $NH$  hot process streams will have  $NH+1$  cooling water streams leaving the cooler network, because in addition to the flowrates of the cooling water for each match in the last stage it is generated an overall cooling water stream that results from combining the bypass cooling-water streams of the previous stages. Therefore, the value for the set of cooling water streams directed to the cooling tower network is  $NEF = NH + 1$ .

$$Fw_j = F_{i,k}, \quad k = NOK; j \neq NCP; j = i \quad (23)$$

$$Fw_j = \sum_{k \in ST} FO_k, \quad j = NCP \quad (24)$$

$$Tw_j = Tcout_{i,k}, \quad k = NOK; j \neq NCP; j = i \quad (25)$$

$$Tw_j Fw_j = \sum_{k \in ST} TO_k FO_k, \quad j = NCP \quad (26)$$

The outlet cooling water stream flowrate from the cooling network can be sent to each tower of the cooling tower network ( $Fw_{1,j,net}$ ) and/or directed to the end of the cooling tower network ( $Fw_{2,j}$ ),

$$Fw_j = \sum_{nct \in NCT} Fw_{1,j,nct} + Fw_{2,j}, \quad j \in NEF \quad (27)$$

the inlet water flowrate ( $Fw_{in,net}$ ) and temperature ( $Tw_{in,net}$ ) to the cooling towers are generated by the mix of the portions of cooling medium streams sent to the cooling towers and the flowrate from the cooling tower ( $FTT_{net-1,net}$ ),

$$Fw_{in,nct} = \sum_{j \in NEF} Fw_{1,j,nct} + FTT_{net-1,net}, \quad nct \in NCT \quad (28)$$



$$Tw_{in,nct}Fw_{in,nct} = \sum_{j \in NEF} Tw_j Fw_{1,j,nct} + Tw_{out,nct-1} FTT_{nct-1,nct}, \quad nct \in NCT \quad (29)$$

There is a loss of water in the cooling towers by evaporation ( $Fw_{ev,net}$ ) and the drift of water by the air flowrate ( $Fw_{d,net}$ ). The water evaporated is obtained from the following relationship:

$$Fw_{ev,nct} = Fa_{nct} (w_{out,nct} - w_{in,nct}), \quad nct \in NCT \quad (30)$$

while the drift loss of water is 0.2 percent of the inlet water flowrate to the cooling tower (Kemmer, 1988):

$$Fw_{d,nct} = 0.002Fw_{in,nct}, \quad nct \in NCT \quad (31)$$

Thus, for each cooling tower, the outlet water flowrate is given by the following expression:

$$Fw_{out,nct} = Fw_{in,nct} - Fw_{ev,nct} - Fw_{d,nct} \quad (32)$$

and the outlet cooling tower flowrate ( $Fw_{out,net}$ ) can be split and sent to the next cooling tower and/or to the end of the cooling tower network ( $Fws_{net}$ ),

$$Fw_{out,nct} = FTT_{nct,nct+1} + Fws_{nct}, \quad nct \in NCT \quad (33)$$

The flowrate ( $Fw_{dis}$ ) and temperature ( $Tw_{dis}$ ) for the end of the cooling tower network are the sum of the bypassed flowrates of the cooling medium streams and the outlet cooling tower flowrates,

$$Fw_{dis} = \sum_{j \in NEF} Fw_{2,j} + \sum_{nct \in NCT} Fws_{nct} \quad (34)$$

$$Tw_{dis}Fw_{dis} = \sum_{j \in NEF} Tw_j Fw_{2,j} + \sum_{nct \in NCT} Tw_{out,nct} Fws_{nct} \quad (35)$$

To avoid salts deposition, usually a little blowdown flowrate ( $Fw_b$ ) is applied over the water flowrate treated in the cooling tower network, which can be determined by,

$$Fw_b = \frac{Fw_r}{N_{CYCLES}} - \sum_{nct \in NCT} Fw_{d,nct} \quad (36)$$

Note that the last term is the total drift loss of water by the air in the cooling tower network. Also,  $Fw_r$  is the makeup flowrate and  $N_{CYCLES}$  is the number of concentration cycles. Then, the outlet flowrate of the cooling tower network ( $Fw_{ctn}$ ) is equal to the flowrate at the end of cooling network minus the blowdown,

$$Fw_{ctn} = Fw_{dis} - Fw_b \quad (37)$$

but the cooling medium temperature in the outlet of cooling network ( $Tw_{ctn}$ ) is,

$$Tw_{ctn} = Tw_{dis} \quad (38)$$



To maintain the cooling medium flowrate constant in the cooling system, it is necessary a makeup flowrate to replace the lost water by evaporation, drift and blowdown,

$$Fw_r = \sum_{nct \in NCT} Fw_{ev,nct} + \sum_{nct \in NCT} Fw_{d,nct} + Fw_b \quad (39)$$

Note that the total water evaporated and drift loss of water in the cooling tower network are considered. The flowrate required by the cooling network ( $FCU_{in}$ ) is determined as follow:

$$FCU_{in} = Fw_{ctn} + Fw_r \quad (40)$$

and the inlet cooling medium temperature to the cooling network is obtained from,

$$TCU_{in} FCU_{in} = Tw_{ctn} Fw_{ctn} + Tw_r Fw_r \quad (41)$$

To avoid mathematical problems, the recycle between cooling towers is not considered; therefore, it is necessary to specify that the recycle in the same cooling tower and from a cooling tower of the stage  $nct$  to the cooling tower of stage  $nct-1$  is zero,

$$FTT_{nct1,nct} = 0, \quad nct, nct1 \in NCT; nct1 \leq nct \quad (42)$$

The following relationships are used to model the design equations for the cooling towers to satisfy the cooling requirements for the cooling network. First, the following disjunction is used to determine the existence of a cooling tower and to apply the corresponding design equations,

$$\left[ \begin{array}{c} z_{nct}^2 \\ \Psi_{nct} \leq \Psi_{nct}^{\max} \\ \Psi_{nct} \geq \Psi_{nct}^{\min} \end{array} \right] \vee \left[ \begin{array}{c} -z_{nct}^2 \\ \Psi_{nct} = 0 \end{array} \right], \quad nct \in NCT$$

Here  $Z_{NCT}^2$  is a Boolean variable used to determine the existence of the cooling towers,  $\Psi_{nct}^{\max}$  is an upper limit for the variables,  $\Psi_{nct}^{\min}$  is a lower limit for the variables,  $\Psi_{nct}$  is any design variable of the cooling tower like inlet flowrate, mass air flowrate, Merkel number, and others. For example, when inlet flowrate to the cooling tower is used, previous disjunction for the inlet flowrate to the cooling tower is reformulated as follows:

$$Fw_{in,nct} - \Omega_{Fw_{in,nct}}^{\max} z_{nct}^1 \leq 0, \quad nct \in NCT \quad (43)$$

$$Fw_{in,nct} - \Omega_{Fw_{in,nct}}^{\min} z_{nct}^1 \geq 0, \quad nct \in NCT \quad (44)$$

where  $\Omega_{Fw_{in,nct}}^{\max}$  and  $\Omega_{Fw_{in,nct}}^{\min}$  are upper and lower limits for the inlet flowrate to the cooling tower, respectively. Notice that this reformulation is applied to each design variable of the cooling towers. The detailed thermal-hydraulic design of cooling towers is modeled with Merkel's method (Merkel, 1926). The required Merkel's number in each cooling tower,  $Me_{nct}$ , is calculated using the four-point Chebyshev integration technique (Mohiudding and Kant, 1996),

$$Me_{nct} = 0.25CP_{cu} (Tw_{in,nct} - Tw_{out,nct}) \sum_{n=1}^4 1/\Delta h_{n,nct}; \quad nct \in NCT \quad (45)$$

where  $n$  is the temperature-increment index. For each temperature increment, the local enthalpy difference ( $\Delta h_{n,nct}$ ) is calculated as follows

$$\Delta h_{n,nct} = hsa_{n,nct} - ha_{n,nct}, \quad n = 1, \dots, 4; nct \in NCT \quad (46)$$

and the algebraic equations to calculate the enthalpy of bulk air-water vapor mixture and the water temperature corresponding to each Chebyshev point are given by,

$$ha_{n,nct} = ha_{in,nct} + \frac{CP_{cu} Fw_{in,nct}}{Fa_{nct}} (Tw_{n,nct} - Tw_{out,nct}), \quad n = 1, \dots, 4; nct \in NCT \quad (47)$$

$$Tw_{n,nct} = Tw_{out,nct} + TCH_n (Tw_{in,nct} - Tw_{out,nct}), \quad n = 1, \dots, 4; nct \in NCT \quad (48)$$

where  $TCH_n$  is a constant that represents the Chebyshev points ( $TCH_1=0.1$ ,  $TCH_2=0.4$ ,  $TCH_3=0.6$  and  $TCH_4=0.9$ ). The heat and mass transfer characteristics for a particular type of packing are given by the available Merkel number correlation developed by Kloppers and Kröger (2005):

$$Me_{nct} = c_{1,nct} \left( \frac{Fw_{in,nct}}{A_{fr,nct}} \right)^{c_{2,nct}} \left( \frac{Fa_{nct}}{A_{fr,nct}} \right)^{c_{3,nct}} (L_{fi,nct})^{1+c_{4,nct}} (Tw_{in,nct})^{c_{5,nct}}, \quad nct \in NCT \quad (49)$$

To calculate the available Merkel number, the following disjunction is used through the Boolean variable  $Y_{nct}^e$ :

$$\left[ \begin{array}{c} Y_{nct}^1 \\ \text{(splash fill)} \\ c_{l,nct} = c_{l,nct}^1, \quad l = 1, \dots, 5 \end{array} \right] \vee \left[ \begin{array}{c} Y_{nct}^2 \\ \text{(trickle fill)} \\ c_{l,nct} = c_{l,nct}^2, \quad l = 1, \dots, 5 \end{array} \right] \vee \left[ \begin{array}{c} Y_{nct}^3 \\ \text{(film fill)} \\ c_{l,nct} = c_{l,nct}^3, \quad l = 1, \dots, 5 \end{array} \right], \quad nct \in NCT$$

Notice that only when the cooling tower  $ntc$  exists, its design variables are calculated and only one fill type must be selected; therefore, the sum of the binary variables referred to the different fill types must be equal to the binary variable that determines the existence of the cooling towers. Then, this disjunction can be described with the convex hull reformulation (Vicchietti et al., 2003) by the following set of algebraic equations:

$$y_{nct}^1 + y_{nct}^2 + y_{nct}^3 = z_{nct}^2, \quad nct \in NCT \quad (50)$$

$$c_{l,nct} = c_{l,nct}^1 + c_{l,nct}^2 + c_{l,nct}^3, \quad l = 1, \dots, 5; nct \in NCT \quad (51)$$

$$c_{l,nct}^e = b_l^e y_{nct}^e, \quad e = 1, \dots, 3; l = 1, \dots, 5; nct \in NCT \quad (52)$$

Values for the coefficients  $b_l^e$  for the splash, trickle, and film type of fills are given in Table 1 (Kloppers and Kröger, 2005); these values can be used to determine the fill performance. For

each type of packing, the loss coefficient correlation can be expressed in the following form (Kloppers and Kröger, 2003):

$$K_{fi,nct} = \left[ d_{1,nct} \left( \frac{Fw_{in,nct}}{A_{fr,nct}} \right)^{d_{2,nct}} \left( \frac{Fa_{nct}}{A_{fr,nct}} \right)^{d_{3,nct}} + d_{4,nct} \left( \frac{Fw_{in,nct}}{A_{fr,nct}} \right)^{d_{5,nct}} \left( \frac{Fa_{nct}}{A_{fr,nct}} \right)^{d_{6,nct}} \right] L_{fi,nct}, \quad nct \in NCTa \quad (53)$$

The corresponding disjunction is given by,

$$\left[ \begin{array}{c} Y_{nct}^1 \\ \text{(splash fill)} \\ d_{m,nct} = d_{m,nct}^1, m = 1, \dots, 6 \end{array} \right] \vee \left[ \begin{array}{c} Y_{nct}^2 \\ \text{(trickle fill)} \\ d_{m,nct} = d_{m,nct}^2, m = 1, \dots, 6 \end{array} \right] \vee \left[ \begin{array}{c} Y_{nct}^3 \\ \text{(film fill)} \\ d_{m,nct} = d_{m,nct}^3, m = 1, \dots, 6 \end{array} \right], \quad nct \in NCT$$

Using the convex hull reformulation (Vicchiotti et al., 2003), previous disjunction is modeled as follows:

$$d_{m,nct} = d_{m,nct}^1 + d_{m,nct}^2 + d_{m,nct}^3, \quad m = 1, \dots, 6; nct \in NCT \quad (54)$$

$$d_{m,nct}^e = c_m^e y_{nct}^e, \quad e = 1, \dots, 3; m = 1, \dots, 6; nct \in NCT \quad (55)$$

	$b_i^e$		
	e=1 (splash fill)	e=2 (trickle fill)	e=3 (film fill)
1	0.249013	1.930306	1.019766
2	-0.464089	-0.568230	-0.432896
3	0.653578	0.641400	0.782744
4	0	-0.352377	-0.292870
5	0	-0.178670	0

Table 1. Constants for transfer coefficients

Values for the coefficients  $c_m^e$  for the three fills are given in Table 2 (Kloppers and Kröger, 2003). These values were obtained experimentally and they can be used in the model presented in this chapter. The total pressure drop of the air stream is given by (Serna-González et al., 2010),

$$\Delta P_{t,nct} = 0.8335 \frac{Fav_{av,nct}^2}{\rho_{av,nct} A_{fr,nct}^2} (K_{fi,nct} L_{fi,nct} + 6.5), \quad nct \in NCT \quad (56)$$

where  $Fav_{m,nct}$  is the arithmetic mean air-vapor flowrate through the fill in each cooling tower,

$$Fav_{av,nct} = \frac{Fav_{in,nct} + Fav_{out,nct}}{2}; \quad nct \in NCT \quad (57)$$

and  $\rho_{av,nct}$  is the harmonic mean density of the moist air through the fill calculated as:

$$\rho_{av,nct} = 1 / \left( 1/\rho_{in,nct} + 1/\rho_{out,nct} \right), \quad nct \in NCT \quad (58)$$

m	$c_m^e$		
	e=1 (splash fill)	e=2 (trickle fill)	e=3 (film fill)
1	3.179688	7.047319	3.897830
2	1.083916	0.812454	0.777271
3	-1.965418	-1.143846	-2.114727
4	0.639088	2.677231	15.327472
5	0.684936	0.294827	0.215975
6	0.642767	1.018498	0.079696

Table 2. Constants for loss coefficients

The air-vapor flow at the fill inlet and outlet  $Fav_{in,nct}$  and  $Fav_{out,nct}$  are calculated as follows:

$$Fav_{in,nct} = Fa_{nct} + w_{in,nct}Fa_{nct}, \quad nct \in NCT \quad (59)$$

$$Fav_{out,nct} = Fa_{nct} + w_{out,nct}Fa_{nct}, \quad nct \in NCT \quad (60)$$

where  $w_{in,nct}$  is the humidity (mass fraction) of the inlet air, and  $w_{out,nct}$  is the humidity of the outlet air. The required power for the cooling tower fan is given by:

$$PC_{f,nct} = \frac{Fav_{in,nct}\Delta P_{t,nct}}{\rho_{in,nct}\eta_{f,nct}}; \quad nct \in NCT \quad (61)$$

where  $\eta_{f,nct}$  is the fan efficiency. The power consumption for the water pump may be expressed as (Leeper, 1981):

$$PC_p = \left( \frac{g}{gc} \right) \left[ \frac{FCU_{in}(L_{fi,t} + 3.048)}{\eta_p} \right] \quad (62)$$

where  $\eta_p$  is the pump efficiency. As can be seen in the equation (62), the power consumption for the water pump depends on the total fill height ( $L_{fi,t}$ ), which depends on the arrangement of the cooling tower network (i.e., parallel ( $L_{fi,t,pl}$ ) or series ( $L_{fi,t,s}$ ));

$$L_{fi,t} = L_{fi,t,pl} + L_{fi,t,s} \quad (63)$$

If the arrangement is in parallel, the total fill height is equal to the fill height of the tallest cooling tower, but if the arrangement is in series, the total fill height is the sum of the cooling towers used in the cooling tower network. This decision can be represented by the next disjunction,

$$\left[ \begin{array}{c} z_{nct,nct}^3 \\ FTT_{nct,nct} \leq FTT_{nct,nct}^{\max} \\ FTT_{nct,nct} \geq FTT_{nct,nct}^{\min} \end{array} \right] \vee \left[ \begin{array}{c} -z_{nct,nct}^3 \\ FTT_{nct,nct} = 0 \end{array} \right]$$

This last disjunction determines the existence of flowrates between cooling towers. Following disjunction is used to activate the arrangement in series,

$$\left[ \begin{array}{c} z_s^4 \\ \sum_{nct} \sum_{nct} z_{nct,nct}^3 \geq \Phi \sum_{nct} \sum_{nct} z_{nct,nct}^3 \\ L_{fi,t,s} = \sum_{nct \in NCT} L_{fi,s,nct} \\ \Phi \sum_{nct} \sum_{nct} z_{nct,nct}^3 = 1 \end{array} \right] \vee \left[ \begin{array}{c} -z_s^4 \\ \sum_{nct} \sum_{nct} z_{nct,nct}^3 = 0 \\ L_{fi,t,s} = 0 \end{array} \right]$$

here  $\Phi \sum_{nct} \sum_{nct} z_{nct,nct}^3$  is the minimum number of interconnections between cooling towers when a series arrangement is used. The reformulation for this disjunction is the following:

$$\sum_{nct} \sum_{nct} z_{nct,nct}^{3,1} \geq \Phi \sum_{nct} z_s^{4,1} \quad (64)$$

$$L_{fi,nct,s} \leq \Omega_{L_{fi}}^{\max} z_s^4 \quad (65)$$

$$L_{fi,t,s} = \sum_{nct \in NCT} L_{fi,nct,s} \quad (66)$$

If a series arrangement does not exist, then a parallel arrangement is used. In this case, the total fill height is calculated using the next disjunction based on the Boolean variable  $z_p^{5,nct}$ , which shows all possible combination to select the biggest fill height from the total possible cooling towers that can be used in the cooling tower network:

$$\left[ \begin{array}{c} z_{pl}^{5,1} \\ L_{fi,nct=1,pl} \geq L_{fi,nct \neq 1,pl} \\ L_{fi,t,pl} = L_{fi,nct=1,p} \end{array} \right] \vee \left[ \begin{array}{c} z_{pl}^{5,2} \\ L_{fi,nct=2,pl} \geq L_{fi,nct \neq 2,pl} \\ L_{fi,t,pl} = L_{fi,nct=2,p} \end{array} \right] \dots \vee \left[ \begin{array}{c} z_{pl}^{5,LCT} \\ L_{fi,nct=LCT,pl} \geq L_{fi,nct \neq LCT,pl} \\ L_{fi,t,pl} = L_{fi,nct=LCT,pl} \end{array} \right]$$

The reformulation for the disjunction is:

$$z_{pl}^{5,1} + z_{pl}^{5,2} + \dots + z_{pl}^{5,LCT} = (1 - z_s^4) \quad (67)$$

Notice that when  $z_s^4$  is activated, then any binary variable  $z_{pl}^{5,nct}$  can be activated, but if  $z_s^4$  is not activated, only one binary variable  $z_{pl}^{5,nct}$  must be activated, and it must represent the tallest fill. The rest of the reformulation is:

$$L_{fi,nct=1,pl} = L_{fi,nct=1,pl}^1 + L_{fi,nct=1,pl}^2 + \dots + L_{fi,nct=1,pl}^{LCT} \quad (68)$$

$$L_{fi,nct=2,pl} = L_{fi,nct=2,pl}^1 + L_{fi,nct=2,pl}^2 + \dots + L_{fi,nct=2,pl}^{LCT} \quad (69)$$

$$L_{fi,nct=LCT,pl} = L_{fi,nct=LCT,pl}^1 + L_{fi,nct=LCT,pl}^2 + \dots + L_{fi,nct=LCT,pl}^{LCT} \quad (70)$$

$$L_{fi,t,pl} = L_{fi,t,pl}^1 + L_{fi,t,pl}^2 + \dots + L_{fi,t,pl}^{LCT} \quad (71)$$

$$\begin{aligned} L_{fi,nct=1,pl}^1 &\geq L_{fi,nct \neq 1,pl}^1 \\ L_{fi,nct=2,pl}^2 &\geq L_{fi,nct \neq 2,pl}^2 \\ &\vdots \end{aligned} \quad (72)$$

$$L_{fi,nct=LCT,p}^{LCT} \geq L_{fi,nct \neq LCT,pl}^{LCT}$$

$$\begin{aligned} L_{fi,t,pl}^1 &= L_{fi,nct=1,pl}^1 \\ L_{fi,t,pl}^2 &= L_{fi,nct=2,pl}^2 \\ &\vdots \end{aligned} \quad (73)$$

$$L_{fi,t,pl}^{LCT} = L_{fi,nct=NCT,pl}^{LCT}$$

$$\begin{aligned} L_{fi,nct=1,pl}^1 &\leq \Omega_{L_{fi,nct}}^{\max} z_{pl}^{5,1} \\ L_{fi,nct=1,pl}^2 &\leq \Omega_{L_{fi,nct}}^{\max} z_{pl}^{5,2} \\ &\vdots \end{aligned} \quad (74)$$

$$L_{fi,nct=1,pl}^{LCT} \leq \Omega_{L_{fi,nct}}^{\max} z_{pl}^{5,LCT}$$

$$\begin{aligned} L_{fi,nct=2,pl}^1 &\leq \Omega_{L_{fi,nct}}^{\max} z_{pl}^{5,1} \\ L_{fi,nct=2,pl}^2 &\leq \Omega_{L_{fi,nct}}^{\max} z_{pl}^{5,2} \\ &\vdots \end{aligned} \quad (75)$$

$$L_{fi,nct=2,pl}^{NCT} \leq \Omega_{L_{fi,nct}}^{\max} z_{pl}^{5,LCT}$$

$$\begin{aligned} L_{fi,nct=LCT,pl}^1 &\leq \Omega_{L_{fi,nct}}^{\max} z_{pl}^{5,1} \\ L_{fi,nct=LCT,p}^2 &\leq \Omega_{L_{fi,nct}}^{\max} z_{pl}^{5,2} \\ &\vdots \end{aligned} \quad (76)$$

$$L_{fi,nct=LCT,pl}^{LCT} \leq \Omega_{L_{fi,nct}}^{\max} z_{pl}^{5,LCT}$$

Finally, an additional equation is necessary to specify the fill height of each cooling tower depending of the type of arrangement,

$$L_{fi,nct} = L_{fi,nct,pl} + L_{fi,nct,s}, \quad nct \in NCT \quad (77)$$

According to the thermodynamic, the outlet water temperature in the cooling tower must be lower than the lowest outlet process stream of the cooling network and greater than the inlet wet bulb temperature; and the inlet water temperature in the cooling tower must be lower than the hottest inlet process stream in the cooling network. Additionally, to avoid the fouling of the pipes, 50°C usually are specified as the maximum limit for the inlet water temperature to the cooling tower (Serna-González et al., 2010),

$$Tw_{out,nct} \geq TWB_{in,nct} + 2.8, \quad nct \in NCT \quad (78)$$

$$Tw_{out,nct} \leq TMPO - \Delta T_{MIN}, \quad nct \in NTC \quad (79)$$

$$Tw_{in,nct} \leq TMPI - \Delta T_{MIN}, \quad nct \in NTC \quad (80)$$

$$Tw_{in,nct} \leq 50^\circ C, \quad nct \in NTC \quad (81)$$

here  $TMPO$  is the inlet temperature of the coldest hot process streams,  $TMPI$  is the inlet temperature of the hottest hot process stream. The final set of temperature feasibility constraints arises from the fact that the water stream must be cooled and the air stream heated in the cooling towers,

$$Tw_{in,nct} > Tw_{out,nct}, \quad nct \in NTC \quad (82)$$

$$TA_{out,nct} > TA_{in,nct}, \quad nct \in NTC \quad (83)$$

The local driving force ( $h_{sa_{nct}} - h_{a_{nct}}$ ) must satisfy the following condition at any point in the cooling tower (Serna-González et al., 2010),

$$h_{sa_{nct}} - h_{a_{nct}} > 0 \quad n = 1, \dots, 4; \quad nct \in NTC \quad (84)$$

The maximum and minimum water and air loads in the cooling tower are determined by the range of test data used to develop the correlations for the loss and overall mass transfer coefficients for the fills. The constraints are (Kloppers and Kröger, 2003, 2005),

$$2.90 \leq Fw_{in,nct} / A_{fr,nct} \leq 5.96, \quad nct \in NTC \quad (85)$$

$$1.20 \leq Fa_{nct} / A_{fr,nct} \leq 4.25, \quad nct \in NTC \quad (86)$$

Although a cooling tower can be designed to operate at any feasible  $Fw_{in,nct} / Fa_{nct}$  ratio, Singham (1983) suggests the following limits:

$$0.5 \leq Fw_{in,nct} / Fa_{nct} \leq 2.5, \quad nct \in NTC \quad (87)$$

The flowrates of the streams leaving the splitters and the water flowrate to the cooling tower have the following limits:

$$0 \leq Fw_{1,j,nct} \leq Fw_j, \quad j \in NEF; nct \in NTC \quad (88)$$



$$0 \leq Fw_{2,j} \leq Fw_j \quad j \in NEF \quad (89)$$

The objective function is to minimize the total annual cost of cooling systems (*TACS*) that consists in the total annual cost of cooling network (*TACNC*), the total annual cost of cooling towers (*TACTC*) and the pumping cost (*PWC*),

$$TACS = TACNC + TACTC + PWC \quad (90)$$

$$PWC = H_Y ce PC_p \quad (91)$$

where  $H_Y$  is the yearly operating time and  $ce$  is the unitary cost of electricity. The total annual cost for the cooling network is formed by the annualized capital cost of heat exchangers (*CAPCNC*) and the cooling medium cost (*OPCNC*).

$$TACNC = CAPCNC + OPCNC \quad (92)$$

where the capital cooling network cost is obtained from the following expression,

$$CAPCNC = K_F \left[ \sum_{i \in HP} \sum_{k \in ST} CFHE_i z_{i,k} + \sum_{i \in HP} \sum_{k \in ST} CAHE_i A_{i,k}^\beta \right] \quad (93)$$

Here  $CFHE_i$  is the fixed cost for the heat exchanger  $i$ ,  $CAHE_i$  is the cost coefficient for the area of heat exchanger  $i$ ,  $K_F$  is the annualization factor, and  $\beta$  is the exponent for the capital cost function. The area for each match is calculated as follows,

$$A_{i,k} = q_{i,k} / (U_i \Delta TML_{i,k} + \delta) \quad (94)$$

$$U_i = 1 / (1/h_i + 1/h_{cu}) \quad (95)$$

where  $U_i$  is the overall heat-transfer coefficient,  $h_i$  and  $h_{cu}$  are the film heat transfer coefficients for hot process streams and cooling medium, respectively.  $\Delta TML_{i,k}$  is the mean logarithmic temperature difference in each match and  $\delta$  is a small parameter (i.e.,  $1 \times 10^{-6}$ ) used to avoid divisions by zero. The Chen (1987) approximation is used to estimate  $\Delta TML_{i,k}$ ,

$$\Delta TML_{i,k} = \left[ (dtcal_{i,k})(dtfri_{i,k}) \left( (dtcal_{i,k} + dtfri_{i,k}) / 2 \right) \right]^{1/3} \quad (96)$$

In addition, the operational cost for the cooling network is generated by the makeup flowrate used to replace the lost of water in the cooling towers network,

$$OPCNC = CUw H_Y Fw_r \quad (97)$$

where  $CUw$  is the unitary cost for the cooling medium. The total annual cost of cooling towers network involves the investment cost for the cooling towers (*CAPTNC*) as well as the operational cost (*OPTNC*) by the air fan power of the cooling towers. The investment cost for the cooling towers is represented by a nonlinear fixed charge expression of the form (Kintner-Meyer and Emery, 1995):

$$CAPTNC = K_F \sum_{nct \in NCT} \left[ C_{CTF} z_{nct}^2 + CCTV_{nct} A_{fr,nct} L_{fi,nct} + C_{CTMA} F a_{nct} \right] \quad (98)$$

where  $C_{CTF}$  is the fixed charge associated with the cooling towers,  $CCTV_{nct}$  is the incremental cooling towers cost based on the tower fill volume, and  $C_{CTMA}$  is the incremental cooling towers cost based on air mass flowrate. The cost coefficient  $CCTV_{nct}$  depends on the type of packing. To implement the discrete choice for the type of packing, the Boolean variable  $Y_{nct}^e$  is used as part of the following disjunction,

$$\left[ \begin{array}{c} Y_{nct}^1 \\ \text{(splash fill)} \\ CCTV_{nct} = CCTV_{nct}^1 \end{array} \right] \vee \left[ \begin{array}{c} Y_{nct}^2 \\ \text{(trickle fill)} \\ CCTV_{nct} = CCTV_{nct}^2 \end{array} \right] \vee \left[ \begin{array}{c} Y_{nct}^3 \\ \text{(film fill)} \\ CCTV_{nct} = CCTV_{nct}^3 \end{array} \right]$$

This disjunction is algebraically reformulated as:

$$CCTV_{nct} = CCTV_{nct}^1 + CCTV_{nct}^2 + CCTV_{nct}^3, \quad nct \in NCT \quad (99)$$

$$CCTV_{nct}^e = a^e y_{nct}^e, \quad e = 1, \dots, 3, nct \in NCT \quad (100)$$

where the parameters  $a^e$  are 2,006.6, 1,812.25 and 1,606.15 for the splash, trickle, and film types of fill, respectively. Note that the investment cost expression properly reflects the influence of the type of packing, the air mass flowrate ( $F a_{nct}$ ) and basic geometric parameters, such as height ( $L_{fi,nct}$ ) and area ( $A_{fi,nct}$ ) for each tower packing. The electricity cost needed to operate the air fan and the water pump of the cooling tower is calculated using the following expression:

$$OPTNC = H_{Yce} \sum_{nct=1} PC_{f,nct} \quad (101)$$

This section shows the physical properties that appear in the proposed model, and the property correlations used are the following. For the enthalpy of the air entering the tower (Serna-González et al., 2010):

$$ha_{in} = -6.4 + 0.86582 * TWB_{in} + 15.7154 \exp(0.0544 * TWB_{in}) \quad (102)$$

For the enthalpy of saturated air-water vapor mixtures (Serna-González et al., 2010):

$$hsa_i = -6.3889 + 0.86582 * Tw_i + 15.7154 \exp(0.054398 * Tw_i), \quad i = 1, \dots, 4 \quad (103)$$

For the mass-fraction humidity of the air stream at the tower inlet (Kröger, 2004):

$$w_{in} = \left( \frac{2501.6 - 2.3263 (TWB_{in})}{2501.6 + 1.8577 (TA_{in}) - 4.184 (TWB_{in})} \right) \left( \frac{0.62509 (PV_{WB,in})}{P_t - 1.005 (PV_{WB,in})} \right) - \left( \frac{1.00416 (TA_{in} - TWB_{in})}{2501.6 + 1.8577 (TA_{in}) - 4.184 (TWB_{in})} \right) \quad (104)$$

where  $PV_{WB,in}$  is calculated from Equation (115) and evaluated at  $T = TWB_{in}$ . For the mass-fraction humidity of the saturated air stream at the cooling tower exit (Kröger, 2004):

$$w_{out} = \frac{0.62509PV_{out}}{P_t - 1.005PV_{out}} \quad (105)$$

where  $PV_{out}$  is the vapor pressure estimated with Equation (115) evaluated at  $T = TA_{out}$ , and  $P_t$  is the total pressure in Pa. Equation (115) was proposed by Hyland and Wexler (1983) and is valid in the range of temperature of 273.15 K to 473.15 K,

$$\ln(PV) = \sum_{n=-1}^3 c_n T^n + 6.5459673 \ln(T) \quad (106)$$

$PV$  is the vapor pressure in Pa,  $T$  is the absolute temperature in Kelvin, and the constants have the following values:  $c_{-1} = 5.8002206 \times 10^3$ ,  $c_0 = 1.3914993$ ,  $c_1 = -4.8640239 \times 10^{-3}$ ,  $c_2 = 4.1764768 \times 10^{-5}$  and  $c_3 = -1.4452093 \times 10^{-7}$ . For the outlet air temperature, Serna-González et al. (2010) proposed:

$$hsa_{out} + 6.38887667 - 0.86581791 * TA_{out} - 15.7153617 \exp(0.05439778 * TA_{out}) = 0 \quad (107)$$

For the density of the air-water mixture (Serna-González et al., 2010):

$$\rho = \frac{P_t}{287.08 T} \left[ 1 - \frac{w}{w + 0.62198} \right] [1 + w] \quad (108)$$

where  $P_t$  and  $T$  are expressed in Pa and K, respectively. The density of the inlet and outlet air are calculated from the last equation evaluated in  $T = TA_{in}$  and  $T = TA_{out}$  for  $w = w_{in}$  and  $w = w_{out}$ , respectively.

### 3. Results

Two examples are used to show the application of the proposed model. The first example involves three hot process streams and the second example involves five hot process streams. The data of these examples are presented in Table 3. In addition, the value of parameters  $ce$ ,  $H_Y$ ,  $K_F$ ,  $N_{CYCLES}$ ,  $\eta_f$ ,  $\eta_p$ ,  $P_t$ ,  $C_{CTF}$ ,  $C_{CTMA}$ ,  $CU_w$ ,  $CP_{cu}$ ,  $\beta$ ,  $CFHE$ ,  $CAHE$  are 0.076 \$US/kWh, 8000 hr/year, 0.2983 year<sup>-1</sup>, 4, 0.75, 0.6, 101325 Pa, 31185 \$US, 1097.5 \$US/(kg dry air/s),  $1.5449 \times 10^{-5}$  \$US/kg water, 4.193 kJ/kg°C, 1, 1000\$US, 700\$US/m<sup>2</sup>, respectively. For the Example 1, fresh water at 10 °C is available, while the fresh water is at 15°C for the Example 2.

For the Example 1, the optimal configuration given in Figure 3 shows a parallel arrangement for the cooling water network. Notice that one exchanger for each hot process stream is required. In addition, only one cooling tower was selected; consequently, the cooling tower network has a centralized system for cooling the hot process streams. The selected packing is the film type, and the lost water is 13.35 kg/s due to the evaporation lost (75%), and the drift and blowdown water (4.89% and 20.11%), while a 70.35% of the total power consumption is used by the fan and the rest is used by the pump (29.64%). The two above terms represent the total operation cost of the cooling system; therefore, both the evaporated water and the power fan are the main components for the cost in this example. Notice that

the water flowrate in the cooling network is 326.508 kg/s, but the reposition water only is 13.25 kg/s, which represents a save of freshwater of 95.94% respect to the case when is not used a cooling tower for thermal treatment of the cooling medium. The total annual cost is 468,719.906\$US/year. The contribution to total annual cost for the cost of cooling network is 66%, while for cooling tower network and the pump are 31% and 2.96%, respectively. These results are given in the Table 4.

Respect to the Example 2, Figure 4 presents the optimal configuration, which shows a parallel arrangement to the cooling water network, while the cooling towers network is formed by a distributed system composed by two cooling towers to treat the effluents from the cooling network and to meet the cooling requirements. The selected fill is the film type, and the lost water by evaporation, drift and blowdown represent a 74.99%, 3.94% and 21.07% of the total water lost, respectively. Respect the total power consumption in the cooling system, the fan demands a 65.37% and the pump use a 34.62% of the total cost. The economical results are given in the Table 4. The optimal cooling system shows costs for the cooling network, cooling tower and water pump equal to 61.21%, 36.34% and 2.44%, respectively, of the total annual cost. In addition, for the case that only one cooling tower is selected, the total annual cost is 143,4326.66\$US/year, which is 7% more expensive than the optimal configuration. The savings obtained are because the distributed system is able to find a better relationship between the capital cost and the operation cost, which depends of the range, inlet water flowrate and inlet air flowrate to the cooling tower network; therefore,

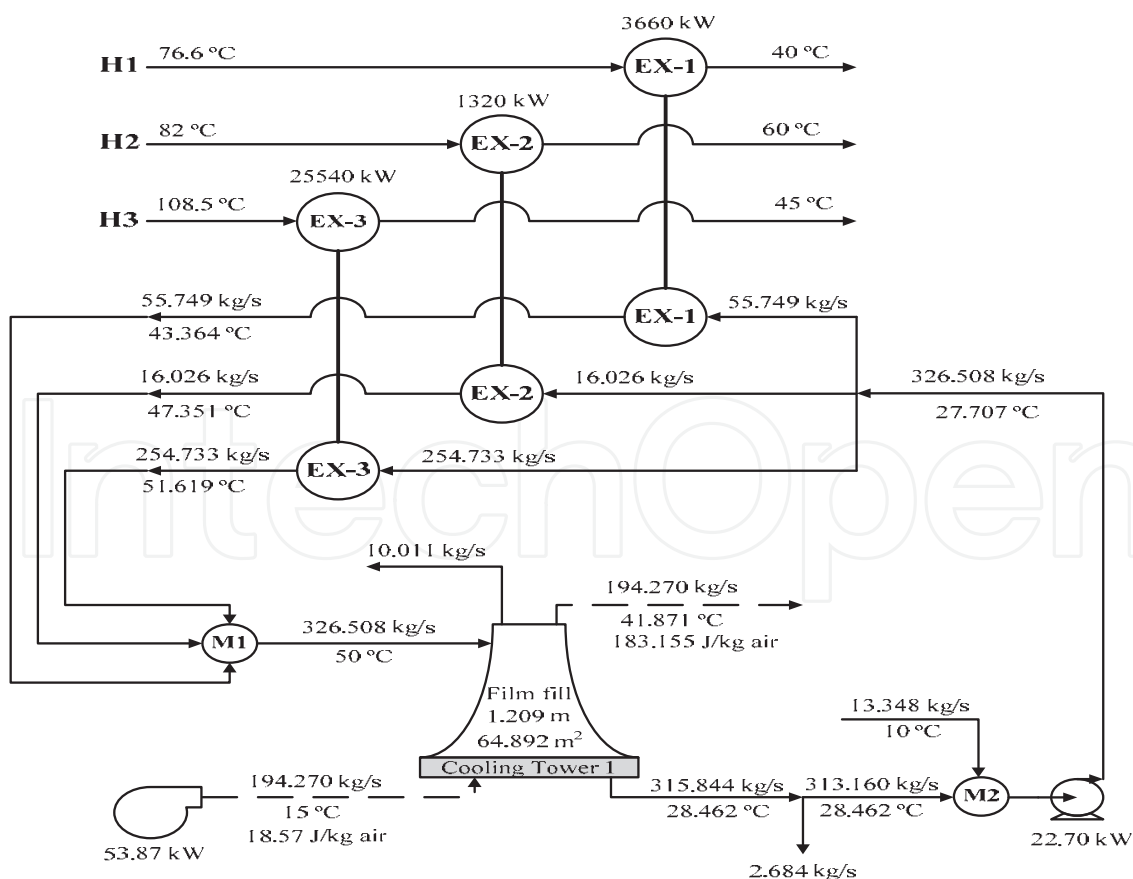

Fig. 3. Optimal configuration for the Example 1

in the distributed systems there are more options. In this case, the use of freshwater by the cooling network is reduced by 94.92% with the use of the cooling towers. Other advantage of use a distributed system is that depending of the problem data just one cooling tower could not meet with the operational and/or thermodynamic constraints and could be necessary to use more than one cooling tower.

Example 1					
Streams	THIN (°C)	THOUT (°C)	FCP (kW/°C)	Q (kW)	h (kW/m <sup>2</sup> °C)
1	40	76.6	100	3660	1.089
2	60	82	60	1320	0.845
3	45	108.5	400	25540	0.903
Example 2					
Streams	THIN (°C)	THOUT (°C)	FCP (kW/°C)	Q (kW)	h (kW/m <sup>2</sup> °C)
1	80	60	500	10000	1.089
2	75	28	100	4700	0.845
3	120	40	450	36000	0.903
4	90	45	300	13500	1.025
5	110	40	250	17500	0.75

Table 3. Data for examples

	Example 1	Example 2
TACS (US\$/year)	468,719.906	1,334,977.470
TACNC (US\$/year)	309,507.229	817,192.890
TACTC (US\$/year)	145,336.898	485,196.940
OPCNC (US\$/year)	6,131.013	16,588.250
OPTNC (US\$/year)	32,958.635	61,598.140
PWC (US\$/year)	13,875.780	32,587.640
CAPCNC (US\$/year)	303,376.216	800,604.640
CAPTNC (US\$/year)	112,378.262	181,000.330

Table 4. Results for examples

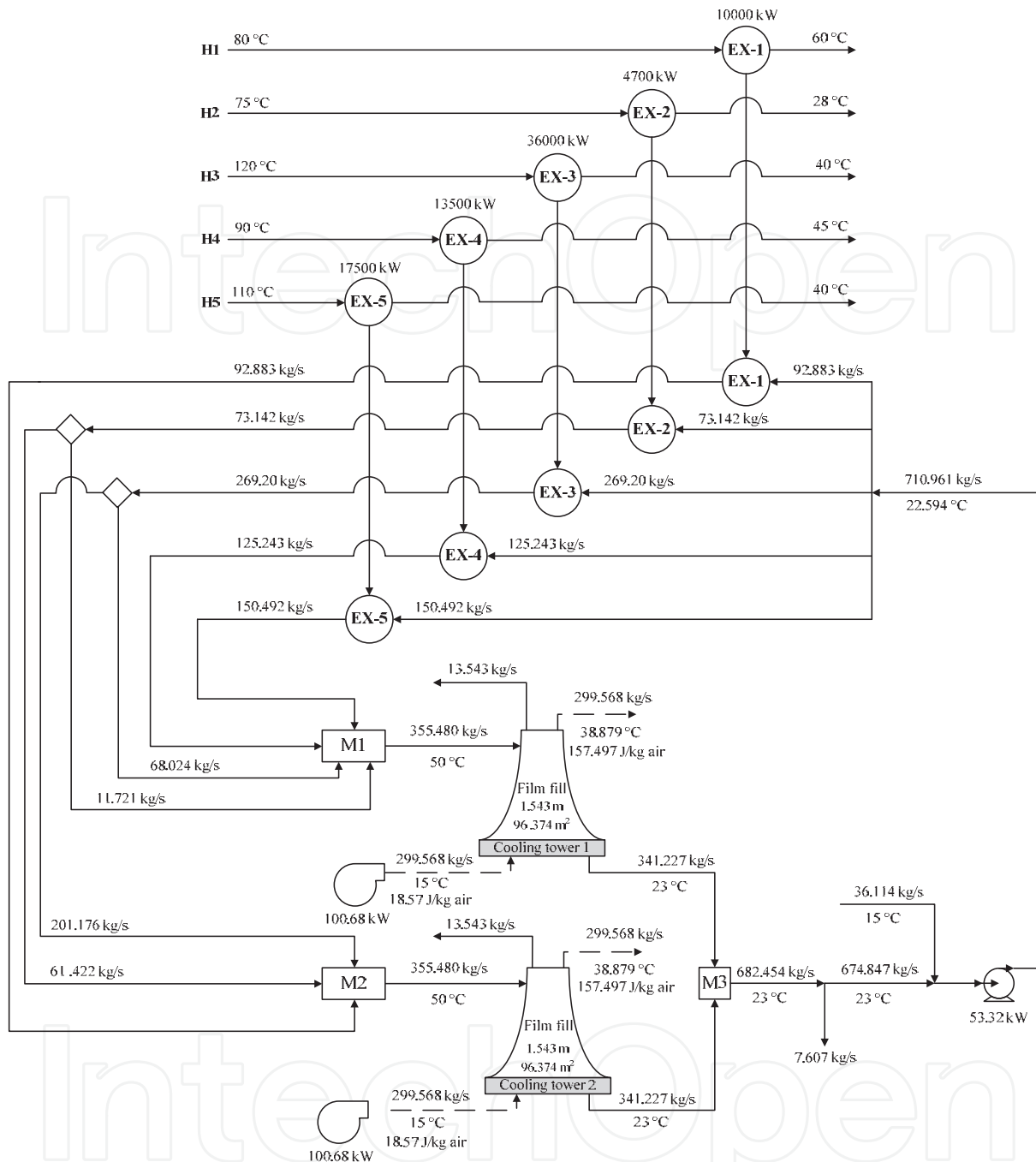

Fig. 4. Optimal configuration for the Example 2

#### 4. Conclusion

This chapter presents a new model for the detailed optimal design of re-circulating cooling water systems. The proposed formulation gives the system configuration with the minimum total annual cost. The model is based on a superstructure that considers simultaneously series and parallel arrangements for the cooling water network and cooling tower network, in which the cooling medium can be thermally treated using a distributed system. Significant savings were obtained with the distributed cooling systems for the



interconnection between cooling water network and cooling towers. Evaporation represents the main component for the lost of water (70-75%); while the drift and blowdown represent the 3-5% and 20-25%, respectively. The fan power consumption usually represents the 65-70% of the total power consumption in the cooling system; and the pump represents around the 30-35%. For re-circulating cooling water systems the costs of cooling network, cooling tower network and the water pump represent the 60-70%, 30-40% and 2-5% of the total cooling system cost, respectively. When re-circulating cooling water systems are used, the use of freshwater in the cooling network is significantly reduced (i.e., 95%).

## 5. References

- Chen, J.J. (1987). Letter to the Editors: Comments on improvement on a replacement for the logarithmic mean. *Chemical Engineering Science*, Vol.42, pp. 2488-2489.
- Feng, X.; Shen, R.J. & Wang, B. (2005). Recirculating cooling-water network with an intermediate cooling-water main. *Energy & Fuels*, Vol.19, No.4, pp. 1723-1728.
- Hyland, R.W. & Wexler, A. (1983). Formulation for the thermodynamic properties of the saturated phases of H<sub>2</sub>O from 173.15 K and 473.15 K. *ASHRAE Transactions*, Vol.89, No.2A, pp. 500-519.
- Kemmer, F.N. (1988). *The NALCO Water Handbook*, McGraw-Hill, New York, USA.
- Kim, J.K. & Smith, R. (2001). Cooling water system design. *Chemical Engineering Science*, Vol.56, No.12, pp. 3641-3658.
- Kintner-Meyer, M. & Emery, A.F. (1995). Cost-optimal design for cooling towers. *ASHRAE Journal*, Vol.37, No.4, pp. 46-55.
- Kloppers, J.C. & Kröger, D.G. (2003). Loss coefficient correlation for wet-cooling tower fills, *Applied Thermal Engineering*, Vol.23, No.17, pp. 2201-2211.
- Kloppers, J.C. & Kröger, D.G. (2005). Refinement of the transfer characteristic correlation of wet-cooling tower fills. *Heat Transfer Engineering*, Vol.26, No.4, pp. 35-41.
- Kröger, D.G. (2004). *Air-Cooled Heat Exchangers and Cooling Towers*, PenWell Corp., Tulsa, USA.
- Leeper, S.A. (1981). Wet cooling towers: rule-of-thumb design and simulation. *Report, U.S. Department of Energy*, 1981.
- Merkel, F. (1926). Verdunstungskühlung, *VDI Zeitschrift Deutscher Ingenieure*, Vol.70, pp. 123-128.
- Mohiudding, A.K.M. & Kant, K. (1996). Knowledge base for the systematic design of wet cooling towers. Part I: Selection and tower characteristics. *International Journal of Refrigeration*, Vol.19, No.1, pp. 43-51.
- Ponce-Ortega, J.M.; Serna-González, M. & Jiménez-Gutiérrez, A. (2007). MINLP synthesis of optimal cooling networks. *Chemical Engineering Science*, Vol.62, No.21, pp. 5728-5735.
- Serna-González, M.; Ponce-Ortega, J.M. & Jiménez-Gutiérrez, A. (2010). MINLP optimization of mechanical draft counter flow wet-cooling towers. *Chemical Engineering Research and Design*, Vol.88, No.5-6, pp. 614-625.
- Singham, J.R. (1983). *Heat Exchanger Design Handbook*, Hemisphere Publishing Corporation, New York, USA.
- Söylemez, M.S. (2001). On the optimum sizing of cooling towers. *Energy Conversion and Management*, Vol.42, No.7, pp. 783-789.



- Söylemez, M.S. (2004). On the optimum performance of forced draft counter flow cooling towers. *Energy Conversion and Management*, Vol.45, No.15-16, pp. 2335-2341.
- Vicchietti, A., Lee, S. & Grossmann, I.E. (2003). Modeling of discrete/continuous optimization problems characterization and formulation of disjunctions and their relaxations. *Computers and Chemical Engineering*, Vol.27, No.3, pp. 433-448.

IntechOpen

IntechOpen



## **Energy Management Systems**

Edited by Dr Giridhar Kini

ISBN 978-953-307-579-2

Hard cover, 274 pages

**Publisher** InTech

**Published online** 01, August, 2011

**Published in print edition** August, 2011

This book comprises of 13 chapters and is written by experts from industries, and academics from countries such as USA, Canada, Germany, India, Australia, Spain, Italy, Japan, Slovenia, Malaysia, Mexico, etc. This book covers many important aspects of energy management, forecasting, optimization methods and their applications in selected industrial, residential, generation system. This book also captures important aspects of smart grid and photovoltaic system. Some of the key features of books are as follows: Energy management methodology in industrial plant with a case study; Online energy system optimization modelling; Energy optimization case study; Energy demand analysis and forecast; Energy management in intelligent buildings; PV array energy yield case study of Slovenia; Optimal design of cooling water systems; Supercapacitor design methodology for transportation; Locomotive tractive energy resources management; Smart grid and dynamic power management.

### **How to reference**

In order to correctly reference this scholarly work, feel free to copy and paste the following:

Eusiel Rubio-Castro, José María Ponce-Ortega and Medardo Serna-González (2011). Optimal Design of Cooling Water Systems, Energy Management Systems, Dr Giridhar Kini (Ed.), ISBN: 978-953-307-579-2, InTech, Available from: <http://www.intechopen.com/books/energy-management-systems/optimal-design-of-cooling-water-systems>

**INTECH**  
open science | open minds

### **InTech Europe**

University Campus STeP Ri  
Slavka Krautzeka 83/A  
51000 Rijeka, Croatia  
Phone: +385 (51) 770 447  
Fax: +385 (51) 686 166  
[www.intechopen.com](http://www.intechopen.com)

### **InTech China**

Unit 405, Office Block, Hotel Equatorial Shanghai  
No.65, Yan An Road (West), Shanghai, 200040, China  
中国上海市延安西路65号上海国际贵都大饭店办公楼405单元  
Phone: +86-21-62489820  
Fax: +86-21-62489821

© 2011 The Author(s). Licensee IntechOpen. This chapter is distributed under the terms of the [Creative Commons Attribution-NonCommercial-ShareAlike-3.0 License](#), which permits use, distribution and reproduction for non-commercial purposes, provided the original is properly cited and derivative works building on this content are distributed under the same license.

IntechOpen

IntechOpen