

We are IntechOpen, the world's leading publisher of Open Access books Built by scientists, for scientists

4,800

Open access books available

122,000

International authors and editors

135M

Downloads

Our authors are among the

154

Countries delivered to

TOP 1%

most cited scientists

12.2%

Contributors from top 500 universities



WEB OF SCIENCE™

Selection of our books indexed in the Book Citation Index
in Web of Science™ Core Collection (BKCI)

Interested in publishing with us?
Contact book.department@intechopen.com

Numbers displayed above are based on latest data collected.
For more information visit www.intechopen.com



Production of Retroviral and Lentiviral Gene Therapy Vectors: Challenges in the Manufacturing of Lipid Enveloped Virus

Ana F. Rodrigues, Paula M. Alves and Ana S. Coroadinha
Instituto de Biologia Experimental e Tecnologia/ Instituto de Tecnologia Química e Biológica – Universidade Nova de Lisboa (IBET/ITQB-UNL)
Portugal

1. Introduction

Gamma-retroviral vectors, commonly designated retroviral vectors, were the first viral vector employed in Gene Therapy clinical trials in 1990 and are still one of the most used. More recently, the interest in lentiviral vectors, derived from complex retroviruses such as the human immunodeficiency virus (HIV), has been growing due to their ability to transduce non-dividing cells (Lewis et al. 1992; Naldini et al. 1996), an attribute that distinguishes them from other viral vectors, including their simple counterparts, gamma-retroviral vectors. Retroviral and lentiviral vectors most attractive features as gene transfer tools include the capacity for large genetic payload (up to 9 kb), minimal patient immune response, high transducing efficiency *in vivo* and *in vitro*, and the ability to permanently modify the genetic content of the target cell, sustaining a long-term expression of the delivered gene (Coroadinha et al. 2010; Schweizer and Merten 2010).

According to the most recent updates, retroviral and lentiviral vectors represent 23% of all the vector types and 33% of the viral vectors used in Gene Therapy clinical trials. Moreover, retroviral vectors are currently the blockbuster vectors for the treatment of monogenic and infectious diseases and gene marking clinical trials (Edelstein 2010).

Retroviruses are double stranded RNA enveloped viruses mainly characterized by the ability to “reverse-transcribe” their genome from RNA to DNA. Virions measure 100-120 nm in diameter and contain a dimeric genome of identical positive RNA strands complexed with the nucleocapsid (NC) proteins. The genome is enclosed in a proteic capsid (CA) that also contains enzymatic proteins, namely the reverse transcriptase (RT), the integrase (IN) and proteases (PR), required for viral infection. The matrix proteins (MA) form a layer outside the capsid core that interacts with the envelope, a lipid bilayer derived from the host cellular membrane, which surrounds the viral core particle (Coffin et al. 1997). Anchored on this bilayer, are the viral envelope glycoproteins (Env) responsible for recognizing specific receptors on the host cell and initiating the infection process. Envelope proteins are formed by two subunits, the transmembrane (TM) that anchors the protein into the lipid membrane and the surface (SU) which binds to the cellular receptors (Fig. 1).

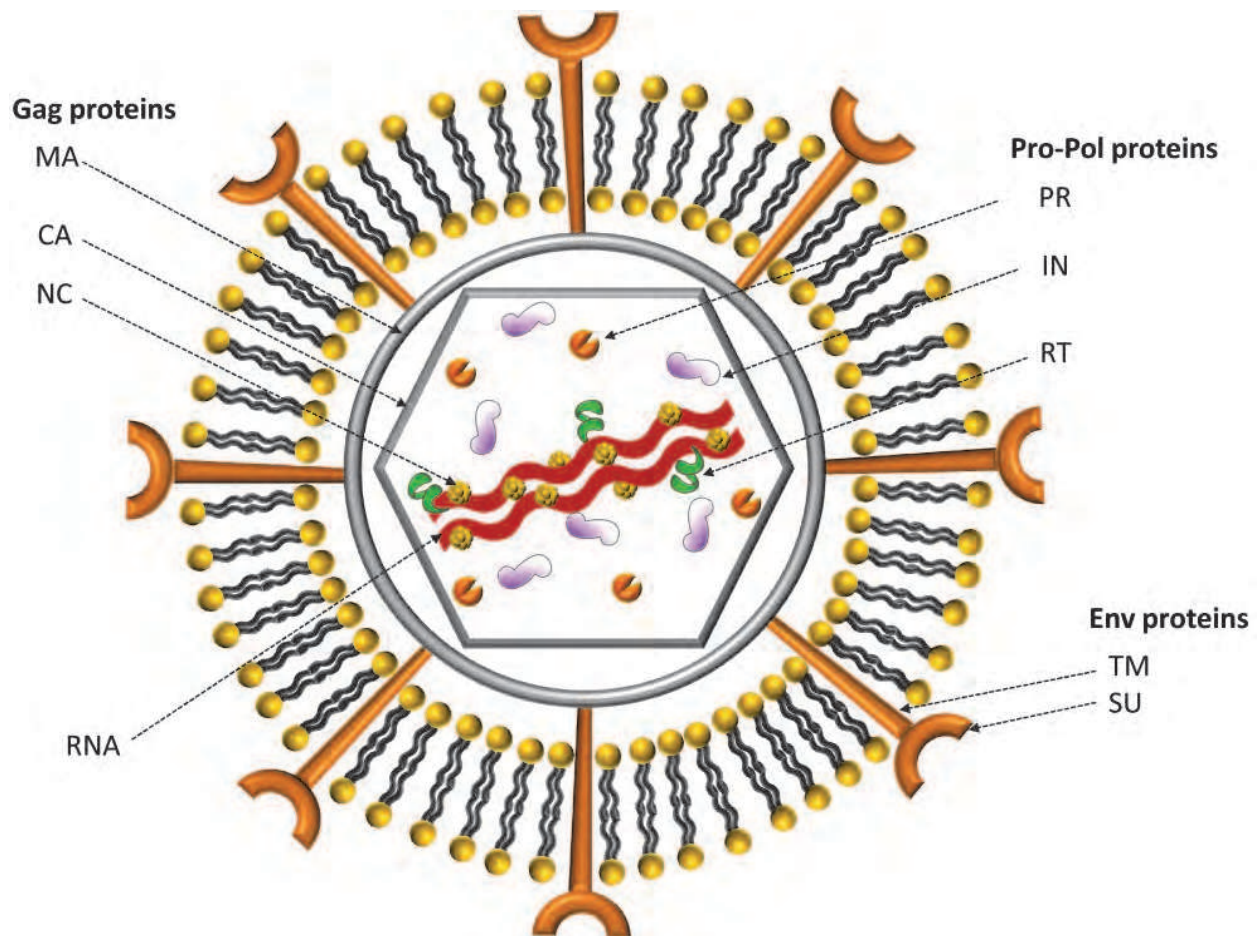

Fig. 1. Schematic representation of a retrovirus particle structure.

Based on the genome structure, retroviruses are classified into simple (e.g. MLV, murine leukemia virus) or complex retroviruses (e.g. HIV) (Coffin et al. 1997). Both encode four genes: *gag* (group specific antigen), *pro* (protease), *pol* (polymerase) and *env* (envelope) (Fig. 2). The *gag* sequence encodes the three main structural proteins: MA, CA, NC. The *pro* sequence, encodes proteases (PR) responsible for cleaving Gag and Gag-Pol during particles assembly, budding and maturation. The *pol* sequence encodes the enzymes RT and IN, the former catalyzing the reverse transcription of the viral genome from RNA to DNA during the infection process and the latter responsible for integrating the proviral DNA into the host cell genome. The *env* sequence encodes for both SU and TM subunits of the envelope glycoprotein. Additionally, retroviral genome presents non-coding *cis*-acting sequences such as, two LTRs (long terminal repeats), which contain elements required to drive gene expression, reverse transcription and integration into the host cell chromosome, a sequence named packaging signal (ψ) required for specific packaging of the viral RNA into newly forming virions, and a polypurine tract (PPT) that functions as the site for initiating the positive strand DNA synthesis during reverse transcription (Coffin et al. 1997).

Additionally to *gag*, *pro*, *pol* and *env*, complex retroviruses, such as lentiviruses, have accessory genes including *vif*, *vpr*, *vpu*, *nef*, *tat* and *rev* that regulate viral gene expression, assembly of infectious particles and modulate viral replication in infected cells (Fig 2B).

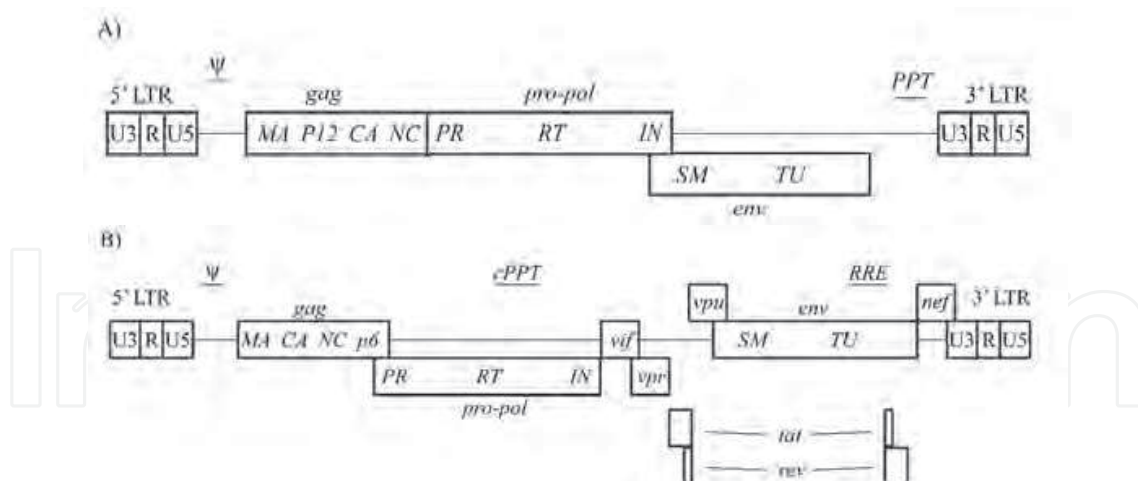

Fig. 2. Retroviral genomes. Schematic representation of (A) MLV and (B) HIV-1 wild-type genomes representing simple and complex retrovirus, respectively.

2. Cell line platforms for the production

The establishment of retroviral and lentiviral producer cells, named packaging cell lines, has been based on the physical separation of the viral genome into different transcriptional units to minimize the risk of generating replication-competent particles (RCPs) (Fig. 3). Some of

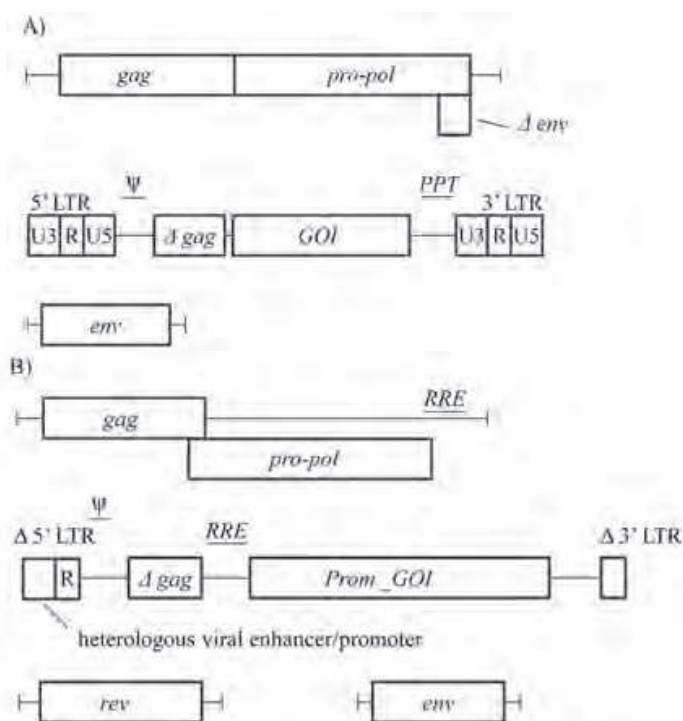

Fig. 3. Transcriptional units used for retroviral and lentiviral vector generation. (A) Three construct system used for (simple) retroviral vector and (B) four construct system used for third generation lentiviral vector production. Only the most relevant parts of the constructs are shown; for further details see (Blesch 2004; Sinn et al. 2005). GOI: gene of interest; Prom_GOI: heterologous promoter and gene of interest.

these constructs are additionally engineered with heterologous sequences including: promoters (Dull et al. 1998) to support their independent expression or for improved safety, enhancers (Gruh et al. 2008) and stabilizing elements (Zufferey et al. 1999) to increase the overall levels of transcripts both in producer and target cells, hence increasing viral titers and transgene expression.

2.1 Retroviral vectors

For both retroviral and lentiviral vector production, different packaging systems, named generations, have been developed. Each new generation aimed at minimizing and reduce the risk of RCPs formation face to the previous one (Fig 3).

In the case of vectors based on MLV or other simple retrovirus, the non-cytotoxicity of the viral genes has allowed the establishment of cell lines stably and constitutively expressing viral vectors. Table 1 lists some of the available retroviral vector packaging cell lines.

The first packaging cells reported as so for simple retroviral vector production were established by providing the packaging functions (*gag-pro-pol*) with a retroviral genome where the packaging signal was deleted, thus preventing their incorporation into the viral particles (Cone and Mulligan 1984). However, a single event of homologous recombination was sufficient to restore replicative competence. This led to a second generation of retroviral packaging cells (Miller and Buttimore 1986), in which further modifications were introduced including the replacement of the 3'LTR and the second strand initiation site with the polyadenylation site of SV40. The third generation (Danos and Mulligan 1988) (Fig. 3A) further separates the construct that expresses *gag-pro-pol* from *env*, in a total of three independent transcriptional units. Although three homologous recombination events would be needed to restore replicative competence, which is very improbable, replicative competent viruses can still occur in third generation cell lines (Chong et al. 1998; Chong and Vile 1996). Therefore, additional improvements were made by means of decreasing the homology in the vector construct, using different LTR species to those used in the packaging functions (Cosset et al. 1995) or using heterologous promoters such CMV's (Rigg et al. 1996; Soneoka et al. 1995). The most recently developed retroviral vector packaging cell lines are based on this third generation optimized system. *Gag-pro-pol* genes are expressed from a single construct driven by a heterologous promoter. Vector construct contains a cassette for transgene expression typically driven by the 5'LTR promoter; it additionally contains the packaging signal (ψ) and the initial *gag* sequence known to provide enhanced packaging (Bender et al. 1987). The envelope expression is supplied by a third independent construct usually driven by a heterologous promoter. The separation of the envelope in an independent transcriptional unit offers great flexibility for envelope exchange - pseudotyping - and for the use of genetically or chemically engineered envelope proteins, thus allowing changing, restricting or broadening vector tropism (McTaggart and Al-Rubeai 2002; Yu and Schaffer 2005). For simple retroviruses several envelope glycoproteins have been used including MLV's amphotropic 4070A and 10A1 (Miller and Chen 1996), GaLV's (gibbon leukemia virus) (Miller et al. 1991), RD114 from cat endogenous virus (Takeuchi et al. 1994), HIV's gp120 (Schnierle et al. 1997) and the G protein from vesicular stomatitis virus (VSV-G) (Burns et al. 1993). Since the proteins encoded by these sequences are usually non-toxic, except for the last one, they can be constitutively expressed such that simple retroviral vector packaging cell lines are typically stable and continuously producing systems.

Retroviral producer cell lines	Cell origin	Envelope	Maximal Titers (I.P./mL)	Vector	Packaging generation	Reference
Ψ-AM	Murine NIH 3T3	Amphotropic	2.0×10^5	MLV based	1 st	(Cone and Mulligan 1984)
PA317	Murine NIH 3T3	Amphotropic	3.0×10^6	MLV based	2 nd	(Miller and Buttimore 1986)
Ψ-CRIP	Murine NIH 3T3	Amphotropic	6.0×10^6	MLV based	3 rd	(Danos and Mulligan 1988)
PG13	Murine NIH 3T3	GaLV	5.0×10^6	MLV based		(Miller et al. 1991)
Gp + envAm12	Murine NIH 3T3	Amphotropic	1.0×10^6	MLV based		(Markowitz et al. 1988)
HAI1	Human HT1080	Amphotropic	1.0×10^7	MLV based		(Sheridan et al. 2000)
FLY A4	Human HT1080	Amphotropic	1.0×10^7	MLV based		(Cosset et al. 1995)
FLY RD18	Human HT1080	RD114	1.2×10^5	MLV based		(Cosset et al. 1995)
Te Fly A	Human Te671	Amphotropic	1.0×10^7	MLV based		(Cosset et al. 1995)
Te Fly Ga 18	Human Te671	GaLV	1.0×10^6	MLV based		(Cosset et al. 1995)
CEM FLY	Human CEM	Amphotropic	1.0×10^7	MLV based		(Pizzato et al. 2001)
293-SPA	Human 293	Amphotropic	6.0×10^6	MLV based		(Davis et al. 1997)
293 kat	Human 293	Amphotropic Xenotropic 10A1	NR	MLV based		(Farson et al. 1999)
Phoenix	Human 293T	Amphotropic	1.0×10^5	MLV based		(Swift et al. 2001)
Flp293	Human 293	Amphotropic	2.0×10^7	MLV based		3 rd with RMCE ¹ technology
293 FLEX	Human 293	GaLV	3.0×10^6	MLV based	(Coroadinha et al. 2006b)	
PG368	Murine NIH 3T3	GaLV	1.0×10^6	MLV based	(Loew et al. 2009)	

Table 1. Packaging cell lines for retroviral vector manufacture (1 – RMCE – Recombinase Mediated Cassette exchange; NR – Not reported: the titers reported for these packaging cells are expressed in terms of reverse transcriptase activity, which the correlation with infectious titers depends on the cell system.)

Retroviral vectors have been based on several viruses including avian, simian, feline and murine retroviruses, being the latter (MLV) the most used. As so, the majority of the retroviral vector packaging cell lines established were murine derived, being NIH/3T3 the most widely employed. However, it was rapidly found that the presence of galactosyl(α 1-3)galactose carbohydrate moieties produced by murine cells in retroviral envelope lead to its rapid detection and inactivation by the human complement system (Takeuchi et al. 1994; Takeuchi et al. 1997; Takeuchi et al. 1996). Nowadays, murine cells are being replaced by human cell lines, to reduce the possibility of endogenous retroviral sequences packaging and also to improve vector half-life *in vivo* (Cosset et al. 1995). Establishing a producer cell line involves at least three transfection and clonal selection steps, taking a time-frame of around one year which constitutes a major drawback in stable cell line development (see section 3.1). Yet, this process is undertaken for each new therapeutic gene and/or different envelope protein required (for changing vector tropism). On the other hand, high-titer packaging cells development has been based on an efficient method to facilitate the selection of a high producer cell clone in which a selectable marker gene is inserted in the vector construct downstream of the viral genes, so they are translated from the same transcript after ribosomal reinitiation (Cosset et al. 1995). This strategy, however, although very efficient for screening stable integration and/or high level long-term viral genome expression, raises considerable problems in therapeutic settings including immune response against the selection (foreign) gene product(s) (Liberatore et al. 1999). Therefore, a new generation of retrovirus packaging cell lines based on cassette exchange systems that allow for flexible switch of the transgene and/or envelope, as well as selectable marker(s) excision, were developed (Coroadinha et al. 2006b; Loew et al. 2004; Persons et al. 1998; Schucht et al. 2006; Wildner et al. 1998). Schucht et al (2006) and Coroadinha et al (2006) established modular cell lines, based on targeted genome integration allowing to obtain rapidly high-titer retroviral producer cells (Figure 4).

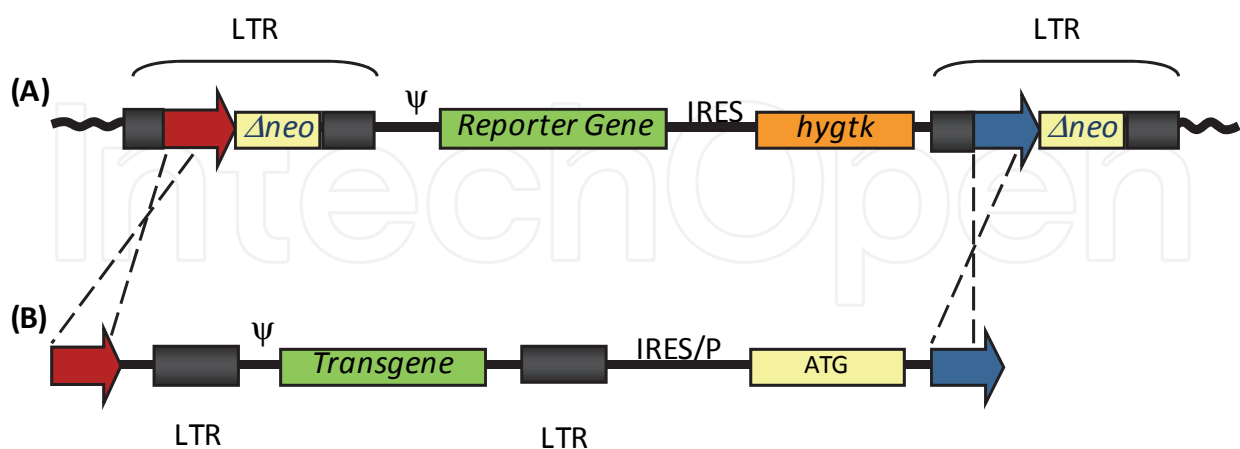

Fig. 4. Schematic representation of the modular cell lines based on the recombinase mediated cassette exchange (RMCE) technology. (A) Integrated retroviral transgene cassette harboring a marker gene and (B) targeting therapeutic transgene plasmid allowing a fast exchange and establishment of a new retroviral producer cell.

Two cell lines were created; Flp293A and 293 FLEX, both derived from 293 cells. The former pseudotyped with amphotropic and the latter with GaLV envelopes. Recently, a PG13-based murine producer cell line was also established using this strategy (Loew et al. 2009). A favorable chromosomal site for stable and high retroviral vector production is first identified and tagged. Due to the presence of two heterologous non-compatible FRT sites flanking the tagged retroviral genome, the subsequent re-use of this defined chromosomal site by means of RMCE is then performed to express a therapeutic gene. In order to select cell clones that underwent correct targeted integration reaction, the targeting viral vector contains a start codon that complements a transcriptionally inactive ATG-deficient selection marker after recombination.

The modular producer cell lines present several advantages: they are safer since integration of the vector within the packaging cell line was identified, the duration of the entire development process is much reduced as there is no need for screening and, in addition, production conditions are favorable due to the possibility of pre-adaptation of the master cell line to culture conditions and media. Thus, therapeutic virus production from bench to bedside becomes safer, faster, and cheaper (Coroadinha et al. 2010).

2.2 Lentiviral vectors

Similarly to retroviral vectors, the design of lentiviral vector packaging systems has evolved to minimize the risk of RCPs generation towards maximum safety. Currently, three generations of lentiviral vectors are considered. The first-generation (Naldini et al. 1996) closely resembles the three plasmid packaging system of simple retroviruses, except for the fact that the *gag-pol* expression is driven by a heterologous promoter instead of the viral LTR; additionally, the gp120 HIV-1's envelope was replaced by VSV-G's. However, this system contained all the necessary sequences for the generation of RCPs with three homologous recombination events which, although improbable, could not be accepted for a human and potentially lethal pathogen.

In the second generation (Zufferey et al. 1997), the three plasmid system was maintained but all the accessory genes were deleted including *vif*, *vpr*, *vpu*, and *nef*. The third generation (Fig. 3B) allowed for a *tat* independent lentiviral vector expression by engineering a chimeric 5'LTR with a heterologous viral promoter/enhancer, such as CMV's (cytomegalovirus) or RSV's (Rous sarcoma virus) (Dull et al. 1998); *rev* complementation was separately provided in *trans*, thus this system has a total of four constructs. A schematic representation of the third generation system is shown in Fig. 3B. *Gag-pro-pol* genes are expressed from a CMV promoter and none of the accessory or regulatory proteins is present in this construct. Only *rev* accessory gene is maintained but is provided by a nonoverlapping plasmid. Vector cassette for transgene expression is driven by a heterologous promoter, as virus LTRs were partially deleted. Similarly to simple retroviruses, the transgene vector construct additionally contains the packaging signal (ψ) and the initial sequence from *gag*. The envelope cassette encodes typically, but not necessarily, for VSV-G envelope glycoprotein.

The development of a fourth generation of lentiviral vectors, *rev* independent, has also been claimed by means of replacing RRE (*rev* responsive element) with heterologous viral sequences or by codon-optimization (Bray et al. 1994; Delenda 2004; Kotsopoulou et al. 2000; Pandya et al. 2001; Roberts and Boris-Lawrie 2000). However, its use is not widespread

since, contrary to the other generations of lentiviral vectors, these packaging systems have not been made available for the research community; also the reported titers are typically one to two logs below the maximum titers obtained with the second or third generation systems.

In addition to HIV-derived, other lentiviral vectors have been developed and reported to retain identical features to those of HIV's based, including the ability to transduce non-dividing cells, high titers production, and the possibility to be pseudotyped with different envelope glycoproteins. These include lentiviral vectors based on SIV (simian immunodeficiency virus) (Pandya et al. 2001; Schnell et al. 2000), BIV (bovine immunodeficiency virus) (Matukonis et al. 2002; Molina et al. 2004), FIV (feline immunodeficiency virus) (Poeschla et al. 1998; Saenz and Poeschla 2004) and EAIV (equine infectious anaemia virus) (Balaggan et al. 2006; Mitrophanous et al. 1999; Stewart et al. 2009). Most of non-HIV derived lentiviral vectors have been reported to be *tat* and sometimes *rev* independent, thus falling in the 3rd or 4th generation of packaging systems. For clinical trials purposes, both second and third generation lentiviral vector systems were reported although only HIV-1 and EAIV derived vectors have been used (Schweizer and Merten 2010).

Contrarily to simple retroviral vectors, the cytotoxicity of some of the lentiviral proteins has hampered the establishment of stable cell lines constitutively expressing vector components. Therefore, the majority of the reported packaging cells for lentivirus manufacturing have been based on inducible systems that control the expression of the toxic proteins (for further details see section 3.1). Nevertheless, it is worth notice that transient production is still the main mean for lentiviral vector generation for both research and clinical purposes. Table 2 summarizes some of the available (stable) lentiviral vector packaging cell lines.

Except for the systems reported by and Ni et al. (2005), all the packaging cell lines for lentiviral vector production have been based on human 293 cells transformed with oncogenes such as the SV40 (simian vacuolating virus 40) large T antigen - 293T - or the Nuclear Antigen of Epstein-Barr Virus - 293EBNA.

For clinical application human 293 and 293T cells have been the exclusive cell substrates (Schweizer and Merten 2010). However, safety concerns arise from the fact that 90% of non-coding mobile sequences of the human genome are endogenous retrovirus and although most of them are defective, because of mutations accumulation, some are still active (Zwolinska 2006). Therefore, using human cell lines for the production of human retroviruses increases the chances of replicative-competent particles generation by homologous recombination (Pauwels et al. 2009). Also, the possibility of contamination with other human pathogens during the production process, poses additional hindrances to the use of human cells for biopharmaceuticals production, viral or not. In this context, the use of non-human cells would be strongly recommended, although the different glycosylation patterns of the envelope proteins could be an obstacle. For research purposes other human or monkey derived cells were tested (other 293 derived clones, HeLa, HT1080, TE671, COS-1, COS-7, CV-1), although most of them showed reduced vector production titers. Yet, COS-1 cells have shown to be capable of producing 3-4 times improved vector quality (expressed in infectious vector titer *per* ng of CA protein, p24), comparing with 293T cells (Smith and Shioda 2009).

Lentiviral packaging cell line	Cell origin	Envelope	Maximal Titers (I.P./mL)	Vector	Packaging generation ¹	Observations	Reference
SODk	Human 293T	VSV-G	1.0×10^7	HIV-1 based	2 nd	Tet-off	(Cockrell et al. 2006; Kafri et al. 1999; Xu et al. 2001)
293G	Human 293T	VSV-G	-	HIV-1 based	2 nd	Tet-off	(Farson et al. 2001)
STAR	Human 293T	Ampho GaLV RD114	1.2×10^7 1.6×10^6 8.5×10^6	HIV-1 based	2 nd	Continuous system. Codon-optimized <i>gag-pol</i>	(Ikeda et al. 2003)
NR	Human 293	VSV-G	3.5×10^7	HIV-1 based	2 nd	Tet-off. Three level cascade gene regulation system: TRE → tat+rev → VSV-G+Gag-Pol. Codon-optimized <i>gag-pol</i>	(Ni et al. 2005)
REr1.35	Human 293T	VSV-G	1.8×10^5	HIV-1 based	3 rd	Ecdysone inducible system. Codon-optimized <i>gag-pol</i>	(Pacchia et al. 2001)
293SF-pacLV	Human 293 EBNA	VSV-G	3.4×10^7	HIV-1 based	3 rd	Tet-on	(Broussau et al. 2008)
PC48	Human 293T	VSV-G	7.4×10^5	EIAV based	3 rd	Tet-on	(Stewart et al. 2009)
SgpG109	Human 293T	VSV-G	1×10^5	SIV-based	3 rd	Ponasterone inducible system. Codon-optimized <i>gag-pol</i>	(Kuate et al. 2002)
GPRG	Human 293T	VSV-G	5×10^7	SIV-based	3 rd	Introduction of vector by concatemeric array transfection. Tet-off	(Throm et al. 2009)

Table 2. Packaging cell lines for lentiviral vector manufacture (1 - No lentiviral packaging cell line was developed based on the first generation lentiviral vector system.

Tet-on/ Tet-off - tetracycline inducible system; tet-on becomes active upon tetracycline (or an analogous molecule such as doxycycline) is added and tet-off is activated by tetracycline removal. NR: not reported)

3. Bioreaction platforms and production media

3.1 Stable vs. transient expression

Production platforms for lentiviral and retroviral vectors have been restrained to mammalian cells, typically murine or human derived, which are transfected with *gag-pol* the packaging functions, vector (transgene) and envelope constructions. This can be based on a short-term transfer of the viral constructs, known as transient production, into exponentially growing cells followed by 24-72 hours vector production and harvesting, or by their stable

integration and constitutive expression into the host cell genome, for continuous production (Fig. 5).

Transient production, makes use of transfection methods to introduce the viral constructions, commonly cationic agents that complex with the negatively charged DNA, thus allowing it to be up-taken by the cell *via* endocytosis (Al-Dosari and Gao 2009). From those, polyethylenimine (PEI) (Boussif et al. 1995) is probably the less expensive, one of the most efficient and the most widely used in the current protocols (Schweizer and Merten 2010; Segura et al. 2010; Toledo et al. 2009). Others methods such as calcium phosphate precipitation (Jordan and Wurm 2004; Mitta et al. 2005) and cationic lipids complexation including LipofectAMINE® and FuGENE®, have also been used, although at small-scale production or for research purposes only since, these are either difficult to scale-up or very expensive. Alternatively, viral infection has also been developed and validated namely for lentiviral vector production, using baculoviruses as transfection agents (Lesch et al. 2008). However, the additional downstream work to separate lentiviral vector and baculoviruses to achieve clinical-grade viral preparations standards, as well as the final titers reported (Lesch et al. 2011) reduced the competitiveness of lentiviral vector production using baculoviruses over plasmid DNA transfection methods.

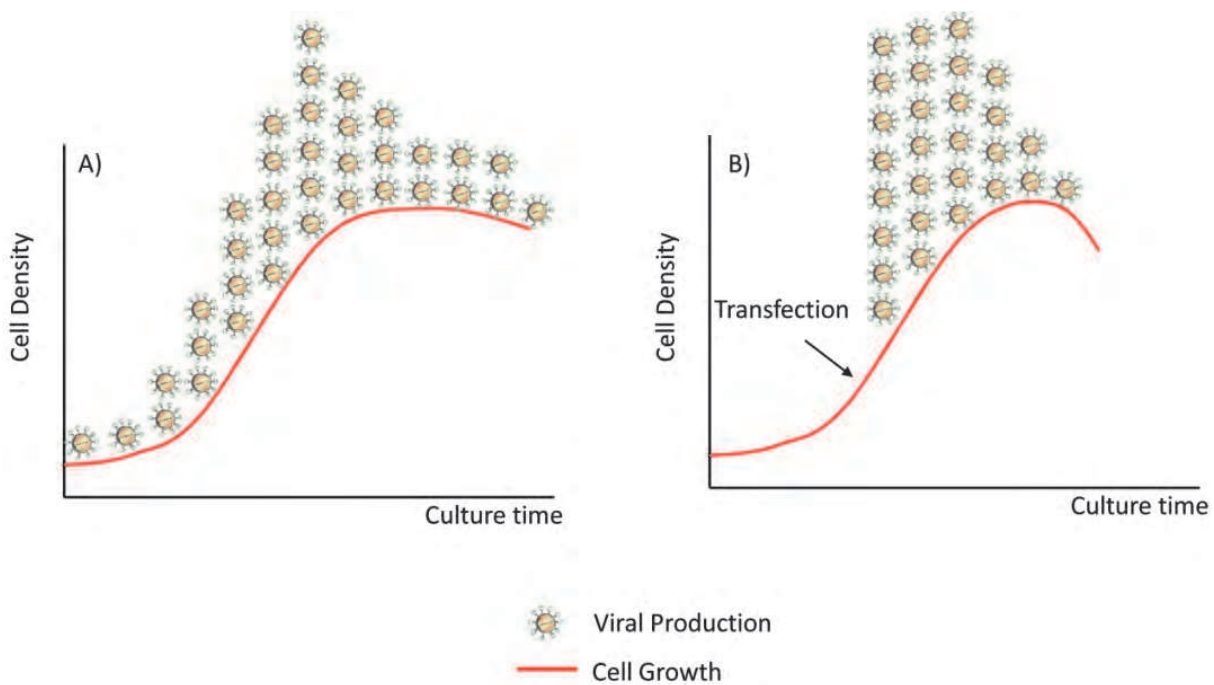

Fig. 5. Stable *vs.* transient viral vector production. (A) Stable and continuous production from cell lines constitutively expressing viral vector transgene, *gag-pro-pol* and *env*; vector titers are nearly dependent on cell density until the end of the exponential phase of cell growth. (B) Transient production after plasmid transfection of viral vector transgene, *gag-pro-pol* and *env*; high titers are obtained usually between 24 to 72 hours post-transfection, after which a pronounced decrease occurs, typically due to cell death.

Stable production relies on cell substrates in which the viral constructs were separately integrated into the cell genome, thus allowing their constitutive expression. Typically, the packaging functions are first inserted and after clonal selection of a high-level *gag-pol* expression, the envelope construction is then inserted and a second round of clonal selection

is performed. At this point, a packaging cell line is established, in principal supporting the packaging of any viral vector (retroviral or lentiviral, depending on the *gag-pro-pol* functions). Finally, the transgene is introduced. If non-SIN vectors are used, this can be achieved directly by viral infection; otherwise, chemical transfection methods as those described above followed by stable integration and selection are required and equally suitable. Cosset and co-workers (1995) reported a very efficient method in which viral vector construct containing a (selectable) marker gene is firstly inserted in nude cells, facilitating the screening for stable integration and high-level long term expression (Cosset et al. 1995). This scheme was demonstrated to allow for the establishment of high-titer human derived retroviral vector packaging cell lines. Additionally, it permits high-titer retroviral vector production from single copy integration allowing for modular cell lines development, flexible platforms for transgene and/or envelope exchange (Coroadinha et al. 2006b; Schucht et al. 2006) (Fig. 4). Moreover, it allows optimization of the stoichiometry of the packaging constructs, maximizing viral titers and vector preparation quality, expressed by the ratio of infectious particles to total particles, which has a drastic impact on vector transduction efficiency a crucial parameter for clinical purposes (Carrondo et al. 2008).

Stable retroviral vector cell line development is a tedious and time consuming process which can take up to one year for a fully developed and characterized cell platform. However, it is compensated by obtaining continuously producing and highly consistent cell systems, prone to single-effort bioprocess and product characterization, a critical consideration for market approval.

Transient production is undoubtedly faster, when compared to the time frame necessary to develop a stable packaging cell line, presenting very competitive titers (up to 10^7 infectious vector *per* mL). Yet, for clinical purposes, continuous production by stable cell lines is highly desirable, since transient systems are difficult to scale-up, time and cost-ineffective at large scales and, more importantly, are unable to provide a fully characterized production platform with low batch-to-batch variability of the viral preparations. Therefore, transient production is unlikely to be of value after the transition from clinical to market. Retroviral vector manufacture, including those used in clinical trials, has been making use of stable and continuous cell lines for more than ten years (Cornetta et al. 2005; Eckert et al. 2000; Przybylowski et al. 2006; Wikstrom et al. 2004). However, the establishment of stable lentiviral vectors packaging cell lines has remained a challenge due to the inherent cytotoxicity of the lentiviral protease which has prohibited its constitutive expression (Schweizer and Merten 2010). It is well established that numerous HIV-1-encoded proteins are capable of causing cell death, including *tat*, *nef*, *env*, *vpr* and the protease (PR) (Gougeon 2003); from those, only the protease is still required in the current packaging systems. HIV protease mediates its toxicity *in vitro* and *in vivo*, by cleaving and activating procaspase 8, leading to mitochondrial release of cytochrome c, activation of the downstream caspases 9 and 3 and lastly, nuclear fragmentation (Nie et al. 2007; Nie et al. 2002). Ikeda and co-workers have reported the development of a 293T derived cell line, STAR, stable and continuously producing LV using an HIV-1 codon optimized *gag-pol* (Ikeda et al. 2003). However, significant titers could only be obtained by MLV-based vector transduction of the optimized *gag-pol*. This procedure raises biosafety issues, since it increases the chances of generating replicative-competent particles by homologous recombination and, posing further concerns of co-packaging (Pauwels et al. 2009).

At a laboratory scale, transient production by plasmid transfection has been the first choice to cope with the cytotoxic proteins. For larger-scale production purposes, conditional

packaging systems have been developed in which the expression of those is under the control of inducible promoters (Broussau et al. 2008; Farson et al. 2001; Kuate et al. 2002; Pacchia et al. 2001; Stewart et al. 2009). However transient transfection systems are, as discussed above, difficult to scale-up and do not fulfill adequate batch-to-batch variability standards; and, although the clinical trials currently using lentiviral vectors have been provided exclusively with transiently produced batches (Schweizer and Merten 2010), it is unlikely that a transient based systems will be approved when going from clinical to market. Conditional systems, on the other hand, require the addition/removal of the induction agents cumbering the production and requiring further down-stream stringency in processing of the viral preparations.

3.2 Stirred bioreaction vs. adherent cultures

It is widely accepted that stirred bioreaction systems using suspension cultures offer more advantages from the bioprocess view-point when compared to those under static/adherent conditions. The most evident advantage is the higher volumetric productivity, since suspension cultures in stirred systems present increased ratios of cell number *per* volume of culture medium. Because of this, they are easier to scale-up with less space requirements; the agitation allows for homogeneous cells suspension preventing the formation of chemical (nutrient, waste products), physical (pH, oxygen, carbon dioxide) and thermal gradients, thus maximizing the productivity potential of the culture (Sadettin and Hu 2006).

The first suspension system reported for high-titer retroviral vector production was based on a T-lymphoblastoid cell line using a third generation packaging construct, producing MLV derived retroviral vectors pseudotyped with amphotropic envelope: CEMFLYA cells (Pizzato et al. 2001). These cells were able to produce in the range of 10^7 infectious units *per* mL and, the potential for scaled up vector production was demonstrated by continuous culture during 14 days in a 250 mL spinner flask. After CEMFLYA, other high-titer suspension cells were reported, namely suspension-adapted 293GPG cells producing MLV retrovirus vector pseudotyped with the vesicular stomatitis virus G (VSVG) envelope protein and expressing a TK-GFP fusion protein in a 3L acoustic filter-based perfusion bioreactor (Ghani et al. 2006). Another major landmark was achieved when the same group published for the first time retroviral vector production in suspension and under serum-free conditions (Ghani et al. 2007) (see section 3.4.1). Following retrovirus, lentiviral vector manufacture using suspension cultures has also been recently reported both for transfection-based transient production (Ansoerge et al. 2009), as well as, for stable production using (inducible) packaging cell lines (Broussau et al. 2008).

Despite the advances in the development of suspension cultures for stirred tank bioreactors and its clear advantage from the bioprocess view-point, retroviral and lentiviral vector manufacture for clinical batches has mainly been based on adherent static and preferably disposable systems, including large T-flasks, cell factories and roller bottles (Fig. 6) (Eckert et al. 2000; Merten et al. 2011; Przybylowski et al. 2006; Wikstrom et al. 2004). A good example is retroviral vector production at the National Gene Vector Laboratory, Indiana University, (Indianapolis, IN), a US National Institutes of Health initiative that has as main mission provide clinical grade vectors for gene therapy trials (Cornetta et al. 2005). Also for clinical-grade lentiviral vector production, the bioreaction system of choice has been Cell Factory or equivalent multitrays systems (Merten et al. 2011; Schweizer and Merten 2010). These systems allow for 10 to 40 L vector production under GMP conditions, meeting the needs for initial trials, where usually a reduced number of patients are involved. In the

future, if lentiviral and retroviral vector Gene Therapy products reach the market, it is still not clear if such systems will continue to be used. In fact, several restrictions arise from the use of disposable systems and bioreactors including the increase in the costs of solid waste disposal and consumables, in addition to low scalability and the single-use philosophy itself (Eibl et al. 2010). However, the low infectivity stability of retro and lentiviral vectors has hampered the perspective of the “thousand-liter” production systems’ for further storage. Nevertheless, significant efforts are being made to overcome this drawback including, at the bioprocess level, by developing storage formulations (Carmo et al. 2009a; Cruz et al. 2006) and at the viral vector design level, by developing mutant vectors with increased infectivity stability (Vu et al. 2008).

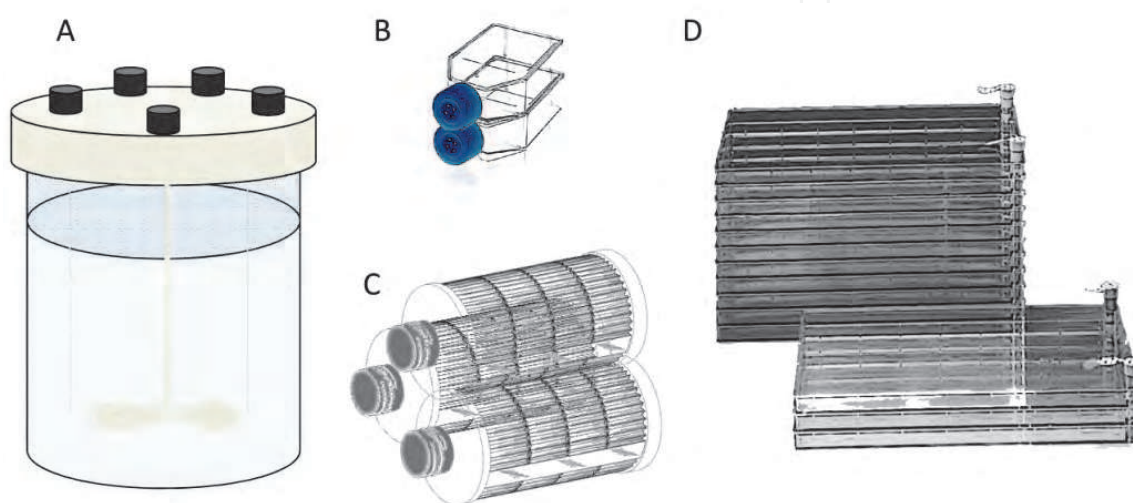

Fig. 6. Culture systems used for retroviral and lentiviral vector manufacture. Stirred tank bioreactor (A) vs. adherent disposable systems, T-flasks (B), roller bottles (C) and (D) cell factories.

3.3 Bioreaction physicochemical parameters

The cell culture parameters used in the bioreaction may have a profound effect on the virus titer by affecting the cellular productivities, vector stability or both. Several studies have been performed analyzing the impact of physicochemical parameters such as pH, temperature, osmolarity, O₂ and CO₂ concentrations. The optimal cell culture parameters have been shown to be producer cell line and viral vector dependent.

The optimal pH range for retroviral vector production was found to be between 6.8 and 7.2 for FLY RD18 and Te FLY A7; outside this range the cell specific productivities were considerable lower (McTaggart and Al-Rubeai 2000; Merten 2004), while the retroviral vector was observed to be stable between pH of 5.5 and 8.0 in ecotropic pseudotyped vectors (Ye et al. 2003). Both retroviral vectors (MLV derived) and lentiviral vectors (HIV-1 derived), VSV-G pseudotyped, were stable at pH 7. The half-lives of both viral vectors at pH 6.0 and pH 8.0 markedly decrease to less than 10 minutes (Higashikawa and Chang 2001). The viral half-life is also dependent on the temperature: at lower temperatures the vector decay kinetics are lower (Le Doux et al. 1999). Therefore one strategy explored in the production of retroviral vectors has been the reduction of the culture temperatures (28-32°C). Some authors reported increases in vector production at lower temperature (Kaptein et al. 1997; Kotani et al. 1994; Le Doux et al. 1999; Lee et al. 1996). The reduction of the

culture temperature from 37°C to 32°C extends vector stability allowing for the accumulation of more infectious virus and thus, increasing the volumetric titers. However, the increments are not always very significant as the temperature affects also the cell specific yields negatively. The improvement in the viral volumetric titer will be only observed if, the increase in the viral half-life is higher than the decrease in the cell specific production rate (Le Doux et al. 1999). Additionally, the viral vector inherent stability was also demonstrated to be lower when the viral vector was produced at 32°C instead of 37°C (Beer et al. 2003; Cruz et al. 2005). It was shown that the culture temperature affected the lipid viral membrane composition namely, the cholesterol content. The increase in cholesterol content was demonstrated to be inversely proportional to retroviral stability (Beer et al. 2003; Coroadinha et al. 2006c). Since enveloped virus, such as retrovirus and lentivirus, bud out of the host cells, they take part of the host cell lipidic membrane. Thus, the origin of the producer cell will have a pronounced effect on the viral particle stability and explain the discrepant results obtained for virus produced in different cells and at different temperatures. For PA317 cells, decreasing the production temperature from 37°C to 32°C resulted in an increase of 5-15 fold in the vector titers (Kaptein et al. 1997) while for PG13 lower titers were obtained (Reeves et al. 2000). The viral vector envelope glycoproteins also affect the viral particle inherent stability increasing the complexity and diversity of factors involved in the viral stability. Comparing lentiviral and retroviral vectors it was generally observed that HIV-1 derived vectors are more stable at 37°C and at higher temperatures than MLV derived vectors (Higashikawa and Chang 2001).

Augmenting the media osmolarity was also shown to be a valid strategy to increase retroviral vector titers in Te FLY A7 (Coroadinha et al. 2006c). This increment was correlated with higher cell specific productivities and higher inherent viral stability. The high osmotic pressure altered the cellular and viral envelope lipid membrane composition. High osmotic media were tested showing to induce a decrease in the cholesterol to phospholipids ratio in the viral membrane and thus conferring higher stability to the viral vectors produced (Coroadinha et al. 2006c). These results, together with the studies of production at lower culture temperatures, strengthen the importance of lipid metabolism in the production of enveloped virus.

CO₂ gas concentration in the cultures did not affect virus production in packaging cell lines (Kotani et al. 1994; McTaggart and Al-Rubeai 2000). The dissolved oxygen levels used are between 20-80% and within this range do not affect viral production unless they became limiting to cell growth (Merten 2004).

3.4 Media composition and cell metabolic bottlenecks

Retroviral and lentiviral vector titers obtained in the production prior to purification are in the range of 10⁶ to 10⁷ infectious particles *per* mL of culture medium. Considering the average amount needed to treat a patient in a clinical trial, in the order of 10¹⁰ infectious vectors (Aiuti et al. 2009; Cavazzana-Calvo et al. 2000; Ott et al. 2006), around 10-100 L of culture volume can be previewed for each patient. Also, viral preparations are typically characterized by low ratios of infectious particles to total particles (around 1:100) which further reduce the therapeutic efficiency of the infectious ones (Carrondo et al. 2008). Additionally, these vectors are extremely sensitive losing their infectivity relatively fast, the reported half-lives are between 8-12 hours in cell culture supernatant at 37°C (Carmo et al. 2009b; Carmo et al. 2008; Higashikawa and Chang 2001; Merten 2004; Rodrigues et al. 2009). Thus, the productivity performance of retroviral and lentiviral vector producing systems is below the therapeutic needs.

The problems of low titers, short half-life and low ratios of infectious particles to total particles have been subject of intensive bioprocess research. However, the infection with wild type retroviruses, in particular HIV-1, is typically chronically and characterized by persistent but low titers of the infectious agents in the blood stream, with high amounts of non-infectious particles contaminants and with equivalently low half-lives (Perelson et al. 1996; Rusert et al. 2004). Therefore, retrovirus and lentiviral manufacture starts in disadvantage - when compared to other viral vectors - in what concerns to such parameters. Several strategies have been attempted to circumvent these "natural" drawbacks in packaging cell lines, including engineering mutant vectors with improved resistance features and understanding and optimizing the metabolic pathways leading to improved productivities. Studying the metabolic features driving to high titer performances has been one important work lines of research. Therefore, this section will mainly focus on the metabolic bottlenecks of viral vector production.

3.4.1 Serum supplemented vs. serum-free media

The supplementation of mammalian cell culture media with animal sera has been common practice in biomedical and biotechnological research, since it provides critical nutrients and factors that support cell growth and proliferation. However, the ill-defined composition and high batch-to-batch variability of serum together with its potential source of contaminations, hinders safety and standardization of cell cultures, making it a highly undesirable supplement in the production of biopharmaceuticals (Falkner et al. 2006). Also, in the case of retroviral and lentiviral vectors, serum needs to be removed from the medium and/or viral preparations to prevent immunological responses in the patients.

Retroviral and lentiviral vector manufacture has been reported to rely on considerable amounts (5-10% (v/v)) of animal sera in the culture medium; although some authors reported improved titers in short-term serum-free productions (Gerin et al. 1999a; McTaggart and Al-Rubeai 2000), the issue of serum dependence for retroviral and lentiviral vector production will be next discussed in the perspective of long-term cultures. The majority of the latest generation of packaging cell lines, specially the HEK293 (human embryonic kidney) derived ones, seem to require high concentrations of serum in the culture medium to support elevated viral productivities for long term culture (Chan et al. 2001; Gerin et al. 1999a; Gerin et al. 1999b; Pizzato et al. 2001; Rodrigues et al. 2009).

The need of serum for retroviral and lentiviral vector production has been mainly associated with the lipidic needs of packaging cell lines. Unless other supplements are added, serum is the only lipid source of the culture medium and, although cells should be able to sense lipid absence in the culture medium and activate biosynthetic pathways to stand up to lipid deprivation, the activation of lipid *de novo* synthesis may take hours or days, depending on the cell type (Alberts et al. 1974; Spector et al. 1980). In some cases, cells can no longer synthesize certain lipids (Seth et al. 2005). Membrane lipids are active players in the complex process of retroviral assembling, and pseudotyping that takes place at the host cell membrane, in which interactions of membrane lipid rafts select both envelope and core proteins, recruiting later the other viral components by cooperative interaction. The production of infectious particles is known to rely on the efficiency of this process, which is dependent upon a delicate equilibrium of lipid type and amounts, easily disturbed by lipid deprivation (Briggs et al. 2003). Therefore, changes in serum concentration that disturb cell membrane lipid composition will ultimately affect viral particle membrane properties (Rawat et al. 2003) possibly resulting in a higher production of non-infectious particles. In

fact, it has been not only demonstrated that lipids are one of the main serum components correlated with high retroviral infectious vector titers but also, that the reduction of serum in the culture medium affects infectious titers only, i.e. the total number of particles produced remained unaltered (Rodrigues et al. 2009). Indeed, high-titer production of retroviral and lentiviral vectors under serum-free conditions has only been achieved in the presence of lipid supplements, lipid carriers and lipoproteins addition (Broussau et al. 2008; Ghani et al. 2007).

The work done so far, addressing the issue of serum supplementation and infectious vector production, has mainly been focused on retroviral vectors, less attention has been paid to serum/lipid requirements in lentiviral vector production. Of notice is the work developed by B. Mitta et al (2005) in which optimal lentiviral production parameters were established, resulting in up to 132-fold improved productivities, and quality. The later is defined as the viral infectious titer (reflecting the number of transduction-competent lentiviral particles) relative to the number of total physical lentiviral particles produced (analysed by the levels of p24). A reduced-serum formulation was used and supplemented. Among others, lipid supplementation, included cholesterol, lecithin and chemically defined lipid concentrates. The lipid supplements were identified as the main responsables for the improved viral productivities obtained.

In the case of lentiviral vectors, the short-term production periods associated with either the transient or conditional productions have not elucidated the extent of serum dependence in the production of high-infectious vector titers. Yet, the large majority of the current protocols for the production of lentiviral vectors still make use of 5 to 10% (v/v) of serum in the culture medium and up to now, only two publications have reported the production of lentiviral vectors under serum-free conditions (Ansorge et al. 2009; Broussau et al. 2008), both of them requiring lipid supplementation.

More recently, studies on the effects of adapting retroviral vector packaging cell lines to serum deprivation conditions and how it impacts infectious vector production have been performed. These studies identified differences in cell lipid metabolism as a requirement needed by the packaging cells to be able to adapt to serum deprivation: cells capable of activating *de novo* lipid biosynthesis under serum withdrawal, particularly cholesterol, are able to be adapted to serum deprivation without significant loss of infectious vector titer production. On the other hand, cells facing serum removal from the culture medium that are unable to activate lipid biosynthesis – HEK293 – lose infectious titer productivity after a few passages (Rodrigues et al., 2011). In this context, it should be noticed that long term serum-free production of retro and lentiviral vectors reported so far has been based not only in lipid supplemented media but also on oncogene transformed 293 cells, namely 293T, transformed with SV40 large T antigen (T-Ag) and 293 EBNA, transformed with Nuclear Antigen of Epstein-Barr Virus. These cells exhibit very different physiological features when compared to their non-transformed counterparts, 293, potentially facilitating serum-independence for vector production. For instance, SV40 transformed cells were shown to require minimal serum amounts or no serum at all, in the culture medium in order to proliferate. T-Ag expression is known to allow to overcome growth arrest mediated by contact inhibition and provide to the transformed cells an anchorage independent phenotype (Ahuja et al. 2005). Additionally, T-Ag expression drives even quiescent cells to the S-Phase (Ahuja et al. 2005), potentially providing raw material for viral replication. Besides those changes mentioned above, not much is known about the long-term physiological modifications induced by T-Ag and EBNA transformation. However, it is

possible that some of those changes target lipid biosynthetic pathways, given that oncogenic neoplastic transformation is typically characterized by an increase in lipid biosynthesis and turnover (Barger and Plas 2010; Swinnen et al. 2006). In conclusion, the major metabolic hinge between serum and high titers has been demonstrated to be the lipids and cellular lipid metabolism.

3.4.2 Sugar carbon source

Glucose has been the traditional sugar source employed in animal cell culture media and thus, the most used in the production of retroviral and lentiviral vectors. Together with glutamine, glucose is the major energy and carbon source in the culture medium. It is also the universal carbohydrate in animal cell culture, since glucose cellular transporters are present in the majority of the mammalian cell types. However, glucose is rapidly consumed and inefficiently metabolized to lactate which, *per se*, is toxic to the cell. Concentrations of lactate above 5 mM can inhibit cell growth of Te Fly Ga18 cells and retroviral production (Merten et al. 2001).

The use of alternative sugar sources to glucose is a possible strategy to decrease lactate production. Indeed, the use of fructose and galactose was shown to improve the retroviral production in Te FLY A7, Te FLY Ga18, PG13 and Tel CeB cell lines (Coroadinha et al. 2006a; Merten 2004). The lactate production decreased 2 to 6 fold in galactose and fructose media and the vector titers increased up to 8 fold. Both galactose and fructose consumption rates were lower than glucose in Te Fly A7, possible due to lower specificity of the sugar transporters expressed in these cells. The best results in terms of vector titers were obtained at high concentrations of fructose (15-25 g/L) (Coroadinha et al., 2006, Merten, 2004). Additionally to the metabolic shift induced by an alternative carbon source, an effect of high osmotic pressure can also be of relevance in the improvement of viral titers (see section 3.3). The increment of infectious titers observed at high sugar concentrations in Te Fly A7 was confirmed to be the result of higher cell specific productivities, higher vector stability and lower production of defective non-infective particles (Coroadinha et al., 2006a and 2006b) (Table 3).

Medium	Osmolality (mOsm/kg)	Cell Productivity (I.P. cells ⁻¹ .h ⁻¹)	Virus Half-Life (h)	Cholesterol/Phospholipid molar ratio in viral particles
Glucose 25 mM	335	0.18 ± 0.01	8 ± 0.7	0.53±0.03
Glucose 25 mM + sorbitol	450	0.80± 0.09	14± 1	0.33±0.01
Fructose 140 mM	450	1.0± 0.1	14±2	0.30±0.01

Table 3. Effect of alternative sugar sources and media osmolality in retroviral vector production. Te Fly A7 producer cells were used in this study. Sorbitol is a non-ionic osmotic agent, non-metabolized by the cells.

Further metabolic studies were performed using ¹³C-NMR spectroscopy indicating changes in the lipid metabolism, namely higher synthesis of phospholipids (Coroadinha et al., 2006 and Amaral et al., 2008). These results show that packaging cell line metabolism deeply influences the productivity performances, in particular lipid biosynthesis, thus suggesting it to be an important target for further improve retroviral and possibly lentiviral vector titers.

No studies with alternative sugar sources have been reported with lentiviral vectors. Nevertheless, the above studies were performed with, Te671 and NIH 3T3 cells and most lentiviral vectors are produced in 293 derived cells.

4. Conclusions and outlook

Murine leukemia virus (MLV) derived vectors were the first viral vectors used in clinical trials and remain among the preferentially used vehicles for gene therapy applications due to their advantages relatively to other vectors. Lentiviral vectors have been developed more recently. From the therapeutic perspective they present the additional advantage of transducing non-dividing cells. From the manufacturing perspective lentiviral vectors present however, an additional difficulty as they contain cytotoxic proteins, requiring either the use of transient transfection or inducible systems. Both lentiviral and retroviral vectors are derived from virus belonging to the *retroviridae* family sharing many characteristics in terms of genome, biochemistry, structure and viral cycle. Thus many of the metabolic constraints in their production are common and reviewed herein.

The success of the application of retroviral vectors in phase I and II clinical trials is now moving the prospects to phase III trials. This will create momentum to increase the efforts in research related with retroviral vectors development and production due to the large amounts of vectors needed, and the stringent demands by the regulatory agencies. Lentiviral vectors in particular possess many of the characteristics of MLV retroviral vectors, and as mentioned present the additional advantages of being able to transduce quiescent cells. The diversity of human gene therapy as well as the possibility of patients being treated more than once with viral vectors, which are recognized by the adaptive immune system, leaves space to both alternative vector technologies. MLV present a large safety record in clinical application that cannot be discarded. Since MLV retroviral vectors are not derived from human viruses they also show reduced vector genome mobilization and recombination in the host-cell and pre-existing immune response against the retroviral vector particle. Additionally, they are simple to develop in terms of plasmid cloning, transfection and cell culture; and from the clinical perspective they can be easily produced at large scale from stable packaging cell lines with satisfactory yields. From the manufacturing point of view, HIV-1 derived vector still requires further optimization, particularly in what concerns cell line development. There is still less clinical experience with this vector and the results on the ongoing clinical trials will be certainly important for their improvement.

Thus the recent manufacturing strategies together with future innovations will certainly be important to increase productivity, stability, quality and safety of retroviral and lentiviral vectors for clinical applications.

5. Acknowledgements

The authors acknowledge the financial support received from the European Commission (CLINIGENE -LSHB-CT2006-018933) and the Fundação para a Ciência e a Tecnologia-Portugal (PTDC/EBB-BIO/100491/2008). Ana F. Rodrigues acknowledges FCT for her PhD grant (SFRH/BD/48393/2008).

6. References

Ahuja D, Saenz-Robles MT, Pipas JM. 2005. SV40 large T antigen targets multiple cellular pathways to elicit cellular transformation. *Oncogene* 24(52):7729-45.

- Aiuti A, Cattaneo F, Galimberti S, Benninghoff U, Cassani B, Callegaro L, Scaramuzza S, Andolfi G, Mirolo M, Brigida I and others. 2009. Gene therapy for immunodeficiency due to adenosine deaminase deficiency. *N Engl J Med* 360(5):447-58.
- Al-Dosari MS, Gao X. 2009. Nonviral gene delivery: principle, limitations, and recent progress. *Aaps J* 11(4):671-81.
- Alberts AW, Ferguson K, Hennessy S, Vagelos PR. 1974. Regulation of lipid synthesis in cultured animal cells. *J Biol Chem* 249(16):5241-9.
- Ansorge S, Lanthier S, Transfiguracion J, Durocher Y, Henry O, Kamen A. 2009. Development of a scalable process for high-yield lentiviral vector production by transient transfection of HEK293 suspension cultures. *J Gene Med* 11(10):868-76.
- Balaggan KS, Binley K, Esapa M, Iqball S, Askham Z, Kan O, Tschernutter M, Bainbridge JW, Naylor S, Ali RR. 2006. Stable and efficient intraocular gene transfer using pseudotyped EIAV lentiviral vectors. *J Gene Med* 8(3):275-85.
- Barger JF, Plas DR. 2010. Balancing biosynthesis and bioenergetics: metabolic programs in oncogenesis. *Endocr Relat Cancer* 17(4):R287-304.
- Beer C, Meyer A, Muller K, Wirth M. 2003. The temperature stability of mouse retroviruses depends on the cholesterol levels of viral lipid shell and cellular plasma membrane. *Virology* 308(1):137-46.
- Bender MA, Palmer TD, Gelinas RE, Miller AD. 1987. Evidence that the packaging signal of Moloney murine leukemia virus extends into the gag region. *J Virol* 61(5):1639-46.
- Blesch A. 2004. Lentiviral and MLV based retroviral vectors for ex vivo and in vivo gene transfer. *Methods* 33(2):164-72.
- Boussif O, Lezoualc'h F, Zanta MA, Mergny MD, Scherman D, Demeneix B, Behr JP. 1995. A versatile vector for gene and oligonucleotide transfer into cells in culture and in vivo: polyethylenimine. *Proc Natl Acad Sci U S A* 92(16):7297-301.
- Bray M, Prasad S, Dubay JW, Hunter E, Jeang KT, Rekosh D, Hammarskjold ML. 1994. A small element from the Mason-Pfizer monkey virus genome makes human immunodeficiency virus type 1 expression and replication Rev-independent. *Proc Natl Acad Sci U S A* 91(4):1256-60.
- Briggs JA, Wilk T, Fuller SD. 2003. Do lipid rafts mediate virus assembly and pseudotyping? *J Gen Virol* 84(Pt 4):757-68.
- Broussau S, Jabbour N, Lachapelle G, Durocher Y, Tom R, Transfiguracion J, Gilbert R, Massie B. 2008. Inducible packaging cells for large-scale production of lentiviral vectors in serum-free suspension culture. *Mol Ther* 16(3):500-7.
- Burns JC, Friedmann T, Driever W, Burrascano M, Yee JK. 1993. Vesicular stomatitis virus G glycoprotein pseudotyped retroviral vectors: concentration to very high titer and efficient gene transfer into mammalian and nonmammalian cells. *Proc Natl Acad Sci U S A* 90(17):8033-7.
- Carmo M, Alves A, Rodrigues AF, Coroadinha AS, Carrondo MJ, Alves PM, Cruz PE. 2009a. Stabilization of gammaretroviral and lentiviral vectors: from production to gene transfer. *J Gene Med* 11(8):670-8.
- Carmo M, Dias JD, Panet A, Coroadinha AS, Carrondo MJ, Alves PM, Cruz PE. 2009b. Thermosensitivity of the reverse transcription process as an inactivation mechanism of lentiviral vectors. *Hum Gene Ther* 20(10):1168-76.

- Carmo M, Panet A, Carrondo MJ, Alves PM, Cruz PE. 2008. From retroviral vector production to gene transfer: spontaneous inactivation is caused by loss of reverse transcription capacity. *J Gene Med* 10(4):383-91.
- Carrondo MJT, Merten OW, Haury M, Alves PM, Coroadinha AS. 2008. Impact of retroviral vector components stoichiometry on packaging cell lines: Effects on productivity and vector quality. *Human Gene Therapy* 19(2):199-210.
- Cavazzana-Calvo M, Hacein-Bey S, de Saint Basile G, Gross F, Yvon E, Nusbaum P, Selz F, Hue C, Certain S, Casanova JL and others. 2000. Gene therapy of human severe combined immunodeficiency (SCID)-X1 disease. *Science* 288(5466):669-72.
- Chan LM, Coutelle C, Themis M. 2001. A novel human suspension culture packaging cell line for production of high-titre retroviral vectors. *Gene Ther* 8(9):697-703.
- Chong H, Starkey W, Vile RG. 1998. A replication-competent retrovirus arising from a split-function packaging cell line was generated by recombination events between the vector, one of the packaging constructs, and endogenous retroviral sequences. *J Virol* 72(4):2663-70.
- Chong H, Vile RG. 1996. Replication-competent retrovirus produced by a 'split-function' third generation amphotropic packaging cell line. *Gene Ther* 3(7):624-9.
- Cockrell AS, Ma H, Fu K, McCown TJ, Kafri T. 2006. A trans-lentiviral packaging cell line for high-titer conditional self-inactivating HIV-1 vectors. *Mol Ther* 14(2):276-84.
- Coffin JM, Hughes SH, Varmus H. 1997. *Retroviruses*: Cold Spring Harbor.
- Cone RD, Mulligan RC. 1984. High-efficiency gene transfer into mammalian cells: generation of helper-free recombinant retrovirus with broad mammalian host range. *Proc Natl Acad Sci U S A* 81(20):6349-53.
- Cornetta K, Matheson L, Ballas C. 2005. Retroviral vector production in the National Gene Vector Laboratory at Indiana University. *Gene Ther* 12 Suppl 1:S28-35.
- Coroadinha AS, Gama-Norton L, Amaral AI, Hauser H, Alves PM, Cruz PE. 2010. Production of retroviral vectors: review. *Curr Gene Ther* 10(6):456-73.
- Coroadinha AS, Ribeiro J, Roldao A, Cruz PE, Alves PM, Merten OW, Carrondo MJ. 2006a. Effect of medium sugar source on the production of retroviral vectors for gene therapy. *Biotechnol Bioeng* 94(1):24-36.
- Coroadinha AS, Schucht R, Gama-Norton L, Wirth D, Hauser H, Carrondo MJ. 2006b. The use of recombinase mediated cassette exchange in retroviral vector producer cell lines: predictability and efficiency by transgene exchange. *J Biotechnol* 124(2):457-68.
- Coroadinha AS, Silva AC, Pires E, Coelho A, Alves PM, Carrondo MJ. 2006c. Effect of osmotic pressure on the production of retroviral vectors: Enhancement in vector stability. *Biotechnol Bioeng* 94(2):322-9.
- Cosset FL, Takeuchi Y, Battini JL, Weiss RA, Collins MK. 1995. High-titer packaging cells producing recombinant retroviruses resistant to human serum. *J Virol* 69(12):7430-6.
- Cruz PE, Carmo M, Coroadinha AS, Bengala A, Gonçalves D, Teixeira M, Merten O-W, Genny-Fiamma C, Carrondo MJT. Retroviral Vector Stability: Inactivation Kinetics and Membrane Properties. In: Gòdia F, Fussenegger M, editors. *Animal Cell Technology meets Genomics*; 2005. Springer. p 303-308.

- Cruz PE, Silva AC, Roldao A, Carmo M, Carrondo MJ, Alves PM. 2006. Screening of novel excipients for improving the stability of retroviral and adenoviral vectors. *Biotechnol Prog* 22(2):568-76.
- Danos O, Mulligan RC. 1988. Safe and efficient generation of recombinant retroviruses with amphotropic and ecotropic host ranges. *Proc Natl Acad Sci U S A* 85(17):6460-4.
- Davis JL, Witt RM, Gross PR, Hokanson CA, Jungles S, Cohen LK, Danos O, Spratt SK. 1997. Retroviral particles produced from a stable human-derived packaging cell line transduce target cells with very high efficiencies. *Hum Gene Ther* 8(12):1459-67.
- Delenda C. 2004. Lentiviral vectors: optimization of packaging, transduction and gene expression. *J Gene Med* 6 Suppl 1:S125-38.
- Dull T, Zufferey R, Kelly M, Mandel RJ, Nguyen M, Trono D, Naldini L. 1998. A third-generation lentivirus vector with a conditional packaging system. *J Virol* 72(11):8463-71.
- Eckert HG, Kuhlcke K, Schilz AJ, Lindemann C, Basara N, Fauser AA, Baum C. 2000. Clinical scale production of an improved retroviral vector expressing the human multidrug resistance 1 gene (MDR1). *Bone Marrow Transplant* 25 Suppl 2:S114-7.
- Edelstein M. 2010. *Gene Therapy Clinical Trials Worldwide* - <http://www.wiley.com//legacy/wileychi/genmed/clinical/>. Wiley InterScience.
- Eibl R, Kaiser S, Lombriser R, Eibl D. 2010. Disposable bioreactors: the current state-of-the-art and recommended applications in biotechnology. *Appl Microbiol Biotechnol* 86(1):41-9.
- Falkner E, Appl H, Eder C, Losert UM, Schoffl H, Pfaller W. 2006. Serum free cell culture: the free access online database. *Toxicol In Vitro* 20(3):395-400.
- Farson D, McGuinness R, Dull T, Limoli K, Lazar R, Jalali S, Reddy S, Pennathur-Das R, Broad D, Finer M. 1999. Large-scale manufacturing of safe and efficient retrovirus packaging lines for use in immunotherapy protocols. *J Gene Med* 1(3):195-209.
- Farson D, Witt R, McGuinness R, Dull T, Kelly M, Song J, Radeke R, Bukovsky A, Consiglio A, Naldini L. 2001. A new-generation stable inducible packaging cell line for lentiviral vectors. *Hum Gene Ther* 12(8):981-97.
- Gerin PA, Gilligan MG, Searle PF, Al-Rubeai M. 1999a. Improved titers of retroviral vectors from the human FLYRD18 packaging cell line in serum- and protein-free medium. *Hum Gene Ther* 10(12):1965-74.
- Gerin PA, Searle PF, Al-Rubeai M. 1999b. Production of retroviral vectors for gene therapy with the human packaging cell line FLYRD18. *Biotechnol Prog* 15(5):941-8.
- Ghani K, Cottin S, Kamen A, Caruso M. 2007. Generation of a high-titer packaging cell line for the production of retroviral vectors in suspension and serum-free media. *Gene Ther* 14(24):1705-11.
- Ghani K, Garnier A, Coelho H, Transfiguracion J, Trudel P, Kamen A. 2006. Retroviral vector production using suspension-adapted 293GPG cells in a 3L acoustic filter-based perfusion bioreactor. *Biotechnol Bioeng* 95(4):653-60.
- Gougeon ML. 2003. Apoptosis as an HIV strategy to escape immune attack. *Nat Rev Immunol* 3(5):392-404.
- Gruh I, Wunderlich S, Winkler M, Schwanke K, Heinke J, Blomer U, Ruhparwar A, Rohde B, Li RK, Haverich A and others. 2008. Human CMV immediate-early enhancer: a useful tool to enhance cell-type-specific expression from lentiviral vectors. *J Gene Med* 10(1):21-32.

- Higashikawa F, Chang L. 2001. Kinetic analyses of stability of simple and complex retroviral vectors. *Virology* 280(1):124-31.
- Ikeda Y, Takeuchi Y, Martin F, Cosset FL, Mitrophanous K, Collins M. 2003. Continuous high-titer HIV-1 vector production. *Nat Biotechnol* 21(5):569-72.
- Jordan M, Wurm F. 2004. Transfection of adherent and suspended cells by calcium phosphate. *Methods* 33(2):136-43.
- Kafri T, van Praag H, Ouyang L, Gage FH, Verma IM. 1999. A packaging cell line for lentivirus vectors. *J Virol* 73(1):576-84.
- Kaptein LC, Greijer AE, Valerio D, van Beusechem VW. 1997. Optimized conditions for the production of recombinant amphotropic retroviral vector preparations. *Gene Ther* 4(2):172-6.
- Kotani H, Newton PB, 3rd, Zhang S, Chiang YL, Otto E, Weaver L, Blaese RM, Anderson WF, McGarrity GJ. 1994. Improved methods of retroviral vector transduction and production for gene therapy. *Hum Gene Ther* 5(1):19-28.
- Kotsopoulou E, Kim VN, Kingsman AJ, Kingsman SM, Mitrophanous KA. 2000. A Rev-independent human immunodeficiency virus type 1 (HIV-1)-based vector that exploits a codon-optimized HIV-1 gag-pol gene. *J Virol* 74(10):4839-52.
- Kuate S, Wagner R, Uberla K. 2002. Development and characterization of a minimal inducible packaging cell line for simian immunodeficiency virus-based lentiviral vectors. *J Gene Med* 4(4):347-55.
- Le Doux JM, Davis HE, Morgan JR, Yarmush ML. 1999. Kinetics of retrovirus production and decay. *Biotechnol Bioeng* 63(6):654-62.
- Lee SG, Kim S, Robbins PD, Kim BG. 1996. Optimization of environmental factors for the production and handling of recombinant retrovirus. *Appl Microbiol Biotechnol* 45(4):477-483.
- Lesch HP, Laitinen A, Peixoto C, Vicente T, Makkonen KE, Laitinen L, Pikkarainen JT, Samaranayake H, Alves PM, Carrondo MJ and others. 2011. Production and purification of lentiviral vectors generated in 293T suspension cells with baculoviral vectors. *Gene Ther*.
- Lesch HP, Turpeinen S, Niskanen EA, Mahonen AJ, Airene KJ, Yla-Herttuala S. 2008. Generation of lentivirus vectors using recombinant baculoviruses. *Gene Ther* 15(18):1280-6.
- Lewis P, Hensel M, Emerman M. 1992. Human immunodeficiency virus infection of cells arrested in the cell cycle. *Embo J* 11(8):3053-8.
- Liberatore C, Capanni M, Albi N, Volpi I, Urbani E, Ruggeri L, Mencarelli A, Grignani F, Velardi A. 1999. Natural killer cell-mediated lysis of autologous cells modified by gene therapy. *J Exp Med* 189(12):1855-62.
- Loew R, Meyer Y, Kuehlcke K, Gama-Norton L, Wirth D, Hauser H, Stein S, Grez M, Thornhill S, Thrasher A and others. 2009. A new PG13-based packaging cell line for stable production of clinical-grade self-inactivating gamma-retroviral vectors using targeted integration. *Gene Ther* 17(2):272-80.
- Loew R, Selevsek N, Fehse B, von Laer D, Baum C, Fauser A, Kuehlcke K. 2004. Simplified generation of high-titer retrovirus producer cells for clinically relevant retroviral vectors by reversible inclusion of a lox-P-flanked marker gene. *Mol Ther* 9(5):738-46.

- Markowitz D, Goff S, Bank A. 1988. Construction of a safe and efficient retrovirus packaging cell line. *Adv Exp Med Biol* 241:35-40.
- Matukonis M, Li M, Molina RP, Paszkiet B, Kaleko M, Luo T. 2002. Development of second- and third-generation bovine immunodeficiency virus-based gene transfer systems. *Hum Gene Ther* 13(11):1293-303.
- McTaggart S, Al-Rubeai M. 2000. Effects of culture parameters on the production of retroviral vectors by a human packaging cell line. *Biotechnol Prog* 16(5):859-65.
- McTaggart S, Al-Rubeai M. 2002. Retroviral vectors for human gene delivery. *Biotechnol Adv* 20(1):1-31.
- Merten O, Landric L, Danos O. 2001. Influence of the metabolic status of packaging cells on retroviral vector production. *Recombinant Protein Production with Prokaryotic and Eukaryotic Cells*. Dordrecht: Kluwer Academic Publishers.
- Merten OW. 2004. State-of-the-art of the production of retroviral vectors. *J Gene Med* 6 Suppl 1:S105-24.
- Merten OW, Charrier S, Laroudie N, Fauchille S, Dugue C, Jenny C, Audit M, Zanta-Boussif MA, Chautard H, Radrizzani M and others. 2011. Large scale manufacture and characterisation of a lentiviral vector produced for clinical ex vivo gene therapy application. *Hum Gene Ther*.
- Miller AD, Buttimore C. 1986. Redesign of retrovirus packaging cell lines to avoid recombination leading to helper virus production. *Mol Cell Biol* 6(8):2895-902.
- Miller AD, Chen F. 1996. Retrovirus packaging cells based on 10A1 murine leukemia virus for production of vectors that use multiple receptors for cell entry. *J Virol* 70(8):5564-71.
- Miller AD, Garcia JV, von Suhr N, Lynch CM, Wilson C, Eiden MV. 1991. Construction and properties of retrovirus packaging cells based on gibbon ape leukemia virus. *J Virol* 65(5):2220-4.
- Mitrophanous K, Yoon S, Rohll J, Patil D, Wilkes F, Kim V, Kingsman S, Kingsman A, Mazarakis N. 1999. Stable gene transfer to the nervous system using a non-primate lentiviral vector. *Gene Ther* 6(11):1808-18.
- Mitta B, Rimann M, Fussenegger M. 2005. Detailed design and comparative analysis of protocols for optimized production of high-performance HIV-1-derived lentiviral particles. *Metab Eng* 7(5-6):426-36.
- Molina RP, Ye HQ, Brady J, Zhang J, Zimmerman H, Kaleko M, Luo T. 2004. A synthetic Rev-independent bovine immunodeficiency virus-based packaging construct. *Hum Gene Ther* 15(9):865-77.
- Naldini L, Blomer U, Gallay P, Ory D, Mulligan R, Gage FH, Verma IM, Trono D. 1996. In vivo gene delivery and stable transduction of nondividing cells by a lentiviral vector. *Science* 272(5259):263-7.
- Ni Y, Sun S, Oparaocha I, Humeau L, Davis B, Cohen R, Binder G, Chang YN, Slepishkin V, Dropulic B. 2005. Generation of a packaging cell line for prolonged large-scale production of high-titer HIV-1-based lentiviral vector. *J Gene Med* 7(6):818-34.
- Nie Z, Bren GD, Vlahakis SR, Schimnich AA, Brenchley JM, Trushin SA, Warren S, Schnepfle DJ, Kovacs CM, Loutfy MR and others. 2007. Human immunodeficiency virus type 1 protease cleaves procaspase 8 in vivo. *J Virol* 81(13):6947-56.
- Nie Z, Phenix BN, Lum JJ, Alam A, Lynch DH, Beckett B, Krammer PH, Sekaly RP, Badley AD. 2002. HIV-1 protease processes procaspase 8 to cause mitochondrial release of

- cytochrome c, caspase cleavage and nuclear fragmentation. *Cell Death Differ* 9(11):1172-84.
- Ott MG, Schmidt M, Schwarzwaelder K, Stein S, Siler U, Koehl U, Glimm H, Kuhlcke K, Schilz A, Kunkel H and others. 2006. Correction of X-linked chronic granulomatous disease by gene therapy, augmented by insertional activation of MDS1-EVI1, PRDM16 or SETBP1. *Nat Med* 12(4):401-9.
- Pacchia AL, Adelson ME, Kaul M, Ron Y, Dougherty JP. 2001. An inducible packaging cell system for safe, efficient lentiviral vector production in the absence of HIV-1 accessory proteins. *Virology* 282(1):77-86.
- Pandya S, Boris-Lawrie K, Leung NJ, Akkina R, Planelles V. 2001. Development of an Rev-independent, minimal simian immunodeficiency virus-derived vector system. *Hum Gene Ther* 12(7):847-57.
- Pauwels K, Gijssbers R, Toelen J, Schambach A, Willard-Gallo K, Verheust C, Debysers Z, Herman P. 2009. State-of-the-art lentiviral vectors for research use: risk assessment and biosafety recommendations. *Curr Gene Ther* 9(6):459-74.
- Perelson AS, Neumann AU, Markowitz M, Leonard JM, Ho DD. 1996. HIV-1 dynamics in vivo: virion clearance rate, infected cell life-span, and viral generation time. *Science* 271(5255):1582-6.
- Persons DA, Mehaffey MG, Kaleko M, Nienhuis AW, Vanin EF. 1998. An improved method for generating retroviral producer clones for vectors lacking a selectable marker gene. *Blood Cells Mol Dis* 24(2):167-82.
- Pizzato M, Merten OW, Blair ED, Takeuchi Y. 2001. Development of a suspension packaging cell line for production of high titre, serum-resistant murine leukemia virus vectors. *Gene Ther* 8(10):737-45.
- Poeschla EM, Wong-Staal F, Looney DJ. 1998. Efficient transduction of nondividing human cells by feline immunodeficiency virus lentiviral vectors. *Nat Med* 4(3):354-7.
- Przybylowski M, Hakakha A, Stefanski J, Hodges J, Sadelain M, Riviere I. 2006. Production scale-up and validation of packaging cell clearance of clinical-grade retroviral vector stocks produced in cell factories. *Gene Ther* 13(1):95-100.
- Rawat SS, Viard M, Gallo SA, Rein A, Blumenthal R, Puri A. 2003. Modulation of entry of enveloped viruses by cholesterol and sphingolipids (Review). *Mol Membr Biol* 20(3):243-54.
- Reeves L, Smucker P, Cornetta K. 2000. Packaging cell line characteristics and optimizing retroviral vector titer: the National Gene Vector Laboratory experience. *Hum Gene Ther* 11(15):2093-103.
- Rigg RJ, Chen J, Dando JS, Forestell SP, Plavec I, Bohnlein E. 1996. A novel human amphotropic packaging cell line: high titer, complement resistance, and improved safety. *Virology* 218(1):290-5.
- Roberts TM, Boris-Lawrie K. 2000. The 5' RNA terminus of spleen necrosis virus stimulates translation of nonviral mRNA. *J Virol* 74(17):8111-8.
- Rodrigues AF, Carmo M, Alves PM, Coroadinha AS. 2009. Retroviral vector production under serum deprivation: The role of lipids. *Biotechnol Bioeng* 104(6):1171-81.
- Rodrigues AF, Amaral AI, Veríssimo V, Alves PA, Coroadinha AS 2011. Adaptation to serum deprivation: implications in lipid biosynthesis and vector production (submitted)

- Rusert P, Fischer M, Joos B, Leemann C, Kuster H, Flepp M, Bonhoeffer S, Gunthard HF, Trkola A. 2004. Quantification of infectious HIV-1 plasma viral load using a boosted in vitro infection protocol. *Virology* 326(1):113-29.
- Sadettin SO, Hu W. 2006. Cell culture technology for pharmaceutical and cell-based therapies. Sadettin SO, Hu W, editors. Boca Raton, FL, USA: CRC Press Taylor & Francis Group
- Saenz DT, Poeschla EM. 2004. FIV: from lentivirus to lentivector. *J Gene Med* 6 Suppl 1:S95-104.
- Schnell T, Foley P, Wirth M, Munch J, Uberla K. 2000. Development of a self-inactivating, minimal lentivirus vector based on simian immunodeficiency virus. *Hum Gene Ther* 11(3):439-47.
- Schnierle BS, Stitz J, Bosch V, Nocken F, Merget-Millitzer H, Engelstadter M, Kurth R, Groner B, Cichutek K. 1997. Pseudotyping of murine leukemia virus with the envelope glycoproteins of HIV generates a retroviral vector with specificity of infection for CD4-expressing cells. *Proc Natl Acad Sci U S A* 94(16):8640-5.
- Schucht R, Coroadinha AS, Zanta-Boussif MA, Verhoeyen E, Carrondo MJ, Hauser H, Wirth D. 2006. A new generation of retroviral producer cells: predictable and stable virus production by Flp-mediated site-specific integration of retroviral vectors. *Mol Ther* 14(2):285-92.
- Schweizer M, Merten OW. 2010. Large-scale production means for the manufacturing of lentiviral vectors. *Curr Gene Ther* 10(6):474-86.
- Segura MM, Garnier A, Durocher Y, Ansorge S, Kamen A. 2010. New protocol for lentiviral vector mass production. *Methods Mol Biol* 614:39-52.
- Seth G, Philp RJ, Denoya CD, McGrath K, Stutzman-Engwall KJ, Yap M, Hu WS. 2005. Large-scale gene expression analysis of cholesterol dependence in NS0 cells. *Biotechnol Bioeng* 90(5):552-67.
- Sheridan PL, Bodner M, Lynn A, Phuong TK, DePolo NJ, de la Vega DJ, Jr., O'Dea J, Nguyen K, McCormack JE, Driver DA and others. 2000. Generation of retroviral packaging and producer cell lines for large-scale vector production and clinical application: improved safety and high titer. *Mol Ther* 2(3):262-75.
- Sinn PL, Sauter SL, McCray PB, Jr. 2005. Gene therapy progress and prospects: development of improved lentiviral and retroviral vectors--design, biosafety, and production. *Gene Ther* 12(14):1089-98.
- Smith SL, Shioda T. 2009. Advantages of COS-1 monkey kidney epithelial cells as packaging host for small-volume production of high-quality recombinant lentiviruses. *J Virol Methods* 157(1):47-54.
- Soneoka Y, Cannon PM, Ramsdale EE, Griffiths JC, Romano G, Kingsman SM, Kingsman AJ. 1995. A transient three-plasmid expression system for the production of high titer retroviral vectors. *Nucleic Acids Res* 23(4):628-33.
- Spector AA, Mathur SN, Kaduce TL, Hyman BT. 1980. Lipid nutrition and metabolism of cultured mammalian cells. *Prog Lipid Res* 19(3-4):155-86.
- Stewart HJ, Leroux-Carlucchi MA, Sion CJ, Mitrophanous KA, Radcliffe PA. 2009. Development of inducible EIAV-based lentiviral vector packaging and producer cell lines. *Gene Ther* 16(6):805-14.

- Swift S, Lorens J, Achacoso P, Nolan GP. 2001. Rapid production of retroviruses for efficient gene delivery to mammalian cells using 293T cell-based systems. *Curr Protoc Immunol* Chapter 10:Unit 10 17C.
- Swinnen JV, Brusselmans K, Verhoeven G. 2006. Increased lipogenesis in cancer cells: new players, novel targets. *Curr Opin Clin Nutr Metab Care* 9(4):358-65.
- Takeuchi Y, Cosset FL, Lachmann PJ, Okada H, Weiss RA, Collins MK. 1994. Type C retrovirus inactivation by human complement is determined by both the viral genome and the producer cell. *J Virol* 68(12):8001-7.
- Takeuchi Y, Liong SH, Bieniasz PD, Jager U, Porter CD, Friedman T, McClure MO, Weiss RA. 1997. Sensitization of rhabdo-, lenti-, and spumaviruses to human serum by galactosyl(alpha1-3)galactosylation. *J Virol* 71(8):6174-8.
- Takeuchi Y, Porter CD, Strahan KM, Preece AF, Gustafsson K, Cosset FL, Weiss RA, Collins MK. 1996. Sensitization of cells and retroviruses to human serum by (alpha 1-3) galactosyltransferase. *Nature* 379(6560):85-8.
- Throm RE, Ouma AA, Zhou S, Chandrasekaran A, Lockey T, Greene M, De Ravin SS, Moayeri M, Malech HL, Sorrentino BP and others. 2009. Efficient construction of producer cell lines for a SIN lentiviral vector for SCID-X1 gene therapy by concatemeric array transfection. *Blood* 113(21):5104-10.
- Toledo JR, Prieto Y, Oramas N, Sanchez O. 2009. Polyethylenimine-based transfection method as a simple and effective way to produce recombinant lentiviral vectors. *Appl Biochem Biotechnol* 157(3):538-44.
- Vu HN, Ramsey JD, Pack DW. 2008. Engineering of a stable retroviral gene delivery vector by directed evolution. *Mol Ther* 16(2):308-14.
- Wikstrom K, Blomberg P, Islam KB. 2004. Clinical grade vector production: analysis of yield, stability, and storage of gmp-produced retroviral vectors for gene therapy. *Biotechnol Prog* 20(4):1198-203.
- Wildner O, Candotti F, Krecko EG, Xanthopoulos KG, Ramsey WJ, Blaese RM. 1998. Generation of a conditionally neo(r)-containing retroviral producer cell line: effects of neo(r) on retroviral titer and transgene expression. *Gene Ther* 5(5):684-91.
- Xu K, Ma H, McCown TJ, Verma IM, Kafri T. 2001. Generation of a stable cell line producing high-titer self-inactivating lentiviral vectors. *Mol Ther* 3(1):97-104.
- Ye K, Dhiman HK, Suhan J, Schultz JS. 2003. Effect of pH on infectivity and morphology of ecotropic moloney murine leukemia virus. *Biotechnol Prog* 19(2):538-543.
- Yu JH, Schaffer DV. 2005. Advanced targeting strategies for murine retroviral and adeno-associated viral vectors. *Adv Biochem Eng Biotechnol* 99:147-67.
- Zufferey R, Donello JE, Trono D, Hope TJ. 1999. Woodchuck hepatitis virus posttranscriptional regulatory element enhances expression of transgenes delivered by retroviral vectors. *J Virol* 73(4):2886-92.
- Zufferey R, Nagy D, Mandel RJ, Naldini L, Trono D. 1997. Multiply attenuated lentiviral vector achieves efficient gene delivery in vivo. *Nat Biotechnol* 15(9):871-5.
- Zwolinska K. 2006. Retroviruses-derived sequences in the human genome. Human endogenous retroviruses (HERVs). *Postepy Hig Med Dosw (Online)* 60:637-52.

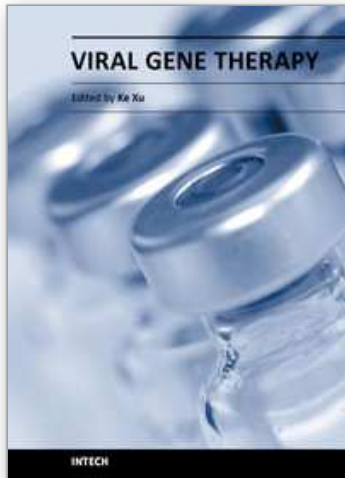

Viral Gene Therapy

Edited by Dr. Ke Xu

ISBN 978-953-307-539-6

Hard cover, 450 pages

Publisher InTech

Published online 20, July, 2011

Published in print edition July, 2011

The development of technologies that allow targeting of specific cells has progressed substantially in recent years for several types of vectors, particularly viral vectors, which have been used in 70% of gene therapy clinical trials. Particular viruses have been selected as gene delivery vehicles because of their capacities to carry foreign genes and their ability to efficiently deliver these genes associated with efficient gene expression. This book is designed to present the most recent advances in viral gene therapy

How to reference

In order to correctly reference this scholarly work, feel free to copy and paste the following:

Ana Rodrigues, Paula M. Alves and Ana Coroadinha (2011). Production of Retroviral and Lentiviral Gene Therapy Vectors: Challenges in the Manufacturing of Lipid Enveloped Virus, Viral Gene Therapy, Dr. Ke Xu (Ed.), ISBN: 978-953-307-539-6, InTech, Available from: <http://www.intechopen.com/books/viral-gene-therapy/production-of-retroviral-and-lentiviral-gene-therapy-vectors-challenges-in-the-manufacturing-of-lipi>

INTECH
open science | open minds

InTech Europe

University Campus STeP Ri
Slavka Krautzeka 83/A
51000 Rijeka, Croatia
Phone: +385 (51) 770 447
Fax: +385 (51) 686 166
www.intechopen.com

InTech China

Unit 405, Office Block, Hotel Equatorial Shanghai
No.65, Yan An Road (West), Shanghai, 200040, China
中国上海市延安西路65号上海国际贵都大饭店办公楼405单元
Phone: +86-21-62489820
Fax: +86-21-62489821

© 2011 The Author(s). Licensee IntechOpen. This chapter is distributed under the terms of the [Creative Commons Attribution-NonCommercial-ShareAlike-3.0 License](#), which permits use, distribution and reproduction for non-commercial purposes, provided the original is properly cited and derivative works building on this content are distributed under the same license.

IntechOpen

IntechOpen