

We are IntechOpen, the world's leading publisher of Open Access books Built by scientists, for scientists

4,800

Open access books available

122,000

International authors and editors

135M

Downloads

Our authors are among the

154

Countries delivered to

TOP 1%

most cited scientists

12.2%

Contributors from top 500 universities



WEB OF SCIENCE™

Selection of our books indexed in the Book Citation Index
in Web of Science™ Core Collection (BKCI)

Interested in publishing with us?
Contact book.department@intechopen.com

Numbers displayed above are based on latest data collected.

For more information visit www.intechopen.com



Anti-Multipath Filter with Multiple Correlators in GNSS Receivers

Chung-Liang Chang

*Department of Biomechatronics Engineering
National Pingtung University of Science and Technology
Pingtung County
Taiwan*

1. Introduction

The positioning technique of global navigation satellite system (GNSS) has become mature and also been applied to a variety of navigation vehicles, whether it be the application to ground vehicle or aircraft. Nevertheless, the precision of GNSS is susceptible to intentional or unintentional factors such as interference or jammer, etc. The influences range from minor effect like the positioning precision of satellite signal to significant impact like the misleading information to users or malfunction of receivers. The ionosphere or troposphere in environment or the noise in receiver itself are the source of positioning error when satellite passes through ionosphere or troposphere, the change of media results in the delay of wave transmission rate and yields error. The adoption of dual frequency receiver can decrease error but it presents no significant improvement in terms of the error generated by multipath.

The effect of multipath is because the satellite signal is reflected or diffracted by obstacle prior to its reception by antenna. Most of the time, it results in the decrease of signal propagation power and delay of time. In 1973, Hagerman employed conventional code tracking to analyze the effect of multipath on the coarse/acquire (C/A) code in carrier L1 using one chip of early-late spacing. He also estimated that under different delay, phase and signal magnitude, the effect may result in 70–80 m tracking error [Hagerman, 1973]. With the growing application of global positioning system (GPS), many researches investigating multipath effect have been proposed to effectively reduce its impact and have provided various estimation algorithms for implementation in hardware.

The most effective solution for multipath effect is the location of antenna. Assume the antenna is placed above the highest source reflection, the reflected signal will not be received. In antenna design, it can reduce the gain of received signal coming through lower elevation. Generally, the receiver will setup up the minimum elevation capable of receiving satellite signal. The design of choke ring antenna is used to mitigate multipath. The choke ring antenna circles the antenna with vertical concentric rings, whose function is to reduce the gain of received reflected signal. However, such a function is strongly related to the location of antenna.

In addition, the change of structure in internal correlator design of receiver is also a solution for multipath. The conventional GPS receiver typically adopts one chip early-late

spacing of correlator. The use of narrow correlator to reduce chip spacing can effectively mitigate multipath and noise, which cuts down the error of 70–80 m to 8–10 m (van Dierendonck et al., 1992). Note that the use of narrow correlator technique in coherent discriminator may lead to the lock failure in code delay locked loop without the cooperation of phase locked loop (PLL).

The strobe correlator and edge correlator are both solutions for multipath mitigation (Garin et al., 1996). The strobe correlator is implemented using two different narrow correlator discriminators. The strobe correlator and edge correlator developed by Ashtech only provide code correlation for C/A code. The enhanced strobe correlator (Garin and Rousseau, 1997) offers carrier phase correction and code correction for C/A code. With the additional carrier phase correction in terms of multipath its real-time dynamic processing outperforms previous methods. Note that the narrow correlator and strobe correlator do not encompass carrier phase correction. Thus, their sensitivity approaches that of conventional correlator.

Another discriminator design is early 1/ early 2 (E1/E2) correlator (Mattos, 1996; van Dierendonck and Braasch, 1997). The method utilizes part of correlation coefficients not subject to multipath effect for multipath mitigation. That is, it employs two correlators with the spacing and location at the front end of correlation function. However, this method is a choice between noise mitigation and multipath mitigation.

The multipath estimation method initial estimates multipath signal and then subtracts it from received signal so that the signal approaches direct signal. Literature review that resembles this algorithm are MEDLL, MET. (van Nee, 1992; van Nee et al., 1994), which utilize maximum likelihood estimation technique and recursive least square method to estimate the magnitude, delay, phase and erase it from received signal. Though the above estimation methods can not completely eliminate multipath signal, they present significant improvement in terms of multipath delay within certain range.

Nevertheless, these techniques have difficulties in mitigating short-delay multipath signals (less than 0.1 PN code chip or approximately 30 m). Scholars have proposed methods on short-delay multipath mitigation (Sleewaegen et al., 2001; Stone and Chansarkar, 2004). However, these techniques still have drawbacks. The method proposed by Sleewaegen requires a scaling factor, depending on multipath environment, to link the signal amplitude with the range error. The method proposed by Stone and Chansarkar is to estimate the pseudorange error on the basis of a statistical model, which requires large numbers of collected data. Consequently, the performances of these two methods are significantly influenced by multipath environment.

The author has proposed an adaptive filter in 2008 (Chang and Juang, 2008), which adopts five tap-delay to effectively mitigate short-delay multipath. Though this method is efficient in short-delay multipath mitigation, it does not guarantee that the receiver will not receive multipath signal at different time delay under variable environment. Moreover, the correlator technique of conventional receiver is not quite capable of accurately describing the data distribution of correlated signal, which results in longer period of time to estimate multipath parameter. Thus, this paper utilizes multi-correlator technique in combination with proposed method to mitigate the mystical multipath signal. Simulation results show that the multi-correlator technique can clearly present the output distribution of correlator, make adaptive filter rapidly estimate multipath parameter and cope with multipath signal at different time delay.

2. Methodology

2.1 Multipath overview

Multipath effect is caused by the reflection of satellite signal by obstacles when the receiver receives the reflected signal, it leads to positioning error and the lock failure of signal for receiver, which renders positioning function void. In GPS, the desired signal consist of only the direct path signal. All other signals distort the desired signal and result in ranging measurement errors. To understand the effect of multipath in measurement process, let's consider the heart of the GPS code tracking loop. The pseudorange measurement originates from a locally generated pseudorandom noise (PRN) code which is kept phase-locked to the received code. The discriminator is formed based on the difference between early correlator output and late correlator output. The output of the discriminator is fed back to the local code generator to keep synchronism between the local code and incoming code. This generatess the so-called delay-locked loop (DLL). When multipath is present, the incoming code, correlation function and discriminator functions are distorted. Analytically, the direct and multipath components may be conducted separately. Note that for the direct-path case, the discriminator function passes through zero when the code-tracking error (local-code delay) is zero. This is the ideal case. However, when multipath is present, the distorted function has a zero-crossing at non-zero code tracking error. Fig. 1 demonstrates the tracking errors of the early-late discriminator output due to multipath in the DLL. The tracking errors result from distortion of the correlation function with the received IF signal. In the direct-path case, the ideal case is when the discriminator function passes through zero while the code tracking error is zero. However, with the presence of multipath, the distorted function has a zero-crossing at a non-zero code tracking error. With the direct signal, when the relative multipath phase is 0 radians, the multipath component is 'in-phase'. With π radians, the multipath component is 'out-of phase'.

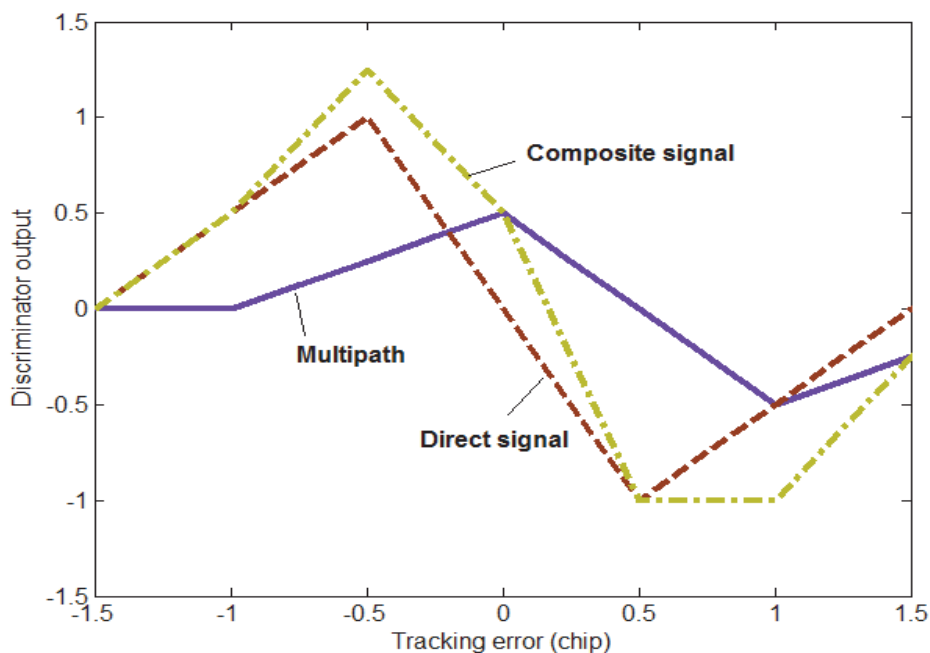

Fig. 1. Composite distorted of early-late discriminator.

Thus, pseudorange multipath analysis encompasses simulation of direct and indirect path signals and determination of zero-crossing of distorted discriminator function. There are three multipath parameters to consider: strength, delay and phase. The absolute value of each parameter is irrelevant. The upper and lower bounds of the multipath error can be determined, for a given multipath-to-direct ratio, by fixing the relative multipath phase at 0 and π radians, respectively, and varying the relative multipath delay. At each delay point, the distorted discriminator curve is determined and the resulting zero-crossing point and pseudorange error are calculated. The result of an example is presented in Fig. 2, which illustrates result of the theoretical multipath error envelope versus the multipath delay. The code autocorrelation sidelobes have been ignored. This simulation is offered in the case of 24 MHz bandwidth receiver filter, 1-chip, 0.5-chip, and 0.2-chip early-late (E-L) spacing and unaltered multipath amplitude. A conventional GPS receiver adopts a delay-lock loop with a 1-chip spacing between early and late correlators. The smaller E-L spacing is regarded as narrow-correlator architecture. Narrow-correlator receivers typically utilize spacings in the range of 0.05 to 0.2 PRN chips.

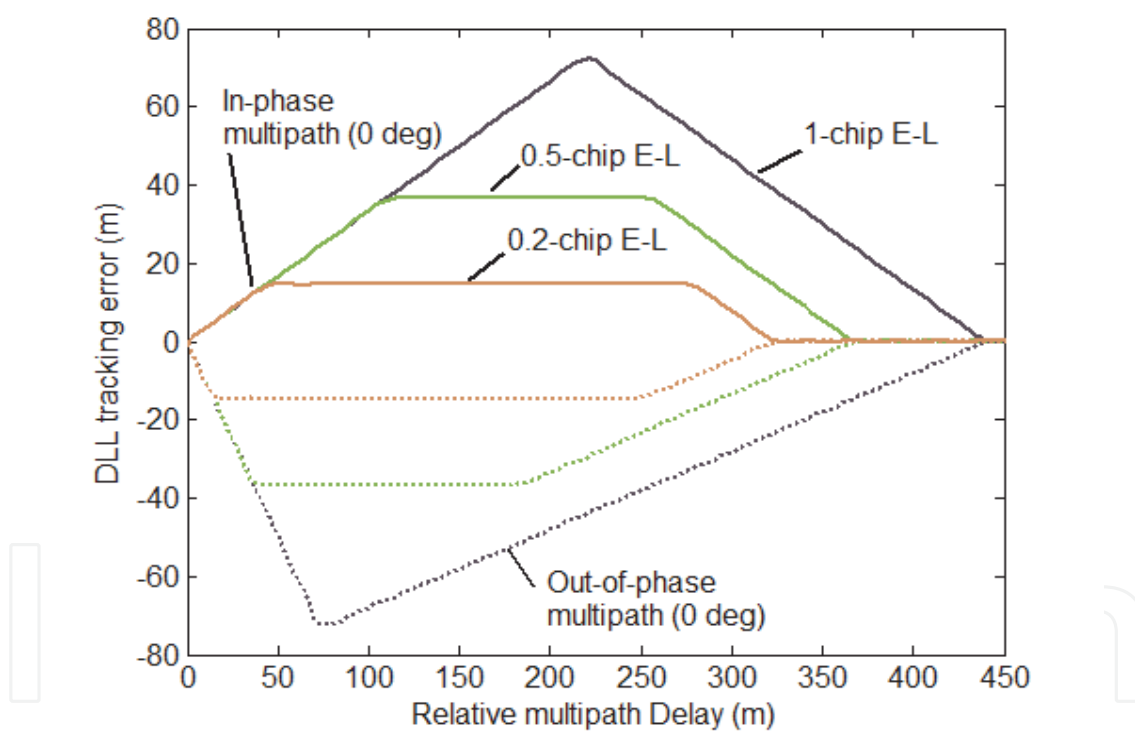

Fig. 2. Multipath error envelope for a conventional, 1-chip early-to-late (E-L), 0.5-chip E-L, and 0.2-chip E-L DLL receiver; Multipath component is half the strength of direct signal.

2.2 Signal model

A GPS receiver may receive a number of reflected signals and direct signal from the satellite. The error source of GPS consist of ionosphere delay, troposphere delay, receiver noise and multipath effect. Except for multipath, the other errors can be significantly decreased through advanced prediction and differential correction method. It is hard to depict the statistical model of the received signal in the presence of multipath. However,

many hypotheses can still be proposed. One hypothesis describes that the multipath signals are delayed with respect to direct GPS signal. Thus, let's consider only these reflected signals with a delay of less than one chip. This is because signals with a code delay larger than one chip are uncorrelated with the direct signals. Otherwise, the multipath signal is assumed to have the lower power than the direct one. The composite baseband signal, ignoring the navigation data bit, is given by

$$z[n] = \sum_{k=0}^M \alpha_k p(nT_s - \tau_k) \exp(-j(\omega nT_s + \theta_k)) + v[n] \quad (1)$$

where α_k , θ_k and τ_k denote amplitude, carrier phase, and code delay of k -th delayed signal. M represents the number of multipath component. $p(\bullet)$ indicates spread-spectrum code. ω denotes the IF angular frequency. The notation $z[n] = z(nT_s)$ is employed to denote a digital sequence sampled at the frequency $f_s = 1/T_s$ where T_s indicates period of sampling and n is the discrete time index. The 0-th delayed signal corresponds to the direct signal. $v[n]$ is modeled as white Gaussian noise distribution. The positioning error caused by the reception of multipath and direct signal is not only associated with the hardware design of receiver but also the detection algorithm. The literature review has provided several solutions for multipath effect. The following chapter will describe the proposed algorithm to counteract multipath.

2.3 Multiple correlator concept

The design of multi-correlator is seldom implemented due to the consideration of processing speed of hardware and cost. Owing to the promotion of hardware speed, decrease of cost and emergence of software wireless, the application of multi-correlator technique to receiver has become more prevalent. In fact, the strobe correlator described above is one of multi-correlator technique, which utilizes the linear combination of two correlators as discriminator output and adjusts chip spacing to track signal. Multi-correlator technique can depict the signal distribution after correlation process. In other words, this technique can present the process of correlation output in detail. Fig. 3 demonstrates the correlation output using 1 and 32 correlators, respectively. This figure illustrates that the multipath component can not be apparent if it adopts one set of correlator (early, prompt, and late). On the contrary, the 32 sets of correlator can better present the distribution of correlation output. Assume there are five correlators and the correlation of received signal is known. The linear combination of the five correlators can constitute received signal, which is expressed as:

$$v_j = \sum_{i=1}^Q r_{ji} u_i \quad (2)$$

v denotes each measurement value of correlator, Q indicates the number of correlator, r is corresponding correlation value and u is the scaled value of correlation center itself. Take the five correlators as example. Assume five correlators are located at -0.5, -0.25, 0, 0.25, 0.5, respectively. The combination of five correlators can be employed to accomplish the measurement value of each correlator. Equation (1) is rewritten as follows:

$$\begin{aligned}
 \mathbf{v} &= \mathbf{R}\boldsymbol{\Lambda} \\
 \Rightarrow \begin{bmatrix} 0.5 \\ 0.75 \\ 1 \\ 0.75 \\ 0.5 \end{bmatrix} &= \begin{bmatrix} 1 & 0.75 & 0.5 & 0.25 & 0 \\ 0.75 & 1 & 0.75 & 0.5 & 0.25 \\ 0.5 & 0.75 & 1 & 0.75 & 0.5 \\ 0.25 & 0.5 & 0.75 & 1 & 0.75 \\ 0 & 0.25 & 0.5 & 0.75 & 1 \end{bmatrix} \begin{bmatrix} 0 \\ 0 \\ 1 \\ 0 \\ 0 \end{bmatrix} \quad (3)
 \end{aligned}$$

The makeup of \mathbf{v} is constituted by third correlator (location as 0) because the $\boldsymbol{\Lambda}$ of the rest correlators is 0. The makeup of \mathbf{R} is based on the location of selected correlator. With the \mathbf{v} and \mathbf{R} matrix known a priori, the magnitude of the signal in terms of the distribution set up by correlator can be known based on $\boldsymbol{\Lambda} = \mathbf{R}^{-1}\mathbf{v}$. The more the correlators, the clearer the distribution of the signal.

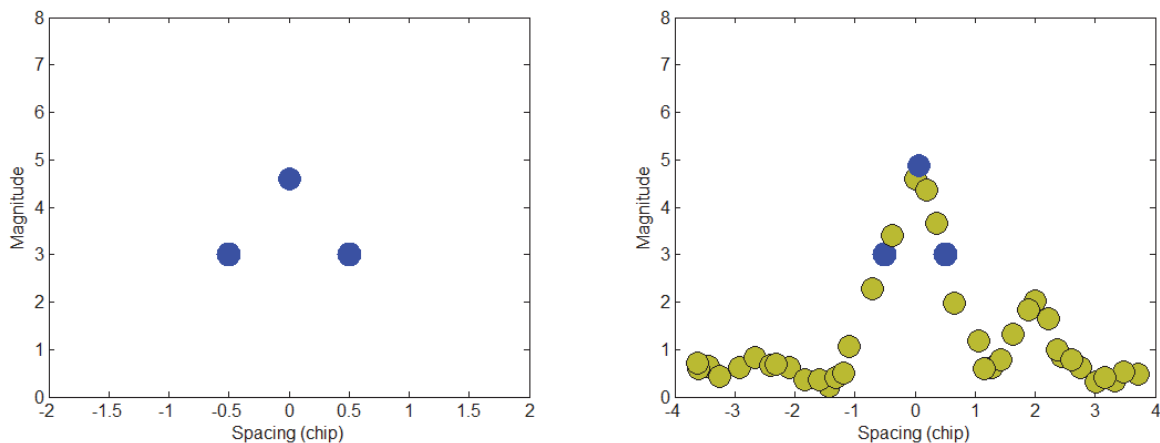

Fig. 3. Comparison of single correlator and multi-correlator.

It is known that the multi-correlator can depict the makeup of signal. Thus, we will see if multi-correlator can estimate direct signal with the direct signal plus multipath signal. Assume the multipath delay as 0.25 chip, signal magnitude as 0.5 and five correlators are shown as Fig. 4. Based on $\boldsymbol{\Lambda} = \mathbf{R}^{-1}\mathbf{v}$, the distribution of signal is known. Apparently, a correlation value exists between third and fourth correlator and the $\boldsymbol{\Lambda}$ of fourth correlator is lower. Using the negative correlation value from fourth correlator, we can eliminate multipath. Fig. 5 illustrates the multipath mitigation when the location of time delay is at the location of set multi-correlator.

$$\begin{aligned}
 \boldsymbol{\Lambda} &= \mathbf{R}^{-1}\mathbf{v} \\
 &= \begin{bmatrix} 1 & 0.75 & 0.5 & 0.25 & 0 \\ 0.75 & 1 & 0.75 & 0.5 & 0.25 \\ 0.5 & 0.75 & 1 & 0.75 & 0.5 \\ 0.25 & 0.5 & 0.75 & 1 & 0.75 \\ 0 & 0.25 & 0.5 & 0.75 & 1 \end{bmatrix}^{-1} \begin{bmatrix} 0.625 \\ 1 \\ 1.375 \\ 1.25 \\ 0.875 \end{bmatrix} \approx \begin{bmatrix} 0 \\ 0 \\ 1 \\ 0.5 \\ 0 \end{bmatrix} \quad (4)
 \end{aligned}$$

When the multipath delay is not at the set correlator, the calculated value after the above deduction approximates direct signal with little gap. Fig. 6 demonstrates the scenario when the location of multipath time delay is not at the location of set correlator.

$$\Lambda = R^{-1}v$$

$$= \begin{bmatrix} 1 & 0.75 & 0.5 & 0.25 & 0 \\ 0.75 & 1 & 0.75 & 0.5 & 0.25 \\ 0.5 & 0.75 & 1 & 0.75 & 0.5 \\ 0.25 & 0.5 & 0.75 & 1 & 0.75 \\ 0 & 0.25 & 0.5 & 0.75 & 1 \end{bmatrix}^{-1} \begin{bmatrix} 0.55 \\ 0.925 \\ 1.3 \\ 1.175 \\ 0.95 \end{bmatrix} \approx \begin{bmatrix} 0 \\ 0 \\ 1 \\ 0.2 \\ 0.3 \end{bmatrix} \quad (5)$$

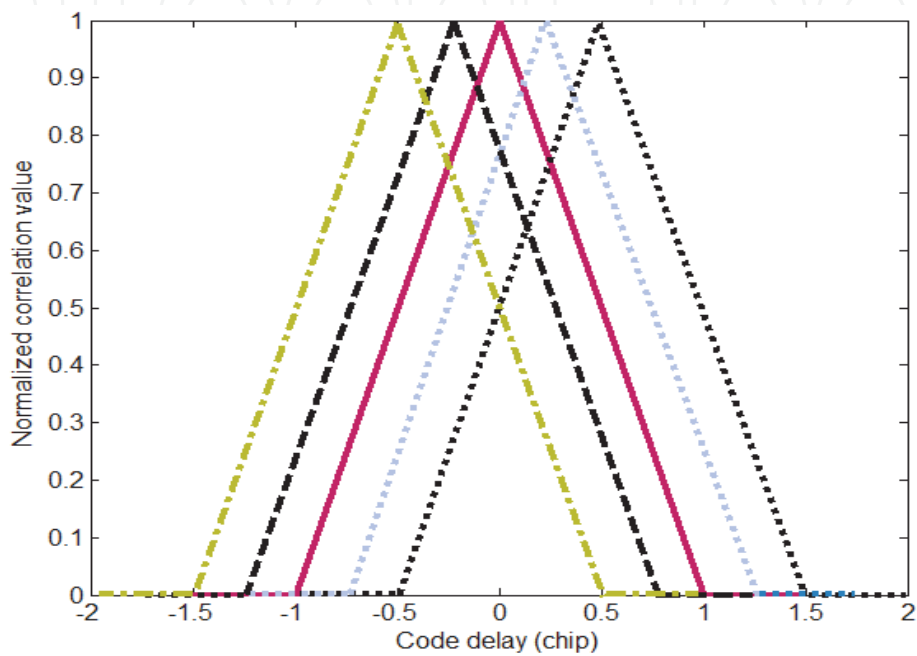

Fig. 4. Distribution of five correlators.

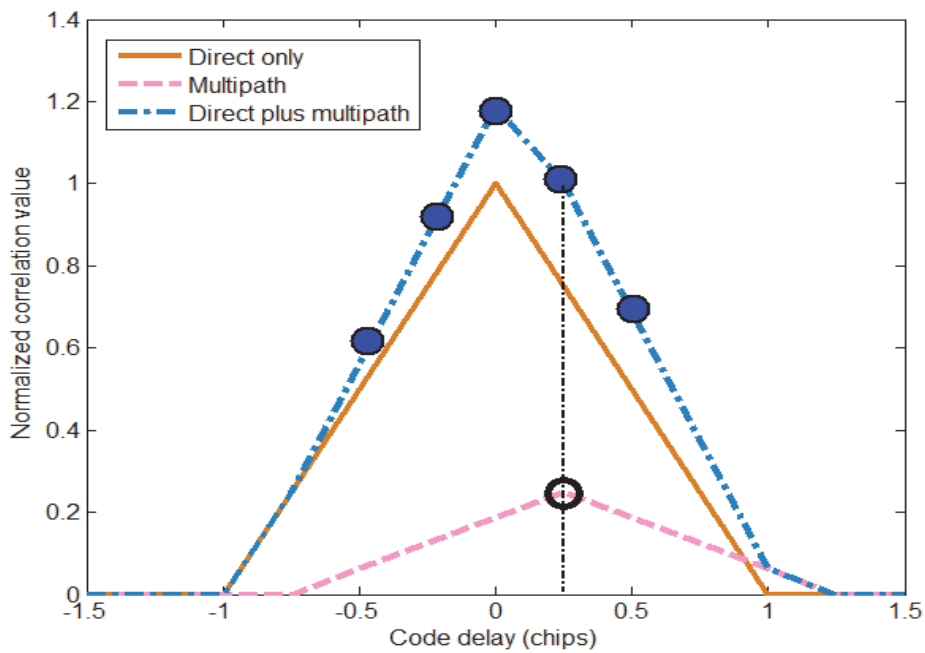

Fig. 5. Multipath delay is at the set correlator.

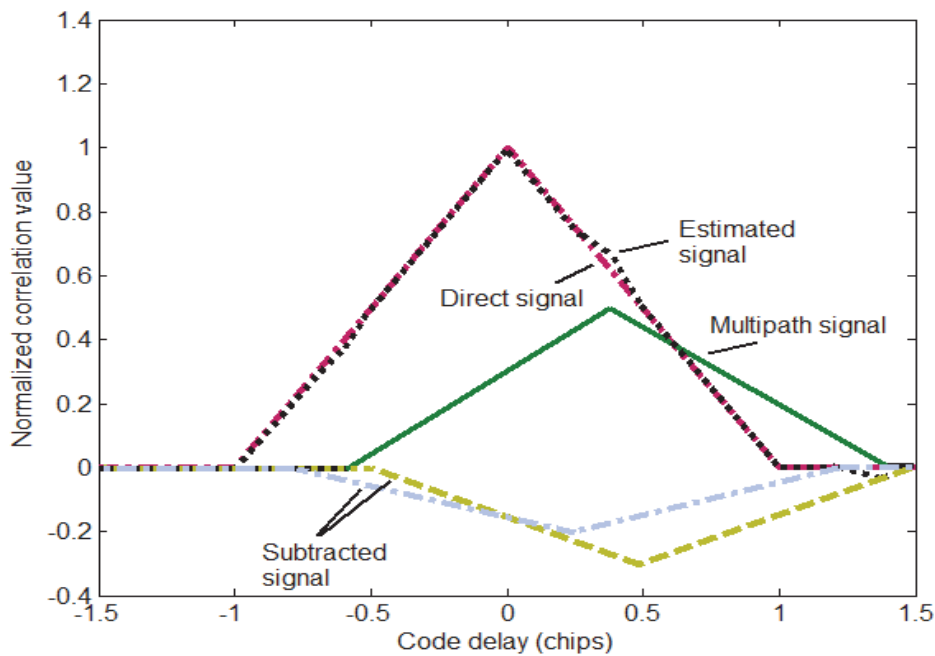

Fig. 6. Multipath delay is not at the set correlator.

2.4 Anti-multipath filter with multiple correlator

The previous chapter has clearly presented the advantage of multi-correlator method and its operation process. This chapter will elaborate how to constitute an anti-multipath filter based on multi-correlator. Fig. 5 shows the block diagram of the multipath mitigation system. The received signal is processed in a RF filter, then downconverted and sampled to a digital IF signal.

The tracking module consists of multiple correlator, code/carrier generator, discriminator and filter. The purpose of this module is to acquire accurate code phase and the carrier phase from PLL and DLL. The multipath estimator is used to estimate the correlation parameter of multipath, on the basis of the adaptive filter by employing duplicated signal and digital IF signal. Fig. 7 demonstrates that the estimated signal parameters are sent to the

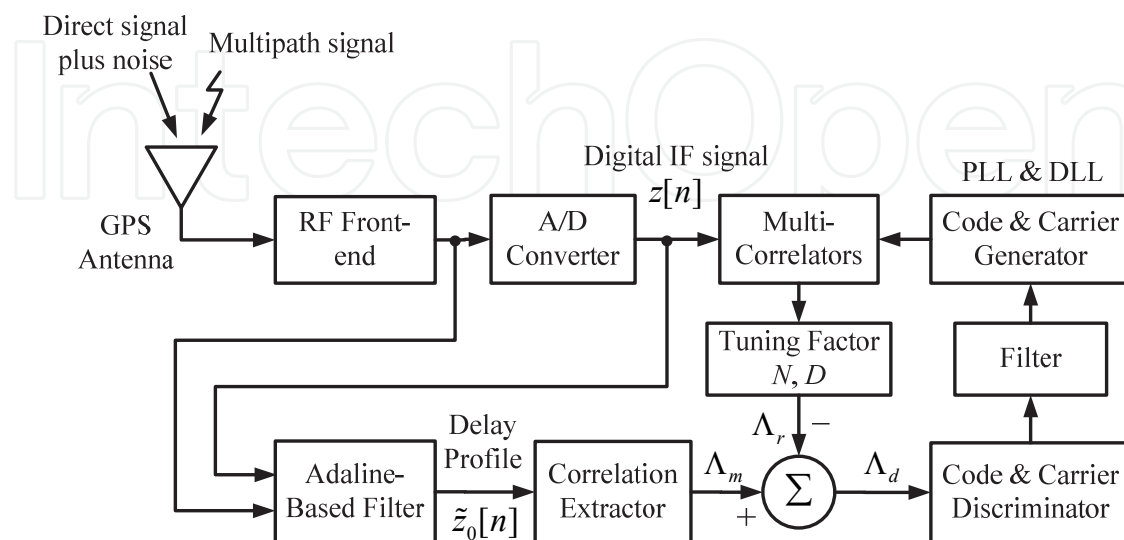

Fig. 7. Multipath Mitigation System Block Diagram.

correlation decomposer and the correlation value of multipath signal is determined in the multipath cancellation area.

The estimated delayed signal is recreated at the Adaline-based filter and is subtracted from the correlation value of the received signal. The process of multi-correlators, multipath estimator, correlation value decomposer, and multipath cancellation will be elaborated in the following subsections.

2.4.1 Multi-correlators techniques

The concept of multi-correlator and the process of this method have been detailed in previous chapter. What we consider for the time being is that initial point of code delay of received signal and the local replica is not identical and multipath does not take place at the set correlator. Thus, parallel shift method is utilized to change the element of R matrix, such as shift the correlator location. Based on the simulation, assume the code shift of received signal as 0.3 chip and multipath delay as 0.5 chip. Using the above method, we add two variable as shift times N and shift range D , respectively. The purpose is to acquire the received direct signal and counteract multipath. The circle in red in the following figure are the code shift of direct signal, the shift times and range of correlator. The following will present the process. Fig. 8 (a) denotes the correlator output without shift operation. The color green is direct signal, the dark brown is multipath and the brown denotes composite signal. Afterward, the correlator is shifted 0.1 chip ($N=1$ and $D=0.1$), and Fig. 8 (b) is derived. However, this figure reveals that the performance does not meet our expectation. Fig 8(c) illustrates that after shift 0.3 chip ($N=1$ and $D=0.3$), the brown signal and green direct signal almost overlaps. The program is to simulate the location of set correlator in order to acquire v . Through the variation of R , multipath is mitigated. The result presents that acquired signal of correlator output using parallel shift method (shift 0.3 chip) is a more efficient strategy in multipath mitigation as opposed to shift 0.1 chip without shift.

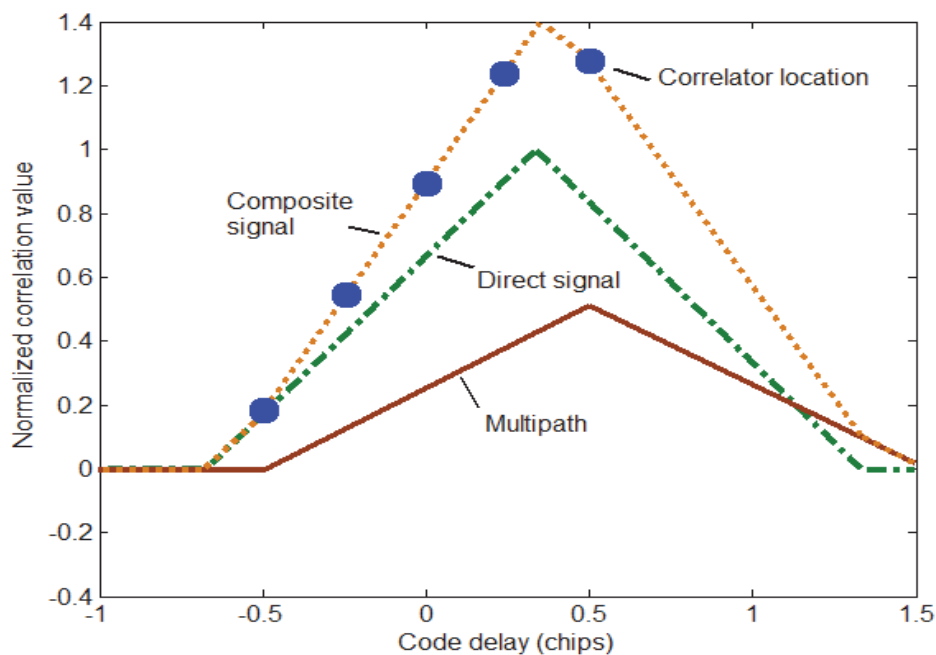

(a)

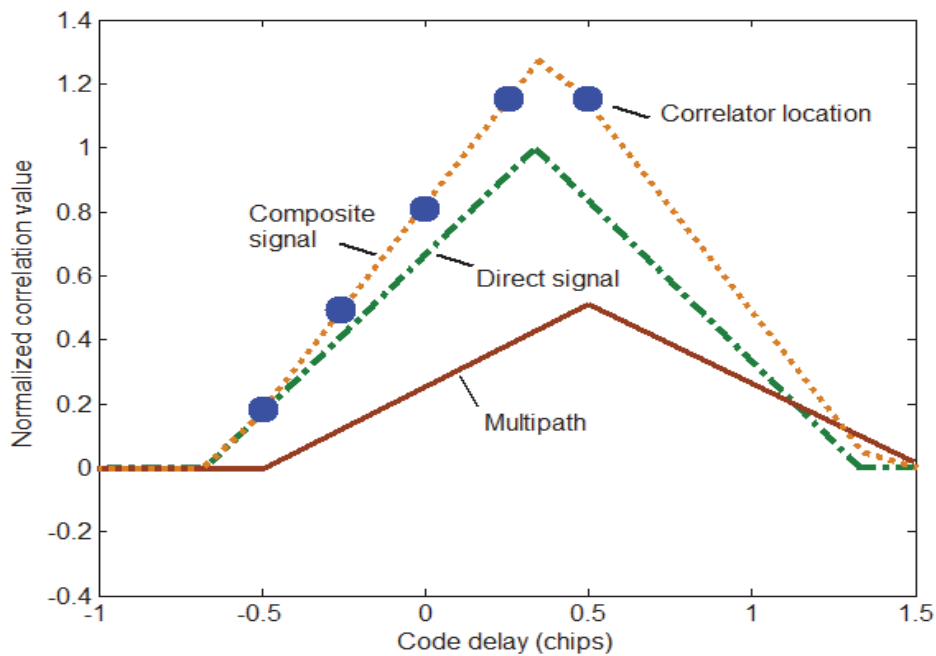

(b)

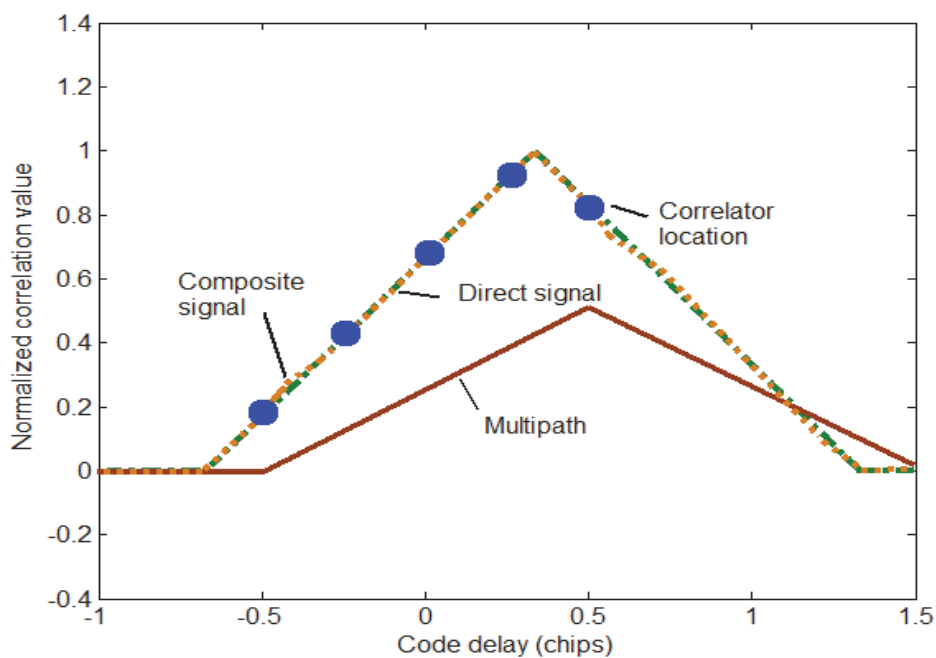

(c)

Fig. 8. Multi-correlators technique simulation results. (a) $N=0$, $D=0.1$ (b) $N=1$, $D=0.1$ (c) $N=3$, $D=0.1$.

2.4.2 Adaline-based filter

The function of a multipath estimator is to estimate the multipath delay using Adaline-based filter, shown in Fig. 9. It adopts the tap-delay line with an Adaline network (Widrow and Hoff, 1960) to constitute this structure without a non-linear element. An adaptive

algorithm such as the LMS algorithm or the Back-Propagation (BP) learning algorithm is often employed to adjust the weights of the Adaline so that it responds accurately to as many patterns as possible in a training set. It is the simplest and most intelligent self-learning system which adapts itself to achieve an optimal solution (Rumelhart, D. E. et al, 1986). In this paper, the BP with an adaptive learning rate algorithm serves as a substitute for the LMS algorithm so as to prevent inherent limitations in LMS and to improve filter convergence rate (Schalkoff, R. J., 1997). The multipath estimator offers the multipath delay profile. Suppose the estimated digital IF signal is given by:

$$\tilde{z}[n] = \sum_{k=0}^{\tilde{M}} \tilde{\alpha}_k p(nT_s - \tilde{\tau}_k) \exp(-j(\omega nT_s + \tilde{\theta}_k)) + v[n] \quad (6)$$

Where the parameter with the symbol “ \sim ” denotes the estimated parameter. A reference signal is a replica of code and carrier deriving from the output of DLL and PLL, which is shown as:

$$c_k[n] = p(nT_s - kd_r - \varepsilon_r) \exp(-j(\omega nT_s - \varepsilon_\theta)) \quad (k = 0, \dots, K) \quad (7)$$

where ε_r and ε_θ denote the measured group delay and carrier phase consisting of multipath error. d_r indicates sample period of delay of the multipath signals and Kd_r denotes the maximum delay of multipath signals. It is difficult to determine the parameters directly without any assumption about multipath signals. Thus, (6) is adopted in estimation process and modified by using reference signal and replacing \tilde{M} with \tilde{K} where the output signal of the filter is expressed as:

$$\tilde{z}[n] = \sum_{k=0}^{\tilde{K}} w_k c_k[n] + w_b c_b + \tilde{v}[n] \quad (8)$$

where $w_k = \tilde{\alpha}_k \exp(j\tilde{\theta}_k)$ represents the adjustable weight. The filter weight is employed to minimize the cost function, called squared error energy function and defined by using Equation (1) and (6):

$$L[n] = E\{(z[n] - \tilde{z}[n])(z[n] - \tilde{z}[n])^H\} \quad (9)$$

The filter minimizing the cost function is chosen by its tap weights to be the optimal solution to the normal equation (Haykin, S., 1986).

$$w_k^{\text{opt}} = C_k g_k^{-1}, \quad (10)$$

where C_k denotes the autocorrelation, $E\{x_i[n]x_k^H[n]\}$, of two reference signals ($c_i[n]$ and $c_k[n]$). g is the cross-correlation, $E\{z[n]c_i^H[n]\}$, of the digital IF signal $z[n]$ and reference signal $c_i[n]$. Where $E\{\bullet\}$ indicates an expectation operator. The filter solves (10) recursively using the BP with adaptive learning rate algorithm. This learning rule performs a gradient descent on the energy function to derive a minimum:

$$\begin{aligned} w_k[n] &= w_k[n-1] + \mu\delta[n-1]c_k[n-1], \\ w_b[n] &= w_b[n-1] + \mu\delta[n-1]c_b \end{aligned} \quad (11)$$

where $\delta[n]$ denotes the output layer error term. $\tilde{\alpha}_k$, $\tilde{\theta}_k$, and $\tilde{\tau}_k$ are estimated as the absolute value of weight $|w_k|$, the phase angle of weight $\arg(w_k)$ and the value of delay element kd_τ , respectively. The bias weight w_b connected to a constant input $c_b = +1$, effectively controls the input signal level of the filter. Note that the digital IF signal given in (1) is adopted as the desired signal and the output of DLL and PLL serves as the filter input signal. The reference signal is determined by (7) which generates the output of each delay element. Therefore, the estimated delay parameters from the filter weights and the delay element can be derived on condition that the learning algorithm has converged. The learning rate coefficient μ determines stability and convergence rate and a BP trained reference signal is adopted to obtain the minimum of (9) (Widrow 1986; Jacobs 1988). Suppose the learning rate is too large, the search path will oscillate about the desired path and converge more slowly than a direct descent. Nevertheless, the descent will progress in small steps if the learning rate is too small. It will greatly significantly increases the total time to convergence. Consequently, an adaptive coefficient where the value of μ is a function of the error derivation is adopted as the solution (Schalkoff, R. J., 1997).

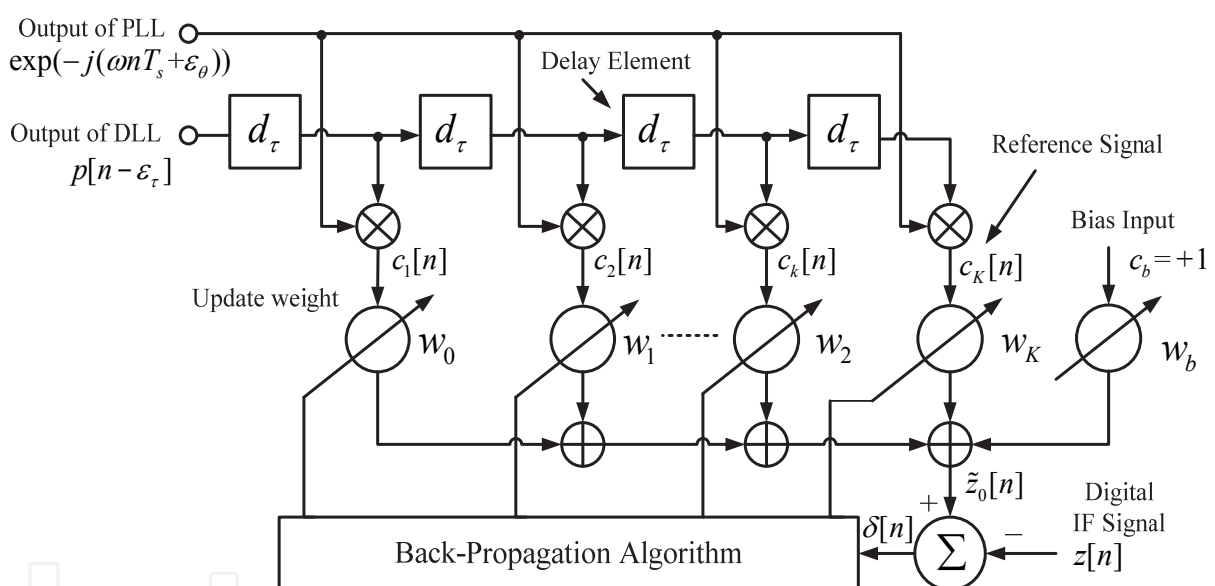

Fig. 9. Structure of the Adaline-based filter used in the multipath estimator.

2.4.3 Correlation extractor

After the use of adaptive filter, the estimated parameters can be obtained and the correlation decomposer divides the estimated parameters into multipath and direct signal. Besides, the autocorrelation function of multipath signals is subtracted from analog-to-digital (A/D) converter output of the received signal. In the decomposer process, it is assumed that the values of the first peak amplitude tap weight are the direct signal and the remainders are multipath signals. Fig. 5 presents an example where the direct signals refers to the first peak $k = l$ and the multipath signal amplitude denotes the remnants $l < k \leq K$. Suppose that the multipath channel has a decreasing power delay profile. The multipath signal parameter is adopted to calculate the correlation value. The correlation equation of estimated multipath signals with amplitude $\tilde{\alpha}_k$, delay $\tilde{\tau}_k$ and carrier phase $\tilde{\theta}_k$ is written as:

$$\Lambda_k(\tau) = \tilde{A}_k C(\tau - \tilde{\tau}_k) \cos(\tilde{\theta}_l - \tilde{\theta}_k), \quad (12)$$

where $C(\tau)$ denotes the autocorrelation function of the GPS PRN (Pseudo Random Noise) code signal.

$$E\{p[n]p[n-\tau]\} \quad (13)$$

Hence, the entire correlation value of the estimated multipath signal $\Lambda_k(\tau)$ is given by:

$$\Lambda_m(\tau) = \sum_{k=1}^{\tilde{K}} \Lambda_k(\tau) \quad (14)$$

2.4.4 Multipath removal

The entire correlation values of multipath signal Λ_m are subtracted from the correlation value of received signal Λ_r and the output of correlation value Λ_d is expressed as:

$$\Lambda_d(\tau) = \Lambda_r(\tau) - \Lambda_m(\tau) \quad (15)$$

In (12), the estimated correlation Λ_r of direct signal can be acquired using multi-correlator technique. Such a technique has been detailed in chapter 2.3.1. Multi-correlator technique can effectively estimate the correlation of direct signal and counteract multipath simultaneously. It can promote the convergence speed of Adaline-based filter.

The tracking error takes place in DLL and PLL due to the multipath effect. The effect primarily results from distortion of the correlation function receiving the IF signal, shown in Fig. 8(a), which illustrates the normalized correlation function with multipath effect. Fig. 8(a) presents that the symmetry is lost and the propagation delay is difficult to estimate. Thus, the range measurement accuracy is diminished. Nevertheless, the use of a subtractive method offers multipath mitigation in the tracking loop and the output $\Lambda_m(\tau)$ enables the tracking loops to track direct signal accurately.

The above processes: the estimate process, the correlation extractor and the cancellation method can counteract the multipath effects regarding the autocorrelation function of the received signal, since the tracking errors in DLL and PLL are not completely eliminated. Provided that the reference signal acquires the multipath error, the estimated parameters do not present accurately that of the real multipath. So as to obtain the ideal estimated parameters, the BP learning process is recursively employed. The use of multi-correlator technique can speed up BP learning process and enhance its performance.

3. Performance analysis and simulation results

In this section, computer simulations are performed to evaluate the performance of proposed method. To compare with other published methods in performance, the multipath tracking error envelopes in code and carrier phase for a multipath signal amplitude of half the LOS amplitude is denoted as $\alpha_0 = 1.0$ and $\alpha_1 = 0.5$. A GPS multipath model includes one direct signal and one delayed signal. Suppose that a high post signal to noise ratio (SNR) of 10 dB is located in this model. Simulation results are demonstrated in infinite bandwidth situation.

3.1 Simulation parameter

The digital IF frequency of a GPS signal is $\omega / 2\pi = 1.25$ MHz and the sampling rate is 5 MHz. The delay chip of the multipath signal varies from 0 to 1.5 chips with the phase of 0 and π radians with regard to the direct signal. In conventional correlator simulations, code phase error and carrier phase error are computed with 1 chip early-late discriminator. The chip spacing of a narrow correlator is less than 1 chip. A spacing of 0.2 chips utilized to serve the discriminator functions. Two different narrow correlator discriminators are adopted in a strobe correlator and the chip spacing of the two narrow correlators can be adjusted to 0.1 and 0.2 chip. The same parameters are also adopted in both enhanced strobe and edge correlators. The E1/E2 tracker of the two correlators is located at $E1 = -0.55$ and $E2 = -0.45$ with 0.1 chip spacing (Irsigler, M. et al, 2003). The Adaline-based adaptive filter method with the parameter of tap delay $d_r = 0.01$ chip, 0.1 chip, 0.5 chip and its 5 delayed tap is employed as the input to the filter. The number of multi-correlator is set as five. The initial learning rate is 0.05, the number of training samples is 5000 at 1ms C/A code period and the weights are initialized to 1. The performance is assessed on a separate test set of 100ms samples measured at intervals of 1ms samples during the adaptive process.

3.2 Performance analysis and comparison

With regard to crucial multipath mitigation techniques of internal receiver, the multipath performance of these correlation techniques will be compared with each other, including the proposed method. Thus, the envelopes of all techniques described above are plotted into the same diagram to make a comprehensive comparison of multipath mitigation performance

Figs. 10-12 compare the error envelopes of the code phase and carrier phase for all of the multipath mitigation techniques. Simulation results show that the proposed method with multipath delay at the location of set correlator as $d_r = 0.5$ chip case has both the best multipath mitigation performance. Assume the location of correlator is not at multipath delay ($d_r = 0.1$ chip), it also presents good performance. The conventional PLL has a maximum 0.52 radians in carrier phase error. Therefore, the use of the conventional correlator can yield very large maximum multipath errors and reveals the worst mitigation performance. The same results hold true for both narrow and edge correlators. Note that since the narrow, the MEDLL, the edge and strobe correlators do not provide any carrier phase elimination, their sensitivity to multipath is almost the same as the 1-chip early-late correlator. Only slight differences can be observed due to differences in their code multipath mitigation.

These figures indicates that through the use of proposed method in combination with multi-correlator technique with a delay element $d_r = 0.5$ chip, both code and carrier phase errors are reduced in the range of delay from 0 through 1.5 chip. In contrast, through the adoption of the proposed method with a tap delay $d_r = 0.5$, the code and carrier phase error decrease significantly in the range of delay from 0 to 1.5 chip. The figure shows that the use of multi-correlator technique can effectively reduce code phase error. Nevertheless, for carrier phase error, its performance remains the same. The reason is because carrier phase error is not related to multi-correlator. In the case of the tap delay $d_r = 0.5$, multipath mitigation performance degrades in comparison with the case of $d_r = 0.1$. This is because to the accuracy of the estimated delay profile in the Adaline-based filter depends on the tap delay d_r . The smaller the d_r the better the performance of multipath mitigation. In the case of the

$d_\tau=0.5$ chip, the multipath mitigation performance degrades in code phase error and the carrier phase error also exceeds that of the conventional tracking loop. Though the use of a small tap delay can yield high performance in multipath mitigation, it also takes large computation cost to estimate delay profiles. However, the use of multi-correlator can save computation cost to estimate delay profiles.

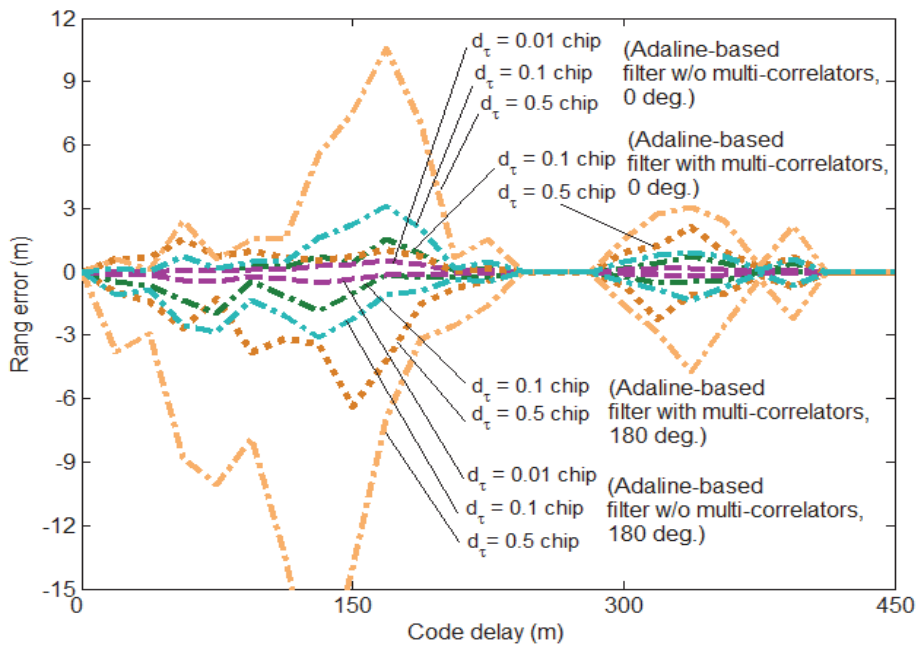

Fig. 10. Code-phase error simulation results of proposed method. ($\alpha_0 = 1.0, \alpha_1 = 0.5, \tau_0 = 0$ chip, $\tau_1 = 0 \sim 1.5$ chip, $\theta_0 = 0^\circ, (\theta_1 = 0^\circ, 180^\circ)$; delay element $d_\tau = 0.01$ chip, 0.1 chip, and 0.5 chip with and without multi-correlators.)

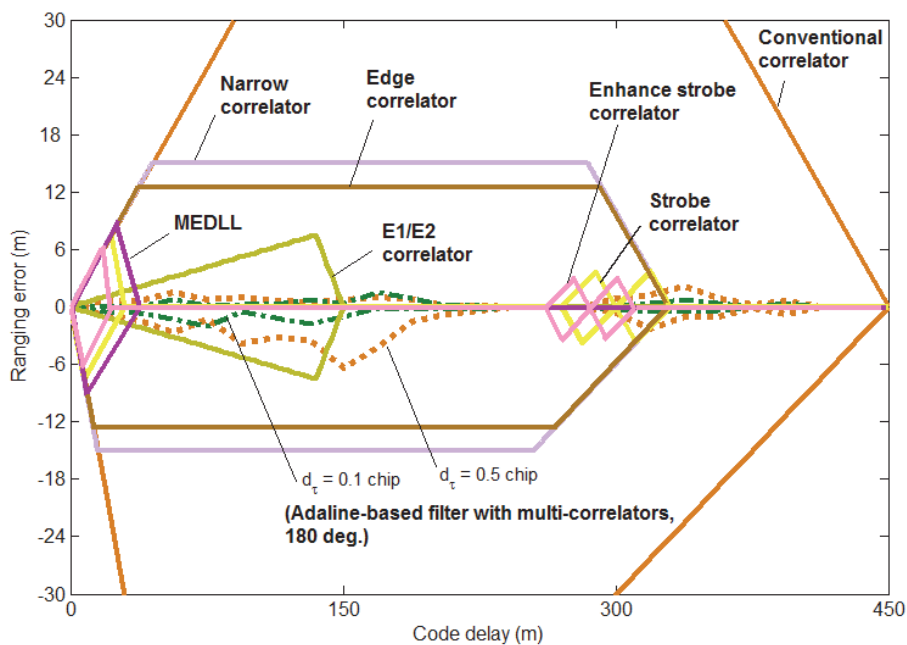

Fig. 11. Code-phase error simulation results of existing methods. ($\alpha_0 = 1.0, \alpha_1 = 0.5, \tau_0 = 0$ chip, $\tau_1 = 0 \sim 1.5$ chip, $\theta_0 = 0^\circ, (\theta_1 = 0^\circ, 180^\circ)$).

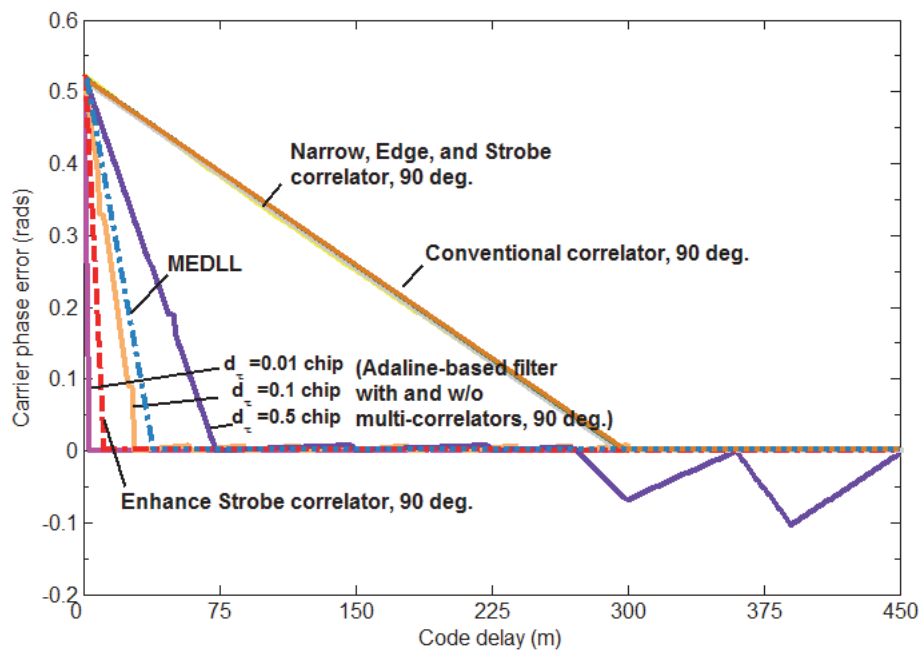

Fig. 12. Carrier phase error simulation results. ($\alpha_0 = 1.0$, $\alpha_1 = 0.5$, $\tau_0 = 0$ chip, $\tau_1 = 0 \sim 1.5$ chip, $\theta_0 = 0^\circ$, ($\theta_1 = 0^\circ, 180^\circ$)); delay element $d_\tau = 0.01$ chip, 0.1 chip, and 0.5 chip with and without multi-correlators.)

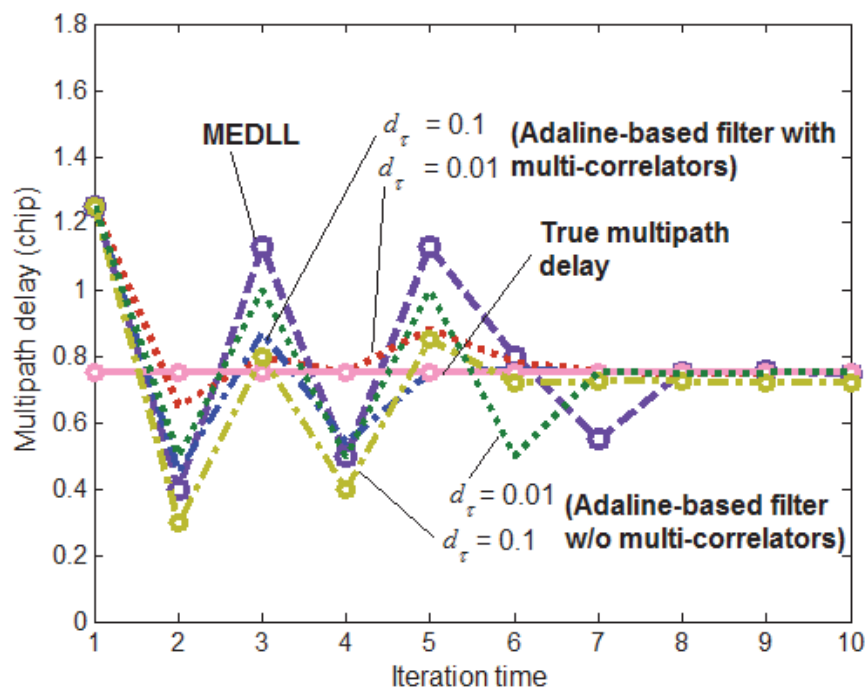

Fig. 13. Delay estimated by MEDLL and proposed method with and without multi-correlators.

Note that Fig. 11 reveals that every DLL structure lacks of performance enhancement for short delay multipath signals. Nevertheless, the proposed method with multi-correlators can perform better in short delay and medium-to-long-delay multipath environment.

Suppose a given application involves short delay and medium-to-long-delay multipath, then the best correlation techniques such as the enhanced strobe correlator will not outperform the proposed method of this paper.

To accomplish estimated performance of proposed method, the desired correct of multipath delay profiles are set $\alpha_0 = 1.0$, $\alpha_1 = 0.5$, $\tau_0 = 0$, $\tau_1 = 0.75$, $\theta_0 = 0^\circ$ and $\theta_1 = 0^\circ$. The delay element number is five and the number of multi-correlator is set as five. An estimated multipath delay versus the true multipath delay curve for three considered algorithms, the MEDLL and the Adaline-based filter with and without multiple correlators, is shown in Fig. 13. Note that the proposed method with and without multi-correlator technique of $d_r = 0.01$ has the faster convergence rate than the MEDLL. The Adaline-based filter without multi-correlator technique is rapid in convergence rate with $d_r = 0.1$. However, it suffers from a steady state error 0.03 chip in delayed estimation. Nevertheless, the use of five multi-correlators with shift 0.1 chip, the error approximates zero.

Several concessions exist in these architectures such as: noise performance, code versus carrier performance, a priori information needed as input, short delay performance and hardware/software complexity. These factors are compared in Table 1. This performance comparison is on the basis of the published methods and simulation results of this paper. The research analysis is shown in the following:

Concerning the noise mitigation performance, when SNR = -10dB, the simulation result presents that the narrow correlator and proposed method with multi-correlators are the best in performance with the code tracking error of about 0.034 chip and 0.04 chip, respectively. The proposed method without multi-correlators in this paper is medium in performance with the tracking error of around 0.05~0.1 chip, which equals the medium noise performance of the edge and E1/E2 correlator. In contrast, the conventional correlator, strobe, enhanced strobe correlator and the MEDLL are inferior in noise performance, with the tracking error around 0.2 chip.

In term of the GPS mobile applications, high precision is required even at the expense of slightly increased complexity. The best options are the enhanced strobe correlator and the Adaline-based filter. The proposed method has the best performance in multipath mitigation. Nevertheless, its hardware complexity, such as the number of required multiplications per delay estimate is on the order of $O[N_{iter}(Kd_r)^3]$ where N_{iter} is the number of filter iterations and Kd_r is an estimate of the maximum delay spread of the channel in the samples. The high complexity of this method is principally due to the matrix inversion operations. However, in short-delay and medium-to-long delay multipath environments, the number of delay samples Kd_r are smaller. Thus, the complexity of the Adaline-based filter is not very high. The enhanced strobe correlator has lower complexity, on the order of $O[(Kd_r)^2]$, but it does not perform as well as Adaline-based filter. With regard to design perspective, the best tradeoff between accuracy and complexity should be determined based on estimated maximum delay spread of the channel.

Concerning the conventional receiver design for civilian application, the lowest complexity solutions of the 1-chip E-L correlator and the narrow correlator, appear to be the best choice. What is more, complexity is the top priority and is emphasized more than performance in the design of a receiver provided that no significant degradation in performance occurs. All of the conventional, strobe and narrow correlator designs have least medium performance and reduced complexity in multipath scenarios. Hence, they are viable options for a low

complexity receiver. In comparison, even though the edge, the E1/E2 and the MEDLL designs are higher in cost, they are better than the conventional, narrow, and strobe correlators in performance.

In fact, there are inherent limitations in almost every technique. Note that the combined features of proposed method prevails over those of other techniques. In addition, the condition of short-delay and medium-to-long-delay multipath renders the effect of hardware complexity in Adaline-based filter insignificant. Consequently, the proposed method is a well-suited and well-balanced application in multipath mitigation.

	Conventional correlator	Narrow	Strobe	Enhanced strobe	Edge	E1/E2	MEDLL	Adaline-based filter	
								Without multi-correlators	With multi-correlators
Code multipath performance	×	△	△	○	△	○	○	✓	✓
Carrier multipath performance	×	×	×	△	×	×	○	△ (Count on number d_r)	✓
Short-delay multipath performance	×	×	×	△	×	○	○	✓	✓
Medium-to-long-delay multipath performance	×	×	○	○	△	✓	✓	△	✓
A priori information	Yes (Coarse delay)	Yes (Coarse delay)	Yes (Coarse delay)	Yes (Coarse delay)	Yes (Coarse delay)	Yes (Coarse delay)	Reference function	None	None
Noise Performance (SNR= - 10dB)	×	○	×	×	△	△	△	△	○
Hardware complexity	☺	☺	☺	☺	☺	☺	☹	☹ (Count on number of iteration)	☹
Software complexity	☺	☺	☺	☹	☺	☺	☺	☺	☺

✓: Best ○: Good △: Fair ×: Poor

Table 1. Comparative performance of multipath mitigation techniques.

4. Conclusion

Multipath is the primary error source in high-precision-based GNSS applications and is also a significant error source in non-differential applications. Various receiver designs have been on the market and claim various multipath mitigation functions. Most of these techniques can be characterized either as discriminator function shaping or correlation function shaping. In this

paper, an Adaline-based filter with multi-correlators method is adopted in multipath mitigation for GNSS application. A simplified direct plus multipath signal model is employed in this simulation. This approach enhances the performance of code phase and carrier phase errors compared with other published methods. Simulation results demonstrates that the proposed method is a viable and effective solution to increase the positioning accuracy for GNSS navigation in the presence of short-delay and medium-to-long-delay multipath environment.

5. Acknowledge

The author would like to thank the National Science Council of Taiwan (R.O.C.) for their support of this work under grant NSC 99-2221-E-020-036.

6. References

- Chang, C. L., & Juang, J. C. (2008). "An Adaptive Multipath Mitigation Filter for GNSS Applications," *EURASIP Journal on Advances in Signal Processing*, Vol. 2008, Article ID 214815, 10 pages
- Garin, L., van Diggelen, F., & Rousseau, J. (1996). Strobe and Edge Correlator Multipath Rejection for Code, in *Proc. ION GPS-96*, pp. 657-664, Kansas City, MO, September 17-20
- Garin, L. and Rousseau, J. (1997). Enhanced Strobe Correlator Multipath Rejection for Code and Carrier, in *Proc. ION GPS-97*, pp. 559-568, Kansas City, MO, September 16-19
- Hagerman, L. L. (1973). Effects of Multipath on Coherent and Non-coherent PRN Ranging Receiver, *Aerospace Report No. TOR-0073 (3020-03)-3*, Development Planning Division, The Aerospace Corporation
- Haykin, S. (1986) *Adaptive Filter Theory*, ISBN 013-0484-34-2, Prentice Hall, USA.
- Irsigler, M., & Eissfeller, B. (2003). Comparison of multipath mitigation techniques with consideration of future signal structures, in *Proc. ION-GPS/GNSS*, pp. 2584-2592, Portland, OR, USA, September 9-12
- Jacobs, R. A. (1988). *Increased Rates of Convergence Through Learning Rate Adaptation*, *Neural Networks*, Vol. 1, pp. 295-307
- Mattos, P. (1996). Multipath Elimination for the Low-Cost Consumer GPS, in *Proc. ION GPS-96*, pp. 665-671, Kansas City, September 1996.
- Rumelhart, D. E., Hinton, G.E., & Williams, R. J. (1986). Learning Internal Representations by Error Propagation, *Parallel Distributed Processing*, Vol. 1, MIT Press, Cambridge, MA, USA, pp. 318-362
- Schalkoff, R. J. (1997). *Artificial Neural Networks*, ISBN 007-1155-54-6, McGraw-Hill.
- Sleewaegen, J.-M., & Boon, F. (2001). Mitigating Short-delay Multipath: A Promising New Technique, pp. 204-213, in *Proc. ION GPS 2001*, Salt Lake City, UT, USA
- Stone, J., & Chansarkar, M. (2004). Anti-multipath Triangulation (AMT) for Positioning in Dense Urban Environments, in *Proc. ION GNSS*, pp. 1165-1168, Long Beach, CA, September 21-24
- van Dierendonck, J., Fenton, P., & Ford, T. (Fall 1992). Theory and Performance of Narrow Correlator Spacing in GPS Receiver, *Navigation: Journal of the Institute of Navigation*, Vol. 39, No. 3, pp.265-283

- van Dierendonck, A. J., & Braasch, M. S. (1997). Evaluation of GNSS Receiver Correlation Processing Techniques for Multipath and Noise Mitigation, in *Proc. ION-NTM*, pp. 207-215, Santa Monica, CA, USA, January 14-16
- van Nee, R. D. J. (1992). The Multipath Estimating Delay Lock Loop, in *Proc. IEEE Second Symposium on Spread Spectrum Techniques and Applications*, pp. 39-42
- van Nee, R. D. J., Siereveld, J., Fenton, P. C., & Townsend, B. R. (1994). The Multipath Estimating Delay Lock Loop: Approaching Theoretical Accuracy Limits, in *Proc. IEEE PLANS*, pp. 246-251, Las Vegas, Nev, USA, April 11-15
- Widrow, B., & Hoff, M. E. (1960) Adaptive Switch Circuits. In *IRE WESCON Convention Record*, pp. 96-104, New York, USA
- Widrow, B., & Lehr, M. A. (1990). 30 Years of Adaptive Neural Networks: Perceptron, Madaline, and BP., *Proc. IEEE*, pp. 1550-1560

IntechOpen



Adaptive Filtering Applications

Edited by Dr Lino Garcia

ISBN 978-953-307-306-4

Hard cover, 400 pages

Publisher InTech

Published online 24, June, 2011

Published in print edition June, 2011

Adaptive filtering is useful in any application where the signals or the modeled system vary over time. The configuration of the system and, in particular, the position where the adaptive processor is placed generate different areas or application fields such as: prediction, system identification and modeling, equalization, cancellation of interference, etc. which are very important in many disciplines such as control systems, communications, signal processing, acoustics, voice, sound and image, etc. The book consists of noise and echo cancellation, medical applications, communications systems and others hardly joined by their heterogeneity. Each application is a case study with rigor that shows weakness/strength of the method used, assesses its suitability and suggests new forms and areas of use. The problems are becoming increasingly complex and applications must be adapted to solve them. The adaptive filters have proven to be useful in these environments of multiple input/output, variant-time behaviors, and long and complex transfer functions effectively, but fundamentally they still have to evolve. This book is a demonstration of this and a small illustration of everything that is to come.

How to reference

In order to correctly reference this scholarly work, feel free to copy and paste the following:

Chung-Liang Chang (2011). Anti-Multipath Filter with Multiple Correlators in GNSS Receivers, Adaptive Filtering Applications, Dr Lino Garcia (Ed.), ISBN: 978-953-307-306-4, InTech, Available from: <http://www.intechopen.com/books/adaptive-filtering-applications/anti-multipath-filter-with-multiple-correlators-in-gnss-receivers>

INTECH
open science | open minds

InTech Europe

University Campus STeP Ri
Slavka Krautzeka 83/A
51000 Rijeka, Croatia
Phone: +385 (51) 770 447
Fax: +385 (51) 686 166
www.intechopen.com

InTech China

Unit 405, Office Block, Hotel Equatorial Shanghai
No.65, Yan An Road (West), Shanghai, 200040, China
中国上海市延安西路65号上海国际贵都大饭店办公楼405单元
Phone: +86-21-62489820
Fax: +86-21-62489821

© 2011 The Author(s). Licensee IntechOpen. This chapter is distributed under the terms of the [Creative Commons Attribution-NonCommercial-ShareAlike-3.0 License](#), which permits use, distribution and reproduction for non-commercial purposes, provided the original is properly cited and derivative works building on this content are distributed under the same license.

IntechOpen

IntechOpen