

We are IntechOpen, the world's leading publisher of Open Access books Built by scientists, for scientists

4,800

Open access books available

122,000

International authors and editors

135M

Downloads

Our authors are among the

154

Countries delivered to

TOP 1%

most cited scientists

12.2%

Contributors from top 500 universities



WEB OF SCIENCE™

Selection of our books indexed in the Book Citation Index
in Web of Science™ Core Collection (BKCI)

Interested in publishing with us?
Contact book.department@intechopen.com

Numbers displayed above are based on latest data collected.
For more information visit www.intechopen.com



Using Evolutionary Algorithms for Optimization of Analogue Electronic Filters

Lukáš Dolívka and Jiří Hospodka
*Czech Technical University in Prague
Czech Republic*

1. Introduction

During several recent years, the performance of computer technology increased enough to enable the using of numerical methods in various branches more commonly than in the past when mainly analytical methods were used. Numerical methods are utilized both in a design and in optimization of various systems. One of the advantages of numerical methods is the possibility of meeting more requirements – they are able to solve multi-objective (multi-criteria) tasks.

Of course, numerical methods are applied also in electronics while designing electronic circuits. Thanks to these methods, circuits can be designed with more aspect taken into account. The aspects are, naturally, primarily main circuit requirements, e.g., a magnitude frequency response, then other various features, e.g., a group delay frequency response, a dynamic range, consumption etc. However, in addition, also the parameters of used components – the tolerance and spread of their values, their real features, circuit characteristic sensitivities to their values, and so on – can be taken into consideration.

If an analytical method shall be applied to satisfy so many requirements, the circuit design would become either unfeasible or so complicated that it would be unsuccessful or inaccurate. However, numerical methods are able to operate even with a low or at least acceptable complicacy rate. On the other hand, numerical methods have disadvantages as well. One of the most significant is a higher time consumption to obtain a result compared to analytical methods. Nevertheless, this is not such a problem mostly.

2. Brief description of Evolutionary Algorithms

Evolutionary algorithms (EAs) also belong in numerical methods (Corne et al., 1999). They represent robust and powerful optimization techniques. Their theme is explored in detail today and they have been applied many times in various branches.

Other methods can be also utilized to find the extreme of a function. For instance: searching the extreme by means of the differentiations of the function, various gradient methods, simple numerical methods, or other optimization methods (Pintér, 1996), but these methods often provide not the global but a local extreme. However, the result of an optimization task should be always the most advantageous – optimal – state, which corresponds to the global extreme.

EAs are applied to finding the solution of optimization tasks. This solution has to satisfy some determined conditions. The merit of the found solution is evaluated by the value of an

objective function (OF), which is necessary for EA operation. EAs aim to optimize the OF value, i.e., aim to find its maximal or minimal value – it depends on a particular optimization task. Thus, they try to find the global extreme of the OF. The OF has a certain number of variables, denoted n here, (which is given by the task) and EAs search for its optimal value by finding suitable values of the variables. EAs proceed progressively in generations (cycles), in which a better and better OF value is achieved. Every generation is composed of a certain number of vectors, denoted N here, whose entries are the OF variables. A set in which the values of the variables of the OF, i.e., also the solution of the task, can occur (a search space) has to be defined in advance. The set can be identical to the definition scope of the OF or it can be its subset.

EAs feature several advantages compared to other methods for finding a global extreme, e.g.:

- The only property required from the OF is its value for given variable values from its definition range (which is obviously fulfilled for every function). Neither the continuity nor differentiability of the OF is required.
- If the OF has more than one global extreme, EAs are able to find them, i.e., they can provide more than one solution.
- They focus on searching for global extreme(s), not for local one(s).

However, EAs have also disadvantages:

- They need a longer time for finding the optimization task solution. This is due to their robustness.
- They utilize randomness, thus the optimization time cannot be predicted. Therefore, computing times may be different when the same optimization task is solved several times.

EAs are appropriate for solving complicated tasks. Such tasks cannot be usually solved by analytical methods. Alternatively, it would be possible but it would not be lucid, consequently, errors could arise.

Several techniques are ranked among EAs:

- genetic algorithms,
- evolutionary strategy,
- genetic programming,
- evolutionary programming,
- differential evolution,
- other algorithms.

The utilization of EAs is widespread today, both in electronics, e.g., (Dolívka & Hospodka, 2007 c; Storn, 1996 b; Vondraš & Martinek, 2002; Žiška & Vrbata, 2006) – used the differential evolution, (Haseyama et al., 1996) – used genetic algorithms, (Gielen et al., 1990) – used simulated annealing, and in other branches, e.g., (Brutovský et al., 1995; Chambers, 2000; Dasgupta & Michalewicz, 1997).

3. Optimization of analogue electronic circuits

EAs are very suitable for an optimization of analogue electronic circuits as well. This is thanks to their advantageous features mentioned above. Several aspects of optimizing analogue electronic circuits are discussed in this section.

3.1 Objective function

The general form of the OF denoted U is

$$U(x_1, x_2, \dots, x_n): X \rightarrow \mathbf{R}, \quad (1)$$

where \mathbf{R} is the set of real numbers. The set X (a search space) and all the variables x_1 to x_n of the OF are as follows

$$X = X_1 \times X_2 \times \dots \times X_n \subseteq S_1 \times S_2 \times \dots \times S_n, \quad (2)$$

$$x_i \in X_i, \quad X_i \subseteq S_i, \quad i = 1, 2, \dots, n, \quad (3)$$

where S_i is the set of real, rational, integer, natural, complex, discrete or other numbers. Thus, the OF converts an n -dimensional space into a one-dimensional set of real numbers.

If all the sets S_i are the sets of real numbers (i.e., if $S_i = \mathbf{R}$ for $i = 1$ to n) – this occurs often, (2) is changed into a simpler form

$$X \subseteq \underbrace{\mathbf{R} \times \mathbf{R} \times \dots \times \mathbf{R}}_n = \mathbf{R}^n \quad (4)$$

and all the variables x_1 to x_n are real numbers.

In case of electronic circuit optimization, the OF has a special form. The OF includes a function $O(x_0, x_1, x_2, \dots, x_n)$, whose shape shall be optimized, i.e., changed so that it satisfies requirements. The function O has the same variables x_1 to x_n as the OF. In addition to them, it has a variable x_0 , which is usually a real number. After the optimization, the values of the function O at defined values of the variable x_0 should be in defined intervals. The other variables x_1 to x_n of the optimized function O can be regarded as its parameters. The required shape of the function O is obtained by finding suitable values for them. Hence, the function O after the optimization should meet this condition

$$O(w_i, x_1, x_2, \dots, x_n) \in \langle O_D(w_i), O_H(w_i) \rangle \quad \forall w_i, \quad (5)$$

where $O(w_i, x_1, x_2, \dots, x_n)$ is the value of the function O if the variable x_0 is substituted by a value w_i . $O_D(w_i)$ and $O_H(w_i)$ are a lower and upper bound of the values of the function O if the variable x_0 is equal to w_i .

Note that, generally, both of the bounds need not be determined. For some values w_i , the condition (5) can be changed to one of these forms

$$O(w_i, x_1, x_2, \dots, x_n) \leq O_H(w_i) \quad \text{if } O_D(w_i) = -\infty, \quad (6)$$

$$O(w_i, x_1, x_2, \dots, x_n) \geq O_D(w_i) \quad \text{if } O_H(w_i) = \infty, \quad (7)$$

$$O(w_i, x_1, x_2, \dots, x_n) = O_K(w_i) \quad \text{if } O_D(w_i) = O_H(w_i) = O_K(w_i). \quad (8)$$

While using the function O , the OF is expressed by (9), d and h are the number of $O_D(w_i)$ and $O_H(w_i)$, respectively

$$U(x_1, x_2, \dots, x_n) = \sum_{i=1}^d U_{D_i}(x_1, x_2, \dots, x_n) + \sum_{i=1}^h U_{H_i}(x_1, x_2, \dots, x_n), \quad (9)$$

where the terms U_{D_i} and U_{H_i} are

$$U_{D_i}(x_1, x_2, \dots, x_n) = \begin{cases} \frac{O_D(w_i) - O(w_i, x_1, \dots, x_n)}{O_D(w_i)} & \text{if } O_D(w_i) > O(w_i, x_1, \dots, x_n), \\ 0 & \text{else,} \end{cases} \quad (10)$$

$$U_{H_i}(x_1, x_2, \dots, x_n) = \begin{cases} \frac{O(w_i, x_1, \dots, x_n) - O_H(w_i)}{O_H(w_i)} & \text{if } O_H(w_i) < O(w_i, x_1, \dots, x_n), \\ 0 & \text{else.} \end{cases} \quad (11)$$

It is obvious that if condition (5) is fulfilled, the OF has the zero value, which is its global minimum.

If the optimization shall meet more requirements, the OF can be created by the sum of more terms from (9) or terms with another form. Therefore, the OF can contain more than one function O . A penalization function can be included into the OF too. The penalization can express, e.g., a requirement for the stability of the optimized circuit.

When the OF is created by more terms, finding the global extreme of the whole OF means satisfying all the particular requirements.

In practise, the variables x_1 to x_n represent parameters the optimized circuit. The parameters can be, e.g., the values of its components or the values of zeros and poles of its transfer function. The variable x_0 is mostly frequency. The function O means an optimized circuit characteristic, e.g., a magnitude frequency response, group delay frequency response. The bounds $O_D(w_i)$ and $O_H(w_i)$ specify the intervals of the values of this characteristic. For instance, if the variable x_0 is frequency f and the function O is a magnitude frequency response $M(f)$, the bounds $O_D(w_i) = M_D(f_i)$ and $O_H(w_i) = M_H(f_i)$ determine the range in which the value of the magnitude can be at a certain frequency f_i .

3.2 Programs for optimization and analysis

A program for implementing calculations of an applied optimization algorithm is necessary for performing the optimization of a circuit.

Because mathematical operations have to be made during performing the optimization algorithm, a program capable of doing it is necessary for this purpose. Another feature that the program should have is the possibility of symbolical calculation. Suitable programs are Maple™ (Waterloo Maple) and MATLAB® (MathWorks) – one of the most widespread mathematical programs.

Moreover, it is necessary to carry out the analysis of an optimized circuit during its optimization. As a result, a program for the analysis of the optimized circuit is necessary besides the program for implementing calculations of the used optimization algorithm. This program can be, e.g.:

- PraCAN (Bičák & Hospodka, 2008): a library of functions for the Maple™ program, which facilitates a symbolic and semisymbolic analysis of continuous-working and discrete-working real linearized circuits. (PraCAN is an acronym for Prague Circuits Analyzer.)
- WinSpice (Smith): a general-purpose well-known Spice-compatible program for circuit simulation.
- Cadence (Cadence Design Systems) and Mentor Graphics (Mentor Graphics Corp.): professional programs (not only) for numerical analyzing circuits.

Of course, the most suitable program for analyzing circuits is the one that can be utilized directly in a program for implementing the optimization algorithm, otherwise, the analyzing program works as an external one, which have to be called from the mathematical program. This can lead to lower efficiency of the optimization. Thus, for the Maple™ program, the PraCAN library can be recommended. This combination of programs is used also by the authors.

3.3 Optimization methods

A powerful enough optimization method should be applied for the optimization of analogue electronic circuits. According to authors' experience, the most suitable one is the differential evolution (DE). Therefore, the authors applied this method for their optimization tasks described below.

The DE (Corne et al., 1999; Storn & Price, 1997) comes from the first half of the 90s. It is a general-purpose powerful algorithm, which has been already used in many applications. It was chosen by the authors owing to its several advantageous features (e.g., good convergence properties, ease of use, conceptual simplicity, and only a few control variables) and because it is able to achieve better results than other EAs (Storn & Price, 1996). The DE is controlled by two parameters:

- CR – a crossover constant, $CR = 0$ to 1 ,
- F – a mutation constant, $F = 0$ to 2 .

There are a few versions of the DE (Storn & Price, 1997).

A detailed description of the DE cannot be presented in this chapter because of its limited extent. For more information about the DE, refer to the mentioned references.

From the other EAs, genetic algorithms (GA) (Goldberg, 1989) are not so powerful.

When the DE is combined with another method, its efficiency is better. The most suited one is the simplex method (Nelder & Mead, 1965).

Five examples of an analogue electronic circuit optimization are shown in the next sections to better explain and document the theory of this optimization described above. In the last example, several optimization methods are compared to each other.

4. Examples of optimization of analogue continuous-working circuits

Analogue continuous-working circuits represent a big group of electronic circuits, e.g., filters, power supplies, amplifiers, oscillators, etc. Many publications about optimization of analogue continuous-working circuits have been written, e.g., (Gielen et al., 1990; Tichá & Martinek, 2005; Vondraš & Martinek, 2002; Žiška & Vrbata, 2006).

From all the mentioned kinds of analogue continuous-working circuits, filters (i.e., selective circuits) were chosen for this section. Filters can be implemented by several techniques. In this section, attention is paid to two of them, whose nonideal features are optimized by means of an EA. This section describes two optimizations:

- optimization of an LC filter – a passive filter,
- optimization of an ARC filter – an active filter.

4.1 Optimization of LC filter

4.1.1 Introduction

The utilization of LC filters in electronics started in the beginning of the previous century. However, they are utilized still owing to their several advantages, e.g.:

- low sensitivity of their transfer function to component values,
- the methods of their design are examined thoroughly,
- they can be applied in a wide frequency range – from tens Hz up to hundreds MHz.

The design of an LC filter should satisfy a determined magnitude filter specification. In some cases, also the ripple of a group delay frequency response should be considered besides the magnitude filter specification for a better circuit design. This ripple should be as low as possible. This can be done analytically but it can lead to a high filter order – a high number of circuit components. If a numerical method (e.g., an EA) is applied, the order of filter can be lower.

The components creating LC filters are inductors L and capacitors C . Hence, the nonidealities in these filters are related to the nonidealities of these components. The nonidealities of real capacitors can be neglected whereas the nonidealities of real inductors are mostly so significant that they should be taken into account. The most important nonideality of real inductors is their finite quality factor. In most cases, the effect of this nonideality on the filter transfer function has to be eliminated during the filter design. This can be accomplished either by means of prewarping the magnitude filter specification (usually causing a higher filter order) or by means of optimization.

4.1.2 Optimized circuit and its required parameters

The optimized LC filter, depicted in Fig. 1, realizes a band-pass transfer function.

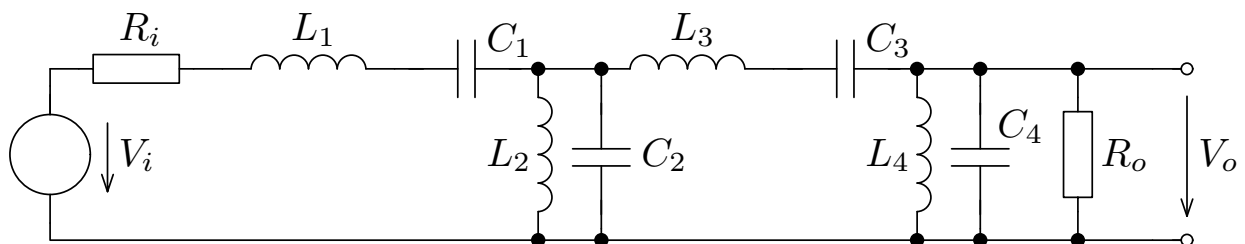

Fig. 1. Eighth-order LC band-pass filter.

The input and output resistance R_i and R_o are 1 k Ω .

The transfer function $P(f)$ of the filter is defined as the ratio of the output and input voltage

$$P(f) = \frac{V_o}{V_i}. \quad (12)$$

The magnitude frequency response $|P(f)|$ is denoted $M(f)$.

The shape of the magnitude frequency response of this filter should be according to a required magnitude filter specification in Fig. 2.

4.1.3 Description of optimization

The result of optimization should be:

- the meeting of a required magnitude filter specification – see Fig. 2,
- achieving the ripple of the group delay frequency response in the pass band not higher than 400 ns.

These requirements should be fulfilled by means of finding suitable values of the inductors and capacitors. The nonideality considered in the filter was a finite quality factor of the inductors. Its used value was 50.

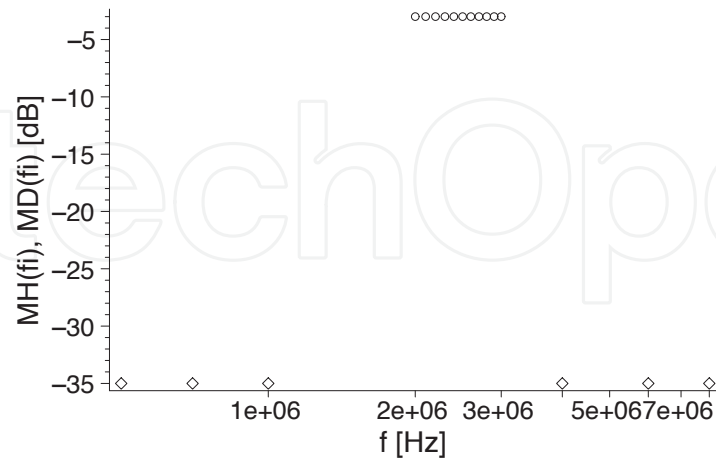

Fig. 2. Magnitude filter specification for optimization, diamonds: upper bounds $M_H(f_i)$ of magnitude ranges, circles: lower bounds $M_D(f_i)$ of magnitude ranges.

The DE was applied as the optimization algorithm in this example. The analytical solving of this example is feasible but complicated. The parameters of the optimization process were as follows:

- $CR = 0.9, F = 0.5,$
- $d = 11, h = 6,$
- $N = 80, n = 8$ (= the number of all the inductors and capacitors),
- S_1 to $S_8 = \mathbf{R},$
- X_1 to $X_4 = \langle 10^{-6}, 10^{-3} \rangle$ - the values of all the inductances can be from 1 μH to 1 mH,
- X_5 to $X_8 = \langle 10^{-12}, 10^{-9} \rangle$ - the values of all the capacitances can be from 1 pF to 1 nF.

The optimized function O is the magnitude M . It has a very long form. Therefore, it is not presented here. The meaning of the variables of the functions O is as follows:

- x_0 represents frequency f, w_i is substituted by $f_i,$
- x_1 to x_4 represent L_1 to $L_4,$
- x_5 to x_8 represent C_1 to $C_4.$

The OF was created by adding a term Z_{GD} to (9) in order to express the group delay optimization, τ_R means the value of the group delay ripple, τ_{Rmax} is the required maximal value of the group delay ripple (400 ns)

$$Z_{GD}(L_1, \dots, L_4, C_1, \dots, C_4) = \begin{cases} \frac{\tau_R(L_1, \dots, L_4, C_1, \dots, C_4) - \tau_{Rmax}}{\tau_{Rmax}} & \text{if } \tau_R(L_1, \dots, L_4, C_1, \dots, C_4) > \tau_{Rmax}, \\ 0 & \text{else.} \end{cases} \quad (13)$$

4.1.4 Result from optimization

The component values arisen from the optimization are listed in Table 1. The needed number of generations was 515. The magnitude frequency response of the circuit using these values is displayed in Fig. 3.

| i | 1 | 2 | 3 | 4 |
|------------------|--------|--------|--------|--------|
| L_i [μ H] | 282.94 | 18.823 | 191.71 | 27.524 |
| C_i [pF] | 15.177 | 241.51 | 24.542 | 164.87 |

Table 1. Component values from optimization.

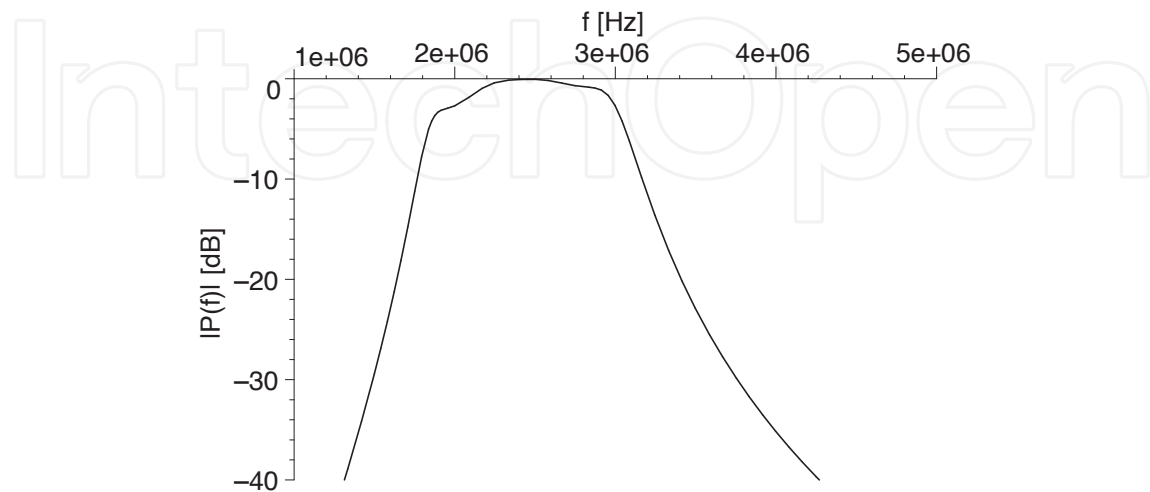

Fig. 3. Magnitude frequency response $|P(f)|$ obtained from optimization.

4.2 Optimization of ARC Filter

4.2.1 Introduction

Combining an RC network with a gain element can lead to transfer function with high Q factor complex poles (Schaumann et al., 1990). These filters are called ARC (active RC). They are used instead of LC filter to miniaturize the realization, for example, because inductors tend to be large and bulk, especially at low frequencies. ARC filters are often applied in both discrete and integrated form – both hybrid and monolithic. The active component can be realized by different elements – operational amplifiers, transconductance or transimpedance amplifiers, current conveyors, etc.

4.2.2 Optimized circuit and its required parameters

The circuit in Fig. 4 was chosen to demonstrate possibilities of optimization of ARC filters. It represents a basic band-pass filter with cascade realization by two 2nd order blocks – biquads. They use operational amplifiers as a gain element.

The nonidealities of the resistors and capacitors are not necessary to be considered whereas in case of the amplifiers, their nonidealities have to be respected.

If the amplifiers are common operational amplifiers, they have these main nonidealities:

- finite input resistance,
- nonzero output resistance,
- finite slew rate,
- finite unity-gain bandwidth,
- finite voltage gain.

The effect of input resistance is usually insignificant, especially when field-effect transistors on the operational amplifier inputs are used. The output resistance effect is usually also less important. The slew rate can be neglected when signals have low amplitude. However, the

remaining two features – unity-gain bandwidth and voltage gain – affect the transfer function of ARC filters substantially.

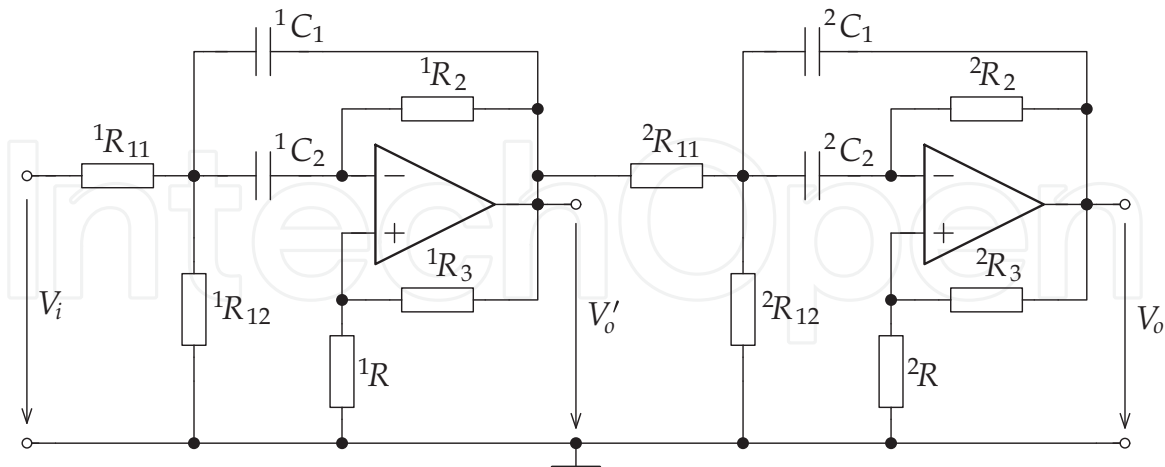

Fig. 4. Two-stage ARC band-pass filter.

Filter transfer functions are defined as follows

$$P_1 = \frac{V'_o}{V_i}, P_2 = \frac{V_o}{V'_o}. \quad (14), (15)$$

The magnitude frequency response $|P_1(f)|$ is denoted $M_1(f)$, in the same way $M_2(f)$ corresponds to $|P_2(f)|$. The symbols $P_1(f)$, $P_2(f)$, $M_1(f)$, and $M_2(f)$ are for the filter with ideal components. When nonideal components are used, these symbols are changed to $P_{1N}(f)$, $P_{2N}(f)$, $M_{1N}(f)$, and $M_{2N}(f)$.

The circuit (transfer function $P_2(f)$) should implement a band-pass filter with a magnitude filter specification presented in Fig. 7.

4.2.3 Description of optimization

During the optimization, these nonidealities were respected:

- finite unity-gain bandwidth of operational amplifiers,
- finite voltage gain of operational amplifiers.

The model in Fig. 5 was used for the operational amplifiers in the filter (Sedra & Smith, 2004). The input resistance R_{IN} and output resistance R_{OUT} were not considered (see section 4.2.1). The value of transadmittance g is 1 S and the value of voltage gain a is 1.

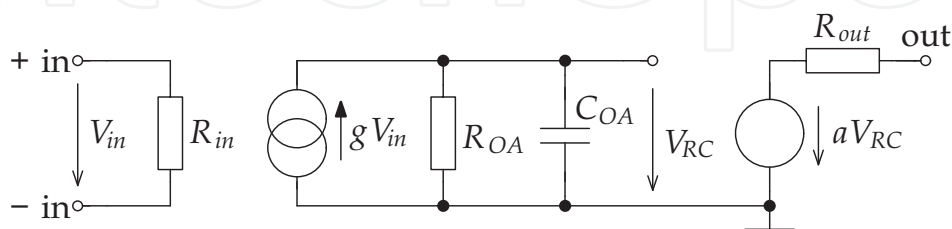

Fig. 5. Applied model of operational amplifier.

The value of the resistor R_{OA} and the capacitor C_{OA} depends on the unity-gain bandwidth B_1 and the voltage gain A_0 of the applied operational amplifier and they can be calculated according to the following formulae

$$R_{OA} = A_0, C_{OA} = \frac{\sqrt{A_0^2 - 1}}{2\pi B_1 A_0}. \quad (16), (17)$$

In Fig. 6 there is the magnitude frequency response of the filter with component values designed for ideal filter. The parameter values of the operational amplifiers were the following: $B_1 = 0.5$ MHz, $A_0 = 2 \cdot 10^5$. This figure shows the difference between magnitude frequency responses with using ideal and real components.

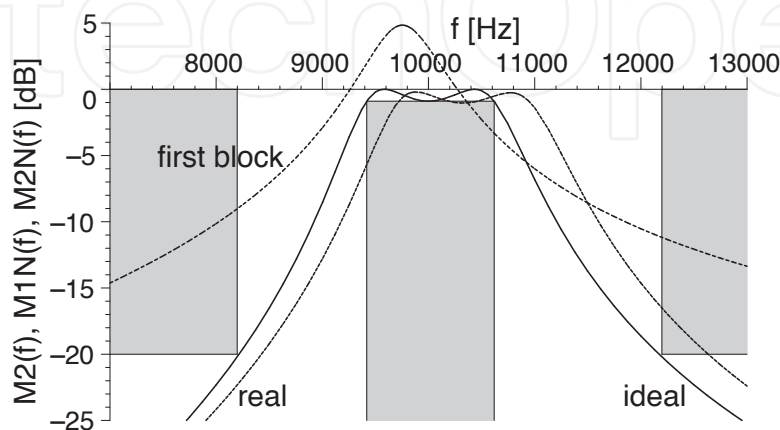

Fig. 6. Magnitude frequency responses of the ARC filter with designed component values for ideal components, solid line: magnitude M_2 , for real components, dotted line: magnitude M_{1N} and dashed line: magnitude M_{2N} .

An optimization was applied to remove the difference between the magnitude frequency responses M_2 and M_{2N} and correct dynamic conditions so that $\max |M_{1N}(f)| = \max |M_{2N}(f)|$. The result of optimization should be:

- The magnitude frequency response M_{2N} should satisfy a determined magnitude filter specification in Fig. 7.
- The magnitude frequency responses M_{1N} and M_{2N} should have their maximum values as similar as possible (because of obtaining an optimal dynamic range).

Suitable values for the resistors and capacitors in the circuit have to be found to meet the requirements.

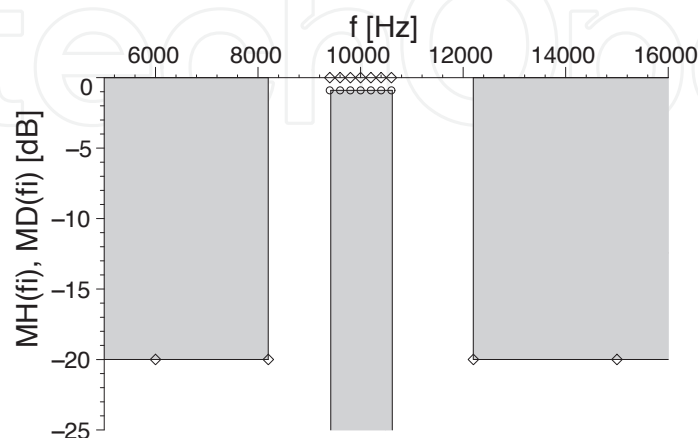

Fig. 7. Magnitude filter specification for optimization, diamonds: upper bounds $M_H(f_i)$ of magnitude ranges, circles: lower bounds $M_D(f_i)$ of magnitude ranges.

The DE was applied with the similar parameters, as in the previous example. Number of optimized components values was $n = 12$, ($N = 120$). Values of both resistors R (for both filter section) were chosen to ${}^1R = {}^2R = 10 \text{ k}\Omega$.

The OF was created by adding a term U_M to (9) in order to express the dynamic conditions optimization, where ΔM_{\max} is the permitted difference of the magnitudes maxima (10^{-6}).

$$U_M(iR_x, iC_y) = \begin{cases} |\max(M_{1N}(f)) - 1| + |\max(M_{2N}(f)) - 1| \\ \text{if } |\max(M_{1N}(f)) - 1| + |\max(M_{2N}(f)) - 1| > \Delta M_{\max}, \\ 0 \text{ else,} \end{cases} \quad (18)$$

where iR_x and iC_y represent all resistor and capacitor values of the filter form Fig. 4.

4.2.4 Result from optimization

The optimization found the component values shown in Table 2. To find them, the optimization required 4831 generations. The magnitude frequency responses corresponding to these values (and chosen values of ${}^1R = {}^2R = 10 \text{ k}\Omega$) are plotted in Fig. 8.

| Stage | R_2 [k Ω] | R_3 [k Ω] | R_{11} [k Ω] | R_{12} [Ω] | C_1 [nF] | C_2 [nF] |
|--------|---------------------|---------------------|------------------------|-----------------------|------------|------------|
| First | 11.18 | 78.47 | 38.38 | 558.5 | 7.963 | 6.370 |
| Second | 8.620 | 91.52 | 13.96 | 630.9 | 6.125 | 7.994 |

Table 2. Component values from optimization.

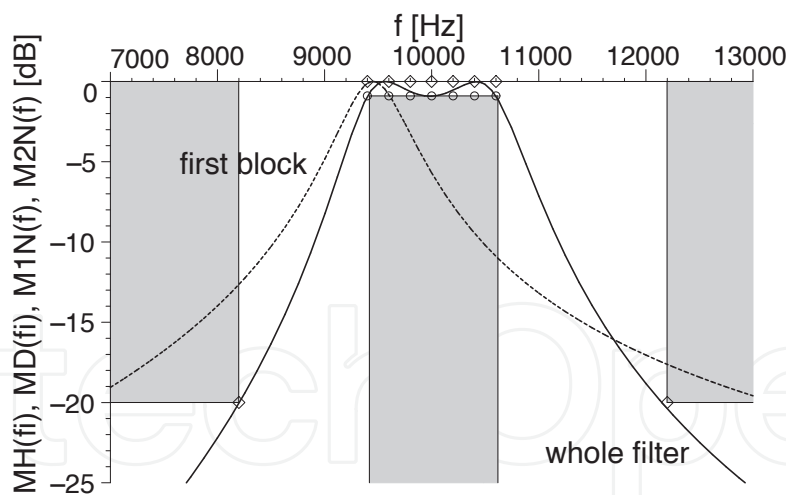

Fig. 8. Magnitude frequency responses after optimization, dotted line: magnitude M_{1N} , solid line: magnitude M_{2N} .

5. Examples of optimization of analogue discrete-working circuits

Analogue discrete-working circuits represent a group of electronic circuits utilized for circuit implementation nowadays. Two kinds of techniques belong in this group:

- switched-capacitor technique,
- switched-current technique.

However, the analysis of analogue discrete-working circuits is more complicated than in case of classical (continuous-working) circuits due to the discrete character of their operation (Bičák & Hospodka, 2003; Bičák & Hospodka, 2005). Consequently, the optimization of this kind of circuits is more difficult compared to continuously working ones (since their analysis is a necessary part of optimization).

Two optimizations are included in this section:

- optimization of a switched-capacitor filter,
- optimization of a switched-current filter.

5.1 Optimization of switched-capacitor filter

5.1.1 Introduction

One of common methods for circuit realization, integrated circuits in particular, is the switched-capacitor (SC) technique. This technique is widespread because it has a few advantages in comparison with other techniques (Ananda et al., 1995), for instance:

- The transfer of SC circuits depends not on capacitor values, but on the ratios of them. These ratios can be substantially more accurate than the capacitor values.
- A clock frequency signal f_C , which is needed for SC circuit operation, can be used for their tuning.
- SC circuits do not require resistors, whose implementation is difficult in integrated form.

As the switches in SC circuits, field effect transistors are commonly used (Ananda et al., 1995). However, this switch implementation has several nonidealities:

- nonzero off-state conductance,
- nonzero on-state resistance,
- parasitic capacitances.

From the mentioned switch nonidealities, one can say that nonzero on-state resistance R_{ON} shows itself mostly. Its effect on the transfer function of a SC circuit consists in charging a capacitor C in the circuit via this resistance. Therefore, the time constant of the charging $\tau = R_{ON}C$ is not zero as in case of an ideal switch with zero on-state resistance. The higher on-state resistance is, the higher ratio τ/T_C is and the more expressively the nonzero on-state resistance shows itself – the stronger effect of on-state resistance on the SC circuit behaviour is; T_C is the period of a clock frequency f_C , $T_C = 1/f_C$.

Another nonideality that can occur in SC circuits is the effect of the features of real operational amplifiers. These nonidealities have been discussed in section 4.2.1.

Both the nonidealities of switches and operational amplifiers affect the transfer function of SC circuits negatively.

The number of publications dealing with the optimization of SC circuits is not large, e.g., (Dolívka & Hospodka, 2006; Dolívka & Hospodka, 2007 b; Dolívka & Hospodka, 2008; Storn, 1996 a).

5.1.2 Optimized circuit and its required parameters

The SC circuit chosen for the optimization was an SC biquad (biquadratic section) with schematic diagram in Fig. 9 (Bičák & Hospodka, 2005). The symbols ϕ_1 and ϕ_2 stand for phase 1 and phase 2, respectively.

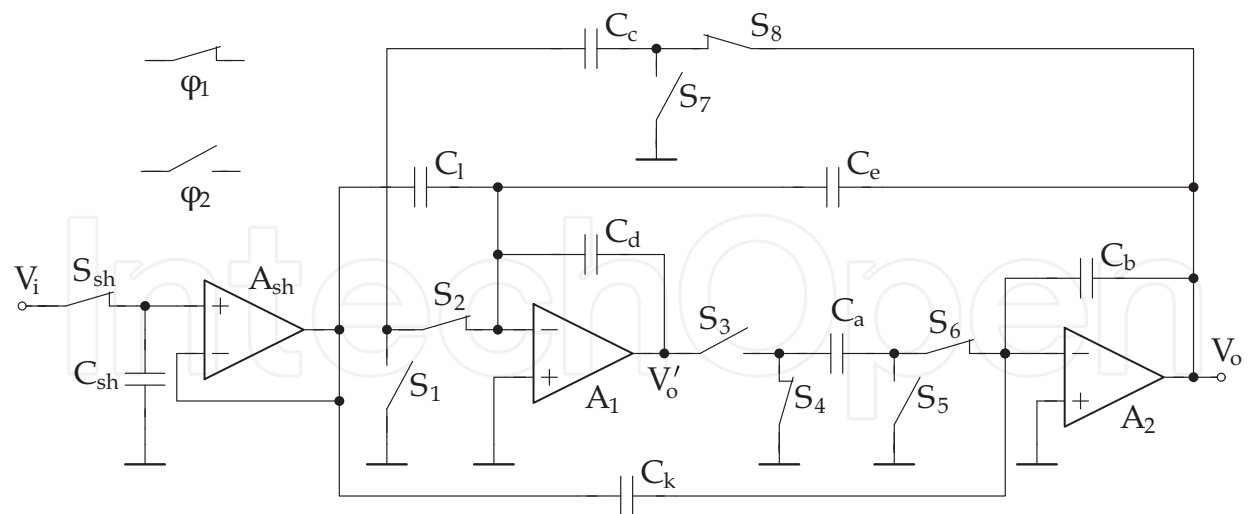

Fig. 9. Filter implemented in the switched-capacitor technique.

The transfer function from the input V_i to the output V_o' is denoted P_1 and the transfer function from the input V_i to the output V_o is denoted P_2 . This transfer function labelling is for the filter with ideal components. Hence, the following equations are valid for P_1 and P_2

$$P_1 = \frac{V_o'}{V_i}, \quad P_2 = \frac{V_o}{V_i}. \quad (19), (20)$$

The transfer functions of the filter with both ideal and nonideal components are considered from phase 1 on the input to phase 1 on the output.

The magnitude of a transfer $P(z)$ is symbolized by $M(f)$. In case of the transfers $P_1(z)$ and $P_2(z)$, the magnitudes are calculated as follows

$$M_1(f) = \left| P_1 \left(e^{j \frac{2\pi f}{f_c}} \right) \right|, \quad M_2(f) = \left| P_2 \left(e^{j \frac{2\pi f}{f_c}} \right) \right|. \quad (21), (22)$$

For the transfer functions of the filter with nonideal components, labelling P_{1N} and P_{2N} is used instead of P_1 and P_2 , respectively. The magnitudes of the transfer functions $P_{1N}(z)$ and $P_{2N}(z)$ are denoted $M_{1N}(f)$ and $M_{2N}(f)$, respectively. They are calculated from P_{1N} and P_{2N} in the same way as in case of M_1 and M_2 - according to (21) and (22).

Four kinds of filters can be implemented by this filter: low-pass, high-pass, band-pass, and notch filter. From these types, the band-pass filter was chosen. The filter was required to have these parameters:

- centre frequency: $f_0 = 400$ kHz,
- clock frequency: $f_c = 6$ MHz,
- gain at f_0 : $G_0 = 20$ dB,
- quality factor: $Q = 10$,
- transfer function implemented from the input V_i to the output V_o .

If the filter with ideal components is designed according to a common method (Ananda et al., 1995), it has magnitude frequency responses depicted in Fig. 10.

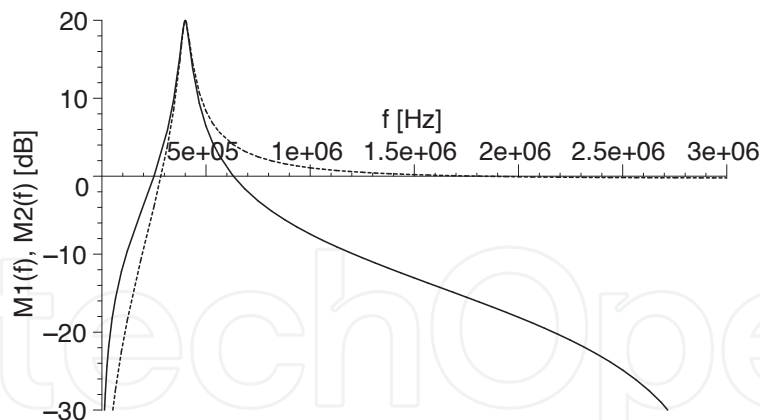

Fig. 10. Magnitude frequency responses of the SC filter with ideal components, dotted line: magnitude M_1 , solid line: magnitude M_2 .

5.1.3 Description of optimization

These nonidealities were taken into account during the optimization because their effect on SC filter characteristics is the most relevant:

- nonzero on-state resistance of the switches,
- finite unity-gain bandwidth of operational amplifiers,
- finite voltage gain of operational amplifiers.

The model in Fig. 5 was used for the operational amplifiers in the filter. Fig. 11 shows the magnitude frequency response of the filter with capacitor values designed for ideal components. The filter was analyzed with ideal and real components. The used value of switch on-state resistance was $1 \text{ k}\Omega$. The parameter values of the operational amplifiers were the following: $R_{IN} = 1 \text{ T}\Omega$, $R_{OUT} = 50 \Omega$, $B_1 = 20 \text{ MHz}$, $A_0 = 2 \cdot 10^5$. From this figure, one can see that the magnitude frequency responses are different.

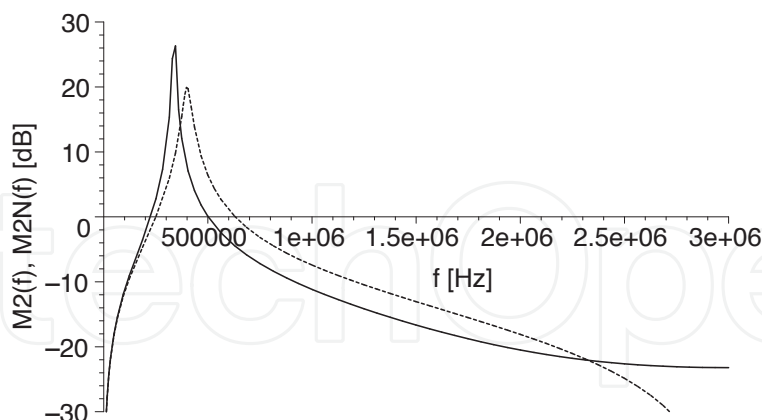

Fig. 11. Magnitude frequency responses of the SC filter with capacitor values designed for ideal components, dotted line: magnitude M_2 , solid line: magnitude M_{2N} .

The effect of the three chosen nonidealities on the magnitude frequency response of the SC circuit was eliminated using optimization. The optimization had the following aims, which shall have been satisfied by finding suitable capacitor values:

- The magnitude frequency response M_{2N} should fulfil a defined magnitude filter specification (see Fig. 12), which was derived from the magnitude frequency response M_2 .

- The magnitude frequency responses M_{1N} and M_{2N} should have their maximum values as similar as possible (because of obtaining an optimal dynamic range).
- The optimized filter should be stable in order to be applicable. (However, this aim is evident.) The condition of the stability is well known – all the poles of the transfer function in the z plane have to have the absolute value lower than 1.

The spread of capacitor values was not considered in the optimization. Nevertheless, the obtained capacitor values (see Table 3) have a spread, which is acceptable.

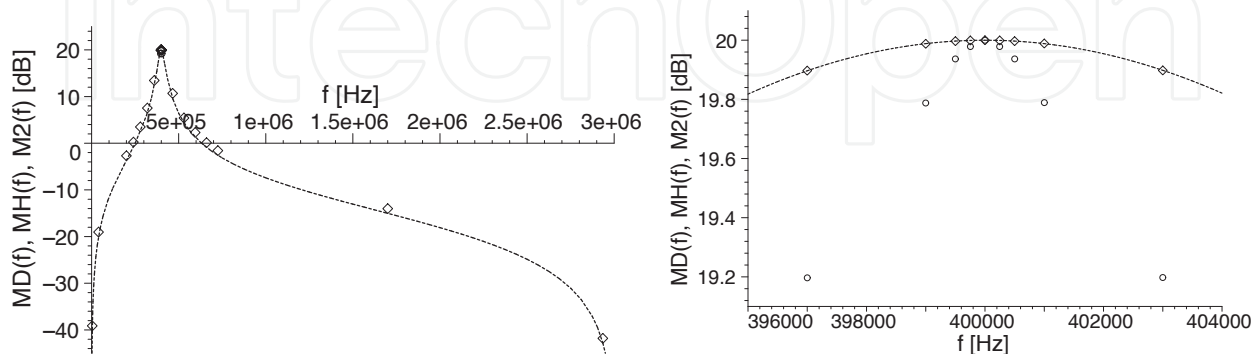

Fig. 12. Magnitude filter specification for optimization, circles: lower bounds $M_D(f_i)$ of magnitude ranges, diamonds: upper bounds $M_H(f_i)$ of magnitude ranges, dotted line: magnitude frequency response M_I . On the right: Detail for a vicinity of the frequency f_0 .

The DE was applied as the optimization algorithm in this example. Most probably, this example could not be solved analytically. The parameters of the optimization process were as follows:

- $CR = 0.9, F = 0.5,$
- $d = 9, h = 23,$
- $N = 70, n = 7$ (= the number of all the capacitors),
- S_1 to $S_7 = \mathbf{R},$
- X_1 to $X_7 = \langle 10^{-12}, 10^{-10} \rangle$ – the values of all the capacitances can be from 1 pF to 100 pF.

The optimized function O is the magnitude M_{2N} . It has a very long form. Therefore, it is not presented here. The meaning of the variables of the functions O is as follows:

- x_0 represents frequency f, w_i is substituted by $f_i,$
- x_1 to x_7 represent C_1 to $C_7.$

The form of the OF was a modification of (9) – a term for an optimization of a dynamic range was added to (9) and a penalization function expressing the requirement of the circuit stability was included into (9). The resulting OF was

$$U(C_1, \dots, C_7) = \begin{cases} \sum_{i=1}^d U_{Di}(C_1, \dots, C_7) + \sum_{i=1}^h U_{Hi}(C_1, \dots, C_7) + \left| \max M_{1N}(C_1, \dots, C_7) - M_{2N\max} \right| & \text{if the biquad is stable,} \\ 1000 & \text{if the biquad is unstable,} \end{cases} \quad (23)$$

where $\max M_{1N}$ means the maximal value of the magnitude M_{1N} and $M_{2N\max}$ means the required maximal value of the magnitude $M_{2N}, M_{2N\max} = 10$ (= 20 dB = G_0).

The optimization was performed while using the values of the real components listed above. However, the parameters R_{IN} and R_{OUT} in the model of the operational amplifiers were not

used (so $R_{IN} = \infty \Omega$ and $R_{OUT} = 0 \Omega$). The input and output resistances of the operational amplifiers were neglected because of simplifying the analysis of the filter during the optimization and thereby speeding it up. This simplification was done since their effect was supposed to be not significant. After the optimization, the analyses of the filter with the input and output resistances and without them were carried out and these analyses confirmed this assumption. The difference between these analyses can be seen in Fig. 14.

5.1.4 Result from optimization

The optimization reached the value of the OF of 0.000034 during 1523 generations. Using more generations did not improve the OF value (the total number of generations was 4000). Table 3 shows the capacitor values arisen from the optimization.

| i | a | b | c | d | e | k | l |
|------------|--------|--------|--------|--------|--------|--------|--------|
| C_i [pF] | 65.319 | 43.877 | 69.006 | 58.628 | 13.450 | 4.1664 | 52.682 |

Table 3. Capacitor values from optimization.

The magnitude frequency responses M_{1N} and M_{2N} with using the resulting capacitor values are shown in Fig. 13. The magnitude frequency response M_2 is also shown in this figure for comparing. The magnitudes M_{1N} and M_{2N} have their maxima on almost the same level; the difference between them is only about 0.00025 dB. The difference between the frequencies of the maxima occurs even in case of the magnitudes M_1 and M_2 .

The magnitudes M_{1N} and M_{2N} plotted in Fig. 13 are with $R_{IN} = \infty \Omega$ and $R_{OUT} = 0 \Omega$ - these parameters were not considered since the optimization was carried out without them (see section 5.1.3). However, their effect on the filter magnitude frequency responses is not significant. The magnitude frequency responses M_{1N} and M_{2N} with using the R_{IN} and R_{OUT} in the model of the operational amplifiers are denoted M_{1NR} and M_{2NR} , respectively.

In Fig. 14 and 15, there are the difference between the magnitude frequency responses M_{1NR} and M_{1N} and the difference between M_{2NR} and M_{2N} . It is apparent from the figure that the differences are not high. Higher values (but not too high) are only in the stop-band of the difference between M_{2NR} and M_{2N} .

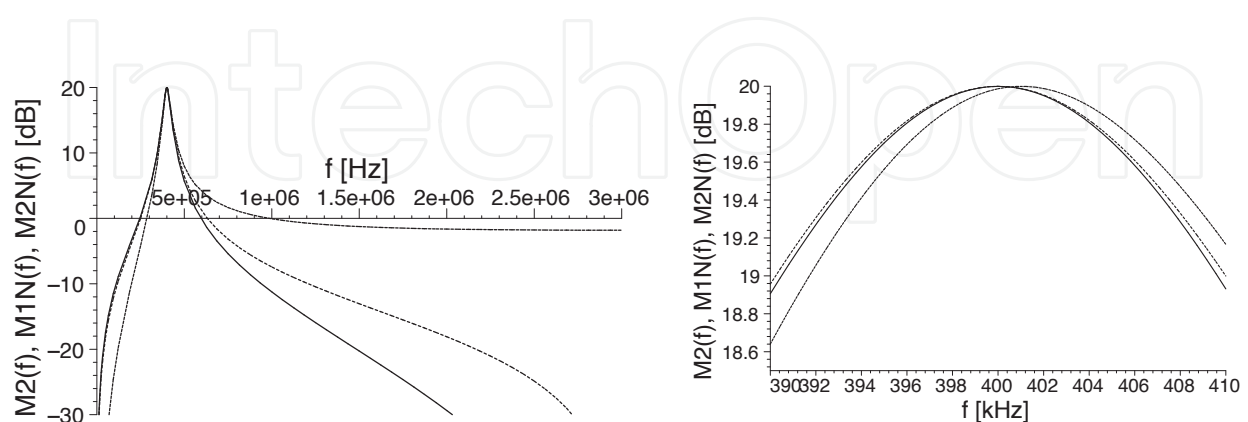

Fig. 13. Magnitude frequency responses of the SC filter, dotted line: magnitude M_2 , dashed line: magnitude M_{1N} after optimization, solid line: magnitude M_{2N} after optimization. On the right: Detail for a vicinity of the frequency f_0 .

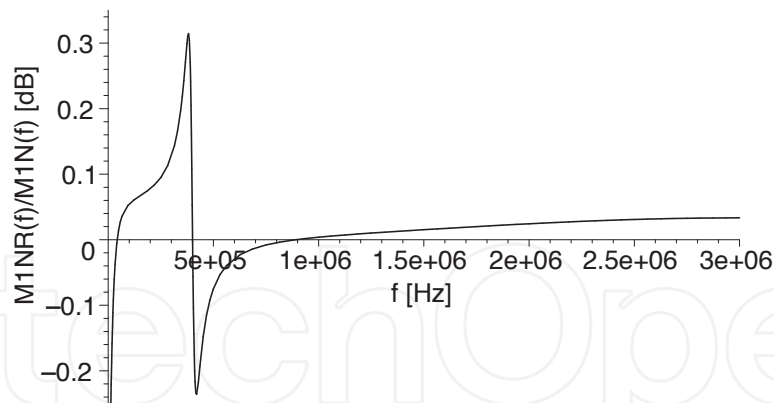

Fig. 14. Difference between magnitude frequency responses M_{1NR} and M_{1N} .

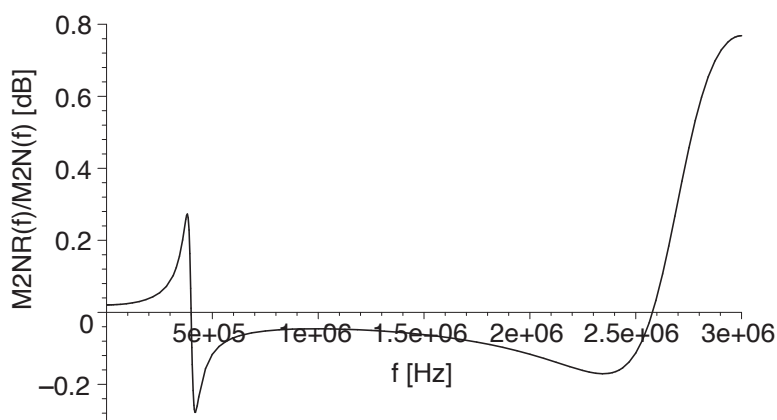

Fig. 15. Difference between magnitude frequency responses M_{2NR} and M_{2N} .

Of course, the optimization could be accomplished including the parameters R_{IN} and R_{OUT} but it would take a longer time than without them (about three times).

5.2 Optimization of switched-current filter

5.2.1 Introduction

The switched-current (SI) technique is applied commonly for the implementation of functional blocks because it has a few advantages (Toumazou et al., 1993):

- Suitable for the integrated form of circuits with utilizing VLSI-CMOS technology, i.e., possible integration of SI circuits with digital ones.
- Operation in the current mode – a high dynamic and frequency range.
- The transfer function of SI circuits depends on the ratios of the transconductances g_m of the transistors in individual circuit stages, not on the transconductance itself. The ratios can be substantially more accurate than the transconductances.
- No need of floating capacitors, required grounded ones only.
- Capacitor values do not affect the transfer function.

The nonidealities that can occur in SI circuits are especially related to the used switches and transistors. The transistors in SI circuits operate as controlled current sources. Their main nonideal features are finite output resistance and parasitic capacitances. In case of the switches, the nonideal features are these: nonzero on-state resistance, finite off-state resistance, and parasitic capacitances. These nonidealities are caused by the implementation of the switches by field-effect transistors.

Other properties of circuits realized by the SI technique that can be optimized to achieve a better circuit design are the sum of all transconductance values and the ratio between the highest and lowest transconductance value. These parameters should be as small as possible. Minimizing the sum of all transconductance values is owing to a small area of the chip with the SI circuit. Transconductance g_m of a transistor is linearly dependent on the ratio W/L , where W is the width of the transistor channel on the chip and L is its length. The minimal value of the length is limited by the used technology for circuit implementing. The transistor area on the chip is dependent on $W \cdot L$. Thus, for a given length, the smaller transconductance (smaller width) is, the smaller area is occupied by the transistor. Moreover, a smaller width causes smaller parasitic capacitances. The ratio between the highest and lowest transconductance value – the spread of transconductance values – should be minimized because its lower value is more suitable for circuit design.

The optimization of SI circuits is described in few publications. Authors know only about (Erten et al., 1999), which describes the optimization of SI circuits by means of simulated annealing. Authors' publications about the optimization of SI circuits are (Dolívka & Hospodka, 2007 a; Dolívka & Hospodka, 2007 c; Dolívka & Hospodka, 2008).

5.2.2 Optimized circuit and its required parameters

The SI circuit used in this section was a filter working as a biquad (biquadratic section), whose schematic diagram is in Fig. 16 (Toumazou et al., 1993). The symbols ϕ_1 and ϕ_2 stand for phase 1 and phase 2, respectively. Every transistor T_i has transconductance g_{mi} and the ratio of the currents of any two current sources in the upper part of Fig. 16 is the same as the ratio of the transconductances of the transistors connected to these current sources. Only one of the current values $a_i I$ has to be chosen so that the transistors are in the linear part of their output characteristic.

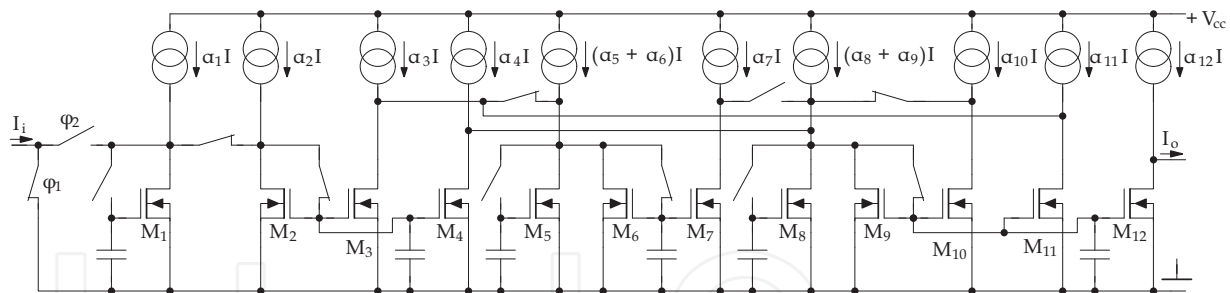

Fig. 16. Filter implemented in the switched-current technique.

The transfer function of the filter from the input I_i to the output I_o with using ideal components is denoted as P_I . All the filter transfer functions (with both ideal and nonideal components) in this section are considered from phase 2 on the input to phase 2 on the output. The transfer function P_I can be express according to (24) and the magnitude $M_I(f)$ of the transfer function $P_I(z)$ according to (25).

$$P_I = \frac{I_o}{I_i}, \quad M_I(f) = \left| P_I \left(e^{j \frac{2\pi f}{f_c}} \right) \right|. \quad (24), (25)$$

The transfer function of the filter using the nonideal components is symbolized P_N . The magnitude of this transfer is symbolized $M_N(f)$ and is related to the transfer $P_N(z)$ in the same manner to M_I – in accordance with (25).

This filter can realize a few filter types. A low-pass filter was chosen here. Its transfer function should have these parameters:

- pass-band cut-off frequency: $f_P = 1$ MHz,
- clock frequency: $f_C = 10$ MHz,
- quality factor: $Q = 0.707$,
- gain at 0 Hz: $G_0 = 20$ dB.

5.2.3 Description of optimization

Two nonidealities from those listed above were chosen for this optimization:

- finite output resistance of the transistors working as current sources,
- nonzero on-state resistance of the switches.

These nonideal features can be considered as the most important for these components.

To express the output resistance R_{OUT} of the transistors in the SI filter, the equivalent circuit in Fig. 17 (Sedra & Smith, 2004) was used for them. The output resistance R_{OUT} of the transistors is connected in parallel to the output resistance of the current sources in the upper part of Fig. 16 for alternating input current I_i . The value that was considered for this resulting resistance was 20 k Ω .

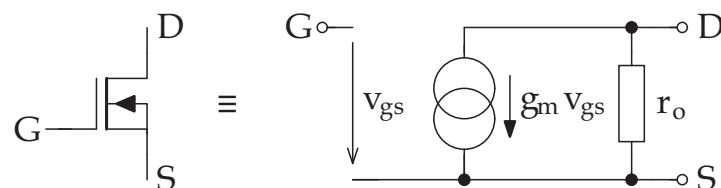

Fig. 17. Used equivalent circuit for transistors.

The nonzero on-state resistance of the switches was represented by a resistor connected in series to the ideal switch. The chosen value for the resistance was 1 k Ω .

Fig. 18 shows the magnitude frequency responses for the SI filter with transconductance values designed for ideal components. It is obvious from this figure that the difference between the magnitudes M_I and M_N is not small. Thus, the nonidealities affect the transfer function of the filter markedly.

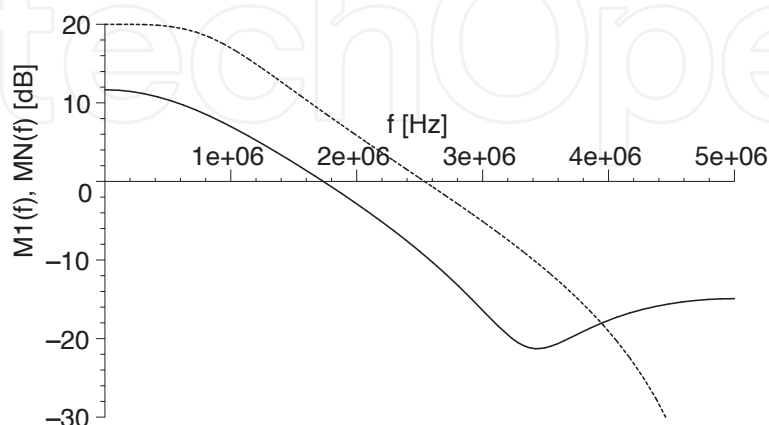

Fig. 18. Magnitude frequency responses of the SI filter with transconductance values designed for ideal components, dotted line: magnitude M_I , solid line: magnitude M_N .

To remove the undesirable effect of the nonidealities on the filter transfer function, new values of transconductances had to be found. This was made by optimization. In addition to this requirement, the optimization result had to meet two more aims. Hence, all the three requirements for this multi-objective (multi-criteria) optimization result were these:

- removing the undesirable effect of the nonidealities on the filter transfer function, i.e., achieving the shape of the magnitude frequency response M_N of the SI filter with the nonideal components as similar as possible to the magnitude frequency response M_I of the ideal filter,
- achieving the sum of all transconductance values as small as possible,
- achieving the ratio between the highest and lowest transconductance value as small as possible.

These requirements shall have been met by finding suitable transconductance values.

Because of the first aim of the optimization, a magnitude filter specification was defined – see Fig. 19.

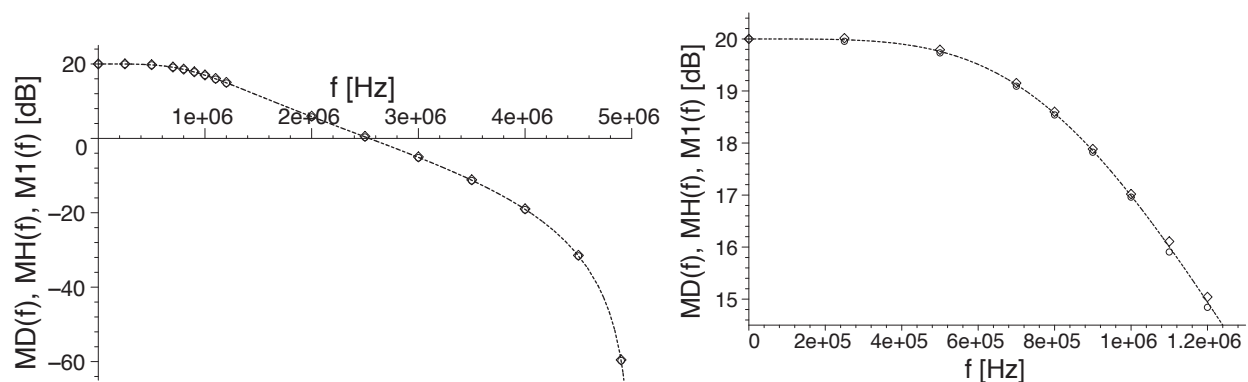

Fig. 19. Magnitude filter specification for optimization, circles: lower bounds $M_D(f_i)$ of magnitude ranges, diamonds: upper bounds $M_H(f_i)$ of magnitude ranges, dotted line: magnitude frequency response M_I . On the right: Detail for a frequency range of 0 to 1.3 MHz.

The DE was applied as the optimization algorithm in this example. Most probably, there is not any analytical method capable of accomplishing this optimization task. The parameters of the optimization process were as follows:

- $CR = 0.9, F = 0.5,$
 - $d = 16, h = 16,$
 - $N = 120, n = 12$ (= the number of all the transistor transconductances),
 - S_1 to $S_{12} = \mathbf{R},$
 - X_1 to $X_{12} = \langle 10^{-5}, 10^{-2} \rangle$ – the values of all the transconductances can be from 10 μS to 10 mS.
- The optimized function O is the magnitude M_N . It has a very long form. Therefore, it is not presented here. The meaning of the variables of the functions O is as follows:
- x_0 represents frequency f, w_i is substituted by $f_i,$
 - x_1 to x_{12} represent g_{m1} to $g_{m12}.$

To meet the second and third aim of the optimization, two terms were added to (9). This form of the OF was applied

$$\begin{aligned}
 U(g_{m1}, g_{m2}, \dots, g_{m12}) = & b_M \left(\underbrace{\sum_{i=1}^d U_{Di}(g_{m1}, g_{m2}, \dots, g_{m12}) + \sum_{i=1}^h U_{Hi}(g_{m1}, g_{m2}, \dots, g_{m12})}_{U_M} \right) + \\
 & + b_S \underbrace{\sum_{i=1}^n g_{mi}}_{U_S} + b_R \frac{\max_{i \in \{1, 2, \dots, n\}}(g_{mi})}{\min_{i \in \{1, 2, \dots, n\}}(g_{mi})}, \quad (26)
 \end{aligned}$$

with this symbol meaning:

$\max_{i \in \{1, 2, \dots, n\}}(g_{mi})$ the maximal value from all transconductance values,

$\min_{i \in \{1, 2, \dots, n\}}(g_{mi})$ the minimal value from all transconductance values,

b_M the weight of the optimization of the magnitude frequency response,

U_M the rate of satisfying the magnitude filter specification by the optimized magnitude frequency response,

b_S the weight of the optimization of the sum of all transconductance values,

U_S the sum of all transconductance values,

b_R the weight of the optimization of the ratio between the highest and lowest transconductance value,

U_R the ratio between the highest and lowest transconductance value.

It is obvious from (26) that the value of the OF U is always higher than 0. Whereas the OF term U_M can be zero (which expresses that the optimized magnitude frequency response meets the magnitude filter specification), the term U_S is always higher than 0 and the term U_R is always higher than 1.

The values of the weights b_M , b_S , and b_R are presented in the following section.

5.2.4 Result from optimization

For a satisfactory optimization result, proper setting of the weights in the OF (26) is necessary. Table 4 presents various values of the weights and corresponding results of the optimization. One of the weights can be always equal to 1 because only the ratios between the weights are important for the optimization.

| b_M | b_S | b_R | U_{1G} | U_M | U_S | U_R | U | ΔU_{3000G} |
|-------|-------|-------|----------|---------|--------|-------|------|----------------------|
| 1 | 1 | 1 | 24.9 | 0.00668 | 0.0857 | 3.42 | 3.51 | $4.28 \cdot 10^{-5}$ |
| 1 | 10 | 1 | 25.4 | 0.00376 | 0.0715 | 3.48 | 4.19 | $6.62 \cdot 10^{-5}$ |
| 1 | 10 | 3 | 46.0 | 1.64 | 0.0795 | 2.76 | 10.7 | $1.60 \cdot 10^{-3}$ |
| 1 | 30 | 1 | 26.7 | 0.349 | 0.0510 | 3.57 | 5.45 | $2.11 \cdot 10^{-4}$ |
| 4 | 100 | 1 | 74.6 | 0.0960 | 0.0477 | 4.17 | 9.32 | $6.04 \cdot 10^{-1}$ |
| 2 | 30 | 1 | 41.2 | 0.0194 | 0.0697 | 3.49 | 5.62 | $1.02 \cdot 10^{-3}$ |

Table 4. The results of the optimization with various values of the weights b_M , b_S , and b_R in the OF, U_{1G} : the value of the OF after the 1st generation, U_M , U_S , U_R , U : values after 4000 generations, ΔU_{3000G} : the improvement (i.e., lowering) of the OF value in the last 3000 generations, i.e., since the 1000th generation.

The last column in Table 4 shows that using more than 1000 generations in this optimization yields only a low improvement of the OF value.

From the values of the weights in Table 4, the most suitable ones are those on the last line because then the values of U_M , U_S , and U_R are optimized equally, so they are regarded as the optimization result here. However, of course it is possible to use another combination of the weight values from Table 4 to get a utilizable optimization result.

Table 5 shows the transconductance values arisen from the optimization with the weight values on the last line of Table 4, i.e., $b_M = 2$, $b_S = 30$, and $b_R = 1$.

| i | 1 | 2 | 3 | 4 | 5 | 6 |
|---------------|--------|--------|--------|--------|--------|--------|
| g_{mi} [mS] | 2.4417 | 2.4417 | 8.5222 | 2.4417 | 8.5222 | 6.3116 |

| i | 7 | 8 | 9 | 10 | 11 | 12 |
|---------------|--------|--------|--------|--------|--------|--------|
| g_{mi} [mS] | 8.5222 | 8.5222 | 4.8032 | 6.2199 | 2.4417 | 8.5222 |

Table 5. Transconductance values from optimization.

Because the value of U_M is not zero, the optimized magnitude frequency response does not quite fulfil the magnitude filter specification. The violations of the magnitude filter specification occur only at the following three frequencies:

- 0 Hz: required value: 20 dB, obtained value: 19.9999999995 dB,
- 4.5 MHz: required values: -31.640 to -31.440 dB, obtained value: -31.6400000007 dB,
- 4.9 MHz: required values: -59.737 to -59.537 dB, obtained value: -59.3704 dB.

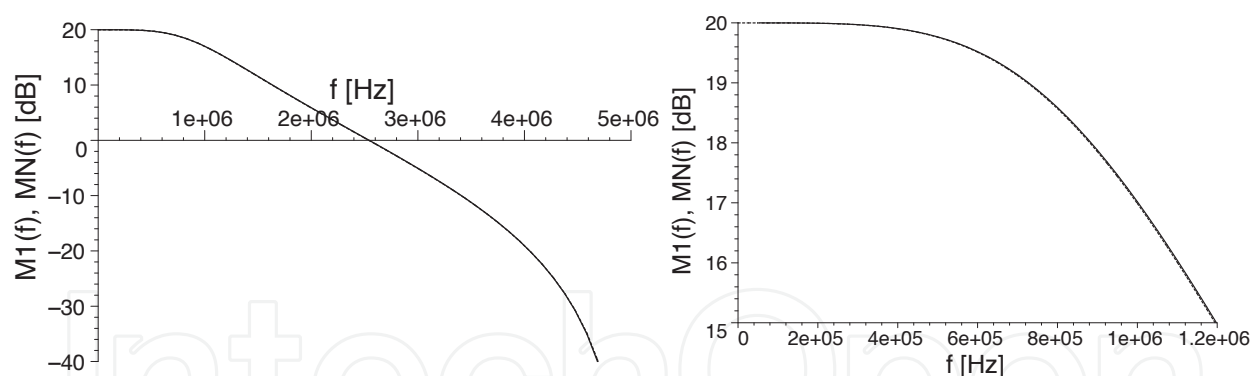

Fig. 20. Magnitude frequency responses of the SI filter, dotted line: magnitude M_I , solid line: magnitude M_N after optimization. On the right: Detail for a frequency range of 0 to 1.2 MHz.

It is apparent that these violations are slight.

In Fig. 20, there is the magnitude frequency response M_N with using the resulting transconductance values. The magnitude frequency response M_I is also shown in this figure for comparing. It is evident from the figure that the difference between the magnitudes M_N and M_I is very little.

If the terms U_S and U_R were not considered in the optimization (i.e., if the value of the weights b_S and b_R were 0), the obtained sum of all transconductance values would be 0.0737 and the ratio between the highest and lowest transconductance value would be 4.11. Hence,

both of them would be worse than in case of this optimization. Therefore, it is obvious that considering these two requirements in optimization leads to a better circuit design.

6. Comparing several optimization methods

This section shows the suitability of ten optimization methods for optimization of analogue electronic filters. The methods are compared as for their speed of optimization and ability to search for the global extreme, not a local one. The chosen methods are:

- a. DE, version best/1/bin
- b. DE, version best/1/bin combined with the simplex method
- c. DE, version EDE
- d. DE, version EDE combined with the simplex method
- e. DE, version rand/1/bin
- f. DE, version rand/1/bin combined with the simplex method
- g. DE, version rand-to-best/1/bin
- h. DE, version rand-to-best/1/bin combined with the simplex method
- i. GA
- j. GA combined with the simplex method

The version EDE of the DE differs from other versions of the DE in the way of generating a trial vector (Vondraš & Martinek, 2002).

The optimization task utilized for this comparing was similar to the one presented in section 5.1, so it is a common optimization of an analogue electronic filter.

The value of the applied OF is 0 if the optimization is successful. The optimization methods were required to achieve the OF value lower or equal to 10^{-10} . To get this result, the methods needed numbers of generations G_N , which are listed in Table 6, where the OF value U_{OBT} obtained by them is presented too.

| Method | Without the simplex method | | With the simplex method | |
|------------------------|----------------------------|----------------------|-------------------------|----------------------|
| | G_N | U_{OBT} | G_N | U_{OBT} |
| DE, best/1/bin | 94 | $8.6 \cdot 10^{-11}$ | 60 | $2.3 \cdot 10^{-11}$ |
| DE, EDE | 173 | $4.4 \cdot 10^{-11}$ | 61 | $6.1 \cdot 10^{-11}$ |
| DE, rand/1/bin | >2000 | $1.4 \cdot 10^{-9}$ | 114 | $4.0 \cdot 10^{-11}$ |
| DE, rand-to-best/1/bin | 179 | $9.1 \cdot 10^{-11}$ | 72 | $4.1 \cdot 10^{-11}$ |
| GA | >2000 | $3.9 \cdot 10^{-2}$ | >2000 | $7.3 \cdot 10^{-10}$ |

Table 6. Results obtained by means of the chosen methods.

Fig. 21 illustrates the achieved value of the OF versus the number of generations. The speed of optimization of all the methods can be seen easily from it. Fig. 21 together with Table 6 shows the ability to search for the global extreme too. The method i could not find the global extreme but a local one only whereas the other methods except for e converged to the global extreme quickly. The method b turned out to be the best one.

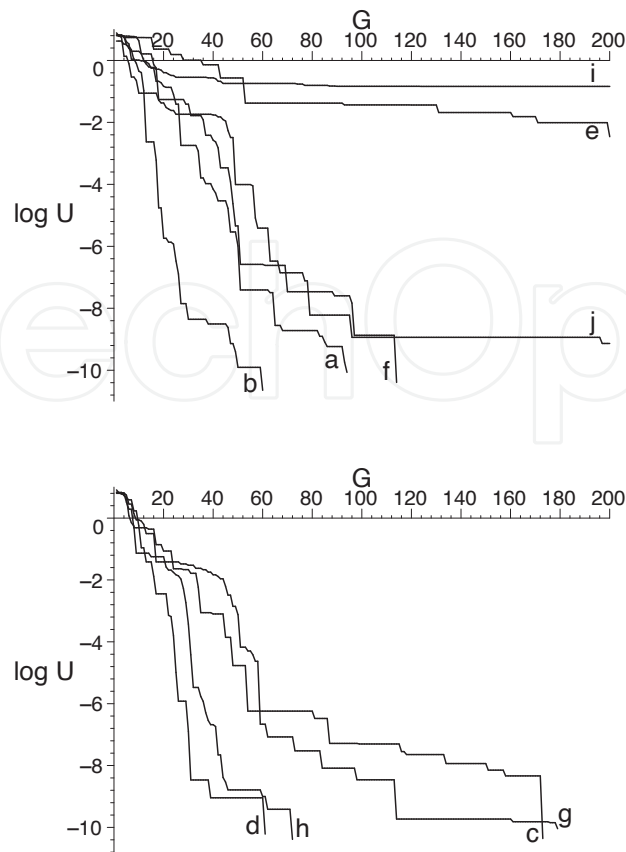

Fig. 21. Dependence of the value of the OF on the number of generations during optimization process performed by means of the chosen methods.

7. Conclusion

The aim of this chapter was to show possibilities of an optimization of analogue electronic filters by means of evolutionary algorithms. In practise, there are many cases when common analytical methods cannot be used for obtaining required circuit characteristics and/or eliminating nonideal circuit features. Evolutionary algorithms are very suitable for this purpose.

The ways to carry out the optimization of analogue electronic filters were described in the beginning of this chapter. Then a few examples of optimizations were presented to explain the description better. The optimized circuits were chosen from both analogue continuous-working ones and analogue discrete-working ones. Several evolutionary algorithms were compared regarding their efficiency while optimizing analogue electronic filters at the end of the chapter.

8. References

- Ananda P. V. M.; Ramachandran V. & Swamy M. N. S. (1995). *Switched Capacitor Filters – Theory, Analysis and Design*, Prentice Hall International, ISBN 0-13-879818-4
- Bičák J. & Hospodka J. (2003). Frequency response of switched circuits in SPICE, *Proceedings of conference ECCTD 2003*, pp. I/333–I/336, IEEE, ISBN 83-88309-95-1

- Bičák J. & Hospodka J. (2005). PraSCAN – Maple package for analysis of real periodically switched circuits, *Proceedings of Maple Conference 2005*, pp. 8–18, Maplesoft, a division of Waterloo Maple Inc., Waterloo Ontario, ISBN 1-894511-85-9
- Bičák J. & Hospodka J. (2008). PraCAN – Maple package for symbolic circuit analysis, *Proceedings of conference Digital Technologies*, EDIS Žilina University Publisher, Žilina, ISBN 978-80-8070-953-2
- Brutovský B.; Ulicný J. & Miškovský P. (1995). Application of genetic algorithms based techniques in the theoretical analysis of molecular vibrations, *Proceedings of conference Mendel'95*, pp. 29–33, Brno, ISBN 80-214-0672-0
- Cadence Design Systems, Inc.: <http://www.cadence.com>
- Chambers L. D. (2000). *The Practical Handbook of Genetic Algorithms, Applications*, Chapman & Hall/CRC, ISBN 1-58488-240-9
- Corne D.; Dorigo M. & Glover F. (editors). (1999). *New Ideas in Optimization*, McGraw-Hill, London, ISBN 0-07-709506-5
- Dasgupta D. & Michalewicz Z. (1997). *Evolutionary Algorithms in Engineering Applications*, Springer-Verlag, Berlin, ISBN 3-540-62021-4
- Dolívka L. & Hospodka J. (2006). Elimination of switch on-state resistance effect on a switched-capacitor filter characteristic, *Proceedings of conference PRIME 2006*, pp. 177–180, IEEE, ISBN 1-4244-0156-9
- Dolívka L. & Hospodka J. (2007 a). Switched-current filter optimization based on evolutionary algorithms, *Proceedings of conference ECCTD 2007*, pp. 551–554, IEEE, ISBN 1-4244-1342-7
- Dolívka L. & Hospodka J. (2007 b). Switched-capacitor filter optimization with respect to switch on-state resistance and features of real operational amplifiers, *Radioengineering*, vol. 16, no. 2, pp. 34 – 39, Brno, ISSN 1210-2512
- Dolívka L. & Hospodka J. (2007 c). Using the differential evolution algorithm for the multi-objective optimization of a switched-current circuit, *Proceedings of conference CEC 2007*, pp. 1351–1358, IEEE, ISBN 1-4244-1340-0
- Dolívka L. & Hospodka J. (2008). Ways to optimize analogue switched circuits, *Radioengineering*, vol. 17, no. 4, pp. 48–54, Brno, ISSN 1210-2512
- Erten I. G.; Dundar G. & Balkir S. (1999). Optimization and synthesis of switched current filters with nonideal MOS transistors, *Proceedings of Third International Workshop on Design of Mixed-Mode Integrated Circuits and Applications 1999*, pp. 13–17, ISBN 0-7803-5588-1
- Gielen G. G. E.; Walscharts H. C. C. & Sansen W. M. C. (1990). Analog circuit design optimization based on symbolic simulation and simulated annealing, *IEEE Journal of Solid-State Circuits*, vol. 25, no. 3, pp. 707–713, IEEE, ISSN 0018-9200
- Goldberg D. E. (1989). *Genetic Algorithms in Search, Optimization and Machine Learning*, Addison-Wesley Publishing Co., Reading, Massachusetts, ISBN 0-201-15767-5
- Haseyama M.; Aketa Y. & Kitajima H. (1996). A method quantizing filter coefficients with genetic algorithm and simulated annealing, *IEICE Transactions on Fundamentals of Electronics, Communications and Computer Sciences*, vol. E79-A, no. 8, pp. 1130–1134, ISSN 0916-8508
- MathWorks, Inc.: <http://www.mathworks.com>

- Mentor Graphics Corp.: <http://www.mentor.com>
- Nelder J. A. & Mead R. (1965). A simplex method for function minimization, *Computer Journal*, vol. 7, no. 4, pp. 308–313
- Pintér J. D. (1996). *Global Optimization in Action*, Kluwer Academic Publishers, ISBN 0-7923-3757-3
- Sedra A. S. & Smith K. C. (2004). *Microelectronic Circuits*, 5th edition, Oxford University Press, ISBN 0-19-514251-9
- Schaumann R.; Ghausi M. S. & Laker, K. R. (1990). *Design of Analog filters*, Prentice-Hall, New Jersey 1990, ISBN 0-13-200288-4.
- Smith M. *WinSpice User's Manual*. <http://www.winspice.com>
- Storn R. (1996 a). System design by constraint adaptation and differential evolution, *Technical report TR-96-039*, ICSI
- Storn R. (1996 b). Differential evolution design of an IIR-filter, *Proceedings of conference ICEC'96*, pp. 268–273, IEEE, ISBN 0-7803-2902-3
- Storn R. & Price K. (1996). Minimizing the real functions of the ICEC'96 contest by differential evolution, *Proceedings of conference ICEC'96*, pp. 842–844, IEEE, ISBN 0-7803-2902-3
- Storn R. & Price K. (1997). Differential evolution – a simple and efficient heuristic for global optimization over continuous spaces, *Journal of Global Optimization*, vol. 11, no. 4, pp. 341–359, Kluwer Academic Publishers, ISSN 0925-5001
- Tichá D. & Martinek P. (2005). OTA-C lowpass design using evolutionary algorithms, *Proceedings of conference ECCTD 2005*, vol. 2, pp. 197–200, University College Cork, ISBN 0-7803-9066-0
- Toumazou C.; Hughes J. B. & Battersby N. C. (1993). *Switched-Currents: An Analogue Technique for Digital Technology*, Peter Peregrinus Ltd., London, ISBN 0-86341-294-7
- Vondraš J. & Martinek P. (2002). A Design of Active Filters with Corrected Group Delay by Means of the EDE Method (in Czech), *Proceedings of NSSS VI.*, vol. 1, pp. 36–39, Military Academy, Liptovský Mikuláš, ISBN 80-8040-180-2
- Waterloo Maple, Inc.: <http://www.maplesoft.com>
- Žiška P. & Vrbata J. (2006). Method for design of analog group delay equalizers, *Proceedings of conference ISCAS 2006*, pp. 445–448, IEEE, ISBN 0-7803-9389-9

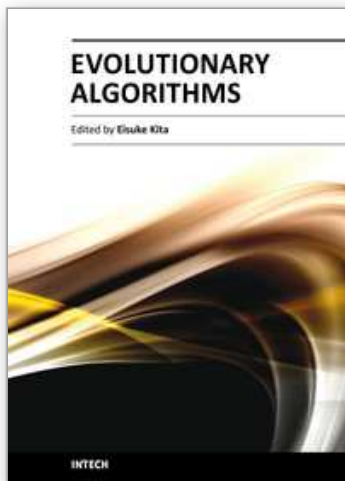

Evolutionary Algorithms

Edited by Prof. Eisuke Kita

ISBN 978-953-307-171-8

Hard cover, 584 pages

Publisher InTech

Published online 26, April, 2011

Published in print edition April, 2011

Evolutionary algorithms are successively applied to wide optimization problems in the engineering, marketing, operations research, and social science, such as include scheduling, genetics, material selection, structural design and so on. Apart from mathematical optimization problems, evolutionary algorithms have also been used as an experimental framework within biological evolution and natural selection in the field of artificial life.

How to reference

In order to correctly reference this scholarly work, feel free to copy and paste the following:

Lukáš Dořivka and Jiří Hospodka (2011). Using Evolutionary Algorithms for Optimization of Analogue Electronic Filters, Evolutionary Algorithms, Prof. Eisuke Kita (Ed.), ISBN: 978-953-307-171-8, InTech, Available from: <http://www.intechopen.com/books/evolutionary-algorithms/using-evolutionary-algorithms-for-optimization-of-analogue-electronic-filters>

INTECH
open science | open minds

InTech Europe

University Campus STeP Ri
Slavka Krautzeka 83/A
51000 Rijeka, Croatia
Phone: +385 (51) 770 447
Fax: +385 (51) 686 166
www.intechopen.com

InTech China

Unit 405, Office Block, Hotel Equatorial Shanghai
No.65, Yan An Road (West), Shanghai, 200040, China
中国上海市延安西路65号上海国际贵都大饭店办公楼405单元
Phone: +86-21-62489820
Fax: +86-21-62489821

© 2011 The Author(s). Licensee IntechOpen. This chapter is distributed under the terms of the [Creative Commons Attribution-NonCommercial-ShareAlike-3.0 License](#), which permits use, distribution and reproduction for non-commercial purposes, provided the original is properly cited and derivative works building on this content are distributed under the same license.

IntechOpen

IntechOpen