

We are IntechOpen, the world's leading publisher of Open Access books Built by scientists, for scientists

4,800

Open access books available

122,000

International authors and editors

135M

Downloads

Our authors are among the

154

Countries delivered to

TOP 1%

most cited scientists

12.2%

Contributors from top 500 universities



WEB OF SCIENCE™

Selection of our books indexed in the Book Citation Index
in Web of Science™ Core Collection (BKCI)

Interested in publishing with us?
Contact book.department@intechopen.com

Numbers displayed above are based on latest data collected.

For more information visit www.intechopen.com



New Method to Generate Balanced 2^n -PSK STTCs

P. Viland, G. Zaharia and J.-F. Hélar

Université européenne de Bretagne (UEB)

Institute of Electronics and Telecommunications of Rennes (IETR)

INSA de Rennes, 20 avenue des Buttes de Coesmes,

F-35708 Rennes

France

1. Introduction

The use of multiple input multiple output (MIMO) is an efficient method to improve the error performance of wireless communications. Tarokh et al. (1998) propose the space-time trellis codes (STTCs) which use trellis-coded modulations (TCM) over MIMO channels. STTCs combine diversity gain and coding gain leading to a reduction of the error probability.

In order to evaluate the performance of STTCs in slow fading channels, the rank and determinant criteria are proposed by Tarokh et al. (1998). In the case of fast fading channels, Tarokh et al. (1998) also present two criteria based on the Hamming distance and the distance product. Ionescu (1999) shows that the Euclidean distance can be used to evaluate the performance of STTCs. Based on the Euclidean distance, Chen et al. (2001) present the trace criterion which governs the performance of STTCs in both slow and fast fading channels, in the case of a great product between the number of transmit and receive antennas. This configuration corresponds to a great number of independent single input single output sub-channels. Liao & Prabhu (2005) explain that the repartition of determinants or Euclidean distances optimizes the performance of STTCs.

Based on these criteria, many codes have been proposed in the previous publications. The main difficulty is a long computing-time to find the best STTCs. Liao & Prabhu (2005) and Hong & Guillen i Fabregas (2007) use an exhaustive search to propose new STTCs, but only for 2 transmit antennas. To reduce the search-time, Chen et al. (2002a;b) advance a sub-optimal method to design STTCs. Thereby, the first STTCs with 3 and 4 transmit antennas are designed. Besides, another method is presented by Abdool-Rassool et al. (2004) where the first STTCs with 5 and 6 transmit antennas are given.

It has been remarked by Ngo et al. (2008; 2007) that the best codes have the same property: the used points of the MIMO constellation are generated with the same probability when the binary input symbols are equiprobable. The codes fulfilling this property are called balanced codes. This concept is also used by set partitioning proposed by Ungerboeck (1987a;b).

Thus, to find the best STTCs, it is sufficient to design and to analyze only the balanced codes. Hence, the time to find the best STTCs is significantly reduced. A first method to design balanced codes is proposed by Ngo et al. (2008; 2007) allowing to find 4-PSK codes with better performance than the previous published STTCs. Nevertheless, this method has been exploited only for the 4-PSK modulation.

The main goal of this chapter is to present a new efficient method to create 2^n -PSK balanced STTCs and thereby to propose new STTCs which outperform the previous published STTCs. The chapter is organized as follows. The next section reminds the representation of STTCs. The existing design criteria is presented in section 3. The properties of the balanced STTCs and the existing method to design these codes are given in section 4. In section 5, the new method is presented and illustrated with examples. In the last section, the performance of new STTCs is compared to the performance of the best published STTCs.

2. System model

In the case of 4-PSK modulation, i.e. $n = 2$, we consider the space-time trellis encoder presented in Fig. 1.

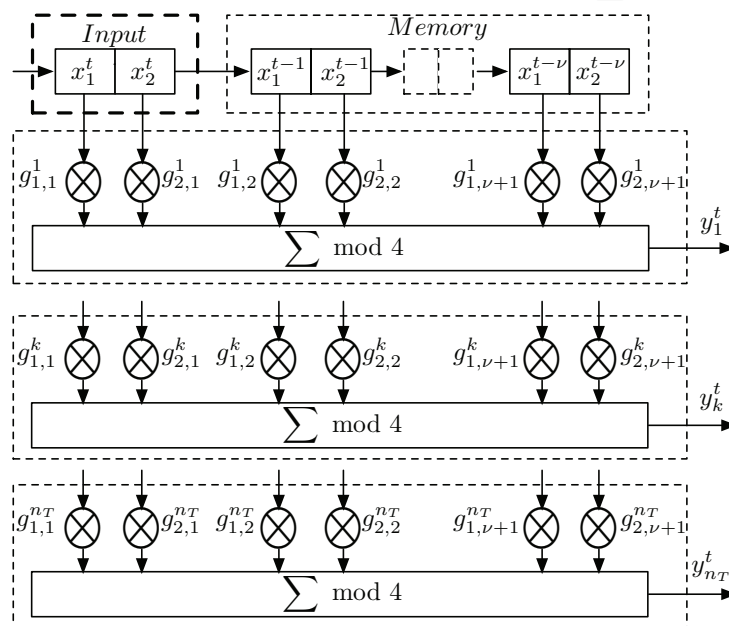

Fig. 1. 4^v states 4-PSK space-time trellis encoder

In general, a 2^{nv} states 2^n -PSK space-time trellis encoder with n_T transmit antennas is composed of one input block of n bits and v memory blocks of n bits. At each time $t \in \mathbb{Z}$, all the bits of a block are replaced by the n bits of the previous block. For each block i , with $i = \overline{1, \nu+1}$ where $\overline{1, \nu+1} = 1, 2, \dots, \nu+1$, the l^{th} bit with $l = \overline{1, n}$ is associated to n_T coefficients $g_{l,i}^k \in \mathbb{Z}_{2^n}$ with $k = \overline{1, n_T}$. With these $n_T \times n(\nu+1)$ coefficients, the generator matrix \mathbf{G} is obtained and given by

$$\mathbf{G} = \begin{bmatrix} g_{1,1}^1 & \cdots & g_{n,1}^1 & \cdots & g_{1,\nu+1}^1 & \cdots & g_{n,\nu+1}^1 \\ \vdots & & & & & & \vdots \\ g_{1,1}^k & \cdots & g_{n,1}^k & \cdots & g_{1,\nu+1}^k & \cdots & g_{n,\nu+1}^k \\ \vdots & & & & & & \vdots \\ g_{1,1}^{n_T} & \cdots & g_{n,1}^{n_T} & \cdots & g_{1,\nu+1}^{n_T} & \cdots & g_{n,\nu+1}^{n_T} \end{bmatrix}. \quad (1)$$

A state is defined by the binary values of the memory cells corresponding to no-null columns of \mathbf{G} . At each time t , the encoder output $Y^t = [y_1^t y_2^t \cdots y_{n_T}^t]^T \in \mathbb{Z}_{2^n}^{n_T}$ is given by

$$Y^t = \mathbf{G}X^t, \tag{2}$$

where $X^t = [x_1^t \cdots x_n^t \cdots x_1^{t-\nu} \cdots x_n^{t-\nu}]^T$ is the extended-state at time t of the $L_r = n(\nu + 1)$ length shift register realized by the input block followed by the ν memory blocks. The matrix $[\cdot]^T$ is the transpose of $[\cdot]$. Thus, STTCs can be defined by a function

$$\Phi : \mathbb{Z}_{2^n}^{L_r} \rightarrow \mathbb{Z}_{2^n}^{n_T}. \tag{3}$$

The 2^n -PSK signal sent to the k^{th} transmit antenna at time t is given by $s_k^t = \exp(j\frac{\pi}{2^{n-1}}y_k^t)$, with $j^2 = -1$. Thus, the MIMO symbol transmitted over the fading MIMO channel is given by $S^t = [s_1^t s_2^t \cdots s_{n_T}^t]^T$.

For the transmission of an input binary frame of $L_b \in \mathbb{N}^*$ bits, where L_b is a multiple of n , the first and the last state of the encoder are the null state. At each time t , n bits of the input binary frame feed into the encoder. Hence, $L = \frac{L_b}{n} + \nu$ MIMO symbols regrouped in the codeword

$$\mathbf{S} = [S^1 \cdots S^t \cdots S^L] \tag{4}$$

$$= \begin{bmatrix} s_1^1 & \cdots & s_1^t & \cdots & s_1^L \\ \vdots & \ddots & \vdots & \ddots & \vdots \\ s_k^1 & \cdots & s_k^t & \cdots & s_k^L \\ \vdots & \ddots & \vdots & \ddots & \vdots \\ s_{n_T}^1 & \cdots & s_{n_T}^t & \cdots & s_{n_T}^L \end{bmatrix} \tag{5}$$

are sent to the MIMO channel.

The vector of the signals received at time t by the n_R receive antennas $R^t = [r_1^t \cdots r_{n_R}^t]^T$ can be written as

$$R^t = \mathbf{H}^t S^t + N^t, \tag{6}$$

where $N^t = [n_1^t \cdots n_{n_R}^t]^T$ is the vector of complex additive white gaussian noises (AWGN) at time t . The $n_R \times n_T$ matrix \mathbf{H}^t representing the complex path gains of the SISO channels between the transmit and receive antennas at time t is given by

$$\mathbf{H}^t = \begin{bmatrix} h_{1,1}^t & \cdots & h_{1,n_T}^t \\ \vdots & \ddots & \vdots \\ h_{n_R,1}^t & \cdots & h_{n_R,n_T}^t \end{bmatrix}. \tag{7}$$

In this chapter, only the case of Rayleigh fading channels is considered. The path gain $h_{k',k}^t$ of the SISO channel between the k^{th} transmit antenna and $(k')^{th}$ receive antenna is a complex random variable. The real and the imaginary parts of $h_{k',k}^t$ are zero-mean Gaussian random variables with the same variance. Two types of Rayleigh fading channels can be considered:

- Slow Rayleigh fading channels: the complex path gains of the channels do not change during the transmission of the symbols of the same codeword.
- Fast Rayleigh fading channels: the complex path gains of the channels change independently at each time t .

3. Performance criteria

The main goal of this design is to reduce the pairwise error probability (PEP) which is the probability that the decoder selects an erroneous codeword \mathbf{E} while a different codeword \mathbf{S} was transmitted. We consider a codeword of L MIMO signals starting at $t = 1$ by a $n_T \times L$ matrix $\mathbf{S} = [S^1 S^2 \dots S^L]$ where S^t is the t^{th} MIMO signal. An error occurs if the decoder decides that another codeword $\mathbf{E} = [E^1 E^2 \dots E^L]$ is transmitted. Let us define the $n_T \times L$ difference matrix

$$\mathbf{B} = \mathbf{E} - \mathbf{S} = \begin{bmatrix} e_1^1 - s_1^1 & \dots & e_1^L - s_1^L \\ \vdots & \ddots & \vdots \\ e_{n_T}^1 - s_{n_T}^1 & \dots & e_{n_T}^L - s_{n_T}^L \end{bmatrix}. \quad (8)$$

The $n_T \times n_T$ product matrix $\mathbf{A} = \mathbf{B}\mathbf{B}^*$ is introduced, where \mathbf{B}^* denotes the hermitian of \mathbf{B} . The minimum rank of \mathbf{A} $r = \min(\text{rank}(\mathbf{A}))$, computed for all pairs (\mathbf{E}, \mathbf{S}) of different codewords is defined. The design criteria depend on the value of the product rn_R .

First case: $rn_R \leq 3$:

In this case, for slow Rayleigh fading channels, two criteria have been proposed by Tarokh et al. (1998) and Liao & Prabhu (2005) to reduce the PEP:

- \mathbf{A} has to be a full rank matrix for any pair (\mathbf{E}, \mathbf{S}) . Since the maximal value of r is n_T , the achievable spatial diversity order is $n_T n_R$.
- The coding gain is related to the inverse of $\eta = \sum_d N(d) d^{-n_R}$, where $N(d)$ is defined as the average number of error events with a determinant d equal to

$$\begin{aligned} d &= \det(\mathbf{A}) = \prod_{k=1}^{n_T} \lambda_k \\ &= \prod_{k=1}^{n_T} \left(\sum_{t=1}^L |e_k^t - s_k^t|^2 \right). \end{aligned} \quad (9)$$

The best codes must have the minimum value of η .

In the case of fast Rayleigh fading channels, different criteria have been obtained by Tarokh et al. (1998). They define the Hamming distance $d_H(\mathbf{E}, \mathbf{S})$ between two codewords \mathbf{E} and \mathbf{S} as the number of time intervals for which $|E^t - S^t| \neq 0$. To maximize the diversity advantage, the minimal Hamming distance must be maximized for all pairs of codewords (\mathbf{E}, \mathbf{S}) . In this case, the achieved spatial diversity order is equal to $d_H(\mathbf{E}, \mathbf{S}) n_R$. In the same way, Tarokh et al. introduce the product distance $d_p^2(\mathbf{E}, \mathbf{S})$ given by

$$d_p^2(\mathbf{E}, \mathbf{S}) = \prod_{\substack{t=1 \\ E^t \neq S^t}}^L d_E^2(E^t, S^t), \quad (10)$$

where $d_E^2(E^t, S^t) = \sum_{k=1}^{n_T} |e_k^t - s_k^t|^2$ is the squared Euclidean distance between the MIMO signals

E^t and S^t at time t . In order to reduce the number of error events, $\min \{d_p^2(\mathbf{E}, \mathbf{S})\}$ must be maximized for all pairs (\mathbf{E}, \mathbf{S}) .

Second case: $rn_R \geq 4$:

Chen et al. (2001) show that for a large value of rn_R , which corresponds to a large number

of independent SISO channels, the PEP is minimized if the sum of all the eigenvalues of the matrices \mathbf{A} is maximized. Since \mathbf{A} is a square matrix, the sum of all the eigenvalues is equal to its trace

$$\text{tr}(\mathbf{A}) = \sum_{k=1}^{n_T} \lambda_k = \sum_{t=1}^L d_E^2(E^t, S^t). \quad (11)$$

For each pair of codewords, $\text{tr}(\mathbf{A})$ is computed. The minimum trace (which is the minimum value of the squared Euclidean distance between two codewords) is the minimum of all these values $\text{tr}(\mathbf{A})$. The concept of Euclidean distance for STTCs has been previously introduced by Ionescu (1999). The minimization of the PEP amounts to using a code which has the maximum value of the minimum Euclidean distance between two codewords. Liao & Prabhu (2005) state also that to minimize the frame error rate (FER), the number of error events with the minimum squared Euclidean distance between codewords has to be minimized.

In this paper, we consider only the case $rn_R \geq 4$ which is obtained when the rank of the STTCs is greater than or equal to 2 and there are at least 2 receive antennas.

4. Balanced STTCs

4.1 Definitions

The concept of "balanced codes" proposed by Ngo et al. (2008; 2007) is based on the observation that each good code has the same property given by the following definition.

Definition 1 (Number of occurrences). *The number of occurrences of a MIMO symbol is the number of times where the MIMO symbol is generated when we consider the entire set of the extended-states.*

Definition 2 (Balanced codes). *A code is balanced if and only if the generated MIMO symbols have the same number of occurrences $n_0 \in \mathbb{N}^*$, if the binary input symbols are equiprobable.*

Definition 3 (Fully balanced code). *A code is fully balanced if and only if the code is balanced and the set of generated MIMO symbols is $\Lambda = \mathbb{Z}_{2^n}^{n_T}$.*

Definition 4 (Minimal length code). *A code is a minimal length code if and only if the code is fully balanced and the number of occurrences of each MIMO symbol is $n_0 = 1$.*

To check that a code is balanced, the MIMO symbols generated by all the extended-states must be computed. Then, the number of occurrences of each MIMO symbol can be obtained.

For example, let us consider two generator matrices

$$\mathbf{G}_1 = \begin{bmatrix} 0 & 0 & 2 & 1 \\ 2 & 1 & 0 & 0 \end{bmatrix} \quad (12)$$

and

$$\mathbf{G}_2 = \begin{bmatrix} 0 & 0 & 2 & 1 \\ 3 & 1 & 0 & 0 \end{bmatrix}. \quad (13)$$

Remark: \mathbf{G}_1 is the generator matrix of the code proposed by Tarokh et al. (1998).

The repartition of MIMO symbols in function of extended-states is given in Tables 1 et 2 for the generator matrices \mathbf{G}_1 and \mathbf{G}_2 respectively. The decimal value of the extended-state $X^t = [x_1^t \ x_2^t \ x_1^{t-1} \ x_2^{t-1}]^T \in \mathbb{Z}_2^4$ is computed by considering x_1^t the most significant bit. The number

of occurrences of each generated MIMO symbol is also given in these tables. The generator matrix G_1 corresponds to a minimal length code, whereas G_2 corresponds to a no balanced code.

X^t	0	1	2	3	4	5	6	7	8	9	10	11	12	13	14	15
Y^t	$\begin{bmatrix} 0 \\ 0 \end{bmatrix}$	$\begin{bmatrix} 1 \\ 0 \end{bmatrix}$	$\begin{bmatrix} 2 \\ 0 \end{bmatrix}$	$\begin{bmatrix} 3 \\ 0 \end{bmatrix}$	$\begin{bmatrix} 0 \\ 1 \end{bmatrix}$	$\begin{bmatrix} 1 \\ 1 \end{bmatrix}$	$\begin{bmatrix} 2 \\ 1 \end{bmatrix}$	$\begin{bmatrix} 3 \\ 1 \end{bmatrix}$	$\begin{bmatrix} 0 \\ 2 \end{bmatrix}$	$\begin{bmatrix} 1 \\ 2 \end{bmatrix}$	$\begin{bmatrix} 2 \\ 2 \end{bmatrix}$	$\begin{bmatrix} 3 \\ 2 \end{bmatrix}$	$\begin{bmatrix} 0 \\ 3 \end{bmatrix}$	$\begin{bmatrix} 1 \\ 3 \end{bmatrix}$	$\begin{bmatrix} 2 \\ 3 \end{bmatrix}$	$\begin{bmatrix} 3 \\ 3 \end{bmatrix}$
occurrences	1	1	1	1	1	1	1	1	1	1	1	1	1	1	1	1

Table 1. MIMO symbols generated by G_1

X^t	0 12	1 13	2 14	3 15	4	5	6	7	8	9	10	11
Y	$\begin{bmatrix} 0 \\ 0 \end{bmatrix}$	$\begin{bmatrix} 1 \\ 0 \end{bmatrix}$	$\begin{bmatrix} 2 \\ 0 \end{bmatrix}$	$\begin{bmatrix} 3 \\ 0 \end{bmatrix}$	$\begin{bmatrix} 0 \\ 1 \end{bmatrix}$	$\begin{bmatrix} 1 \\ 1 \end{bmatrix}$	$\begin{bmatrix} 2 \\ 1 \end{bmatrix}$	$\begin{bmatrix} 3 \\ 1 \end{bmatrix}$	$\begin{bmatrix} 0 \\ 3 \end{bmatrix}$	$\begin{bmatrix} 1 \\ 3 \end{bmatrix}$	$\begin{bmatrix} 2 \\ 3 \end{bmatrix}$	$\begin{bmatrix} 3 \\ 3 \end{bmatrix}$
Nb occurrences	2	2	2	2	1	1	1	1	1	1	1	1

Table 2. MIMO symbols generated by G_2

4.2 Properties of $\mathbb{Z}_{2^n}^{n_T}$

We define the subgroup C_0 of $\mathbb{Z}_{2^n}^{n_T}$ by

$$C_0 = 2^{n-1}\mathbb{Z}_2^{n_T}. \tag{14}$$

Property 1. $\forall V \in C_0, V = -V$ with $V + (-V) = [0 \dots 0]^T$.

Proof. Let us consider $V \in C_0$. As $C_0 = 2^{n-1}\mathbb{Z}_2^{n_T}$,

$$V = 2^{n-1}q \in C_0 \text{ with } q \in \mathbb{Z}_2^{n_T}. \tag{15}$$

Therefore

$$V + V = 2^n q = 0 \in \mathbb{Z}_{2^n}^{n_T} \pmod{2^n}. \tag{16}$$

Thus, it exists $V' = V$ such as $V + V' = 0 \in \mathbb{Z}_{2^n}^{n_T}$. Hence, $-V = V, \forall V \in C_0$. \square

Besides, it is possible to make a partition of the group $\mathbb{Z}_{2^n}^{n_T}$ into $2^{n_T(n-1)}$ cosets, as presented by Coleman (2002) such as

$$\mathbb{Z}_{2^n}^{n_T} = \bigcup_{P \in \mathbb{Z}_{2^n}^{n_T}} C_P, \tag{17}$$

where P is a coset representative of the coset $C_P = P + C_0$. Based on these cosets, another partition can be created and given by

$$\mathbb{Z}_{2^n}^{n_T} = \bigcup_{q=0}^{n-1} \mathcal{E}_q, \tag{18}$$

where $\mathcal{E}_0 = C_0$. For $q = \overline{1, n-1}$, the other \mathcal{E}_q are defined by

$$\mathcal{E}_q = \bigcup_{P_q} (P_q + C_0) = \bigcup_{P_q} C_{P_q}, \tag{19}$$

where $P_q \in 2^{n-q-1}\mathbb{Z}_{2^q}^{n_T} \setminus 2^{n-q}\mathbb{Z}_{2^{q-1}}^{n_T}$. The set $\mathbb{Z}_1^{n_T}$ contains only the nul element of $\mathbb{Z}_{2^n}^{n_T}$.

Definition 5. Let us consider a subgroup Λ of $\mathbb{Z}_{2^n}^{n_T}$. A coset $C_P = P + \Lambda$ with $P \in \mathbb{Z}_{2^n}^{n_T}$ is relative to $Q \in \Lambda$ if and only if $2P = Q$.

Thus, for $q = \overline{2, n-1}$, each coset $C_{P_q} = P_q + C_0 \subset \mathcal{E}_q$ is relative to $R = 2P_q \in \mathcal{E}_{q-1}$.

For example, it is possible to make a partition of the group $\mathbb{Z}_{2^n}^{n_T}$ which is the set of 4-PSK MIMO symbols with 2 transmit antennas. This partition is represented in Table 3.

$\varepsilon_0 : C_0$	$\begin{bmatrix} 0 \\ 0 \end{bmatrix}$	$\begin{bmatrix} 0 \\ 2 \end{bmatrix}$	$\begin{bmatrix} 2 \\ 0 \end{bmatrix}$	$\begin{bmatrix} 2 \\ 2 \end{bmatrix}$
$\varepsilon_1 :$	$C_{\begin{bmatrix} 0 \\ 1 \end{bmatrix}}$	$\begin{bmatrix} 0 \\ 1 \end{bmatrix}$	$\begin{bmatrix} 0 \\ 3 \end{bmatrix}$	$\begin{bmatrix} 2 \\ 1 \end{bmatrix}$
	$C_{\begin{bmatrix} 1 \\ 0 \end{bmatrix}}$	$\begin{bmatrix} 1 \\ 0 \end{bmatrix}$	$\begin{bmatrix} 1 \\ 2 \end{bmatrix}$	$\begin{bmatrix} 3 \\ 0 \end{bmatrix}$
	$C_{\begin{bmatrix} 1 \\ 1 \end{bmatrix}}$	$\begin{bmatrix} 1 \\ 1 \end{bmatrix}$	$\begin{bmatrix} 1 \\ 3 \end{bmatrix}$	$\begin{bmatrix} 3 \\ 1 \end{bmatrix}$

Table 3. Partition of \mathbb{Z}_4^2

The red coset $C_{\begin{bmatrix} 0 \\ 1 \end{bmatrix}} = \begin{bmatrix} 0 \\ 1 \end{bmatrix} + C_0$ is relative to the red element $\begin{bmatrix} 0 \\ 2 \end{bmatrix} \in C_0$. The green coset $C_{\begin{bmatrix} 1 \\ 0 \end{bmatrix}} = \begin{bmatrix} 1 \\ 0 \end{bmatrix} + C_0$ is relative to the green element $\begin{bmatrix} 2 \\ 0 \end{bmatrix} \in C_0$. The yellow coset $C_{\begin{bmatrix} 1 \\ 1 \end{bmatrix}} = \begin{bmatrix} 1 \\ 1 \end{bmatrix} + C_0$ is relative to the yellow element $\begin{bmatrix} 2 \\ 2 \end{bmatrix} \in C_0$.

Property 2. If Λ_l is a subgroup of $\mathbb{Z}_{2^n}^{n_T}$ given by

$$\Lambda_l = \left\{ \sum_{m=1}^l x_m V_m \text{ mod } 2^n / x_m \in \{0, 1\} \right\}, l \in \{1, 2, \dots, nn_T\} \tag{20}$$

with $V_m \in \mathbb{Z}_{2^n}^{n_T}$ and if the number of occurrences of each MIMO symbol $V \in \Lambda_l$ is $n(V) = n_0 = 1$ i.e. $\text{card}(\Lambda_l) = 2^l$, then there is at least one element V_m which belongs to C_0^* .

Proof. The Lagrange’s theorem states that for a finite group Λ , the order of each subgroup Λ_l of Λ divides the order of Λ . In the case of 2^n -PSK, $\text{card}(\Lambda) = \text{card}(\mathbb{Z}_{2^n}^{n_T}) = 2^{nn_T}$, then $\text{card}(\Lambda_l) = 2^l$. Hence, $\text{card}(\Lambda_l)$ is a even number. The null element belongs to Λ_l and the opposite of each element is included in Λ_l . Thus, in order to obtain an even number for $\text{card}(\Lambda_l)$, there are at least one element $V_m \neq 0$ which respects $V_m = -V_m$. Only the elements of C_0 respect $V_m = -V_m$. Therefore, there is at least one element $V_m \in C_0^*$. \square

Definition 6 (Linearly independent vectors). If $\text{card}(\Lambda_l) = 2^l$, the vectors V_1, V_2, \dots, V_l are linearly independent. Hence, they form a base of Λ_l .

Remarks :

1. $\min \{l \in \mathbb{N} \mid \Lambda_l = \mathbb{Z}_{2^n}^{n_T}\} = nn_T = L_{min} = \dim(\mathbb{Z}_{2^n}^{n_T})$ i.e. nn_T is a minimal number of vectors giving a fully balanced code.
2. nn_T is the maximal number of vectors to obtain a number of occurrences $n(V) = n_0 = 1, \forall V \in \Lambda_l$.

Property 3. To generate a subgroup $\Lambda_l = \left\{ \sum_{m=1}^l x_m V_m \text{ mod } 2^n / x_m \in \{0,1\} \right\}$ with $V_m \in \mathbb{Z}_{2^n}^{n_T}$, $l \in \{1, 2, \dots, nn_T\}$ and $\text{card}(\Lambda_l) = 2^l$, the elements V_m must be selected as follows:

- The first element V_1 must belong to C_0^* .
- If $m - 1$ elements V_1, V_2, \dots, V_{m-1} have been already selected with $m \in \{2 \dots l\}$, the m^{th} element V_m must not belong to

$$\Lambda_{m-1} = \left\{ \sum_{m'=1}^{m-1} x_{m'} V_{m'} \text{ mod } 2^n / x_{m'} \in \{0,1\} \right\} \quad (21)$$

and must belong to C_0^* or to the cosets relative to an element of Λ_{m-1} .

Proof. As shown by property 2, there is at least one element which belongs to C_0^* . Thus, if $V_1 \in C_0^*$, $\Lambda_1 = \{0, V_1\}$ is a subgroup of $\mathbb{Z}_{2^n}^{n_T}$.

We consider that $m - 1$ elements have been selected to generate a subgroup Λ_{m-1} with $m = \{2, \dots, nn_T\}$.

If we select $V_m \in \mathbb{Z}_{2^n}^{n_T} \setminus \Lambda_{m-1}$ such as $2V_m = Q \in \Lambda_{m-1}$, a set Λ_m is defined by

$$\Lambda_m = \Lambda_{m-1} \cup C_{V_m} \quad (22)$$

where C_{V_m} is the coset defined by

$$C_{V_m} = V_m + \Lambda_{m-1}. \quad (23)$$

In order to show that Λ_m is a subgroup of $\mathbb{Z}_{2^n}^{n_T}$, the following properties must be proved:

1. $0 \in \Lambda_m$. *Proof:* As $\Lambda_m = \Lambda_{m-1} \cup (\Lambda_{m-1} + V_m)$ and $0 \in \Lambda_{m-1}$, we have $0 \in \Lambda_m$.
2. $\forall V_1, V_2 \in \Lambda_m, V_1 + V_2 \in \Lambda_m$. Three cases must be considered.
 - 1st case: $V_1, V_2 \in \Lambda_{m-1}$. In this case, as Λ_{m-1} is a subgroup $V_1 + V_2 \in \Lambda_{m-1} \subset \Lambda_m$.
 - 2st case: $V_1, V_2 \in C_{V_m}$. In this case, $V_1 = V_m + Q_1$ and $V_2 = V_m + Q_2$ with $Q_1, Q_2 \in \Lambda_{m-1}$. Thus, $V_1 + V_2 = 2V_m + Q_1 + Q_2$. As $2V_m \in \Lambda_{m-1}$ and Λ_{m-1} is a subgroup, $V_1 + V_2 \in \Lambda_{m-1} \subset \Lambda_m$.
 - 3rd case: $V_1 \in \Lambda_{m-1}$ and $V_2 \in C_{V_m}$. In this case, $V_2 = V_m + Q_2$, with $Q_2 \in \Lambda_{m-1}$. We have $V_1 + V_2 = V_1 + V_m + Q_2 = V_m + (V_1 + Q_2) \in C_{V_m} \subset \Lambda_m$ because $V_1 + Q_2 \in \Lambda_{m-1}$ (Λ_{m-1} is a subgroup).

Thus, Λ_m is a closed set under addition.

3. $\forall V \in \Lambda_m, \exists -V \in \Lambda_m$ such as $V + (-V) = 0$.

Proof: Two cases must be considered.

1st case: $V \in \Lambda_{m-1}$.

In this case, as Λ_{m-1} is a subgroup, so $-V \in \Lambda_{m-1} \subset \Lambda_m$.

2^{nd} case: $V \in \mathcal{C}_{m-1}$.

In this case, $V = V_m + Q$ with $Q \in \Lambda_{m-1}$. Because Λ_{m-1} is a subgroup, $-Q = -V_m + (-V_m) = -2V_m \in \Lambda_{m-1}$ with $V_m + (-V_m) = 0$ and $Q + (-Q) = 0$. Thus, we have

$$-V_m = V_m + (-2V_m) = V_m + (-Q) \in \mathcal{C}_{V_m} \subset \Lambda_m. \tag{24}$$

Hence $-V = -V_m + (-Q) = V_m + (-Q) + (-Q) \in \mathcal{C}_m \subset \Lambda_m$ because $(-Q) + (-Q) \in \Lambda_{m-1}$.

Thus, the opposite of each element of Λ_m belongs to Λ_m .

In conclusion, if each new element is selected within a coset relative to a generated element, the created set Λ_m is also a subgroup. □

4.3 Properties of balanced STTCs

Each MIMO symbol belongs to $\mathbb{Z}_{2^n}^{n_T}$. At each time t , the generated MIMO symbol is given by the value of extended-state X^t and the generator matrix \mathbf{G} . In this section, several properties of the generator matrix are given in order to reduce the search-time.

Property 4. For a fully balanced code, the number of columns of the generator matrix \mathbf{G} is $L_r \geq L_{min} = nn_T$. As shown by the definition (4), if \mathbf{G} has L_{min} columns, then the code is a minimal length code.

Proof. Let us consider the generator matrix \mathbf{G} of a 2^n -PSK 2^{L_r-n} states STTC with n_T transmit antennas. The extended-state can use 2^{L_r} binary value. The maximal number of generated MIMO symbols is given by

$$\sum_{Y \in \mathbb{Z}_{2^n}^{n_T}} n(Y) = 2^{L_r}. \tag{25}$$

\mathbf{G} is the generator matrix of a fully balanced code, $\forall Y \in \mathbb{Z}_{2^n}^{n_T}$, $n(Y) = n_0$. The number of possible MIMO symbols is $\text{card}(\mathbb{Z}_{2^n}^{n_T}) = 2^{nn_T}$. Thus, the previous expression is

$$n_0 2^{nn_T} = 2^{L_r}. \tag{26}$$

The number of occurrences of each $Y \in \mathbb{Z}_{2^n}^{n_T}$, $n(Y) \geq 1$, so $2^{L_r} \geq \text{card}(\mathbb{Z}_{2^n}^{n_T}) = nn_T$. Therefore $L_r \geq L_{min} = nn_T$. □

Property 5. If \mathbf{G} is the generator matrix with L_r columns of a fully balanced code, for any additional column $G_{L_r+1} \in \mathbb{Z}_{2^n}^{n_T}$, the resulting generator matrix $\mathbf{G}' = [\mathbf{G} \ G_{L_r+1}]$ corresponds to a new fully balanced code.

Proof. For a fully balanced code, the generated MIMO symbols belong to $\Lambda_{L_r} = \mathbb{Z}_{2^n}^{n_T}$. If a new column $G_{L_r+1} \in \mathbb{Z}_{2^n}^{n_T}$ is added to \mathbf{G} , the new set of columns generates $\Lambda_{L_r+1} = \Lambda_{L_r} \cup (\Lambda_{L_r} + G_{L_r+1})$. As $G_{L_r+1} \in \mathbb{Z}_{2^n}^{n_T}$ and $\mathbb{Z}_{2^n}^{n_T}$ is a group, $\Lambda_{L_r} + G_{L_r+1} = \Lambda_{L_r}$. Thereby, $\Lambda_{L_r+1} = \mathbb{Z}_{2^n}^{n_T}$. The number of occurrences of the elements belonging to Λ_{L_r} is n_0 . The number of occurrences of the elements belonging to $\Lambda_{L_r} + G_{L_r+1}$ is also n_0 . Thus, for each new column of the fully balanced code, the number of occurrences of the elements of the new code is $2n_0$. □

Property 6. If \mathbf{G} is the matrix of a balanced code, each permutation of columns or/and lines generates the generator matrix of a new balanced code.

Proof. The set of MIMO symbols belongs to a subgroup of the commutative group $\mathbb{Z}_{2^n}^{n_T}$. Therefore, the permutations between the columns of the generator matrix generate the same MIMO symbols. So, the new codes are also balanced.

A permutation of lines of the generator matrix corresponds to a permutation of the transmit antennas. If the initial code is balanced, the code will be balanced. \square

5. New method to generate the balanced codes

5.1 Generation of the fully balanced codes

The property 5 states that the minimal length code is the first step to create any fully balanced code. In fact, for each column added to the generator matrix of a fully balanced code, the new code is also fully balanced. Thus, only the generation of minimal length codes is presented. To create a minimal length STTC, the columns G_i with $i = \overline{1, n n_T}$ must be selected with the following rules.

Rule 1. The first column G_1 must be selected within C_0^* . This first selection creates the subgroup $\Lambda_1 = \{0, G_1\}$.

Rule 2. If the first $m \in \{1, 2, \dots, L_{min} - 1\}$ columns of the generator matrix have been selected to generate a subgroup $\Lambda_m = \left\{ \sum_{m'=1}^m x_{m'} G_{m'} \bmod 2^n / x_{m'} \in \{0, 1\} \right\}$ of $\mathbb{Z}_{2^n}^{n_T}$, the add of next column G_{m+1} create a new subgroup Λ_{m+1} of $\mathbb{Z}_{2^n}^{n_T}$ with $\text{card}(\Lambda_{m+1}) = 2\text{card}(\Lambda_m)$. Hence, the column G_{m+1} of \mathbf{G} must be selected in $\mathbb{Z}_{2^n}^{n_T} \setminus \Lambda_m$ in a coset relative to an element of Λ_m or in C_0^* .

If this algorithm is respected, the new generated set

$$\Lambda_{m+1} = \Lambda_m \cup (\Lambda_m + G_m) \quad (27)$$

is a subgroup of $\mathbb{Z}_{2^n}^{n_T}$.

Thereby, as presented by Forney (1988), a chain partition of $\mathbb{Z}_{2^n}^{n_T}$

$$\Lambda_1 / \Lambda_2 \cdots / \Lambda_m / \cdots / \Lambda_{L_{min}} \quad (28)$$

is obtained with $\text{card}(\Lambda_{m+1}) = 2\text{card}(\Lambda_m)$. Since $\text{card}(\Lambda_1) = 2$, then the L_{min} columns generate a subgroup $\Lambda_{L_{min}}$ with $\text{card}(\Lambda_{L_{min}}) = 2^{L_{min}}$.

To obtain a fully balanced code with a generator matrix with $L_r > L_{min}$, it is sufficient to add new columns which belong to $\mathbb{Z}_{2^n}^{n_T}$.

The main advantage of this method is to define distinctly the set where each new column of \mathbf{G} must be selected. In the first method presented by Ngo et al. (2008; 2007), the linear combination of the generated and selected elements and their opposites must be blocked, i.e. these elements must not be further selected. Due to the new method, there are no blocked elements. This is a significant simplification of the first method.

5.2 Generation of the balanced codes

This section treats the generation of balanced STTCs (not fully balanced STTCs) i.e. the set of the generated MIMO symbols is a subset of the group $\mathbb{Z}_{2^n}^{n_T}$ and not the entire set $\mathbb{Z}_{2^n}^{n_T}$.

For the generation of these STTCs with the generator matrix constituted by L_r columns, the algorithm which is presented in the previous section must be used for the selection of the first $m_0 \leq \min(L_{min} - 2, L_r)$ columns. Thus,

- The m_0 first columns G_1, G_2, \dots, G_{m_0} must be selected with the Rules 1 and 2. Hence, the set generated by the first m_0 columns is the subgroup

$$\Lambda_{m_0} = \left\{ \sum_{m=1}^{m_0} x_m G_m \bmod 2^n / x_m \in \{0, 1\} \right\}. \tag{29}$$

The number of occurrences of each MIMO symbol $V \in \Lambda_{m_0}$ is 1.

- The columns $G_{m_0+1} \dots G_{L_r-1}$ must be selected in the subgroup Λ_{m_0} . Thus, the subgroup created by the $L_r - 1$ first columns is $\Lambda_{L_r-1} = \Lambda_{m_0}$, but the number of occurrences of each MIMO symbol is $2^{L_r-m_0-1}, \forall Y \in \Lambda_{m_0}$.
- The last column must be selected everywhere in $\mathbb{Z}_{2^n}^{n_T}$. Two cases can be analyzed :
 - If $G_{L_r} \in \Lambda_{L_r-1}$, then the number of occurrences of each element is multiplied by two. The resulting code is also balanced. In this case, the set of generated MIMO symbols is the subgroup Λ_{L_r-1} .
 - If $G_{L_r} \in \mathbb{Z}_{2^n}^{n_T} \setminus \Lambda_{L_r-1}$, the generated set $\Lambda_{L_r} = \Lambda_{L_r-1} \cup (\Lambda_{L_r-1} + G_{L_r})$ is not necessarily a subgroup of $\mathbb{Z}_{2^n}^{n_T}$. Each element of the generated set has $2^{L_r-m_0-1}, \forall Y \in \Lambda_{L_r}$, but $\text{card}(\Lambda_{L_r}) = 2\text{card}(\Lambda_{L_r-1})$.

5.3 Example of the generation of a fully balanced 64 states 4-PSK STTC with 3 transmit antennas

The generator matrix of the 64 states 4-PSK STTCs with 3 transmit antennas is

$$\mathbf{G} = [G_1 G_2 | G_3 G_4 | G_5 G_6 | G_7 G_8] \tag{30}$$

with $G_i \in [G_i^1 G_i^2 G_i^3]^T \in \mathbb{Z}_4^3$ for $i = \overline{1, 8}$. In order to create a fully balanced 64 states 4-PSK STTC with 3 transmit antennas, 8 elements must be selected in \mathbb{Z}_4^3 . The first element must belong to $\mathcal{C}_0^* = 2\mathbb{Z}_2^3 \setminus \{[0 \ 0 \ 0]^T\}$. The element $G_1 = \begin{bmatrix} 0 \\ 2 \\ 2 \end{bmatrix}$ can be selected. Thereby, the second column of \mathbf{G} must be selected either in \mathcal{C}_0^* or in the coset relative to G_1 . In Table 4, the green element represents the selected element and the blue element represent the generated element.

\mathcal{C}_0	$\begin{bmatrix} 0 \\ 0 \\ 0 \end{bmatrix}$	$\begin{bmatrix} 0 \\ 0 \\ 2 \end{bmatrix}$	$\begin{bmatrix} 0 \\ 2 \\ 0 \end{bmatrix}$	$\begin{bmatrix} 0 \\ 2 \\ 2 \end{bmatrix}$	$\begin{bmatrix} 2 \\ 0 \\ 0 \end{bmatrix}$	$\begin{bmatrix} 2 \\ 0 \\ 2 \end{bmatrix}$	$\begin{bmatrix} 2 \\ 2 \\ 0 \end{bmatrix}$	$\begin{bmatrix} 2 \\ 2 \\ 2 \end{bmatrix}$
$\mathcal{C}_0 \begin{bmatrix} 0 \\ 1 \\ 1 \end{bmatrix}$	$\begin{bmatrix} 0 \\ 1 \\ 1 \end{bmatrix}$	$\begin{bmatrix} 0 \\ 1 \\ 3 \end{bmatrix}$	$\begin{bmatrix} 0 \\ 3 \\ 1 \end{bmatrix}$	$\begin{bmatrix} 0 \\ 3 \\ 3 \end{bmatrix}$	$\begin{bmatrix} 2 \\ 1 \\ 1 \end{bmatrix}$	$\begin{bmatrix} 2 \\ 1 \\ 3 \end{bmatrix}$	$\begin{bmatrix} 2 \\ 3 \\ 1 \end{bmatrix}$	$\begin{bmatrix} 2 \\ 3 \\ 3 \end{bmatrix}$

Table 4. Selection of G_1 of \mathbf{G}

The next column G_2 of \mathbf{G} must be selected in the white set. If G_2 is selected into $\mathcal{C}_0 \begin{bmatrix} 0 \\ 1 \\ 1 \end{bmatrix}$, for example $\begin{bmatrix} 2 \\ 1 \\ 3 \end{bmatrix}$, the generated subgroup Λ_2 is represented by the colored elements of Table 5. No new element of \mathcal{C}_0 is generated. Thereby, G_3 must belong to \mathcal{C}_0^* or $\mathcal{C}_0 \begin{bmatrix} 0 \\ 1 \\ 1 \end{bmatrix}$ and must not belong to Λ_2 .

c_0	$\begin{bmatrix} 0 \\ 0 \\ 0 \end{bmatrix}$	$\begin{bmatrix} 0 \\ 0 \\ 2 \end{bmatrix}$	$\begin{bmatrix} 0 \\ 2 \\ 0 \end{bmatrix}$	$\begin{bmatrix} 0 \\ 2 \\ 2 \end{bmatrix}$	$\begin{bmatrix} 2 \\ 0 \\ 0 \end{bmatrix}$	$\begin{bmatrix} 2 \\ 0 \\ 2 \end{bmatrix}$	$\begin{bmatrix} 2 \\ 2 \\ 0 \end{bmatrix}$	$\begin{bmatrix} 2 \\ 2 \\ 2 \end{bmatrix}$
$c \begin{bmatrix} 0 \\ 1 \\ 1 \end{bmatrix}$	$\begin{bmatrix} 0 \\ 1 \\ 1 \end{bmatrix}$	$\begin{bmatrix} 0 \\ 1 \\ 3 \end{bmatrix}$	$\begin{bmatrix} 0 \\ 3 \\ 1 \end{bmatrix}$	$\begin{bmatrix} 0 \\ 3 \\ 3 \end{bmatrix}$	$\begin{bmatrix} 2 \\ 1 \\ 1 \end{bmatrix}$	$\begin{bmatrix} 2 \\ 1 \\ 3 \end{bmatrix}$	$\begin{bmatrix} 2 \\ 3 \\ 1 \end{bmatrix}$	$\begin{bmatrix} 2 \\ 3 \\ 3 \end{bmatrix}$

Table 5. Selection of G_2 of \mathbf{G}

The 3rd element can be $G_3 = \begin{bmatrix} 0 \\ 0 \\ 2 \end{bmatrix}$. As presented in Table 6, two new elements of \mathcal{C}_0 are generated (or selected). Thus, G_4 must be selected among the white elements of Table 6. If $G_1 = 2P_1$ and $G_3 = 2P_2$, the set of white elements is $\mathcal{C}_0 \cup (\mathcal{C}_0 + P_1) \cup (\mathcal{C}_0 + P_2) \cup (\mathcal{C}_0 + P_1 + P_2) \setminus \Lambda_2$.

c_0	$\begin{bmatrix} 0 \\ 0 \\ 0 \end{bmatrix}$	$\begin{bmatrix} 0 \\ 0 \\ 2 \end{bmatrix}$	$\begin{bmatrix} 0 \\ 2 \\ 0 \end{bmatrix}$	$\begin{bmatrix} 0 \\ 2 \\ 2 \end{bmatrix}$	$\begin{bmatrix} 2 \\ 0 \\ 0 \end{bmatrix}$	$\begin{bmatrix} 2 \\ 0 \\ 2 \end{bmatrix}$	$\begin{bmatrix} 2 \\ 2 \\ 0 \end{bmatrix}$	$\begin{bmatrix} 2 \\ 2 \\ 2 \end{bmatrix}$
$c \begin{bmatrix} 0 \\ 1 \\ 1 \end{bmatrix}$	$\begin{bmatrix} 0 \\ 1 \\ 1 \end{bmatrix}$	$\begin{bmatrix} 0 \\ 1 \\ 3 \end{bmatrix}$	$\begin{bmatrix} 0 \\ 3 \\ 1 \end{bmatrix}$	$\begin{bmatrix} 0 \\ 3 \\ 3 \end{bmatrix}$	$\begin{bmatrix} 2 \\ 1 \\ 1 \end{bmatrix}$	$\begin{bmatrix} 2 \\ 1 \\ 3 \end{bmatrix}$	$\begin{bmatrix} 2 \\ 3 \\ 1 \end{bmatrix}$	$\begin{bmatrix} 2 \\ 3 \\ 3 \end{bmatrix}$
$c \begin{bmatrix} 0 \\ 0 \\ 1 \end{bmatrix}$	$\begin{bmatrix} 0 \\ 0 \\ 1 \end{bmatrix}$	$\begin{bmatrix} 0 \\ 0 \\ 3 \end{bmatrix}$	$\begin{bmatrix} 0 \\ 2 \\ 1 \end{bmatrix}$	$\begin{bmatrix} 0 \\ 2 \\ 3 \end{bmatrix}$	$\begin{bmatrix} 2 \\ 0 \\ 1 \end{bmatrix}$	$\begin{bmatrix} 2 \\ 0 \\ 3 \end{bmatrix}$	$\begin{bmatrix} 2 \\ 2 \\ 1 \end{bmatrix}$	$\begin{bmatrix} 2 \\ 2 \\ 3 \end{bmatrix}$
$c \begin{bmatrix} 0 \\ 1 \\ 0 \end{bmatrix}$	$\begin{bmatrix} 0 \\ 1 \\ 0 \end{bmatrix}$	$\begin{bmatrix} 0 \\ 1 \\ 2 \end{bmatrix}$	$\begin{bmatrix} 0 \\ 3 \\ 2 \end{bmatrix}$	$\begin{bmatrix} 0 \\ 3 \\ 2 \end{bmatrix}$	$\begin{bmatrix} 2 \\ 1 \\ 0 \end{bmatrix}$	$\begin{bmatrix} 2 \\ 1 \\ 2 \end{bmatrix}$	$\begin{bmatrix} 2 \\ 3 \\ 0 \end{bmatrix}$	$\begin{bmatrix} 2 \\ 3 \\ 2 \end{bmatrix}$

Table 6. Selection of G_3 of \mathbf{G}

Now, we select $G_4 = \begin{bmatrix} 2 \\ 2 \\ 3 \end{bmatrix}$. A new subgroup is created, as shown by the colored elements in Table 7.

c_0	$\begin{bmatrix} 0 \\ 0 \\ 0 \end{bmatrix}$	$\begin{bmatrix} 0 \\ 0 \\ 2 \end{bmatrix}$	$\begin{bmatrix} 0 \\ 2 \\ 0 \end{bmatrix}$	$\begin{bmatrix} 0 \\ 2 \\ 2 \end{bmatrix}$	$\begin{bmatrix} 2 \\ 0 \\ 0 \end{bmatrix}$	$\begin{bmatrix} 2 \\ 0 \\ 2 \end{bmatrix}$	$\begin{bmatrix} 2 \\ 2 \\ 0 \end{bmatrix}$	$\begin{bmatrix} 2 \\ 2 \\ 2 \end{bmatrix}$
$c \begin{bmatrix} 0 \\ 1 \\ 1 \end{bmatrix}$	$\begin{bmatrix} 0 \\ 1 \\ 1 \end{bmatrix}$	$\begin{bmatrix} 0 \\ 1 \\ 3 \end{bmatrix}$	$\begin{bmatrix} 0 \\ 3 \\ 1 \end{bmatrix}$	$\begin{bmatrix} 0 \\ 3 \\ 3 \end{bmatrix}$	$\begin{bmatrix} 2 \\ 1 \\ 1 \end{bmatrix}$	$\begin{bmatrix} 2 \\ 1 \\ 3 \end{bmatrix}$	$\begin{bmatrix} 2 \\ 3 \\ 1 \end{bmatrix}$	$\begin{bmatrix} 2 \\ 3 \\ 3 \end{bmatrix}$
$c \begin{bmatrix} 0 \\ 0 \\ 1 \end{bmatrix}$	$\begin{bmatrix} 0 \\ 0 \\ 1 \end{bmatrix}$	$\begin{bmatrix} 0 \\ 0 \\ 3 \end{bmatrix}$	$\begin{bmatrix} 0 \\ 2 \\ 1 \end{bmatrix}$	$\begin{bmatrix} 0 \\ 2 \\ 3 \end{bmatrix}$	$\begin{bmatrix} 2 \\ 0 \\ 1 \end{bmatrix}$	$\begin{bmatrix} 2 \\ 0 \\ 3 \end{bmatrix}$	$\begin{bmatrix} 2 \\ 2 \\ 1 \end{bmatrix}$	$\begin{bmatrix} 2 \\ 2 \\ 3 \end{bmatrix}$
$c \begin{bmatrix} 0 \\ 1 \\ 0 \end{bmatrix}$	$\begin{bmatrix} 0 \\ 1 \\ 0 \end{bmatrix}$	$\begin{bmatrix} 0 \\ 1 \\ 2 \end{bmatrix}$	$\begin{bmatrix} 0 \\ 3 \\ 2 \end{bmatrix}$	$\begin{bmatrix} 0 \\ 3 \\ 2 \end{bmatrix}$	$\begin{bmatrix} 2 \\ 1 \\ 0 \end{bmatrix}$	$\begin{bmatrix} 2 \\ 1 \\ 2 \end{bmatrix}$	$\begin{bmatrix} 2 \\ 3 \\ 0 \end{bmatrix}$	$\begin{bmatrix} 2 \\ 3 \\ 2 \end{bmatrix}$

Table 7. Selection of G_4 of \mathbf{G}

If G_5 is selected among to the white elements of Table 7, for example $G_5 = \begin{bmatrix} 2 \\ 2 \end{bmatrix}$, C_0 is totally generated. Hence, a new set to select the last element, which is represented by the white elements of Table 8 is created.

c_0	$\begin{bmatrix} 0 \\ 0 \\ 0 \end{bmatrix}$	$\begin{bmatrix} 0 \\ 0 \\ 2 \end{bmatrix}$	$\begin{bmatrix} 0 \\ 2 \\ 0 \end{bmatrix}$	$\begin{bmatrix} 0 \\ 2 \\ 2 \end{bmatrix}$	$\begin{bmatrix} 2 \\ 0 \\ 0 \end{bmatrix}$	$\begin{bmatrix} 2 \\ 0 \\ 2 \end{bmatrix}$	$\begin{bmatrix} 2 \\ 2 \\ 0 \end{bmatrix}$	$\begin{bmatrix} 2 \\ 2 \\ 2 \end{bmatrix}$
$c \begin{bmatrix} 0 \\ 1 \\ 1 \end{bmatrix}$	$\begin{bmatrix} 0 \\ 1 \\ 1 \end{bmatrix}$	$\begin{bmatrix} 0 \\ 1 \\ 3 \end{bmatrix}$	$\begin{bmatrix} 0 \\ 3 \\ 1 \end{bmatrix}$	$\begin{bmatrix} 0 \\ 3 \\ 3 \end{bmatrix}$	$\begin{bmatrix} 2 \\ 1 \\ 1 \end{bmatrix}$	$\begin{bmatrix} 2 \\ 1 \\ 3 \end{bmatrix}$	$\begin{bmatrix} 2 \\ 3 \\ 1 \end{bmatrix}$	$\begin{bmatrix} 2 \\ 3 \\ 3 \end{bmatrix}$
$c \begin{bmatrix} 0 \\ 0 \\ 1 \end{bmatrix}$	$\begin{bmatrix} 0 \\ 0 \\ 1 \end{bmatrix}$	$\begin{bmatrix} 0 \\ 0 \\ 3 \end{bmatrix}$	$\begin{bmatrix} 0 \\ 2 \\ 1 \end{bmatrix}$	$\begin{bmatrix} 0 \\ 2 \\ 3 \end{bmatrix}$	$\begin{bmatrix} 2 \\ 0 \\ 1 \end{bmatrix}$	$\begin{bmatrix} 2 \\ 0 \\ 3 \end{bmatrix}$	$\begin{bmatrix} 2 \\ 2 \\ 1 \end{bmatrix}$	$\begin{bmatrix} 2 \\ 2 \\ 3 \end{bmatrix}$
$c \begin{bmatrix} 0 \\ 1 \\ 0 \end{bmatrix}$	$\begin{bmatrix} 0 \\ 1 \\ 0 \end{bmatrix}$	$\begin{bmatrix} 0 \\ 1 \\ 2 \end{bmatrix}$	$\begin{bmatrix} 0 \\ 3 \\ 0 \end{bmatrix}$	$\begin{bmatrix} 0 \\ 3 \\ 2 \end{bmatrix}$	$\begin{bmatrix} 2 \\ 1 \\ 0 \end{bmatrix}$	$\begin{bmatrix} 2 \\ 1 \\ 2 \end{bmatrix}$	$\begin{bmatrix} 2 \\ 3 \\ 0 \end{bmatrix}$	$\begin{bmatrix} 2 \\ 3 \\ 2 \end{bmatrix}$
$c \begin{bmatrix} 1 \\ 0 \\ 0 \end{bmatrix}$	$\begin{bmatrix} 1 \\ 0 \\ 0 \end{bmatrix}$	$\begin{bmatrix} 1 \\ 0 \\ 2 \end{bmatrix}$	$\begin{bmatrix} 1 \\ 2 \\ 0 \end{bmatrix}$	$\begin{bmatrix} 1 \\ 2 \\ 2 \end{bmatrix}$	$\begin{bmatrix} 3 \\ 0 \\ 0 \end{bmatrix}$	$\begin{bmatrix} 3 \\ 0 \\ 2 \end{bmatrix}$	$\begin{bmatrix} 3 \\ 2 \\ 0 \end{bmatrix}$	$\begin{bmatrix} 3 \\ 2 \\ 2 \end{bmatrix}$
$c \begin{bmatrix} 1 \\ 0 \\ 1 \end{bmatrix}$	$\begin{bmatrix} 1 \\ 0 \\ 1 \end{bmatrix}$	$\begin{bmatrix} 1 \\ 0 \\ 3 \end{bmatrix}$	$\begin{bmatrix} 1 \\ 2 \\ 1 \end{bmatrix}$	$\begin{bmatrix} 1 \\ 2 \\ 3 \end{bmatrix}$	$\begin{bmatrix} 3 \\ 0 \\ 1 \end{bmatrix}$	$\begin{bmatrix} 3 \\ 0 \\ 3 \end{bmatrix}$	$\begin{bmatrix} 3 \\ 2 \\ 1 \end{bmatrix}$	$\begin{bmatrix} 3 \\ 2 \\ 3 \end{bmatrix}$
$c \begin{bmatrix} 1 \\ 1 \\ 0 \end{bmatrix}$	$\begin{bmatrix} 1 \\ 1 \\ 0 \end{bmatrix}$	$\begin{bmatrix} 1 \\ 1 \\ 2 \end{bmatrix}$	$\begin{bmatrix} 1 \\ 3 \\ 0 \end{bmatrix}$	$\begin{bmatrix} 1 \\ 3 \\ 2 \end{bmatrix}$	$\begin{bmatrix} 3 \\ 1 \\ 0 \end{bmatrix}$	$\begin{bmatrix} 3 \\ 1 \\ 2 \end{bmatrix}$	$\begin{bmatrix} 3 \\ 3 \\ 0 \end{bmatrix}$	$\begin{bmatrix} 3 \\ 3 \\ 2 \end{bmatrix}$
$c \begin{bmatrix} 1 \\ 1 \\ 1 \end{bmatrix}$	$\begin{bmatrix} 1 \\ 1 \\ 1 \end{bmatrix}$	$\begin{bmatrix} 1 \\ 1 \\ 3 \end{bmatrix}$	$\begin{bmatrix} 1 \\ 3 \\ 1 \end{bmatrix}$	$\begin{bmatrix} 1 \\ 3 \\ 3 \end{bmatrix}$	$\begin{bmatrix} 3 \\ 1 \\ 1 \end{bmatrix}$	$\begin{bmatrix} 3 \\ 1 \\ 3 \end{bmatrix}$	$\begin{bmatrix} 3 \\ 3 \\ 1 \end{bmatrix}$	$\begin{bmatrix} 3 \\ 3 \\ 3 \end{bmatrix}$

Table 8. Selection of G_5 of \mathbf{G}

If G_6 is chosen among belong to the white elements of Table 8, the totality of $\mathbb{Z}_{2^n}^{nT}$ is generated. For example, we can select $G_6 = \begin{bmatrix} 3 \\ 3 \\ 1 \end{bmatrix}$. The created code is a minimal length code with the generator matrix

$$\mathbf{G} = \begin{bmatrix} 0 & 2 & 0 & 2 & 2 & 2 & 3 \\ 2 & 1 & 0 & 2 & 2 & 2 & 3 \\ 2 & 3 & 2 & 3 & 2 & 2 & 1 \end{bmatrix}. \tag{31}$$

As stated by the property 5, if an additional column is added to the generator matrix, the resulting code is also fully balanced. The number of occurrences of each MIMO symbol is given by $2^{L_r - L_{min}}$, where $L_r - L_{min}$ is the number of additional columns. Thus, the columns $G_7 = \begin{bmatrix} 0 \\ 2 \\ 2 \end{bmatrix}$ and $G_8 = \begin{bmatrix} 2 \\ 1 \\ 1 \end{bmatrix}$ are added to the generator matrix. We obtain

$$\mathbf{G} = \begin{bmatrix} 0 & 2 & 0 & 2 & 2 & 3 & 0 & 2 \\ 2 & 1 & 0 & 2 & 2 & 3 & 2 & 1 \\ 2 & 3 & 2 & 3 & 2 & 1 & 2 & 1 \end{bmatrix}. \tag{32}$$

Table 9 shows the code proposed by Chen et al. (2002b) and the new generated code which are both fully balanced. The minimal rank and the minimal trace of each code are also given. The new code has a better rank and trace than the corresponding Chen’s code. The FER and bit error rate (BER) of these two STTCs are presented respectively in Figs. 2 and 3. For the simulation, the channel fading coefficients are independent samples of a complex Gaussian process with zero mean and variance 0.5 per dimension. These channel coefficients are assumed to be known by the decoder. Each codeword consists of 130 MIMO symbols. For the simulation, 2 and 4 receive antennas are considered. The decoding is performed by the Viterbi’s algorithm. We remark that the new code slightly outperforms the Chen’s code.

Name	G	Rank	d_{\min}^2
Chen et al. (2002b)	$\begin{bmatrix} 0 & 2 & 3 & 2 & 3 & 0 & 3 & 2 \\ 2 & 2 & 1 & 2 & 3 & 0 & 2 & 0 \\ 2 & 0 & 0 & 2 & 2 & 3 & 1 & 1 \end{bmatrix}$	2	28
New	$\begin{bmatrix} 0 & 2 & 0 & 2 & 2 & 3 & 0 & 2 \\ 2 & 1 & 0 & 2 & 2 & 3 & 2 & 1 \\ 2 & 3 & 2 & 3 & 2 & 1 & 2 & 1 \end{bmatrix}$	3	32

Table 9. 64 states 4-PSK STTCs with 3 transmit antennas

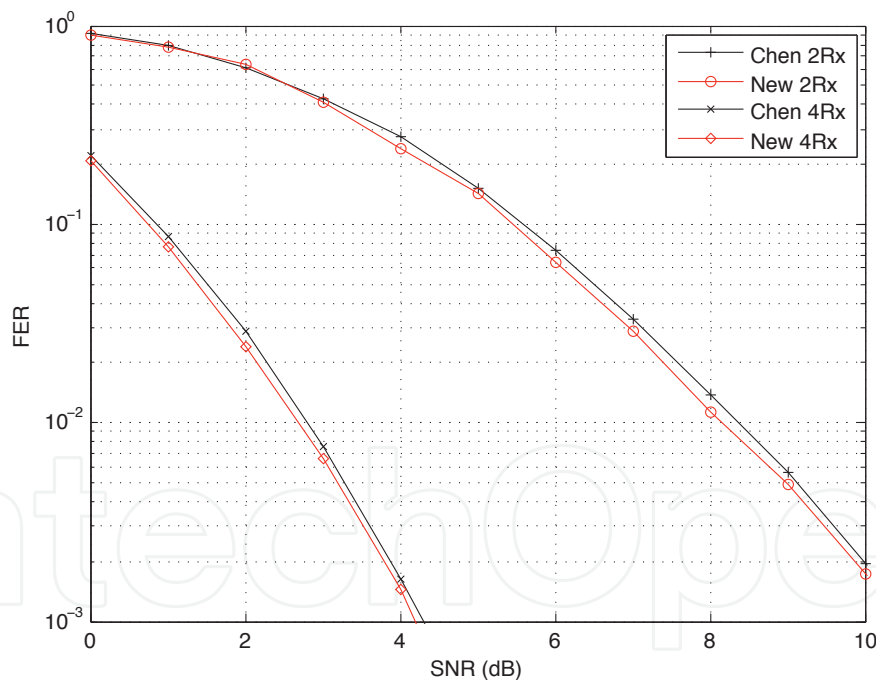

Fig. 2. FER of 64 states 4-PSK STTCs with 3 transmit antennas

5.4 Example of the generation of a balanced 8 states 8-PSK STTC with 4 transmit antennas

This section presents a design of balanced 8 states 8-PSK STTCs with 4 transmit antennas. The generator matrix is

$$G = [G_1 G_2 G_3 | G_4 G_5 G_6], \tag{33}$$

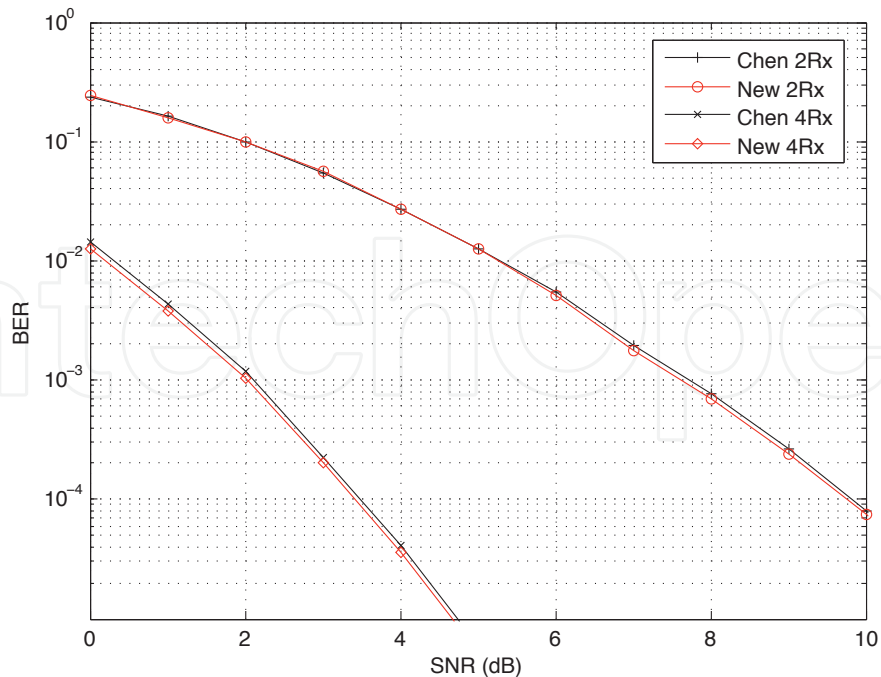

Fig. 3. BER of 64 states 4-PSK STTCs with 3 transmit antennas

with $G_i = [G_i^1 G_i^2 G_i^3 G_i^4]^T \in \mathbb{Z}_8^4$ for $i = \overline{1,6}$. This code can not be fully balanced but just balanced. In fact, a fully balanced 8-PSK STTC with 4 transmit antennas must have 12 columns to be fully balanced (c.f. property 4).

The group \mathbb{Z}_8^4 is divided into 3 sets $\mathcal{E}_0, \mathcal{E}_1$ and \mathcal{E}_2 . Each set \mathcal{E}_i is the union of several cosets. Each coset included in \mathcal{E}_i is relative to one vector of \mathcal{E}_{i-1} with $i=\{1,2\}$.

In general, the first no null column of the generator matrix must belong to

$$\mathcal{C}_0 = 2^{n-1} \mathbb{Z}_2^{n_T}. \tag{34}$$

Thereby, for the design of 8 states 8-PSK STTCs with 4 transmit antennas, $G_1 \in 2\mathbb{Z}_2^4$ for example $G_1 = \begin{bmatrix} 4 \\ 0 \\ 4 \\ 4 \end{bmatrix} = 2P_1$, with $P_1 = \begin{bmatrix} 2 \\ 0 \\ 2 \\ 2 \end{bmatrix}$. The first generated subgroup is $\Lambda_1 = \{0, G_1\}$.

The next column of \mathbf{G} must belong to

$$\mathcal{S}_2 = (\mathcal{C}_0 \cup \mathcal{C}_{P_1}) \setminus \Lambda_1, \tag{35}$$

where $\mathcal{C}_{P_1} \subset \mathcal{E}_1$ is the coset relative to G_1 . The second column of \mathbf{G} can be $G_2 = \begin{bmatrix} 2 \\ 4 \\ 2 \\ 2 \end{bmatrix}$. The subgroup generated by the first two columns is

$$\Lambda_2 = \{0, G_1, G_2, G_1 + G_2\} \tag{36}$$

$$= \left\{ \begin{bmatrix} 0 \\ 0 \\ 0 \\ 0 \end{bmatrix}, \begin{bmatrix} 4 \\ 0 \\ 4 \\ 4 \end{bmatrix}, \begin{bmatrix} 2 \\ 4 \\ 2 \\ 2 \end{bmatrix}, \begin{bmatrix} 6 \\ 4 \\ 6 \\ 6 \end{bmatrix} \right\}, \tag{37}$$

with $G_1 + G_2 = -G_2$. As G_2 and $-G_2 \in \mathcal{E}_1$, the next column must belong to the set

$$\mathcal{S}_3 = (\mathcal{C}_0 \cup \mathcal{C}_{P_1} \cup \mathcal{C}_{P_2} \cup \mathcal{C}_{P_1+P_2}) \setminus \Lambda_2, \tag{38}$$

with $G_3 = \begin{bmatrix} 7 \\ 6 \\ 3 \\ 3 \end{bmatrix} \in \mathcal{C}_{P_1+P_2}$. The next generated subgroup is

$$\Lambda_3 = \Lambda_2 \cup (\Lambda_2 + G_3) = \left\{ \begin{bmatrix} 0 \\ 0 \\ 0 \\ 0 \end{bmatrix}, \begin{bmatrix} 4 \\ 0 \\ 4 \\ 4 \end{bmatrix}, \begin{bmatrix} 2 \\ 4 \\ 2 \\ 2 \end{bmatrix}, \begin{bmatrix} 6 \\ 4 \\ 6 \\ 6 \end{bmatrix}, \begin{bmatrix} 7 \\ 6 \\ 3 \\ 3 \end{bmatrix}, \begin{bmatrix} 3 \\ 6 \\ 7 \\ 7 \end{bmatrix}, \begin{bmatrix} 1 \\ 2 \\ 5 \\ 5 \end{bmatrix}, \begin{bmatrix} 5 \\ 2 \\ 1 \\ 1 \end{bmatrix} \right\}. \tag{39}$$

The new generated elements $\Lambda_3 \setminus \Lambda_2$ belong to \mathcal{E}_2 . Since no coset is relative to the elements of \mathcal{E}_2 , the set using to select G_4 is

$$\mathcal{S}_4 = \mathcal{S}_3 \setminus \Lambda_3 = \left(\mathcal{C}_0 \cup \mathcal{C}_{P_1} \cup \mathcal{C}_{P_2} \cup \mathcal{C}_{(P_1+P_2)} \right) \setminus \Lambda_3, \tag{40}$$

It is possible to select $G_4 = \begin{bmatrix} 0 \\ 4 \\ 4 \\ 4 \end{bmatrix}$. The new generated subgroup is

$$\Lambda_4 = \Lambda_3 \cup (\Lambda_3 + G_4) \tag{41}$$

$$= \left\{ \begin{bmatrix} 0 \\ 0 \\ 0 \\ 0 \end{bmatrix}, \begin{bmatrix} 4 \\ 0 \\ 4 \\ 4 \end{bmatrix}, \begin{bmatrix} 2 \\ 4 \\ 2 \\ 2 \end{bmatrix}, \begin{bmatrix} 6 \\ 4 \\ 6 \\ 6 \end{bmatrix}, \begin{bmatrix} 7 \\ 6 \\ 3 \\ 3 \end{bmatrix}, \begin{bmatrix} 3 \\ 6 \\ 7 \\ 7 \end{bmatrix}, \begin{bmatrix} 1 \\ 2 \\ 5 \\ 5 \end{bmatrix}, \begin{bmatrix} 5 \\ 2 \\ 1 \\ 1 \end{bmatrix}, \begin{bmatrix} 0 \\ 4 \\ 4 \\ 4 \end{bmatrix}, \begin{bmatrix} 4 \\ 4 \\ 0 \\ 4 \end{bmatrix}, \begin{bmatrix} 2 \\ 6 \\ 2 \\ 2 \end{bmatrix}, \begin{bmatrix} 6 \\ 6 \\ 2 \\ 6 \end{bmatrix}, \begin{bmatrix} 7 \\ 2 \\ 7 \\ 7 \end{bmatrix}, \begin{bmatrix} 3 \\ 2 \\ 3 \\ 7 \end{bmatrix}, \begin{bmatrix} 1 \\ 6 \\ 1 \\ 5 \end{bmatrix}, \begin{bmatrix} 5 \\ 6 \\ 5 \\ 1 \end{bmatrix} \right\}. \tag{42}$$

The 5th column of \mathbf{G} must be selected either in \mathcal{C}_0^* or in a coset relative to an element of the set

$$\Lambda_4 \cap (\mathcal{E}_0^* \cup \mathcal{E}_1) = \left\{ \begin{bmatrix} 4 \\ 4 \\ 4 \\ 4 \end{bmatrix}, \begin{bmatrix} 2 \\ 4 \\ 2 \\ 2 \end{bmatrix}, \begin{bmatrix} 6 \\ 4 \\ 6 \\ 6 \end{bmatrix}, \begin{bmatrix} 0 \\ 4 \\ 4 \\ 0 \end{bmatrix}, \begin{bmatrix} 4 \\ 4 \\ 4 \\ 4 \end{bmatrix}, \begin{bmatrix} 2 \\ 6 \\ 2 \\ 2 \end{bmatrix}, \begin{bmatrix} 6 \\ 6 \\ 2 \\ 6 \end{bmatrix} \right\}. \tag{43}$$

Thus, it is possible to select $G_5 = \begin{bmatrix} 0 \\ 6 \\ 6 \\ 4 \end{bmatrix} \in \mathcal{C}_{\begin{bmatrix} 0 \\ 2 \\ 2 \\ 0 \end{bmatrix}}$. The new generated subgroup is

$$\Lambda_5 = \Lambda_4 \cup (\Lambda_4 + G_5) \tag{44}$$

$$= \left\{ \begin{bmatrix} 0 \\ 0 \\ 0 \\ 0 \end{bmatrix}, \begin{bmatrix} 4 \\ 0 \\ 4 \\ 4 \end{bmatrix}, \begin{bmatrix} 2 \\ 4 \\ 2 \\ 2 \end{bmatrix}, \begin{bmatrix} 6 \\ 4 \\ 6 \\ 6 \end{bmatrix}, \begin{bmatrix} 7 \\ 6 \\ 3 \\ 3 \end{bmatrix}, \begin{bmatrix} 3 \\ 6 \\ 7 \\ 7 \end{bmatrix}, \begin{bmatrix} 1 \\ 2 \\ 5 \\ 5 \end{bmatrix}, \begin{bmatrix} 5 \\ 2 \\ 1 \\ 1 \end{bmatrix}, \begin{bmatrix} 0 \\ 4 \\ 4 \\ 4 \end{bmatrix}, \begin{bmatrix} 4 \\ 4 \\ 0 \\ 4 \end{bmatrix}, \begin{bmatrix} 2 \\ 6 \\ 2 \\ 2 \end{bmatrix}, \begin{bmatrix} 6 \\ 6 \\ 2 \\ 6 \end{bmatrix}, \begin{bmatrix} 7 \\ 2 \\ 7 \\ 7 \end{bmatrix}, \begin{bmatrix} 3 \\ 2 \\ 3 \\ 7 \end{bmatrix}, \begin{bmatrix} 1 \\ 6 \\ 1 \\ 5 \end{bmatrix}, \begin{bmatrix} 5 \\ 6 \\ 5 \\ 1 \end{bmatrix}, \begin{bmatrix} 0 \\ 6 \\ 6 \\ 4 \end{bmatrix}, \begin{bmatrix} 4 \\ 6 \\ 2 \\ 0 \end{bmatrix}, \begin{bmatrix} 2 \\ 2 \\ 0 \\ 6 \end{bmatrix}, \begin{bmatrix} 6 \\ 2 \\ 4 \\ 2 \end{bmatrix}, \begin{bmatrix} 7 \\ 4 \\ 1 \\ 7 \end{bmatrix}, \begin{bmatrix} 3 \\ 4 \\ 5 \\ 3 \end{bmatrix}, \begin{bmatrix} 1 \\ 0 \\ 3 \\ 3 \end{bmatrix}, \begin{bmatrix} 5 \\ 0 \\ 7 \\ 5 \end{bmatrix}, \begin{bmatrix} 0 \\ 2 \\ 2 \\ 4 \end{bmatrix}, \begin{bmatrix} 4 \\ 2 \\ 2 \\ 0 \end{bmatrix}, \begin{bmatrix} 2 \\ 6 \\ 4 \\ 6 \end{bmatrix}, \begin{bmatrix} 6 \\ 6 \\ 0 \\ 2 \end{bmatrix}, \begin{bmatrix} 7 \\ 0 \\ 5 \\ 7 \end{bmatrix}, \begin{bmatrix} 3 \\ 0 \\ 1 \\ 3 \end{bmatrix}, \begin{bmatrix} 1 \\ 4 \\ 7 \\ 1 \end{bmatrix}, \begin{bmatrix} 5 \\ 4 \\ 3 \\ 5 \end{bmatrix} \right\}. \tag{45}$$

To generate a balanced STTC, the last column of the generator matrix must be selected anywhere in $\mathbb{Z}_{2^n}^{n_T}$. Thus, G_6 can be $\begin{bmatrix} 4 \\ 3 \\ 0 \\ 2 \end{bmatrix}$. The generator matrix is

$$\mathbf{G} = \left[\begin{array}{ccc|ccc} 4 & 2 & 7 & 0 & 0 & 4 \\ 0 & 4 & 6 & 4 & 6 & 3 \\ 4 & 2 & 3 & 4 & 6 & 0 \\ 4 & 2 & 3 & 0 & 4 & 2 \end{array} \right]. \tag{46}$$

After the selection of the last column G_6 , the generated set Λ_6 is not a subgroup. Table 10 shows the code 8 states 8-PSK STTC with 4 transmit antennas presented by Chen et al. (2002a) and the new generated code which are both balanced. The minimal rank and the minimal trace $d_{E, \min}^2$ of each code are also presented. The new code has a better trace than the corresponding Chen's code. The FER and BER of these two STTCs with 2 and 4 receive antennas are presented respectively in Figs. 4 and 5. We remark that the new code slightly outperforms the Chen's code.

Code	G	Rank	$d_{E, \min}^2$
Chen et al. (2002a)	$\begin{bmatrix} 2 & 4 & 0 & 3 & 2 & 4 \\ 1 & 6 & 4 & 4 & 0 & 0 \\ 3 & 2 & 4 & 0 & 4 & 2 \\ 7 & 2 & 4 & 5 & 4 & 0 \end{bmatrix}$	2	16.58
New	$\begin{bmatrix} 4 & 2 & 7 & 0 & 0 & 4 \\ 0 & 4 & 6 & 4 & 6 & 3 \\ 4 & 2 & 3 & 4 & 6 & 0 \\ 4 & 2 & 3 & 0 & 4 & 2 \end{bmatrix}$	2	17.17

Table 10. 8 states 8-PSK STTCs with 4 transmit antennas

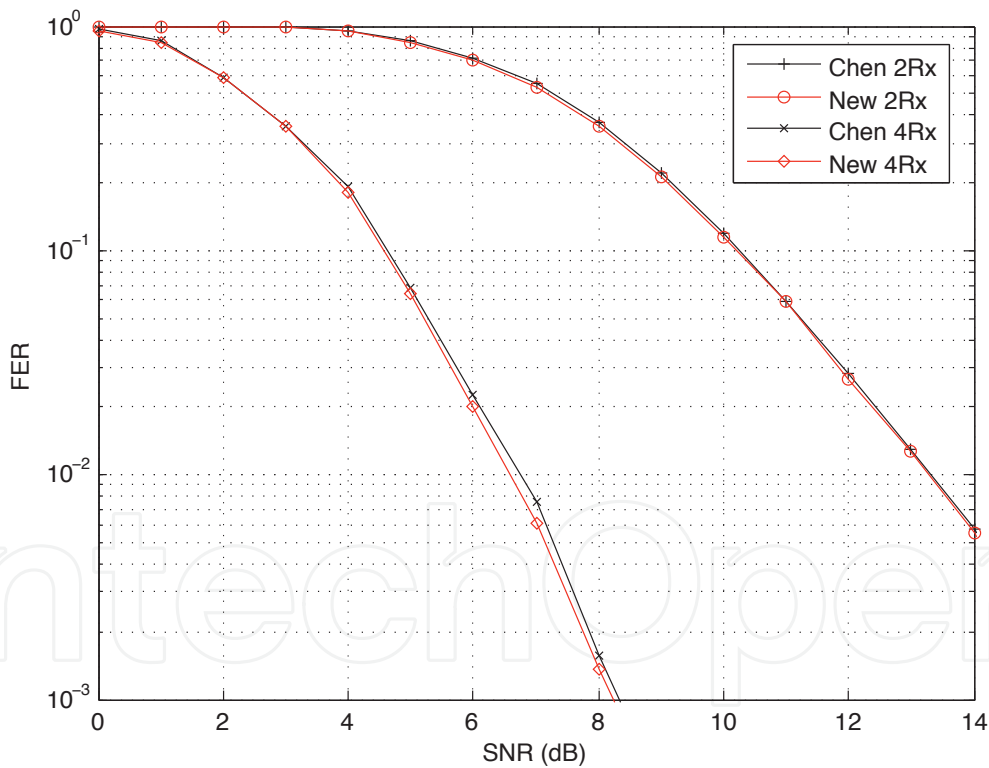

Fig. 4. FER of 8 states 8-PSK STTCs with 4 transmit antennas

6. Other new 4-PSK STTCs

Via this new method, other STTCs have been generated. Example of balanced 4-PSK STTCs are presented in Table 11. The performance of these STTCs is shown in Fig. 6. The codes noted by 'B' are balanced, those by 'FB' are fully balanced and those noted by 'NB' are not balanced.

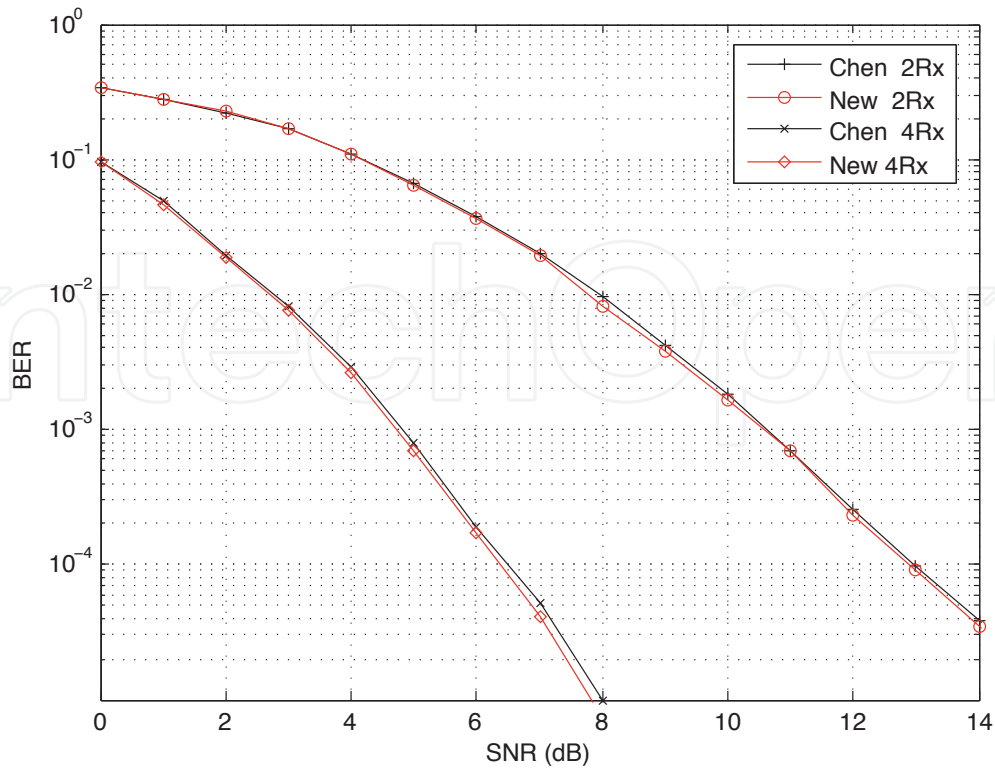

Fig. 5. BER of 8 states 8-PSK STTCs with 4 transmit antennas

n_T	States	Code	G		$d_{E, \min}^2$
3	32	Chen <i>et al.</i> Chen et al. (2002a)	$\begin{bmatrix} 0 & 2 & 2 & 1 & 1 & 2 & 0 & 2 \\ 2 & 2 & 3 & 2 & 2 & 3 & 0 & 0 \\ 2 & 0 & 2 & 2 & 2 & 1 & 0 & 0 \end{bmatrix}$	FB	24
		New	$\begin{bmatrix} 2 & 1 & 2 & 3 & 2 & 3 & 0 & 2 \\ 2 & 3 & 0 & 2 & 2 & 1 & 0 & 0 \\ 2 & 1 & 2 & 1 & 0 & 0 & 0 & 2 \end{bmatrix}$	FB	26
4	32	Chen <i>et al.</i> Chen et al. (2002a)	$\begin{bmatrix} 0 & 2 & 2 & 1 & 1 & 2 & 0 & 2 \\ 2 & 2 & 3 & 2 & 2 & 3 & 0 & 0 \\ 2 & 0 & 3 & 2 & 2 & 1 & 0 & 0 \\ 2 & 1 & 2 & 0 & 1 & 0 & 0 & 2 \end{bmatrix}$	NB	36
		New	$\begin{bmatrix} 2 & 3 & 2 & 1 & 2 & 1 & 0 & 2 \\ 0 & 2 & 2 & 1 & 2 & 3 & 0 & 3 \\ 2 & 3 & 2 & 3 & 0 & 0 & 0 & 2 \\ 2 & 1 & 0 & 2 & 2 & 1 & 0 & 0 \end{bmatrix}$	B	36
	64	Chen <i>et al.</i> Chen et al. (2002a)	$\begin{bmatrix} 0 & 2 & 3 & 2 & 0 & 3 & 2 \\ 2 & 2 & 1 & 2 & 3 & 0 & 2 & 0 \\ 2 & 0 & 0 & 2 & 2 & 3 & 1 & 1 \\ 1 & 2 & 2 & 0 & 2 & 1 & 3 & 3 \end{bmatrix}$	NB	38
		New	$\begin{bmatrix} 1 & 2 & 2 & 0 & 3 & 2 & 1 & 2 \\ 3 & 2 & 3 & 2 & 2 & 0 & 3 & 2 \\ 2 & 0 & 1 & 2 & 3 & 2 & 3 & 2 \\ 1 & 2 & 2 & 0 & 2 & 0 & 2 & 0 \end{bmatrix}$	B	40

Table 11. 4-PSK STTCs

7. Conclusion

The use of STTCs is an efficient solution to improve the performance of wireless MIMO systems. However, difficulties arise in terms of computational time to find the best codes

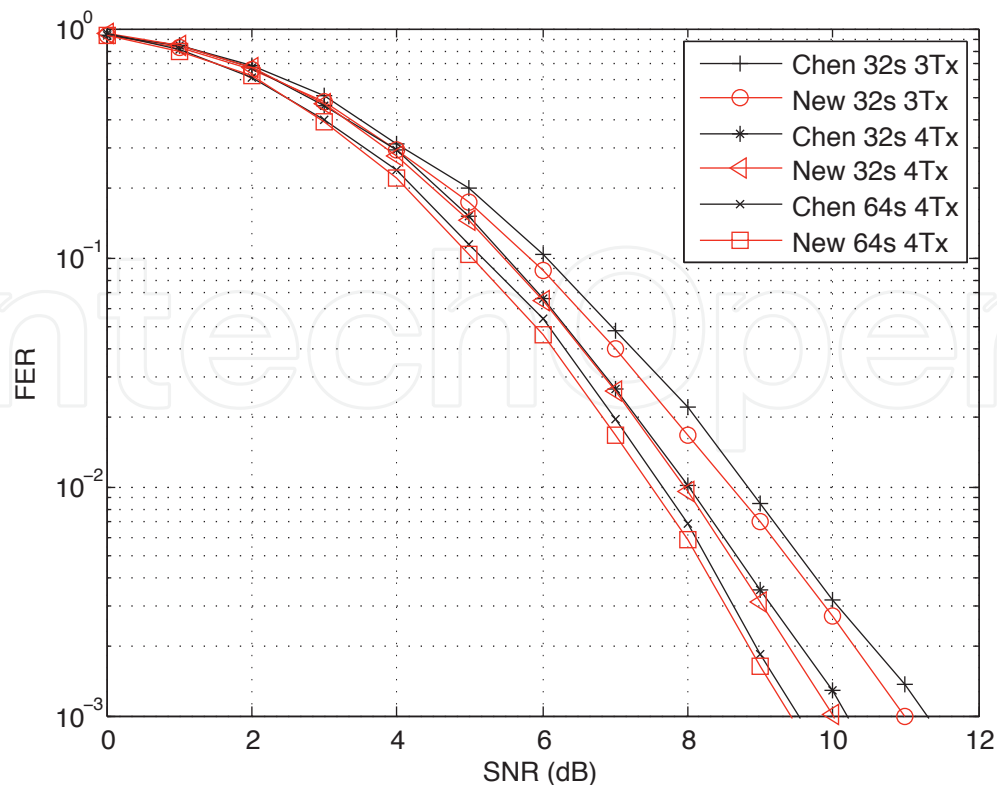

Fig. 6. FER of 4-PSK STTCs with 2 receive antennas

especially for a great number of transmit antennas. In order to reduce the search-time, this chapter presents a new and simple method to design balanced STTCs. A balanced STTC is a STTC which generates the MIMO symbols with the same probability when the binary input symbols are equiprobable. Each best STTC belongs to this class. Thereby, it is sufficient to generate only the balanced STTCs to find those with the best performance. Consequently, the search-time is considerably reduced.

The new method proposed in this chapter is simpler than the first method proposed by Ngo et al. (2008; 2007) and used only for 4-PSK modulation. Besides, the new method is given for 2^n -PSK STTCs and n_T transmit antennas. It is based on the generation of the subgroup of $\mathbb{Z}_{2^n}^{n_T}$ which determines a partition of $\mathbb{Z}_{2^n}^{n_T}$ in cosets.

Furthermore, several new 4-PSK and 8-PSK balanced STTCs have been proposed. These new STTCs outperform slightly the best corresponding published codes.

8. References

- Abdool-Rassool, B., Nakhai, M., Heliot, F., Revelly, L. & Aghvami, H. (2004). Search for space-time trellis codes: novel codes for rayleigh fading channels, *Communications, IEE Proceedings-* 151(1): 25 – 31.
- Chen, Z., Vucetic, B., Yuan, J. & Lo, K. L. (2002a). Space-time trellis codes for 4-PSK with three and four transmit antennas in quasi-static flat fading channels, *Communications Letters, IEEE* 6(2): 67 – 69.
- Chen, Z., Vucetic, B., Yuan, J. & Lo, K. L. (2002b). Space-time trellis codes with two, three and four transmit antennas in quasi-static flat fading channels, *Communications, 2002. ICC 2002. IEEE International Conference on*, Vol. 3, pp. 1589 – 1595 vol.3.

- Chen, Z., Yuan, J. & Vucetic, B. (2001). Improved space-time trellis coded modulation scheme on slow rayleigh fading channels, *Electronics Letters* 37(7): 440–441.
- Coleman, J. (2002). Coset decomposition in lattices yields sample-block number systems, *Proc. IEEE ISCAS 2002*, Vol. 2, pp. 688–691 vol.2.
- Forney, G.D., J. (1988). Coset codes. I. Introduction and geometrical classification, *IEEE Transactions on Information Theory* 34(5): 1123–1151.
- Hong, Y. & Guillen i Fabregas, A. (2007). New space-time trellis codes for two-antenna quasi-static channels, *Vehicular Technology, IEEE Transactions on* 56(6): 3581–3587.
- Ionescu, D. (1999). New results on space-time code design criteria, *Wireless Communications and Networking Conference, 1999. WCNC. 1999 IEEE*, pp. 684–687 vol.2.
- Liao, C. & Prabhu, V. (2005). Improved code design criteria for space-time codes over quasi-static flat fading channels, *Signal Processing Advances in Wireless Communications, 2005 IEEE 6th Workshop on*, pp. 7–11.
- Ngo, T. M. H., Viland, P., Zaharia, G. & Helard, J.-F. (2008). Balanced QPSK space-time trellis codes, *Electronics Letters* 44(16): 983–985.
- Ngo, T. M. H., Zaharia, G., Bougeard, S. & Helard, J. (2007). A new class of balanced 4-PSK STTC for two and three transmit antennas, pp. 1–5.
- Tarokh, V., Seshadri, N. & Calderbank, A. (1998). Space-time codes for high data rate wireless communication: performance criterion and code construction, *Information Theory, IEEE Transactions on* 44(2): 744–765.
- Ungerboeck, G. (1987a). Trellis-coded modulation with redundant signal sets part I: Introduction, *IEEE Communication Magazine* 25: 5–11.
- Ungerboeck, G. (1987b). Trellis-coded modulation with redundant signal sets part II: State of the art, *IEEE Communication Magazine* 25: 12–21.

IntechOpen

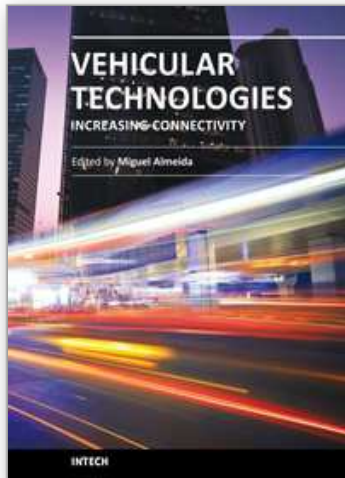

Vehicular Technologies: Increasing Connectivity

Edited by Dr Miguel Almeida

ISBN 978-953-307-223-4

Hard cover, 448 pages

Publisher InTech

Published online 11, April, 2011

Published in print edition April, 2011

This book provides an insight on both the challenges and the technological solutions of several approaches, which allow connecting vehicles between each other and with the network. It underlines the trends on networking capabilities and their issues, further focusing on the MAC and Physical layer challenges. Ranging from the advances on radio access technologies to intelligent mechanisms deployed to enhance cooperative communications, cognitive radio and multiple antenna systems have been given particular highlight.

How to reference

In order to correctly reference this scholarly work, feel free to copy and paste the following:

P. Viland, G. Zaharia and J.-F. H elard (2011). New Method to Generate Balanced 2n-PSK STTCs, Vehicular Technologies: Increasing Connectivity, Dr Miguel Almeida (Ed.), ISBN: 978-953-307-223-4, InTech, Available from: <http://www.intechopen.com/books/vehicular-technologies-increasing-connectivity/new-method-to-generate-balanced-2n-psk-sttcs>

INTECH
open science | open minds

InTech Europe

University Campus STeP Ri
Slavka Krautzeka 83/A
51000 Rijeka, Croatia
Phone: +385 (51) 770 447
Fax: +385 (51) 686 166
www.intechopen.com

InTech China

Unit 405, Office Block, Hotel Equatorial Shanghai
No.65, Yan An Road (West), Shanghai, 200040, China
中国上海市延安西路65号上海国际贵都大饭店办公楼405单元
Phone: +86-21-62489820
Fax: +86-21-62489821

© 2011 The Author(s). Licensee IntechOpen. This chapter is distributed under the terms of the [Creative Commons Attribution-NonCommercial-ShareAlike-3.0 License](#), which permits use, distribution and reproduction for non-commercial purposes, provided the original is properly cited and derivative works building on this content are distributed under the same license.

IntechOpen

IntechOpen