

We are IntechOpen, the world's leading publisher of Open Access books Built by scientists, for scientists

4,800

Open access books available

122,000

International authors and editors

135M

Downloads

Our authors are among the

154

Countries delivered to

TOP 1%

most cited scientists

12.2%

Contributors from top 500 universities



WEB OF SCIENCE™

Selection of our books indexed in the Book Citation Index
in Web of Science™ Core Collection (BKCI)

Interested in publishing with us?
Contact book.department@intechopen.com

Numbers displayed above are based on latest data collected.

For more information visit www.intechopen.com



Power Quality in Public Lighting Installations

Peter Janiga and Dionyz Gasparovsky
*Slovak University of Technology in Bratislava
Slovakia*

1. Introduction

Power quality in public lighting networks is yet not sufficiently studied today. New conditions and requirements arise as a consequence of rapid application of new technologies like LED lighting, lighting control and monitoring, adaptive lighting systems etc. Optimization of reliable and efficient service of public lighting systems can be only achieved if behaviour of individual elements within the system are well described.

For erection, operation and re-construction of public lighting networks it is important to have knowledge on behaviour of the network in different conditions. Because currents primarily depend on the supply voltage, it is essential to analyze electrical parameters not only under standard conditions but also under operational conditions. These comprise e.g. distorted or regulated voltage supply.

Non-linearity of electrical parameters of luminaires seems to have significant influence on power quality. In luminaires with conventional ballast, non-linearity is generated by discharge lamp as well as choke. The older type of lamp or choke (in aged existing systems), the worse characteristics. Luminaires with electronic ballasts do not provide this effect and are helpful to maintain “clear” networks. However, in the field of public lighting, unlike in interior lighting with fluorescent lamps for instance, electronic control gears still do not reach any comparative popularity. LED luminaires of diverse quality now intrude the market though technology level, as agreed by experts on many forums, do not compete with available traditional lighting approaches, is known for unsolved problems and needs a series of further developments. From the electrical point-of-view, control gears for LED lamps are similar to electronic ballasts. Supply voltage provided by switch-type source is rectified first. Semiconductor components of rectifier act as non-linear elements. Though these control gears have to be equipped with filter of harmonics, many LED luminaires still lack such circuits.

For assessment and investigation of power quality characteristics it is indispensable to understand the behaviour of individual elements and then the behaviour of network as a whole. Distribution network impacts the public lighting network (via transformer) and vice versa. To describe the nature of this two-way influence in details is very complicated, thus certain simplifications in order to speed up calculations are applied. For example, nominal values of harmonic voltages or currents can be used instead of distorted (non-harmonic) characteristics. Or for accurate calculation of steady-state network with discharge lamps measured values can be used instead of complicated description of discharge parameters.

2. Elements of public lighting networks

2.1 Luminaires

Luminaires with discharge lamps (fig. 1 on the left) are the major luminaire types in public lighting systems. LED luminaires (fig. 1 on the right) are installed still rarely and in most of cases only as experimental or demo projects. Discharge lamp as a non-linear element is responsible for deformation of current. Properties of light sources at nominal voltage supply are very similar in production of harmonic frequencies. Fig. 2 depicts V-A characteristics of most commonly used lamps in public lighting – compact fluorescent lamps PL-L and high-pressure sodium lamps. Lamp power has only minimum affect to the shape of V-A characteristic. But if the supply voltage is distorted (from ideal sinusoidal curve), deformation of characteristic is more than evident; this is a consequence of changes in gas ionization inside the lamp's burner.

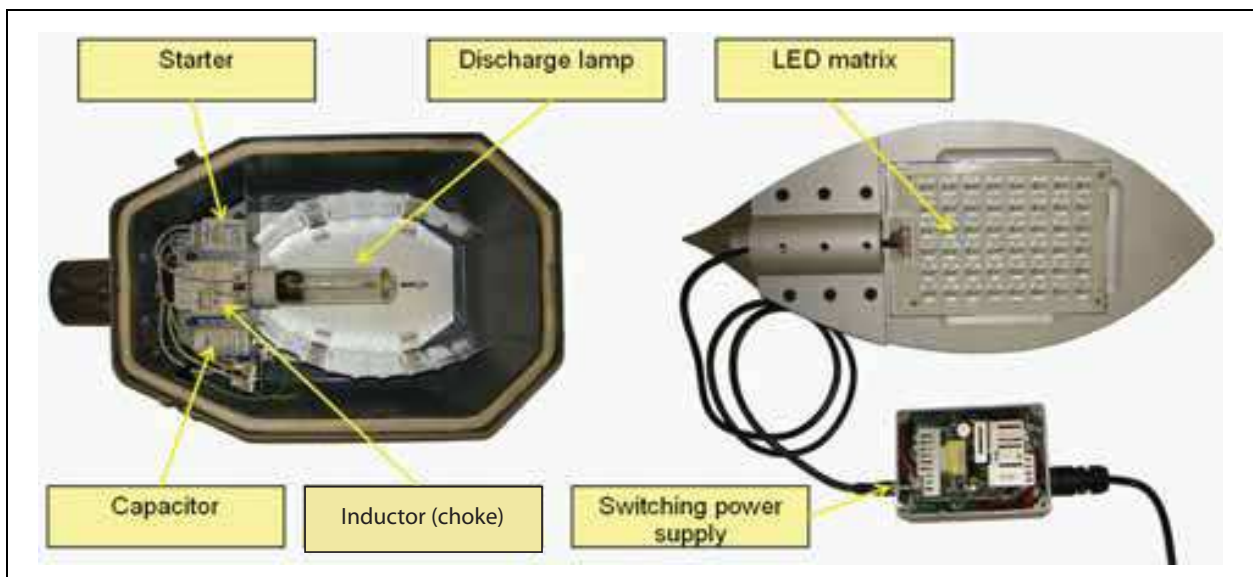

Fig. 1. Luminaire with discharge lamp and LED luminaire

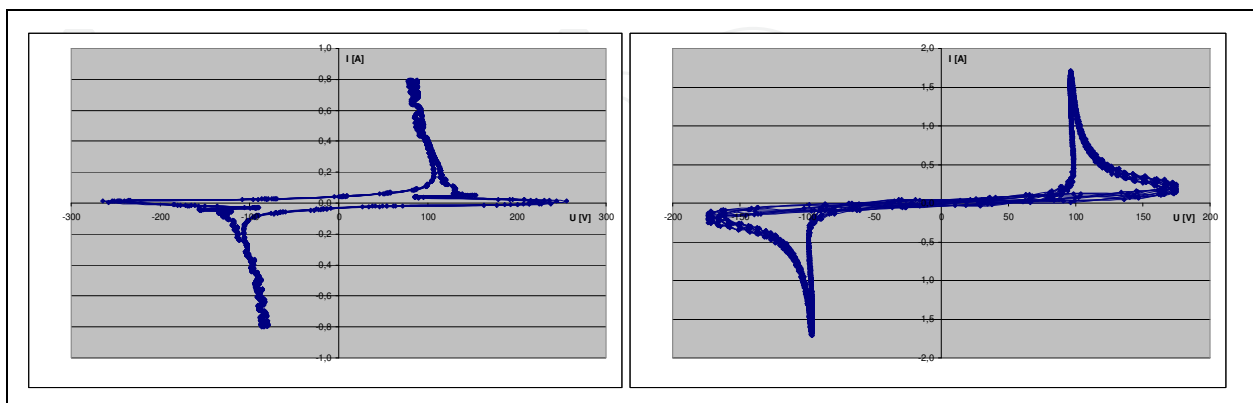

Fig. 2. V-A characteristics of compact fluorescent lamp PL-L (left) and high-pressure sodium lamp (right)

Lamp's ambient temperature is another factor having a significant influence on gas ionization. Low-pressure discharge lamps (including popular PL-L compact fluorescent

lamps) are particularly sensitive to low temperatures, therefore, installation of luminaires with this type of lamps should be carefully deliberated. There exist solutions with “thermal cap” on the CFL’s tube cold point (tip of the lamp) to suppress this effect.

Order of harmonic	HPS lamp 70 W	HPS lamp 100 W	CF lamp 36 W	MH lamp 150 W	MH lamp 400 W
0	0,0 %	0,0 %	0,0 %	0,7 %	0,1 %
1	100,0 %	100,0 %	100,0 %	100,0 %	100,0 %
2	0,3 %	0,3 %	0,6 %	0,4 %	0,3 %
3	18,0 %	18,0 %	21,6 %	17,3 %	13,3 %
4	0,3 %	0,2 %	0,4 %	0,2 %	0,2 %
5	4,5 %	3,6 %	2,2 %	3,1 %	2,7 %
6	0,2 %	0,2 %	0,5 %	0,2 %	0,2 %
7	3,6 %	3,3 %	3,2 %	2,6 %	1,3 %
8	0,2 %	0,1 %	0,4 %	0,2 %	0,2 %
9	1,7 %	1,3 %	1,3 %	0,7 %	0,2 %

Table 1. Harmonic content of a public lighting luminaire with inductive ballast supplied by ideal sinusoidal voltage

Key: HPS = High Pressure Sodium, CF = Compact Fluorescent, MH = Metal Halide

Current flowing through a discharge lamp depends (besides other factors) on the age of lamp. This effect is namely sharp for metal halide lamps. Approaching the end of lamp’s life, rectifying effect may occur. Therefore, control gear should be equipped with overload protection circuits.

Table 1 shows that luminaires with magnetic ballasts generate mainly the third harmonic of the current. Values in table 1 have been acquired by measurements of new, duly aged lamps, and it is clear that since the begin of operation the direct-current component is already present. Compensation of power factor in luminaires with conventional ballast is fixed to a particular value and during lifetime of the lamp the system is variably undercompensated or overcompensated.



Fig. 3. Electronic ballast

Situation is different for luminaires with electronic ballasts (Fig. 3) and for LED based luminaires (Fig. 1 on the right), where voltage is rectified prior to further modification of supply parameters. Here a different spectrum of harmonics can be observed (see table 2). Harmonic content depends on properties of harmonic filter, if there is any. For high-quality filters the content of harmonics can be decreased down to minimum values. In comparison to luminaires with inductive ballasts, harmonic content is not so much influenced by quality of power supply.

Order of harmonic	LED luminaire without filter of harmonics	LED luminaire with filter of harmonics	HPS lamp 150 W (electronic ballast with filter of harmonics)
0	0,0 %	9,2 %	0,0 %
1	100,0 %	100,0 %	100,0 %
2	0,1 %	1,4 %	0,4 %
3	21,6 %	63,0 %	8,9 %
4	0,2 %	1,0 %	0,3 %
5	6,2 %	29,3 %	2,0 %
6	0,2 %	0,8 %	0,1 %
7	3,6 %	18,2 %	1,4 %
8	0,2 %	0,8 %	0,1 %
9	1,8 %	18,7 %	1,1 %
10	0,1 %	0,9 %	0,0 %
11	1,4 %	11,8 %	0,8 %

Table 2. Harmonic content of a public lighting luminaire with electronic ballast

In electronic ballasts internal wiring has to fulfil requirements to avoidance of interference with surrounding devices that are operated on higher frequencies. In EU, emissions shall be in accordance with the norm EN 55 015.

Electronic ballasts (EB) used in public lighting in comparison to similar devices used in interior lighting can have circuits for regulation of output power according to preset switching profile (ON-OFF-DIM cycles with reduced power in dimming mode). Electronic ballasts cannot be connected to networks with central voltage regulator because decreased supply voltage for ballast may malfunction the lighting operation. Light dimming in EB is possible thanks to controlled high-frequency oscillator.

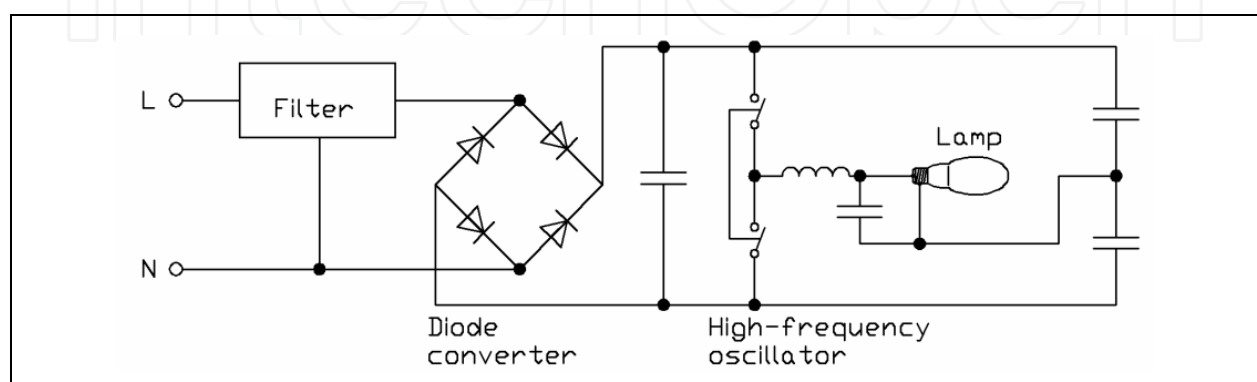

Fig. 4. Circuit diagram of an electronic ballast

Input filter (see fig. 4) limits the effect of current deformation and protects against random high-frequency pulses that may appear in supply network (e.g. as a result of switching processes). Right to the rectifier bridge there is a coupling capacitor for smoothing of rectified voltage. Next stage of signal processing consist of two transistors used to generate a high-frequency signal for maximized power. The frequency must be above the range of audible sound, i.e. 20 kHz (upper limit lies about 100 kHz). Choke is wired in series with lamp. Choke is responsible for limitation of current through lamp. Capacitor connected parallel to the lamp is used for creation of the ignition voltage.

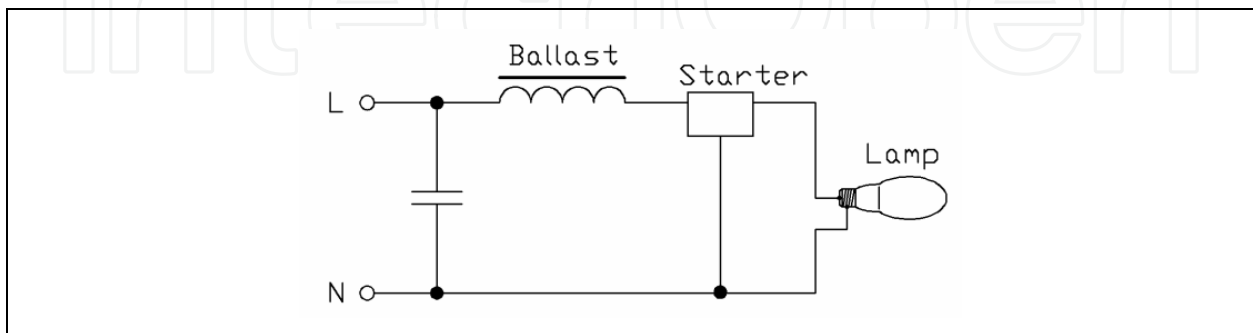

Fig. 5. Circuit diagram of a magnetic ballast

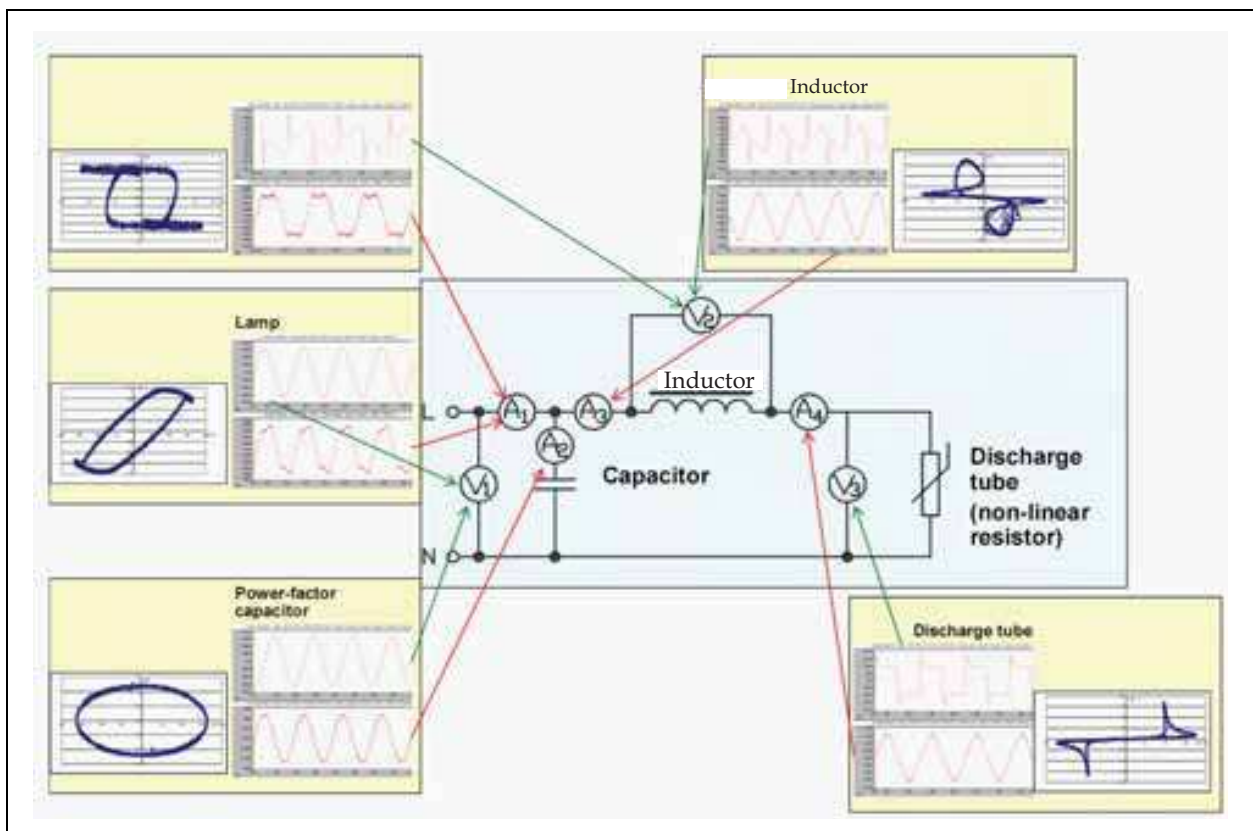

Fig. 6. Behaviour of voltage and current in a discharge lamp

Magnetic (conventional) ballasts (energy efficiency index $EEI = B1, B2, C, D$ according to CELMA) consist of choke, capacitor and starter. Thermal losses are prevailing in this type of ballasts. Losses are originated in windings of the choke by flowing currents and also by

hysteresis of the core. Level of losses depends on mechanical construction of the ballast and wiring of its windings.

Simple choke is a dominant ballast type for high-pressure discharge lamps. It has single winding on a core, due its construction it is simple and cheap. Choke is connected in series with lamp (Fig. 5). Provides only limited regulation possibilities by input voltage. Ignition current is very high, thus, the whole circuit must be constructed to withstand such currents. During operation of magnetic ballast, non-harmonic currents flow as a result of non-linearity of the lamp. Fig. 6 shows V-A characteristics of individual components of a luminaire in a steady-state condition. Besides non-linear V-A characteristic of lamp a hysteresis of choke is also depicted. This hysteresis also contributes to the resulting deformed current flowing through a luminaire. Compensating capacitor shifts the current phase in order to get better power factor. But only phase of the first harmonic is affected, higher-order harmonic currents have a phase shift. If this type of ballast has a 20 % content of harmonics (related to the first harmonic), this part of current remains with a phase shift and thus energy losses are increased.

Luminaires with conventional ballasts are usually equipped with compensating capacitor which is used to increase the PF factor and to compensate the reactive power. Values of active and reactive power vary during stabilization of discharge (fig. 7). Shortly after switch-on of luminaire the total current is overcompensated, because current flowing through the choke and lamp are smaller than nominal current.

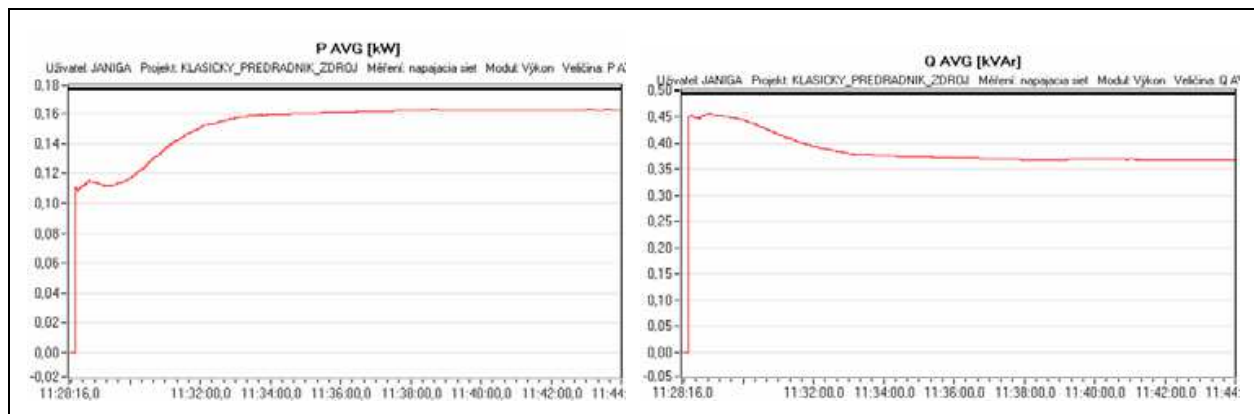

Fig. 7. Active and reactive power during start-up of the luminaire with inductive ballast

Measurements of capacitors from outdated roadlighting luminaires (over 30 years of operation) showed that the drop is very small, practically neglectable. Although these capacitors are thermally stressed, measured capacity value was still within the tolerable range.

2.2 Cables

Cables realize conductive connections between network nodes. Requirements to technical parameters of cables used in public lighting systems are established in the norm IEC 60 446. These heavy-current leads can be supplied by additional control wires.

Network lines can have one of these forms:

- **Overhead conductors** – non-isolated wires on concrete masts or wooden poles
- **Buried cables** – mainly in city centres or residential areas where emphasize is given to visual “invisibility” of infrastructures

- **Overhead cables** combining the easy access for maintenance of overhead lines and compactness of cabled wires; these are used for public lighting reconstruction as replacement of bare conductors (e.g. to avoid short-circuits caused by winds) or to bypass local faults etc.

Only resistance comes to calculation as an input parameter. Reactance is much lower, therefore neglectable. Measurements in a real network with 9 luminaires confirmed low influence of reactance. Harmonic content do not vary with cable length (distance from switchboard) but only depends on degree of voltage distortion, small differences in characteristics due to the age of lamp and deviations of electrical parameters as shown on Fig. 8.

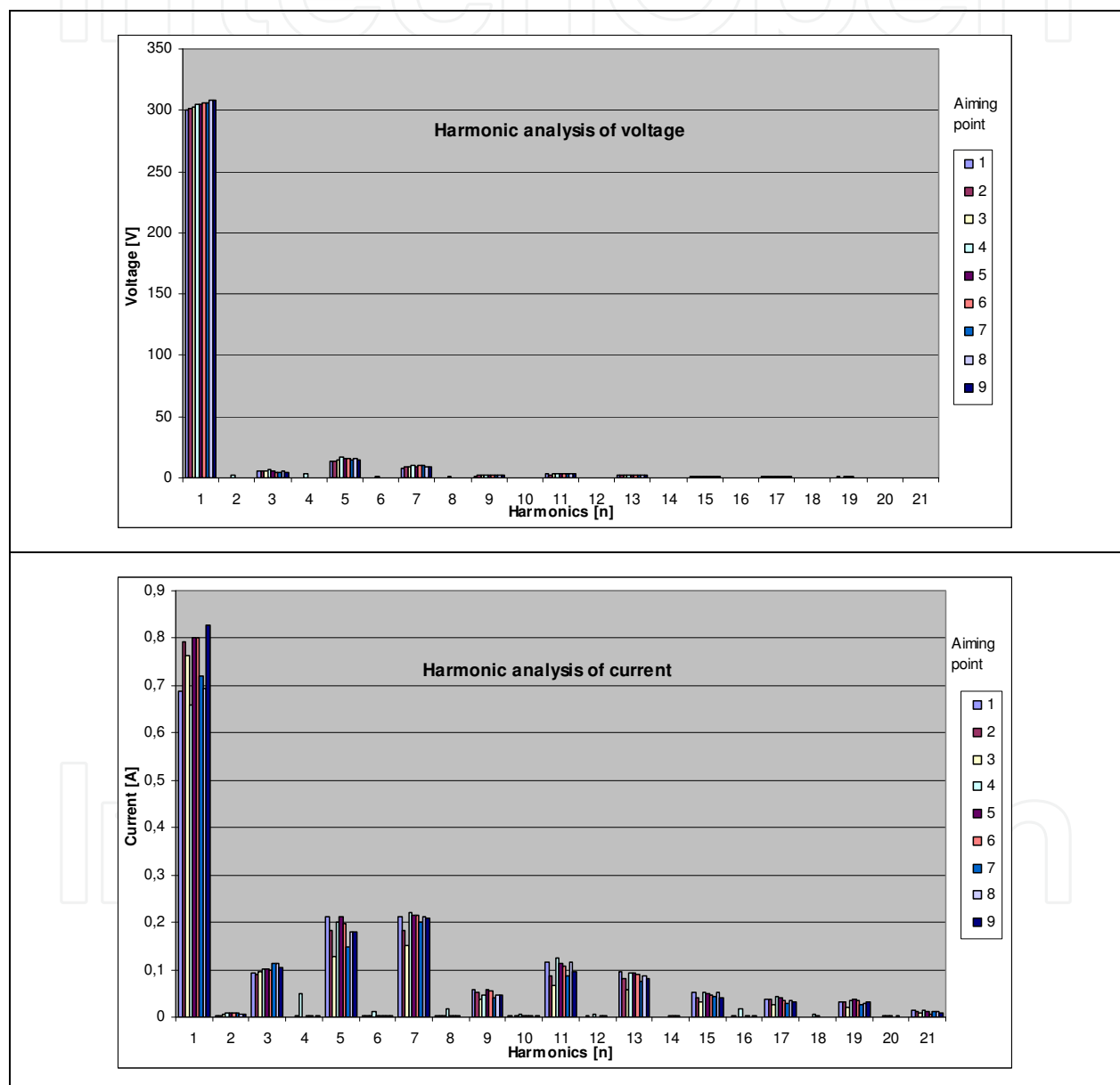

Description of the measured lighting system:

Spacing of light poles: 30 m

Network type: buried cables

Material of conductors: aluminium core, 16 mm² cross-section

Fig. 8. Harmonic content versus length of line

Public lighting systems are supplied by means of primary leads, terminated in a distribution box (Fig. 9) equipped with main fuse, kWh-meter, lighting control and circuit breakers on outputs where secondary network is connected. Secondary side is branched to one or more sections. Secondary network is typical for tree-type topology with linear branching, loops are constructed only in small number of cases, sometimes formed unintentionally as a result of unprofessional maintenance. Buried cables are usually connected directly to pole's terminal block and continue from pole to pole. In some countries, junction of smaller size cable by means of T-connector is preferred instead. In case of overhead lines (bare or isolated), always an auxiliary wire enters the luminaire, terminated on its terminal block.

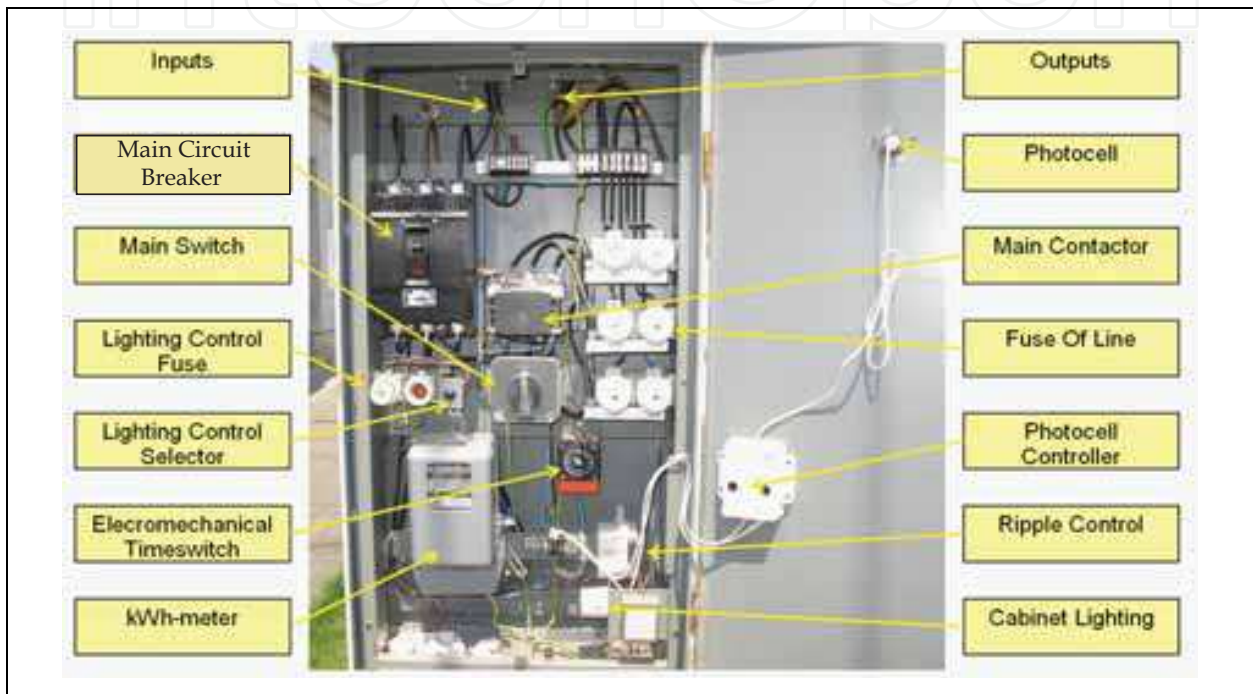

Fig. 9. Public Lighting Switchboard

Quality of network is determined by several factors like materials of cables or conductors, arrangement and fixation of lines, load of conductors. Fault rate of lines has a strong impact on operational costs because any servicing of buried cables is very time-consuming, personnel demanding and therefore expensive.

Many older systems of public lighting utilize common PEN conductor shared with distribution network, e.g. supplying residential houses. This solution is based upon efforts to save one wire years ago. Today such approaches are not allowed due to many reasons but still there are many older systems operated this way. Shortcomings are evident – overload of the PEN conductor and, what is even more important, mutual influence of two otherwise separate networks. This problem only concerns overhead lines. If re-construction of lighting systems is planned, one of the most important measure is to fully separate the public lighting network from distribution network.

3. Problems in public lighting networks related to power quality

Insufficient power quality characteristics often do not appear immediately but after certain period of time, e.g. after long-term stress of isolation due to overload of conductors. It is

therefore very important to know and recognize possible difficulties, problems and their consequences.

3.1 Distortion of supply voltage

Currents flowing through public lighting networks can be calculated from nominal values, i.e. current values at ideal sinusoidal voltage.

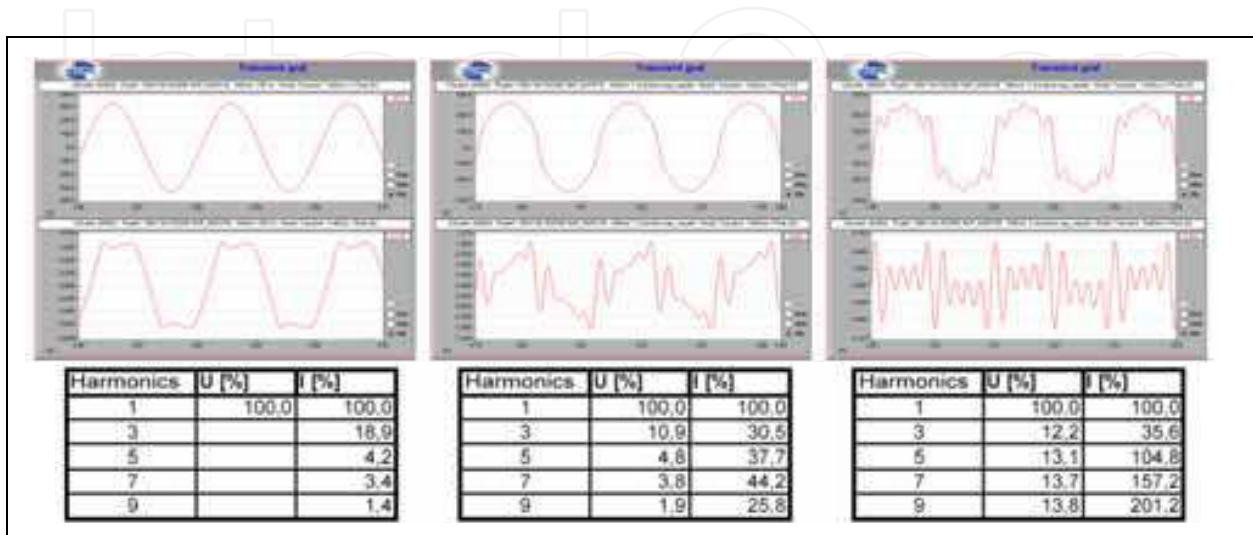

Fig. 10. Example of the current wave deformation depending on supply voltage deformation for a luminaire with conventional ballast

In a real operation, waveform of voltage always less or more deviates from its ideal shape. How this voltage deformation influences to the deformation of current waveform in a luminaire, is depicted on Fig. 10.

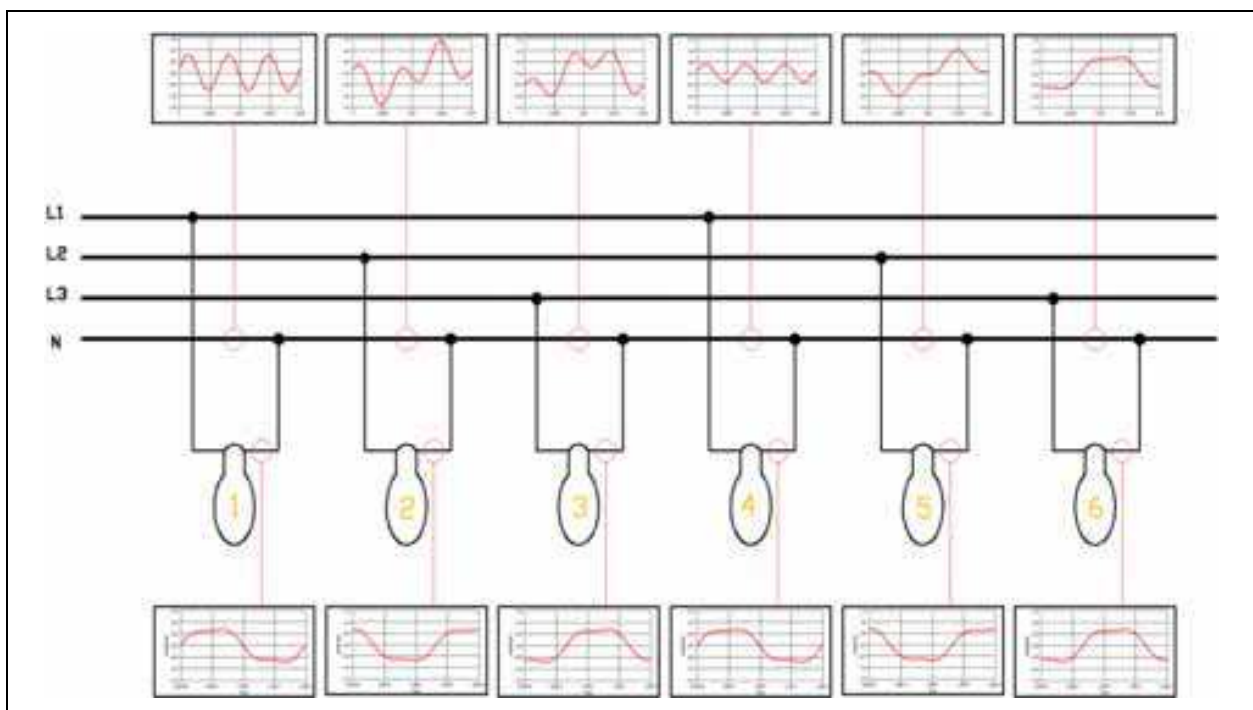

Fig. 11. Emersion of triplen harmonics in the PEN conductor in public lighting networks

Increase of voltage distortion results in much higher increase of the current deformation. In three-phase networks the content of triplen harmonics may cause significant overload of the PEN conductor, leading to degradation of its insulation and consequent cable faults. Fig. 11 shows the emersion of these currents in PEN conductor.

Voltage distortion may also be initiated by noise, defined as an undesired broadband spectrum signal superposed to the basic harmonic voltage wave. Electronic devices generate the major part of noise in networks. Luminaires with conventional ballasts are sensitive to the power quality of supply voltage and even small steps are transmitted and magnified to the current waveform. Such small variation of voltage can be caused by semiconductor regulators, supply source etc. Fig. 12 shows how small noise can impact the waveform of current in a luminaire with conventional ballast due to gradient of voltage. These small and rapid changes are transmitted via choke to the discharge lamp, influencing the gas ionization in its burner.

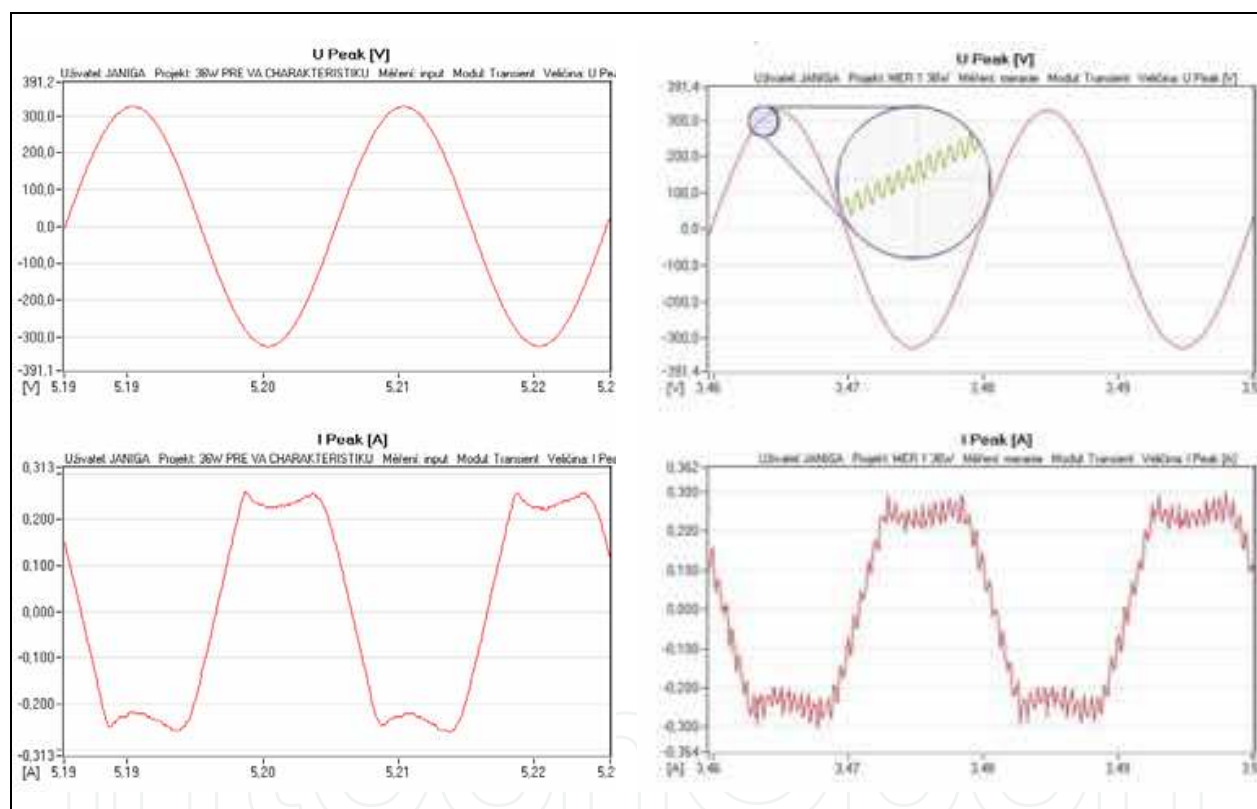

Fig. 12. Influence of the power quality of supply source to the waveform of current (supply by sinusoidal voltage and supply by voltage with small oscillations)

Operation of luminaires with electronic ballasts can help to eliminate flows of non-harmonic currents. Smoothing of the current waveform can be performed by means of filters to less or more extent, depending on particular requirements. Generally spoken it is impossible to obtain again an ideal undistorted waveform. Example is shown on Fig. 13. When current is passing through the zero point, small portion of harmonics is not filtered. In this case, resulting value of THD_I is 10 %. Electronic ballasts in comparison to inductive ballasts benefit from almost zero phase shift. Thus, the network do not transmit neither any distortion power nor any reactive power.

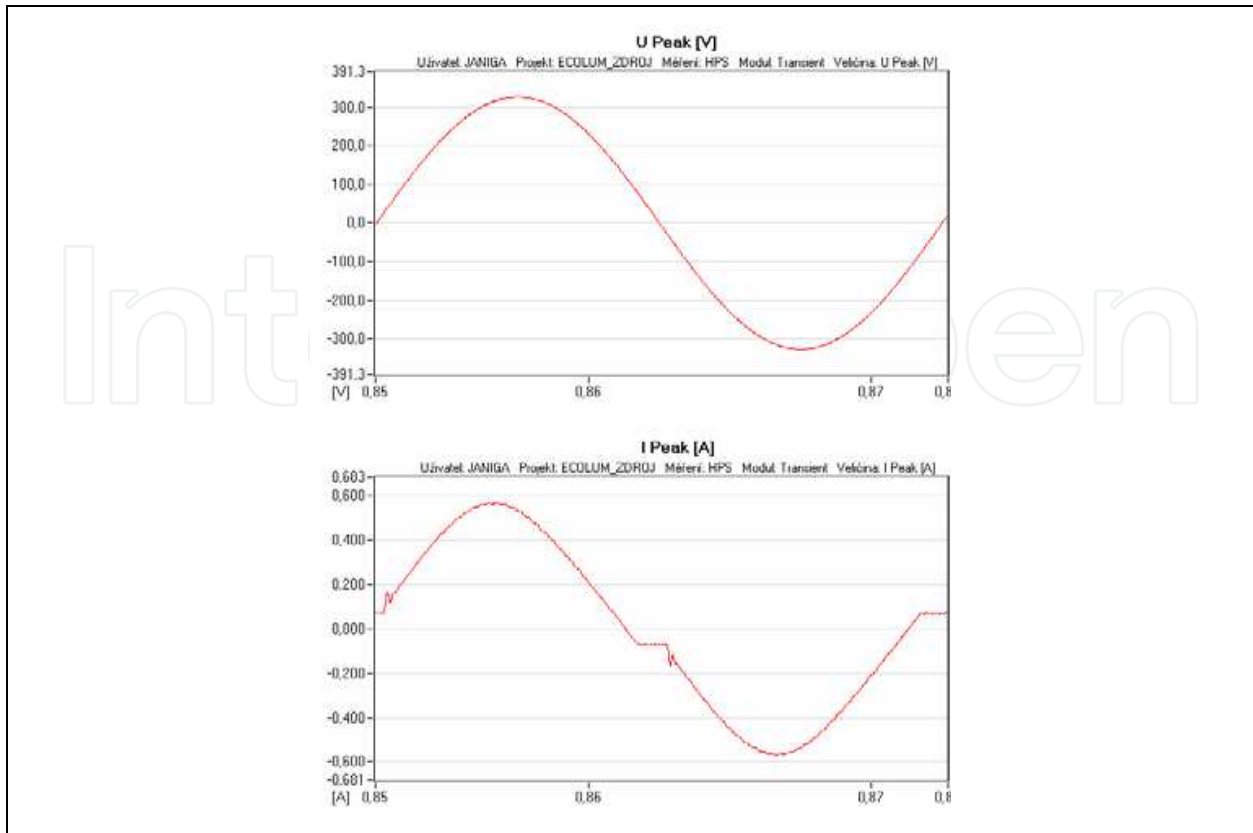

Fig. 13. Waveform of current for a luminaire with electronic ballast and filter of harmonics

3.2 Out-of-range voltage

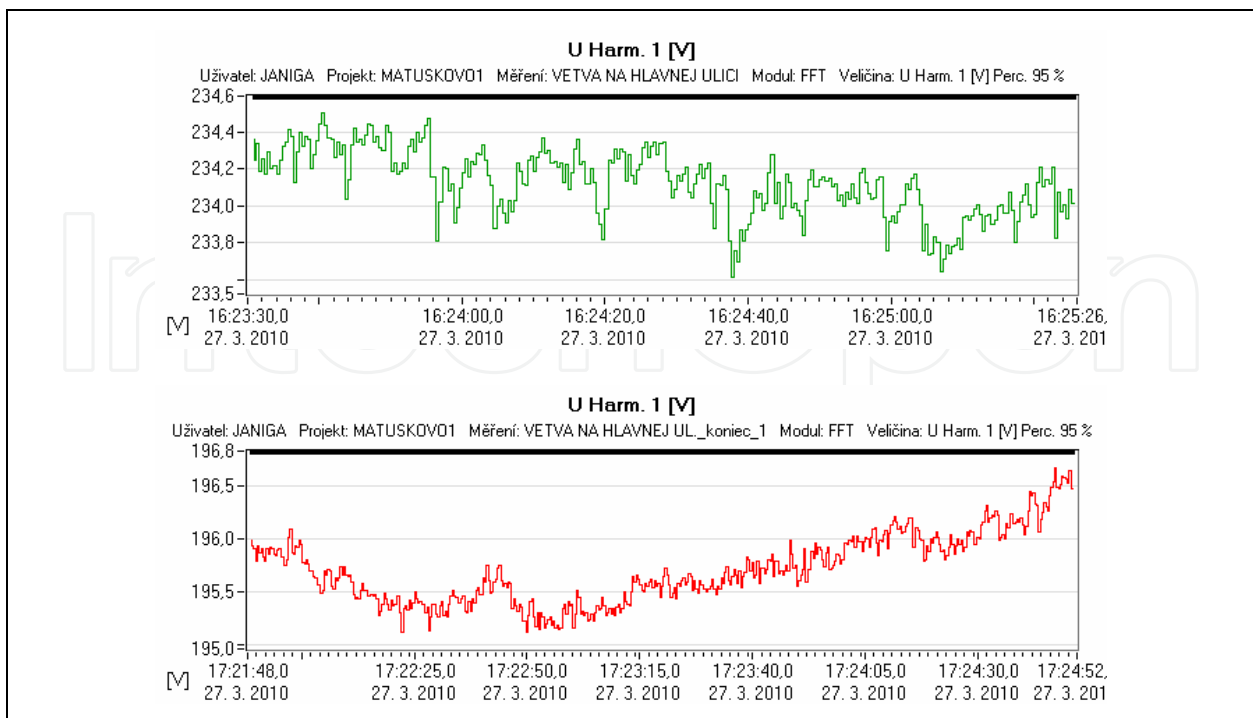

Fig. 14. Voltage at the begin (green) and end (red) of a network branch

For dimensioning of cross-section of conductors of public lighting lines it is not sufficient to take into account solely the load carrying capacity, it is also necessary to check the voltage drops. This is particularly crucial for networks with central voltage regulators. Combination of an excessive voltage drop with decrease of supply voltage may lead to situations when discharge lamps located farther from the distribution box will not be able to maintain the stability of discharge and stop to lit. This problem concerns mainly luminaires with conventional ballasts and the effect depends on rated lamp power. The higher power the longer discharge (given by distance between electrodes in lamp's burner) and the higher voltage needed to keep the discharge in a stable burning state. Electronic ballasts can compensate smaller variations of voltage but these are not suitable (or applicable) for light dimming by voltage regulation.

Fig. 14 depicts results of measurement (Fig. 15) of voltage in a network with high-pressure mercury lamps (250 W) and buried cables. Topology of the networks is linear and its length is 1,5 km. Cable cores are made of aluminium with 16 mm² cross-section. In this network the voltage-related problem is strengthened during start-up of the operation when higher (so called starting) currents flow through conductors. This moment the luminaires are most sensitive to the level of supply voltage. Long tube compact fluorescent lamps PL-L (widely used in public lighting systems) at lower temperatures and voltage below 195 V were not able to start-up reliably.



Fig. 15. Measuring power quality in public lighting network

3.3 Short-time voltage variation

Transition effect shown on Fig. 16 was caused by third-party electricity consumer. This situation is very dangerous for luminaires because step changes of voltage may induce extensive current pulses on choke and/ or lamp. It is almost impossible to track the reasons of

faults of luminaires or network because there is no continuous monitoring of voltage or current. In spite of the fact that these faults are induced to the public lighting network from outside, service costs for repair of damaged part of system have to be covered by network operator. Passive elements cannot detect such small voltage changes and are therefore helpless in protection against them. The only option is limitation of current through network.

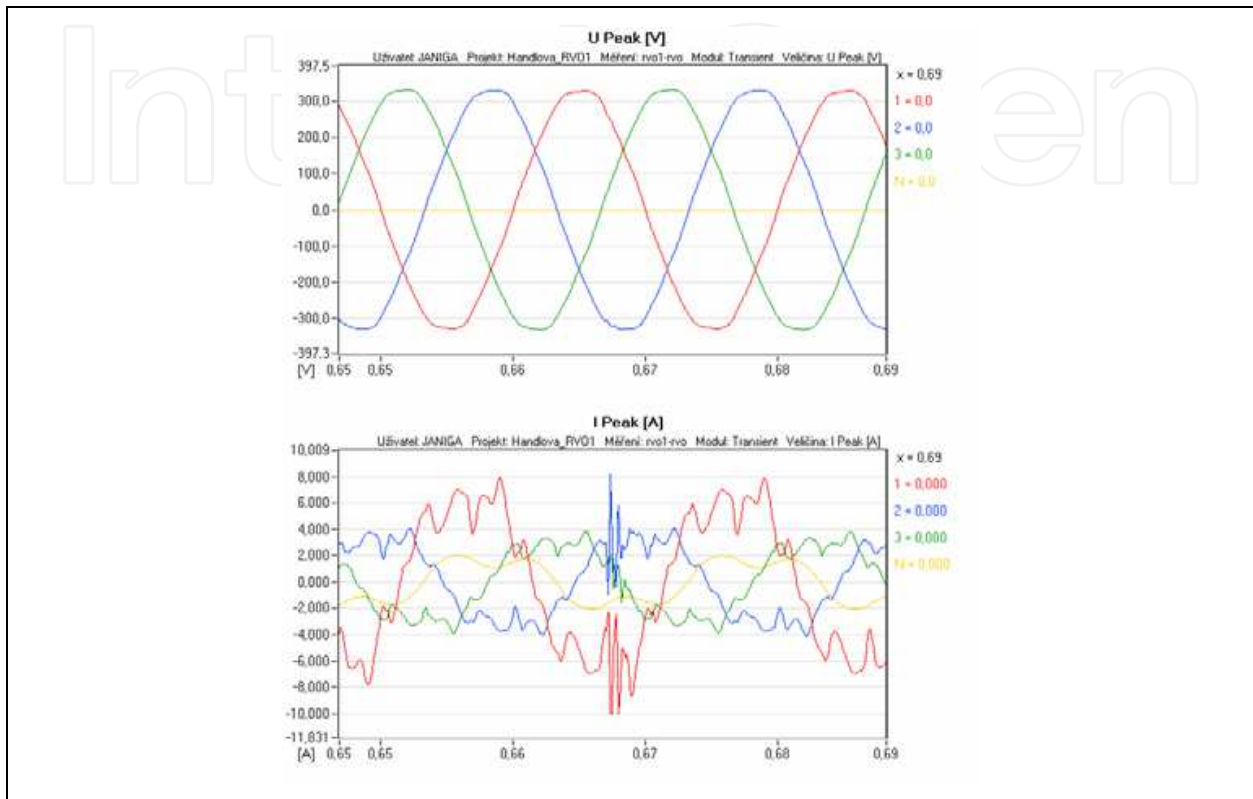

Fig. 16. Rapid voltage variation which induced a short-time transient effect

3.4 Incorrectly set voltage regulator

If a lighting regulator is installed, at the end of longer lines the voltage may drop below the range of stable operation even if recommended settings are satisfied. Regulator with smooth start-up is a particular case, voltage during operation of a regulator is shown on Fig. 17.

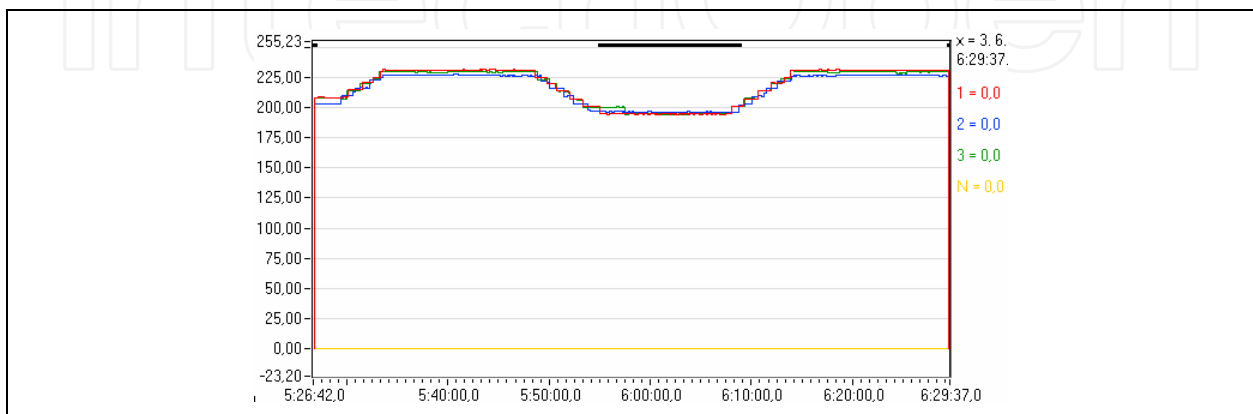

Fig. 17. Output voltage of a regulator

If the regulator starts with 210 V at the begin point of a branch (just on output of the distribution box with regulator), voltage at the end point of this line may fall below the level of ignition voltage for luminaires with metal halide lamps or compact fluorescent lamps (at low temperatures in particular).

4. Properties of network from the power quality point-of-view

4.1 Level of voltage and current waveform deformation

Internal wiring of a luminaire is shown on Fig. 18. Deformed voltage induces deformation of current on two parallel sub-circuits, one with capacitor and the other one with choke and lamp.

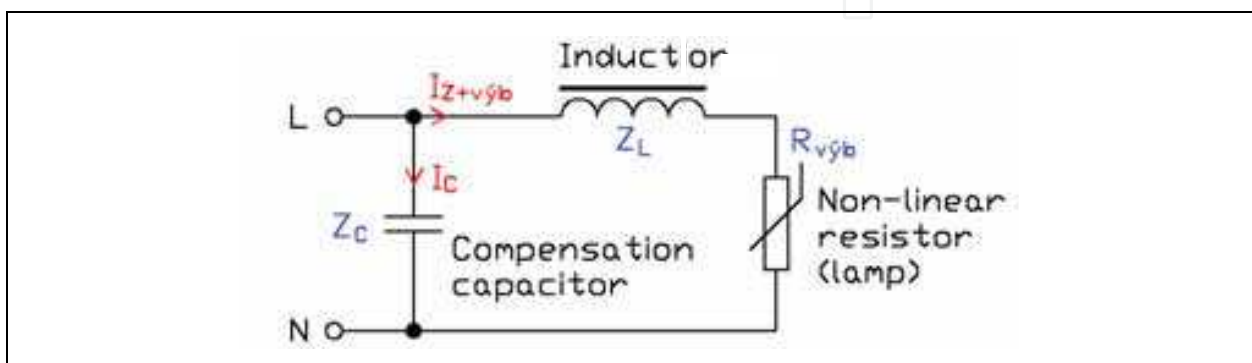

Fig. 18. Simplified arrangement of elements of a luminaire with conventional ballast

Impedance of capacitor is lower for higher-order harmonics than for the basic harmonic. If internal resistance is neglected, impedance of capacitor is given by the expression as follows:

$$Z_c = \frac{1}{j\omega C} \quad (1)$$

Description of impedance of the other sub-circuit is more complicated if supplied by distorted voltage, because behaviour of electrical parameters is linked to chemical and physical processes in filling gas and ability of gas to response to voltage variations what is not the subject of this publication.

The ballast choke has for higher-order harmonic voltages increased impedance and the lamp is typical for non-linear resistivity. There is a certain form of memory effect – same level of voltage in general do not correspond with the same level of current. If capacity and inductance of the lamp (discharge) is neglected, impedance of the choke and lamp can be calculated as follows:

$$Z_{L+v\gamma b} = R_L + j\omega L + R_{v\gamma b} \quad (2)$$

Situation for luminaires with electronic ballast or switch-type source is different. Behaviour is determined by V-A characteristics of rectifying diodes. Resulting characteristics of the current can be determined on the basis of calculated or measured impedance as portion of voltage and impedance for individual harmonics.

But if it is not possible to determine the function describing the luminaire's impedance, one of the ways how to describe the influence of distorted voltage to problems appearing in public lighting networks – is to use measured values.

Basic harmonic	Higher order harmonics of voltage			Higher order harmonics of current [%]							
	n	[%]	[V]	1	2	3	4	5	6	7	8
220				100	0,3	16,7	0,3	4,5	0,3	3,7	0,4
220	2	2	4,2	100	5,6	16,5	0,3	4,5	0,4	3,7	0,5
220	3	5	10,5	100	0,2	13,8	0,3	4,4	0,4	3,5	0,3
220	4	1	2,1	100	0,2	16,6	7,6	4,5	0,3	3,5	0,1
220	5	6	12,6	100	0,1	17	0,2	69,6	0,3	3,7	0,2
220	6	0,5	1	100	0,2	16,7	0,2	4,4	5,8	3,7	0,3
220	7	5	10,5	100	0,2	16,8	0,1	4,4	0,3	76,9	0,3
220	8	0,4	0,8	100	0,2	16,5	0,3	4,5	0,4	3,7	8,6
220	9	1,5	3,1	100	0,2	16,8	0,1	4,5	0,2	3,3	0,3
220	10	0,4	0,8	100	0,3	16,6	0,2	4,5	0,2	3,4	0,1
220	11	3,5	7,4	100	0,2	16,7	0,1	4,5	0,2	3,3	0,2

Basic harmonic	Higher order harmonics of voltage			Higher order harmonics of current [%]							
	n	[%]	[V]	9	10	11	12	13	14	15	16
220				1,7	0,3	1,2	0,1	1,0	0,1	0,7	0,2
220	2	2	4,2	1,5	0,3	1,3	0,2	1,0	0,2	0,6	0,1
220	3	5	10,5	1,8	0,3	1,4	0,4	1,0	0,3	1,0	0,3
220	4	1	2,1	1,8	0,1	1,4	0,2	0,8	0,1	0,8	0,1
220	5	6	12,6	1,7	0,1	1,7	0,2	1,0	0,2	0,9	0,2
220	6	0,5	1	1,9	0,4	1,1	0,3	1,0	0,2	0,9	0,2
220	7	5	10,5	1,7	0,2	1,4	0,2	1,4	0,2	1,4	0,3
220	8	0,4	0,8	1,4	0,4	1,4	0,4	1,2	0,3	0,5	0,3
220	9	1,5	3,1	30,1	0,4	1,9	0,5	0,9	0,4	0,8	0,1
220	10	0,4	0,8	1,9	10,8	1,5	0,6	0,5	0,6	0,9	0,3
220	11	3,5	7,4	2	0,4	93,6	0,6	0,9	0,2	0,1	0,2

Basic harmonic	Higher order harmonics of voltage			Higher order harmonics of current [%]						
	n	[%]	[V]	17	18	19	20	21	Sum of odd triplen harmonics	
220				0,6	0,2	0,6	0,2	0,6	19,7	
220	2	2	4,2	0,7	0,2	0,5	0,2	0,6	19,2	
220	3	5	10,5	0,5	0,2	0,8	0,3	0,4	17,0	
220	4	1	2,1	0,6	0,1	0,6	0,2	0,6	19,8	
220	5	6	12,6	0,2	0,3	0,6	0,2	0,4	20,0	
220	6	0,5	1	0,5	0,2	0,6	0,2	0,6	20,1	
220	7	5	10,5	0,5	0,3	0,8	0,2	1,1	21,0	
220	8	0,4	0,8	0,8	0,2	0,7	0,3	0,5	18,9	
220	9	1,5	3,1	0,7	0,3	0,5	0,5	1,2	48,9	
220	10	0,4	0,8	0,8	0,4	0,5	0,2	0,7	20,1	
220	11	3,5	7,4	0,7	0,2	0,7	0,2	1,6	21,3	

Table 3. Influence of the voltage waveform deformation on current waveform deformation

Influence of distorted voltage can be evaluated from partial deformations. Table 3 is an illustration of measured values of distorted current when luminaire with inductive ballast is supplied by voltage distorted within the limits prescribed by the EN 50 160 standard. During performance of individual measurements the basic harmonic frequency was distorted by superposition of only one harmonic of higher order. From measurement results follow that even if the voltage satisfies requirements of the norm regarding acceptable range of distortion, deformation of the current waveform is too high. Highlighted values in table 3 point to the case when a voltage harmonic influences the same harmonic of current. Sum of odd triplen harmonics of current for 9th harmonic of voltage exceeds 33 % (separately highlighted in the table) and in three-phase systems may cause increased overload of neutral wire in comparison to phase wires.

It can be concluded that limit values of voltage deformation cause significant current deformation. However, due to voltage derivation in particular time periods it is not possible to sum up deformations caused by individual single harmonics.

4.2 Starting current

To describe the behaviour of current during start-up as well as operation is too complicated as its waveform depends on several varying factors. Some of them vary with the age of luminaire (and its relevant parts), some with time of start-up, some depend on supply voltage and some are influenced by temperature etc. Start-up current can be easily measured.

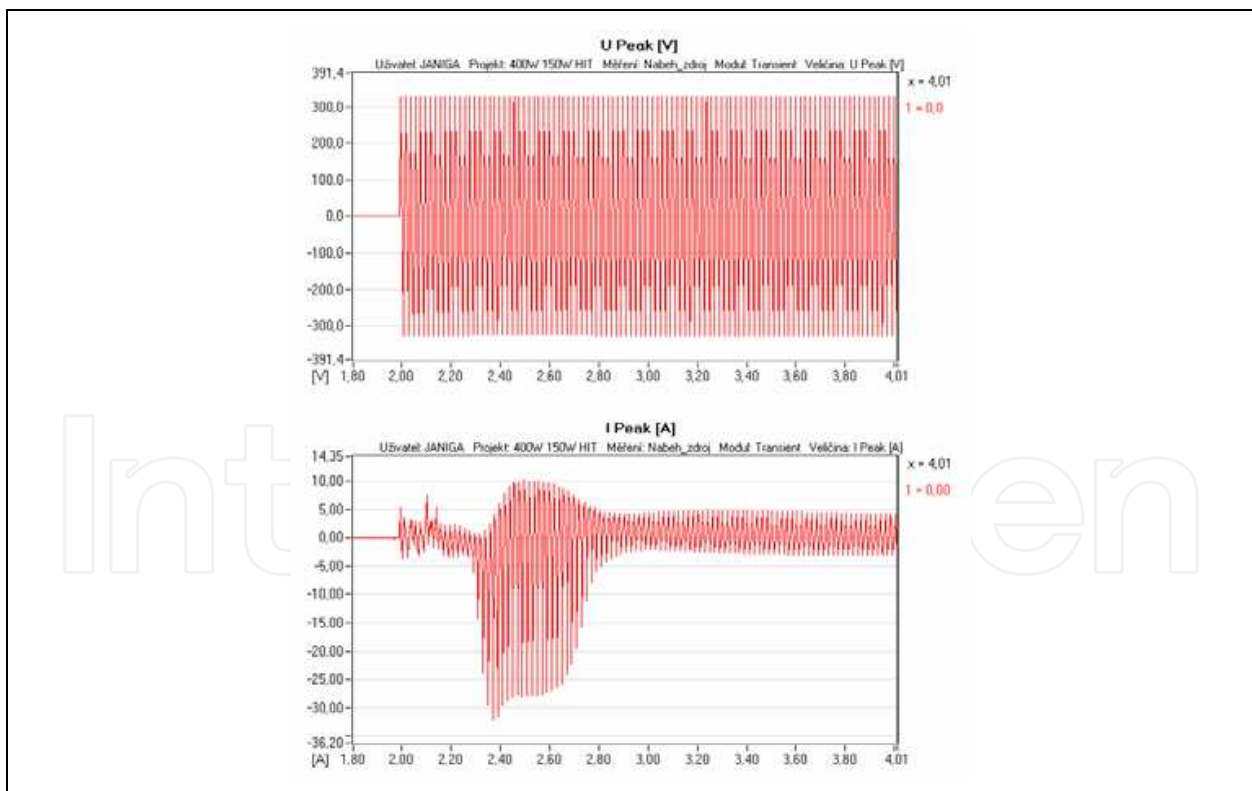

Fig. 19. Pulse start-up current in a luminaire with conventional ballast and 400 W metal halide lamp

This current can reach several tenths of amperes. Start-up duration depends on lamp type and if the start-up begins from cold state or warm lamp after e.g. mains interruption. For

metal halide lamps it is particularly important to allow the lamp cool down before attempts to start again. Start-up of luminaires with conventional ballasts may invoke high pulse start-up current or high re-ignition currents after short-time mains interruption.

Pulse current may occur first of all in luminaires with inductive ballasts. In luminaires with electronic ballast or switch-type source no pulse current is emerged. Transient phenomena are invoked by switching of discharge lamp through a choke. As it can be seen on fig. 19, pulse current may reach multiples of nominal current and lasts up to several periods.

With the age of metal halide lamps the rectifying effect is continuously increasing and therefore also the direct current component of the transient process. If the voltage in network is low or if discharge lamps come close to their end of life, due to unstability of arc the repetition of pulse current appearance in short periods of time may cause serious problems in network.

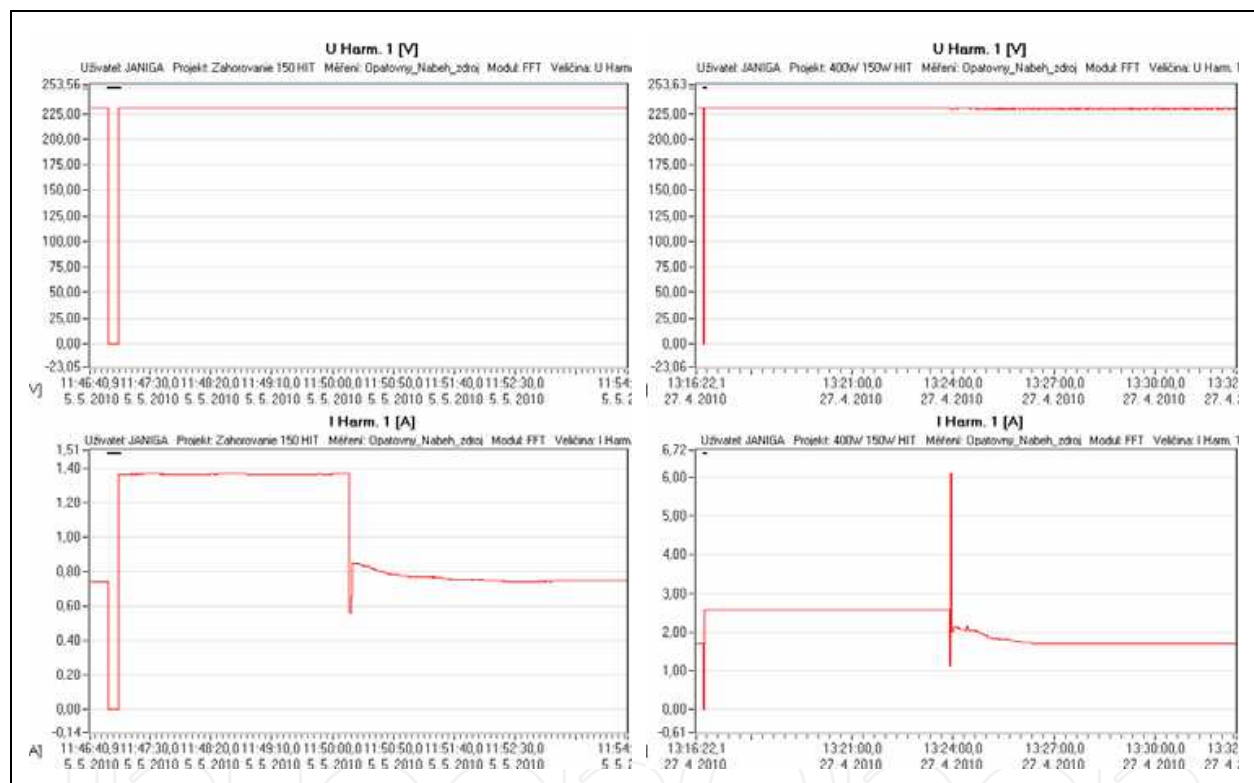

Fig. 20. Pulse re-ignition current in a luminaire with conventional ballast and 400 W metal halide lamp

Hot start-up of discharge lamps after short-time interruptions of voltage supply invoke, in general, different currents than during normal start-up. These characteristics depend on lamp type as well as choke. Re-starting current after voltage interruption is generally much higher than steady-state current in normal operation, as illustrated on fig. 20. Power factor is much worse as well because current flows only through the compensating capacitor. This situation may last as long as the gas in lamp's burner cools down. The duration depends on chemical composition of gas and may be up to 15 minutes.

Similar kind of problem may arise if a luminaire with fault lamp is continued to operate. Then its capacitor remains permanently connected to the network and contributes to the aggravation of power factor. This is a long-lasting problem in public lighting networks.

5. Model of public lighting network

5.1 Algorithm

Model of public lighting network is based on the method of loop currents. Luminaire as a non-linear consumer is substituted by a current source. Flow direction of this current source runs from positive to negative pole. Calculation of the steady state and determination of voltages in nodes of the network is processed by iterations. First step is to assume the same supply voltage on terminals of all luminaires. Current flowing through luminaire at given supply voltage is then measured and used to define the current source which will substitute a luminaire. Voltage values are determined in the next step. The iterations are then repeated until deviations are smaller than pre-defined boundary condition.

This model based upon substitution of luminaires by current sources seems to be the most suitable and practically applicable method for analyses of steady-state public lighting networks due to its simplicity because mathematical description of non-linear luminaire is overcomplicated. Assumptions of the model comprise single supply source and tree-structure of the network what is the prevailing situation in public lighting systems.

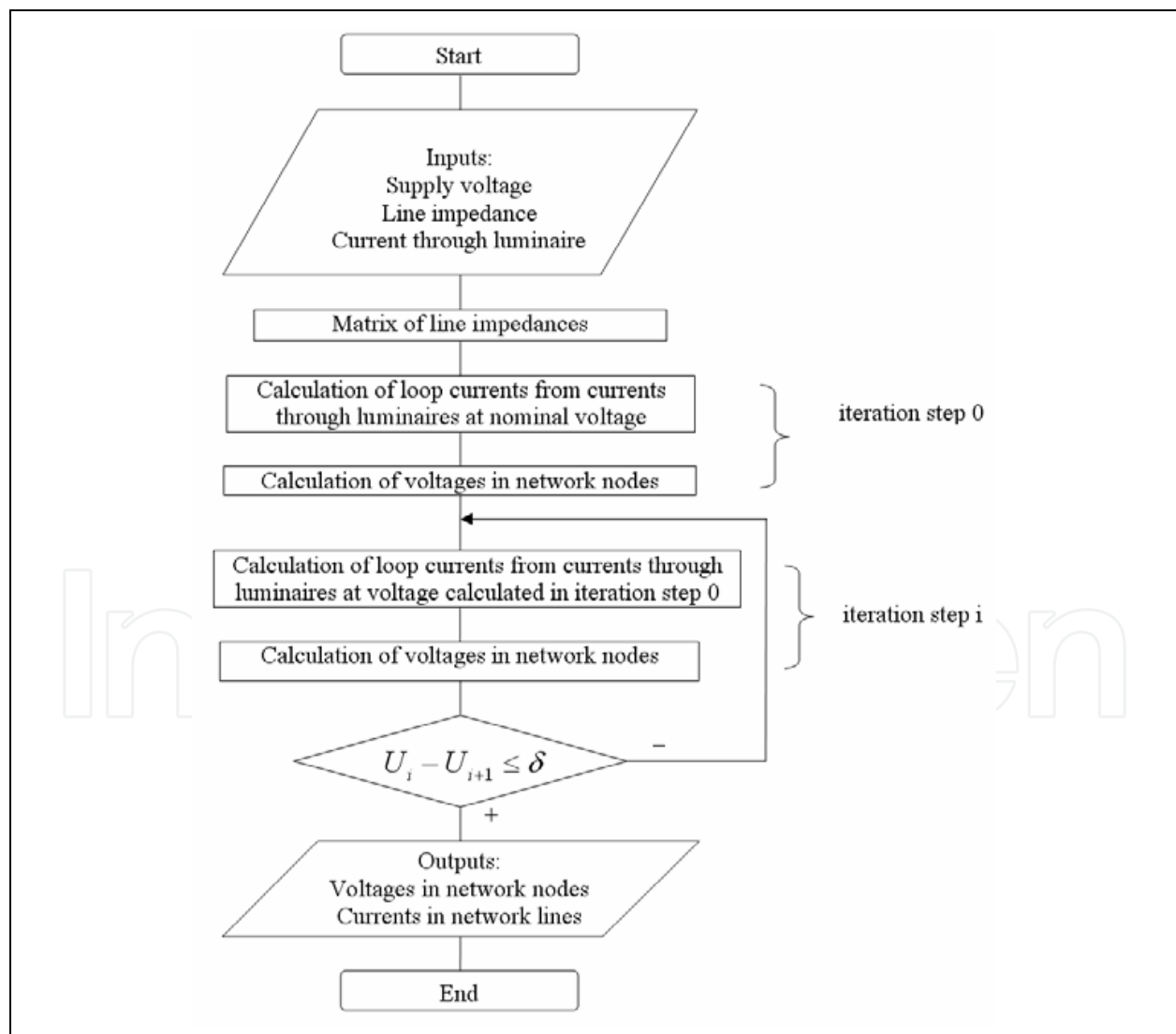

Fig. 21. Algorithm of calculation of steady-state public lighting network

5.2 Impedance of lines

In the framework of initial calculation, matrix of the line impedances \bar{Z}_v is to be assembled. It is a rectangular matrix of $n \times n$ dimensions where n is the number of luminaires in network.

$$\bar{Z}_v = \begin{pmatrix} Z_{11} & Z_{11} & \dots & Z_{11} \\ Z_{21} & Z_{22} & \dots & Z_{2n} \\ \vdots & \vdots & \ddots & \vdots \\ Z_{n1} & Z_{n2} & \dots & Z_{nn} \end{pmatrix} \quad (3)$$

The Z_{ii} element stands for impedance through which the i^{th} current loop is closed. If the shortest current loops are chosen, what means that current loops have common current sources only, then for single-phase network the matrix \bar{Z}_v is diagonal and the Z_{ij} element only appears in three-phase networks. An element apart from diagonal is a sum of impedances that are common for the i^{th} and j^{th} current loop. Fig. 22 shows an example of single-phase network and similarly fig. 23 shows example of three-phase network with impedances through which loop currents are closed as well as the manner how loop currents are determined.

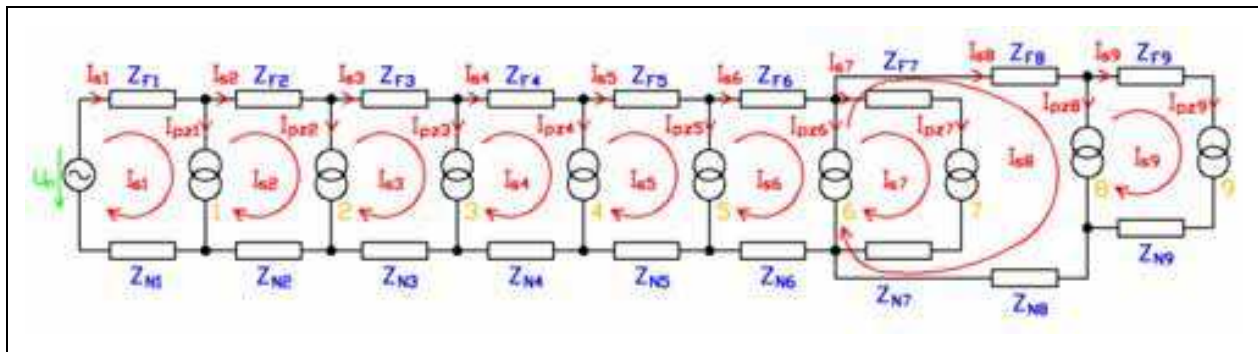

Fig. 22. Equivalent diagram of a network with current sources as substitutions of luminaires (example of a single-phase network)

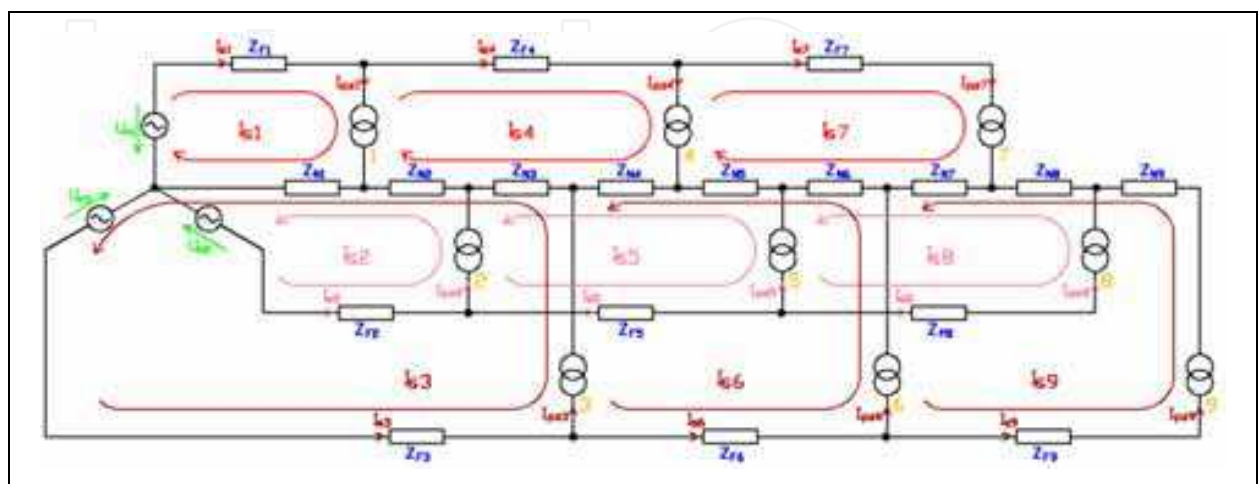

Fig. 23. Equivalent diagram of a network with current sources as substitutions of luminaires (example of a three-phase network)

Elements on the diagonal of matrix \bar{Z}_v can be calculated using the following formula:

$$Z_{ii} = Z_{Fi} + \sum Z_{Ni} \quad (4)$$

where Z_{ii} - line impedance through which the i^{th} loop is closed

Z_{Fi} - phase conductor impedance through which the i^{th} loop is closed

Z_{Ni} - neutral conductor impedance through which the i^{th} loop is closed

If minimum loop currents are defined then in three-phase networks the elements \bar{Z}_v apart from diagonal only consist of the neutral conductor impedance common for several loops.

$$Z_{ij} = \sum Z_{Nij} \quad (5)$$

where Z_{Nij} - impedance of neutral conductor common for i^{th} and j^{th} loop

5.3 Loop currents

Direction of current flows in network and assumed direction of current loops used for calculations are indicated on fig. 22 and 23. The loop current method does not allow to pass more than one loop current through a current source due to linear dependant equations describing the network. In the public lighting network model, however, the currents are known and the system of equations has a single solution. In zero step of iteration it is assumed that luminaires are supplied by equal level of voltage. Currents are consequently measured at the specified voltage. If currents flowing through luminaires are known, it is possible to calculate currents in lines in the zero step. Currents in phase conductors are in fact loop currents entering the calculation of voltages and the calculation is processed from the end of tree structure where only current from a single luminaire flows.

$$I_{si} = I_{pzi} \quad (6)$$

where I_{si} - current in i^{th} loop

I_{pzi} - current flowing through i^{th} luminaire.

Remaining loop currents are calculated as sum of currents flowing through those luminaires that are supplied via line of the given loop.

$$I_{si} = \sum I_{pzi} \quad (7)$$

5.3 Network node voltages

Voltages related to a loops can be calculated by multiplication of the matrix of line impedances with the matrix of loop currents.

$$\bar{U}_s = \bar{Z}_v \bar{I}_s \quad (8)$$

Rewriting the equation above into matrix form we obtain:

$$\begin{pmatrix} U_{s1} \\ U_{s2} \\ \vdots \\ U_{sn} \end{pmatrix} = \begin{pmatrix} Z_{11} & Z_{12} & \dots & Z_{1n} \\ Z_{21} & Z_{22} & \dots & Z_{2n} \\ \vdots & \vdots & \ddots & \vdots \\ Z_{n1} & Z_{n2} & \dots & Z_{nn} \end{pmatrix} \cdot \begin{pmatrix} I_{s1} \\ I_{s2} \\ \vdots \\ I_{sn} \end{pmatrix} \quad (9)$$

Network node voltages can be then calculated from the matrix of voltages related to loops. The matrix element \bar{U}_s represents a voltage difference on i^{th} luminaire and voltage in node from which the i^{th} luminaire is supplied.

$$U_{si} = U_{napi} - U_i \quad (10)$$

5.4 Model outputs

The model provides these main outputs:

- **Voltage on terminal blocks of luminaires:** these values allow to investigate if operation of the network do not induce voltages that may damage luminaires.
- **Currents flowing through the network:** these values allow to determine the backward impact of public lighting network on the supply network. It also allows to determine the current in neutral conductor which is often overloaded in three-phase networks.

Voltage and current values can be then used for calculation of parameters defining the distortion of voltage and power flows in the network.

Because calculations are based on iterations, it is suitable to use software tools (see fig. 24).

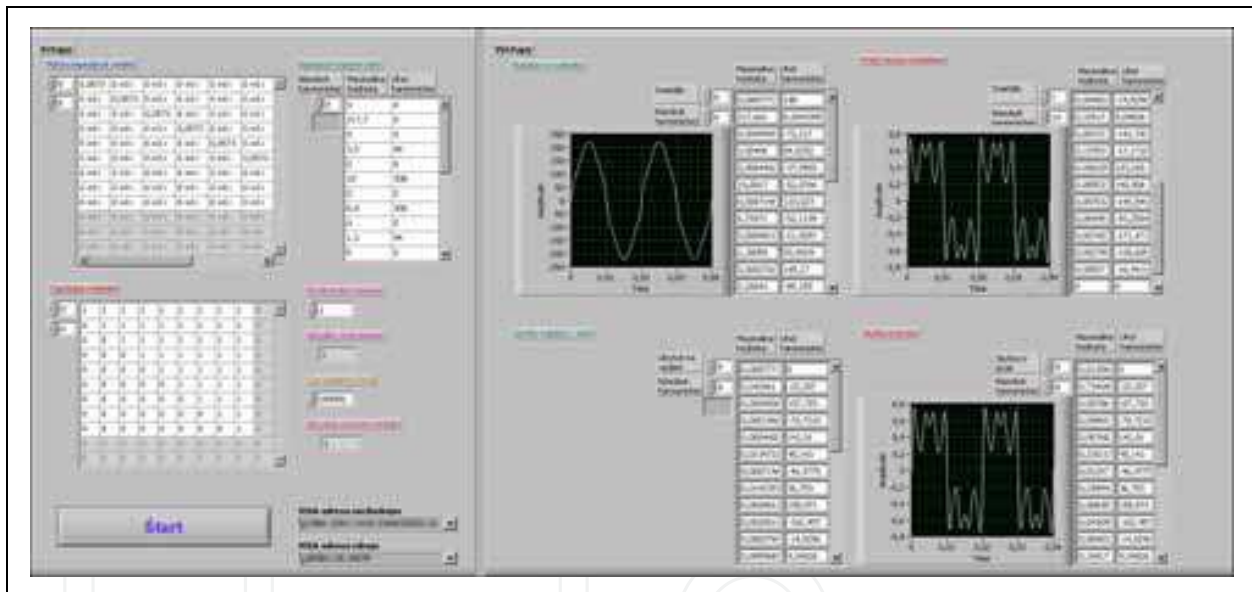

Fig. 24. Software for calculation non-harmonic voltages and currents in public lighting network

6. References

- [1] EN 50 160: Voltage characteristics of electricity supplied by public distribution networks
- [2] EN 60 555 - 2: Power supply harmonic emissions
- [3] IEEE 519-92: Recommended practice for monitoring electric power quality
- [4] Acha, E., Madrigal, M. (2001). Power systems harmonics: Computer Modelling and Analysis, John Wiley & Sons, Ltd, New York
- [5] Arrillaga, J., Watson, N. R., Chen S. (2000). Power system quality assessment, John Wiley & Sons, Ltd, Chichester
- [6] Baggini, A. (2008). Handbook of Power Quality, John Wiley & Sons, Ltd, Chichester

- [7] Belan, A., Eleschova, Z., Smola, M. (2005): Resonance Overvoltages in Electric Power Networks. Proceeding of International Scientific Conference „2005 IEEE St. Petersburg PowerTech“. St. Petersburg, Russia 2005. ISBN 5-93208-034-0, pp. 465
- [8] Bollen, M. (1999). Understanding Power Quality Problems: Voltage Sags and Interruptions, Wiley-IEEE Press
- [9] Chapman, D. (2001). Harmonics – causes and effects, Leonardo Power Quality Application Guide, Part 3.1
- [10] Dugan, R.; McGranaghan, M. F.; Beaty, H. W. (1996). Electrical Power Systems Quality, McGraw-Hill, New York
- [11] Eleschova, Z., Belan, A., Mucha, M. (2006): Synchronous Generator with a Salient Pole Rotor – Source of Harmonic Distortion. WSEAS Transactions on Power Systems, ISSN 1790-5060. Issue 7, Volume 1., pp. 1196-1201
- [12] Onaygil, S., Guler, O., Erkin E., Saygin, H. (2005): Energy Efficient Lighting by Compact Fluorescent Lamps (CFLs) at the Residences, Leon'05, CIE Midterm Meeting and International Lighting Congress, 12-21 May, Leon, Spain
- [13] Sankaran, C. (2002). Power Quality, CRC press
- [14] Sokansky, K., Novak, T., Blaha, Z. (2009): Assessment of parameters of lights for public lighting. 10th International Scientific Conference “Electric Power Engineering”, May 12-14, 2009 Kouty nad Desnou, Czech Republic. pp. 194-196
- [15] Sokansky, K., Novak, T. (2008): Energy savings in public lighting. Przegląd Elektrotechniczny, Volume 84, Issue 8, pp. 72-74
- [16] Szathmary, P. (2003). Power quality, PRO s.r.o., Banska Bystrica
- [17] Gasparovsky, D.; Herdova, B. (2006) Public lighting reconstruction, Typhoon s.r.o and Energy Centre Bratislava, Bratislava

IntechOpen

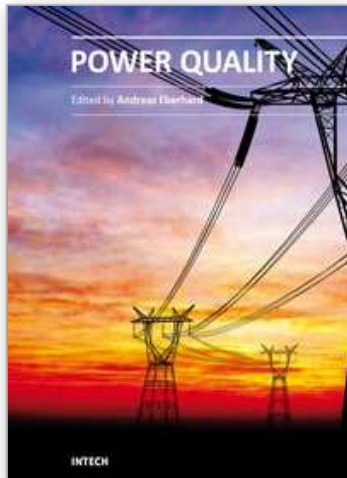

Power Quality

Edited by Mr Andreas Eberhard

ISBN 978-953-307-180-0

Hard cover, 362 pages

Publisher InTech

Published online 11, April, 2011

Published in print edition April, 2011

Almost all experts are in agreement - although we will see an improvement in metering and control of the power flow, Power Quality will suffer. This book will give an overview of how power quality might impact our lives today and tomorrow, introduce new ways to monitor power quality and inform us about interesting possibilities to mitigate power quality problems.

How to reference

In order to correctly reference this scholarly work, feel free to copy and paste the following:

Peter Janiga and Dionyz Gasparovsky (2011). Power Quality in Public Lighting Installations, Power Quality, Mr Andreas Eberhard (Ed.), ISBN: 978-953-307-180-0, InTech, Available from:

<http://www.intechopen.com/books/power-quality/power-quality-in-public-lighting-installations>

INTECH

open science | open minds

InTech Europe

University Campus STeP Ri
Slavka Krautzeka 83/A
51000 Rijeka, Croatia
Phone: +385 (51) 770 447
Fax: +385 (51) 686 166
www.intechopen.com

InTech China

Unit 405, Office Block, Hotel Equatorial Shanghai
No.65, Yan An Road (West), Shanghai, 200040, China
中国上海市延安西路65号上海国际贵都大饭店办公楼405单元
Phone: +86-21-62489820
Fax: +86-21-62489821

© 2011 The Author(s). Licensee IntechOpen. This chapter is distributed under the terms of the [Creative Commons Attribution-NonCommercial-ShareAlike-3.0 License](#), which permits use, distribution and reproduction for non-commercial purposes, provided the original is properly cited and derivative works building on this content are distributed under the same license.

IntechOpen

IntechOpen