

# We are IntechOpen, the world's leading publisher of Open Access books Built by scientists, for scientists

**4,800**

Open access books available

**122,000**

International authors and editors

**135M**

Downloads

Our authors are among the

**154**

Countries delivered to

**TOP 1%**

most cited scientists

**12.2%**

Contributors from top 500 universities



**WEB OF SCIENCE™**

Selection of our books indexed in the Book Citation Index  
in Web of Science™ Core Collection (BKCI)

Interested in publishing with us?  
Contact [book.department@intechopen.com](mailto:book.department@intechopen.com)

Numbers displayed above are based on latest data collected.

For more information visit [www.intechopen.com](http://www.intechopen.com)



# Power Quality Control in Wind/Fuel Cell/Battery/Hydrogen Electrolyzer Hybrid Micro-grid Power System

Xiangjun Li, Dong Hui, Xiaokang Lai and Tao Yan  
*Electrical Engineering and New Material Department  
China Electric Power Research Institute  
15 Xiaoying East Road, Qinghe. Beijing 100192  
P.R.China*

## 1. Introduction

Generally, such as bio-fuels, wind, solar, small hydropower, marine and geothermal energy, etc. have been defined as new renewable energy. Photovoltaic and wind power generation have been in rapid growth, but they have characteristics of randomness, intermittent, uncontrollable. Although the idea of effective renewable energy use as a means of coping with environmental and resource problems, especially of reducing CO<sub>2</sub> emissions, is globally attractive, inappropriate application of distributed renewable power generation systems can be a cause of insecure power supply. That is, the widespread use of various kinds of distributed renewable power sources which would impact the quality of the power supply within a micro-grid power system, causing many control problems (Li et al., 2008).

Micro-grid is one such system, consisting of distributed generators, loads, power storage devices and heat recovery equipment, among other components. The main advantages of the micro-grid system are that (1) it can be operated independently from conventional utility grids, (2) it can make use of power and heat sources collectively, (3) it can be interconnected to the utility grids at one point (Lasseter et al., 2002; Lasseter & Paigi., 2004; Li et al., 2008).

A micro-grid system (see Fig. 1) comprised of a control and monitoring system, a housing load, a 1MW load-controllable electrolyzer system to manufacture hydrogen, a hydrogen tank and renewable-energy-utilizing generators such as 3MW wind power generation system (WPGS), 500kW proton exchange membrane fuel cell (FC), 1MWh battery energy storage system (BESS), and others, is considered in this chapter. The power supply-demand balance control of the micro-grid system is performed by the control and monitoring system through a Control Area Network (CAN) composed communication network. Moreover, the electricity of electrolyzer system is supplied mainly by the wind power energy source and the hydrogen produced by the electrolyzer system is stored in the hydrogen tank to be converted back to electricity in the proton exchange membrane fuel cells. The wind power is considered as primary source in this chapter. However, when the lack of power supply from renewable power sources is occurred, the missing power will be provided via utility grid (Li et al., 2007; Li et al., 2008).

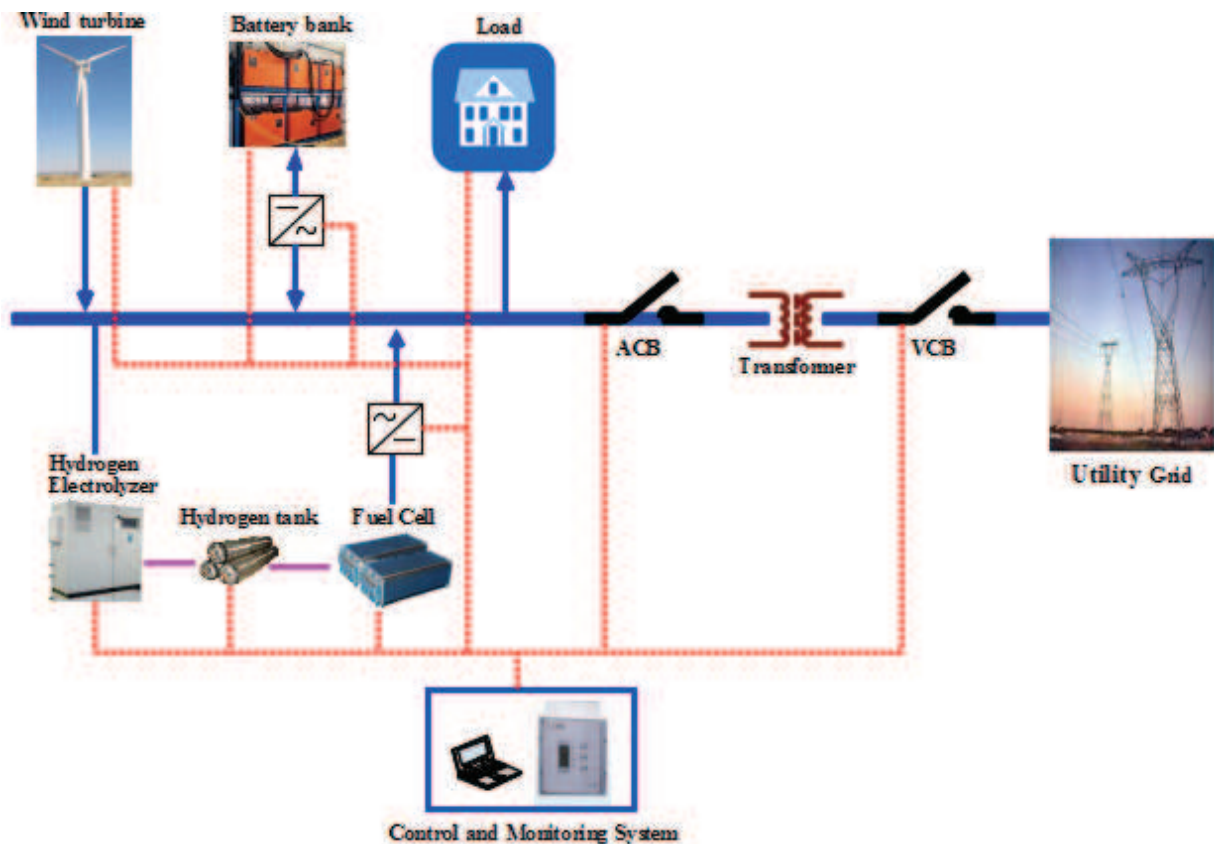

Fig. 1. System configuration of micro-grid network

Wind power and photovoltaic generators have the disadvantage of an unstable power output. Therefore, in these kinds of hybrid power systems, a sudden real power imbalance or a large frequency fluctuation can easily occur. Moreover, when the type of power line designed to be interconnected to a utility grid is 380V three-phase AC line, applying a DC or AC source to the AC grid would lead to harmonic distortion of voltages and currents. The harmonics resulting mainly from the operation of power electronic systems (e.g. converters) have ignored in this study (Hingorani & Gyugyi, 2000; Li et al., 2008). Here, we have studied the frequency fluctuations resulting mainly from real power imbalances and applied the BESS and electrolyzer system to smooth the power fluctuation of micro-grid power system.

The so-called hydrogen economy is a long-term project that can be defined as an effort to change the current energy system to one which attempts to combine the cleanliness of hydrogen as an energy carrier with the efficiency of fuel cells as devices to transform energy into electricity and heat. As an energy carrier, hydrogen must be obtained from other energy sources, in processes that, at least in the long term, avoid or minimize CO<sub>2</sub> emissions (Gregorio & Teresa, 2007; Li et al., 2008). Electrolyzer system fed by renewable energies (such as photovoltaic solar panels or windmills) or biomass reformers is the distributed resource of interest to generate hydrogen. Moreover, the electrolyzer system can offer flexible controllability functions to compensate for system's real power imbalances (Li et al., 2007; Li et al., 2008). In (Li et al., 2008), with regard to such a capability, a combination of a micro turbine and the fuel cell and electrolyzer hybrid system to deal with real-time frequency fluctuations and sudden real power imbalances has been proposed. In this chapter, a fuel cell and electrolyzer hybrid system is also considered to deal with real-time real power imbalances.

In addition, energy storage technology would resolve above-mentioned random fluctuation issues of the new energy power generation. It can achieve a smooth power output of renewable power sources. Therefore, a flexible energy storage system consisting of the battery, rectifier and inverter devices is getting more and more attention. For example, an integration of battery energy storage system with wind power generation system can provide flexible energy management solution for improving power quality of the renewable energy hybrid power generation system (Li et al., 2010b, 2010c & 2010d). Moreover, with the rapid development of batteries, as one possible means, BESS will be utilized to smooth the output fluctuation of renewable energy such as PV, WP and FC (Yoshimoto et al., 2006; Rajendra Prasad & Natarajan, 2006; Senjyu et al., 2008; Muyeen et al., 2009; Lalouni et al., 2009; Teleke et al., 2009; Li et al., 2009; Khalid & Savkin, 2010; Li et al., 2010b-d). However, if there is no control method to regulate the outputting-level of wind power and the charging-level of BESS effectively, a large energy storage capacity is necessary. Therefore, this chapter will introduce a fuzzy-logic based power conditioning strategy of the load-controllable electrolyzer system to deal with real-time fluctuations of micro-grid's real power imbalance and system frequency. Meanwhile, the power of fuel cell system and that of BESS will be adaptively changed according to the feedback values of battery state of charge (SOC) and micro-grid's real power imbalance.

This chapter is organized as follows. Section 2 presents modeling of each power sources in micro-grid power system. That is, (1) modeling of fuel cell and electrolyzer system; (2) modeling of battery energy storage system; (3) modeling of wind power generation system; (4) modeling of system load, etc. will be included, respectively. Section 3 presents an objective function for frequency control in the micro-grid system. Section 4 presents a fuzzy control strategy of hydrogen electrolyzer system based on battery SOC and real power imbalance to expand the micro-grid system's ability to solve power quality issues. Section 5 discusses simulation results based on the considered power system model. Section 6 is the conclusions.

## 2. Modeling of each power sources

### 2.1 Modeling of fuel cell and electrolyzer system

Here, the power output characteristics of fuel cell and electrolyzer systems are linearized by the following first-order transfer functions based on different time constants,  $T_{FC}$  and  $T_{ES}$  in reference to the operation of a battery-energy-storage facility, as shown in (Kottick et al., 1993, Li et al., 2008). As a result, the dynamic behaviors of fuel cell and electrolyzer systems can be formulated as follows.

$$P_{FC} = \frac{1}{T_{FC}s + 1} P_{FC}^{CMD} \quad (1)$$

$$P_{ES} = \frac{1}{T_{ES}s + 1} P_{ES}^{CMD} \quad (2)$$

### 2.2 Modeling of battery energy storage system

An 100KW lithium-ion BESS has been modeled in reference to the  $R_{int}$  model presented in (Li et al., 2009). In general we know that  $I_{bat}$  and  $V_{bat}$  can be expressed as Eqs. (3) and (4),

respectively, when the battery power consumption is  $P$  W. Moreover, as shown in Eqs.(5) and (6),  $V_{ocv}$  and  $R_{bat}^{int}$  are determined by using look-up tables based on experimental data presented in Figs. 2 and 3. The battery SOC is calculated by using Eqs.(7) and (8), and the  $\eta$  is calculated depend on battery charge/discharge status. The model of BESS based on Matlab/Simulink is shwon in Fig.4 (Li et al., 2009 & 2010a). In this chapter, 1MWh BESS is designed by integrating ten 100kWh BESSs in parallel to minimize real power imbalance in micro-grid power system.

$$I_{bat} = \frac{V_{ocv} - \sqrt{V_{ocv}^2 - 4R_{bat}^{int}P}}{2R_{bat}^{int}} \quad (3)$$

$$V_{bat} = V_{ocv} - R_{bat}^{int} I_{bat} \quad (4)$$

Where

$$V_{ocv} = f_1(SOC) \quad (5)$$

$$R_{bat}^{int} = \begin{cases} R_{ch} = f_2(SOC) & \text{charging} \\ R_{dis} = f_3(SOC) & \text{discharging} \end{cases} \quad (6)$$

$$SOC = SOC_{ini} - \int \frac{\eta I_{bat}}{Q} dt \quad (7)$$

$$\eta = \begin{cases} \eta_{ch} = \frac{V_{ocv}}{V_{ocv} - I_{bat}R_{ch}} & \text{charging} \\ \eta_{dis} = \frac{V_{ocv} - I_{bat}R_{dis}}{V_{ocv}} & \text{discharging} \end{cases} \quad (8)$$

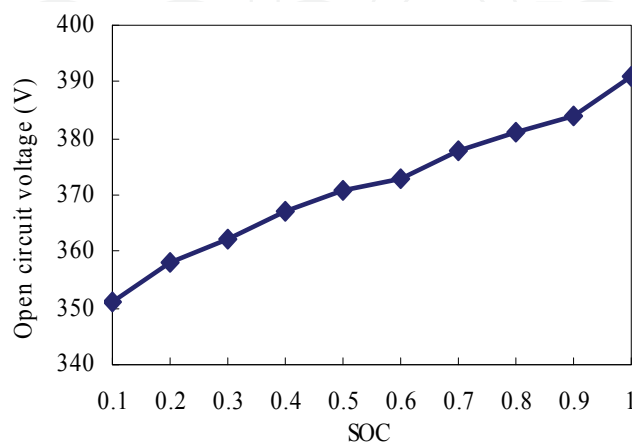

Fig. 2. Characteristic of open circuit voltage via battery

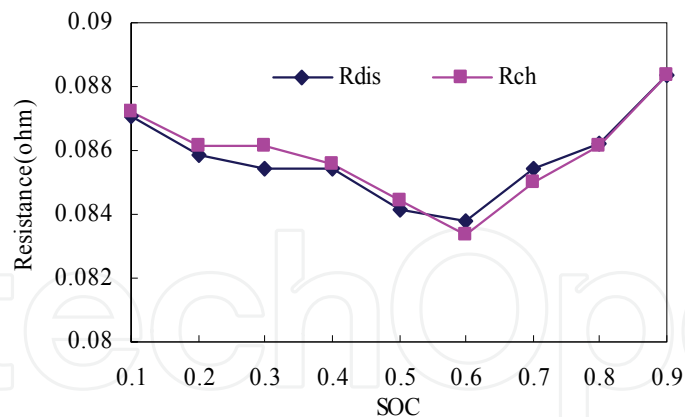

Fig. 3. Interior resistance via battery SOC

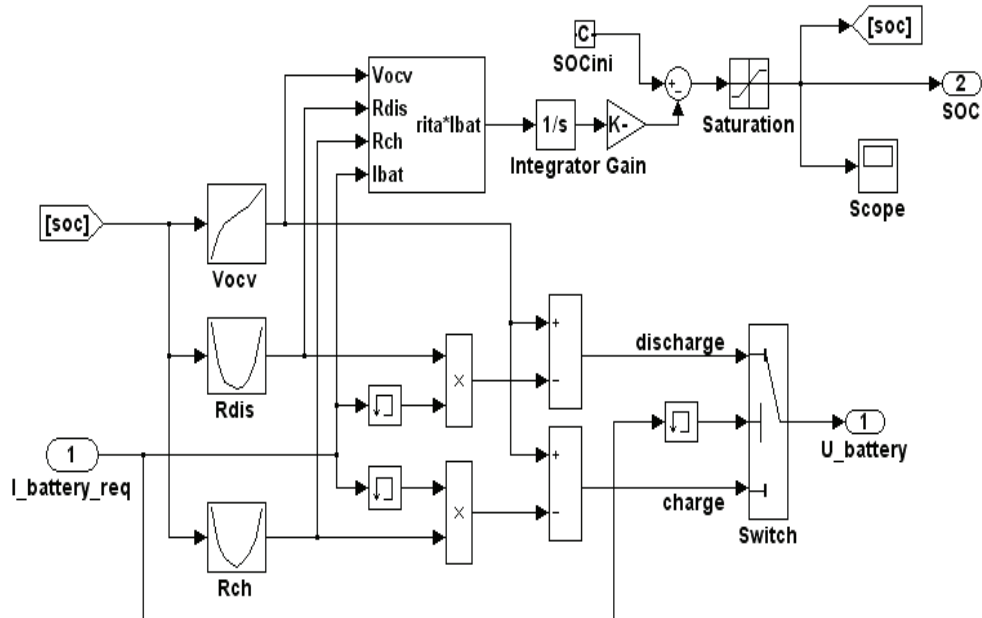

Fig. 4. Model of BESS

### 2.3 Modeling of wind power generation system

The extracted power from the wind can be expressed as follows:

$$P_w = 0.5\rho\pi R^2V_w^3C_p(\lambda, \beta) \tag{9}$$

Where,  $P_w$  is the power from wind,  $\rho$  is air density [kg/m<sup>3</sup>],  $R$  is blade radius[m],  $V_w$  is the wind speed[m/s] and  $C_p$  is the power coefficient which is a function of both tip speed ratio  $\lambda$  and blade pitch angle  $\beta$ [deg].

$$C_p(\lambda, \beta) = 0.22 \left( \frac{16}{\lambda_i} - 0.4\beta - 5 \right) e^{-\frac{12.5}{\lambda_i}} \tag{10}$$

where  $\lambda_i$  is given by

$$\frac{1}{\lambda_i} = \frac{1}{\lambda + 0.08\beta} - \frac{0.035}{\beta^3 + 1} \tag{11}$$

The WPGS modeled by MATLAB/SIMULINK is shown in Fig. 5. In this chapter, the wind speed is modeled by multiplying a random speed fluctuation derived from the white noise block in MATLAB/SIMULINK as shown in Fig. 6. As a result, wind power output profile used in this chapter can be calculated as shown in Fig. 7 (Li et al., 2010b & 2010c).

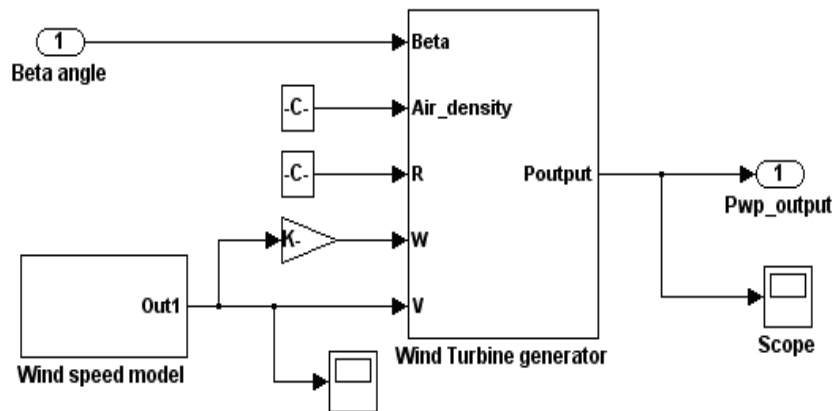

Fig. 5. Model of WPGS using MATLAB/SIMULINK

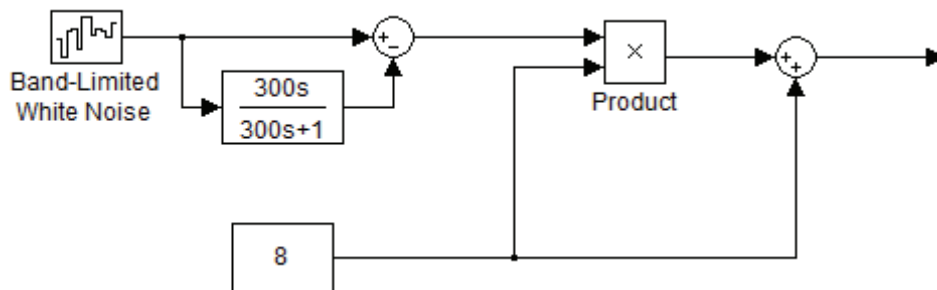

Fig. 6. Wind speed model using MATLAB/SIMULINK

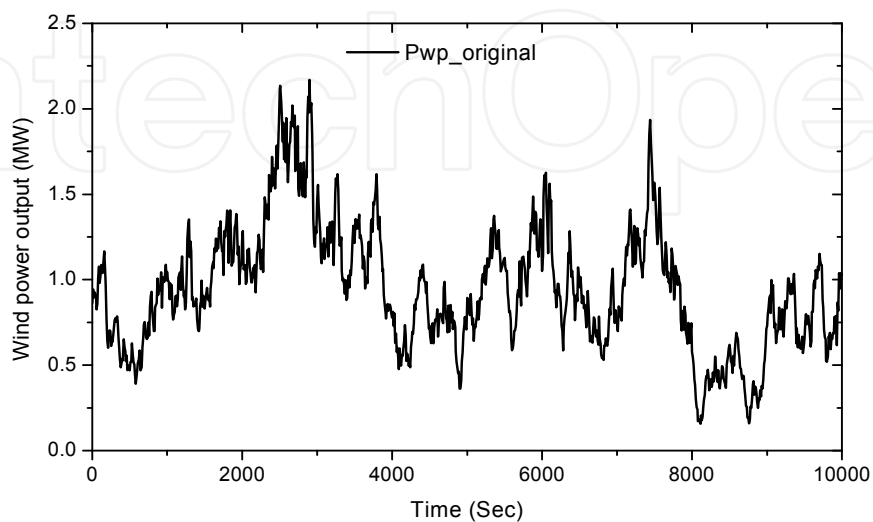

Fig. 7. Wind power output of micro-grid power system

### 2.4 Modeling of system load

The input power variability of micro-grid system load is determined by considering the deviations from the initial value. And the following standard deviation,  $dP_{Load}$  is multiplied by the random output fluctuation derived from the white noise block in MATLAB/SIMULINK in order to simulate the real-time random power fluctuation on the load side. The deviation for the system load is simulated close to an actual change wave by the following functions as presented in (Matsubara et al., 2005; Shinji et al., 2006; Li et al., 2007; Li et al., 2008).

$$dP_{Load} = 0.6\sqrt{P_{Load}} \tag{12}$$

That, the system load power is defined as follows.

$$P_{Load} = P_{Load}^{ini} + dP_{Load} \tag{13}$$

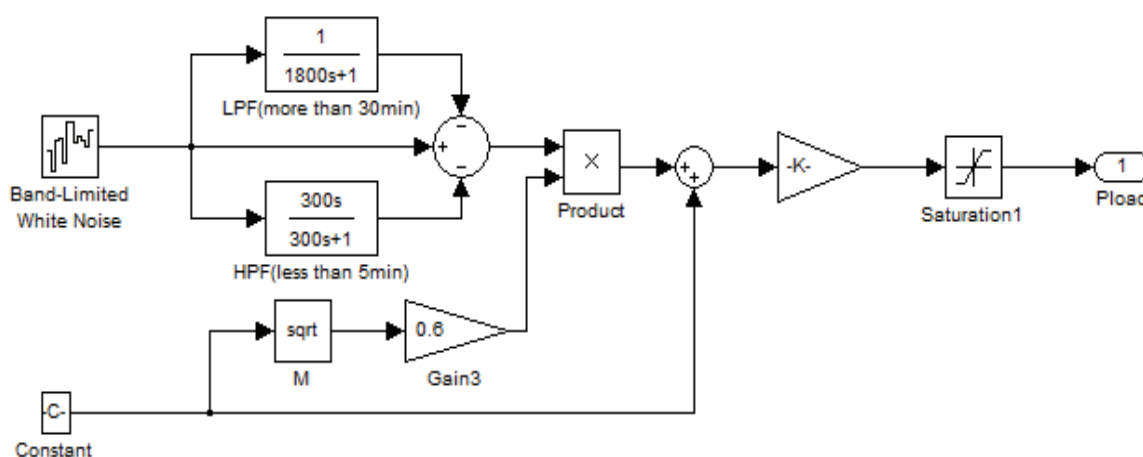

Fig. 8. Load model using MATLAB/SIMULINK

### 3. Problem formulation

Since frequency fluctuation,  $\Delta f$ , is effected mainly by the fluctuation of real power, power quality problems threatening frequency stability can be solved or avoided by satisfying the real power supply-demand balance constraint in the micro-grid power system (Li et al., 2007; Li et al., 2008). Therefore, an objective function for frequency control in the micro-grid system is formulized as follows.

$$\Delta P = P_{FC} + P_{WP} + P_{BESS} - P_{Load} - P_{ES} \rightarrow 0 \tag{14}$$

subject to

$$P_{WP}^{min} \leq P_{WP} \leq P_{WP}^{max} \tag{15}$$

$$P_{FC}^{min} \leq P_{FC} \leq P_{FC}^{max} \tag{16}$$



$$P_{ES}^{\min} \leq P_{ES} \leq P_{ES}^{\max} \quad (17)$$

$$P_{BESS}^{\min} \leq P_{BESS} \leq P_{BESS}^{\max} \quad (18)$$

#### 4. Fuzzy control strategy of micro-grid power system

The battery energy storage system is the current attractive means of smoothing intermittent wind or solar power generation. Such battery, wind and/or solar power hybrid micro-grid power systems require a suitable control strategy that can effectively regulate fluctuant power output levels and battery state of charge (SOC); otherwise, an inconveniently and problematically large energy storage capacity is necessary.

Moreover, as above-mentioned, the power consumption of hydrogen electrolyzer system can be controlled in realtime. Therefore, to make full use of such response controllability, the power of electrolyzer system need to be increased in such a case that there is enough WP generation compared with system load in the micro-grid system. Otherwise, the power of electrolyzer system need to be decreased when there is less affluent WP generation compared with system load. These cases can be judged by calculating the difference between  $P_{WP}$  and  $P_{Load}$ .

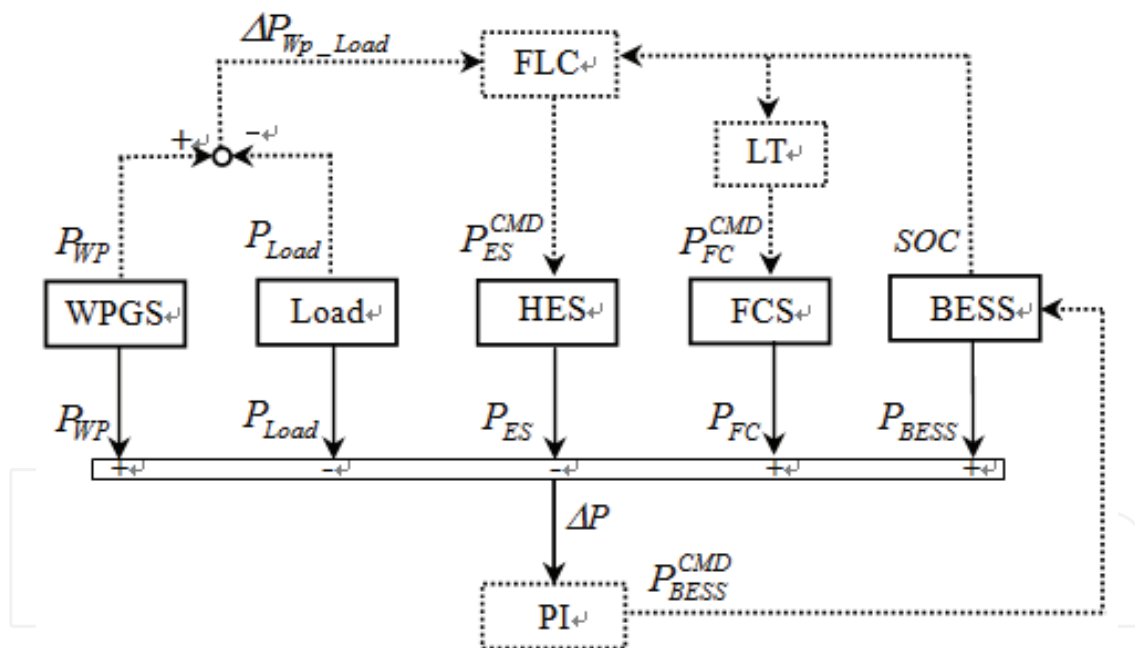

Fig. 9. Schematic diagram of proposed control strategy

For these considerations, in this chapter, a fuzzy logic controller is applied to adaptively regulate the power consumption of electrolyzer system and a PI controller is also introduced to minimize the real power imbalance  $\Delta P$  in micro-grid power system. That is, the Mamdani-type fuzzy logic controller, FLC, shown in Fig. 9, for which the two inputs are battery SOC and  $\Delta P_{WP\_Load}$  and the one output is  $P_{ES}^{FUZZY}$ , is proposed. And, the PI controller, for which input is  $\Delta P$  and output is  $P_{BESS}^{CMD}$ , is applied. Moreover, an one dimensional look up table (LT) block, shown in Fig.9, for which input is battery SOC and output is  $P_{FC}^{CMD}$  is also used to modify output power of FC timely based on battery

charging-level. So, the proposed method can enhance the minimizations of tie-line power and imbalance power levels for interconnected micro-grid power system and supervise the battery SOC to secure the charging-level of the BESS. The target power of BESS and that of ES can be determined by the following Eqs. (19)-(22).

$$P_{BESS}^{CMD} = \Delta P (K_p + K_i \int dt) \tag{19}$$

$$P_{ES}^{CMD} = P_{ES}^{FUZZY} = f(SOC, \Delta P_{WP\_Load}) \tag{20}$$

$$P_{FC}^{CMD} = f_{LT}(SOC) P_{FC}^{Initial} \tag{21}$$

Where,

$$SOC^{min} \leq SOC \leq SOC^{max} \tag{22}$$

Fuzzy membership function used in work is shown in Fig. 10. Fuzzy rule table for  $P_{ES}^{FUZZY}$  is shown in Table 1. For the PI controller as shown in Fig. 9, the gain values of  $K_P$  and  $K_I$ , to reduce  $\Delta P$ , are 1 and 10, respectively.

No	Logic of judgment rules
1	If SOC is <i>Big</i> & $\Delta P_{WP\_Load}$ is <i>Big</i> then $P_{ES}^{FUZZY}$ is <i>Big</i>
2	If SOC is <i>Medium</i> & $\Delta P_{WP\_Load}$ is <i>Big</i> then $P_{ES}^{FUZZY}$ is <i>Big</i>
3	If SOC is <i>Small</i> & $\Delta P_{WP\_Load}$ is <i>Big</i> then $P_{ES}^{FUZZY}$ is <i>Small</i>
4	If SOC is <i>Big</i> & $\Delta P_{WP\_Load}$ is <i>Medium</i> then $P_{ES}^{FUZZY}$ is <i>Medium</i>
5	If SOC is <i>Medium</i> & $\Delta P_{WP\_Load}$ is <i>Medium</i> then $P_{ES}^{FUZZY}$ is <i>Medium</i>
6	If SOC is <i>Small</i> & $\Delta P_{WP\_Load}$ is <i>Medium</i> then $P_{ES}^{FUZZY}$ is <i>Small</i>
7	If SOC is <i>Big</i> & $\Delta P_{WP\_Load}$ is <i>Small</i> then $P_{ES}^{FUZZY}$ is <i>Small</i>
8	If SOC is <i>Medium</i> & $\Delta P_{WP\_Load}$ is <i>Small</i> then $P_{ES}^{FUZZY}$ is <i>Small</i>
9	If SOC is <i>Small</i> & $\Delta P_{WP\_Load}$ is <i>Small</i> then $P_{ES}^{FUZZY}$ is <i>Small</i>

Table 1. Fuzzy rule table for  $P_{ES}^{FUZZY}$

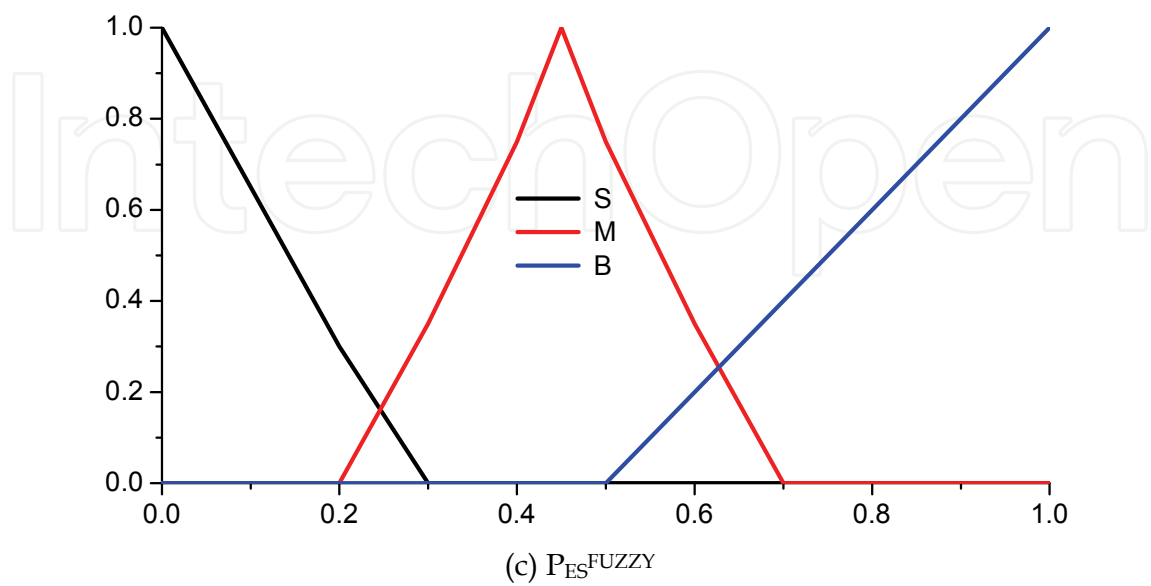
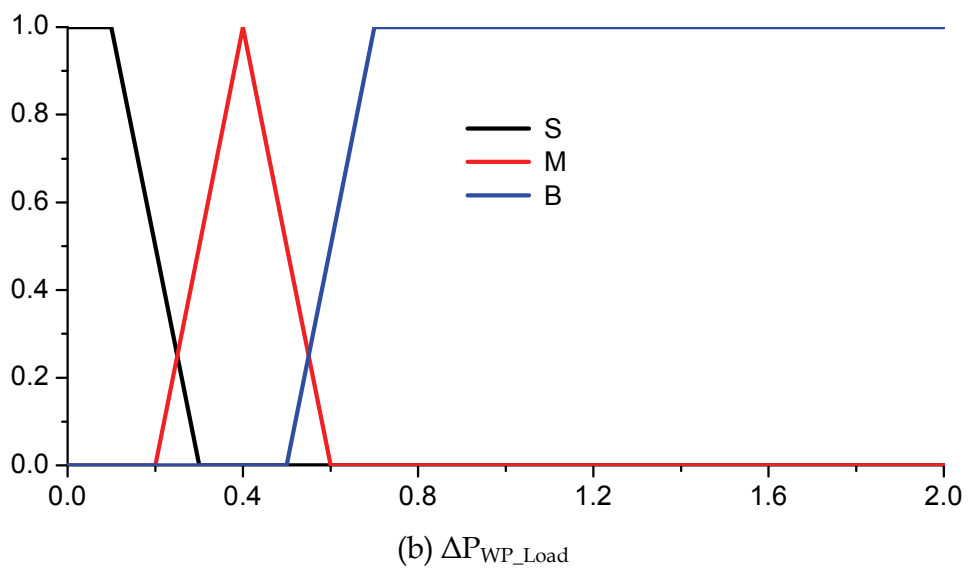
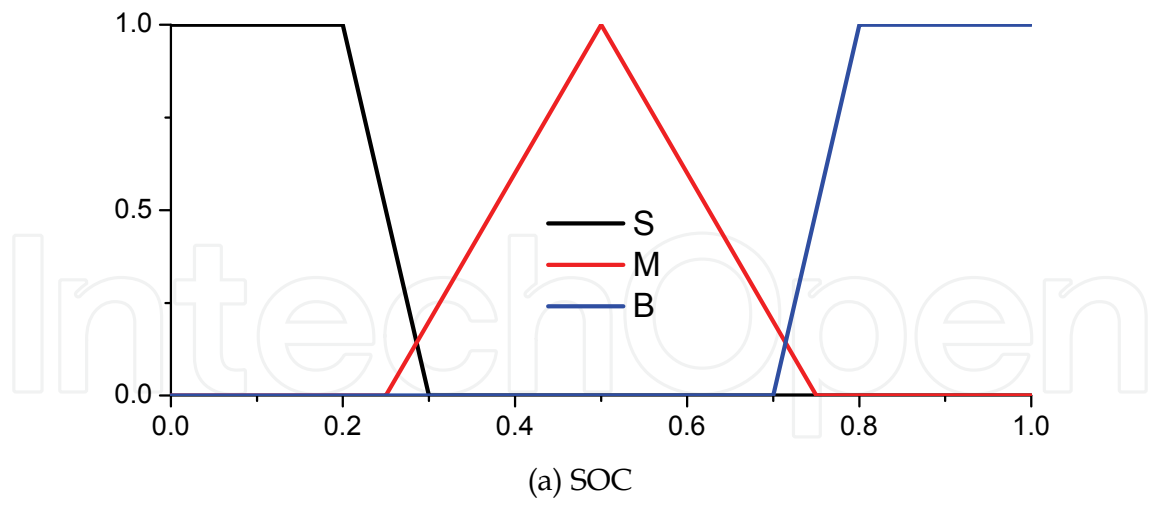

Fig. 10. Fuzzy membership function

## 5. Simulation results and discussion

The initial real power balance in the micro-grid is set to zero at the simulation starting point and the feasibility of the electrolyzer system control is examined over the course of 2000 seconds. The simulation results for islanding operation is presented as follows. The reference parameters of tie-line power and real power supply-demand imbalance are all set to zero. That is, in the case of interconnected operation with utility grid, the tie-line power flow target is set to zero. In the following, two cases for without/with fuzzy controller are discussed to illustrate the proposed fuzzy-logic-based control strategy. It is noted that the initial SOC of BESS is all set to 80% for the two cases, and the target power of electrolyzer system is set to a fixed value of 0.3MW in the case that fuzzy controller is ignored.

Figs. 11 and 12 show the power profiles of system load and WPGS. Figs. 13 and 14 show the power and SOC profiles of BESS, respectively. It is obviously apparent that the battery SOC is effectively controlled by introducing SOC based fuzzy controller. Otherwise, added capacity of BESS or additional operation is required. Figs. 15 and 16 show power profiles of electrolyzer and fuel cell systems with/without fuzzy controller. Real power imbalance profile in micro-grid system is shown in Fig. 17. Comparing Figs. 15, 16 and 17 shows that the proposed control method controls the power of the electrolyzer system and that of the fuel cell system to relax the wind power fluctuations and match the real power balance. Moreover, as shown in these figures, the result is that the real power imbalance is suitably controlled by the adaptive control of the electrolyzer system, and the power quality of frequency fluctuation is accordingly improved by applying the proposed fuzzy controller.

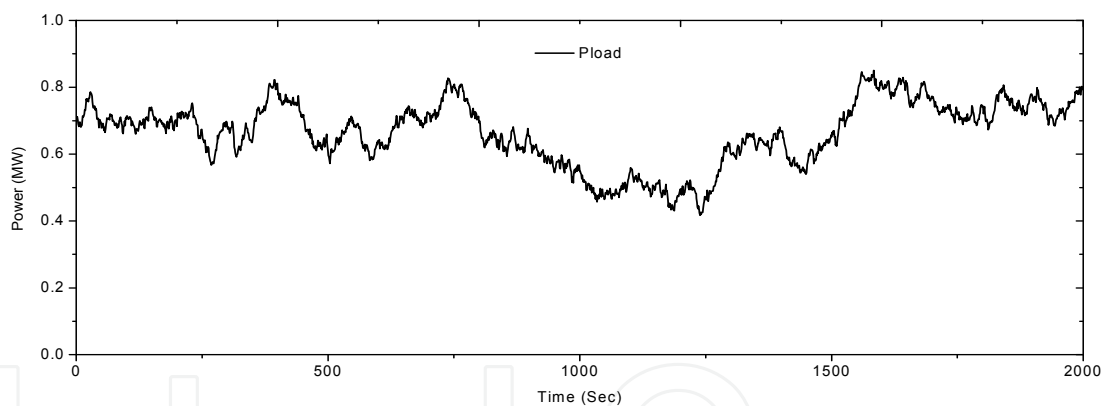

Fig. 11. Power profile of system load

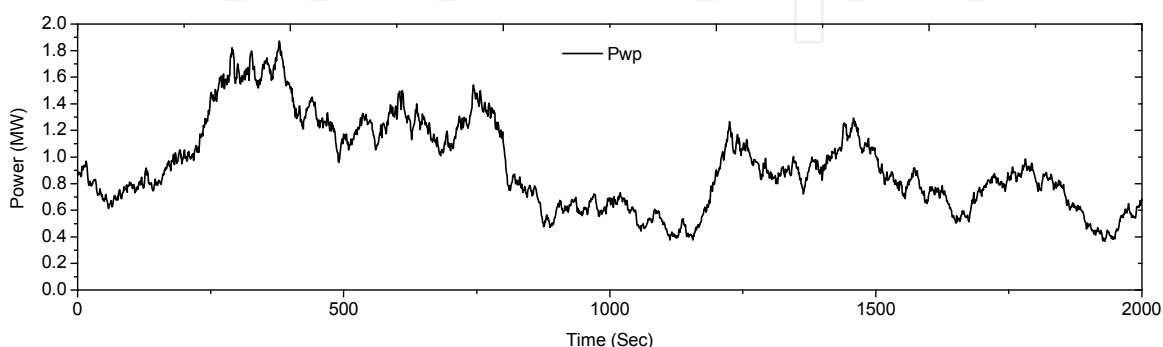
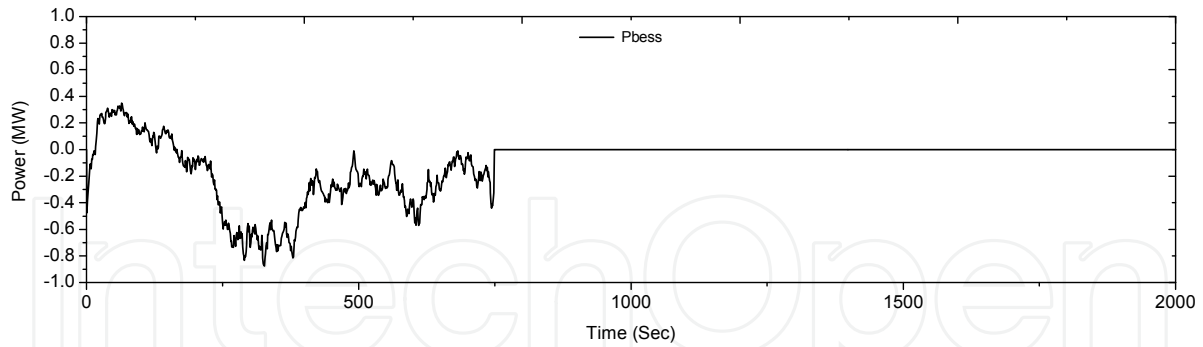
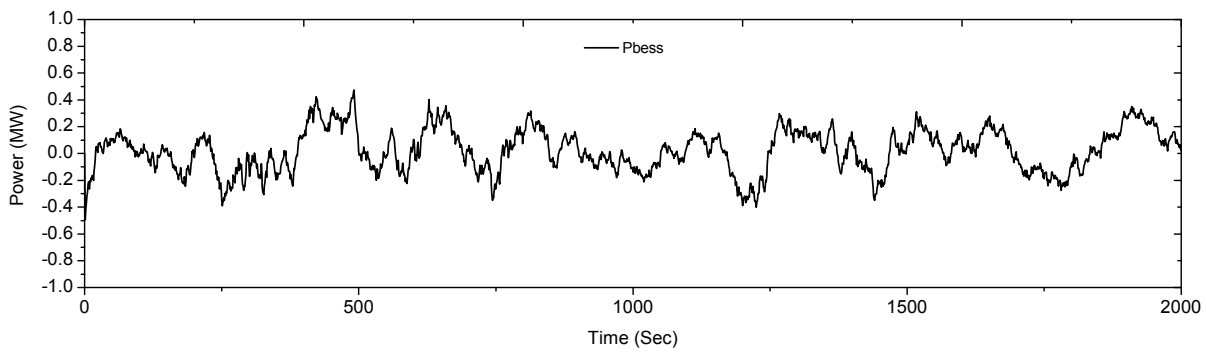

Fig. 12. Power profile of WPGS



(13-1) without fuzzy controller



(13-2) with fuzzy controller

Fig. 13. Power profiles of battery energy storage system with/without fuzzy controller

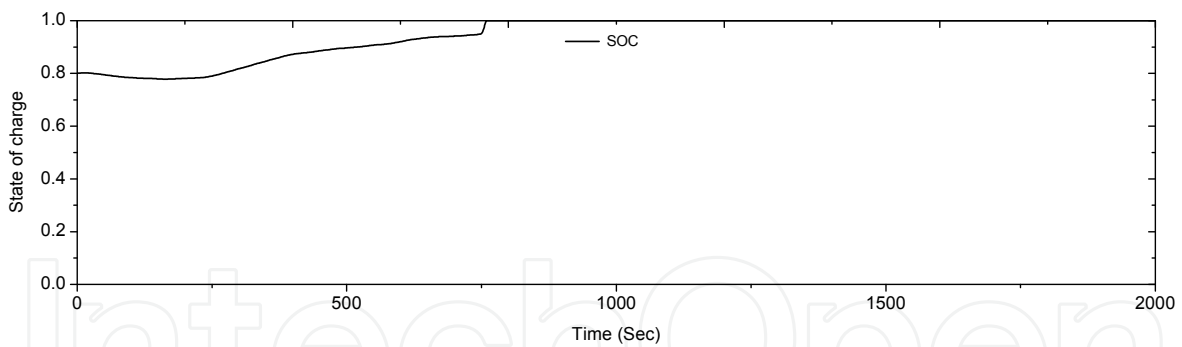

(14-1) without fuzzy controller

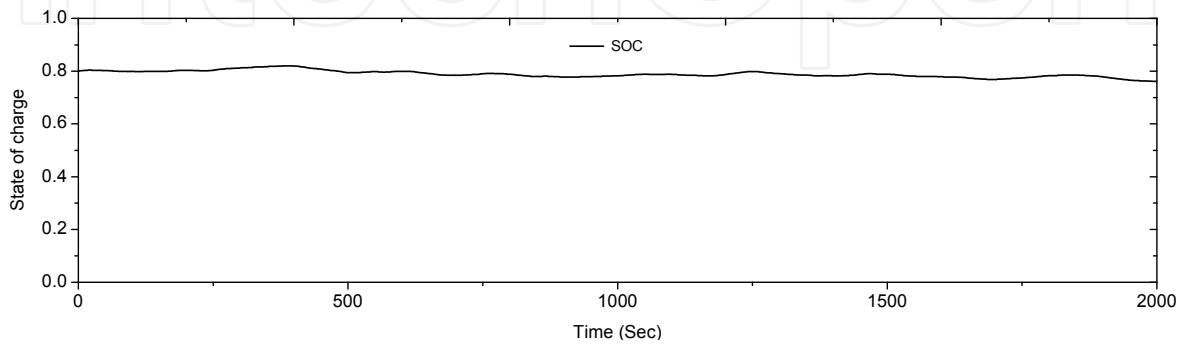

(14-2) with fuzzy controller

Fig. 14. SOC profile of battery energy storage system with/without fuzzy control

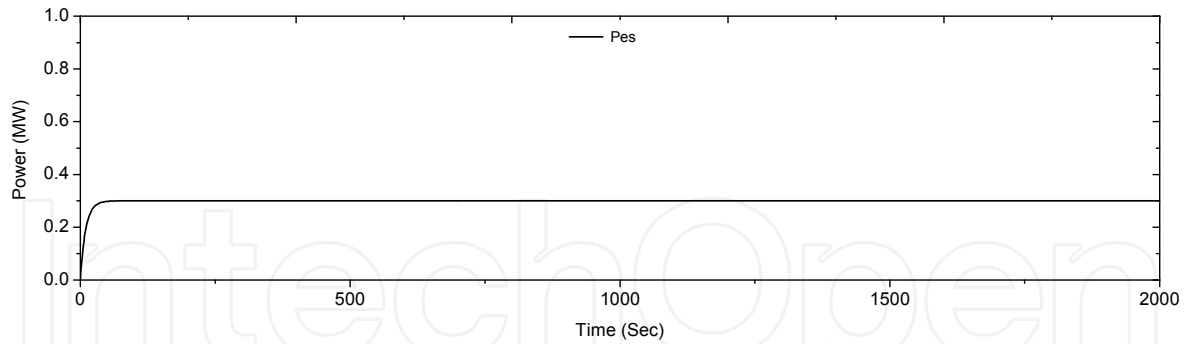

(15-1) without fuzzy controller

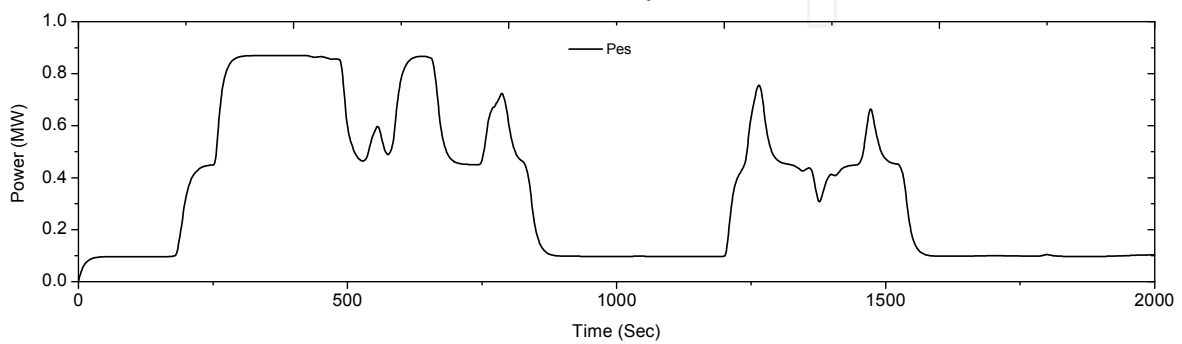

(15-2) with fuzzy controller

Fig. 15. Power profile of electrolyzer system with/without fuzzy controller

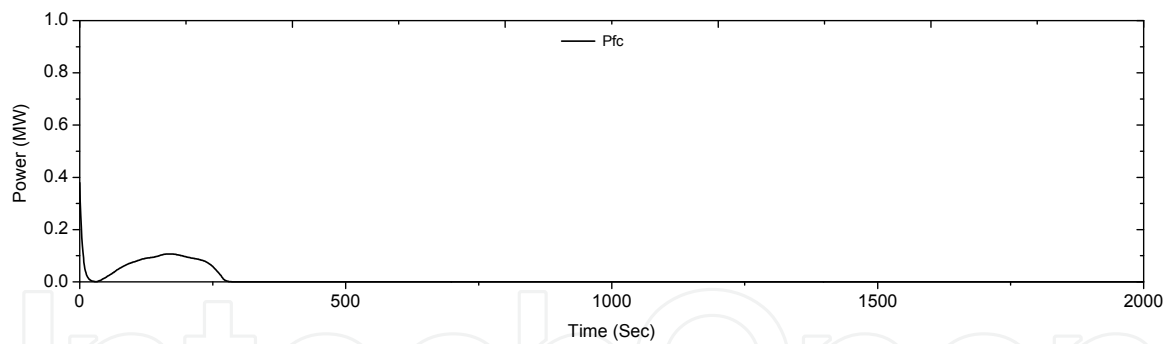

(16-1) without fuzzy controller

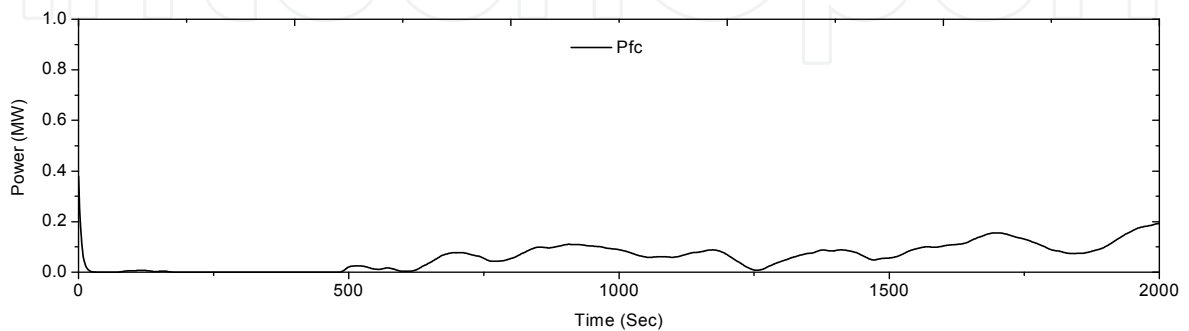

(16-2) with fuzzy controller

Fig. 16. Power profile of fuel cell system with/without fuzzy controller

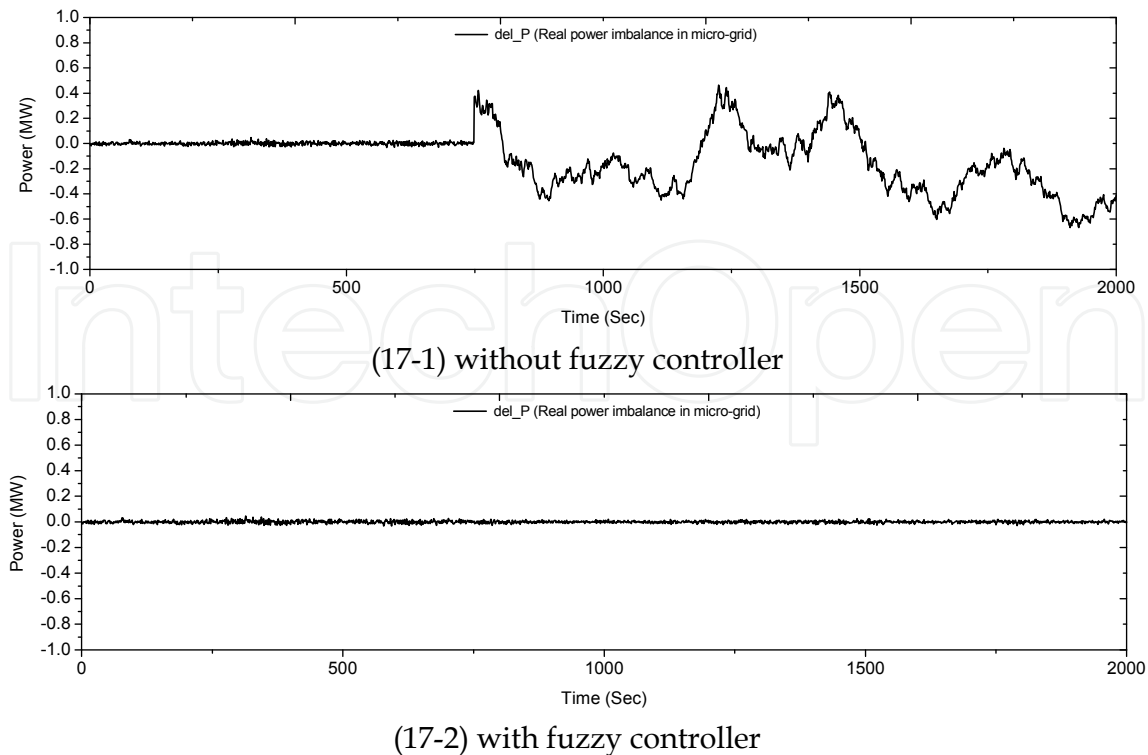

Fig. 17. Real power imbalance profile in micro-grid system with/without fuzzy controller

## 7. Conclusion

In this chapter, an electrolyzer system's dynamic control method, which secures a real power balance and enhances the operational capability to handle frequency fluctuation in multiple renewable energy hybrid micro-grid power system, is proposed. The PI and fuzzy controllers are introduced to compensate the power fluctuations in micro-grid power system. The effects of their usages are also explored through simulation experiment. Moreover, the fluctuation of real power imbalance under the islanding operational mode is discussed in demonstrating the effectiveness of the proposed control strategy. It is concretely shown that a power quality improvement for frequency can be achieved by actively utilizing battery energy storage system and load-controllable electrolyzer system. Moreover, the battery SOC can be managed within a specified target region. Therefore, the proposed control scheme helps to solve power quality issue resulting from real power imbalance fluctuations.

## 8. Acknowledgements

This work is supported by the National Program on Key Basic Research Project (973 Program) (Grant No. 2010CB227206) and by the Scientific Research Foundation for the Returned Overseas Chinese Scholars, State Education Ministry (Grant No. 20091001).

## 9. References

N. G. Hingorani & L. Gyugyi, (2000) Understanding FACTS-Concepts and Technology of Flexible AC Transmission Systems, New York, IEEE Press.

- R. H. Lasseter, A. Akhil, C. Marnay, J. Stephens, J. Dagle, R. Guttromson, A. S. Meliopoulos, R. Yinger & J. Eto, (2002) Integration of Distributed Energy Resources-The CERTS MicroGrid Concept, *CERTS white paper*, Apr. 2002
- R. H. Lasseter & P. Paigi, (2004) Microgrid: A Conceptual Solution, in *Proc. 35th Annu. Conf. IEEE PESC'04*, pp.4285-4290, 2004
- Gregorio Marban. & Teresa Valdes-Solis, (2007). Towards the hydrogen economy? *International Journal of Hydrogen Energy* 32, pp.1625-1637, 2007
- M. Matsubara, G. Fujita, T. Shinji, T. Sekine, A. Akisawa, T. Kashiwagi & R. Yokoyama, (2005) Supply and Demand Control of Dispersed Type Power Sources in Micro Grid, in *Proc. 13th Int. Conf. ISAP'05*, pp.67-72, 2005
- T. Shinji, T. Sekine, A. Akisawa, T. Kashiwagi, G. Fujita, M. Matsubara, (2006) Discussion on Reduction of Power Fluctuation by Distributed Generation in Micro Grid, *IEEJ Trans. PE. Vol.126. No.1*, 2006. (In Japanese)
- K. Yoshimoto, T. Nanahara, G. Koshimizu, (2006) New Control Method for Regulating State-of-Charge of a Battery in Hybrid Wind Power/Battery Energy Storage System, *IEEE Power Systems Conference and Exposition*, pp. 1244-1251, 2006.
- A. Rajendra Prasad & E. Natarajan (2006) Optimization of integrated photovoltaic-wind power generation systems with battery storage, *Energy*, Vol. 31, Issue 12, pp.1943-1954, Sep. 2006
- T.Senju, Y. Kikunaga, A.Yona, H. Sekine, A.Y. Saber & T. Funabashi, (2008) Coordinate control of wind turbine and battery in wind power generator system, *IEEE Power and Energy Society General Meeting-Conversion and Delivery of Electrical Energy in the 21st Century*, pp.1-7, Jul. 2008
- S.M. Mueen, Rion Takahashi, Toshiaki Murata, Junji Tamura & Mohd. Hasan Ali, (2009) Application of STATCOM/BESS for wind power smoothing and hydrogen generation, *Electric Power Systems Research*, Vol. 79, Issue 2, pp. 365-373, Feb. 2009
- S. Lalouni, D. Rekioua, T. Rekioua, E. Matagne, (2009) Fuzzy logic control of stand-alone photovoltaic system with battery storage, *Journal of Power Sources*, Vol. 193, Issue 2, pp. 899-907, Sep. 2009,
- Sercan Teleke, Mesut E. Baran, Alex Q. Huang, Subhashish Bhattacharya & Loren Anderson, (2009) Control Strategies for Battery Energy Storage for Wind Farm Dispatching, *IEEE Transactions on Energy Conversion*, Vol. 24, No. 3, pp. 725-732, Sep. 2009
- M. Khalid & A.V. Savkin, (2010) A model predictive control approach to the problem of wind power smoothing with controlled battery storage, *Renewable Energy*, Vol 35, Issue 7, pp. 1520-1526, Jul. 2010
- D. Kottick, M. Blau & D. Edelstein (1993) Battery Energy Storage for Frequency Regulation in an Island Power System, *IEEE Transactions on Energy Conversion*. Vol.8, pp.455-459, Sep. 1993
- Xiangjun Li, Yu-Jin Song & Soo-Bin Han, (2007). Study on Power Quality Control in Multiple Renewable Energy Hybrid MicroGrid System, *IEEE PowerTech2007*, pp.2000-2005, Jul. 2007
- Xiangjun Li, Yu-Jin Song, Soo-Bin Han, (2008) Frequency control in micro-grid power system combined with electrolyzer system and fuzzy PI controller, *Journal of Power Sources*, Vol.180, Issue 1, pp. 468-475, May. 2008



- Xiangjun Li, Liangfei Xu, Jianfeng Hua, Xinfan Lin, Jianqiu Li, Minggao Ouyang. (2009) Power management strategy for vehicular-applied hybrid fuel cell/battery power system, *Journal of Power Sources*, Vol. 191, Issue 2, pp. 542-549, Jun. 2009
- Xiangjun Li, Jianqiu Li, Liangfei Xu, Minggao Ouyang, Xuebing Han, Languang Lu, Chengtao Lin. (2010a) On-line management of lithium-ion battery based on time-triggered controller area network for fuel cell hybrid vehicle applications, *Journal of Power Sources*, Vol. 195, Issue 10, pp.3338-3343, May 2010
- Xiangjun Li, Dong Hui, Xiaokang Lai, Minggao Ouyang, Yong Min. (2010b) Fuzzy logic based coordinated controller for wind/battery/IDSMS hybrid micro-grid power system, *The 2nd International Conference on Computer Engineering and Technology (ICCET2010)*, Vol. 4, pp. 263-267, Chengdu, Apr. 2010.
- Xiangjun Li, Dong Hui, Xiaokang Lai, Minggao Ouyang. (2010c) Control Strategy of Wind Power Output by Pitch Angle Control using Fuzzy Logic, *IEEE International Symposium on Industrial Electronics (ISIE2010)*, pp.120-124, Bari, Jul. 2010.
- Xiangjun Li, Dong Hui, Li Wu, Xiaokang Lai. (2010d) Control Strategy of Battery State of Charge for Wind/Battery Hybrid Power System, *IEEE International Symposium on Industrial Electronics (ISIE2010)*, pp.2723-2726, Bari, Jul. 2010.

IntechOpen



## **Applications and Experiences of Quality Control**

Edited by Prof. Ognyan Ivanov

ISBN 978-953-307-236-4

Hard cover, 704 pages

**Publisher** InTech

**Published online** 26, April, 2011

**Published in print edition** April, 2011

The rich palette of topics set out in this book provides a sufficiently broad overview of the developments in the field of quality control. By providing detailed information on various aspects of quality control, this book can serve as a basis for starting interdisciplinary cooperation, which has increasingly become an integral part of scientific and applied research.

### **How to reference**

In order to correctly reference this scholarly work, feel free to copy and paste the following:

Xiangjun Li, Dong Hui, Xiaokang Lai and Tao Yan (2011). Power Quality Control in Wind/Fuel Cell/Battery/Hydrogen Electrolyzer Hybrid Micro-grid Power System, Applications and Experiences of Quality Control, Prof. Ognyan Ivanov (Ed.), ISBN: 978-953-307-236-4, InTech, Available from: <http://www.intechopen.com/books/applications-and-experiences-of-quality-control/power-quality-control-in-wind-fuel-cell-battery-hydrogen-electrolyzer-hybrid-micro-grid-power-system>

**INTECH**  
open science | open minds

### **InTech Europe**

University Campus STeP Ri  
Slavka Krautzeka 83/A  
51000 Rijeka, Croatia  
Phone: +385 (51) 770 447  
Fax: +385 (51) 686 166  
[www.intechopen.com](http://www.intechopen.com)

### **InTech China**

Unit 405, Office Block, Hotel Equatorial Shanghai  
No.65, Yan An Road (West), Shanghai, 200040, China  
中国上海市延安西路65号上海国际贵都大饭店办公楼405单元  
Phone: +86-21-62489820  
Fax: +86-21-62489821

© 2011 The Author(s). Licensee IntechOpen. This chapter is distributed under the terms of the [Creative Commons Attribution-NonCommercial-ShareAlike-3.0 License](#), which permits use, distribution and reproduction for non-commercial purposes, provided the original is properly cited and derivative works building on this content are distributed under the same license.

IntechOpen

IntechOpen