

We are IntechOpen, the world's leading publisher of Open Access books Built by scientists, for scientists

4,800

Open access books available

122,000

International authors and editors

135M

Downloads

Our authors are among the

154

Countries delivered to

TOP 1%

most cited scientists

12.2%

Contributors from top 500 universities



WEB OF SCIENCE™

Selection of our books indexed in the Book Citation Index
in Web of Science™ Core Collection (BKCI)

Interested in publishing with us?
Contact book.department@intechopen.com

Numbers displayed above are based on latest data collected.

For more information visit www.intechopen.com



Application of ANN to Real and Reactive Power Allocation Scheme

S.N. Khalid, M.W. Mustafa, H. Shareef and A. Khairuddin
*Universiti Teknologi Malaysia
Malaysia*

1. Introduction

This chapter describes the implementation of ANN for real and reactive power transfer allocation. The 25 bus equivalent power system of south Malaysia region and IEEE 118 bus system are used to demonstrate the applicability of the ANN output compared to that of the Modified Nodal Equations (MNE) which is used as trainers for real and reactive power allocation. The basic idea is to use supervised learning paradigm to train the ANN. Then the descriptions of inputs and outputs of the training data for the ANN are easily obtained from the load flow results and each method used as teachers respectively. The proposed ANN based method provides promising results in terms of accuracy and computation time. Artificial intelligence has been proven to be able to solve complex processes in deregulated power system such as loss allocation. So, it can be expected that the developed methodology will further contribute in improving the computation time of transmission usage allocation for deregulated system.

2. Importance of deregulation

Deregulated power systems unbundles the generation, transmission, distribution and retail activities, which are traditionally performed by vertically integrated utilities. Consequently different pricing policies will exist between different companies. With the separate pricing of generation, transmission and distribution, it is necessary to find the capacity usage of different transaction happening at the same time so that a fair use-of-transmission-system charge can be given to individual customer separately. Then the transparency in the operation of deregulated power systems can be achieved. In addition, the capacity usage is another application for transmission congestion management. For that reason the power produced by each generator and consumed by each load through the network should be trace in order to have acceptable solution in a fair deregulated power system. In Malaysian scenario the future electricity sector will be highly motivated to be liberalized, i.e. deregulated. Thus the proposed methodology is expected to contribute significantly to the development of the local deregulated power system. Promising test results were obtained from the extensive case studies conducted for several systems. These results shall bring about some differences from those based on other methods as different view-points and approaches may end up with different results. This chapter is offering the solution by an alternative method with better computational time and acceptable accuracy. These findings bring a new perspective on the

subject of how to improve the conventional real power allocation methods. A technically sound approach, to determine the real power output of individual generators, is proposed. This method is based on current operating point computed by the usual load flow code and basic equations governing the load flow in the network. The proposed MNE method has also been extended to reactive power allocation. The simulation results have also shown that of reactive power supply and reception in a power system is in conformity with a given operating point. The study results and analysis suggest that, the proposed MNE Method overcome problems arising in the conventional reactive allocation algorithms. From these two methods, the calculations results might bring about some differences because of the deviation in the concept applied by the proposed method. For example the proposed methods use each load current as a function of individual generators' current and voltage. This is different from the Chu's Method (Chu & Liao, 2004), where each load voltage is represented as a function of individual generators' voltage only. The proposed MNE Method for reactive power allocation is enhanced by utilizing ANN. When the performances of the developed ANN are investigated, it can be concluded that the developed ANN is more reliable and computationally faster than that of the MNE Method. Furthermore, the developed algorithms and tools for the proposed techniques have been used to investigate the actual 25 bus system of South Malaysia. The proposed methods have so far been focused on the viewpoint of suppliers. It is also very useful to develop and test the allocation procedures from the perspective of consumers. Both MNE Method and Chu's Method are equally suitable for modification in this respect. Additionally, this technique requires handling of future expansions into an ANN structure to make it a universal structure. Moreover adaptation of appropriate ANN architecture for the large real life test system is expected to deliver a considerable efficiency in computation time, especially during training processes. It may be a future work to analyze the performance of the algorithm for every change in the network topology.

3. Modified nodal equations method

The derivation, to decompose the load real powers into components contributed by specific generators starts with basic equations of load flow. Applying Kirchhoff's law to each node of the power network leads to the equations, which can be written in a matrix form as in equation (1) (Reta & Vargas, 2001):

$$I = YV \quad (1)$$

where:

V: is a vector of all node voltages in the system

I: is a vector of all node currents in the system

Y: is the Y-bus admittance matrix

The nodal admittance matrix of the typical power system is large and sparse, therefore it can be partitioned in a systematic way. Considering a system in which there are G generator nodes that participate in selling power and remaining $L = n - G$ nodes as loads, then it is possible to re-write equation (1) into its matrix form as shown in equation (2):

$$\begin{bmatrix} I_G \\ I_L \end{bmatrix} = \begin{bmatrix} Y_{GG} & Y_{GL} \\ Y_{LG} & Y_{LL} \end{bmatrix} \begin{bmatrix} V_G \\ V_L \end{bmatrix} \quad (2)$$

Solving for I_G and I_L using equation (2), the relationship can be obtained as shown in equations (3) and (4).

$$I_G = Y_{GG}V_G + Y_{GL}V_L \quad (3)$$

$$I_L = Y_{LG}V_G + Y_{LL}V_L \quad (4)$$

From equation (3), V_G can be solved as depicted in equation (5):

$$V_G = Y_{GG}^{-1}(I_G - Y_{GL}V_L) \quad (5)$$

Now, on substituting equation (5) in equation (4) and rearranging it, the load currents can be presented as a function of generators' current and load voltages as shown in equation (6):

$$I_L = Y_{LG}Y_{GG}^{-1}I_G + (Y_{LL} - Y_{LG}Y_{GG}^{-1}Y_{GL}) V_L \quad (6)$$

Then, the total real and reactive power S_L of all loads can be expressed as shown in equation (7):

$$S_L = V_L I_L^* \quad (7)$$

where (*) stands for conjugate,

Substituting equation (6) into equation (7) and solving for S_L the relationship as shown in equation (8) can be found;

$$\begin{aligned} S_L &= V_L (Y_{LG}Y_{GG}^{-1})^* I_G^* + V_L \left((Y_{LL} - Y_{LG}Y_{GG}^{-1}Y_{GL}) V_L \right)^* \\ &= \text{Re} \left\{ V_L \sum_{i=1}^{nG} \Delta I_L^* I_{Gi} + V_L \left((Y_{LL} - Y_{LG}Y_{GG}^{-1}Y_{GL}) V_L \right)^* \right\} \end{aligned} \quad (8)$$

where

$$(Y_{LG}Y_{GG}^{-1})^* I_G^* = \sum_{i=1}^{nG} \Delta I_L^* I_{Gi}$$

nG : number of generators

Now, in order to decompose the load voltage dependent term further in equation (8), into components of generator dependent terms, the equation (10) derivations are used. A possible way to deduce load node voltages as a function of generator bus voltages is to apply superposition theorem. However, it requires replacing all load bus current injections into equivalent admittances in the circuit. Using a readily available load flow results, the equivalent shunt admittance Y_{Lj} of load node j can be calculated using the equation (9):

$$Y_{Lj} = \frac{1}{V_{Lj}} \left(\frac{S_{Lj}}{V_{Lj}} \right)^* \quad (9)$$

S_{Lj} is the load complex power on node j and V_{Lj} is the bus load voltage on node j . After adding these equivalences to the diagonal entries of Y-bus matrix, equation (1) can be rewritten as in equation (10):

$$V = Y^{-1}I_G \quad (10)$$

where Y' is the modified Y .

Next, adopting equation (10) and taking into account each generator one by one, the load bus voltages contributed by all generators can be expressed as in equation (11):

$$V_L = \sum_{i=1}^{nG} \Delta V_L^{*I_{Gi}} \quad (11)$$

It is now, simple mathematical manipulation to obtain required relationship as a function of generators dependent terms. By substituting equation (11) into equation (8), the decomposed load real and reactive powers can be expressed as depicted in equation (12):

$$S_L = V_L \sum_{i=1}^{nG} \Delta I_L^{*I_{Gi}} + \sum_{i=1}^{nG} \Delta V_L^{*I_{Gi}} \left((Y_{LL} - Y_{LG} Y_{GG}^{-1} Y_{GL}) V_L \right)^* \quad (12)$$

This equation shows that the real and reactive power of each load bus consists of two terms by individual generators. The first term relates directly to the generator's currents and the second term corresponds to their contribution to load voltages. With further simplification of equation (12), the real and reactive power contribution that load j acquires from generator i is as shown in equation (13):

$$S_{Lj} = \sum_{i=1}^{nG} S_{Lji}^{\Delta I_L} + \sum_{i=1}^{nG} S_{Lji}^{\Delta V_L} \quad (13)$$

where:

$S_{Lji}^{\Delta I_L}$: current dependent term of generator i to S_{Lj}

$S_{Lji}^{\Delta V_L}$: voltage dependent term of generator i to S_{Lj}

All procedures of the computation mentioned above can be demonstrated as a flowchart illustrated in Figure 1. Vector S_{Lj} is used as a target in the training process of the proposed ANN.

3. Test conducted on the practical 25-bus equivalent power system of south Malaysia region

3.1 Application of ANN to real and reactive power allocation method

This section presents test conducted on the practical 25-bus equivalent power system of south Malaysia region. An ANN can be defined as a data processing system consisting of a large number of simple, highly interconnected processing elements (artificial neurons) in an architecture inspired by the structure of the cerebral cortex of the brain (Tsoukalas & Uhrig, 1997). The processing elements consist of two parts. The first part simply sums the weighted inputs; the second part is effectively a nonlinear filter, usually called the activation function, through which the combined signal flow. These processing elements are usually organized into a sequence of layers or slabs with full or random connections between the layers. Neural network perform two major functions which are training (learning) and testing (recall). Testing occurs when a neural network globally processes the stimulus presented at its input buffer and creates a response at the output buffer. Testing is an integral part of the training process since a desired response to the network must be compared to the actual output to create an error function.

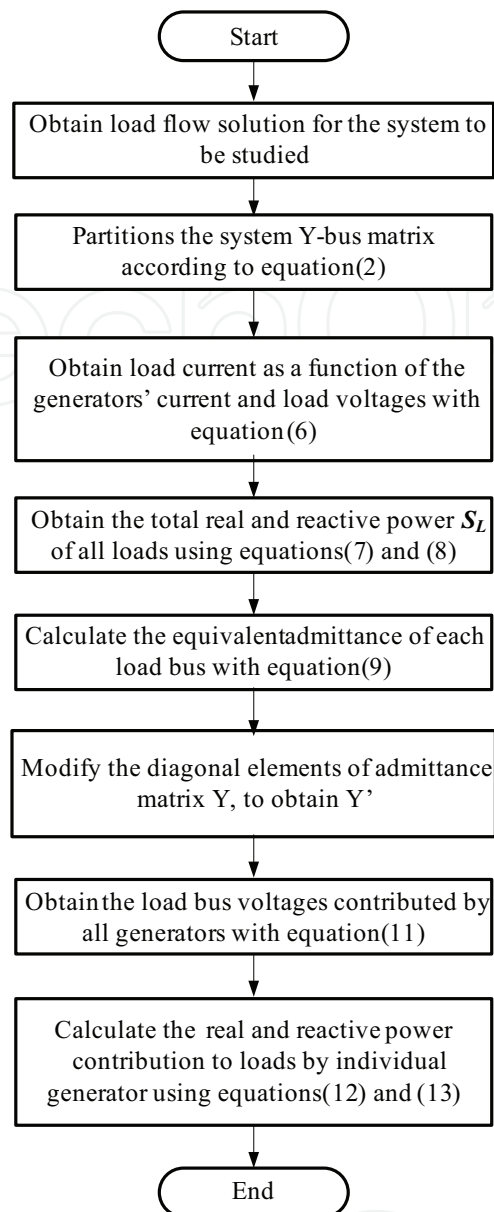

Fig. 1. Flow chart of the proposed real and reactive power allocation method

3.1.1 Structure of the proposed neural network in real and reactive power allocation method

In this work, 3 fully connected feedforward neural networks under MATLAB platform are utilized to obtain both real as well as reactive power transfer allocation results for the practical 25-bus equivalent power system of south Malaysia region as shown in Figure 2. This system consists of 12 generators located at buses 14 to 25 respectively. They deliver power to 5 loads, through 37 lines located at buses 1, 2, 4, 5, and 6 respectively. All discussions on designing of each of these ANN below are for this 25-bus equivalent system. Each network corresponds to four numbers of generators in the test system and each consists of two hidden layers and a single output layer. This means that in the first network is associated with four numbers of generator located at buses 14 to 17. This realization is adopted for simplicity and to reduce the training time of the neural networks.

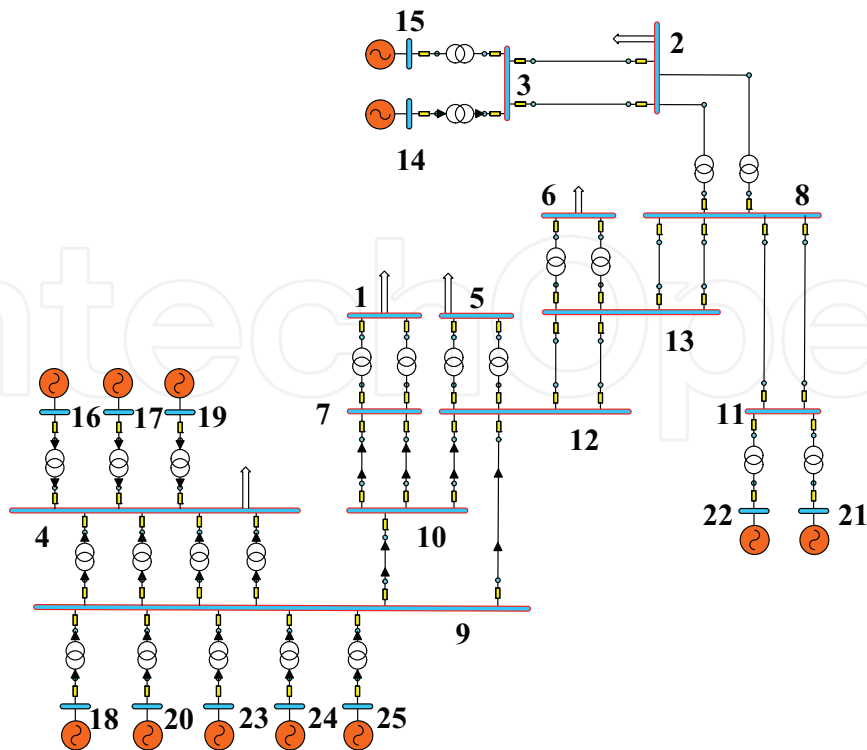

Fig. 2. Single line diagram for the 25-bus equivalent system of south Malaysia

The input samples for training is assembled using the daily load curve and performing load flow analysis for every hour of load demand. Again the load profile on hourly basis (Cheng, 1998) is utilized to produce 24 hours loads here also. Similarly the target vector for the training is obtained from the proposed method using MNE. Input data (D) for developed ANN contains independent variables such as real loads (P_1, P_2, P_4 to P_6) or reactive loads (Q_1, Q_2, Q_4 to Q_6) for real and reactive power transfer allocation respectively, bus voltage magnitude (V_1 to V_{13}) for both real as well as reactive power, real power (P_{line1} to P_{line37}) or reactive power (Q_{line1} to Q_{line37}) for line flows of real and reactive power transfer allocation respectively, and the target/output parameter (T) which is real or reactive power transfer between generators and loads placed at buses 1, 2, 4 to 6. This is considered as 20 outputs for both real as well as reactive power transfer allocation. Hence the networks have twenty output neurons. For the neural network 1, the first five neurons represent the contribution from generator 14 to the loads and the remaining outputs neurons correspond to the other three generators located at buses 15 to 17 respectively. Tables 1 and 2 summarize the description of inputs and outputs of the training data for each ANN for real and reactive power allocation respectively.

Input and Output (layer)	Neurons	Description (in p.u)
I_1 to I_5	5	Real loads
I_6 to I_{18}	13	Bus voltage magnitude
I_{19} to I_{55}	37	Real power for line flows
O_1 to O_{20}	20	Real power transfer between generators and loads

Table 1. Description of inputs and outputs of the training data for each ANN for real power

Input and Output (layer)	Neurons	Description (in p.u)
I ₁ to I ₅	5	Reactive loads
I ₆ to I ₁₈	13	Bus voltage magnitude
I ₁₉ to I ₅₅	37	Reactive power for line flows
O ₁ to O ₂₀	20	Reactive power transfer between generators and loads

Table 2. Description of inputs and outputs of the training data for each ANN for reactive power

3.1.2 Training

Neural networks are sensitive to the number of neurons in their hidden layer. Too few neurons in the hidden layer prevent it from correctly mapping inputs to outputs, while too many may impede generalization and increasing training time. Therefore number of hidden neurons is selected through experimentation to find the optimum number of neurons for a predefined minimum of mean square error in each training process. To take into account the nonlinear characteristic of input (D) and noting that the target values are either positive or negative, the suitable transfer function to be used in the hidden layer is a tan-sigmoid function. Non linear activation functions allow the network to learn nonlinear relationships between input and output vectors. Levenberg-Marquardt algorithm has been used for training the network. After the input and target for training data is created, next step is to divide the data (D and T) up into training, validation and test subsets. In this case 100 samples (60%) of data are used for the training and 34 samples (20%) of each data for validation and testing. Table 3 shows the numbers of samples for training, validation and test data for real and reactive power allocation respectively.

Data Types	Number of Samples (Hour)
Training	100
Validation	34
Testing	34

Table 3. The number of samples for training, validation and test set

The error on the training set is driven to a very small value i.e. 3.5×10^{-8} . If the calculated output error becomes much larger than acceptable, when a new data is presented to the trained network, then it can be said that the network has memorized the training samples, but it has not learned to generalize to new situations. Validation sets is used to avoid this overfitting problem. The test set provides an independent measure of how well the network can perform on data not used to train it. In real power allocation scheme, the performance of the training for the ANN with two hidden layers having different number of neurons i.e. 15 and 10 respectively is as shown in Figure 3. From Figure 3, it can also be seen that the training goal is achieved in 12 epochs with a mean square error of 8.897×10^{-9} . For reactive power allocation scheme, the performance of the training for the ANN is also made with two hidden layers having different number of neurons i.e. 10 and 15 respectively as shown in Figure 4.

In this Figure 4 the training goal is achieved in 13 epochs with a mean square error of 9.50128×10^{-9} . Note that the mean square error is not much different for both real as well as reactive power transfer allocation. This indicates that the developed ANN can allocate both real as well as reactive power transfer between generators and loads with almost similar accuracy.

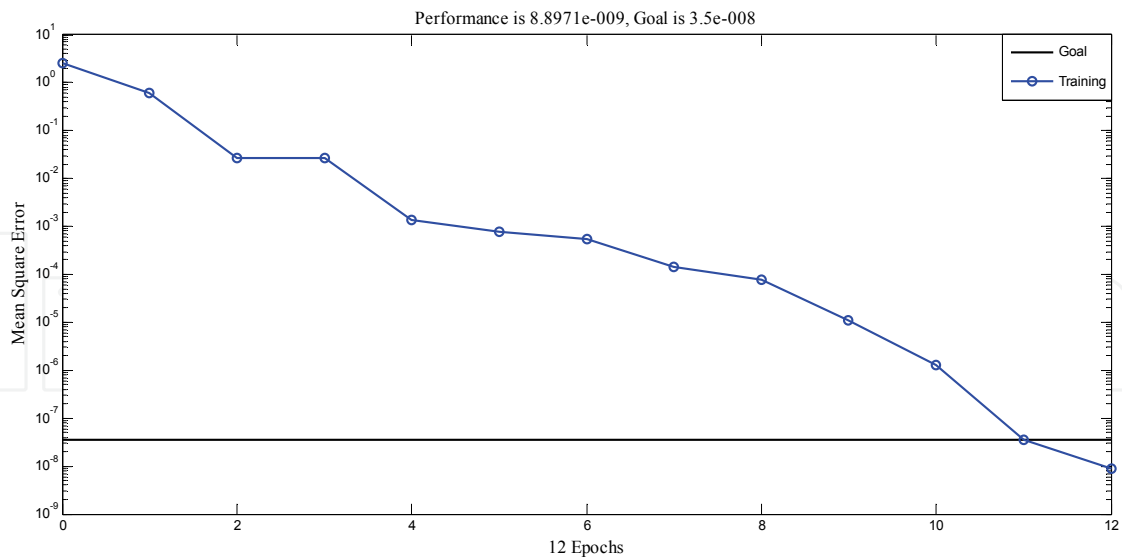

Fig. 3. Training curve with two hidden layers having different number of neurons i.e. 15 and 10 respectively for real power allocations

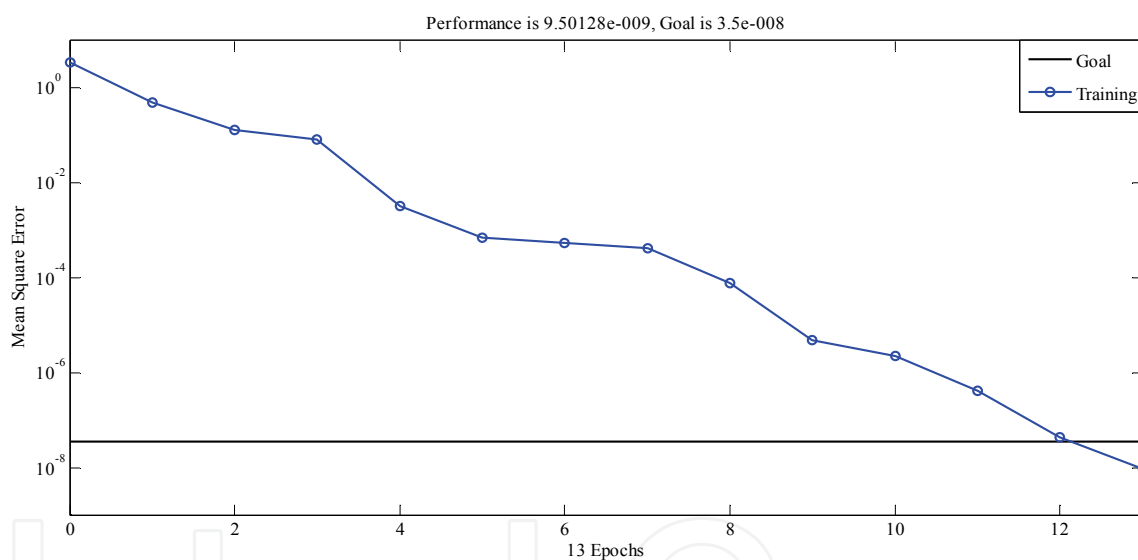

Fig. 4. Training curve with two hidden layers having different number of neurons i.e. 10 and 15 respectively for reactive power allocations

The result is reasonable, since the test set error and the validation set error have similar characteristics with the training set, and it doesn't appear that any significant overfitting has occurred. The same network setting parameters is used for training the other 2 networks.

3.1.3 Pre-testing and simulation

After the networks have been trained, next step is to simulate the network. The entire sample data is used in pre testing. After simulation, the obtained result from the trained network is evaluated with a linear regression analysis. In real power allocation scheme, the regression analysis for the trained network that referred to contribution of generator at bus 15 to load at bus 1 is shown in Figure 5.

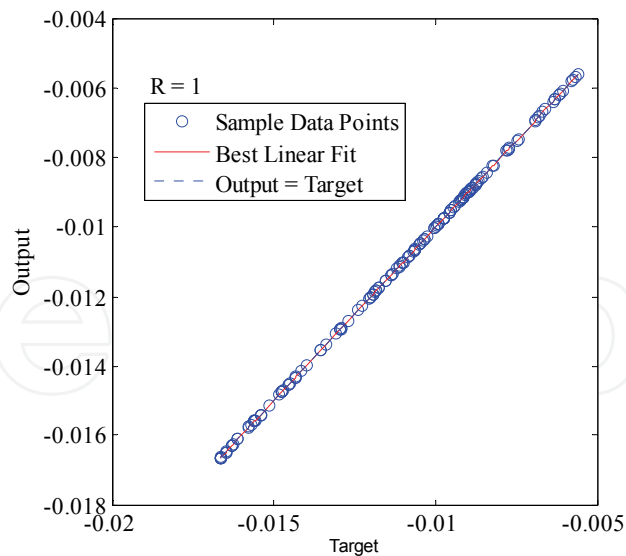

Fig. 5. Regression analysis between the network output and the corresponding target for real power allocation

The correlation coefficient, (R) in this case is equal to one which indicates perfect correlation between MNE Method and output of the neural network. The best linear fit is indicated by a solid line whereas the perfect fit is indicated by the dashed line. Subsequently, similar results is obtained on regression analysis for reactive power allocation method for the trained network that referred to contribution of generator at bus 14 to load at bus 2 as shown in Figure 6.

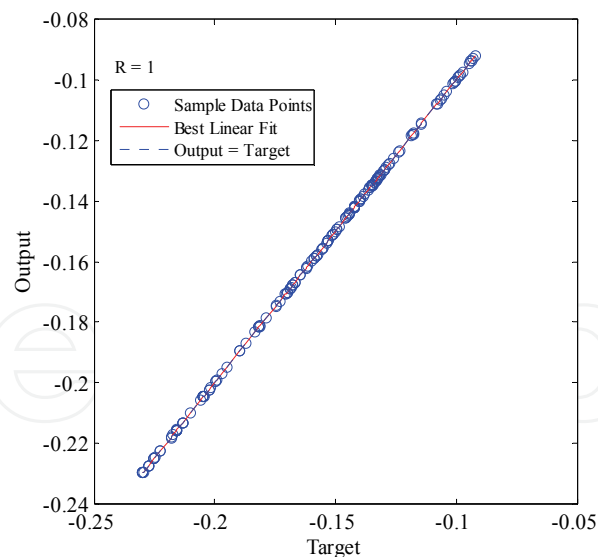

Fig. 6. Regression analysis between the network output and the corresponding target for reactive power allocation

Finally, both real as well as reactive power contribution to loads is determined and compared with the MNE Method's output. Daily load curves for every load bus are shown in Figures 7 to 8 and the target patterns for generator located at buses 14 and 22 are given in Figures 9 to 12.

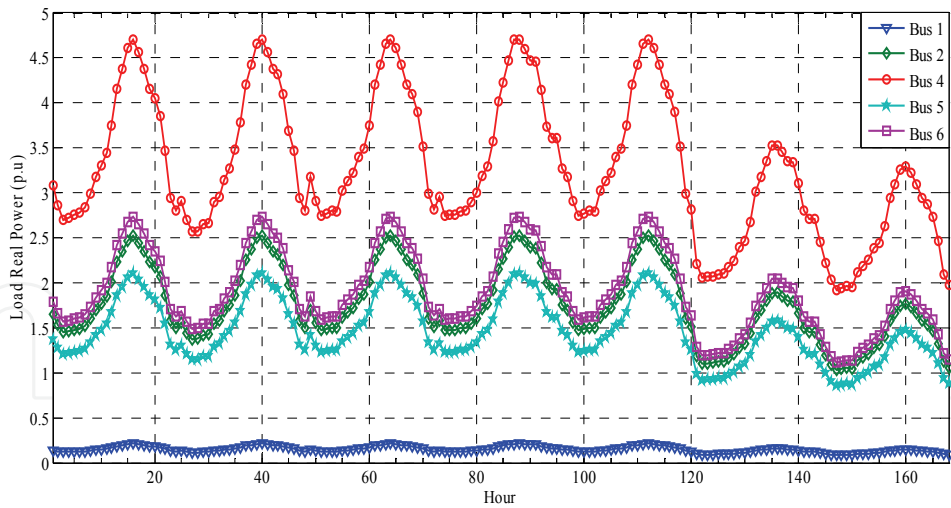

Fig. 7. Real power allocation method daily load curves for different buses

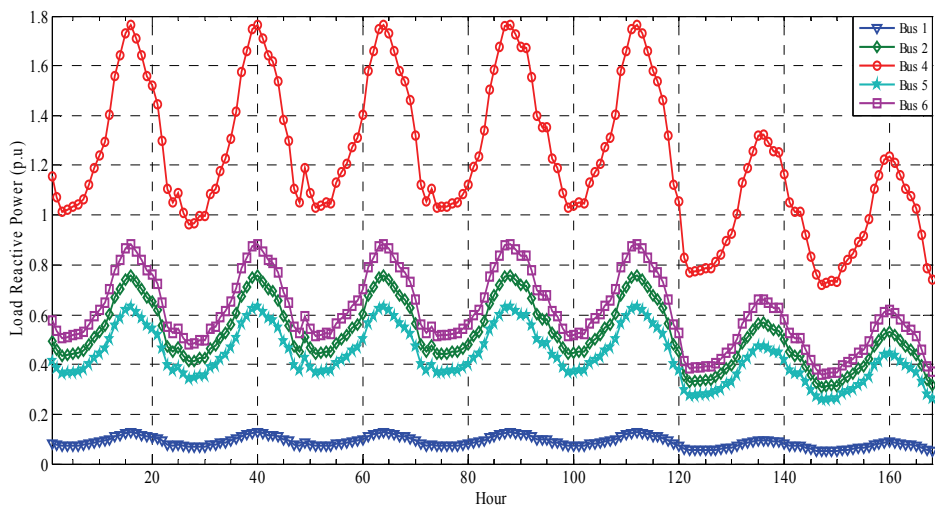

Fig. 8. Reactive power allocation method daily load curves for different buses

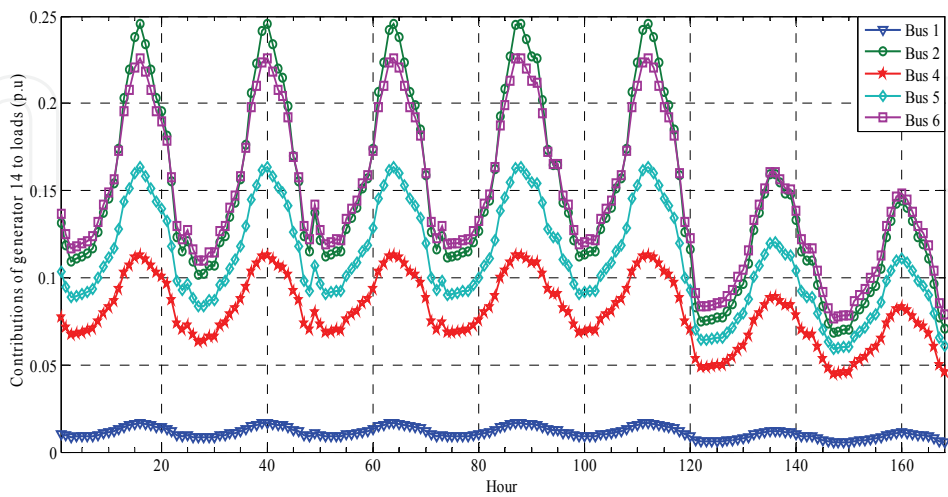

Fig. 9. Selected target patterns of generator at bus 14 of real power allocation scheme within 168 hours

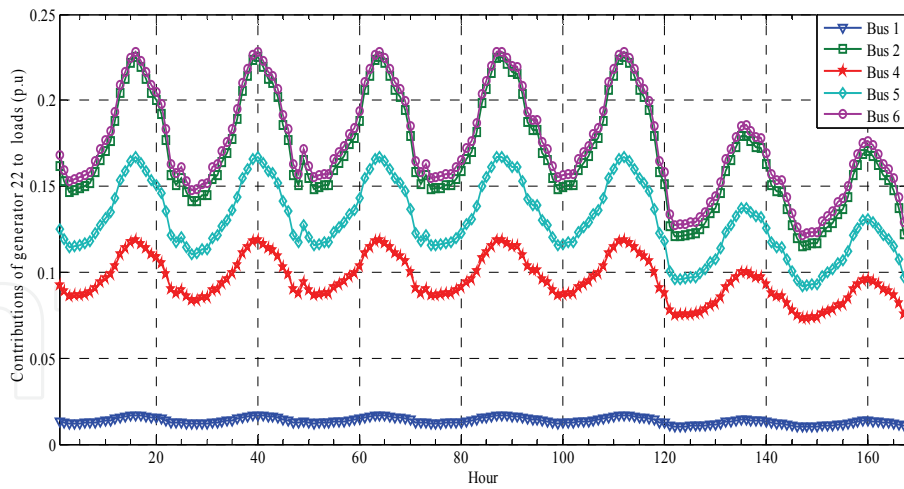

Fig. 10. Selected target patterns of generator at bus 22 of real power allocation scheme within 168 hours

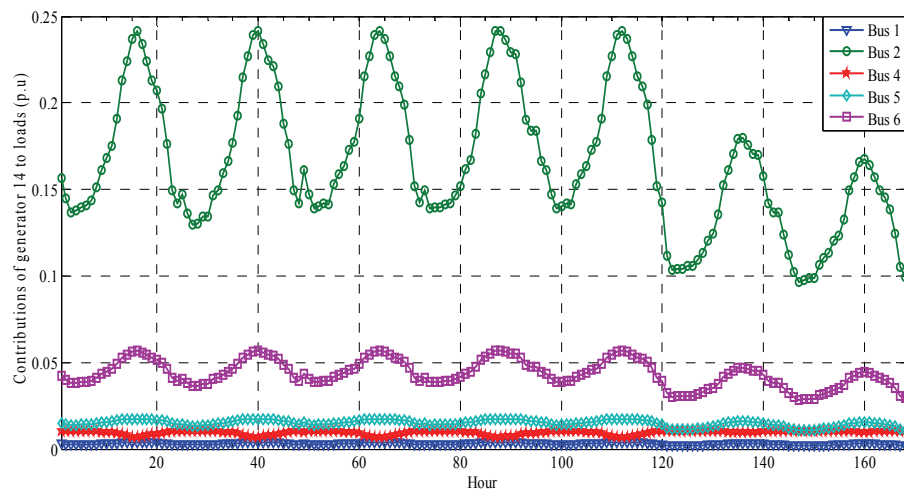

Fig. 11. Selected target patterns of generator at bus 14 of reactive power allocation scheme within 168 hours

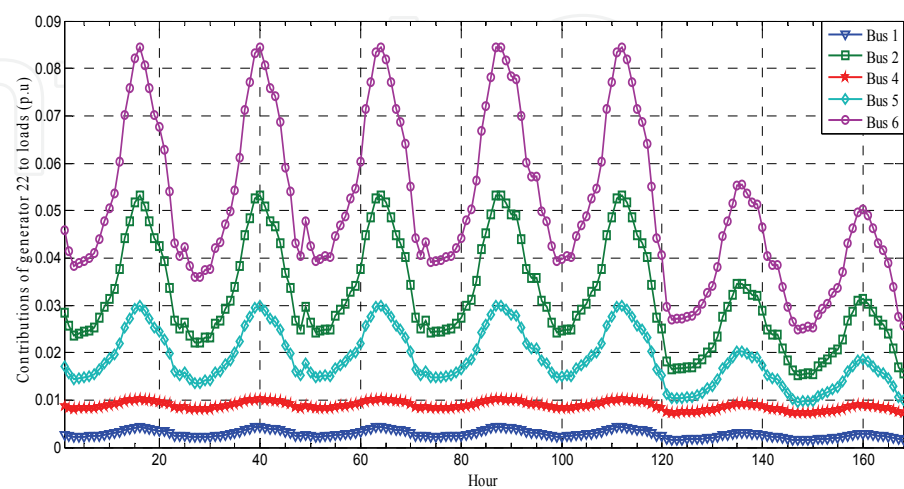

Fig. 12. Selected target patterns of generator at bus 22 of reactive power allocation scheme within 168 hours

4. Real power allocation results for 25-bus test system

At different loads, comparison of results of (Bialek, 1996) Method with the proposed method is as shown in Table 4. It is observed that, the results of proposed method is very much comparable with (Bialek, 1996) Method. Due to the different approach the difference of allocation factor lies between the results of proposed method and (Bialek, 1996) Method occurred at each load buses 1, 2, and 4 to 6. This difference does not exist i.e. zero contribution in the (Bialek, 1996). Method for about half count buses while the proposed method distribute allocation factor to all load buses. The other difference of the proposed method is due to the use of basic system nodal equations which minimize the simplifying assumptions such as the proportional sharing and lossless network as considered in Bialek's Method. From Table 4, it can also be observed that the sum of the real power contributed by each generator is in conformity with the solved load flow. In this system, (Bialek, 1996) Method and the proposed method can compute the required relationship with similar computation time i.e. within 46 msec. Hence, it is proven that the proposed methodology provides reasonable and acceptable results to real power transfer allocation as compared to (Bialek, 1996) Method.

Supplied by	Load bus no.									
	Modified Nodal Equations Method					Bialek's Method				
(MW)	1	2	4	5	6	1	2	4	5	6
Gen-14	1.150	15.041	8.519	11.475	15.318	0	71.274	0	0	0
Gen-15	1.150	15.041	8.519	11.475	15.318	0	71.274	0	0	0
Gen-16	1.489	16.741	96.602	14.772	18.816	0	0	85.144	0	0
Gen-17	1.456	16.257	93.268	14.388	18.307	0	0	82.090	0	0
Gen-18	0.93393	10.786	7.210	9.402	12.027	2.181	0	16.593	21.805	13.444
Gen-19	1.064	11.538	64.478	10.35	13.108	0	0	56.392	0	0
Gen-20	0.97752	11.451	7.619	9.919	12.717	2.353	0	17.903	23.527	14.505
Gen-21	1.343	17.026	9.602	13.087	17.626	0	19.446	0	0	51.670
Gen-22	1.376	17.389	9.759	13.337	17.997	0	19.446	0	0	51.670
Gen-23	1.376	16.756	11.011	14.275	18.408	3.586	0	27.292	35.863	22.111
Gen-24	1.248	14.774	9.796	12.739	16.358	3.070	0	23.362	30.699	18.927
Gen-25	1.554	18.643	12.308	15.982	20.564	3.931	0	29.912	39.306	24.234
Total Load	15.120	181.443	338.691	151.202	196.564	15.121	181.440	338.688	151.200	196.561
Actual Load	15.12	181.44	338.69	151.2	196.56	15.12	181.44	338.69	151.2	196.56

Table 4. Comparison of the real power distribution by each generator to load at buses 1, 2, 4 to 6 for the practical 25-bus equivalent power system

The proposed MNE Method has been simulated to reveal the accuracy of the developed ANN. The case scenario is that the real and reactive load is decreasing in 10% from the nominal trained pattern. Furthermore, it is also assumed that all generation is divided proportionally according to the load demands, to ensure that all real power generation of generator at buses 14 to 25 varies in respond to the daily load pattern of the loads at least by a small amount rather than to give the unbalance load only to the slack generator. Figure 13 shows the real power transfer allocation results due to generator located at bus 14 by the ANN output along with the result obtained through to proposed method for loads at buses 1, 2, and 4 to 6 within 168 hours.

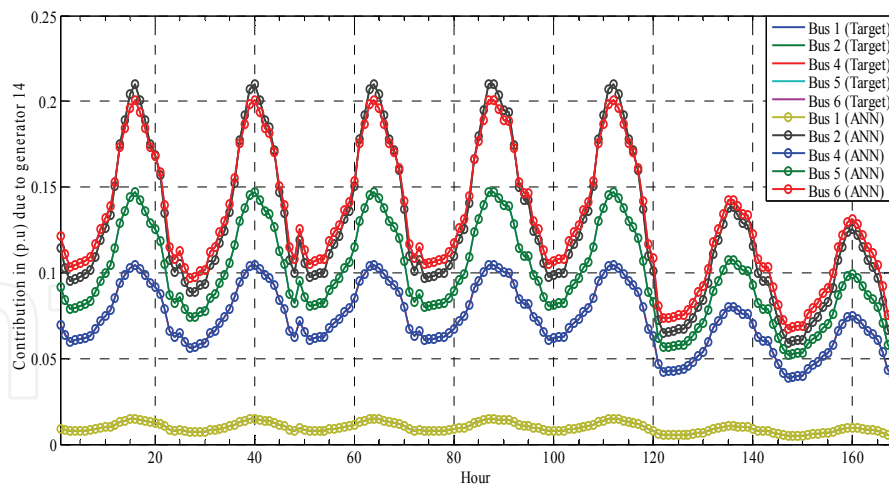

Fig. 13. Distribution of real power from generator at bus 14 to loads within 168 hours

Results obtained from the ANN output are indicated with lines having circles and the solid lines represent the output of the MNE Method. From Figure 13, it can be observed that the developed ANN can allocate real power transfer between generators and load with very good accuracy, almost 100 %. In this simulation, ANN computes within 45 msec whereas the MNE Method takes 1314 msec for the same real power transfer allocation. Consequently, it can be concluded that the ANN is more efficient in terms of computation time. Moreover, the final allocation of real power to loads on hours twelve out of 168 hours using developed ANN is presented in Table 5 along with the result obtained through MNE Method. Note that the result obtained by the ANN output is comparable with the result of MNE Method. The difference of real power between generators in both methods is very small which is less than 0.0053 MW.

Supplied by (MW)	Load bus no.									
	ANN Output					Modified Nodal Equations Method				
	1	2	4	5	6	1	2	4	5	6
Gen-14	1.150	15.042	8.519	11.476	15.319	1.150	15.041	8.519	11.475	15.318
Gen-15	1.150	15.043	8.519	11.477	15.32	1.150	15.041	8.519	11.475	15.318
Gen-16	1.489	16.744	96.603	14.773	18.816	1.489	16.741	96.602	14.772	18.816
Gen-17	1.456	16.258	93.273	14.388	18.308	1.456	16.257	93.268	14.388	18.307
Gen-18	0.93393	10.786	7.210	9.402	12.027	0.93393	10.786	7.210	9.402	12.027
Gen-19	1.064	11.538	64.477	10.35	13.108	1.064	11.538	64.478	10.35	13.108
Gen-20	0.97752	11.451	7.619	9.919	12.717	0.97752	11.451	7.619	9.919	12.717
Gen-21	1.343	17.026	9.602	13.087	17.626	1.343	17.026	9.602	13.087	17.626
Gen-22	1.375	17.389	9.759	13.336	17.996	1.376	17.389	9.759	13.337	17.997
Gen-23	1.376	16.755	11.01	14.275	18.407	1.376	16.756	11.011	14.275	18.408
Gen-24	1.248	14.773	9.795	12.739	16.357	1.248	14.774	9.796	12.739	16.358
Gen-25	1.553	18.642	12.307	15.981	20.563	1.554	18.643	12.308	15.982	20.564
Total Load	15.120	181.446	338.697	151.202	196.564	15.120	181.443	338.691	151.202	196.564
Actual Load	15.12	181.44	338.69	151.2	196.56	15.12	181.44	338.69	151.2	196.56

Table 5. Analysis of real power allocation for the practical 25-bus equivalent power system of south Malaysia

5. Reactive power allocation results for 25-bus test system

Table 6 shows a comparison of reactive power distribution of generators at buses 14 to 25 obtained through the Chu's Method (Chu & Liao,2004) and proposed MNE Method. By comparing the values depicted in Table 6, it is obvious that the reactive power allocation made by the proposed method is slightly difference from that of Chu's Method. The difference in the result between both methods is only noticeable for load at bus 4 while the results of others load buses are almost similar. This may due to the concept applied by the proposed method which represents each load current as a function of individual generators' current and voltage. On the other hand the Chu's Method represents each load voltage as a function of individual generators' voltage.

Supplied by (MVar)	Load bus no.									
	Modified Nodal Equations Method					Chu's Method				
	1	2	4	5	6	1	2	4	5	6
Gen-14	0.31492	17.18	0.96389	1.5687	4.5436	0.31492	17.18	2.5279	1.5687	4.5436
Gen-15	0.31492	17.18	0.96389	1.5687	4.5436	0.31492	17.18	2.5279	1.5687	4.5436
Gen-16	0.74182	1.2167	36.688	3.4787	4.0287	0.74182	1.2167	23.467	3.4787	4.0287
Gen-17	0.73775	1.2058	36.835	3.4491	3.9978	0.73775	1.2058	23.325	3.4491	3.9978
Gen-18	0.97819	1.6864	3.2764	4.7926	5.484	0.97819	1.6864	8.6761	4.7926	5.484
Gen-19	0.57913	0.93221	30.051	2.6715	3.1082	0.57913	0.93221	18.266	2.6715	3.1082
Gen-20	0.99247	1.7194	3.3289	4.8834	5.5814	0.99247	1.7194	8.8266	4.8834	5.5814
Gen-21	0.28846	3.2488	0.89633	1.9222	5.2149	0.28846	3.2488	2.4623	1.9222	5.2149
Gen-22	0.28846	3.2488	0.89633	1.9222	5.2149	0.28846	3.2488	2.4623	1.9222	5.2149
Gen-23	1.2757	2.2432	4.2971	6.3601	7.2436	1.2757	2.2432	11.44	6.3601	7.2436
Gen-24	1.248	2.1686	4.1895	6.1571	7.0321	1.248	2.1686	11.118	6.1571	7.0321
Gen-25	1.2941	2.2928	4.3687	6.4951	7.3842	1.2941	2.2928	11.655	6.4951	7.3842
Total Load	9.05392	54.3227	126.755	45.2694	63.377	9.05392	54.3227	126.7541	45.2694	63.377
Actual Load	9.0539	54.323	126.75	45.269	63.377	9.0539	54.323	126.75	45.269	63.377

Table 6. Reactive power distribution of generators to loads for the 25-bus equivalent system

A number of simulations have been carried out to demonstrate the accuracy of the developed ANN with the same 25-bus equivalent system of south Malaysia. The scenario is a decrement by 10% of the real and reactive load demand from the nominal trained pattern. Besides it also assumed that all generators also decrease their production proportionally according to this variation in the load demands. Figure 14 shows the reactive power transfer allocation result for generator located at bus 14 calculated by the ANN along with the result obtained through MNE Method for loads at buses 1, 2, and 4 to 6 within 168 hours.

The pattern used for results is same as of real power allocation. From Figure 14, it can be observed that the developed ANN can allocate reactive power transfer between generators and load with very good accuracy, almost 100%. In this simulation, ANN computes within 45 msec whereas the MNE Method took 908 msec for the calculation of same reactive power transfer allocation. Therefore it can be concluded that the ANN is more efficient in terms of computation time. From Table 7, it can be noted that the result obtained by the ANN output in this thesis is compared well with the result of MNE Method.

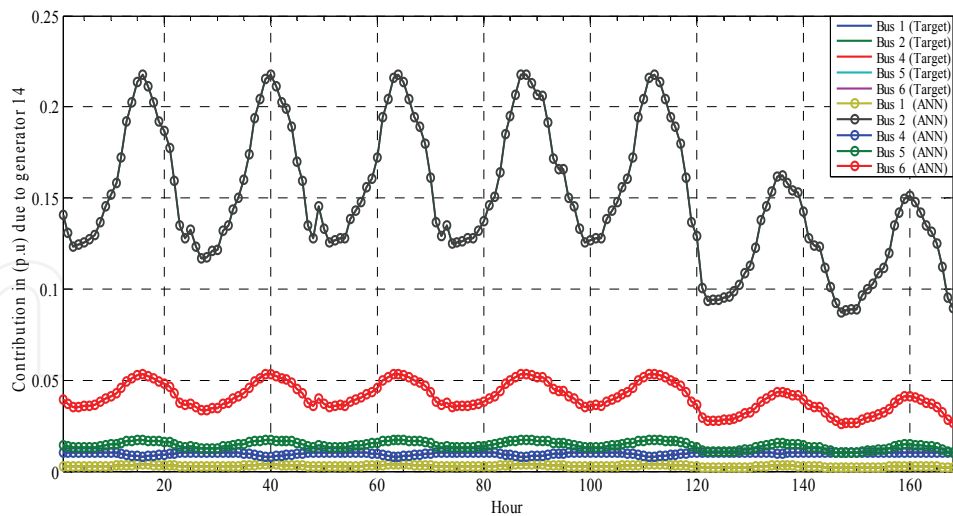

Fig. 14. Distribution of reactive power from generator at bus 14 to loads within 168 hours

Supplied by (MVar)	Load bus no.									
	ANN Output					Modified Nodal Equations Method				
	1	2	4	5	6	1	2	4	5	6
Gen-14	0.31492	17.18	0.96386	1.5686	4.5436	0.31492	17.18	0.96389	1.5687	4.5436
Gen-15	0.31492	17.18	0.96386	1.5687	4.5435	0.31492	17.18	0.96389	1.5687	4.5436
Gen-16	0.74181	1.2167	36.689	3.4786	4.0286	0.74182	1.2167	36.688	3.4787	4.0287
Gen-17	0.73775	1.2058	36.835	3.449	3.9978	0.73775	1.2058	36.835	3.4491	3.9978
Gen-18	0.97821	1.6865	3.2764	4.7927	5.4841	0.97819	1.6864	3.2764	4.7926	5.484
Gen-19	0.57914	0.9322	30.05	2.6715	3.1082	0.57913	0.93221	30.051	2.6715	3.1082
Gen-20	0.99249	1.7194	3.3288	4.8834	5.5815	0.99247	1.7194	3.3289	4.8834	5.5814
Gen-21	0.28846	3.2489	0.89634	1.9223	5.2152	0.28846	3.2488	0.89633	1.9222	5.2149
Gen-22	0.28845	3.2487	0.89632	1.9222	5.2147	0.28846	3.2488	0.89633	1.9222	5.2149
Gen-23	1.2756	2.2431	4.2971	6.3599	7.2433	1.2757	2.2432	4.2971	6.3601	7.2436
Gen-24	1.2479	2.1685	4.1894	6.1569	7.0319	1.248	2.1686	4.1895	6.1571	7.0321
Gen-25	1.2941	2.2928	4.3687	6.4949	7.3839	1.2941	2.2928	4.3687	6.4951	7.3842
Total Load	9.05375	54.3226	126.755	45.2687	63.3763	9.05392	54.32271	126.755	45.2694	63.377
Actual Load	9.0539	54.323	126.75	45.269	63.377	9.0539	54.323	126.75	45.269	63.377

Table 7. Analysis of reactive power allocation for the 25-bus equivalent system

The difference of reactive power between generators in both methods is very small, which are less than 10^{-3} MVar. The consumer located at bus 4 consumed the highest demand compared to other consumers in this hour. Consequently, the contribution of reactive power due to generators 16, 17 and 19 located at the same bus provides more reactive power to load at bus 4 by both methods as well. For this reason the acquired result illustrates that the contribution of individual generators are mostly confined in their neighborhood.

6. Test conducted on the IEEE 118 bus system

The proposed methods have also been tested on IEEE 118 bus system. This system consists of 186 lines, 33 physical reactive power sources and 54 real power generators.

6.1.1 Application of RBFN in real and reactive power allocation method

One of the main purposes of this work is to incorporate RBFN into real and reactive power allocation method between generators and load. The structure of the proposed RBFN for each allocation scheme is discussed in the following sub-sections.

6.1.2 Real power allocation method

In this case study, RBFN with one hidden layer and one output layer has been chosen. The proposed allocation method is elaborated by designing an appropriate RBFN for the IEEE 118 bus system as shown in Figure 15. This system consists of 54 generators located at selected buses which lies in between buses numbered as 1 to 118. They deliver power to 64 loads, through 186 branches located at selected buses which lies in between buses numbered as 1 to 118.

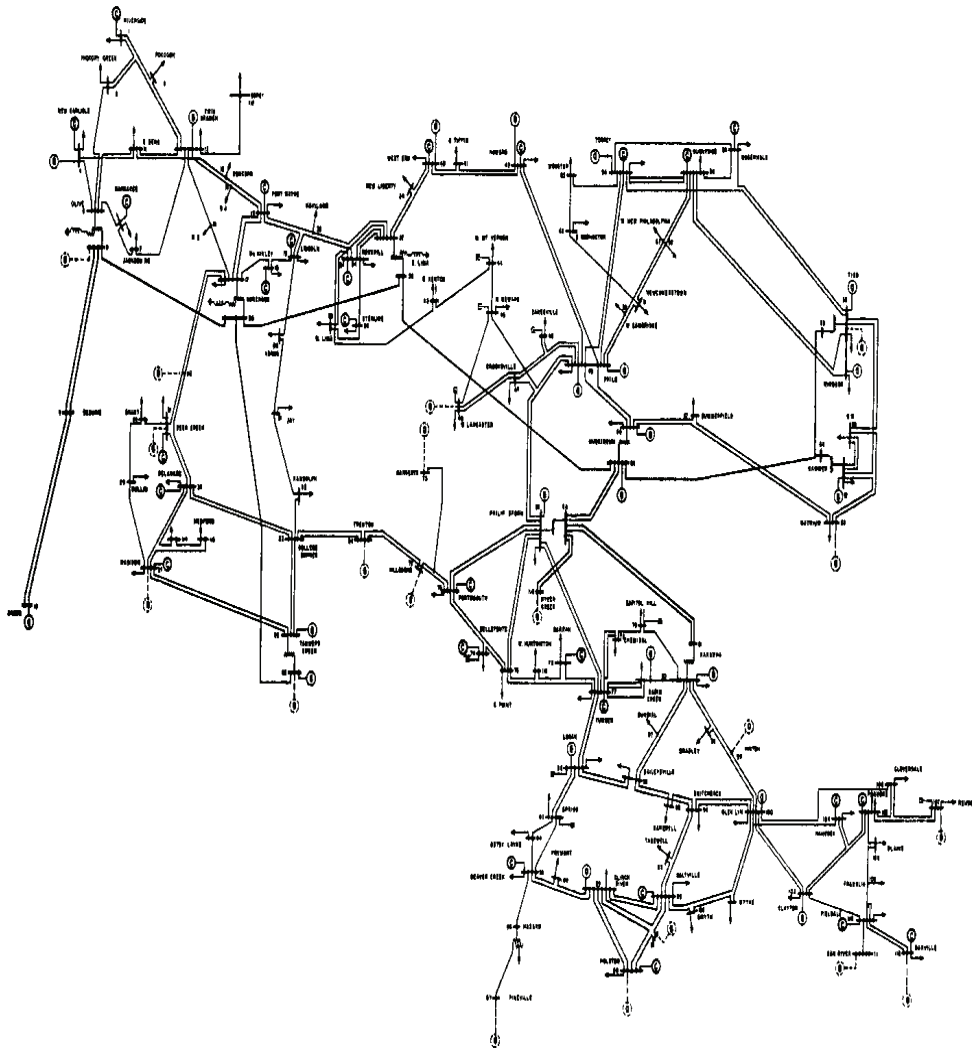

Fig. 15. Single line diagram for the IEEE 118 bus system

The input samples for training is assembled using the daily load curve and performing load flow analysis for every hour of load demand. Again the load profile on hourly basis (Cheng, 1998) is utilized to produce 24 hours loads here also. Similarly the target vector for the training is obtained from the proposed method using nodal equations. Input data (D) for

developed ANN contains independent variables such as real power generation located at selected buses which lies in between buses numbered as (P_{g1} , to P_{g118}), real loads located at selected buses which lies in between buses numbered as (P_2 to P_{118}), reactive loads located at selected buses which lies in (Q_2 to Q_{118}), average power for line flows (P_{line1} to $P_{line186}$) and the target/output parameter, (T) which is real power transfer between generators and loads placed at selected buses which lies in between buses numbered as 2 to 118. This is considered as 3456 outputs and therefore the networks have three thousand, four hundred and fifty six output neurons. Each generator allocates to the sixty four output neurons which correspond to the loads located at selected buses which lies in between buses numbered as 2 to 118. For example, the first sixty four neurons (1-64) represent the contribution from generator at bus 1 to the sixty four loads, the second sixty four neurons (65-128) represent the contribution from generator at bus 4 to the sixty four loads and so on for generators located at selected buses which lies in between buses numbered as 1 to 118. Table 8 summarizes the description of inputs and outputs of the training data for the RBFN.

Input and Output (layer)	Neurons	Description (in p.u)
I ₁ to I ₅₄	54	Real power generations
I ₅₅ to I ₁₁₈	64	Real loads
I ₁₁₉ to I ₁₈₂	64	Reactive loads
I ₁₈₃ to I ₃₆₈	186	Average power for line flows
O ₁ to O ₃₄₅₆	3456	Real power transfer between gen. and loads

Table 8. Description of inputs and outputs of the training data for the RBFN

6.1.3 Reactive power allocation scheme

In this case study, structure and description of input and output of each RBFN is similar to those of the real power allocation scheme. Table 9 shows the details of inputs and outputs of the training data for the RBFN.

Input and Output (layer)	Neurons	Description (in p.u)
I ₁ to I ₅₄	54	Real power generations
I ₅₅ to I ₁₁₈	64	Real loads
I ₁₁₉ to I ₁₈₂	64	Reactive loads
I ₁₈₃ to I ₃₆₈	186	Average power for line flows
O ₁ to O ₃₄₅₆	3456	Reactive power transfer between gen. and loads

Table 9. Description of inputs and outputs of the training data for the RBFN

6.1.4 Unsupervised learning to choose the centers of training samples

The well-known k -means clustering algorithm is used to find a set of centers for the training samples. In k -means clustering, the number of desired centers (k), must be decided in advance. One simple way of choosing the value of k is to set it equal to a fraction of total training data samples. The k -means algorithm is as follows (Abdullah, 2008):

Step 1: Assign the input data to random k sets.

Step 2: Compute the mean of each set.

Step 3: Reassign each point to a new set according to which is the nearest mean vector.

Step 4: Recomputed the mean of each set.

Step 5: Repeat steps 3 and 4 until there is no further change in the grouping of data points.

Step 6: The mean of the sets will be the RBFN center.

6.1.5 Training

After the input and target for training data is created, it can be made more efficient to scale (preprocess) the network inputs and targets so that they always fall within a specified range. In this case the minimum and maximum value of input and output vectors is used to scale them in the range of -1 and +1. Next step is to divide the input data and target data up into training. In this case 14 samples (60%) of data are used for the training as shown in Table 10.

Data Types	Samples (Hour)
Training	1,6,11,16,21,3,8,13,18,23,5,10,15,20

Table 10. The Numbers of Samples for Training

The training of the RBFN consists of two separate stages. First step is to find the centers parameter by using the k-means clustering algorithm. Initially, the number of trials with different number of k keeping the β constant and vice versa is set. In both real and reactive power allocation scheme, the k is taken as 14 samples equal to number of hours and the β as 10, resulting in reasonable accuracy of the output of the RBFN with the target. For this $k=14$ and $\beta=10$, the computed training time i.e. 187 msec taken by the RBFN is same for both of the real and reactive power allocation scheme. Total number of the second layer weights influencing the individual output is, 14. Therefore, the minimum number of data set required to train the network is 14. In the second training stage, the second layer weights in connections between the hidden layer and the output layer are determined using the least squares based on minimization of quadratic errors of RBFN network output values over the set of training input-output vector pairs. At that stage, the weights in connections between the input layer and the hidden layer and the parameters of the radial basis functions of the hidden layer are already set as determined in the first training stage and are not subject to any further changes. During this training, the RBFN network is presented with individual input vectors from the set of training samples and responds with certain output vectors. These output vectors are compared with the target output vectors also given in the training set, and the individual weights are updated in a way ensuring a decrease of the difference between the actual and target output vectors. The individual input-output training pairs are presented to the RBFN network repeatedly until the error decreases to an acceptable level.

6.1.6 Pre-testing and simulation

In first step using MATLAB, the network is to be trained. In the second step involves simulating the network. The entire sample data is used in pre testing. After simulation, the obtained result from the trained network is evaluated with a linear regression analysis. The regression analysis for the trained network that referred to contribution of generator at bus 1 to load at bus 2 is shown in Figure 16.

The correlation coefficient, (R) in this case is equal to one which indicates perfect correlation between MNE Method and output of the neural network. The best linear fit is indicated by a solid line whereas the perfect fit is indicated by the dashed line. Moreover, performing regression analysis of reactive power allocation scheme for the trained network, similar results is obtained which refers to contribution of generator at bus 1 to load at bus 16 as shown in Figure 17.

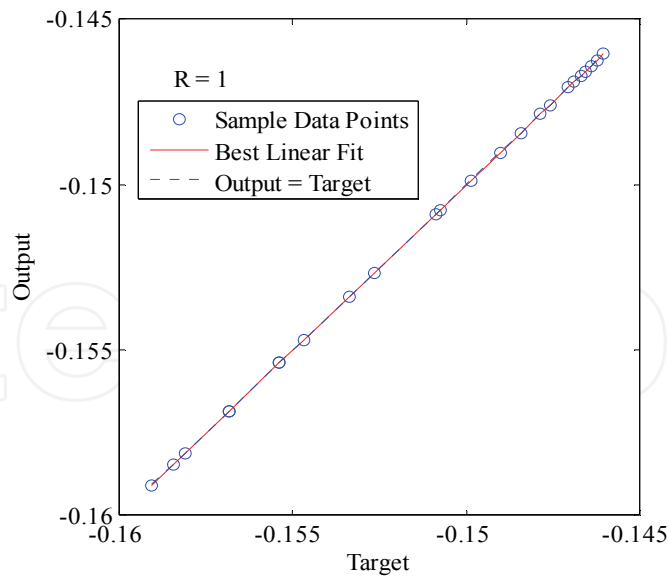

Fig. 16. Regression analysis between the network output and the corresponding target keeping $k = 14$ and $\beta = 10$ for real power allocation

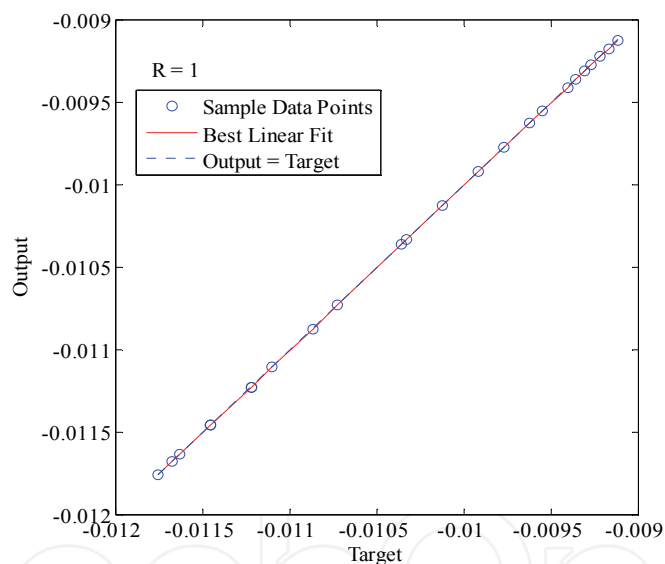

Fig. 17. Regression analysis between the network output and the corresponding target keeping $k = 14$ and $\beta = 10$ for reactive power allocation

6.1.7 Real power allocation results for IEEE 118 bus system

The case scenario is that increment by 10% of the real and reactive load demand from the nominal trained pattern. In addition it is also assumed that all generation is divided linearly according to the load demands. Figure 18 shows the real power transfer allocation result for generator located at bus 69 calculated by the RBFN along with the result obtained through to the MNE Method for loads at buses 41, 43, 44, 45, 47, 48, 53, 57, 58 and 79 within 24 hours. Results obtained from the RBFN are indicated with lines having circles, and the solid lines represent the output of the MNE Method. From Figure 18, it can be observed that the developed RBFN can allocate real power transfer between generators and load with very

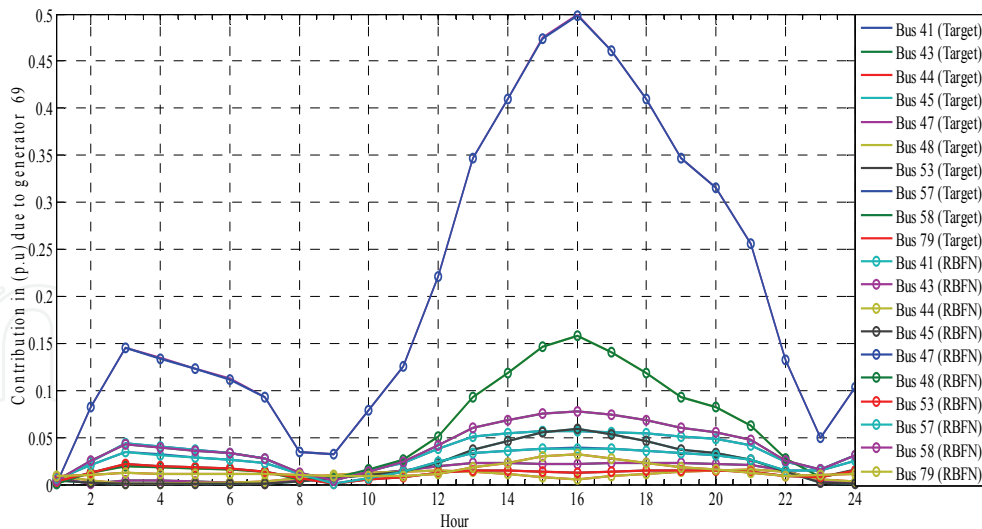

Fig. 18. Distribution of real power from generator at bus 69 to loads within 24 hours

good accuracy, almost 100%. In this simulation, RBFN computes within 15 ms, whereas the MNE Method took 3000 ms for the calculation of same real power transfer allocation. For that reason it can be concluded that the RBFN is more efficient in terms of computation time. Moreover, the final allocation of real power to loads using proposed RBFN on hours 12 out of 24 hours is presented in Table 11 along with the result obtained through MNE Method. It can be noted that the result obtained by the proposed RBFN compares well with the result of MNE Method. The difference of real power between generators in both methods is too small i.e. less than 7.687×10^{-4} MW. It is worth noting that the total contributions of each generator to loads are reasonable since it is less than its total production. For example, the total contribution of generator at bus 107 to all loads is 56.609 MW and this value does not exceed its generation i.e. 60MW.

Bus no.	Actual load (MW)	RBFN Output						Modified Nodal Equations Method					
		Gen-107 (MW)	Gen-110 (MW)	Gen-111 (MW)	Gen-112 (MW)	Gen-113 (MW)	Gen-116 (MW)	Gen-107 (MW)	Gen-110 (MW)	Gen-111 (MW)	Gen-112 (MW)	Gen-113 (MW)	Gen-116 (MW)
2	33.742	0.17641	0.07029	0.074479	0.084484	0.26015	0.54608	0.17642	0.070304	0.074488	0.084469	0.26018	0.54609
3	34.936	0.0011481	0.02429	-0.00184	-0.00487	-0.12908	0.08572	0.0011802	0.024295	-0.00184	-0.00487	-0.12913	0.08577
7	20.532	-0.50109	-0.08008	-0.22335	-0.26714	-1.397	-1.139	-0.50109	-0.08014	-0.22334	-0.26723	-1.397	-1.139
11	22.044	-0.079927	-0.01767	-0.03514	-0.04149	-0.19599	-0.19864	-0.079927	-0.01767	-0.03514	-0.04150	-0.19607	-0.19855
13	21.964	0.3324	0.16024	0.13762	0.15281	0.33545	1.124	0.33242	0.16026	0.13762	0.15282	0.33547	1.124
14	20.691	0.16734	0.085524	0.068802	0.075821	0.1413	0.58286	0.16735	0.085535	0.068803	0.075822	0.14129	0.58291
16	20.85	0.27669	0.12888	0.115	0.12823	0.30286	0.92001	0.2767	0.12889	0.115	0.12823	0.30278	0.92001
17	21.089	-1.328	-0.44117	-0.5697	-0.65629	32.756	-3.794	-1.328	-0.44119	-0.5698	-0.65648	32.755	-3.795
20	21.168	0.20442	0.13588	0.080957	0.085462	0.015533	0.815	0.20441	0.13587	0.080954	0.085448	0.015482	0.81502
21	20.85	0.41409	0.21672	0.16975	0.18646	0.34599	1.435	0.41409	0.21673	0.16975	0.18646	0.34593	1.435
22	21.487	0.42325	0.22155	0.1735	0.19058	0.36393	1.456	0.42326	0.22155	0.17351	0.19058	0.3639	1.456
23	22.839	-0.66814	-0.25275	-0.28345	-0.323	0.080557	-1.915	-0.66823	-0.25273	-0.28347	-0.32303	0.080539	-1.916
28	18.463	0.13753	0.078981	0.055688	0.060326	0.46697	0.50158	0.13752	0.078984	0.055685	0.060323	0.46693	0.50158
29	35.015	0.08196	0.056481	0.032272	0.033801	0.71278	0.3329	0.081951	0.056484	0.032257	0.033798	0.7128	0.33289
33	42.177	0.59022	0.2685	0.24595	0.275	0.66717	1.956	0.59024	0.26853	0.24594	0.275	0.66711	1.956
35	26.261	-0.22153	-0.11404	-0.09094	-0.1002	-0.19487	-0.78481	-0.22151	-0.11404	-0.09099	-0.10018	-0.19497	-0.78503
39	29.445	0.15404	0.18401	0.052954	0.045775	-0.16485	0.90055	0.15401	0.18401	0.05296	0.045736	-0.16498	0.90052

Table 11. Analysis of real power allocation for selected generators in the IEEE 118 bus system

41	29.445	-0.38925	0.034202	-0.18297	-0.22959	-0.89799	-0.58842	-0.38924	0.034191	-0.18297	-0.2296	-0.89814	-0.58843
43	30.24	0.50245	0.24314	0.20791	0.23076	0.47352	1.729	0.50243	0.24313	0.20792	0.23077	0.4735	1.729
44	28.649	0.57406	0.30863	0.23452	0.25662	0.45607	2.082	0.57406	0.30864	0.23453	0.25663	0.45605	2.082
45	42.177	0.28215	0.1641	0.11407	0.12332	0.20542	1.066	0.28215	0.16412	0.11406	0.12331	0.20536	1.066
47	58.889	0.23569	0.15323	0.093944	0.099664	0.152	0.93871	0.23577	0.15319	0.093967	0.099666	0.15199	0.93889
48	47.748	0.055997	0.023694	0.023554	0.026538	0.048013	0.18169	0.056017	0.023724	0.023556	0.026553	0.04797	0.18162
50	29.445	0.21457	0.12709	0.086539	0.093283	0.1485	0.82321	0.21457	0.12708	0.086535	0.093279	0.14849	0.82322
51	29.445	0.40261	0.22604	0.16355	0.17781	0.28905	1.506	0.40262	0.22604	0.16356	0.17781	0.28903	1.506
52	30.24	0.63096	0.34321	0.25738	0.28115	0.46243	2.325	0.63096	0.34321	0.25738	0.28115	0.46242	2.325
53	26.261	-0.10263	0.055608	-0.05283	-0.07115	-0.17384	-0.00468	-0.10269	0.055604	-0.05285	-0.07121	-0.17391	-0.00487
57	33.424	-0.08542	0.13265	-0.05248	-0.07895	-0.22284	0.28771	-0.085465	0.13258	-0.05248	-0.07897	-0.22301	0.28766
58	19.895	-0.31289	0.063793	-0.15073	-0.19292	-0.4379	-0.36759	-0.31304	0.063805	-0.15073	-0.19294	-0.43799	-0.36768
60	62.072	0.012021	0.17156	-0.01134	-0.03242	-0.12428	0.58579	0.011923	0.17159	-0.01138	-0.03239	-0.12441	0.58567
67	22.282	0.13199	0.10379	0.050696	0.051522	0.068946	0.59666	0.13198	0.10379	0.050696	0.051512	0.068944	0.59664
75	37.403	0.18798	-0.02875	0.092096	0.11654	0.17113	0.048409	0.18811	-0.02816	0.091987	0.1166	0.17089	0.049178
78	56.502	0.54436	0.46	0.23461	0.24055	0.25415	1.780	0.54457	0.46035	0.23476	0.2407	0.25441	1.780
79	31.036	0.37995	0.40042	0.15918	0.15374	0.17367	1.528	0.37987	0.40043	0.15914	0.15373	0.17364	1.528
82	42.973	0.8622	0.77475	0.32579	0.31954	0.41579	2.577	0.86217	0.77462	0.3258	0.31954	0.41581	2.577
83	15.916	0.31408	0.27243	0.11957	0.11858	0.14553	0.86389	0.31408	0.27244	0.11958	0.11856	0.14552	0.86388
84	87.538	0.018614	-0.17347	0.029182	0.054584	-0.03262	-0.56264	0.018548	-0.17346	0.029177	0.054564	-0.03262	-0.56274
86	16.712	-0.1309	-0.23078	-0.03578	-0.01950	-0.08321	-0.6854	-0.13092	-0.2308	-0.03580	-0.01955	-0.08323	-0.6857
88	38.198	0.87967	-0.05461	0.43983	0.54895	0.14802	-0.5368	0.87941	-0.05460	0.43979	0.54891	0.14805	-0.53752
93	95.496	-0.25741	-0.11605	-0.07175	-0.07622	-0.10564	-0.3485	-0.25755	-0.11608	-0.07176	-0.07621	-0.10566	-0.34858
94	23.874	1.668	0.63315	1.507	1.794	-0.19487	-1.373	1.6685	0.63318	1.507	1.794	-0.19489	-1.374
95	33.424	0.6563	0.80719	0.22336	0.18961	0.34821	2.309	0.65622	0.80733	0.22336	0.18955	0.34821	2.31
96	30.24	0.4655	0.60166	0.1647	0.13912	0.25282	1.886	0.46548	0.60158	0.16469	0.13909	0.25282	1.886
97	11.937	-0.19377	0.23982	-0.09554	-0.1436	-0.05865	0.77291	-0.1938	0.23974	-0.09558	-0.14365	-0.05867	0.77298
98	27.057	0.8291	0.49602	0.59536	0.68224	0.08842	0.61209	0.82889	0.49604	0.59535	0.68216	0.088447	0.6121
101	97.088	3.857	2.371	1.911	2.107	0.9018	3.569	3.857	2.371	1.911	2.107	0.90182	3.569
102	11.937	0.007438	-0.34445	0.09218	0.15069	-0.13734	-1.125	0.007336	-0.34441	0.092196	0.15065	-0.13734	-1.125
106	34.219	42.439	-0.57113	1.485	1.895	-0.54923	-2.923	42.438	-0.57107	1.485	1.895	-0.5493	-2.923
108	89.13	12.297	3.114	2.377	2.603	0.57067	1.915	12.296	3.114	2.377	2.602	0.57067	1.915
109	14.324	-1.378	12.968	17.664	20.427	-0.53203	-2.062	-1.378	12.968	17.664	20.427	-0.53203	-2.062
114	14.324	0.050762	0.069213	0.01661	0.013121	1.568	0.32816	0.050775	0.069204	0.016619	0.013128	1.567	0.32813
115	17.508	0.081997	0.050169	0.0329	0.035261	0.48282	0.30947	0.081973	0.050169	0.032889	0.035252	0.48282	0.30945
117	15.916	0.26975	0.14147	0.11056	0.1214	0.2092	0.95213	0.26977	0.14147	0.11056	0.12141	0.20917	0.95212
118	26.261	0.20535	0.22663	0.074181	0.067384	0.093782	1.021	0.20527	0.22663	0.074156	0.067356	0.093762	1.021
Total:	56.609	18.605	24.406	28.148	29.977	26.348	56.609	18.607	24.405	28.148	29.977	26.354	

Table 11. Analysis of real power allocation for selected generators in the IEEE 118 bus system (cont.)

6.1.8 Reactive power allocation results for IEEE 118 bus system

For case scenario, the real and reactive load demand from the nominal trained pattern is increased by 10%. Figure 19 shows the reactive power transfer allocation result for generator located at bus 69 calculated by the RBFN along with the result obtained through to the MNE Method for loads at buses 2, 3, 11, 13, 14, 16, 17, 20, 21 and 22 within 24 hours. The pattern used for results is same as of real power allocation. From Figure 6.7, it can be observed that the developed RBFN can allocate reactive power transfer between generators and load with very good accuracy, almost 100%. In this simulation, RBFN computes within 15ms, whereas the MNE Method took 2911ms for the calculation of same reactive power transfer allocation. As a result it can be concluded that the RBFN is more efficient in terms of computation time.

Furthermore, the final allocation of reactive power to loads at hour 12 using developed RBFN is presented in Table 12 along with the result obtained through MNE and found close match between their results. The difference of reactive power between generators in both methods is very small i.e. <0.0067Mvar.

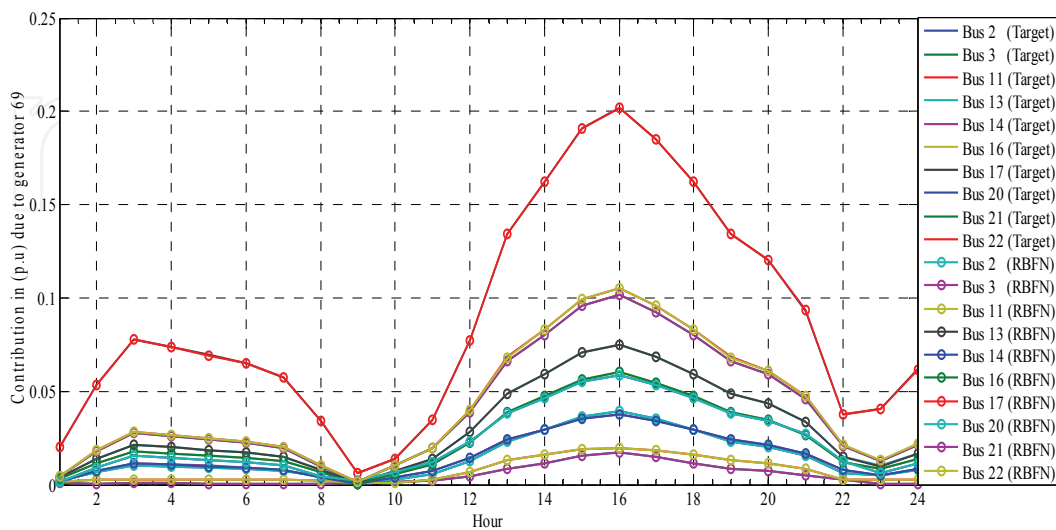

Fig. 19. Distribution of reactive power from generator at bus 69 to loads within 24 hours

Bus no.	Actual load (MVar)	RBFN Output							Modified Nodal Equations Method					
		Gen-107 (MVar)	Gen-110 (MVar)	Gen-111 (MVar)	Gen-112 (MVar)	Gen-113 (MVar)	Gen-116 (MVar)	Gen-107 (MVar)	Gen-110 (MVar)	Gen-111 (MVar)	Gen-112 (MVar)	Gen-113 (MVar)	Gen-116 (MVar)	
2	22.442	0.006014	-0.06158	0.00882	0.017496	0.36319	-0.2018	0.00603	-0.06151	0.00884	0.017491	0.36318	-0.2017	
3	22.282	0.070593	0.02632	0.02990	0.034195	0.11366	0.21179	0.07059	0.02634	0.02998	0.034208	0.11366	0.21241	
7	22.282	0.3418	0.30944	0.1272	0.12409	-0.45274	1.656	0.34178	0.30957	0.12725	0.12405	-0.45274	1.655	
11	22.839	0.03888	0.04396	0.01367	0.01214	-0.09954	0.21848	0.03895	0.04395	0.01364	0.012157	-0.09952	0.21858	
13	22.76	0.083069	-0.08600	0.04681	0.066985	0.78692	-0.1534	0.08310	-0.08600	0.04681	0.066996	0.78688	-0.1536	
14	21.487	0.057507	-0.03771	0.03022	0.041412	0.42551	-0.0309	0.05756	-0.03767	0.03027	0.041406	0.42552	-0.0309	
16	21.487	0.058085	-0.07633	0.03432	0.050523	0.67031	-0.1639	0.05811	-0.07632	0.03432	0.050547	0.67026	-0.1639	
17	21.884	0.23004	0.56429	0.05054	0.002111	18.211	2.346	0.22997	0.56432	0.05057	0.002159	18.212	2.348	
20	22.919	0.1559	-0.01169	0.07312	0.091547	0.6119	0.2164	0.15603	-0.01170	0.07315	0.091584	0.61188	0.21644	
21	22.76	0.15113	-0.08834	0.07843	0.10628	0.94974	-0.0719	0.15116	-0.08837	0.07845	0.10632	0.9498	-0.0719	
22	22.362	0.15457	-0.09030	0.08020	0.10867	0.92085	-0.0853	0.15456	-0.09031	0.08021	0.1087	0.92084	-0.0854	
23	21.248	0.028327	0.24962	-0.01151	-0.04082	-0.38525	0.95643	0.02828	0.24965	-0.01150	-0.04088	-0.3852	0.95638	
28	22.68	0.069909	-0.02159	0.03437	0.044734	0.59457	0.03467	0.06986	-0.02162	0.03436	0.04475	0.59454	0.03472	
29	22.282	0.068016	-0.00258	0.03164	0.039312	0.64619	0.10095	0.06805	-0.00250	0.03164	0.039349	0.64619	0.10104	
33	31.036	0.10281	-0.17039	0.06418	0.097457	1.096	-0.4001	0.10277	-0.17036	0.06419	0.097468	1.096	-0.4	
35	23.078	-0.063832	0.05199	-0.03457	-0.04824	-0.3362	0.05991	-0.0638	0.05203	-0.03457	-0.04825	-0.33624	0.06035	
39	22.282	0.31646	0.07433	0.13858	0.16323	0.52581	0.82355	0.3163	0.07434	0.13864	0.16325	0.52581	0.82333	
41	22.282	0.50263	0.3398	0.19844	0.20875	0.23008	2.061	0.50257	0.33997	0.19845	0.20874	0.23008	2.060	
43	22.282	0.12944	-0.12873	0.07239	0.10316	0.61613	-0.2036	0.12945	-0.12871	0.07240	0.10316	0.61614	-0.2039	
44	22.282	0.23245	-0.11355	0.11843	0.15832	0.55532	0.02799	0.23244	-0.11352	0.11843	0.15837	0.55533	0.02814	
45	30.24	0.14994	-0.04177	0.07327	0.094882	0.26658	0.12454	0.14991	-0.04186	0.073299	0.094987	0.26655	0.12442	
47	46.156	0.17256	-0.01586	0.08128	0.10203	0.22298	0.23989	0.17253	-0.01587	0.081271	0.10205	0.22294	0.23954	
48	30.24	0.0083913	-0.01704	0.00552	0.008596	0.026759	-0.0438	0.00826	-0.01704	0.00550	0.008619	0.026778	-0.0437	
50	22.282	0.1219	-0.02881	0.05915	0.076116	0.17817	0.12473	0.12205	-0.02880	0.059164	0.076136	0.17818	0.12482	

Table 12. Analysis of reactive power allocation for selected generators in the IEEE 118 bus system

51	22.282	0.19109	-0.06871	0.09492	0.12455	0.29682	0.1205	0.19108	-0.06869	0.09494	0.12458	0.2968	0.12057
52	22.282	0.26658	-0.12054	0.13482	0.17936	0.43472	0.08783	0.26662	-0.12039	0.13488	0.17942	0.43477	0.08748
53	22.282	0.26907	0.1425	0.11017	0.12086	0.20019	0.98043	0.26922	0.14249	0.11021	0.12087	0.20023	0.98073
57	30.24	0.46583	0.21367	0.19396	0.2167	0.37681	1.584	0.46596	0.21368	0.19399	0.21671	0.37688	1.584
58	30.24	0.52403	0.31769	0.21048	0.22596	0.3542	2.042	0.52395	0.31771	0.21051	0.226	0.35413	2.043
60	38.198	0.46826	0.17973	0.19827	0.22563	0.39709	1.499	0.46806	0.17974	0.1983	0.22566	0.39709	1.500
67	22.282	0.14639	0.0104	0.066526	0.08103	0.16252	0.31679	0.14638	0.0104	0.066528	0.08104	0.16252	0.31678
75	22.282	-0.28563	-0.17173	-0.11374	-0.12204	-0.18192	-0.9441	-0.2856	-0.17227	-0.11379	-0.12211	-0.18193	-0.9455
78	36.607	0.68374	0.15851	0.3118	0.36798	0.36303	0.61565	0.68472	0.15851	0.31193	0.36825	0.36319	0.61571
79	25.466	0.71643	0.21628	0.32115	0.37354	0.37132	0.8582	0.71669	0.21646	0.32128	0.3736	0.37138	0.85835
82	29.445	1.215	0.18154	0.54397	0.65232	0.45164	0.53679	1.215	0.18158	0.54398	0.65233	0.45166	0.53681
83	30.24	0.41881	0.057094	0.18851	0.22664	0.14244	0.13402	0.41883	0.057092	0.18848	0.22665	0.14244	0.13402
84	29.445	-0.50926	-0.19681	-0.21449	-0.24384	-0.1796	-0.5477	-0.5092	-0.19685	-0.2145	-0.24384	-0.1796	-0.5476
86	30.24	-0.50221	-0.14519	-0.21664	-0.25197	-0.15772	-0.34537	-0.5023	-0.1451	-0.21667	-0.25204	-0.15773	-0.3453
88	30.24	-1.130	-0.67583	-0.4443	-0.47638	-0.42418	-1.861	-1.130	-0.6758	-0.44431	-0.47644	-0.42418	-1.861
93	29.445	-0.06821	0.16569	-0.03630	-0.06254	0.0097741	0.29743	-0.0682	0.16568	-0.03632	-0.06256	0.0097718	0.29774
94	28.649	-0.71453	1.372	-0.21517	-0.41236	-0.27547	-0.48801	-0.7145	1.372	-0.21517	-0.41237	-0.27545	-0.4876
95	30.24	1.539	0.37092	0.67386	0.79238	0.43411	0.66494	1.539	0.37096	0.67379	0.79239	0.43415	0.66502
96	27.853	1.172	0.32145	0.51324	0.59942	0.39961	0.77962	1.172	0.32148	0.51324	0.59942	0.39965	0.77957
97	31.036	0.89174	0.47193	0.37349	0.41072	0.39477	1.548	0.89179	0.47195	0.37348	0.41077	0.39481	1.548
98	22.282	0.59015	0.72166	0.32989	0.33026	0.11952	0.20614	0.59018	0.72167	0.32991	0.33027	0.11959	0.20652
101	19.895	2.097	0.47469	1.034	1.226	0.15317	-1.702	2.096	0.47475	1.034	1.226	0.15325	-1.703
102	22.282	-0.99718	-0.23722	-0.4167	-0.48922	-0.2573	-0.56698	-0.9971	-0.2371	-0.41669	-0.48921	-0.25731	-0.5664
106	20.691	3.952	1.101	-1.209	-1.611	-0.39309	-0.02700	3.953	1.101	-1.209	-1.610	-0.39313	-0.0261
108	16.712	2.931	0.77924	1.349	1.583	-0.042595	-1.570	2.931	0.77967	1.349	1.583	-0.042592	-1.570
109	18.303	-2.189	17.388	-0.87222	-2.934	-0.071792	1.069	-2.189	17.381	-0.87225	-2.934	-0.071785	1.069
114	22.282	0.13799	0.036191	0.060094	0.070396	1.404	0.34794	0.13803	0.03614	0.060138	0.070399	1.404	0.34807
115	21.487	0.05025	-0.00954	0.02414	0.030845	0.48589	0.045807	0.05031	-0.0094	0.024152	0.030837	0.48589	0.04580
117	22.282	0.10023	-0.05713	0.05187	0.070141	0.68789	-0.02434	0.10024	-0.0571	0.051878	0.070164	0.68786	-0.0244
118	19.895	0.40966	0.092916	0.18067	0.21309	0.30092	0.6676	0.40954	0.09295	0.18067	0.21317	0.30094	0.66786

Table 12. Analysis of reactive power allocation for selected generators in the IEEE 118 bus system (cont.)

7. Conclusion

The proposed real and reactive power allocation methods have been tested in this chapter for 25 bus and IEEE 118 bus systems. Table 13 shows the advantages and improvement in the computation time of the developed ANN and RBFN vs. MNE Method. In the 25 bus system, the developed ANN is compared with the MNE Method while for large system like IEEE 118, RBFN is compared with MNE because for large bus system ANN requires large number of networks and hence large computational time for training. It is observed that, as the number of buses increase (i.e. IEEE 118) the computational time in the MNE Method increases proportionally (i.e. for real power allocation is 3,000 msec and for reactive power is 2,911 msec) while for developed RBFN it remain almost same (i.e. for real power allocation is 15 msec and for reactive power is 15 msec) as shown in Table 13.

Test System	Computational time in msec					
	MNE		ANN		RBFN	
	Real Power Allocation	Reactive Power Allocation	Real Power Allocation	Reactive Power Allocation	Real Power Allocation	Reactive Power Allocation
25 bus	1314	908	45	45	---	---
IEEE 118 bus	3000	2911	---	---	15	15

Table 13. Comparative computational time for MNE, ANN, and RBFN methods for different bus system

8. References

- Abdullah, S.S (2008). *A Short Course in Artificial Neural Network*, Desktop, ISBN, Malaysia
- Bialek, J. ; (1996). Tracing the flow of electricity, *IEE Proceedings Generation, Transmission & Distribution*, Vol.,143 No., 4 (313-320)
- Chu, W.; Chen, B. & Liao, C. (2004). Allocating the Costs of Reactive Power Purchased in an Ancillary Service Market by Modified Y-Bus Matrix Method, *IEEE Transaction on Power system*, Vol.,19 No., 1 (174-178)
- Cheng, J.W.M. (1998). Studies of Bilateral Contracts with Respects to Steady-State Security in a Deregulated Environment, *IEEE Transaction on Power system*, Vol.,13 No.,3 (1020-1025)
- Haque, R. ; & Chowdhury, N. (2005). An Artificial Neural Network Based Transmission Loss Allocation For Bilateral Contracts, *Proceedings of the 18th Annual Canadian Conference on Electrical and Computer Engineering*, pp.2197-2201, Canada, May 2005
- Tsoukalas, LH.; & Uhrig, RE. (1997). *Fuzzy and Neural Approaches in Engineering*, Wiley, ISBN, New York
- Reta, R. ; & Vargas,A . (2001). Electricity Tracing and Loss Allocation Methods Based on Electric Concepts, *IEE Proceedings Generation, Transmission & Distribution*, Vol.,148 No., 6 (518-522)

IntechOpen



Artificial Neural Networks - Industrial and Control Engineering Applications

Edited by Prof. Kenji Suzuki

ISBN 978-953-307-220-3

Hard cover, 478 pages

Publisher InTech

Published online 04, April, 2011

Published in print edition April, 2011

Artificial neural networks may probably be the single most successful technology in the last two decades which has been widely used in a large variety of applications. The purpose of this book is to provide recent advances of artificial neural networks in industrial and control engineering applications. The book begins with a review of applications of artificial neural networks in textile industries. Particular applications in textile industries follow. Parts continue with applications in materials science and industry such as material identification, and estimation of material property and state, food industry such as meat, electric and power industry such as batteries and power systems, mechanical engineering such as engines and machines, and control and robotic engineering such as system control and identification, fault diagnosis systems, and robot manipulation. Thus, this book will be a fundamental source of recent advances and applications of artificial neural networks in industrial and control engineering areas. The target audience includes professors and students in engineering schools, and researchers and engineers in industries.

How to reference

In order to correctly reference this scholarly work, feel free to copy and paste the following:

S.N. Khalid, M.W. Mustafa, H. Shareef and A. Khairuddin (2011). Application of ANN to Real and Reactive Power Allocation Scheme, Artificial Neural Networks - Industrial and Control Engineering Applications, Prof. Kenji Suzuki (Ed.), ISBN: 978-953-307-220-3, InTech, Available from:
<http://www.intechopen.com/books/artificial-neural-networks-industrial-and-control-engineering-applications/application-of-ann-to-real-and-reactive-power-allocation-scheme>

INTECH
open science | open minds

InTech Europe

University Campus STeP Ri
Slavka Krautzeka 83/A
51000 Rijeka, Croatia
Phone: +385 (51) 770 447
Fax: +385 (51) 686 166
www.intechopen.com

InTech China

Unit 405, Office Block, Hotel Equatorial Shanghai
No.65, Yan An Road (West), Shanghai, 200040, China
中国上海市延安西路65号上海国际贵都大饭店办公楼405单元
Phone: +86-21-62489820
Fax: +86-21-62489821

© 2011 The Author(s). Licensee IntechOpen. This chapter is distributed under the terms of the [Creative Commons Attribution-NonCommercial-ShareAlike-3.0 License](#), which permits use, distribution and reproduction for non-commercial purposes, provided the original is properly cited and derivative works building on this content are distributed under the same license.

IntechOpen

IntechOpen