

We are IntechOpen, the world's leading publisher of Open Access books Built by scientists, for scientists

4,800

Open access books available

122,000

International authors and editors

135M

Downloads

Our authors are among the

154

Countries delivered to

TOP 1%

most cited scientists

12.2%

Contributors from top 500 universities



WEB OF SCIENCE™

Selection of our books indexed in the Book Citation Index
in Web of Science™ Core Collection (BKCI)

Interested in publishing with us?
Contact book.department@intechopen.com

Numbers displayed above are based on latest data collected.

For more information visit www.intechopen.com



High-Quality Telemedicine Using Digital Video Transport System over Global Research and Education Network

Shuji Shimizu¹, Koji Okamura², Naoki Nakashima³, Yasuichi Kitamura⁴,
Nobuhiro Torata⁵, Yasuaki Antoku⁶, Takanori Yamashita⁷,
Toshitaka Yamanokuchi⁸, Shinya Kuwahara⁹ and Masao Tanaka¹⁰

^{1,2,3,5,6,7,8,9,10}*Telemedicine Development Center of Asia, Kyushu University Hospital,*

¹*Department of Endoscopic Diagnostics and Therapeutics, Kyushu University Hospital*

²*Research Institute for Information Technology, Kyushu University*

^{3,6,7,8}*Department of Medical Informatics, Kyushu University Hospital*

⁴*National Institute of Information and Communications Technology*

⁹*Kyushu Electric Power Company*

¹⁰*Department of Surgery and Oncology, Kyushu University Graduate School of Medical*

Sciences

Japan

1. Introduction

Extraordinary advances in communication and information technologies have brought about dramatic changes in our daily lives, including the overwhelming prevalence of emails, web homepages, and mobile phones, all of which are now indispensable both at home and at work. The medical community is no exception, in that the emergence of electronic recording systems, picture archiving and communication systems (PACS), and various digitalized medical equipment has had an enormous impact on clinical practice. Associated with these large waves of technological development, telemedicine has recently been gaining in popularity. It covers a variety of fields including home health care, remote patient monitoring, telementoring and telesurgery, and also encompasses a wide range of sectors from rural health to advanced treatments (Anvari et al., 2005; Hazin et al., 2010; Hu et al., 2009).

However, many doctors are still unfamiliar or unhappy with telemedicine, and the applications are limited to a very small part of daily practice and medical education. What are the reasons for this? We believe there are three key factors. First, the quality of images is critical for accurate diagnosis and appropriate treatment, yet conventional telemedicine often transmits compressed images, inevitably with degraded quality (Demartines et al., 2000; Rabenstein et al., 2002). This is especially true when sending images of surgery and various other medical procedures, because of the limitations of the transmittable bandwidth. Doctors will never be satisfied with these degraded videos, since the fine anatomy of thin membranes or tiny vessels is not clearly distinguishable. The second reason relates to cost. To participate in telemedicine, special teleconferencing equipment needs to be purchased,

and this could lead to major reservations in many hospitals (Augestad et al., 2009). Third, the installation and administration of the system is difficult for many doctors and they usually do not have the time to struggle with it. In addition, the medical community is often physically separated from technological departments and they tend not to know the right technical people who would be able to assist them.

A completely new telemedicine system comprising two key technologies, namely, a digital video transport system (DVTS) and the research and education (R&E) network, has been designed to solve all these problems. Here, we introduce the system in sufficient detail to enable readers to set it up themselves and to join our worldwide activities that now cover a variety of medical application fields.

2. Digital Video Transport System (DVTS)

2.1 What is DVTS?

DVTS is software developed by the “WIDE Project” in Japan that can transfer digital video (DV) signal through Internet Protocol (IP) networks using video cameras connected to personal computers (PCs) with an IEEE 1394 cable (Ogawa et al., 1999). By sending and receiving DV streams via the Internet, which employs differentiated data transmission, such a system has the ability to send full resolution videos to remote stations.

2.2 Advantages and Disadvantages of DVTS

The advantages of DVTS are as follows.

1. High quality transmitted images:
DVTS can preserve the image quality by skipping the compression process. This means that the transmitted video is the same quality as the original source.
2. Low cost:
Although it is powerful and internationally authorized by the International Telecommunication Union, DVTS software is free of charge. Moreover, regular PCs and DV cameras found in a hospital or at home can be used for setting up the system without the need for purchasing any special videoconferencing equipment.
3. Minimal time delay:
This can also be achieved because of the omission of the complicated and time-consuming compression process. The time delay under well prepared conditions is only 0.3 sec between international connections.

However, the following issues must also be considered.

1. As much as 30 Mbps network bandwidth is required for each DV stream. Furthermore, not only must the bandwidth be large enough, but there must also be a very stable network for the DVTS to work properly. Quality of service for Internet is very important.
2. There are no sound adjustment functions in the DVTS software. In contrast with conventional videoconferencing systems, which include a sound mixer or echo canceller, DVTS is a simple system merely for sending video together with sound. Microphones and other means to control sound need to be prepared and adjusted separately.

2.3 DVTS software

The DVTS can be installed on a PC running Windows, Mac, or Linux OS platforms from <http://www.sfc.wide.ad.jp/DVTS/index.html>. DVTS for Windows 0.0.2 (Development build) is the latest version for Windows XP as of June 2010.

The setup window depicted in Fig. 1 is displayed when the DVTS software is executed. For sender setup, input the IP address for the destination at (C) and select the DV device at (D). The default port is 8000 and the settings at (A) need to be changed.

Check the preview monitor at (G) and push “Start send” at (H) to start sending.

For receiver setup, check monitor output at (J), fix the settings at (I), and push “Start Receive” at (M) to start receiving. Use the default port 8000, unless there is a reason for another assignment.

“IEEE1394 Output” at (L) is used to export the DV stream to a DV device (Analog - digital video converter (ADVC), etc.) connected to the port. Another DV device needs to be prepared for the receiver PC, since it is impossible to share the DV device connected to the sender PC.

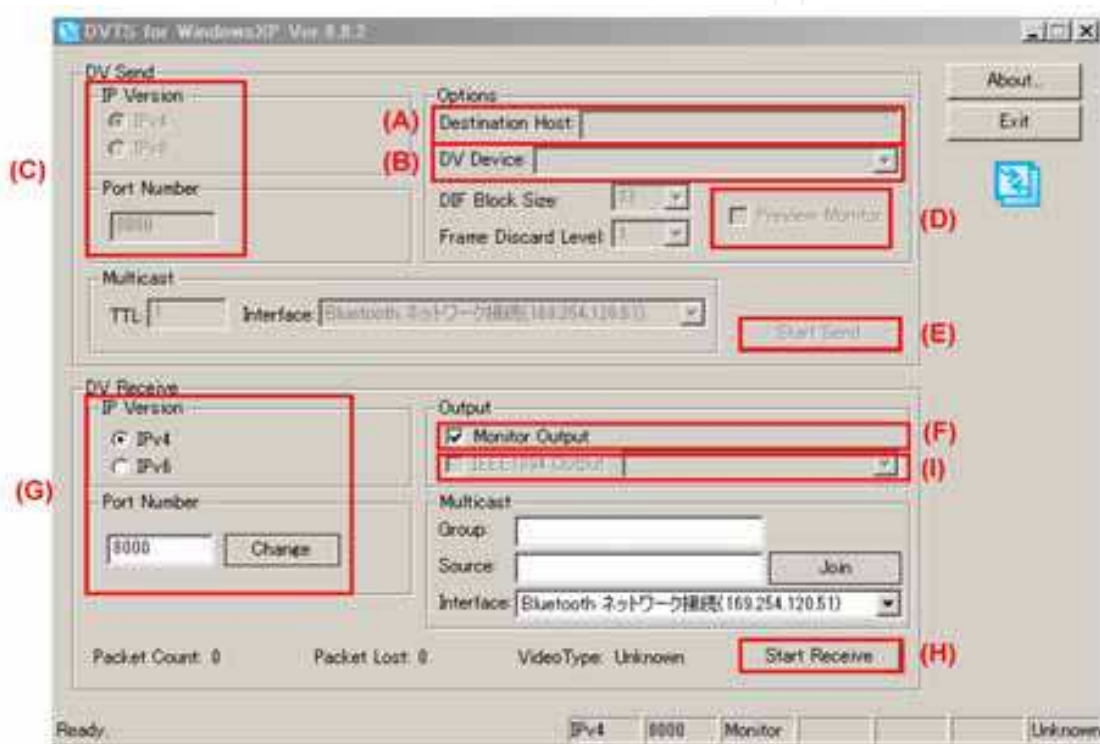

Fig. 1. DVTS window detail

2.4 Equipment and local setup for DVTS

2.4.1 Minimal configuration

Fig. 2 shows the minimal configuration for the DVTS. A DV camera with external microphone is connected to a PC through an IEEE1394 interface for DV image transmission.

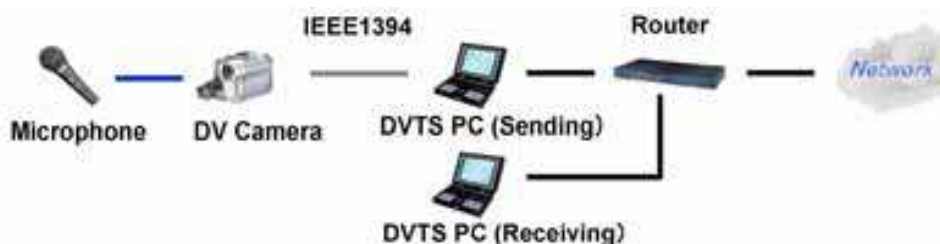

Fig. 2. Minimal configuration for DVTS setup

Although the minimal configuration should be good enough to perform the first local test to get used to the system, it does not provide adequate performance for use in teleconferencing events, because of the following problems.

1. **IEEE1394 cable:**

The IEEE1394 cable benefits from the advantages of a direct connection between the DV camera and PC in terms of ease of setting up and simple configuration, but the disadvantages include the limitation of cable length, problems with unplugging because of the plug form, and unavailability of audio and visual mixing.

2. **Sound level adjustment:**

Audio trouble is often caused by unsatisfactory audio devices. With the minimal configuration, it is difficult to control the sound level, since the sound comes from the microphone, which is connected via an external microphone plug, and most consumer products do not have a control knob for audio level adjustment.

2.4.2 Standard configuration

As the number of conferences increases at various locations, setting up new member institutions is becoming one of the primary foci of our activities. Poor preparation of the sound system at one site could ruin the entire teleconference because of an uncomfortable echo or unsmooth communications. Sound quality, therefore, is as important a factor as video quality. In December 2007, we proposed a standard configuration for the DVTS as illustrated in Fig. 3. The standard configuration incorporates our complete knowledge gained from more than one hundred events with three hundred connected sites. Using this configuration, greatly improved teleconferences in terms of both video and sound quality, can be performed compared with the minimal setup.

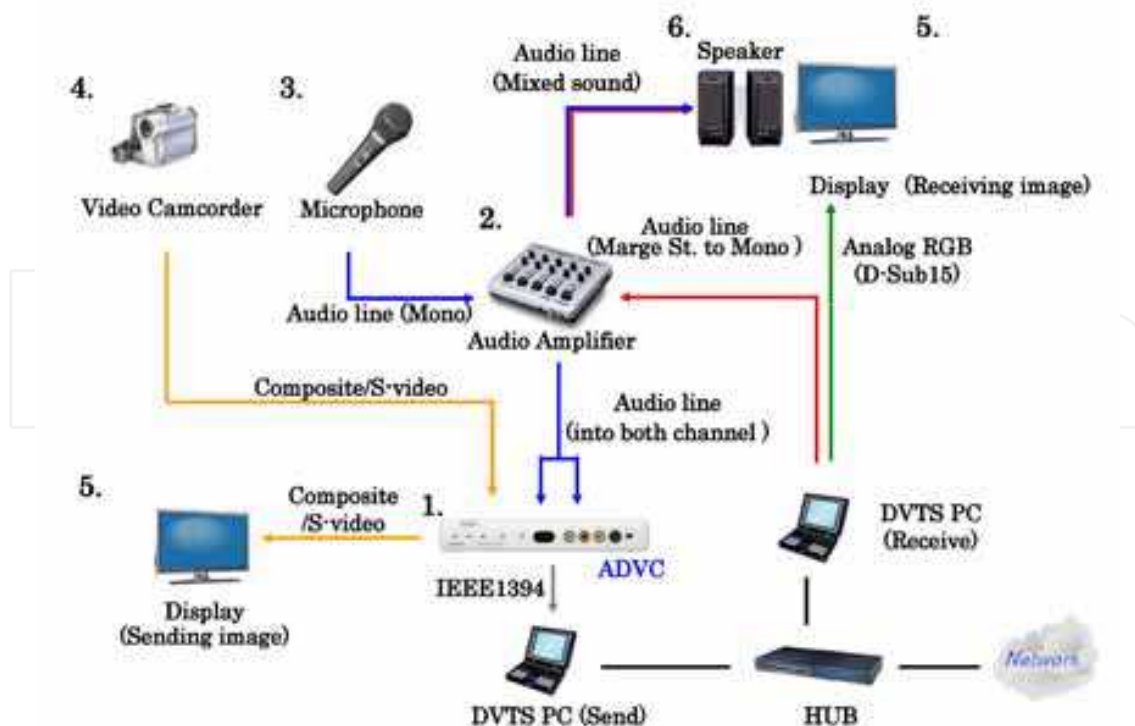

Fig. 3. Standard configuration: 1. Analog-Digital Video Converter (ADVC), 2. Audio amplifier, 3. Microphone, 4. Video camera, 5. Display, 6. Loud speaker

The areas improved are the following.

1. Audio and visual sources are separately connected to the ADVC.
2. Various image inputs from video cameras or medical devices are supported without the use of IEEE1394.
3. Sound echo is reduced by using the “minus one sound” setting.

“Minus one sound” is the fundamental sound setting method for teleconferencing. A configuration that can control transmission and reception of sound sources separately is crucial for avoiding echo noise. Fig. 4 illustrates the “minus one sound” setting. The sound source from the microphone (5) is connected to the ADVC as the sender sound (8). On the other hand, both sound sources (microphone and reception sound (4)) are connected to the loudspeakers (7).

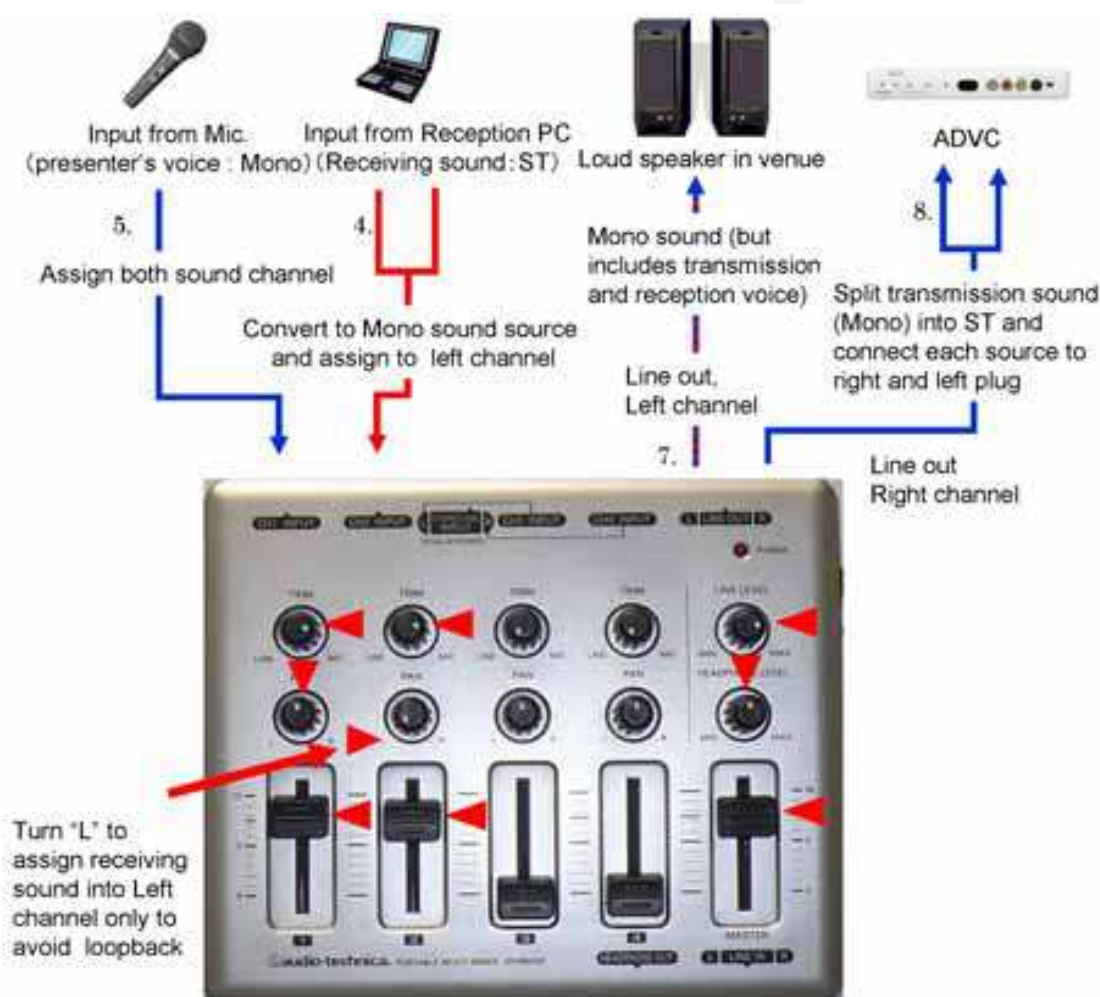

Fig. 4. Configuration diagram for setting audio

2.5 Multi-connection for DVTS

2.5.1 Multi-point control unit (MCU) for DVTS

Currently, all DVTS applications are implemented based on RFC 3189 and 3190, which are international standards for video and audio formats, respectively, for transmitting DV data over the Internet. This means that applications have the ability to transmit DV data to a specified IP address, but do not have features for session control or multi-party connections

as in H.323. Therefore, when a user starts transmitting DV data, the session begins even if the receiver is not yet ready, because of the lack of standard session control for DVTS. Of course, an implementation of the MCU (Multi-Point Control Unit) for DVTS is possible, even though this is not a standard session control and is incompatible with other MCUs. A connection between multiple sites using DVTS had long since been awaited when the new technological breakthrough was introduced at the end of 2004. We successfully set up our first three-site connection using a commercially available MCU for DVTS, the QualImage/ Quatre system (Information Services International-Dentsu, Ltd., Tokyo, Japan). The DV image transmitted from each station is digitally merged at the server, and the combined image is sent back to all stations. Once connected, participants at all sites can communicate in real-time with all other stations thereby enabling interactive discussions.

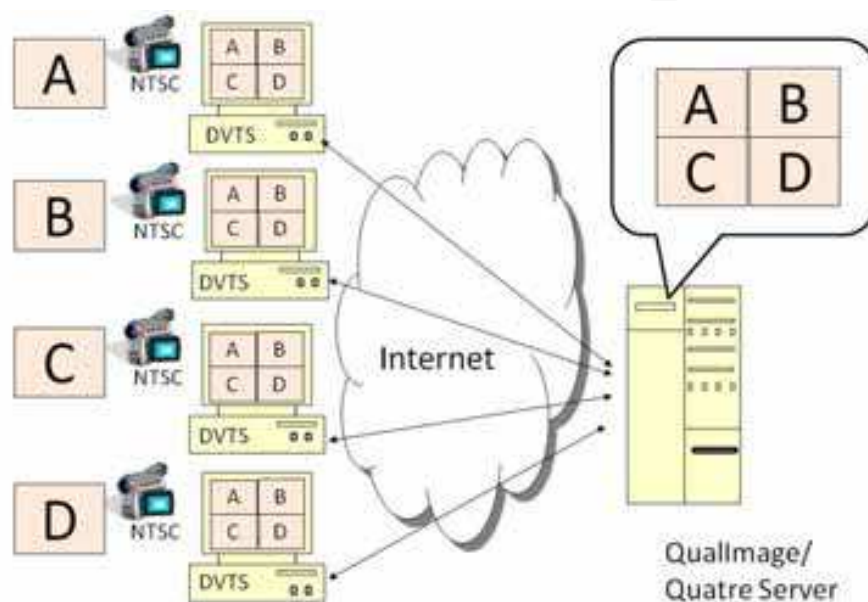

Fig. 5. Mechanism provided by QualImage/ Quatre system

However, users must learn how to use the MCU carefully. Quatre runs on Linux and only uses 16 bit Audio and NTSC Video signals, as determined by its implementation. Fixing the audio and video format in this way is reasonable in order to achieve fast processing of the multiple DVTS streams under non-standard procedures. This is in contrast to a standard MCU that has the ability to resize multiple screens and is compatible with various formats resulting in the consumption of much more CPU power and poor performance. Quatre, which is the current version in use, has a web interface and a multi-party session using DVTS can be started immediately after inputting the IP addresses for the transmitting and receiving PCs.

2.5.2 Common audio-visual problems in multi-station setup

The following issues must be carefully considered in a multi-station setting. These problems do not occur in a one-to-one connection without Quatre.

1. Video format:

TV signal can have one of three formats, NTSC (National Television System Committee), PAL (Phase Alternating Line) and SECAM (Séquentiel couleur à mémoire), but Quatre supports only NTSC. At the receiving end, this problem does not occur

because PCs support all TV signal decoding, but at the transmission end, all stations must have an NTSC camera available.

2. Audio format:

Loss of audio transmission is encountered because of incompatibility of the audio format between DV and Quatre. Because there are two audio formats, 12 bit/ 32 kHz and 16 bit/ 48 kHz in DV signals, but Quatre supports only 16 bit, no sound is audible from a station sending 12 bit audio format.

2.6 Security of patient privacy

Protecting patient privacy is of the utmost importance during live demonstrations or tele-consultations. IPsec/ VPN is a suitable means for encryption during transmission, with the performance of the processing IPsec determined by the quality of the VPN hardware for processing the encryption. In addition, all the VPN equipment should be the same model from a single vendor, because the session initiation procedure differs among IPsec/ VPNs. For our own activities, we used an AR550S (AR750S is the corresponding international model) from Allied Telesis K.K., Japan, as the IPsec VPN router. The AR550S has special hardware for IPsec and the throughput is about 150 Mbps. Thus, one AR550S can process two bi-directional DVTS streams. The setup of these routers can be done remotely once they are connected online.

3. Research and education network

3.1 What is the “research and education network”?

When the Internet service started, all the networks were for research and education activities. In 1989, the first commercial Internet service provider, UUNET, was established and the Internet Services Provider (ISP) service became popular. After the National Center for Supercomputing Applications (NCSA) released Mosaic, the first sophisticated web browser, those responsible for communication realized that a testbed for research and education was still required to provide advanced technologies of the Internet in a non-profit testbed environment. At that time, the testbed project was known as the next generation Internet (NGI), and was being championed by national governments. The first NGI testbed, established by the Group of Seven (G7), was called the Global Interoperability for Broadband Networks (GIBN). GIBN was a collaboration project between the commercial ISPs and government networks. However, owing to differences in the management policies, it became clear that a research and education environment had to be established solely by non-profit organizations or governments. The very high-performance Backbone Network Service (vBNS) (US) and TEN-34 (EU) were the first next generation Internet testbed environments or R&E networks.

In R&E networks, the backbone network is based on advanced technologies and generally provides excessive bandwidth. In about 1997, while regular Internet users were accessing the Internet at 28.8 Kbps, the R&E networks were providing 622 Mbps or more. The advanced Internet technologies, such as protocols or applications, deployed or developed on the R&E networks, are later incorporated for regular use. Border Gateway Protocol (BGP) routing, multicast Border Gateway Protocol (mBGP) routing, Internet Protocol Version 6 (IPv6), and video transmission over IP are all good examples of this.

R&E networks are typically managed on an institutional basis. Most of the customers and researchers are not concerned with payment. Nevertheless, because of the institutional

based management, technical support for such R&E networks is often only provided to the edge of the individual campus networks. In other words, customers have to maintain their own circuits. Use of an R&E network requires close collaboration between the network researchers and local engineers.

3.2 Major networks world-wide

R&E networks are generally managed either by non-profit organizations or by one of the divisions in the government and can be divided into two categories. One is the national research and education network (NREN), while the other is the international research and education network. The international networks provide interconnectivity for the NRENs and other international R&E networks.

In fact, the major international R&E networks are APAN, TEIN3, Internet2 Network, GEANT2, and RedCLARA. These international R&E networks connect the NRENs or regional networks in their areas.

3.2.1 APAN (<http://www.apan.net>)

The Asia-Pacific Advanced Network (APAN) provides interconnectivity for the NRENs in the Asia Pacific area. Table 1 lists the NRENs of APAN members.

NREN	Country/ Region	URL
AARNET	Australia	http://www.aarnet.edu.au
CERNET	China	http://www.edu.cn/english_1369/index.shtml
CSTNET	China	http://www.cstnet.net.cn/english/index.htm
SINET3	Japan	http://www.sinet.ad.jp/?set_language=en
JGN2plus	Japan	http://www.jgn.nict.go.jp/english/index.html
MAFFIN	Japan	http://nausicaa.maffin.ad.jp/Welcome.html
ThaiREN	Thailand	www.thairen.net.th/NewThaiRen/Thai/index_th.php
ThaiSARN3	Thailand	http://thaisarn.nectec.or.th/htmlweb/index.php
UniNet	Thailand	http://www.uni.net.th/UniNet/Eng/index_eng.php
KOREN	Korea	http://www.koren.kr/koren/eng/index.html
KREONET*	Korea	http://www.kreonet.re.kr/english
TANET2	Taiwan	http://www.tanet2.tw
TWAREN	Taiwan	http://www.twaren.net/english
ASGC	Taiwan	http://www.twgrid.org
PREGINET	The Philippines	http://www.pregi.net
HARNET	Hong Kong	http://www.jucc.edu.hk/jucc/harnet.html
LEARN	Sri Lanka	http://www.ac.lk
VINAREN	Vietnam	http://english.vinaren.vn
KAREN	New Zealand	http://www.karen.net.nz/home
SingAREN	Singapore	http://www.singaren.net.sg
NREN	Nepal	http://www.nren.net.np
MYREN	Malaysia	http://www.myren.net.my
PERN	Pakistan	http://www.pern.edu.pk
ERNET	India	http://www.ernet.in/index.html

Table 1. List of NRENs in APAN *International part is known as KREONET2.

APAN provides the transit service for other international R&E networks (Fig. 6).

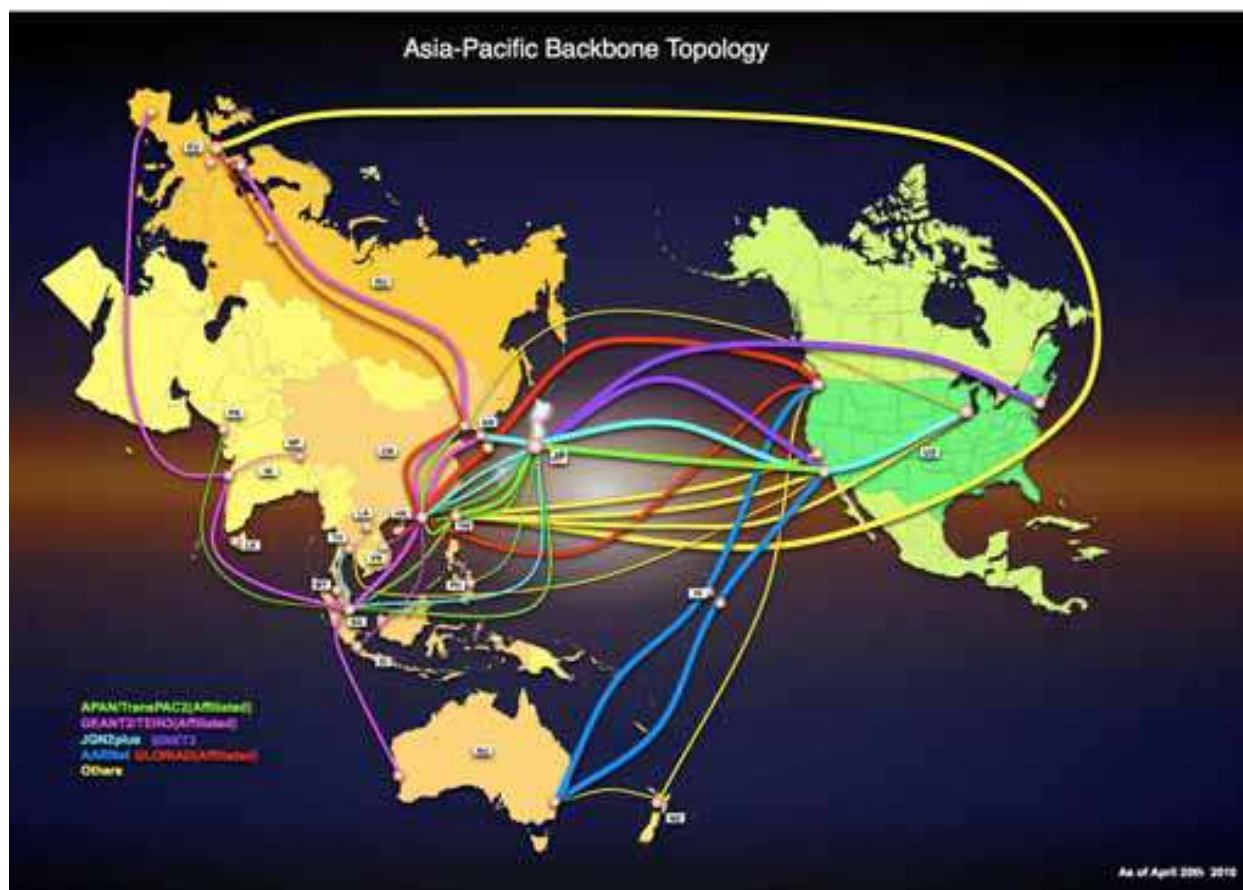

Fig. 6. R&E network map in the Asia-Pacific area (<http://www.jp.apan.net/NOC/>)

3.2.2 TEIN3

The Trans-Eurasia Information Network third generation (TEIN3) provides interconnectivity for the NRENs in South and Southeast Asia. TEIN3 also provides a transit service at Mumbai, Singapore, Hong Kong and Beijing with APAN and GEANT2 (Fig. 7).

3.2.3 Internet2 network

The Internet2 network (<http://www.internet2.edu>) provides interconnectivity for the regional networks and universities in the USA (Fig. 8). Its members represent a wide range of research and academic disciplines from over 300 member institutions, and the complete member list is available at <http://www.internet2.edu/resources/listforweb.pdf>. The Internet2 network has some international exchange points and a direct connection with the international R&E networks and direct circuits of NRENs. Its international partner organizations are listed at <http://internet2.edu/international/partners/>.

3.2.4 GÉANT2

GÉANT2 (<http://www.geant2.net>) is the second generation of ultra high speed international networks in Europe. It connects NRENs across 34 countries (Fig. 9). Since each NREN connects research and educational institutions within its own country, GÉANT2

provides connectivity to more than 30 million research and educational end users in over 3,500 institutions across Europe. The details of these NRENs are available at <http://www.geant2.net/server/show/nav.00d009001>.

3.2.5 RedCLARA

RedCLARA (<http://www.redclara.net/index.php?lang=en>) provides interconnectivity in Central and South America and is operated by Cooperacion Latino Americana de Redes Avanzadas (CLARA). RedCLARA has a collaboration with the ALICE project in Europe and the WHREN project in USA (Fig. 10). Details of the member countries are listed at http://www.redclara.net/index.php?option=com_content&task=view&id=33&Itemid=217.

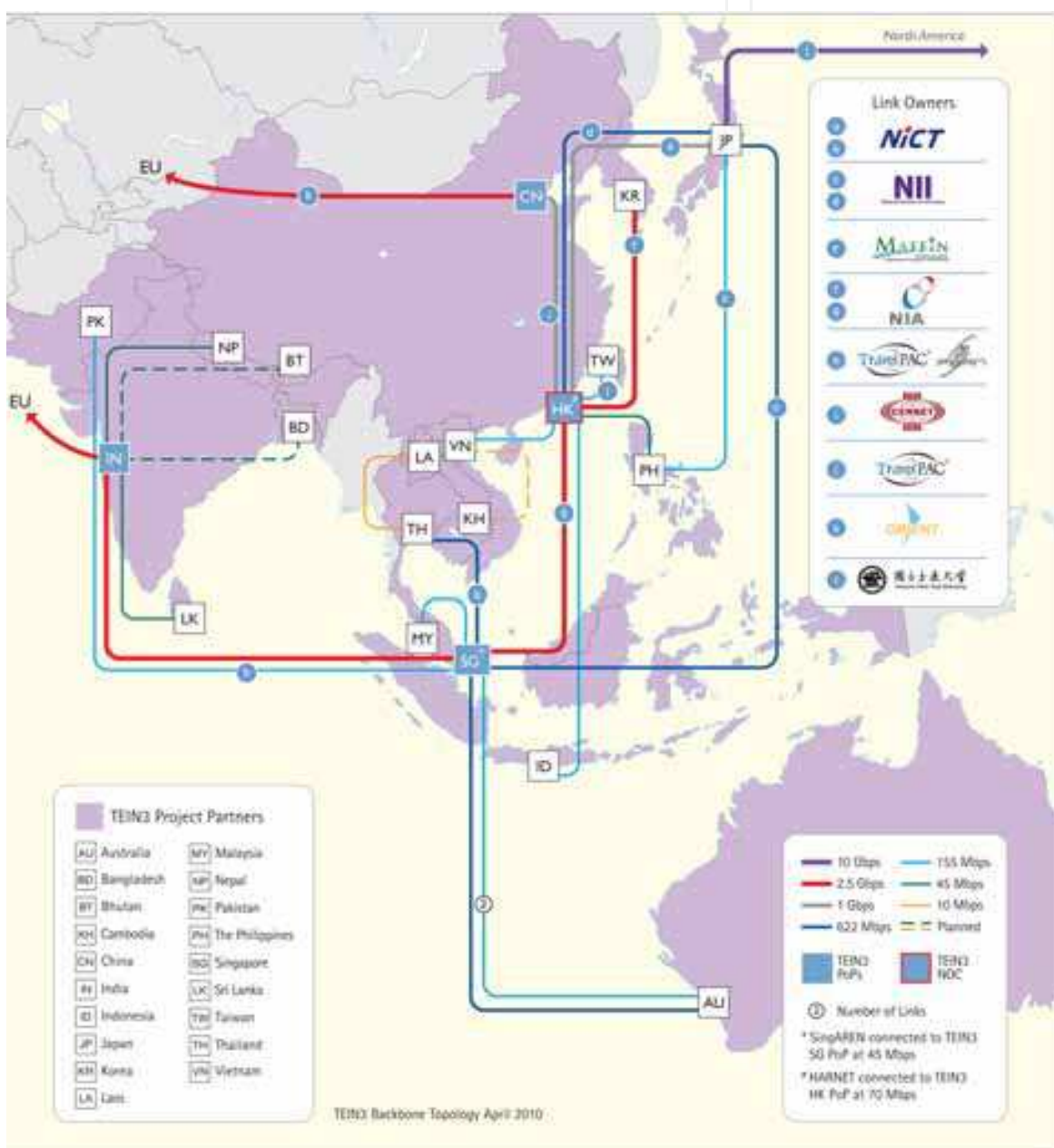

(http://www.tein3.net/upload/img/TEIN3_Topology_04.10_A4_300dpi.jpg)

Fig. 7. TEIN3 topology map

IntechOpen



IntechOpen

Fig. 8. Internet2 network topology (<http://www.internet2.edu/network/>)

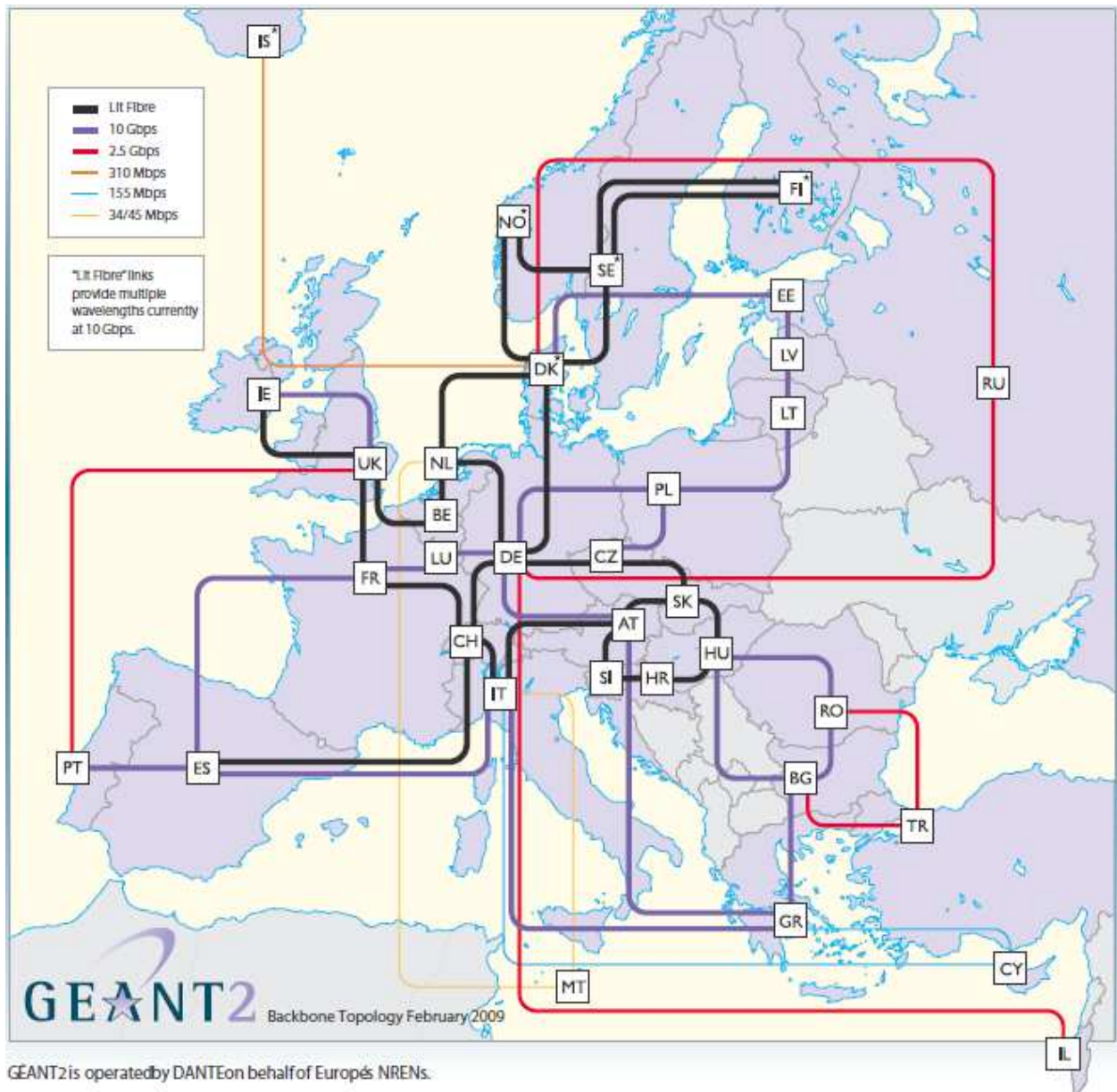
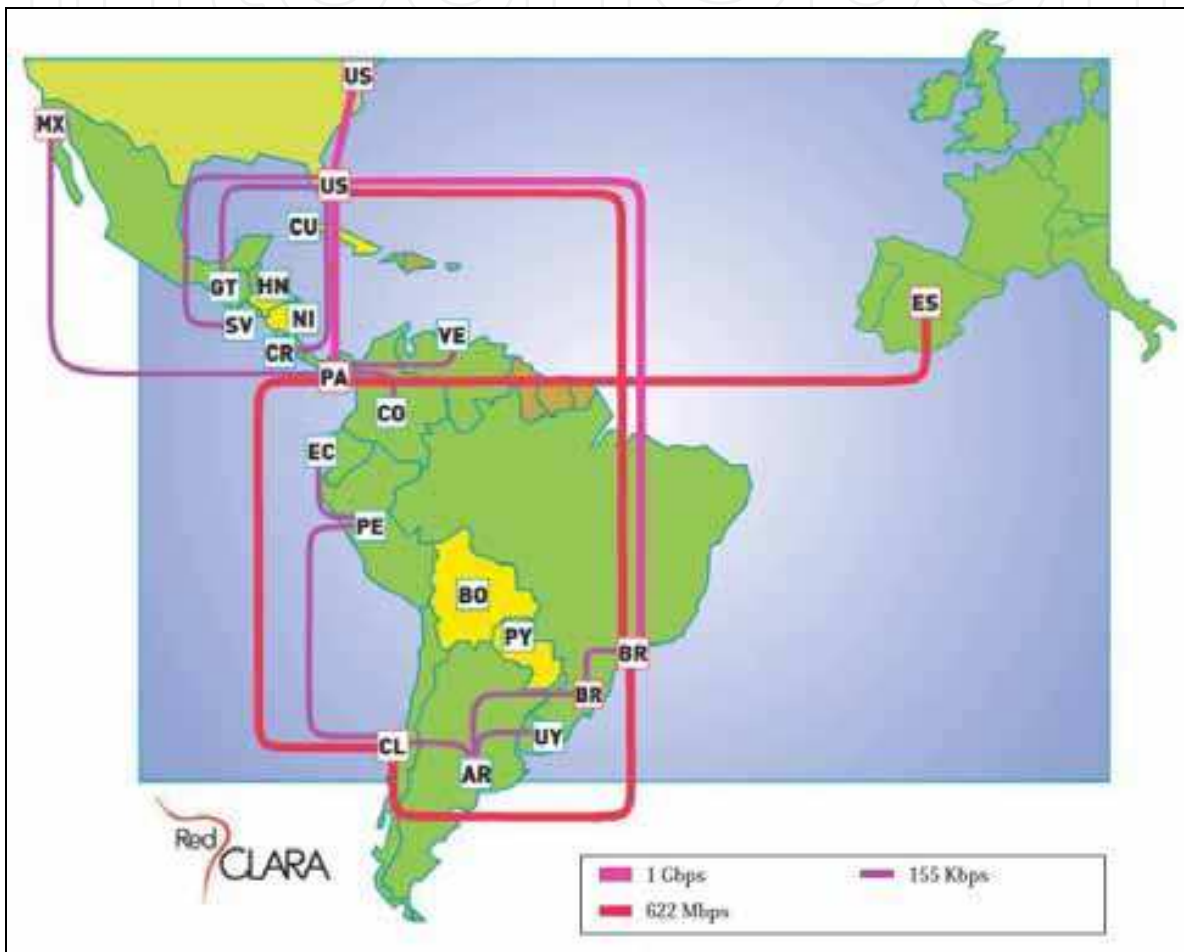

Fig. 9. GÉANT2 topology map

IntechOpen



(http://www.redclara.net/doc/topology_RedCLARA_March2010.pdf)

Fig. 10. RedCLARA topology map

3.2.6 Africa

The northern part of Africa is covered by the European R&E project, EUMEDCONNECT2 ([http:// www.eumedconnect2.net/](http://www.eumedconnect2.net/)). Egypt also has a direct connection with Internet2. On the other hand, South Africa has a collaboration with Europe at 155 Mbps. Countries with established NRENs include Egypt, Tunisia, Algeria, Morocco, Kenya, and South Africa. Actually, some cable systems have recently been established around Africa with huge bandwidth. Africa now has the chance to use such bandwidth (Fig. 11).

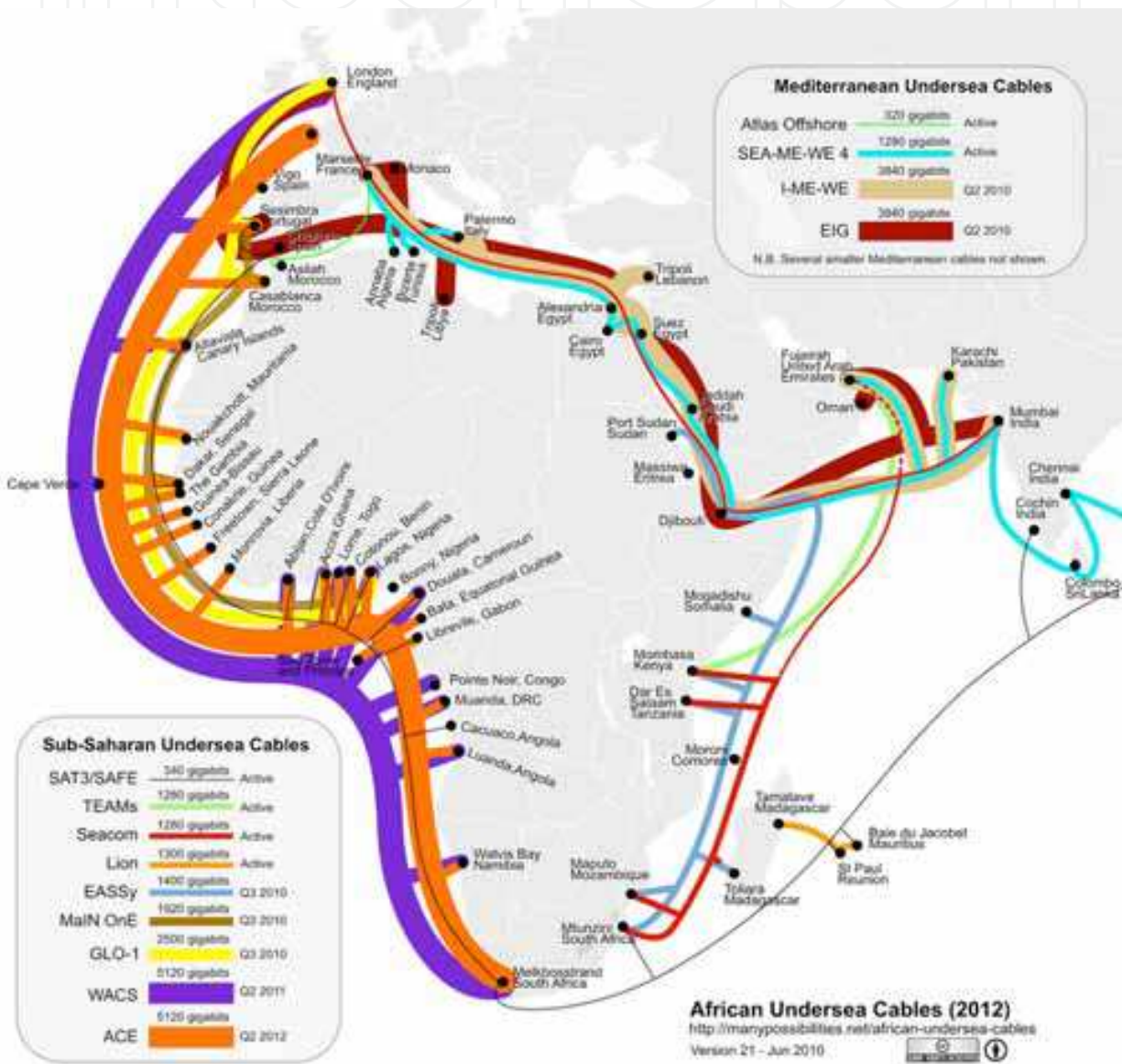

(<http://manypossibilities.net/african-undersea-cables/>)

Fig. 11. African undersea cable system map

3.3 How to check connectivity and create a new connection to a hospital

Each R&E network has its own management policies and these are not the same. But in general, universities and research institutions are connected with the R&E networks. Because of the campus management policies, however, all the departments in a university or research institution may not be able to use the R&E network. Thus, as a first step, please confirm whether your university or institution is listed as a member of the R&E network on the respective homepage, for example, APAN

(<http://www.apan.net/home/membership/members.php>) and Internet2

(<http://www.internet2.edu/membership/index.cfm>).

The tables should reflect the current situation, but some of the connection lists are not updated that frequently. You can, however, also check the connectivity yourself. "Traceroute" is a command in the BSD OS and its clones. Similar commands are available in other OSes as well. This command shows the route a communication takes. You should try to check the routes to some well-known universities (Fig. 12).

```
traceroute to www.internet2.edu (207.75.165.151), 30 hops max, 40 byte packets
 1 losa-tokyo-tp2.transpac2.net (192.203.116.145) 115.666 ms 115.674 ms 115.740 ms
 2 nlr-1-is-jmb-776.sttlwa.pacificwave.net (207.231.241.14) 143.236 ms 143.426 ms 142.948 ms
 3 denv-seat-58.layer3.nlr.net (216.24.186.6) 175.285 ms 171.899 ms 171.668 ms
 4 chic-denv-36.layer3.nlr.net (216.24.186.4) 197.273 ms 197.107 ms 196.841 ms
 5 tenge0-0-0-3x2087.nw-chil.mich.net (192.122.183.181) 185.242 ms 188.435 ms 185.270 ms
 6 tenge0-0-0-0x76.aa2.mich.net (198.108.23.10) 200.504 ms 200.453 ms 200.552 ms
 7 mam-77.merit.edu (192.122.200.77) 200.297 ms 200.299 ms 200.392 ms
 8 webprod0.internet2.edu (207.75.165.151) 200.260 ms !<10> 202.883 ms !<10> 201.300 ms !<10>
```

Fig. 12. Example of "traceroute" from APAN Tokyo XP to www.internet2.edu

If the names of the R&E networks are visible in the command output, these R&E networks are available at your site. If you cannot see any R&E network names, the R&E network services are probably not available at your site.

In this case, you need to establish a new connection to an access point of the R&E network. If you belong to a university or research institution, please take this issue up with the respective computer centre. The staff should know how to deal with this.

If your university or institution has a connection with the R&E network, you can discuss with the staff of the computer centre how to extend the connection to your own department or even your office. The IT staff will be able to advise you on the network configuration and network equipment required. If you cannot understand how to implement what the IT staff suggest, you should seek assistance from your colleagues who are more comfortable with IT concepts.

If your university or institution does not have a connection with an R&E network, it will be a little more complicated to set up, because most R&E networks require connections to be made at an institutional level.

Some of the R&E networks have a solution for this problem.

- Establishment of a temporary connection to the access points
- Establishment of a temporary connection to another institution as a sub-branch

Fig. 13 shows the process flow of the procedure discussed in this section.

4. Applications

We started this advanced telemedicine system as an activity in the Japan-Korea industry-government-academic joint project in 2003, with the aim of exchanging information in various fields such as education, business, culture as well as medicine over optic fiber

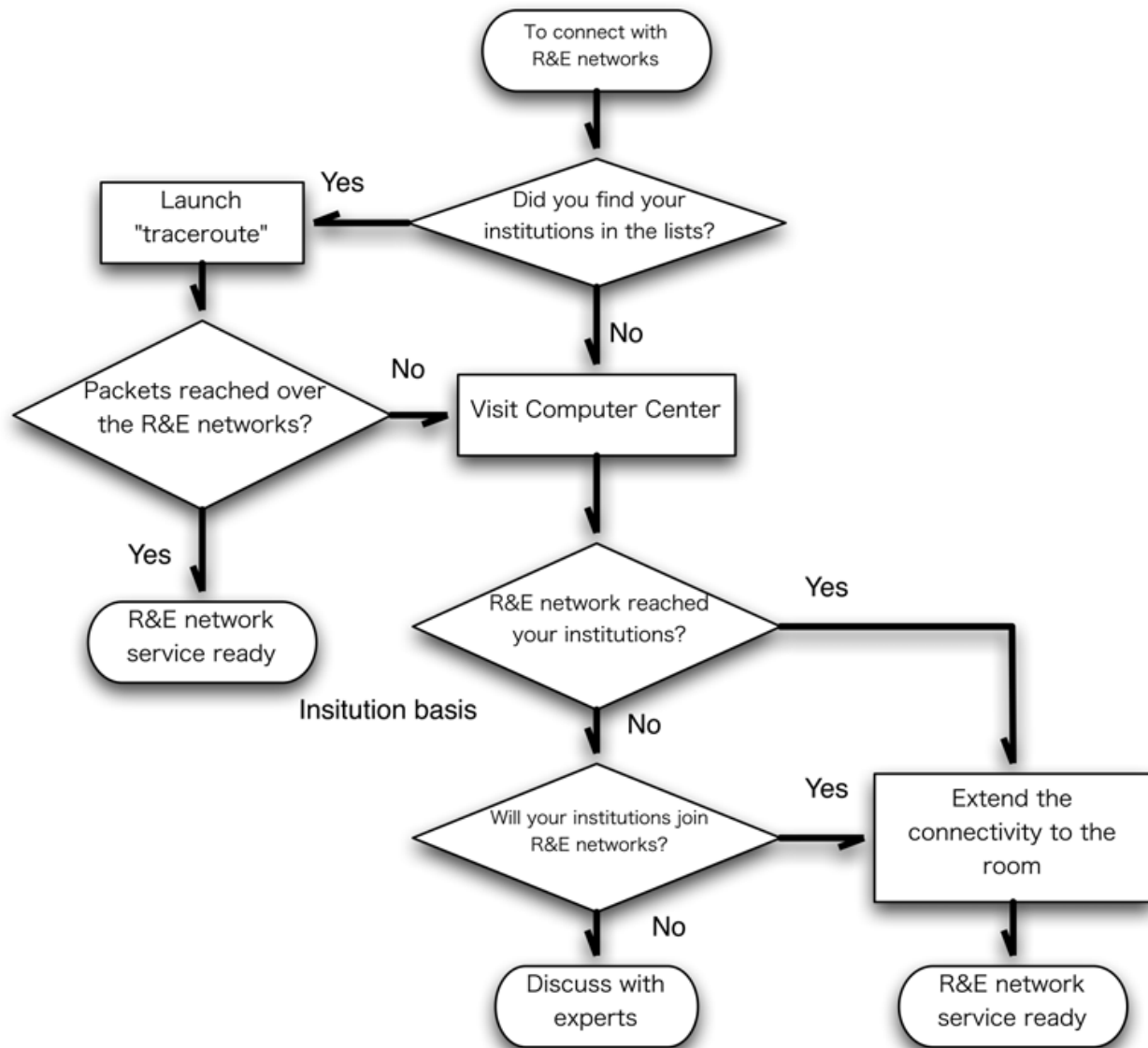

Fig. 13. Flowchart showing how to connect with an R&E network. Some R&E networks have help desks that can be contacted for assistance.

running under the strait between the two countries (Shimizu et al., 2006). This huge broadband cable, 250 times more than the conventional lines, was laid when the countries co-hosted the Soccer World Cup in 2002. We accumulated much experience and know-how from the first remote medical conference using DVTS. Moreover, because this system was found to be very useful and cost-effective, the activity was soon expanded outside the two countries, reaching China in Oct 2004, Southeast Asia in Jan 2005, Australia in Nov 2005, India and the USA in Jan 2007, and Europe in Aug 2007 (Carati et al., 2006; Huang et al., 2008; Shimizu et al., 2009). In May 2009, Egypt joined as the first country in Africa, with Brazil following suit in July 2009 as the first from South America.

Of the 223 telecommunications thus far, 78 were live demonstrations of surgery or endoscopy, for example, and 145 were teleconferences using video and slide presentations. In total, 726 universities and hospitals were connected. The details are given in Table 2 with some pictures of our recent events shown in Figures 14 and 15.

Contents	Country and region*																Total	
	JP	KR	CN	TW	TH	SG	PH	VN	ID	IN	MY	AU	NZ	EU	NA	SA		AF
Live demonstration																		
Surgery	61	39	19	4	4	7	4	1		4	1	6	2	4	2			158
Endoscopy	28	10	11	3	5	1		3			1	3		1				66
Hematology	5	3			1													9
Cardiac intervention	6	1	1															8
Others	2	1	1															4
Subtotal	102	54	32	7	10	8	4	4	0	4	2	9	2	5	2	0	0	245
Teleconference																		
Surgery	52	24	6	6	3	7	6	4			1	3		7	1		1	121
Endoscopy	76	23	14	13	11	5	1	2			3	3		6	9	2	2	170
Healthcare	17	7	2	1	3	1	1	1	2	2	1	3			7			48
Transplantation	16	6	4	3								1						30
Nursing	25		1					1	1									28
Medical informatics	6	7		1		1				2	3	1		2				23
Hepatobiliarypancreas	10	9		1														20
Others	20	5	2	3	3	2				1	1				4			41
Subtotal	222	81	29	28	20	16	8	8	3	5	6	13	1	13	23	2	3	481
Total connected stations	324	135	61	35	30	24	12	12	3	9	8	22	3	18	25	2	3	726

Table 2. List of activities and connected countries/ regions (as of June 2010). *KR, Korea; CN, China; TW, Taiwan; TH, Thailand; SG, Singapore; PH, the Philippines; VN, Vietnam; ID, Indonesia; IN, India; MY, Malaysia; AU, Australia; NZ, New Zealand; EU, European Union; NA, North America; SA, South America; AF, Africa

The most active countries/ regions are Japan and Korea, followed by China, Taiwan, Thailand, Singapore and Australia. These Asia-Pacific institutions often collaborate with their North American and European counterparts. The most common fields for live demonstrations are surgery and endoscopy, where clear moving images are of utmost importance for precise and adequate understanding. Quality evaluations have been reported by Eto et al. (2007) and Kaltenbach et al. (2009) in the fields of surgery and gastrointestinal endoscopy, respectively.

For the first couple of years, DVTS connections were possible only between two sites, or between several stations with multiple one-to-one connections. Since the emergence of Quatre as described in the previous section, however, real and practical multi-site connections have become possible and have rapidly increased in number. There has been a total of 92 two site and 131 multiple site connections, with the latter increasing to around 80% of the total connections in the last two years (Fig. 16). In these events, real-time discussions take place between all the connected stations, and interactive questions and answers are possible at multiple stations. The major collaborating societies include both national and international groups, such as the World Gastroenterology Organization (WGO), International Association of Surgeons, Gastroenterologists, and Oncologists (IASGO), Asia-Pacific Hepatobiliary Pancreatic Association (APHPBA), Endoscopic and Laparoscopic Surgeons of Asia (ELSA) 2006 & 2010, Korean Society of Gastroenterology, Thai Association of Gastroenterology, Japan Surgical Society 2009, and many others.



Fig. 14. Live demonstration of endoscopy at the Prince of Wales Hospital in the Chinese University of Hong Kong, connecting Xian and Shanghai in China, and Fukuoka, Japan.



Fig. 15. Live surgery transmitted from the Cancer Institute Hospital in Tokyo, Japan (top right), to Fukuoka/ Japan (top left), Shanghai/ China (bottom left), and Trondheim/ Norway (bottom right), with interactive discussions.

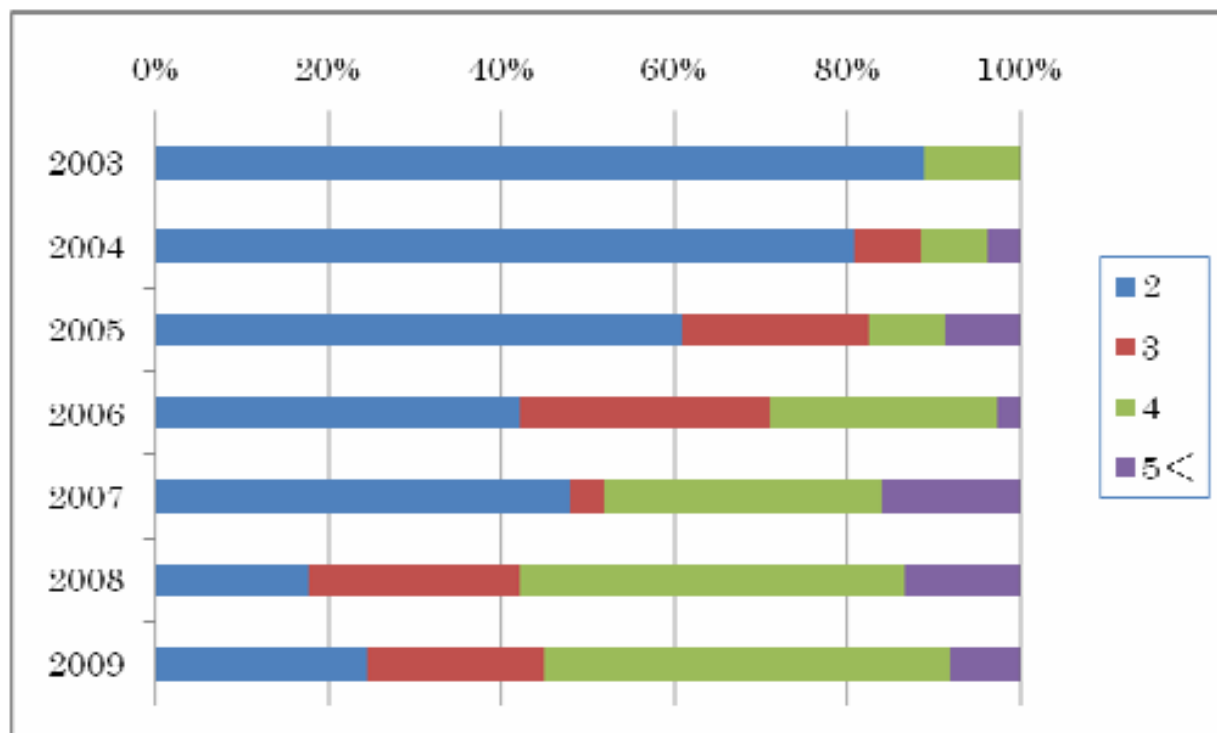

Fig. 16. Ratio of multiple connections

Currently, a main organizer of all these activities is the Medical Working Group in APAN, collaborating with other worldwide networks. The Telemedicine Development Center of Asia (TEMDEC), which was formally established at the Kyushu University Hospital, Japan, acts as the secretariat to lead the program preparations and technical arrangements. (<http://www.aqua.med.kyushu-u.ac.jp/>)

As of June 2010, the number of member institutions was 125 hospitals and institutions in 26 countries and regions, consisting of 31 in Japan, 19 in Korea, 10 in Australia, 9 in mainland China, and other major ones as shown in Table 3.

5. Discussion

5.1 Current problems

At the beginning of our telemedicine project, stable network conditions between remote stations were the most important concern for us. In fact, we had many experiences of teleconferences with image noise and jerky sound because of packet losses. Since then, network quality has improved very rapidly and widely, allowing stable connections to be established and many institutions to participate year after year. Nevertheless, there are still some issues that need to be solved and considered. The first is the limitation of Quatre, the only MCU currently available for DVTS. Although the participants find the multiple connections very attractive and more and more hospitals want to join the same conference, in practice, eight is the maximum number of stations that can be connected, because of the heavy load on the server. Another limitation of this MCU is that it is compatible only with NTSC video format which is mainly available in North America and East Asia and cannot be connected with PAL, which is popular in Southeast Asia and European countries. The availability of Quatre only in Japan also limits the multi-connections in other areas. The second issue is the fact that there are many hospitals that are not yet connected to the R&E

Country and region	Name of hospital or institution
Japan	Hokkaido University, Iwate Medical University, Tokyo Medical and Dental University, The Cancer Institute Hospital, Tokyo Science Foundation, Fujita Health University, Kyoto University, Kyoto Second Red Cross Hospital, Kobe University, Hiroshima University, Yamaguchi University, University of Occupational and Environmental Health, Kyushu University, Fukuoka University, Oita University, Saga University, Nagasaki University, Kyushu International College of Nursing, Fujimoto-Hayasuzu Hospital
Korea	Seoul National University, Bundang Hospital, Hanyang University, Ehwa Women's University, Yonsei University, Korea University, National Cancer Center, Asan Medical Center, Catholic University St. Mary's Hospital, Konkuk University, Chungnam University, Chungbuk University, Gyeongsang University
China	Tsinghua University, Peking University, Peking Union Medical College Hospital, Shanghai Jiaotong University Hospital, The Fourth Military University affiliated to Xijing Hospital, Chinese University of Hong Kong
Taiwan	National Taiwan University, Taipei Veteran General Hospital, Taichung Veteran General Hospital, National Central University
Thailand	Mahidol University Siriraj Hospital, Chulalongkorn University, Rajavithi Hospital, Pramongkutklao University Hospital
Singapore	National University of Singapore
Indonesia	University of Indonesia, Institute Technology of Bandung
Philippines	University of the Philippines, UP Manila General Hospital
Vietnam	National Hospital of Pediatrics, Backmai Hospital, No 108 Hospital, Choray Hospital
Malaysia	MYREN office
India	Tata Memorial Hospital
Australia	Flinders University, Australia National University, Concord Hospital, Royal Brisbane University Hospital
New Zealand	University of Auckland
USA	Stanford University, Florida International University, University of California Irvine, Seattle Science Foundation, University of Hawaii
Mexico	Universidad Nacional Autonoma de Mexico
Germany	University Hospital of Eppendorf in Hamburg
France	Bordeaux2 University
Italy	University of Rome3, Monaldi Hospital
Spain	Hospital Clinic I Provincial De Barcelona, University of Malaga
Norway	St Olavs University Hospital
Egypt	Cairo University, Theodor Bilharz Research Institute
Morocco	Mohamed V Souissi University
Brazil	University San Paolo Ribeirão Preto

Table 3. Major institutions linked by R&E networks using DVTS

network and have only a limited commercial network available, despite the fact that the R&E network is rapidly expanding in both bandwidth and location. These unconnected hospitals have to pay a network charge to the nearest point of the R&E network as previously described in Section 3. The third issue concerns the standardization and quality control of the local systems. The condition of intra-hospital networks and maintenance of audio-visual equipment should always be checked carefully by technicians in each institution.

5.2 New communication tools and demands for high-definition quality

With the rapid development of technology, there are other emerging options for remote communication other than DVTS. Skype is free software that is easily installed on a computer and widely used on a personal basis. However, Skype is mainly utilized for sound transmission instead of telephone and thus the image quality is far from perfect. Conventional H.323 videoconferencing systems like Polycom (Picturetel Corp. Danvers, MA) have also gained in popularity with their biggest advantage being the ease of handling and preparation. Furthermore, they provide all-in-one equipment, so there is no need to prepare microphones or cables to connect PCs. Nevertheless, once again the video image quality is only good enough for remote sites to recognize the person at the other end. The transmission of surgical videos would result in degraded and sluggish moving images without good recognition of fine anatomical structures, despite the initial high cost of the equipment (Shimizu et al., 2010).

Meanwhile, demands for even better quality video than that provided by DVTS are increasing rapidly, owing to high-definition (HD) quality medical equipment now being widely used in clinical settings. Although we succeeded in an international transmission of live surgery with uncompressed high-definition quality, we required extraordinarily expensive equipment with huge bandwidth such as 1.6 Gbps, which is more than 500 times larger than that necessary for DVTS (Shimizu et al., 2007). The transmission of compressed types of high-definition video may be an alternative, but the longer time delay would be detrimental to the comfortable interactive nature of the experience. In addition, the initial cost for the high-end equipment is prohibitive, which is exactly the same problem encountered with satellite connections. Although standard quality digital video (720 × 480 dpi) is gradually being replaced by HD quality (1920 × 1080 dpi) and the IEEE1394 interface by HDMI, DVTS will remain the best alternative in telemedicine until HD teleconferencing equipment becomes much more reasonably priced.

5.3 Tele-consultation

Because of the usefulness of high-quality video transmission in medicine, the system has been applied to various fields as listed in Table 2. Although current experience is not much, interventional cardiology looks promising and is expected to be one of the next major applications together with remote education for nurses and medical students. Disparity in medical services around the world is still very high, not only in terms of techniques and technology, but also in treatment strategies and ethical decisions. To standardize these issues, showing advanced operations and examinations using new medical equipment by means of live transmission, together with the possibility of interactive communication, seems to be very effective. This can provide a powerful, yet simple tool for learning advanced skills and new medical procedures across country borders. It is expected that telemedical education will be further developed in a variety of fields in the global range.

The applications mentioned above are all classified as remote education between healthcare providers. At present, tele-consultation is seriously being considered for use with this system as another target area where connections are made between doctors and patients (Kroenke et al., 2010; Mayes et al., 2010; Wei et al., 2008). Telemedical consultation, including diagnosis and second opinions, can provide expert opinions to remote general physicians, as well as support for the progressively aging society in the rural areas by the decreasing younger generation in the city. In addition, in cases of emerging infectious diseases, medical doctors in countries that have never been affected by the disease, can obtain “real” clinical experience and know-how for treating these diseases by viewing the treatment of remote patients in affected countries without the risk of getting infected. In order to make a tele-consultation as accurate as a face-to-face one and to implement tele-consultations in the social system, discussions involving government and healthcare organizations are truly necessary.

6. Conclusion

Considering all the aspects, we believe that DVTS is currently the best choice in terms of both quality and cost for telemedicine, where it is useful to explain various procedures by means of video and where image quality is a key factor. There is no doubt that DVTS has provided an efficient and practical communication means for exchanging medical knowledge and skills with medical-proof moving images on the R&E network and with minimal cost. However, medical personnel are not at all familiar with the two technologies, DVTS and the R&E network, and the initial setup of DVTS and handling of large networks is beyond their ability. Prevalence of these new technologies in the medical community and establishment of good cooperation between the two different groups of people, doctors and IT technicians, is essential to expand the telemedicine activity into daily practice, thereby finally providing better healthcare worldwide.

In the same way that our activity started when high-speed Internet was connected between Japan and Korea at the time of the Soccer World Cup in 2002, so too has South Africa, the World Cup host country in 2010, brought many new connections to Africa. The whole continent is now practically connected. We have organized a very active telemedicine society in the Asia-Pacific area under the leadership of the APAN Medical Working Group, and the establishment of two other key organizations, one in Europe/ Africa and the other in North/ South America, is now underway to coordinate global telemedicine.

7. Acknowledgement

The authors sincerely appreciate the commitment of the entire medical and technical staff of all the participating universities, institutions, and organizations and their kind cooperation and support, with special thanks to the APAN NOC team for their network expertise.

This project was funded in part by the Core University Program of the Japan Society for the Promotion of Science (JSPS) and the Korea Science and Engineering Foundation; the Asia Core Program of JSPS and the National Research Council of Thailand; the Japan-China Medical Exchange Program of JSPS and the China Academy of Medical Sciences; and Grant-in-Aid No. 20406027 from the JSPS.

8. References

- Anvari, M.; McKinley, C. & Stein, H. (2005). Establishment of the world's first telerobotic remote surgical service: for provision of advanced laparoscopic surgery in a rural community. *Ann Surg*, 241, 3, 460-4
- Augestad, K.M. & Lindsetmo, R.O. (2009). Overcoming distance: video-conferencing as a clinical and educational tool among surgeons. *World JSurg*, 33, 7, 1356-65
- Carati, C.; Shimizu, S.; Okamura, K.; Lomanto, D.; Tanaka, M. & Oouli, J (2006). High definition digital video links for surgical training. *JTelemed Telecare*, 12, S26-28
- Demartines, N.; Mutter, D.; Vix, M.; Leroy, J.; Glatz, D.; Rösel, F.; Harder, F. & Marescaux, J (2000). Assessment of telemedicine in surgical education and patient care. *Ann Surg*, 231, 2, 282-91
- Eto, M.; Lee, T.Y.; Gill, I.S.; Koga, H.; Tatsugami, K.; Shimizu, S.; Ukimura, O. & Naito, S. (2007). Broadcast of live endoscopic surgery from Korea to Japan using the digital video transport system. *JEndourol*, 21, 12, 1517-20
- Hazin, R. & Qaddoumi, I. (2010). Teleoncology: current and future applications for improving cancer care globally. *Lancet Oncol*, 11, 2, 204-10
- Hu, S.W.; Foong, H.B. & Elpern, D.J. (2009). Virtual Grand Rounds in Dermatology: an 8-year experience in web-based teledermatology. *Int J Dermatol*, 48, 12, 1313-9
- Huang, K.J.; Qiu, Z.J.; Fu, C.Y.; Shimizu, S. & Okamura, K. (2008). Uncompressed video image transmission of laparoscopic or endoscopic surgery for telemedicine. *Telemed e-Health*, 14, 5, 479-485
- Kaltenbach, T.; Muto, M.; Soetikno, R.; Dev, P.; Okamura, K.; Hahm, J & Shimizu, S. (2009). Teleteaching endoscopy: feasibility of real-time uncompressed video transmission by using advanced network technologies. *Gastrointest Endosc*, 70, 5, 1013-1017
- Kroenke, K.; Theobald, D.; Wu, J.; Norton, K.; Morrison, G.; Carpenter, J & Tu, W. (2010). Effect of telecare management on pain and depression in patients with cancer: a randomized trial. *JAMA*, 304, 2, 163-71
- Mayes, P.A.; Silvers, A. & Prendergast, J.J. (2010). New direction for enhancing quality in diabetes care: utilizing telecommunications and paraprofessional outreach workers backed by an expert medical team. *Telemed JE Health*, 16, 3, 358-63
- Ogawa, A.; Kobayashi, K.; Sugita, K.; Nakamura, O. & Murai, J. (1999). Design and implementation of dv stream over internet. *Proceedings of Internet Workshop IWS'99*, pp. 255-260, ISBN 0-7803-5925-9, Osaka, Japan, Feb 1999, IEE Publications, New York.
- Rabenstein, T.; Maiss, J; Naegele-Jackson, S.; Liebl, K.; Hengstenberg, T.; Radespiel-Tröger, M.; Holleczeck, P.; Hahn, EG. & Sackmann, M. (2002). Tele-endoscopy: influence of data compression, bandwidth and simulated impairments on the usability of real-time digital video endoscopy transmissions for medical diagnoses. *Endoscopy*, 234, 9, 703-10
- Shimizu, S.; Nakashima, N.; Okamura, K.; Hahm, JS.; Kim, Y.W.; Moon, B.I.; Han, H.S. & Tanaka, M. (2006). International transmission of uncompressed endoscopic surgery images via super-fast broadband internet connections. *Surg Endosc*, 20, 1, 167-170
- Shimizu, S.; Han, H.S.; Okamura, K.; Yamaguchi, K. & Tanaka, M. (2007). Live demonstration of surgery across international borders with uncompressed high-definition quality. *HPB (Oxford)*, 9, 5, 398-399

- Shimizu, S.; Nakashima, N.; Okamura, K. & Tanaka, M. (2009). One hundred case studies of Asia-Pacific telemedicine using digital video transport system over research and education network. *Telemedicine JE Health*, 15, 1, 112-117
- Shimizu, S.; Han, H.S.; Okamura, K.; Nakashima, N.; Kitamura, Y. & Tanaka, M. (2010). Technologic developments in telemedicine: State-of-the-art academic interactions. *Surgery*, 147, 5, 597-601
- Wei, Z.; Wu, Y.; Deng, R.H.; Yu, S.; Yao, H.; Zhao, Z.; Ngoh, L.H.; Han, L.T. & Poh, E.W. (2008). A secure and synthesis tele-ophthalmology system. *Telemed JE Health*, 14, 8, 833-45

IntechOpen

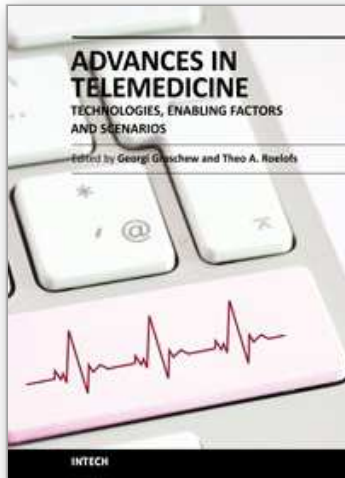

Advances in Telemedicine: Technologies, Enabling Factors and Scenarios

Edited by Prof. Georgi Graschew

ISBN 978-953-307-159-6

Hard cover, 412 pages

Publisher InTech

Published online 16, March, 2011

Published in print edition March, 2011

Innovative developments in information and communication technologies (ICT) irrevocably change our lives and enable new possibilities for society. Telemedicine, which can be defined as novel ICT-enabled medical services that help to overcome classical barriers in space and time, definitely profits from this trend. Through Telemedicine patients can access medical expertise that may not be available at the patient's site. Telemedicine services can range from simply sending a fax message to a colleague to the use of broadband networks with multimodal video- and data streaming for second opinioning as well as medical telepresence. Telemedicine is more and more evolving into a multidisciplinary approach. This book project "Advances in Telemedicine" has been conceived to reflect this broad view and therefore has been split into two volumes, each covering specific themes: Volume 1: Technologies, Enabling Factors and Scenarios; Volume 2: Applications in Various Medical Disciplines and Geographical Regions. The current Volume 1 is structured into the following thematic sections: Fundamental Technologies; Applied Technologies; Enabling Factors; Scenarios.

How to reference

In order to correctly reference this scholarly work, feel free to copy and paste the following:

Shuji Shimizu, Koji Okamura, Naoki Nakashima, Yasuichi Kitamura, Nobuhiro Torata, Yasuaki Antoku, Takanori Yamashita, Toshitaka Yamanokuchi, Shinya Kuwahara and Masao Tanaka (2011). High-Quality Telemedicine Using Digital Video Transport System over Global Research and Education Network, *Advances in Telemedicine: Technologies, Enabling Factors and Scenarios*, Prof. Georgi Graschew (Ed.), ISBN: 978-953-307-159-6, InTech, Available from: <http://www.intechopen.com/books/advances-in-telemedicine-technologies-enabling-factors-and-scenarios/high-quality-telemedicine-using-digital-video-transport-system-over-global-research-and-education-ne>

INTECH
open science | open minds

InTech Europe

University Campus STeP Ri
Slavka Krautzeka 83/A
51000 Rijeka, Croatia
Phone: +385 (51) 770 447
Fax: +385 (51) 686 166

InTech China

Unit 405, Office Block, Hotel Equatorial Shanghai
No.65, Yan An Road (West), Shanghai, 200040, China
中国上海市延安西路65号上海国际贵都大饭店办公楼405单元
Phone: +86-21-62489820
Fax: +86-21-62489821

www.intechopen.com

www.intechopen.com

IntechOpen

IntechOpen

© 2011 The Author(s). Licensee IntechOpen. This chapter is distributed under the terms of the [Creative Commons Attribution-NonCommercial-ShareAlike-3.0 License](#), which permits use, distribution and reproduction for non-commercial purposes, provided the original is properly cited and derivative works building on this content are distributed under the same license.

IntechOpen

IntechOpen