

# We are IntechOpen, the world's leading publisher of Open Access books Built by scientists, for scientists

4,800

Open access books available

122,000

International authors and editors

135M

Downloads

Our authors are among the

154

Countries delivered to

TOP 1%

most cited scientists

12.2%

Contributors from top 500 universities



WEB OF SCIENCE™

Selection of our books indexed in the Book Citation Index  
in Web of Science™ Core Collection (BKCI)

Interested in publishing with us?  
Contact [book.department@intechopen.com](mailto:book.department@intechopen.com)

Numbers displayed above are based on latest data collected.

For more information visit [www.intechopen.com](http://www.intechopen.com)



# An Evidence Accrual Data Fusion Technique for Situational Assessment

Stephen C. Stubberud<sup>1</sup> and Kathleen A. Kramer<sup>2</sup>

<sup>1</sup>*Oakridge Technology*

<sup>2</sup>*University of San Diego*  
USA

## 1. Introduction

Systems have become significantly more complex as more sensors, actuators, and processing can all be contained within a single system. Such systems now process ever increasing amounts of data that can be used to better understand the environment and issues that concern the system. Whether the system is autonomous or involves an operator in the decision loop, processing the data into useful information is of paramount importance. The process of combining this data into a clearer picture is often referred to as data fusion.

These systems are more complex than have been developed in the past. This includes an increase in the number of sensors that monitor not only the external environment of the system but also the current operational state of the system. Systems such as unmanned aerial vehicles (UAVs) and robots may operate according to a set script of actions or be tele-operated but still must have a set of autonomous capabilities to overcome changes in operational conditions, avoid obstacles and other hazards, and be able to identify potential threats or mission criteria.

Often, a single sensor cannot provide all the information that necessary to recognize the issue, event, or target of interest. With multiple sensors, more data is available, but the resulting streams of measurement data produced create a number of issues. The concept of data fusion is applied in these cases to sift through the often voluminous amounts of data, determine which data is important, associate the important data that is related, and combine the data into information that provides an improved understanding of internal or external environment.

Data fusion is the ability to combine information from various sources, e.g., sensor systems, databases, individual perspectives, etc., into a coherent picture that improves the overall understanding of the events of interest. In some cases, such as target tracking or image understanding, specific types of algorithms can be used to fuse the data into a clearer picture. Data in those cases are often of a similar format and can be easily combined. For other problems, such as classification of entities or events, situation assessment, or impact assessment, the data come from a variety of nonrelated sources. In this chapter, a situation assessment data fusion technique for mechatronic systems is developed where the development of relationships of events or objects are determined. The examples that will be addressed with this type of fusion include a condition-based monitoring system

(Brotherton et al., 2002) that looks to relate various reports such as engine temperature and fluid pressures to determine if a correlation between events exists and the tracking of targets to determine if the targets are operating together.

Evidence accrual is one approach to fuse the data for situational assessment. Often, evidence accrual approaches are based on Bayesian taxonomies or networks that attempt to directly relate the probabilities involved. While the underlying probabilistic principles are well understood, implementations frequently use heuristics to overcome some of the practical difficulties, such as uncertainties and the injection of a probability of zero. An alternative approach is an evidence accrual algorithm that uses dynamic systems modeling and a fuzzy Kalman filter (FKF) to propagate information and to incorporate new evidence. The technique has the advantage over typical approaches in that it can provide an uncertainty or quality measure with the results estimate. The technique of the FKF allows for the use of observation or measurement uncertainty to be incorporated into the injection value and produced a level-of-evidence state estimate with an associated uncertainty.

These observations can be direct observations in that they measured the estimated state directly. For example, a pressure sensor can measure the oil pressure in an engine. With a more complex system, however, observations are often indirect. Temperature sensors, pressure sensors, and acoustic sensors can be used to estimate an oil leak and an imminent engine seizure. Also, the observations or measurements may provide only a partial description, such as a bearings-only measurement provides to a target track, or might need to be combined with other measurements to provide a full description of a state element, such as positions over time are used to provide velocity estimates.

In this chapter, this evidence accrual technique is developed and then applied to two systems. The first is an automated situation assessment operation where observations of various objects in the region of interest (ROI) are processed to determine which have the potential to be operating together. The second example looks at the health monitoring capabilities of an autonomous vehicle. The development begins with a detailed summary of data fusion. This is followed by an overview of linear systems theory and the fuzzy Kalman filter. These component technologies are then combined into the evidence accrual system.

## **2. Situational assessment as a level of data fusion**

The Joint Directors Laboratory (JDL) fusion model (Steinberg et al., 1999) decomposes the fusion problem into five subcategories, Level 0 to Level 4. These levels of fusion begin with lowest level, Level 0, that deals with the processing necessary to make measurements from the signals that sensors collect. Level 1 defines the state of the object or event. Levels 2 and 3 are much more complex concepts that build relationships between objects and their impact on other events or objects. Finally, Level 4 is refinement. This the process to reconfigure sensor systems or adapt algorithms to improve performance. As seen in Figure 1, the various levels of fusions not only build on each other but also interact. In this development, Level 1 and Level 2 fusion are the two components that are considered.

In Level 1, the objects are considered targets that are being tracked or classified, obstacles that are detected, events that are identified (such as turbulence or an abrupt change in target behavior), and changes in performance that may indicate a fault or failure in the systems capabilities. These objects are the measurements and the elements that are used to create the Level 2 state.

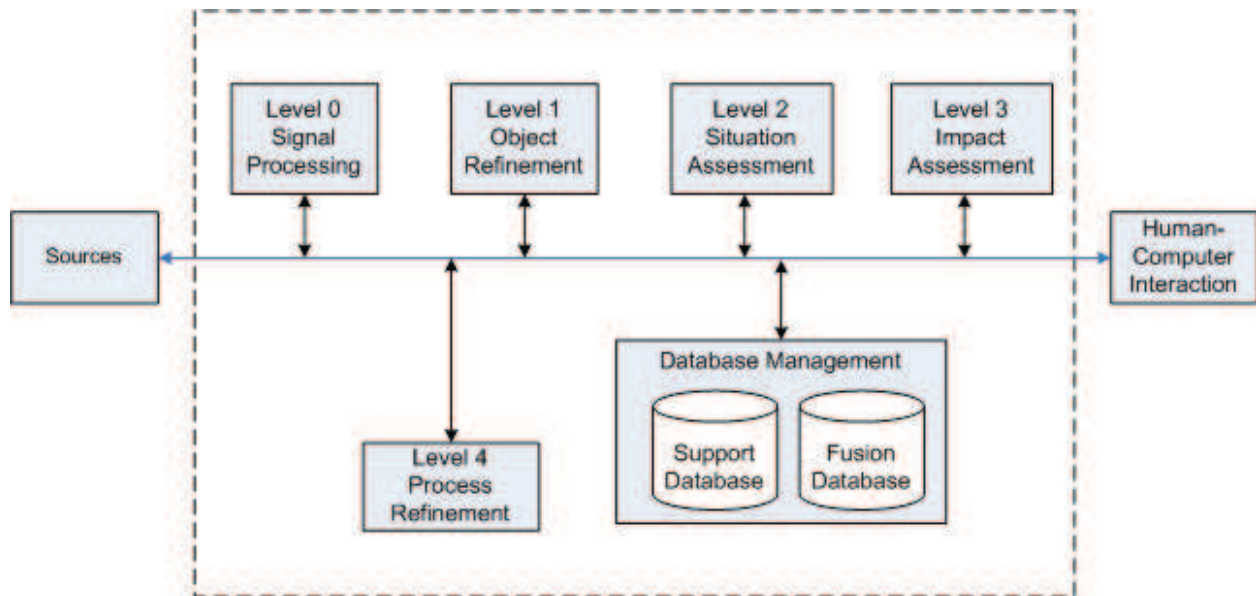

Fig. 1. Situation Assessment, or Level 2 fusion, is a component of the overall data fusion problem.

Level 2 fusion is referred to as Situation Assessment. While there is a significant amount of debate on the definition of Situation Assessment (Hall & Llinas, 2001), for this chapter, Level 2 fusion refers to the development and interpretation of relationships between entities or Level 1 objects. Many approaches have been developed to handle the Level 2 fusion problem. One approach to the Level 2 problem (Stubberud et al., 2003a; Llinas et al., 2004) is an extension of the Bowman model that was developed for Level 1 Fusion. While to some this model implies a Kalman filter implementation, the functional flow can be easily expanded beyond that simplistic viewpoint. As seen in Figure 2, the functional flow of the Level 2 problem is decomposed into a set of functional subcomponents. In this effort, the concentration is on the association component. Unlike Level 1 association that compares measurements to existing tracks as discussed in (Steinberg et al., 1999), Level 2 association must also incorporate interpretation of the relationships.

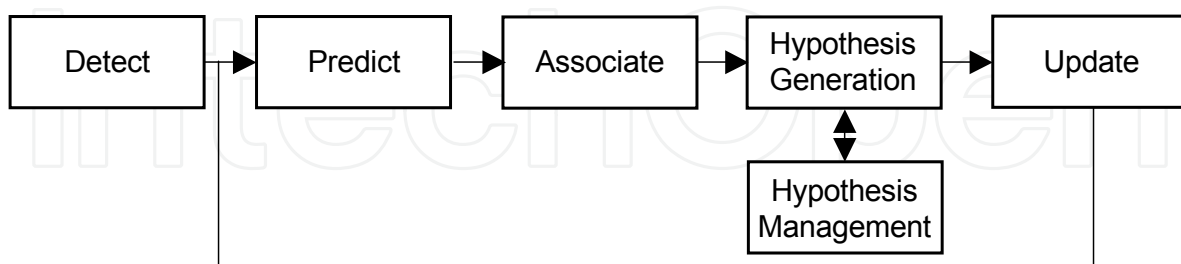

Fig. 2. Level 2 fusion architecture.

The first step to create the relationships is to develop a representation for a Level 2 object. The chosen representation is a state vector that can be comprised of information in a variety of formats, including numeric and linguistic reports. Each state component can be processed using different techniques. For the extension of target tracking, the Level 2 state can be defined as the elements that would define a relationship between targets. No matter the representations or information chosen for a Level 2 object, each subcomponent of the state

must have a measure or metric associated with it to develop data association scores with other detected objects and measurements. The basic state structure of a coordinated group would be given as

$$[a \ b \ c \ d]^T \quad (1)$$

where

$$a = \begin{bmatrix} x_{unit} \\ y_{unit} \\ x'_{unit} \\ y'_{unit} \end{bmatrix}, \quad b = \begin{bmatrix} \#ofclass_1^1 \\ \vdots \\ \#ofclass_1^m \\ \vdots \\ \#ofclass_n^1 \\ \vdots \\ \#ofclass_n^m \end{bmatrix}, \quad (2)$$

$$c = \begin{bmatrix} formation \\ formation\ change \end{bmatrix}, \quad \text{and} \quad d = \begin{bmatrix} group\ extent1 \\ group\ extent2 \end{bmatrix}$$

This state representation of this group contains four pieces of group information: kinematic, composition, formation, and extent. The extent component represents the physical footprint of the group along with a range of influence which may be the range of weaponry, communications, or the influence of command. In (Stubberud et al., 2003b; Stubberud & Shea, 2003), association metrics were developed for each component of the state vector defined in Eqs. (1) and (2). The state vector provides a group representation based on Level 1 information developed for individual targets such as classification and kinematic states. Using other knowledge such as doctrine and inferences such as road structure, the Level 1 objects are combined into Level 2 objects.

Most Level 2 fusion techniques have been developed combine various data including numeric, inference, linguistic, heuristic, and fuzzy (Hall & Llinas, 2001; Chen, 1996). While each of these techniques has been shown to work well as defined, most implementations were developed without consideration of the uncertainty associated with the measurements that created or are fused into them. More effective fusion would provide for means of uncertainty or error estimates in the information provided by the Level 1 object states to influence the determination of the relationship between objects. Poor kinematic estimates as opposed to those with a better pedigree should be weighted less.

The Level 2 fusion approach developed in this chapter is designed to incorporate the uncertainty of the information as well as in the understanding of the process used to fuse the information.

### 3. Evidence accrual for situation assessment

Evidence accrual is a technique that has been applied often to the Level 2 fusion problem, as in (Buczak & Uhrig, 1995; Hammell & Sudkamp, 1998; Le Hegarat-Masclé, 1997; Stubberud & Kramer, 2007, 2008). The section begins with a discussion of two standard techniques that have been used in the evidence accrual application, Bayesian Taxonomy and Dempster-

Shafer. A newer technique, referred to as Feature Object Exploitation (FOX), can incorporate uncertainty measures and is based on a combination of linear systems theory, fuzzy logic, and Kalman filtering is then developed. The development of the evidence accrual architecture for the FOX approach shows that the data injection is provided by the FKF. The propagation of the data through the architecture is generated using linear systems theory. The FOX approach provides for a variety of input formats, can utilize partial information observations, and can incorporate an uncertainty measure into each state estimate.

### 3.1 Bayesian taxonomy and Dempster Shafer

Bayesian taxonomy (Pearl, 1988) and the Dempster-Schafer method (Dempster, 1967; Shafer, 1976) are the two classification techniques that are considered standards in the Level 1 fusion community (Blackman & Popoli, 1999).

#### 3.1.1 Bayesian taxonomy

The Bayesian taxonomy is theoretically straightforward in its implementation with the propagation of probabilities from an injection of new information throughout the tree-like structure, as shown in Figures 2a and 2b. The purpose of the Bayesian classification tree is to provide a probability belief in the classification of a target. The architecture selected to create the Bayesian classification tree is the taxonomic hierarchy, also known as a Pearl tree. The Pearl tree is an  $n$ -node (as opposed to binary) tree structure whose nodes represent exhaustive and mutually exclusive hypotheses. Each such node is initially assigned an a priori probability, also known as a measure of belief or a score, reflecting the prior probability that the hypothesis is true given all previous evidence. These measures of belief range from 0, indicating no confidence, to 1, indicating complete confidence. The probability at the root node of the tree is always 1, while the measure of belief at each intermediate node is the sum of the scores of its immediate children.

Figure 2a illustrates a simple Pearl tree for target classification. In this example, the numbers included with the node names represent the measures of belief. Clearly, the previous evidence suggests that the target is a hostile aircraft. New evidence can be “injected” into one or more nodes. This evidence takes the form of likelihood ratios, where confirming evidence is greater than 1 and non-confirming evidence is less than 1. The impact of the evidence on each node in the hierarchy is calculated by applying propagation-based updating rules that specify messages to be passed between nodes. Information propagates up and down the tree in such a way that “cutting” across the tree in any way results in a sum of one. For example, confirming evidence with a likelihood of 1.9 is injected into the tree presented in Figure 2a at node “Air Superiority Fighter”.

$BEL(S)$ , the probability or belief at that node  $S$ , is updated via

$$BEL^+(S) = \alpha_S \lambda_S BEL(S), \text{ where } \lambda_S \text{ is the likelihood ratio and } \alpha_S = \frac{1}{1 - (1 - \lambda_S) BEL(S)}.$$

This value is then propagated up and down the tree using Bayesian conditional probabilities. The result of applying the propagation-based updating rules would yield the revised tree shown in Figure 2b. In this example, the injection of the confirming evidence at node “Air Superiority Fighter” caused the shaded nodes’ probabilities to increase. The probabilities for all other nodes, with the exception of the never-changing root node, decreased as a result of this confirming evidence.

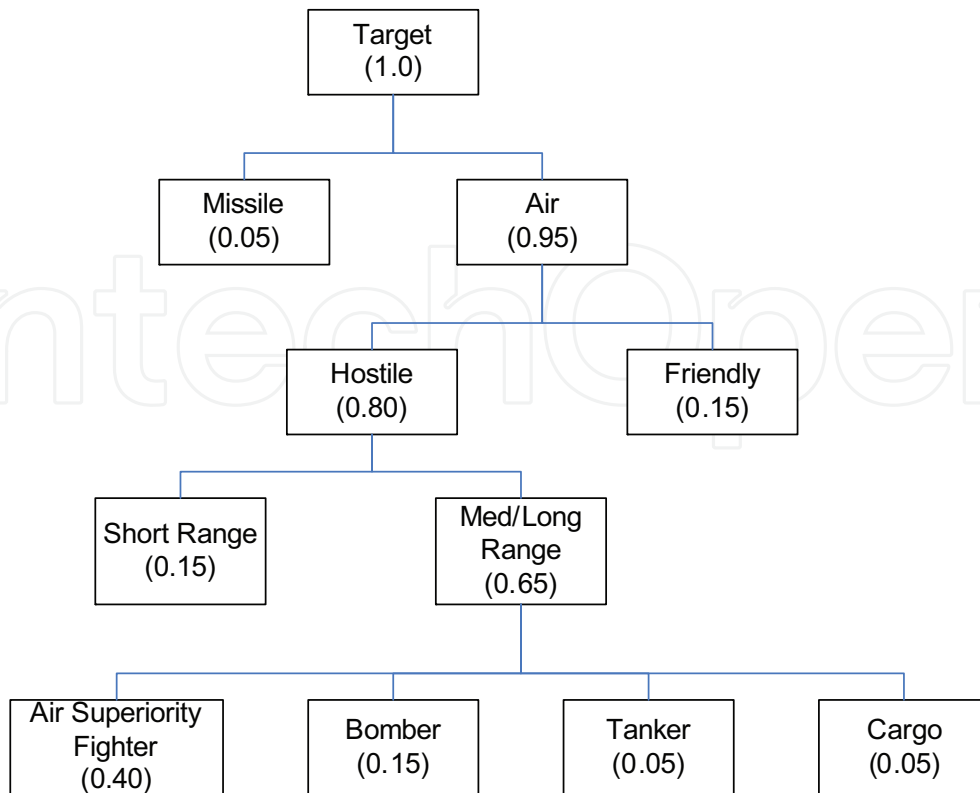

Fig. 2a. Bayesian Network with *A Priori* Probabilities

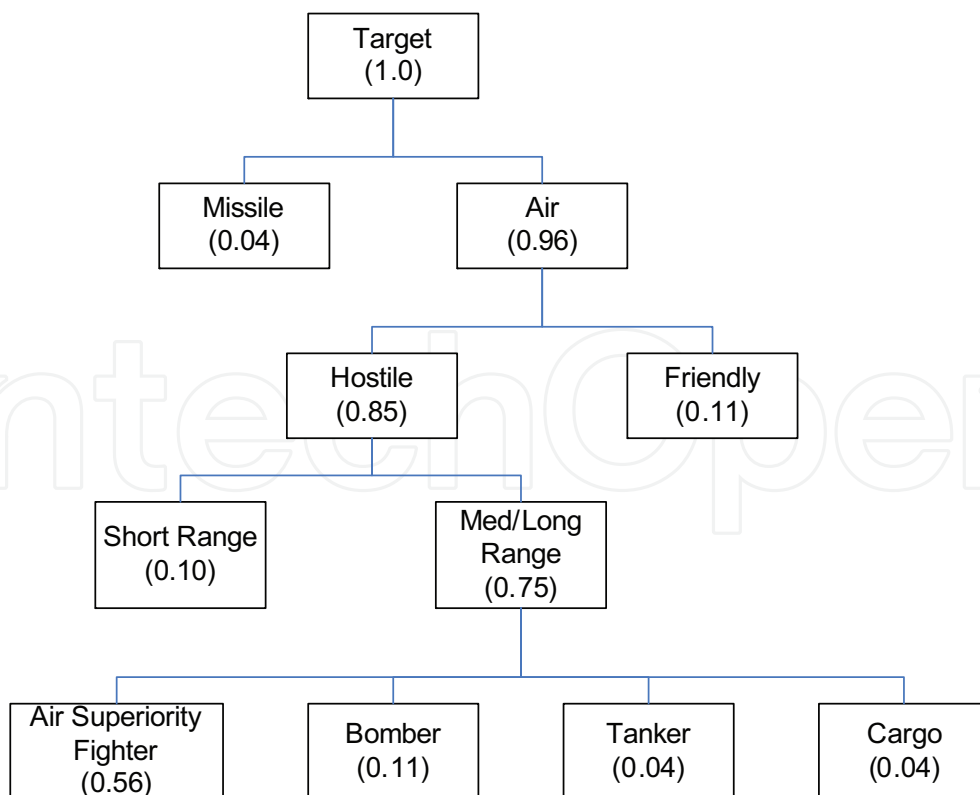

Fig. 2b. Bayesian Network after Processing Confirming Evidence of Type "Air Superiority Fighter".

### 3.1.2 Dempster-Schafer

The Dempster-Schafer method is a generalized Bayesian inference which can incorporate uncertainty. It is a more complex approach that can incorporate both uncertainty and lack of information into its model. The result provides not only a probability of a given solution, but also a measure of its plausibility. Often, this technique is referred to in the literature as an evidential approach. When the information (input from sensors, sources, and the models used) is independent, the approach is a powerful tool in providing accurate solutions.

Unlike the Bayesian taxonomy, each sensor is allowed to contribute information based on its own capabilities. Assume a set of target types  $\{t_1, t_2, \dots, t_n\}$  that are mutually exclusive and exhaustive. A probability mass is assigned to any element of the set and any possible disjunction, where a disjunction is the event of a subset based on an OR operation. So a disjunction can be the event that Target 1 or Target 2 occurs. Negation indicates the opposite of a proposition. The sum of the probability mass of all propositions, disjunctions, and negations that are defined is equal to 1. The representation of the uncertainty is given as the disjunction of all of the original propositions,  $\theta$ .

In one example  $t_1$  is defined as a hostile missile,  $t_2$  a neutral launch, and  $t_3$  a friendly missile. A report of an unannounced launch is provided. The mass assignment is given as

$$\mathbf{m}_1 = \begin{bmatrix} m(\theta) = 0.02 \\ m(t_1, t_2) = 0.98 \end{bmatrix}$$

The probability that all three missile types could have occurred is thus 2% and the probability that it is a hostile or neutral is 0.98. The uncertainty in this case is quite small.

A second sensor in this example determines classification based on the plume of the missile. The mass assignment for this sensor is given as

$$\mathbf{m}_2 = \begin{bmatrix} m(\theta) = 0.2 \\ m(t_2, t_3) = 0.4 \\ m(t_1) = 0.4 \end{bmatrix}$$

Using information from both sensors, the classification becomes

$$\begin{aligned} m(\theta) &= m_1(\theta) \cdot m_2(\theta) = 0.004 \\ m(t_1) &= m_1(\theta) \cdot m_2(t_1) + m_1(t_1, t_2) \cdot m_2(t_1) = 0.008 + 0.392 = 0.4 \\ m(t_2) &= m_1(t_1, t_2) \cdot m_2(t_2, t_3) = 0.392 \\ m(t_1, t_2) &= m_1(t_1, t_2) \cdot m_2(\theta) = 0.196 \\ m(t_2, t_3) &= m_1(\theta) \cdot m_2(t_2, t_3) = 0.008 \end{aligned}$$

Inconsistencies between reports can be incorporated when using Dempster-Schafer by increasing the uncertainty. This is done by summing the multiplications of all inconsistencies. For example, this would be a sensor  $m_3$  that only classifies each individual target. Thus, when fused with Sensor 1, the inconsistency of  $m(t_2)$  and  $m(t_1, t_3)$  would be computed. This value is then subtracted from 1. The resulting value then divides the other values.



### 3.1.3 Drawbacks of probabilistic classification algorithms

Both of these probabilistic techniques have drawbacks to their applications. First, when the measurements are not independent, information is repeatedly injected into the system, thus skewing the results. This condition is often a result of improper modeling of sensors or the sensors' relationships to one another. With a Bayesian taxonomy, a concern arises when the probabilistic models of the sensor reports to the potential class are not properly defined or are not consistent across sensors. For example, a given classifier may be developed on the premise that the probability of a class is based on the number of vehicles of each class that would be seen for a given event. With other sensors using the same approach, multiple classes that all have similar characteristics but different weighted probabilities could be adversely affected when the information is combined. Usually, this results from the misunderstanding of the probabilities or from the fact that the models for different sensors are developed by different individuals with different viewpoints of the problem.

Another concern is that the inputs of these probabilistic techniques require numeric information. If the information is symbolic or linguistic, it must be mapped into numeric information in the form of a crisp value with a possible associated uncertainty measure. The Bayesian taxonomy technique has difficulty in incorporating uncertainty about measurements or the quality of the information sources. The solution is to either to spend the time to properly model the various uncertainty conditions into the underlying probability density functions or to use ad hoc methods. The modeling of the uncertainty can be quite complex as environmental and sensor nuances are not always readily understood in a sensor's deployment. When ad hoc techniques are used to correct this problem, the underlying probability foundation is lost. Both the Bayesian taxonomy and the Dempster-Schafer method have the problem that they are confined to the axioms of probability, requiring that the evidence does couple across classes when normalization takes place. Even with Dempster-Schafer, the effects of evidence that only pertains to one class will have an indirect effect on all of the others.

Finally, in both techniques, the formal application of the techniques is computationally complex. The Dempster-Schafer method, in particular, is also known to be computationally intensive and, for large number of classes, the method is avoided.

To overcome these drawbacks, a fuzzy logic approach is developed. According to (Kosko, 1992) and (Watkins, 1994), fuzzy logic can be considered a super set of Bayesian probability. Based on the Bayesian similarities of fuzzy logic developed in (Watkins, 1994), a fuzzy approach to Level 2 fusion based on well known techniques such as Kalman filtering and systems theory is developed.

## 4. Evidence accrual architecture

To develop the evidence accrual algorithm, a tree structure similar to that of the Bayesian taxonomy (see Figure 3) is developed. Each node is a Level 2 object or an important element of the development of a Level 2 object. The links between nodes represent the functional relationships between the various Level 2 objects and elements. The top node is the highest Level 2 object of interest.

The tree structure allows for a decomposition of the fusion problem into smaller sub-problems that are less complex to develop than creating a single Level 2 object from all of the inputs and databases. The measurements are injected at the different levels using a fuzzy Kalman filter. The FKF provides an ability to incorporate numeric and nonnumeric data as

measurements. It also allows for the incorporation of uncertainty measures into the state vector. The data is propagated up the tree structure using systems theory. This provides for both state propagation and uncertainty propagation. Linear, nonlinear, and fuzzy system approaches are all able to be used along the links.

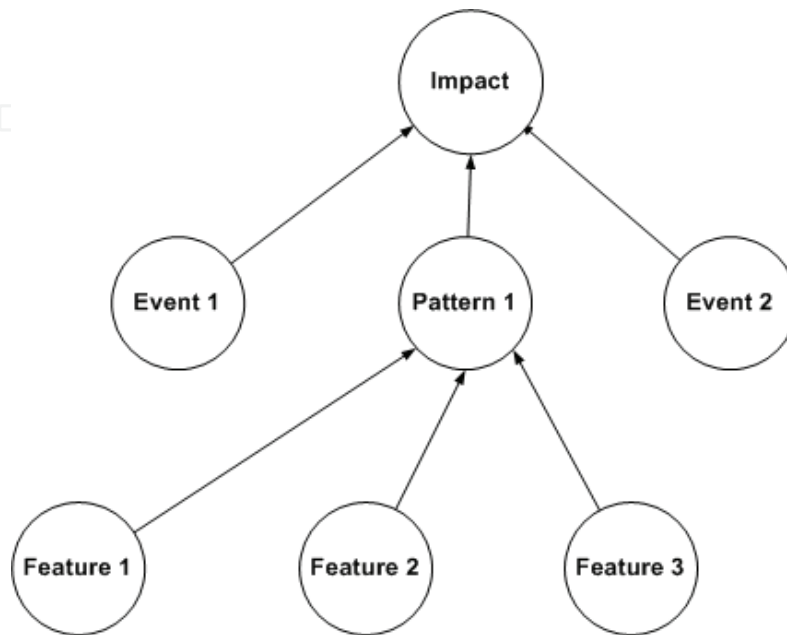

Fig. 3. Tree structure of levels of information provides an impact estimate.

## 5. Fuzzy Kalman filter

The Kalman filter is the standard estimation technique for dynamic systems. It is a measurement-driven technique that provides an estimate of the state representation of the object being observed and an associated uncertainty to that state. The Kalman filter, if properly designed, can incorporate various measurement types into the state vector as different sensor measurements and observations become known. The use of a fuzzy Kalman filter allows for nonnumeric information, as well as nontraditional information, to be mapped into the impact assessment object state. The ability to inject observations from these various information sources provides the proposed evidence accrual system the capability to determine understanding of impact.

The standard Kalman filter equations are given as

$$K = P_{k|k-1}H^T(HP_{k|k-1}H^T + R)^{-1} \quad (3a)$$

$$P_{k|k} = (I - KH)P_{k|k-1} \quad (3b)$$

$$P_{k|k} = (I - KH)P_{k|k-1} \quad (3c)$$

$$x_{k+1|k} = Fx_{k|k} \quad (3d)$$

$$P_{k+1|k} = FP_{k|k}F^T + Q_k \quad (3e)$$

If the measurements are represented as fuzzy membership functions, they cannot directly be incorporated into the Kalman equations. In (Watkins, 1994) it was shown that a fuzzy membership function can be incorporated into a linear vector equation through the relationship

$$\frac{\int (A + Bz)m_{adj}(z)dz}{\int m_{adj}(z)dz} = A + B \frac{\int z m_{adj}(z)dz}{\int m_{adj}(z)dz} = A + B \text{mom}_1(m_{adj}) \quad (4)$$

where  $m_{adj}$  is the informative fuzzy set of the measurement and  $\text{mom}_1$  indicates the first moment. From this development, it follows that the fuzzy measurement can be incorporated into the Kalman filter through the update equation, Eq. (3b) as

$$x_{k|k} = x_{k|k-1} + K(\text{mom}_1(m_{adj}) - Hx_{k|k-1}) \quad (5)$$

The incorporation of this uncertainty, also referred to as the measurement error covariance, significantly departs from the approach developed in (Watkins, 1994) where the argument is made that only measurements are fuzzy and all other components of a system are crisp. The uncertainty associated with a measurement is represented as a set of fuzzy membership functions. This results from modeling the quality of the reports provided as the lower level classifiers that feed the centralized classifier are incorporated. Often, these classifiers are given a linguistic quality score that must be mapped into a matrix of values to be processed by the Kalman filter. To incorporate the fuzzy membership representation of the uncertainty, it is noted that a linear matrix equation can also be considered a vector equation. The concept of Eq. (4) is again applied it to the Kalman gain equation, Eq. (3a). First, it is noted that

$$(HP_{k|k-1}H^T + R) \quad (6)$$

is a linear vector equation. Therefore, the fuzzy gain equation becomes

$$K = P_{k|k-1}H^T(HP_{k|k-1}H^T + \text{mom}_1(m_{adj}(R)))^{-1} \quad (7)$$

With these two methods of incorporating fuzzy logic into the Kalman filter iteration, the evidence accrual system can be developed.

## 6. Linear systems theory

The evidence accrual technique begins with the development of tree structure, as seen in Figure 3. In this simplified view of an impact assessment problem, the top node represents the final state of interest for the user. The lower nodes indicate the evidence state of information that is used to comprise the lower level data. The state vector of each node would be defined as

$$\mathbf{x} = [x_a \quad x_{s1} \quad x_{s2} \quad \dots \quad x_{sn}]^T \quad (8)$$

where  $x_a$  is the state of the impact object report while  $x_{si}$  are the subcomponents of the impact object that are created from information provided by the subnodes of Figure 3. This

information is injected into the system using the fuzzy Kalman filter (FKF). The state elements of the state vector represent the evidence or values of interest of the impact object. The final state,  $x_a$ , is always a level of evidence that represent the Level 3 fusion object that is reported to the end-user.

The evidence accrual system relies on the concept of first-order and low-order observers (Santina, 1994). In this approach, the state elements are decoupled. Most of the state elements related to the subnodes do not interact. Figure 4 provides a system diagram of this. The state elements can be updated using a scalar equation or first-order equation:

$$x(k+1) = f x(k) + \mathbf{g}^T \mathbf{y}(k) + \mathbf{h}^T \mathbf{u}(k) \tag{9}$$

For this evidence accrual application,  $\mathbf{u}(k)$ , the external input, is set to 0. When using the FKF rather than an observer, the gain  $\mathbf{g}$  associated with the measurement  $\mathbf{y}$  is the Kalman gain. If states are coupled, then a vector-matrix version of Eq. (8) is used. The benefit of this approach is that problem is decomposed into a number of smaller and more computationally simpler problems. The state  $x_a$  is the only coupled state. It has no direct observations. It is updated similar to the velocity state when only position information is available (Blackman, 1986).

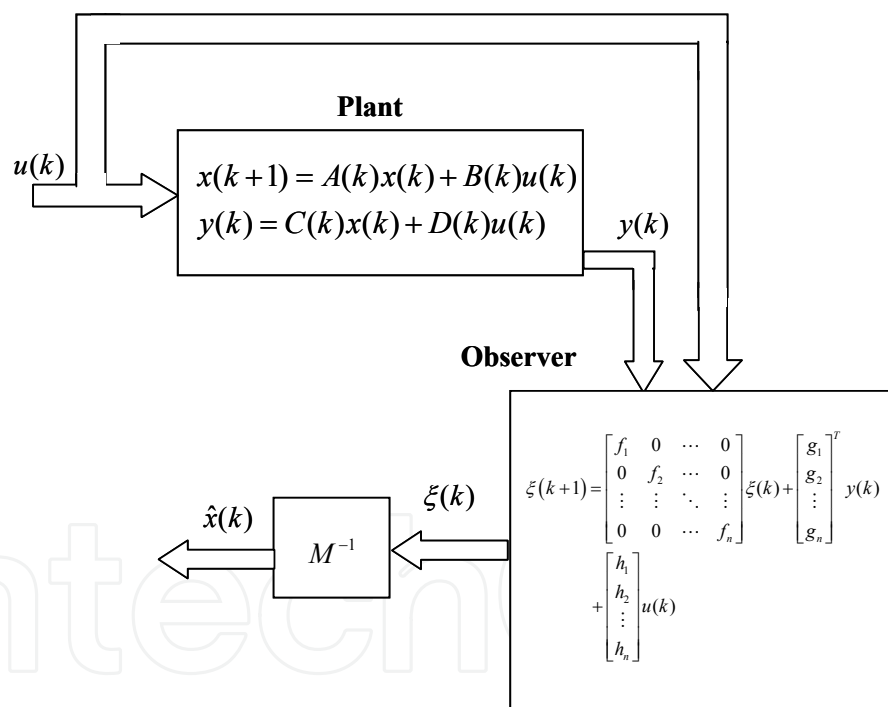

Fig. 4. The evidence accrual approach emulates the concept of first-order observers.

The dynamics of the system that is used to generate a state for a given node is given as

$$\mathbf{x}_{k+1} = \begin{bmatrix} f(x_a, x_{s1}, \dots, x_{sn}) \\ 0 & f_1 & 0 & \dots & 0 \\ 0 & 0 & \ddots & \ddots & \vdots \\ \vdots & \vdots & \ddots & \ddots & 0 \\ 0 & 0 & \dots & 0 & f_n \end{bmatrix} \mathbf{x}_k \tag{10}$$

The benefit of the first-order estimator is that each fusion object can be computed separately based on the available observations. The timestamp  $k$  is not an actual time but indicates an event. This approach is based on the implementation of scan reports in target tracking (Buczak & Uhrig, 1995) and event-driven control concepts used in engine control (Skjetne et al., 2002). This allows for the new information to be incorporated into the state vector and the state element  $x_a$  when it is available.

The significant function of Eq. (10) is  $f(\cdot)$ . This function maps the observation states into the evidence level for the given class. In this effort, a linear combination is assumed for the evidence combination of Eq. (10) and is defined as

$$x_k = f_a x_{a,k-1} + f_1 x_{s1,k-1} + \dots + f_n x_{sn,k-1} \quad (11)$$

In the covariance equation of the prediction, the relationship becomes

$$P_k = f_a P_{a,k-1} + f_1 P_{s1,k-1} + \dots + f_n P_{sn,k-1} + q_x \quad (12)$$

If the function  $f(\cdot)$  is nonlinear, the covariance equation becomes

$$P_k = \frac{df}{dx_a} P_{a,k-1} + \frac{df}{dx_1} P_{s1,k-1} + \dots + \frac{df}{dx_n} P_{sn,k-1} + q_x \quad (13)$$

The variable  $q_x$  indicates the quality of the evidence based on the combination. In other words, the level of understanding of the functional relationship of the various attributes to the classification of a given target type affects the size of the value of  $q_x$ . Poorer understanding inflates the value while greater understanding reduces it. The output value at any level can be a level of evidence or an actually computed value. This computed value may be a figure of merit or the output to an equation such as a position or velocity.

## 7. Evidence accrual for situation assessment of multiple targets

As part of system automation, the ability to understand the local issues is paramount. One part of this understanding is situation assessment of the coordination and independence of non-cooperative entities in one's region of interest. As seen in Figure 5, multiple targets are operating in a region. In operations, coordinated behavior can only be assumed based on observations. In this scenario, five targets are moving together in a formation. Three targets are traversing a road with one target not travelling in conjunction with the other two as its speeds vary. Finally, three targets appear to be converging on a specific point from different angles. The sampled track points are listed in Tables 1a and 1b. The reported classifications are shown in Tables 2a and 2b.

The kinematic Level 1 reports provide target track location and uncertainty as well as a classification with an associated quality, e.g., expressed as a value from 0 to 1 with 1 being absolute confidence. The second functional component will use location and classification metrics defined in (Stubberud et al., 2003b; Stubberud & Shea, 2003). These include a classification cardinality metric (Kelley, 1961), a classification Gap metric (Kelley, 1961), and a group distance metric for position and velocity (Stubberud et al., 2003b). The targets are defined as military vehicles including a transporter erector launcher (TEL). The classification of each target can be used to estimate composite groups to determine if the group falls within standard operational units.

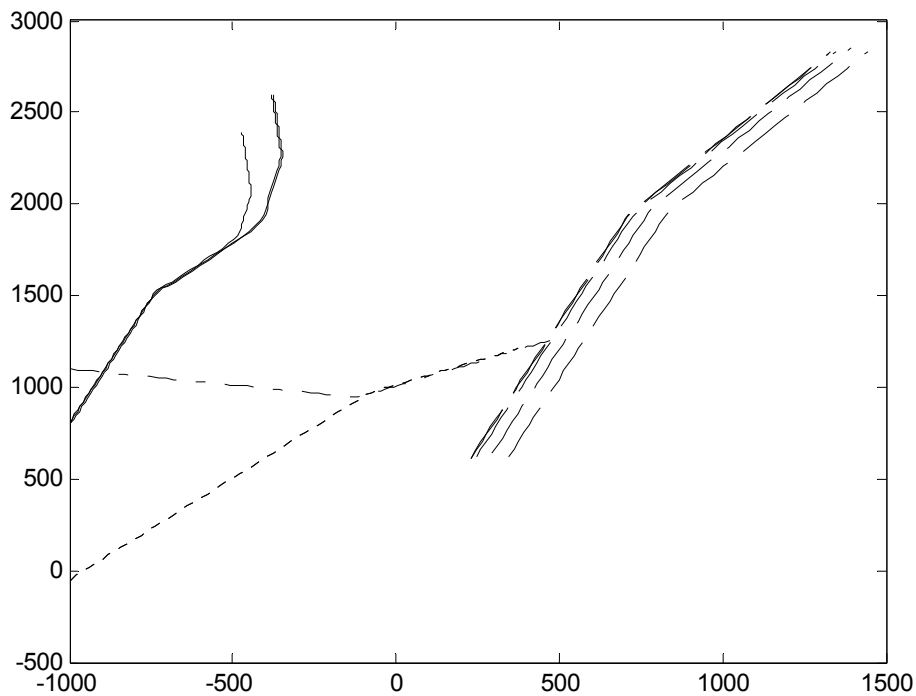

Fig. 5. Scenario of the multiple targets with multiple group relationships

The second component of the report consists of four separate estimates. The first is based on group position distance which was introduced in (Stubberud et al., 2003b):

$$\max \left\{ \min_{\mathbf{x}_j \in B} \left\{ \left\| \mathbf{x}_i - \mathbf{x}_j \right\|_2 : \forall \mathbf{x}_i \in A \right\}, \min_{\mathbf{x}_i \in A} \left\{ \left\| \mathbf{x}_i - \mathbf{x}_j \right\|_2 : \forall \mathbf{x}_j \in B \right\} \right\} \tag{14}$$

This is the distance between two groups of elements. The composite information to generate this measure is all of the position information for each target in each group. Thus, the overall position representation is defined as

$$\mathbf{x}_1(k+1) = \begin{bmatrix} \mathbf{A} \\ \mathbf{x}^{grp-a} \\ \mathbf{x}^{grp-b} \end{bmatrix} \tag{15}$$

where

$$\mathbf{A} = \max \left\{ \min_{\mathbf{x}_j^{grp-b} \in B} \left\{ \left\| \mathbf{x}_i^{grp-a} - \mathbf{x}_j^{grp-b} \right\|_2 : \forall \mathbf{x}_i^{grp-a} \in A \right\}, \min_{\mathbf{x}_i^{grp-a} \in A} \left\{ \left\| \mathbf{x}_i^{grp-a} - \mathbf{x}_j^{grp-b} \right\|_2 : \forall \mathbf{x}_j^{grp-b} \in B \right\} \right\}$$

with an associated Jacobian

$$\mathbf{F} = \begin{bmatrix} 0 & \frac{\partial \mathbf{B}}{\partial x^{grp-a}} & \frac{\partial \mathbf{B}}{\partial y^{grp-a}} & \frac{\partial \mathbf{B}}{\partial x^{grp-b}} & \frac{\partial \mathbf{B}}{\partial y^{grp-b}} \\ 0 & & & \mathbf{I} & \end{bmatrix} \tag{16}$$

where

$$\mathbf{B} = \left\| \mathbf{x}_i^{grp-a} - \mathbf{x}_j^{grp-b} \right\|_2.$$

Sample Time (sec)	Tgt 1	Tgt 2	Tgt 3	Tgt 4	Tgt 5	Tgt 6
0	-1000 800	-1000 804	-995 800	-1000 -50	-1000 -50	-1000 1100
5	-967.94 881.16	-994.97 805.56	-992.6 798.32	-929.39 30.504	-990.04 -31.861	-908.74 1083.1
10	-929.14 1005	-969.96 888.17	-974.9 866.03	-826.91 144.06	-903.38 60.31	-786.5 1064.5
15	-879.59 1121.1	-922.09 1013.1	-926.59 982.93	-720.16 257.78	-797.09 174.06	-660.02 1038.3
20	-838.35 1241.1	-875.77 1138.8	-879.74 1106.1	-620.98 371.09	-685.58 292.31	-537.36 1021.1
25	-792.35 1360.2	-830.91 1267.2	-835.48 1235.3	-517.83 484.78	-578.44 412.14	-414.49 998.34
30	-751.24 1480.3	-788.18 1391.6	-791.35 1363.7	-419.19 597.85	-479.7 526.85	-289.15 975.02
35	-697.14 1589.7	-739.37 1509.3	-749.56 1482.2	-317.17 705.01	-378.1 638.37	-164.82 954.34
40	-584.54 1711.8	-679.95 1607.5	-695.29 1588.7	-218.03 814.42	-275.83 754.74	-52.183 947.48
45	-450.22 1868.3	-588.07 1712.5	-582.82 1713.4	-113.9 928.98	-176.01 868.16	18.583 979.55
50	-361.77 2025.7	-486.21 1823.9	-445.21 1867.1	-22.073 1021.3	-77.271 971.9	75.327 1024.8
55	-330.41 2180.4	-430.93 1933.1	-358.23 2029.5	44.679 1059.6	3.4299 1039.1	132.23 1066.3
60	-326.35 2315.2	-419.91 2031.5	-323.35 2184.8	109.28 1082.8	69.283 1069.8	194.67 1108.9
65	-335.44 2381.7	-423.87 2115	-322.73 2316.4	171.46 1109.5	129.48 1094.1	258.27 1144.5
70	-352.8 2419.4	-432.05 2164.4	-338.43 2380.2	232.29 1142	193.17 1120	325.94 1181.7
75	-365.59 2453.2	-448.6 2212.4	-351.2 2416.4	296.07 1173.2	258.79 1152	390.58 1219.5
80	-372.93 2491.8	-458.18 2253.9	-363.07 2451.2	367.27 1205.3	324.08 1187	457.91 1252.5
85	-378.97 2537.1	-468.78 2299.8	-363.83 2494.7			

Table 1a. Track position reports for targets 1-6

Sample Time (sec)	Tgt 7	Tgt 8	Tgt 9	Tgt 10	Tgt 11
0	295.47 642.01	345.47 622.01	245.47 620.01	231.47 615.01	227.47 613.01
5	347.81 791.44	397.69 769.36	297.02 767.02	283.19 762.85	281.01 764.21
10	429.87 1010.8	476.82 991.62	385.29 980.21	365.23 984.62	363.77 982.36
15	503.7 1228.7	558.18 1207.1	460.68 1200.6	442.07 1198.3	439.14 1197.3
20	585.23 1442.7	636.46 1422	537.35 1416.5	523.16 1410.7	517.11 1414.9
25	664.36 1653.4	712.43 1631.2	615.04 1634.9	601.36 1628.2	593.51 1626.1
30	741.97 1866.8	792.38 1845.5	693.39 1849.6	678.65 1838.8	675.42 1838.6
35	832.38 2076.3	883.61 2060.4	783.71 2061.2	766.23 2057.3	765.41 2054.5
40	982.12 2305.6	1035.6 2286.5	935.04 2285.2	916.08 2281	912.81 2277.5
45	1153.2 2531.5	1201.6 2516.8	1106.3 2512.8	1088.9 2509.2	1083.9 2506.2
50	1327.1 2761.3	1371.7 2741.4	1274.6 2738.1	1256.3 2733.1	1255.6 2733.4

Table 1b. Track position reports for targets 7-11

Sample Time (sec)	Tgt 1	Tgt 2	Tgt 3	Tgt 4	Tgt 5	Tgt 6
5	Truck	Truck	Truck	TEL	Cmd	Fuel
10				TEL	APC	Fuel
20				TEL	Cmd	TEL
31	Truck	Truck	Truck			
35				TEL	Cmd	Fuel
45				TEL	Cmd	Fuel
60	Truck	Truck	Truck			

Table 2a. Classification reports for targets 1-6



Sample Time (sec)	Tgt 7	Tgt 8	Tgt 9	Tgt 10	Tgt 11
5	Tank	Tank	APC	APC	Cmd
10	Truck	Tank	APC	APC	Truck
20	Tank	Tank	Tank	APC	Truck
31					
35	Tank	APC	APC	APC	Fuel
45					
60					

Table 2b. Classification reports for targets 7-11

The Jacobian only has four elements based on the  $x$  and  $y$  coordinates of the two elements used for the difference. The second estimate is the velocity distance and has a similar state representation and Jacobian.

The composition estimate is similarly developed based on the norm of the cardinality metric

$$\text{card}(A) = \begin{cases} 0, & \text{if } A = \emptyset \\ n, & \text{if } A \neq \emptyset \text{ and } n = \# \text{ of elements in } A \end{cases} \quad (17)$$

which measures the difference in the number of elements of a classes in a group and the Gap metric

$$\sin \theta_{\max} \text{ where } \theta = \arccos \left( \frac{x^T y}{(x^T x)^{1/2} (y^T y)^{1/2}} \right). \quad (18)$$

which measures the ratio between the number of different classes of targets in a group.

The norm of the cardinality and the Gap compare the potential group compositions with known grouping compositions. The compositions are based on reported classifications of the targets.

For simplicity of implementation, in this example, potential groupings are only allowed when targets are within 300 m of each other. These three second component estimates provide the measurements to the third component estimation, the development of groupings levels of evidence. The third component estimator is a four state model

$$\mathbf{x}_{\text{evidence}} = \begin{bmatrix} (0.4x_{\text{pos}} + 0.3x_{\text{vel}} + 0.3x_{\text{comp}}) \text{sgn}(x_{\text{pos}}) \\ \begin{bmatrix} 1 & 0 & 0 \\ 0 & 1 & 0 \\ 0 & 0 & 1 \end{bmatrix} \begin{bmatrix} x_{\text{pos}} \\ x_{\text{vel}} \\ x_{\text{comp}} \end{bmatrix} \end{bmatrix} \quad (19)$$

where the estimates from position, velocity, and composition are mapped via fuzzy logic to levels of evidence, a value from 0 to 1. The fuzzy map for position distance (antecedent fuzzification function, inference engine, and consequence Defuzzification function) is given in Figure 6.

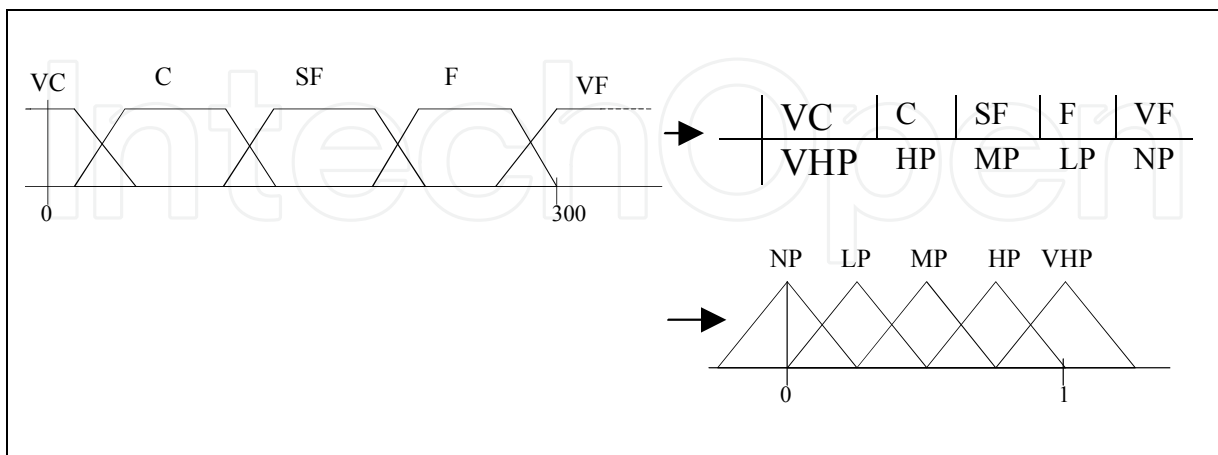

Fig. 6. Fuzzy map for position distance

The notation in the antecedent functions indicate targets are very close (VC), close (C), somewhat far (SF), far (F), and very far (VF). In the consequence function, no probability (NP), low probability (LP), medium probability (MP), high probability (HP), and very high probability (VHP). A similar map is defined for velocity. A two dimensional inference engine that uses the cardinality and the Gap have been defined as well. The initial covariance  $\mathbf{P}$  was set to  $10\mathbf{I}$ . The process noise was defined as

$$\mathbf{Q} = \begin{bmatrix} 0.1 & 0 & 0 & 0 \\ 0 & 10 & 0 & 0 \\ 0 & 0 & 10 & 0 \\ 0 & 0 & 0 & 10 \end{bmatrix}. \quad (20)$$

The second component estimates are updated with each track report. The third component estimate updates the observations only when a report is provided. The overall estimate is updated when any observation is reported. The initial values for the various groupings of targets are set to 0. If an evidence score is greater than 0.6, then it is reported as a grouping. The largest grouping with such a score is reported.

The results for the Figure 5 scenario are shown in Table 3 and reflect the estimated situation assessment over the course of the scenario. Without velocity information and composition information, no groups can be formed.

Once the velocity information and composition information is provided, the initial groupings can be formed. The group of five targets always uses position and velocity to maintain its relationship while the composition strengthens and weakens the relationship. Target 1 separates early from Target 2 and 3 and the other two do not keep pace. The convoy of truck composition increases the evidence to generate a relationship. Near the end of the scenario, Target 3 closes in and then keeps pace with Target 1 while Target 2 moves away. While the evidence level was close to the threshold, it did not maintain its grouping level. Finally, Targets 4 and 5 almost come together based on composition and position early

on but clearly remain apart as the second composition report and velocity are below threshold. After the velocity relationship improved, Targets 4 and 5 form a group. As Target 6 approaches the group, it uses position and composition to create the larger group.

Time	Group 1	Group 2	Group 3	Group 4	Group 5	Group 6
0	No Groups					
5	1,2,3	4	5	6	7,8,9,10,11	
10	2,3	1	4	5	6	7,8,9,10,11
20	1,2,3	4,5	6	7,8,9,10,11		
30	1,2,3	4,5	6	7,8,9,10,11		
35	1,2,3	4,5	6	7,8,9,10,11		
45	2,3	1	4,5	6	7,8,9,10,11	
50	2,3	1	4,5,6	7,8,9,10,11		
60	1,3	2	4,5,6	7,8,9,10,11		
80	1,3	2	4,5,6	7,8,9,10,11		

Table 3. Groupings based on evidence levels of 0.6 trashold.

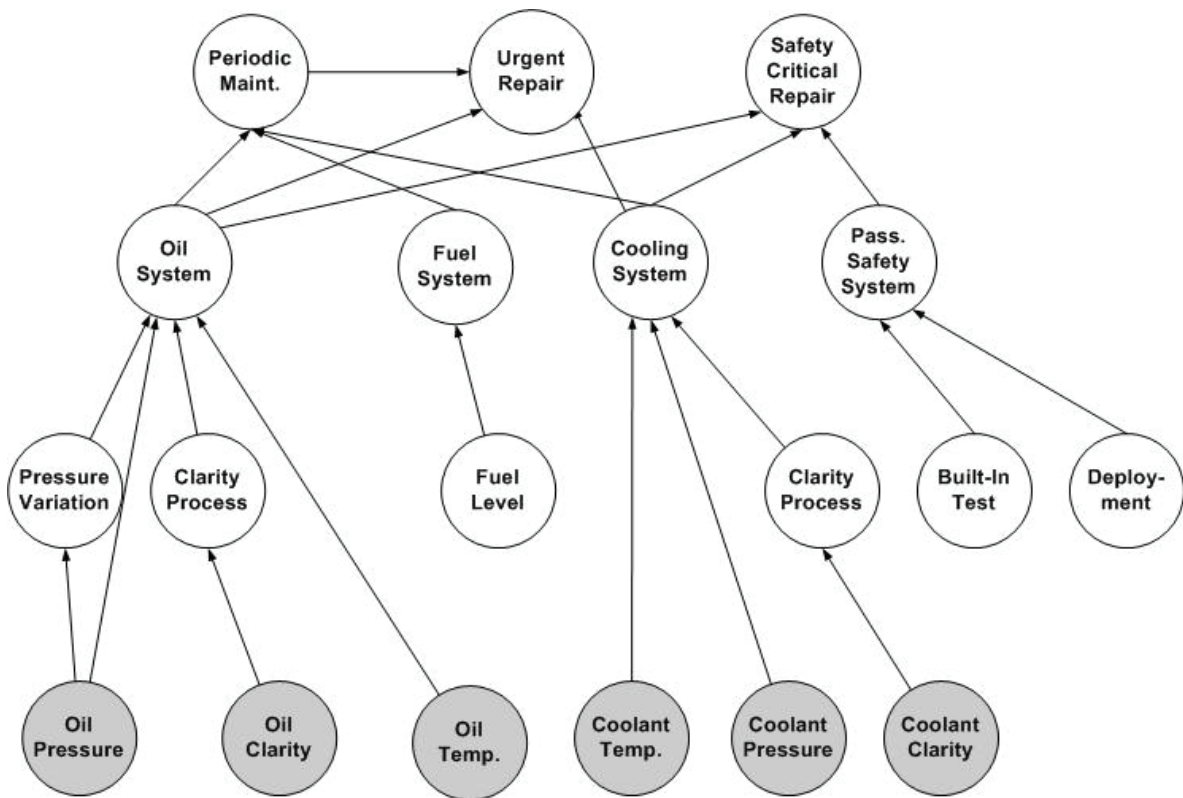

Fig. 7. Basic tree structure for engine health monitoring.

## 8. Condition-based health monitoring example

Another application of this evidence accrual technique is that of condition based monitoring. As described in (Liggins et al., 2009), many systems, such as helicopters (Brotherton et al., 2002), UAVs, and automobile engines, have various sensors throughout the vehicle to monitor the current operating conditions of the vehicle. By combining the data from these sensors, the health state of the vehicle can not only be determined but also in some instances predicted. In this example, an automobile with sensors on the cooling system, the oil system, the fuel system, and passenger safety system is used. The individual systems are examined to determine their performance to provide the final recommendation of the need for periodic maintenance, urgent repairs, and safety critical repairs. In Figure 7, the basic tree structure is shown. The gray-filled node, indicate basic sensors. Each subsystem of the car creates it own branch of the tree structure.

The oil system branch has three sensors: oil pressure, which is quite accurate, the oil temperature, which is also accurate, and an optical sensor to measure the oil clarity which is not very accurate. The pressure sensor feeds a change in pressure calculation as well as provides a direct measurement to the evidence accrual system. The temperature sensor is a direct input to the evidence level. The clarity sensor is the input to a more complex system that determines the level of particular content in the oil. The oil system state representation is given by

$$\mathbf{x}_{oil\_sys} = \begin{bmatrix} x_{oil\_ch} & x_{oil\_pr} & x_{var} & x_{clarity2} & x_{clarity} & x_{temp} & x_{press} \end{bmatrix}^T \quad (21)$$

where

$$\begin{aligned} x_{oil\_ch} &= 1 - e^{-x_{clarity2}/1.5} \\ x_{oil\_pr} &= \max(1, 0.6r1 + 0.7r2 + 0.9r3 + 0.9r4) \\ x_{clarity2} &= f(x_{clarity}) \end{aligned}$$

where

$$x_{var} = \frac{x_{press}(t) - x_{press}(t - \Delta t_{sec})}{\Delta t_{sec}}$$

and  $f$  is system that provides a level of clarity.

The fuel system branch has one sensor, the fuel level gauge which is not very accurate. This sensor provides both a direct measurement of the fuel level and a change in fuel level. The state representation is given as

$$\mathbf{x}_{fuel\_sys} = \begin{bmatrix} x_{fue\_ch} & x_{gauge} \end{bmatrix}^T \quad (22)$$

where

$$x_{fue\_ch} = \mu(-x_{gauge} - 0.25).$$

The cooling system has three sensors, a temperature sensor, which is very accurate, a pressure gauge which is accurate, and a clarity sensor similar to that of the oil system. The

temperature and pressure sensors provide direct input to the evidence accrual system. The clarity sensor again goes through a more complex system. The state representation is given as

$$\mathbf{x}_{cool\_sys} = \begin{bmatrix} x_{cool\_ch} & x_{cool\_pr} & x_{clarity2} & x_{clarity} & x_{temp} & x_{press} \end{bmatrix}^T \quad (23)$$

where

$$\begin{aligned} x_{cool\_ch} &= 1 - e^{-x_{clarity2}/1.5} \\ x_{oil\_pr} &= \max(1, 0.6r1 + 0.9r3 + 0.9r4) \\ x_{clarity2} &= f(x_{clarity}) \end{aligned}$$

where all terms are the same as for the oil system except

$$\begin{aligned} r1 &= r1 + x_{cool\_ch}^3 * \mu(\Delta t_{days} - 200) \\ r4 &= \left(1 - \mu(x_{press} - 20) + \mu(x_{press} - 120)\right) \end{aligned}$$

The passenger safety system has two sensors, a built-in test at start-up to check that the system has been activated and a simple deployment sensor. The first sensor checks to see if the airbag deployment system is operational. For the latter sensor, if any of the airbags have been deployed without being replaced, then it is set off. The state representation of the safety system is given as

$$\mathbf{x}_{pass\_afety\_sys} = \begin{bmatrix} x_{safety\_ch} & x_{deployed} & x_{sys\_test} \end{bmatrix}^T \quad (24)$$

where

$$x_{safety\_ch} = \delta\left(\left(1 - x_{deployed}\right)\left(x_{sys\_test}\right)\right).$$

The benefit of the evidence accrual system defined in this chapter is that the reporting evidence can be considered independent or interactive. In this case, the structure allows for periodic maintenance to also provide input into the urgent repairs while the safety issues are completely stand alone. The evidence state for periodic maintenance is defined as

$$x_{per\_mat} = \max\left(1, 0.8x_{oil\_ch} + 0.9x_{fuel\_ch} + 0.8x_{cool\_ch}\right),$$

while the urgent repairs is given as

$$x_{urgent\_repairs} = \max\left(1, 0.8x_{oil\_ch} + 0.9x_{cool\_ch} + 0.3x_{per\_mat}\right).$$

The safety system state is given as

$$x_{safetys} = \max\left(1, 0.5x_{oil\_ch} + 0.8x_{cool\_ch} + x_{pass\_safety\_sys}\right).$$

For the first example will look at an oil system problem. The oil clarity over time is given as seen in Figure 8. The oil pressure is given as described in Figure 9. The clarity clearly over

time degrades. This indicates that periodic maintenance is needed. Near the end of the operations, the oil pressure has spikes in the negative direction. While the oil pump and engine maintain pressure, the amount of oil has decreased such that turns induce a drop in the oil pressure indicating a potential major fault.

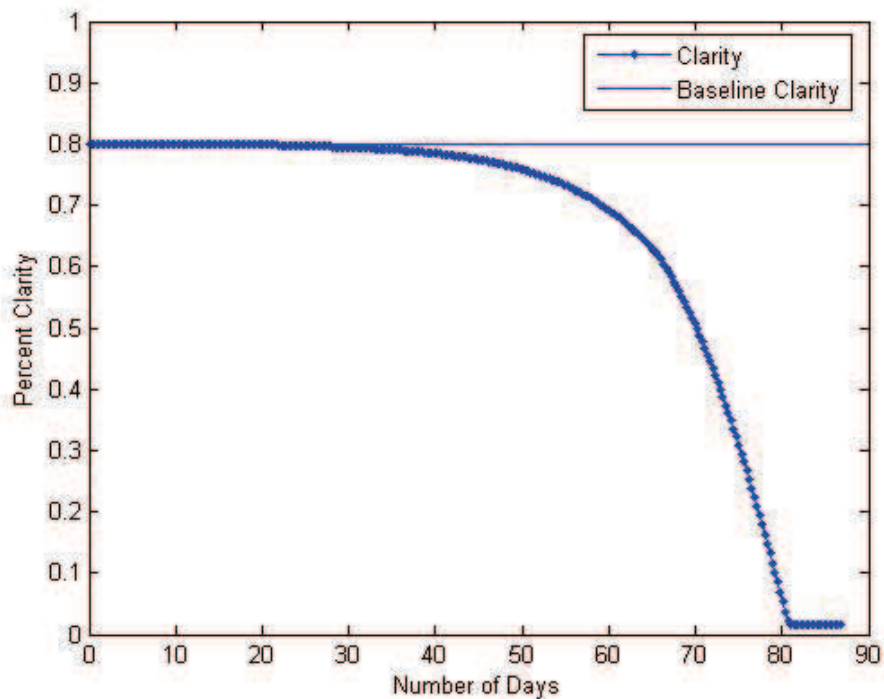

Fig. 8. Oil clarity over time.

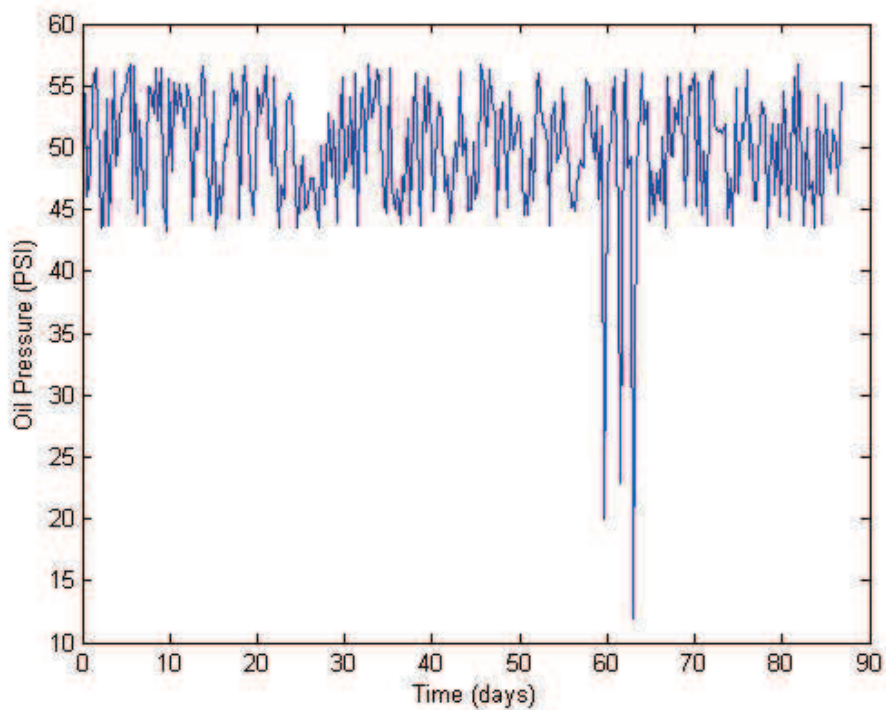

Fig. 9. Oil pressure over time.

Table 4 shows sampled results of the system. This indicates that, at first, the automobile is fine but soon needs periodic maintenance. Over time, the oil pressure problem plus the ignoring of the need for periodic maintenance signals the need for urgent repairs.

	Day 0	Day10	Day 40	Day 59	Day 70
Oil Clarity	0.8	0.8	0.775	0.7	0.4
Oil Clarity 2	0	0	0.09	0.12	0.62
Oil Pressure	54.5	44.7	47.6	26	48.1
Oil Variation	3	2.6	2.8	32	10
Oil Change	0.0	0.0	0.058	0.077	0.339
Oil Problem	0	0	0	1	1
Periodic Maintenance	0	0	0.048	0.061	0.26
Urgent Repair	0	0	0	0.83	0.91

Table 4. Selected results of the oil system.

## 9. Conclusion

A fuzzy evidence accrual technique for data fusion as applied to mechatronics was developed. The technique incorporates multiple sensor inputs and uncertainty measures.

## 10. References

- Blackman, S. (1986). *Multiple-Target Tracking with Radar Applications*, Artech House, ISBN 0890061793, Norwood, MA, USA
- Blackman, S. & Popoli, R. (1999). *Design and Analysis of Modern Tracking Systems*, Artech House, ISBN 1580530060, Norwood, MA, USA
- Brotherton, T.; Grabill, P.; Wroblewski, D.; Friend, R.; Sotomayer, B. & Berry, J. (2002). A Testbed for Data Fusion for Engine Diagnostics and Prognostics, *Proceedings of the 2002 IEEE Aerospace Conference*, pp. 6-3029 - 6-3042, ISBN 0-7803-7231-X, Big Sky, MT, USA, March 2002.
- Buczak, A.L. & Uhrig, R.E. (1995). Hierarchical Fuzzy Genetic Method for Information Fusion, *Intelligent Engineering Systems through Artificial Neural Networks*, Vol. 5: Fuzzy Logic and Evolutionary Programming (*Proceedings of the Artificial Neural Networks in Engineering Conference*), pp. 357-362, ISBN 0791800482, St. Louis, MO, USA, November 1995.
- Chen, C.H. (1996). *Fuzzy Logic and Neural Network Handbook*, McGraw-Hill, ISBN 0-07-011189-8, New York, NY, USA.
- Dempster, A. (1967). Upper and Lower Probabilities Induced by a Multivalued Mapping, *Annals of Mathematical Statistics*, Vol. 38, No. 2, (April 1967), pp. 325 - 339, ISSN 0003-4851

- Hall, D. & Llinas, J. (2001). *The Handbook of Multisensor Data Fusion*, CRC Press, ISBN 0-8493-2479-7, Boca Raton, FL, USA.
- Hammell, R.J. & Sudkamp, T. (1998). Learning Fuzzy Rules from Data, NATO RTO Meeting Proceedings 3: The Application of Information Technologies (Computer Science) to Mission Systems, pp. 8-1– 8-10, ISBN 92-837-1006-1, Monterey, CA, USA, April 1998.
- Kelley, J.L. (1961). *General Topology*, D. Van Nostrand Company, ISBN 0923891552, Princeton, New Jersey, 1961.
- Kosko, B. (1992). *Neural Networks and Fuzzy Systems: A Dynamical Systems Approach to Machine Intelligence*, Prentice Hall, ISBN 0136114350, Englewood Cliffs, New Jersey, USA
- Le Hegarat-Mascle, S.; Bloch, I. & Vidal-Madjar, D. (1997). Application of Dempster-Shafer Evidence Theory to Unsupervised Classification in Multisource Remote Sensing, *IEEE Transactions on Geoscience and Remote Sensing*, Vol. 35, No. 4, (July 1997), pp. 1018 - 1031, ISSN 0196-2892
- Liggins, M.E.; Llinas, J. & Hall, D. L. (2009). *Handbook of Multisensor Data Fusion: Theory and Practice*, Second Edition, CRC Press, ISBN 1420053086, Boca Raton, FL, USA
- Llinas, J.; Bowman C.; Rogova, G.L.; Steinberg, A.; Waltz, E. & White, F. (2004). Revisions and Extensions to the JDL Data Fusion Model II, *Proceedings of Fusion 2004*, pp.1218-1230, ISBN 91-7056-117-6, Stockholm, Sweden, July 2004.
- Pearl, J. (1988). *Probabilistic Reasoning in Intelligent Systems: Networks of Plausible Inference*, Morgan Kaufmann Publishers, ISBN 1558604790, San Mateo, CA, USA
- Santina, M.S.; Stubberud, A.R. & Hostetter, G.H. (1994). *Digital Control System Design* 2nd Edition, Saunders College Publishing, ISBN 0030760127, Fort Worth, Texas, USA
- Shafer, G. (1976). *A Mathematical Theory of Evidence*, Princeton University Press, ISBN 978-0691100425, Princeton, N.J., USA
- Skjetne, R.; Teel, A. R. & Kokotovic, P.V. (2002). Nonlinear Maneuvering with Gradient Optimization, *Proceedings of the 41st IEEE Conference on Decision and Control* 2002, pp. 3926-3931, ISBN 0-7803-7516-5, Las Vegas, NV, USA, December 2002
- Steinberg A.; Bowman, C. & White, F. (1999). Revisions to the JDL Data Fusion Model, *Proc. of the SPIE Sensor Fusion: Architectures, Algorithms, and Applications III*, pp. 430-441, ISBN 0-8194-3193-1, Orlando, FL, USA, April 1999.
- Stewart, G.W. & Sun, J. (1990). *Matrix Perturbation Theory*, Academic Press, ISBN 0126702306, Boston, MA, USA
- Stubberud S. & Kramer, K. (2007). Incorporation of Partially Observable Evidence into an Evidence Accrual Data Fusion Technique, *Proceedings of the Third International Conference on Intelligent Sensors, Sensor Networks and Information Processing*, pp. 251 - 256, ISBN 978-3-540-38619-3, Melbourne, Australia, December 2007.
- Stubberud S. & Kramer, K (2008). Incorporation of Indirect Evidence into an Evidence Accrual Technique for Higher Level Data Fusion, *Signal Processing, Sensor Fusion, and Target Recognition XVIII Proceedings of the SPIE*, Volume 6968. pp. 696811-696811-12, ISBN: 9780819471598, Orlando, FL, USA, April 2008.
- Stubberud, S. & Shea, P.J. (2003). More Metrics for Level Fusion Association, *Proceedings of the 16th International Conference on Systems Engineering*, pp. 657-663, ISBN 0-905949-91-9, Coventry, UK, September 2003.



- Stubberud, S.; Shea, P.J. & Klamer, D. (2003). Data Fusion: A Conceptual Approach to Level 2 Fusion (Situational Awareness), Proceedings of SPIE, Aerosense03, pp. 455-462, ISBN 0-8194-4956-3, Orlando, FL., April 2003.
- Stubberud, S.; Shea, P.J. & Klamer, D. (2003). Metrics for Level 2 Fusion Association, Proceedings of Fusion 2003, pp. 180-186, ISBN 0-9721844-4-9, Cairns, Australia, July 2003.
- Watkins, F.A. (1994). Fuzzy Engineering, Ph.D. thesis, University of California Irvine, Department of Electrical and Computer Engineering, June 1994

IntechOpen

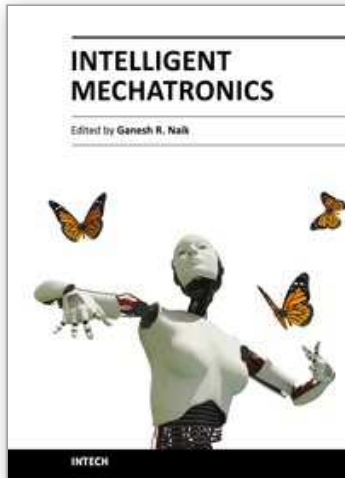

## **Intelligent Mechatronics**

Edited by Prof. Ganesh Naik

ISBN 978-953-307-300-2

Hard cover, 248 pages

**Publisher** InTech

**Published online** 28, February, 2011

**Published in print edition** February, 2011

This book is intended for both mechanical and electronics engineers (researchers and graduate students) who wish to get some training in smart electronics devices embedded in mechanical systems. The book is partly a textbook and partly a monograph. It is a textbook as it provides a focused interdisciplinary experience for undergraduates that encompass important elements from traditional courses as well as contemporary developments in Mechatronics. It is simultaneously a monograph because it presents several new results and ideas and further developments and explanation of existing algorithms which are brought together and published in the book for the first time.

### **How to reference**

In order to correctly reference this scholarly work, feel free to copy and paste the following:

Stephen C. Stubberud and Kathleen A. Kramer (2011). An Evidence Accrual Data Fusion Technique for Situational Assessment, Intelligent Mechatronics, Prof. Ganesh Naik (Ed.), ISBN: 978-953-307-300-2, InTech, Available from: <http://www.intechopen.com/books/intelligent-mechatronics/an-evidence-accrual-data-fusion-technique-for-situational-assessment>

**INTECH**  
open science | open minds

### **InTech Europe**

University Campus STeP Ri  
Slavka Krautzeka 83/A  
51000 Rijeka, Croatia  
Phone: +385 (51) 770 447  
Fax: +385 (51) 686 166  
[www.intechopen.com](http://www.intechopen.com)

### **InTech China**

Unit 405, Office Block, Hotel Equatorial Shanghai  
No.65, Yan An Road (West), Shanghai, 200040, China  
中国上海市延安西路65号上海国际贵都大饭店办公楼405单元  
Phone: +86-21-62489820  
Fax: +86-21-62489821

© 2011 The Author(s). Licensee IntechOpen. This chapter is distributed under the terms of the [Creative Commons Attribution-NonCommercial-ShareAlike-3.0 License](#), which permits use, distribution and reproduction for non-commercial purposes, provided the original is properly cited and derivative works building on this content are distributed under the same license.

IntechOpen

IntechOpen