

We are IntechOpen, the world's leading publisher of Open Access books Built by scientists, for scientists

4,800

Open access books available

122,000

International authors and editors

135M

Downloads

Our authors are among the

154

Countries delivered to

TOP 1%

most cited scientists

12.2%

Contributors from top 500 universities

**WEB OF SCIENCE™**Selection of our books indexed in the Book Citation Index
in Web of Science™ Core Collection (BKCI)

Interested in publishing with us?
Contact book.department@intechopen.com

Numbers displayed above are based on latest data collected.

For more information visit www.intechopen.com

Emergence of Matured Chaos During, Network Growth, Place for Adaptive Evolution and More of Equally Probable Signal Variants as an Alternative to Bias p

Andrzej Gecow
Centre for Ecological Research PAS
Poland

1. Introduction

This introduction describes contemporary investigations and interpretations of Kauffman networks, especially in the context of the 'life on the edge of chaos' hypothesis. The Kauffman networks are known as Boolean networks. They were introduced by Kauffman (1969), and later investigated and developed by many authors. These networks take various forms, e.g. cellular automata which stress the spatial order of their nearest neighbours as connection pattern. I will not consider such specific forms. Generally, this approach for the description of living systems, or a system designed by humans, using dynamical directed networks is now one of the most attractive and promising tools. His 'The Origins of Order' (Kauffman, 1993) is a large summary of first period Boolean network investigations and a base for the usually agreed on 'life on the edge of chaos' hypothesis. Later this hypothesis was 'experimentally verified' using the Gene Regulatory Network model (Rämö et al., 2006; Serra et al., 2004; 2007; Shmulevich et al., 2005; Wagner, 2001) but in this paper I call into question this verification. My explanation is based on an interpretation where stability and chaos play the main role. This introduction is designed as a description of Kauffman networks and their variants and extensions, in order to make my arguments comprehensible. No previous knowledge about the Kauffman network is assumed.

1.1 Elements, structure, functions and parameters of Boolean networks

In Fig. 1 the depicted Boolean network is small. It consists of $N = 5$ nodes named G, E, A, P and S . I show here a simple, imagined gene regulatory network of a plant. Node G describes the decision: 'to grow, or not to grow'. It depends on two detected parameters of the environment: w - warm - temperature sufficient for growth; and l - sufficient day length. In the winter it is not warm ($w = 0$ means: false) and days are short ($l = 0$) which is the environment state at time 0 shown in the Table on the left. For the decision 'to grow' ($g = 1$) both warmth ($w = 1$) and spring ($l = 1$) are needed which is calculated using Boolean function AND ($g := l \text{ AND } w$) performed by node G . Input signals l and w are taken as they are at time step t but a result g appears in the next ($t + 1$) time step. Such an updating scheme is called 'synchronous mode'. There are a few updating schemes, but for the main questions this fact it is not very important (Gershenson, 2004). The result g of node function calculation is

called 'state of node' G . It also is an output signal of node G which is sent to other nodes as their input signals through output links of node G . There is $k = 2$ of output links (also called outputs) of node G . Number k for a particular node of network can be any, it is called 'node degree'. Distribution of node degree k for a particular network defines the network type. It will be discussed later. It is easy to add or remove an output link of node in Boolean network because it does not change node function. The input signals l and w come to node G through its input links. Arrows show direction of signal movement through the link, therefore the network is 'directed'.

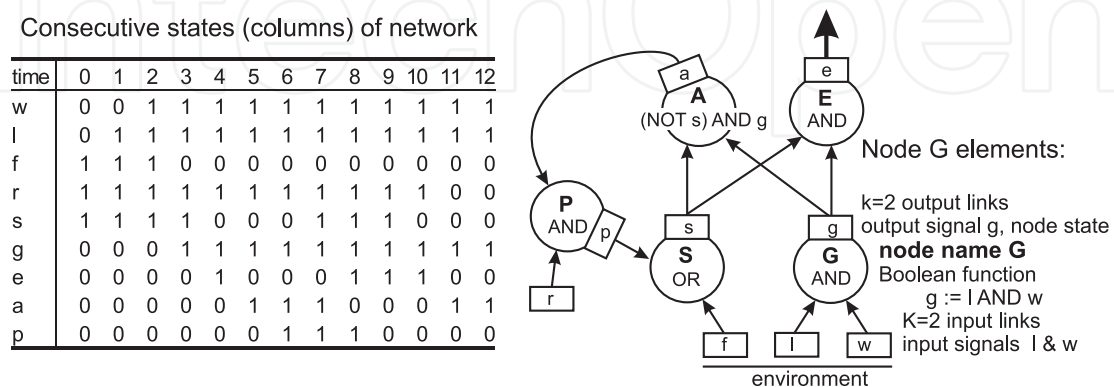

Fig. 1. Example of Boolean network, its basic elements (on the right) and function (on the left).

Node G has $K = 2$ input links (also called inputs). Usually is assumed that each node of the network has the same fixed number K of input links. It is a useful approximation and I use it also, but more recently flexible K in one particular network is often used. It is not so easy to add or remove node input while simulation of the Boolean network is being processed because it changes the number of function variables and in effect it changes the node function. Fortunately, Serra et al. (2007) prove that distribution of damage size depends upon the distribution of k only, and does not depend upon the topology of the inputs.

The environment also contains substrate f . This substrate is present in the plant (s) if it is present in the environment ($f = 1$) OR produced by the plant (p) using its internal reserve (r). As can be seen in the table, substrate f is present in the environment at the beginning and the plant also has a reserve r for the production of p . An effect e of the 'to grow' (g) decision can occur if substrate s is present in the plant which depicts node E . However, if the decision g is taken but substrate s is absent ($s = 0$) which happens at time step 4, then alarm a happens in the next time step. If alarm a occurs, then the plant can use its reserve r and produce substitute substrate p which is ready at time step 6. But because of the restriction taken before (e.g. $K = 2$ for all nodes) and rules it can be available for E and A only at time step 7 as s signal (the result of OR operation which takes a time). Effect e which disappeared at step 5 next appears at time 8. Check the table of network states - it is defined by state in time 0 and network structure with node functions. Such network is deterministic. The annealed approximation model discussed in Ch.2.2.3 is not deterministic (Derrida & Weisbuch, 1986).

1.2 Attractors, damage and chaos-order boundary

1.2.1 Attractors and their basins

A network contains a finite number N of nodes. The space of states of such a finite Boolean network also is finite and the network (system) must meet some previously left state in the finite number of time steps. In a deterministic network, from this time step the sequence of

states must repeat ad infinitum. This repeated sequence of network states is called 'attractor'. It can be 'point attractor' if it is one stable state, otherwise it is circular attractor. One system (network) typically has lot of attractors. Not all of the system (network) states are elements of any attractor, but starting from any system state the network always reaches some attractor. The set of states leading to a particular attractor is called 'basin of attraction'. Kauffman (1969) has proposed that different types of cells in the animal body are an effect of different attractors of its common gene regulatory network (see also (Serra et al., 2010)). Therefore number and length of attractors for a network with a particular set of parameters is one of the main investigated themes.

1.2.2 Damage spreading in chaotic and ordered systems

If we start two identical deterministic systems A and B from the same state, then they will always have identical states. However, if a small disturbance is introduced in one of them (B), e.g. a changed state of one node, then some difference in node states between two such previously identical systems appears as an effect. These differences are called 'damage' (Jan & Arcangelis, 1994) (or 'perturbations' (Rämö et al., 2006; Serra et al., 2004)). The damage is measured as a fraction of all N nodes which have a different state than in the not disturbed network and in this article are denoted by d . Note, $0 < d < 1$. I will also use damage measured on $m = 64$ network external outputs in number L of changed output signals.

Damage can take various forms, e.g. it describes typically: epidemic spreading (Grabowski & Kosiński, 2004), opinion formation (Fortunato, 2005; Grabowski & Kosiński, 2006; Sousa, 2005) and attack or error effects (Crucitti et al., 2004; Gallos et al., 2004). However, these networks are not usually directed networks, and their important aspect is the spatial description which uses a particular lattice shape in the form of 'cellular automata'.

The main characteristic of the chaotic (term: 'pseudochaotic' can be also found (Serra et al., 2010)) behaviour of dynamical systems is high sensitivity to initial conditions. For chaotic systems (I use the term 'chaos' as Kauffman (1993) does) a small initiation of damage typically causes a large avalanche of damage which spreads onto a big part of the finite system and ends at an equilibrium level. The existence of this limitation is the main difference between this 'chaos' and the more commonly taken definition (Schuster, 1984) used for continuous arguments of a function. Levels of damage equilibrium are discussed in Ch.2.2.3 on a base of annealed approximation (Derrida & Pomeau, 1986; Kauffman, 1993).

High stability of ordered systems does not allow for damage to evolve into a large avalanche. There could be a very small avalanche in 'small unfrozen lakes of activity' which I do not call 'avalanche', especially not a 'large avalanche'. However, it is only statistical law, and theoretically large avalanche can happen but not practically for randomly constructed networks. Unfortunately, Serra et al. (2004) have introduced on credit term 'avalanche' which is consequently used later (Rämö et al., 2006; Serra et al., 2010; Shmulevich et al., 2005), for damage size in range especially small 'avalanches', e.g. 0 to 6 damaged nodes. This credit can be paid by damage in range of chaotic behaviour. I will come back to the view of 'frozen' areas, for the time being I want to introduce (fully in Ch.2.2.1 and in (Gecow, 1975; Gecow & Hoffman, 1983; Gecow, 2008) see also (Aldana et al., 2003; Serra et al., 2004)) 'coefficient of change multiplication on one node' also called 'coefficient of damage propagation' which simply shows why and when damage should grow. If a node has k outputs and on one input damage appears (changed input signal comparatively to undisturbed system), then on the average, $w = k/2$ outputs will be changed (damaged). Note that for $k = 2$ $w = 1$ which means that damage does not grow. For this coefficient a random function is assumed. Equal

probability of both signals in Boolean network is also assumed. For completion 'internal homogeneity' P (Kauffman, 1993) should be kept minimal. The internal homogeneity P of a Boolean function is defined as the fraction of the 2^K positions with 1 values or with 0 values depending on which fraction is higher, (P always is greater than 50 %) (Kauffman, 1993). If these assumptions are not true, then typically $w < k/2$. If K is fixed for an autonomous network (without external links from and to environment), then the average k is equal to K ($\langle k \rangle = K$). For such a network $K = 2$ is a boundary of the radically different behaviour, which Derrida & Pomeau (1986) has found. This is called 'phase transition' - for $K > 2$ it is the chaotic phase where damage typically grows and for $K < 2$ it is an ordered phase where even large damage typically fades out.

"Harris et al. (2002) pointed out that most biological systems tend to make use of a regulatory systems which, in the Boolean approximation, is described by canalising functions. ... A Boolean function is said to be canalising if at least one value of one of its inputs uniquely determines its output, no matter what the other input values are. Real gene networks show a proportion of canalising functions much higher than the one corresponding to a uniform choice" (Serra et al., 2004) (i.e. for $K=2$ without XOR and NOT XOR).

An assumption of equal probability of both signals is too strong and from the beginning bias p - probability of one signal variant is considered. This method of description however, is not universal and I introduce an alternative which differs in interpretation and results. It is more than two equally probable signal variants which is one of the main themes of this article.

1.2.3 Stability types, spontaneous order and negative feedbacks

There are four similar terms used in the Kauffman approach which should be clearly separated: 'structural stability', 'homeostatic stability', 'ultrastability' and 'spontaneous order'.

The 'structurally stable systems' (Kauffman, 1993) evolve in correlated landscape (e.g. of fitness) which typically allows the small initial change to give a small change as its effect. This landscape is considered on a space of system parameters where the nearest neighbours vary by the smallest change of connection, function or state. It means that such neighbours are similar and they function similarly. Chaotic systems are not 'structurally stable'. They evolve in uncorrelated landscape where small change typically causes crossing many 'walls of bifurcation', radically changing the system's properties (e.g. adding a new basin of attraction). Functions of neighbours typically are not similar (large damage avalanche means just this).

Adaptive evolution needs small changes. Large change usually lost collected aptness (fitness). Kauffman's approach, therefore, looks for such a 'structurally stable' area and found that it occurs between the chaotic and ordered phase. For this reason in Kauffman's approach, the phase transition between chaos and order is one of the most important themes of the investigation. Kauffman isolates this area on the basis of effects for the evolvability and structure of fitness landscape as a third region called 'liquid'. This region lies between 'solid' (because frozen, i.e. constant states of nodes) ordered region and 'gas' - a chaotic region. "Landscape is very rugged in the chaotic regime. This ruggedness is a direct consequence of the fact that damage spreads widely in networks in the chaotic regime. Almost any single mutation will dramatically alter landscape structure" (Kauffman, 1993). Note - though not all mutation will cause a large alteration. A liquid region lies on formally ordered and chaotic regions and its boundaries are smooth and not well defined. John Holland (1998) named this region 'the edge-of-chaos membrane' but Serra et al. (2007) - the 'critical' state, zone or regime.

After a small initiation of damage the effected damage (perturbation, change) can be large or small. Minimizing of initiation's effect defines a homeostatic feature. Typical homeostatic mechanisms based on negative feedbacks are named 'ultrastability' in Kauffman's approach. Kauffman following Ashby (1960) uses 'essential variable' to describe them: "In the context of Boolean networks, keeping the essential variables in bounds corresponds most simply to holding them fixed" (page 211 in (Kauffman, 1993)). Therefore, later Kauffman looks for systems with 'frozen' areas and finds them near the phase transition. In the ordered phase, frozen areas 'percolate' (i.e. connect into one space) leaving small isolated lakes of activity inside which leads to 'homeostatic stability'. In the chaotic phase there are isolated islands of frozen areas. As can be seen in Fig. 3 (state of $T = a, b, c$), to model the regulation (mechanism of stability) using negative feedbacks, all variables (including essential ones) must be flexible. They cannot be 'frozen' because it is only a substitute for the regulations by their effects ($T = b$).

Kauffman uses the term 'homeostatic stability' for the general resistance of the system to disturbance. This resistance refers mainly to stability which emerges spontaneously together with spontaneous order. Due to practical rejection of ultrastability from this research (more in (Gecow, 2010)), homeostatic stability contains the only aspect of spontaneous resistance to disturbance which in effect leads to overestimation of spontaneous order.

The ordered area and its near vicinity, where maximum spontaneous order occurs, also exhibit the highest 'structural stability'. This is useful for adaptive evolution and 'homeostatic stability' which should be an effect of evolution. The maximum of spontaneous order is one of the most important features of this area. For Boolean networks (with equal probability of signal versions) it is the case of $K = 2$: "If the stability of each state cycle attractor is probed by transient reversing of the activity of each element in each state of the state cycle, then 80-90% of all such perturbations, the system flows back to the same state cycle. Thus state cycles are inherently stable to most minimal transient perturbations" (Kauffman, 1993).

1.2.4 Hypothesis of 'life on the edge of chaos'

Evolution using random walk in the space of network parameters should lean towards this ordered area because changes are smaller there; the system is more stable and the effects of evolution may be larger. This expectation is known as 'life on the edge of chaos'. Kauffman even expects living systems in solid regime in his "bold hypothesis: Living systems exist in solid regime near the edge of chaos, and natural selection achieves and sustains such a poised state" - page 232 in (Kauffman, 1993). I question the use of 'natural selection' as a typical Darwinian meaning. It needs elimination which is based on death. On the edge of chaos there is not anything which models death. Such a model of death can be found in the chaotic phase as large damage avalanche. Above Kauffman's view as useful approximation for certain purpose is correct if description is limited to live period without death possibility and Darwinian mechanisms. However, in such a case natural selection (working outside) cannot 'achieve' but only 'sustain' the state which is connected to reproduction ability.

A large change; large damage avalanche in chaotic systems, is obviously taken as improbable in adaptive evolution but the conclusion that adaptive evolution is improbable in chaotic systems would be too hasty. As noted above (in the description of the liquid region) in chaotic systems, small change only typically causes large effective change. Small effective changes can also take place. They may be used by adaptive evolution. It happens more frequently if parameters of a network are nearer the phase transition between order and chaos. This possibility is discussed in Ch.2.3 in Fig.6 as degrees of order r and chaos c ($r + c = 1$) of

different particular networks and it is one of more important themes of this paper. See also Fig.7 for $sf_{3,4}$ in the middle on the right (typical case) where left peak of $P(d|N)$ of very small damage is present for chaotic systems. This peak contains initiation cases which in effect manifest 'ordered' behaviour and can be used for adaptive evolution. Small networks where $N = 50$, behave like at the edge of chaos and order. This dependency remains as the left peak for larger N . Its distribution is near power law, like for the avalanches in the pile of sand which Per Bak's self-organized criticality (Bak, 1996) controls. But living systems have a method against such control - it is self-multiplying. In effect, some systems usually avoid large avalanche which for living systems means death, i.e. elimination. It cannot be a new evolutionary change (compare to (Farmer et al., 1986)). It is much more than even Lysenko proposed. Can you imagine that more than half (see Fig.5) of all the mechanisms of living organism have been changed and the organism survived? Replication allows living systems to grow (in N meaning) and this way they enter chaotic regime and can stay there. Above r (degree of order in Fig.6) is a fraction of all initiation cases which contain cases building the left peak (of very small effective changes). The right peak contains cases of chaotic behaviour which must be eliminated during adaptive evolution by Darwinian elimination; they model death. This death is necessary for typical natural selection but in an ordered regime it is absent. (Theoretically Darwinian mechanism can work without death, but for this infinite capacities of environment are necessary.)

1.2.5 Kauffman's model of gene regulatory network and its comparison to real life

The model of gene regulatory network was proposed by Kauffman (1969; 1971), it is based on the Kauffman (Boolean) network. Boolean states of gene are interpreted as active or inactive. All general expectations for the Boolean network described above concern this gene regulatory network, including the nearest of chaos-order phase transition as an effect of evolution.

Hughes et al. (2000) in real genome of *Saccaromices cerevisiae* containing $N = 6312$ genes, knocked out 227 genes, one at a time and they measured the effects of such disturbance. Next, the authors of Refs. (Rämö et al., 2006; Serra et al., 2004; 2007; Wagner, 2001) compared obtained stability to theoretical stability for different parameters. They conclude that similar stability appears for the Boolean network with fixed $K=2$, i.e. really near phase transition. Shmulevich et al. (2005) compare the amount of information stored in the time sequence of gene expression of HeLa cells with the results of simulated RBNs and they conclude that eukaryotic cells are dynamically ordered or critical but not chaotic. These results are taken as an experimental base for the 'life on the edge of chaos' hypothesis.

Nevertheless, I dispute the interpretation of this result. First of all in both these experiments data are captured from practically living cells. Theoretical homeostatic stability underestimates ultrastability as its part, i.e. regulators based on negative feedbacks which are the base of stability for living systems. Ultrastability is commonly observed as an extremely high concentration of negative feedbacks in living systems which is even used for a life definition (Korzeniewski, 2001; 2005) as its specific property. Creation of these mechanisms is an effect of Darwinian selection (in which death, as mentioned above is needed; large avalanche of damage models this death). Because cells are alive, homeostasis was not broken and stability was kept. This means there was no large avalanche, i.e. death. But it does not mean that such large avalanche cannot appear and such cells are immortal. It is obvious true that living systems behave like ordered systems and it is expected result that description of these behaviours is similar to ordered systems build randomly. It is interesting result

that similarity is so deep. But it does not imply that source of such stability is similar. In Kauffman's approach negative feedbacks are considered only on a random normal average level of appearance without any preferences. This is a very large simplification (Gecow, 2010) leading to a non-realistic modelling of stability causes of living systems. Obtained similarity has, however, simple explanation given by Kauffman - it is mentioned above simplification of ultrastability using fixed (frozen) essential variable. This move rejects out of consideration right source of stability together with its cause - Darwinian elimination but remains their effect. This is why, 'homeostatic stability' based on 'spontaneous order', i.e. typically 'structural stability', is taken as an explanation of stability of gene regulatory network (Kauffman, 1971; Rämö et al., 2006; Serra et al., 2004; 2007; Wagner, 2001) instead of the neglected homeostasis based on negative feedbacks which realize the regulation. This is the above mentioned (Ch.1.2.3) overestimation of spontaneous order.

Homeostasis built by Darwinian selection leads to stability for a certain set of initial changes. Such changes may randomly occur but they are 'known' to the system, i.e. the system reacts to them in a non-random way. E.g. small defects in DNA copying are 'known' and a certain set of repair or other safety mechanisms are prepared. The remaining changes can be treated as 'fully random'. When these changes occur, the system can behave in a chaotic or ordered way. The investigation should be focused on this set of 'fully random' changes but with stability of system in mind, it is important not to neglect 'known' changes. Current living things 'know' most of the typical changes and therefore exhibit high stability. This is true even though for fully random (unknown) changes these living systems are chaotic. Life is a continuous maintenance of equilibrium at a high level, which is a semi-unstable equilibrium - it will collapse into a large damage avalanche after a single false move. This view correctly describes a chaotic state but not an ordered one. Therefore, observed stability cannot be spontaneous, but it must be carefully collected. Only Darwinian selection can find observed stability and not in the form suggested by Kauffman (place near the ordered phase) but in the form of active regulation which are usually negative feedbacks. Kauffman, and I, do not model these homeostatic answers (based typically on negative feedbacks) which are effects of 'known type initialisations' of the system. This large simplification, however, must be taken into consideration when stability of living systems is discussed.

Currently Kauffman's model of the gene regulatory network is taken as 'early' and more attention is given to the GRN based on the Banzhaf model (Banzhaf, 2003; Knabe et al., 2006). Also 2 signal variants are taken as too strong a simplification. Nonetheless, Kauffman's model was a first approximation needed to open the way for more exact models.

1.3 Networks variants

1.3.1 Currently investigated network types in the range RBN

Kauffman (1969) introduced Boolean networks. For statistical investigation, a method of a random creation of such a network was needed. That time the obvious candidate was Erdős-Rényi pattern (Erdős & Rényi, 1960) where, for given node number N connections are chosen randomly. The number of inputs K was usually fixed and the above rule considers outputs k . This type of network was named 'Random Boolean Network' (RBN).

Barabási et al. (1999) have discovered the famous, scale free network and its importance, therefore it is known as the BA (Barabási-Albert) network. It is constructed using 'preferential attachment', i.e. new added node links to a node in the current network with a probability proportional to its node degree k . BA networks typically are not directed and k is a number of all the links of the node. Using this formula for Boolean networks it is necessary to separately

consider the number of inputs K and outputs k . Usually an easier fixed K was used (see Ch.1.1) but currently both of them are often flexible. The dynamics of Boolean networks with scale free topology were studied e.g. by Aldana (2003), Kauffman et al. (2004), Serra et al. (2004a) and Iguchi et al. (2007). They named the network SFRBN (Scale-Free RBN). Iguchi et al. (2007) also used for comparison 'directed Exponential-Fluctuation networks EFRBN' known also as a 'single scale' network where new node links to node in current network with equal probability. The old Classic RBN which Serra et al. (2004a) proposed to rename to CRBN is also used for comparison. All of these network types differ in $P(k)$ - distribution of node degree: CRBN has Poisson distribution without hubs (nodes with extremely high node degree k), $P(k)$ of SFRBN is a straight line in log-log diagram and contains many hubs, EFRBN gives a straight line in the log diagram and contain less hubs.

Most authors stay with Boolean networks due to 'life on the edge of chaos' idea. For this reason, they investigate the point of phase transition between order and chaos. There are lots of different attempts to introduce a new type of Boolean network. E.g. in opposition to the deterministic case Shmulevich et al. (2002) introduced the Probabilistic Boolean Network (PBN). The PBN is used to model gene regulatory network where transition rules are considered as random variables. Such an idea in a slightly different form appears in "a Dynamical Boolean Network (DBN), which is a Virtual Boolean Network (VBN) In this network, the set of nodes is fixed but the transition matrix can change from one time step to another" (Ito, 2008).

1.3.2 Extension of the Kauffman networks over Boolean networks - RNS, RWN and my RSN

Applying the Boolean networks to describe living things, e.g. for gene regulatory network, suggests that only two signal variants is a large simplifications - a first approximation only, and more variants should be used. I will come back to this problem later in Ch.2. As second approximation Luque & Solé (1997) introduced RNS (Random Network with multiple States) (Sole et al., 2000). In RNS, in order to reach edge of chaos a bias p is used for one signal variant making it different from the other signal variants. Later Luque & Ballesteros (2004) introduced another construction - RWN (Random Walk Network) (Ballesteros & Luque, 2005) which contains memory in its nodes' states. Functions of node perform a shift of node state which resemble differential regulations. This shifting reaches upper or lower boundaries and the result is random but in a complicated way. Construction of RWN also is an effect of the assumption that point of phase transition is important.

To these two ideas I add (Gecow, 2010) another one, but now I await living systems in chaotic regime, so the point of phase transition is not so important. My network allows for more than two equally probable variants of signal values which is an exclusive alternative based on the interpretation to bias p . I introduce s - number of equally probable variants of signal values. I call (Gecow, 2010) such a network 'Random Signal Network' (RSN). (The full name: 'Random equally probable Signal variants Network' is too long.) Note, using parameter s in the range of RSN we know that these s variants are equally probable and in range $s \geq 2$. In the Boolean network there are only two variants e.g. 1 and 0 but they must not to be equally probable.

RSN, together with known RNS and RWN, expand the notion of the 'Kauffman network'. Up till now 'the Kauffman-' and 'the Boolean network' were synonymous, but they should not be anymore. The term 'Boolean' must be limited to two variants of a signal but the 'Kauffman network' can and should contain more signal variants as is used in the RSN, RWN or in RNS models. One output signal taken as a state of node which is transmitted through all output links should be characteristic of the Kauffman network.

1.3.3 Network types and their rules of growth used in simulation of RSN

RSN is a directed functioning network. The main characteristic of the RSN, is that all signal value variants are equally probable and s ; the number of these variants can be more than two $s \geq 2$. RSN type was performed for statistical analysis (typically using simulation) of general features of networks and their dependency on different parameters like K, k, s, N and growth rules. The basic formula of RSN emerged from an important overlooked cause of probability difference in Boolean's two signals (Ch.2.1.2) described using bias p . Such a description leads to wrong results in this case. So, RSN becomes the exclusive alternative to bias p .

RSN term contains the Kauffman networks with two, and more than two equally probable signal variants. RSN also contains 'aggregates of automata' which I have introduced in (Gecow, 1975; Gecow & Hoffman, 1983; Gecow et al., 2005; Gecow, 2005a; 2008), with the same range of signals and which are not the Kauffman networks as they are defined above. The aggregate of automata has as a state of a node a k -dimensional vector of independent output signals transmitted each by another output link. It also has fixed $K = k$ for all nodes of network. This type of network has a secondary meaning - some simple examples (like lw and lx networks, Ch.3.3) do not simply work in the Kauffman mode; the coefficient of damage propagation has for aggregate of automata simple intuitive meaning (Ch.2.2.1). I have made the first investigation of structural tendencies using such simple network parameters and they gave strong effects. For the Kauffman networks this effect is weaker and comparison to aggregate of automata with the same parameters can indicate causes of observed effects.

Structural tendencies are the main goal of my approach. They model regularities of ontogeny evolution observed in classical evolutionary biology such as Weismann's 'terminal additions', Naef's 'terminal modifications' or the most controversial - Haeckel's recapitulation. These tendencies are also typically detected in any complex human activity like computer programming, technical projects or maintenance. Knowledge of their rules should give important prediction. Structural tendencies, however, occur in complex systems, but the term 'complex' is wide and vague with a lot of different meanings. Complexity needed for structural tendencies is connected to the chaos phenomena, therefore when investigating their mechanisms, chaotic systems should be well known. I investigate them using simulation of different network types in the range of RSN. In this article, simulation of ten network types will be discussed. For such a number of network types short names and a system for arranging them are needed. Therefore, I do not repeat in each name 'RSN', but I use two letters for network type name. In the Figures where there is limited space, I use only one second letter.

The general type of aggregate of automata is indicated as aa , its versions without feedbacks: general - an , extremely ordered in levels of fixed node number - lw and lx .

Similar to aa network but following Kauffman's rule (one output signal but fixed $K = k$) is named ak . For the old classical Erdős & Rényi (1960) pattern used in RBN (CRBN) 'er' is used. Note, in range of RSN it must not be a Boolean network. For scale-free network (BA - Barabási-Albert (Barabási et al., 1999; 2003)) I use 'sf'. It corresponds to SFRBN. Single-scale (Albert & Barabási, 2002) corresponding to EFRBN, I denote as 'ss'. For all simulated networks I use fixed K which in addition differentiate these two types from SFRBN and EFRBN.

The main structural tendencies need removing of nodes; only addition is insufficient. But for sf and ss network types removing includes a significant new feature of the network - it generates $k = 0$ for some nodes. Such networks are different than the typical sf and ss because removals change node degree distribution. Therefore networks built with a 30% of removals of nodes and 70% of additions get other names - sh for modified sf and si for ss with removals. In simulations of structural tendencies Gecow (2008; 2009a) I use parameter of

removal participation instead. A problem of significant change of distribution of node degree emerges which leads to some modification of growth pattern of *sf* network in different ways (Gecow, 2009b) with different network names - *se* and *sg*. As can be seen, a network type should be treated as parameter with a lot of particular values (denoted by two-letter name). This parameter covers different other parameters used sporadically in different options. Damage investigation in dependency on network size N has two stages: construction of the network and damage investigation in the constant network. Construction of the network depends on the chosen network type. Except the type '*er*', all networks have a rule of growth. Aggregate of automata '*aa*' and Kauffman network '*ak*' need to draw K links in order to add a new node (links g and h for $K = 2$ in Fig.2 on the left). These links are broken and their beginning parts become inputs to the new node and their ending parts become its outputs. For all types whose name starts with '*s*' (*sf*, *sh*, *ss* and *si* denoted later as *s?*) we draw first one link (g in Fig.2 on the right) and we break it like for: *aa* and *ak* to define one output and input. For *sf* and *sh* types at least one such output is necessary to participate in further network growth. Later, the remaining inputs are drawn according to the rules described above: for *ss* and *si* by directly drawing the node (B in Fig.2 on the right); for *sf* and *sh* by drawing a link (h in Fig.2 on the right) and using its source node (B in Fig.2 on the right).

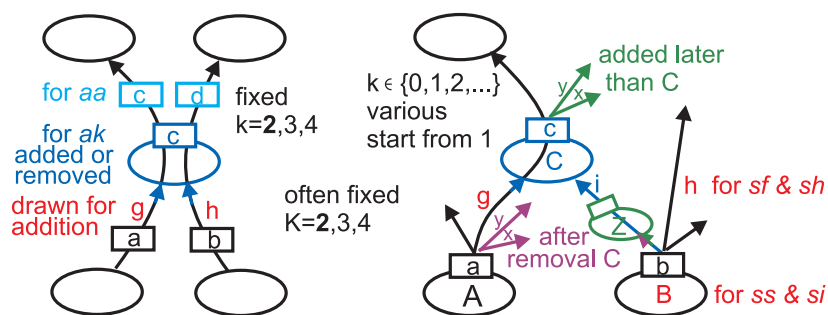

Fig. 2. Changeability patterns for *aa* and *ak* (left), *sh*, *sf*, *si* and *ss* network (right) depicted for $K = 2$. For addition of a new node to the network, links g and h are drawn. Node B is drawn instead of link h for *ss* and *si*. For $K > 2$ additional inputs are constructed like the ones on the right. The *ak* network is maintained as *aa* but there is only one, common output signal c . For removal of node, only a drawing of the node to remove is needed. Main moves are the same as for addition, but in an opposite sequence, however, for *s?*, events which occur after the addition change the situation. Removal can create $k = 0$: node Z added on link i can remain a $k = 0$ node while removing node C because part of link i from Z to removed C disappears. The outgoing links x, y , which were added to C after adding this node to the network, are moved to node A where link g starts. This lack of symmetry causes changes in distributions $P(k)$ and other features of a network. For this reason, networks *sf* and *ss* with removals of node are different than without removal of node and are named *sh* and *si* respectively.

Random removal of a node needs to draw a node only. Each node should have equal probability to be chosen. The pattern of node disconnection should be the same but in the opposite direction to connection while adding. However, if removing happens not directly after addition, the situation can change and such a simple assumption will be insufficient. Such a case appears for *s?* networks when k of the removed node can be ($k > 1$, x, y links in Fig.2 right) different than just after addition ($k = 1$) and interestingly, when on the right input link a new node (Z in Fig.2 right) was added. During the removal (of C node), this new (Z) node loses its output link and may become a $k = 0$ node. Nodes with $k = 0$ and other nodes connected to them, which have not further way for their output signals (e.g. to external

outputs) are called 'blind' nodes. The existence of 'blind' nodes in the network is one of the biggest and the most interesting problems especially for the modelling of adaptation. The importance and complexity of this problem is similar to the problem of feedbacks.

1.3.4 Connection to environment: L damaged of m outputs

Following ref. (Kauffman, 1993) the size of damage $d \in \langle 0, 1 \rangle$ is measured as the fraction of nodes with damaged output state in the all nodes of system. Serra et al. (2004) measure size of damage in number of damaged nodes and call such parameter the 'Avalanche', see Fig.7. However, this parameter is usually hard to observe for real systems (Hughes et al. (2000) done it, see Ch.1.2.5). The adaptation process concerns interactions between the system and its environment. If such a process is to be described, then damage should be observed outside the system, on its external outputs. However, network with outputs is no longer an autonomous network like the ones considered from Ref. (Kauffman, 1969) up to (Iguchi et al., 2007) and (Serra et al., 2010). Some links are special as they are connected to environment. Environment is another, special 'node' which does not transmit damage (in the first approximation), unlike all the remaining ones. Damage fades out on the outputs like on a node with $k = 0$. This is why the dynamics of damage d should be a little bit different depending on the proportion of output size m and network size N (compare *sf* 3,4 in Fig7). Environment as an objectively special node can be used for the indication of the nodes' place in a network, which without such special node generally have no objective point of reference. The main task of this special node in the adaptation process is a fitness calculation and Darwinian elimination of some network changes.

The simplest definition of damage size on system outputs is: the number L of damaged output signals. For large networks with feedbacks it is applicable using only a simplified algorithm described in Ch.3.1, and e.g. Ref. (Gecow, 2010). It omits the problem of circular attractors. Formally, L is a Hamming distance of system output signal vectors between a control system and a damaged one. Practically, using my algorithm, it is the distance between system output before and after damage simulation. For simulations, the system has a fixed number $m = 64$ of output signals which means that $L \in \langle 0, m \rangle$. We can expect, that distributions $P(d)$ and $P(L)$ will be similar. In fact, asymptotic values (for 'matured systems'): dmx of d and Lmx of L are simply connected: $dmx = Lmx/m$. But such a connection is not true for smaller systems and L is smaller than expected. Note, that the number of output signals m is constant and much smaller than the growing number N of nodes in the network, which must influence the statistical parameters and their precision.

2. RSN - More of equally probable signal variants as alternative to bias p

RSN is not a version of a known network type or a second approximation describing the same phenomena. Although RSN can be formally treated as a version of RNS (see Ch.1.3.2) with bias p equal to the probability of the remaining signal variants. It is an important, overlooked, simple and basic case of described reality, competitive to bias p and to the not so simple RWN formula. As will be shown, RSN leads to different results than when using bias p . Bias p has been used for all cases up till now.

2.1 Why more equally probable signal variants should be considered

2.1.1 Boolean networks are not generally adequate

It is commonly assumed, that Boolean networks are always adequate in any case. A simple example (Fig.3) shows that this is false and it leads to wrong effects, especially for statistical

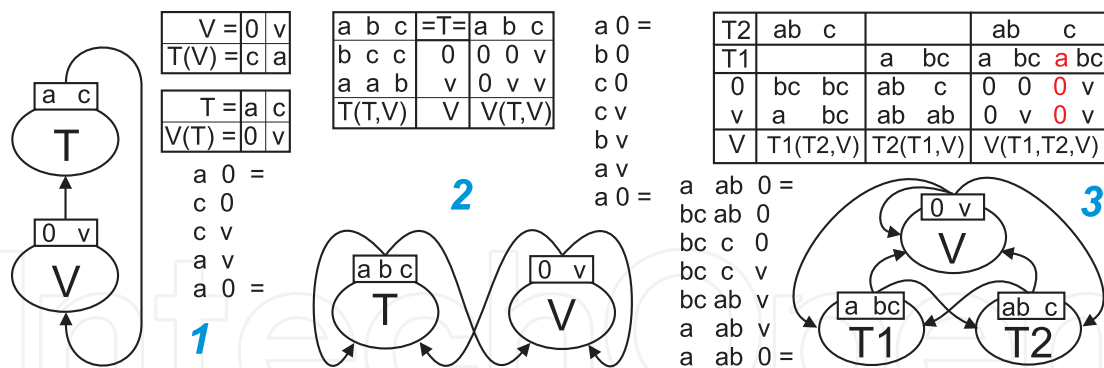

Fig. 3. Thermostat of fridge described using Kauffman networks as an example of regulation based on negative feedbacks and the inadequateness of the Boolean networks. Case (2) describes thermostat just as it is in reality - temperature T is split into three sections a - too cold, b - accurate, c - too hot, but this case is not then Boolean. To hold signal in Boolean range we can neglect temperature state b - case (1) or split node T into two nodes with separate states - case (3) which together describe all temperature states, but using this way a dummy variant ($a + c$) of temperature state is introduced. Node V decides power for aggregate: v - on, 0 - off. Tables of functions for nodes and for consecutive system states are attached.

expectation. Normally, more than two signal variants are needed for an adequate description. If a fridge leaves the proper temperature range b as a result of environment influence and enters too high a temperature in the range c , then power supply for the aggregate is turned on and temperature inside the fridge goes down. It passes range b and reaches the too-cold range a , then power is turned off and the temperature slowly grows through b section. Case (2) in Fig.3 this regulation mechanism is properly described in Kauffman network terms. However, there are three states of temperature a, b, c which are described by three variants of node T and therefore, this case of the Kauffman network is not a Boolean network.

To hold signal describing temperature in Boolean range (two variants only) we can neglect temperature state b . This is case (1) but here, the most important, proper temperature state, which is the state the fridge stays in most of the time, is missing. Almost any time we check the state of a real fridge this state is not present in such a description. Reading such a description we find that wrong temperature a ; meaning too cold occurs directly after wrong temperature c ; too hot and vice versa. Splitting node T into two nodes $T1$ and $T2$ with separate states - case (3) is the second method to hold Boolean signals. Two separate Boolean signals together create four variants but temperature takes only three of them. A new dummy state emerges: a - too cold and c - too hot simultaneously. It has no sense and never appears in reality but a function should be defined for such a state. In the Table, the functions values for such dummy input state are marked by red. For statistical investigation, it is taken as a real proper state. Such groundless procedure produces incorrect results.

Cases (1) and (3) describe reality inadequately. It is because Boolean networks are not generally adequate. We can describe everything we need using Boolean networks but in many cases we will introduce dummy states or we will simplify something which we do not want to simplify. In both cases the statistical investigation will be false. The only way is to use a real number of signal variants and not limit ourselves to only two Boolean alternatives.

2.1.2 Two variants are often subjective

Two alternatives used in Boolean networks may be an effect of two different situations: first - there are really two alternatives and they have different or similar probabilities; and second

- there are lots of real alternatives, but we are watching one of them and all the remaining we collect into the second one (as is done for $T1$ and $T2$ in Fig.3). If in this second case, all of real alternatives have similar probability, then the watched one has this small probability which is usually described using bias p . The collection of the remaining ones then, have large probability. Characteristically, the watched alternative event is 'the important event' as far as systems which adapt are concerned. Note 1: such adapting systems are normally investigated. Note 2: for system which adapt, the notions: 'important', 'proper' and 'correct' are defined using fitness but it has nothing to do with the statistical mechanism and such simplification remains subjective. This is the main, yet simple and important cause of introducing more than two alternatives. It is used to be objective and obtain adequate results

If the long process leading from gene mutations to certain properties assessed directly using fitness has to be described, then more than two signal alternatives seem much more adequate. It should be remarked that there are 4 nucleotides, 20 amino acids (similarly probable in the first approximation) and other unclear spectra of similarly probable alternatives. In this set of the spectra of alternatives, the case of as few as two alternatives seems to be an exception, however, for gene regulatory network it seems to be adequate in the first approximation (active or inactive gene). Investigators of real gene networks suggest: "While the segment polarity gene network was successfully modelled by a simple synchronous binary Boolean model, other networks might require more detailed models incorporating asynchronous updating and/or multi-level variables (especially relevant for systems incorporating long-range diffusion)." (Albert & Othmer, 2003) In second approximations which are RNS (Luque & Solé, 1997; Sole et al., 2000) and RWN (Ballesteros & Luque, 2005; Luque & Ballesteros, 2004), more than two variants are used but in a different way than here (RSN).

2.1.3 Equal probability of signal variants as typical approximation

For a first approximation using equal probability of alternatives from the set of possibilities is a typical method and a simplification necessary for prediction and calculation. In this way we obtain s (which can be more than two) equally probable signal variants ($s \geq 2$) (Gecow, 1975; Gecow & Hoffman, 1983; Gecow et al., 2005; Gecow, 2008; 2010). This is a similar simplification as collections of remaining alternatives to one signal variant, but seems to be less different to the usually described real cases.

2.2 Differences of results for descriptions using bias p and $s \geq 2$

At this point an important example should be shown which leads to very different results for the above two basic variants of description - the old using bias p and my new using s . I do not suggest that using bias p is always an incorrect description but that for the meaning part of the cases it is a very wrong simplification and other ones with $s > 2$ should be used.

2.2.1 w^t describes the first critical period of damage spreading and simply shows that case $s = 2$ is extreme

Returning to coefficient of damage propagation introduced in Ch.1.2.2 I now define it using s and K . This is $w = \langle k \rangle (s - 1) / s$. It can be treated as damage multiplication coefficient on one element of system if only one input signal is changed. w indicates how many output signals of a node will be changed on the average (for the random function used by nodes to calculate outputs from the inputs). (I assume minimal P - internal homogeneity (Kauffman, 1993) in this whole paper and approach.) I have introduced it in Refs. (Gecow, 1975; Gecow & Hoffman,

1983; Gecow, 2005a) as a simple intuitive indicator of the ability of damage to explode (rate of change propagation) which can be treated as a chaos-order indicator.

Coefficient w is interesting for the whole network or for part of the network, not for a single particular node. However, it is easier to discuss it on a single, average node. Therefore I have started my approach using aggregate of automata (Gecow, 1975; Gecow & Hoffman, 1983; Gecow et al., 2005) (Ch.1.3.3 - aa, Fig.2) where $K = k$ and each outgoing link of node has its own signal. It differs to Kauffman network where all outgoing links transmit the same signal. In this paper I consider networks with fixed K and $\langle k \rangle = K$, i.e. all nodes in the particular network have the same number of inputs. If so, I can write $w = K(s - 1)/s$.

If $w > 1$ then the damage should statistically grow and spread onto a large part of a system. It is similar to the coefficient of neutron multiplication in a nuclear chain reaction. It is less than one in a nuclear power station, for values greater than one an atomic bomb explodes. Note that $w = 1$ appears only if $K = 2$ and $s = 2$. Both these parameters appear here in their smallest, extreme values. The case $k < 2$ is sensible for a particular node but not as an average in a whole, typical, randomly built network, however, it is possible to find the case $K = 1$ in Fig.3.1 and Fig.4 or in Refs. (Iguchi et al., 2007; Kauffman, 1993; Wagner, 2001). For all other cases where $s > 2$ or $K > 2$ it is $w > 1$.

In the Ref. (Aldana et al., 2003) similar equation (6.2): $K_c(s - 1)/s = 1$ is given which is a case for the condition $w = 1$. K_c is a critical connectivity between an ordered and chaotic phase. They state: "The critical connectivity decreases monotonically when $s > 2$, approaching 1 as $s \rightarrow \infty$. The moral is that for this kind of multi-state networks to be in the ordered phase, the connectivity has to be very small, contrary to what is observed in real genetic networks." However, as I am going to show in this paper, that the assumption that such networks should be in ordered phase is false.

The critical connectivity was searched by Derrida & Pomeau (1986) and they found for bias p that $2K_c p(1 - p) = 1$. (See also (Aldana, 2003; Fronczak et al., 2008). Shmulevich et al. (2005) use 'expected network sensitivity' defined as $2Kp(1 - p)$ which Rämö et al. (2006) call the 'order parameter'. Serra et al. (2007) use (4.9) $\langle k \rangle q$ where q is the probability that node change its state if one of its inputs is changed. This value "coincides with 'Derrida exponent' which has been often used to characterize the dynamics of RBN".) The meaning of these equations is similar to that above (6.2) equation in the (Aldana et al., 2003). See Fig. 4. But putting $p = 1/s$ it takes the form: $2K_c(s - 1)/s^2 = 1$ which only for $s = 2$ is the same as above.

For coefficient w it is assumed that only one input signal is damaged. This assumption is valid in a large network, only at the beginning of damage spreading. But this period is crucial for the choice: a small initiation either converts into a large avalanche or it does not - damage fades out at the beginning. In this period each time step damage is multiplied by w and if $w > 1$, then it grows quickly. When damage becomes so large that probability of more than one damaged input signal is meaning, then already the choice of large avalanche was done (i.e. early fade out of damage is practically impossible). See Fig. 5. in Ch 2.2.3.

2.2.2 Area of order

For $s \geq 2$ (and $K \geq 2$) damage should statistically always grow if it does not fade out at the beginning when fluctuations work on a small number of damaged signals, and whenever it has room to grow. That damage should statistically always grow is shown in my 'coefficient of damage propagation', and chaos should always be obtained. Only case $s = 2, K = 2$ is an exception. However, (see Fig. 4) if we take a particular case with larger s (e.g. 6) and small $K > 2$ (e.g. $K = 3$), and we use the old description based on bias p , then we obtain an extreme

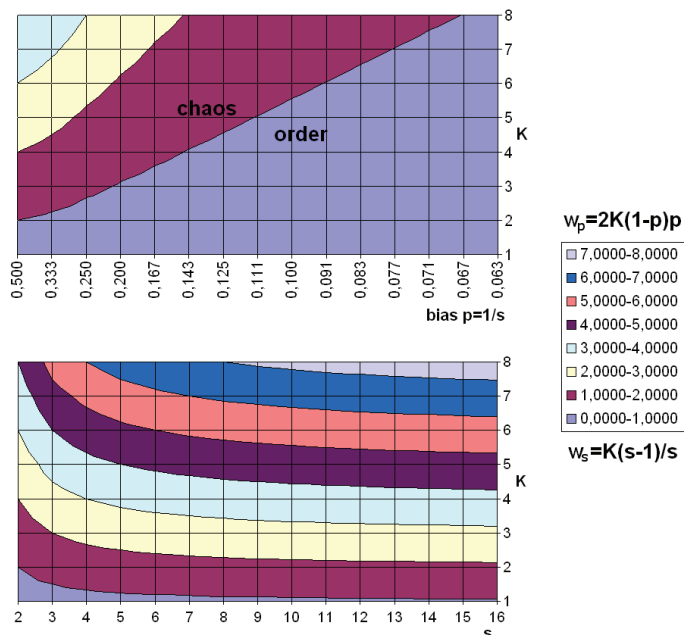

Fig. 4. Values of coefficient of damage propagation w_s for s and K and phase transition between order and chaos also for bias p . If the case where s equally probable variants is described using the bias p method ($s - 1$ variants as the second Boolean signal variant), then instead the lower diagram, the upper one is used, but it is very different.

bias $p = 1/6$ for which order is expected (upper diagram in Fig. 4). In the lower diagram the coefficient w is shown for description case with all signal variants, but for simplicity they are taken as equally probable. These two dependences are very different, but for $s = 2$ they give identical predictions. This means, that we cannot substitute more than two similarly probable signal variants for an ‘interesting’ one and all remaining as a second one and use ‘bias p description’, because it leads to an incorrect conclusion.

In RNS signal variants are not equally probable. In RNS bias p plays an important role allowing investigation of phase transition to chaos as in the whole Kauffman approach. It is not a mechanism which substitutes bias p , although using $p = 1/s$ the RNS formally contains my RSN. Typically the case of more than two variants which is taken as interpretatively better (Aldana et al., 2003), is rejected (Aldana et al., 2003) (see above Ch.2.2.1) or not developed as contradictory with the expectation of ‘life at the edge of chaos’ which I question here.

2.2.3 Damage equilibrium levels for $s > 2$ are significantly higher

Dependences of new damage size on current damage size after the one synchronous time step depicted in Fig. 5 on the right, are calculated in a theoretical way based on annealed approximation (Derrida & Pomeau, 1986) described in Kauffman (1993) book (p.199 and Fig.5.8 for $s = 2$). Such a diagram is known as ‘Derrida plot’, here it is expanded to case $s > 2$ and for aa - aggregate of automata.

If a denotes a part of damaged system B with the same states of nodes as an undisturbed system A , then a^K is the probability that the node has all its K inputs with the same signals in both systems. Such nodes will have the same state in the next time point $t + 1$. The remaining $1 - a^K$ part of nodes will have a random state, which will be the same as in system A with probability $1/s$. The part of system B which does not differ with A in $t + 1$ is therefore

$a^K + (1 - a^K)/s$. It is the same as for RNS (Sole et al., 2000). The damage $d = 1 - a$. For $K = 2$ we obtain $d_2 = wd_1 - wd_1^2/2$ where for small d_1 we can neglect the second element. For aggregate of automata (aa) if $K = 2$ then $d_2 = d_1 * w - d_1^2 * (s - 1)^2 / (s + 1) / s$ which is obtained in a similar way as the above. Here also for small d_1 we can neglect element with d_1^2 which allows us to use simple w^t for the first crucial period of damage spreading.

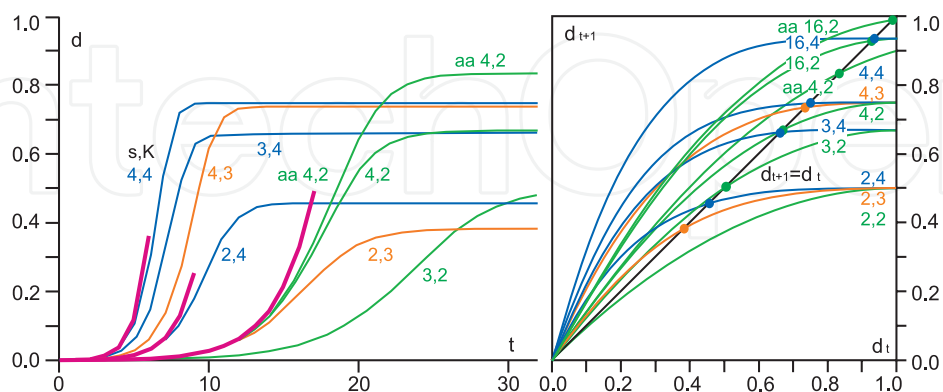

Fig. 5. Theoretical damage spreading calculated using an annealed approximation. On the right - damage change at one time step in synchronous calculation known as the 'Derrida plot', extended for the case $s > 2$ and for aa network type. The crossing of curves $d_{t+1}(d_t, s, K)$ with line $d_{t+1} = d_t$ shows equilibrium levels dmx up to which damage can grow. Case $s, K = 2, 2$ has a damage equilibrium level in $d = 0$. These levels are reached on the left which shows damage size in time dependency. For $s > 2$ they are significantly higher than for Boolean networks and for aa than for the Kauffman network. All cases with the same K have the same colour to show s influence. A simplified expectation $d(t) = d_0 w^t$ using coefficient w is shown (three short curves to the left of the longer reaching equilibrium). This approximation is good for the first critical period when d is still small.

These figures show that the level of damage equilibrium for aggregate of automata is much higher than for the Kauffman networks. To expect $a_{aa,t+1}$ - the part of the nodes in aa network which does not differ at $t + 1$ in systems A and B , we can use expectation for the Kauffman networks shown above. Such $a_{Kauff,t+1}$ describes signals on links of aa, not the node states of aa network which contain K signals: $a_{aa,t+1} = a_{Kauff,t}^K + (1 - a_{Kauff,t}^K) / s^K$

2.3 Importance of parameter s from simulation

The results of simulations show other important influences of parameter s , especially for its lower values, on the behaviour of different network types. The annealed approximation does not see those phenomena. It is shown in Fig.6. However, to understand this result I should first describe model and its interpretation. The puzzles of such a complex view of a complex system are not a linear chain but, as a described system, a non-linear network with a lot of feedbacks resembling tautology. Therefore, some credit for a later explanation is needed. For now it can build helpful intuition for a later description.

To describe Fig.6 I must start from Fig.7 which is later discussed in detail. Now, please focus on the right distributions in first row of Fig.7. It is $P(d|N)$ for autonomous sf network type with $s, K = 3, 4$. It is the usual view of damage size distribution when a network grows, here from $N = 50$ to $N = 4000$. What is important? - That for larger N there are two peaks and a deep pass between them, which reaches zero frequency (blue bye) and therefore clearly separates events belonging to particular peaks. These two peaks have different interpretations. The

right peak, under which there is a black line, contains cases of large avalanches which reach equilibrium level (as annealed model expects) and never fade out. Size of damage can be understood as the effect of its measure in lots of particular points during its fluctuation around equilibrium level. It is chaotic behaviour. The left peak is depicted on the left in A - number of damaged nodes, i.e. 'Avalanche' (Serra et al., 2004), because in this parameter it is approximately constant. It contains cases of damage initiation after which damage spreading really fades out. But because initiation is a permanent change (in interpretation, see Ch.3.1), a certain set of damaged nodes remains and this is a damage size, which is small. This is an ordered behaviour. Autonomous case was investigated in simulation described in Fig.6 and by the Kauffman approach. In Fig.6 the fractions of ordered (r) and chaotic (c) cases are depicted. Together, they are all cases of damage initiation ($r + c = 1$). Parameters r and c have an important interpretation: r is a 'degree of order', and c is a degree of chaos of a network. Real fadeout described by r only occurs in a random way which does not consider negative feedbacks collected by adaptive evolution of living systems. Assuming essential variable fixed we can move effects of negative feedbacks into left peak and add them into r .

For comparison I choose five cases described as s, K : 2,3; 2,4; 3,2; 4,2; 4,3 for the five network types: er, ss, sf, ak, aa . In this set there are: $K = 3$ and $K = 4$ for $s = 2$, next: $s = 3$ and $s = 4$ for $K = 2$. Similarly for $K = 3$ and $s = 4$ the second parameter has two variants. The coefficient w is the smallest for case 3,2 ($w = 1.33$) and the largest in the shown set for 4,3 ($w = 2.25$). Cases 2,3 and 4,2 have the same $w = 1.5$ and for er they have the same value r .

Each simulation consists of 600 000 damage initiations in 100 different networks which grow randomly up to a particular N . After that each node output state was changed 3 times (2 times). Types of fadeout (real or pseudo) were separated using threshold $d = 250/N$ where zero frequency is clear for all cases. The shown in Fig.6 results have 3 decimal digits of precision, therefore the visible differences are not statistical fluctuations. Simulations were made for $N = 2000$ and $N = 3000$ nodes in the networks but result are practically the same.

As can be seen, using higher $s = 4$ for $K = 2$ causes damage spreading to behave differently than for $s = 2$ and $K = 3$, despite the same value of coefficient $w = 1.5$, except for er network type. Therefore, both these parameters cannot substitute for each other, i.e. we cannot limit ourselves to one of them or to the coefficient w . In the Kauffman approach, chaotic regime was investigated mainly for two equally probable signal variants, i.e. $s = 2$ and different K parameter only, but dimension of s is also not trivial and different than dimension K .

The ss and ak networks exhibit symmetrical dependency in s and K but for the most interesting sf and er network types there is no symmetry (see (Gecow, 2009)). For sf the dependency on s is stronger but for er it is weaker than the dependency on K . These differences are not big but may be important. The scale-free network, due to the concentration of many links in a few hubs, has a much lower local coefficient of damage spreading w for most of its area than coefficient for the whole network. The significantly lower damage size for sf network is known (Crucitti et al., 2004; Gallos et al., 2004) as the higher tolerance of a scale-free network of attack. Also Iguchi et al. (2007) state: "It is important to note that the SFRBN is more ordered than the RBN compared with the cases with $K = \langle k \rangle$ ". The er network, however, contains blind nodes of $k = 0$ which are the main cause for the different behaviour of this network type. Networks types create directed axis used in Fig. 6 where degrees of order and chaos are monotonic except $K = 2$ for er .

Ending agitation for $s \geq 2$ I would like to warn that the assumption of two variants is also used in a wide range of similar models e.g. cellular automata, Ising model or spin glasses (Jan & Arcangelis, 1994). It is typically applied as a safe, useful simplification which should be used

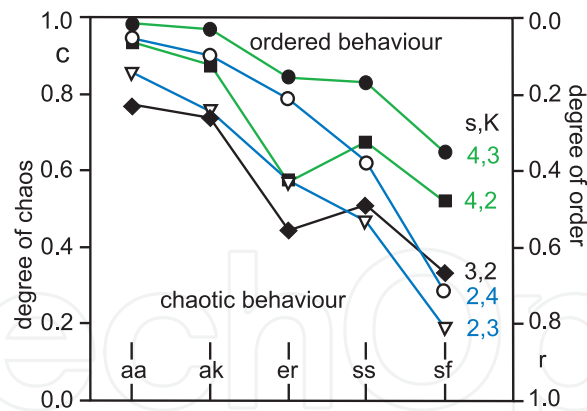

Fig. 6. Degrees of order and chaos as fractions of ordered (real fade out) and chaotic (pseudo fade out - large damage avalanche up to equilibrium level) behaviour of damage after small disturbance for five different network types and small values of parameters s and K . For $N = 2000$ and $N = 3000$ the results are practically the same. The points have 3 decimal digits of precision. Cases of parameters s and K are selected for easy comparison. Note that for $s, K = 4,2$ and $2,3$ the coefficient $w = 1.5$.

for preliminary recognition. But, just as in the case of Boolean networks, this assumption may not be so safe and should be checked carefully. In the original application of Ising model and spin glasses to physical spin it is obviously correct, but these models are nowadays applied to a wide range of problems, from social (e.g. opinion formation) to biological ones, where such an assumption is typically a simplification.

3. Emergence of matured chaos during network growth

3.1 Model of a complex system, its interpretation and algorithm

3.1.1 Tasks of the model

This model is performed to capture the mechanisms leading to the emergence of regularities of ontogeny evolution observed in old, classical evolutionary biology. For example, 'terminal addition' which means that ontogeny changes accepted by evolution typically are an addition of new transformation which takes place close to the end of ontogeny, i.e. in the form similar to adult. (Ontogeny is a process of body development from zygote to adult form.) 'Terminal modification' is a second such regularity, typically taken as competitive to first one. It states, that additions and removals of transformation are equally probable, but these changes happen much more frequently in later stages. I define such regularities as 'structural tendencies' which are the by-product of adaptive conditions during adaptive evolution of complex networks. Structural tendencies are differences between changeability distribution before and after elimination of non-adaptive changes. Structural tendencies are easily visible in human activity as well. This is wide and important theme.

This main task of a model indicates the range and scale of the modelled process. It is not a system answer for particular stimuli that will be modelled, but a statistical effect of adaptive changes of a large general functioning network over a very long time period. Maybe, mathematical methods can be implemented, but the preferred method for such a non-linear model is a computer simulation which to be real, model and algorithm must be strongly simplified. As was described in Ch.1.2 typical behaviour of network activity is looping in circular attractor. This view was developed for autonomous networks, i.e. without links from- and to the external environment. However, interaction with the environment is intensive for

living systems, crucial for adaptive evolution mechanism, and very complex. It includes two main elements which in first approximation can be separated. The first is: influence of the environment on network function which can be described using external inputs of network. The second is: elimination based on network features which can be described using external output signals of network (through define fitness). Fitness is actually an effect of a large number of events where a particular environment sends particular stimuli, and the system answers on the stimuli. In the effect of such a long conversation, large avalanche of damage in the system happens or does not happen. Many such events and similar systems, after averaging, define fitness. This whole process can be omitted using similarity of network output to arbitrary defined requirements. But this method is easy to do in simple models where such particular output exists. Even if environment is constant, circular attractors instead are expected. Constant environment may describe statistically stable environment over a long time period. In this period the stable function of a system with a particular output signal vector should be described (for the fitness definition). Evolutionary change of network structure changes network function and gives new fitness. This fitness is used to decide whether this change should be accepted or eliminated.

3.1.2 Starting model of a stably functioning system without feedbacks

To obtain such a description of stable function of system which can give correct statistical results it is easier to start from the simple case of network without feedbacks. This starting model is lack of simplifications and has simple interpretation. Later, when feedbacks will be added, some necessary simplifications, or a neglecting of the interpretational restrictions which do not change the results, will be introduced.

Let each node-state of this network equal the value of the current signals function on the node inputs. It is not a typical system state - in the next time step (e.g. in the synchronous mode) nothing will be changed. Now a disturbance which permanently changes (change remains constant) one node function is introduced and this node is calculated. To obtain a new stable state of the system function, only nodes with at least one input signal which had changed (as a result of damage) are calculated. For this calculation the old signals on the remaining inputs can be used if for a given node they do not depend on the remaining nodes waiting for calculation. Such a node will always exist because a node does not depend on itself (above it is assumed that the network is without feedbacks). After a finite number of node calculations the process of damage spreading will stop (fade out) - it reaches outputs of the network or 'blind nodes' without outputs or it simple fades out. Now all the node states are again equal to the function value of the current node inputs as was the case at the beginning. However, despite this fade out of damage spreading, lots of node states are different than at the beginning, i.e. - damaged. Only the size of damage is important here. The damaged part of the network is a clear tree which grows inside the 'cone of influence' of the first damaged node (Fig.9 Ch.3.3.1) It is necessary to emphasize that the dynamical process of damage spreading really fades out - i.e. in the next time steps there are no new nodes whose states become different than in a not disturbed system. But in effect, the nodes which function in other ways remain in the new stably functioning system because initiating change is permanent. To control damage spreading only the disturbed system and only nodes with damaged input are calculated.

This paper is limited to damage spreading; I will not use fitness and discuss adaptive evolution. For statistical investigation of damage size, particular functions do not need to be used. Therefore, it is not necessary to check a dependency, and a waiting; node in any sequence can be calculated, i.e. its new state can be drawn. In such a case, the assumption

that all node states are equal to the value of the function of the current input signal is not necessary.

3.1.3 Including feedbacks

The process of damage spreading must fade out, because there are no feedbacks, although feedbacks are usual in modelled systems and cannot be neglected. In the case of feedbacks, sometimes an already calculated node gets a damaged input signal for a second time. For measuring the statistical damage size only, it is not necessary to examine its initiation for the second time. If such a second initiation will be processed, then the process virtually never stops. In one large simulated network there are a few decades of such feedbacks with lots of common points and probability, then all of them will simultaneously fade out when coefficient $w > 1$ is very small. Therefore, damage can really fade out only in the first few steps, when the probability that the loop of feedback is reached and closes is still very small. 'Loop closes' means that some already calculated (damaged) nodes get damaged input the second time. Because the already calculated node is not calculated a second time, then damage must also fade out. But it is 'pseudo fade out' which substitutes infinite damage spreading on an equilibrium level. Obtained damage size is statistically identical to distribution of damage size checked in lots of points when damage size fluctuates around equilibrium level.

Such assumptions of model, define simple and useful algorithm described in Ref.(Gecow, 2010) which I use in my investigation. Existence of damage initiation cases with effective middle damage size is a limitation of parameters of this model. In these cases it is not clear if there is pseudo- or real fade out. In such a range of network parameters, the result may be not exact. It is more or less exact depending on fraction of the middle damage cases. This model and algorithm are therefore prepared for chaotic networks where they are exact. As was mentioned in Ch.2.3 and will be discussed below, on chaotic area the cases of real- and pseudo fade out are clearly separated in two peaks of damage size distribution.

3.2 Simulation of networks growth and damage spreading

In opposition to Kauffman's approach and simulation described above in Ch.2.3, now I examine networks with external outputs and inputs. For all simulation I assume $m = 64$ external output signals which are watched for damage and the same number of input signals which are constant. Therefore networks are not autonomous but similar. The main task of this experiment is to get a view of how chaos emerges during network growth and when it can be treated as matured. This task can be translated to obtain and analyse distributions of damage size inside different networks and on their outputs in a large range of network sizes and for other different parameters like *type, s, K*.

This theme was interesting because structural tendencies clearly occur in a range of 'complex' networks. Such complexity was connected to clear separation of right peak from the left one in damage size distribution. These dependency was observed from the beginning of the structural tendencies investigation. Similar in effects three criterion of such 'complexity' threshold are shown in (Gecow, 2008) in Table 1. I.e. 90% of dmx (equilibrium level, see Fig.5), 80% of Lmx and zero occurrence in frequency between peaks even for large statistics. These investigations, however, were a first. Much wider data are analysed in (Gecow, 2009) in Fig.10 (unfortunately, not with the latest version of the description). The upper diagrams (10.1 and 10.2) show the position of the right peak maximum in $P(d)$ distribution in dependency on N up till 4000, and the lower ones (10.3 and 10.4) analogue for $P(L)$. In the left diagrams (10.1 and 10.3) all 5 network types (*sf, ss, er, ak, aa*) are shown for $s, K = 4, 2$ but for right diagrams,

only extreme sf and ak for $s = 4, 16, 64$ with $K = 2$ and only $K = 3$ with $s = 4$. In the effect the previous suggestion of very similar results of the above three criteria has not been confirmed. Therefore, in (Gecow, 2010a) a simulation experiment investigating the whole interesting range of parameters was performed. As in Fig.7 is shown, criteria based on distance to dmx or Lmx are an effect of existence in the network special node - 'environment' and its parameter m , but it is an important element of described reality, e.g. living systems.

3.2.1 Description of the experiment

Fig.7 shows the main results of simulations: distributions $P(d|N)$ of damage size d (a fraction of all N nodes which have different state than in the non-disturbed network); and distributions $P(L|N)$ damage size of network external output signals in number of damaged signals L . Each of these distributions are shown for 20 particular points of $N = 50, 70, 100, 130, 160, 200, 240, 300, 400, 500, 600, 800, 1000, 1200, 1400, 1600, 2000, 2400, 3000, 4000$ shown in log-scale. In Fig.7, only three cases of network types and their particular parameters s and K are shown but all combinations of 7 network types ($sh, sf, si, ss, er, ak, aa$), $s = 2, 3, 4, 16$ and $K = 2, 3, 4$ except cases $s, K = 2, 2$ and $16, 4$ were simulated. This is together $7 * (4 * 3 - 2) = 70$ cases (Gecow, 2010a). As in Ref. (Gecow, 2010;a) these parameters are denoted in the form: two (or one, second only) letters of network type, followed by s and K parameters in number separated by a comma.

Networks grow during the simulation (except er which is drawn each time). At the particular levels of N damage is simulated as in Ch.2.3 where all remaining variants of state of each node are used in turn as damage initiation. When they all are used, the network grows to the next level of N . Results of a few networks with the same parameters are summarised. For each level of N the same number of events is assumed (near 300 thousands, for $s = 2, 3 - 800\ 000$), therefore for larger N less networks are sufficient. When $s=16$, then there are 15 remaining states and to obtain 300 000 events for a network containing $N=4000$ nodes it is enough to build 5 networks. As it will be shown later, it is a relatively small number and a large but interesting fluctuation was obtained (see Ch.3.2.3 and Fig.8). Distribution $P(d|N)$ has a discrete number of points, it is N . For all N in Fig.7 there are a fixed 200 points used to make comparison available, but such an operation must cause some visible discontinuities in the beginning of the first, left peak.

In Fig.7 only 3 cases are shown, but they depict all the basic phenomena well. One autonomous case is added for comparison. This is the main view of the evolution process of distribution of damage size d and L during network growth. In the details of this process a threshold of matured chaos is searched for. In the plane parallel to the paper, a distribution $P(d)$ or $P(L)$ is shown for the particular network size N . N grows depicted in logarithmic scale in depth behind the paper. For non-zero values of P (as frequency obtained as simulation results) red colour is used, for zero value - blue. The vertical lines are blue if both connected values of frequency (P) are zero and green otherwise. This useful method easily depicts the dynamics of chaos appearance as nice landscape with the important area of blue 'bay' where exact zero between peaks occurs.

The right peak (for networks with external connections) emerges from the tail of the left peak in the part of small damage (for autonomous network it appears faster and near dmx). In the first period of network growth it moves to the right, but later it turns smoothly and its position becomes stable, drawing an asymptotical line (black one) to the parallel line to the N axis. It is a vertical projection of the maximum of right peak on 'sea level' ($P = 0$). These lines from all simulation cases are collected and analysed in details in (Gecow, 2010a). In addition, the

degree of chaos c and similarity of d and L (as $L/m/d$, i.e. departure of $L = d * m$ expectation) are analysed. There are searched criteria of chaotic features where a small network effect can be neglected. The results have a short description in the next chapter. The main conclusion is that there is no critical point which can be used for such criterion. But matured chaos appears, and some threshold (but smooth and little bit different in different phenomena) objectively exist. In such a case, any particular criterion must contain arbitrary defined value.

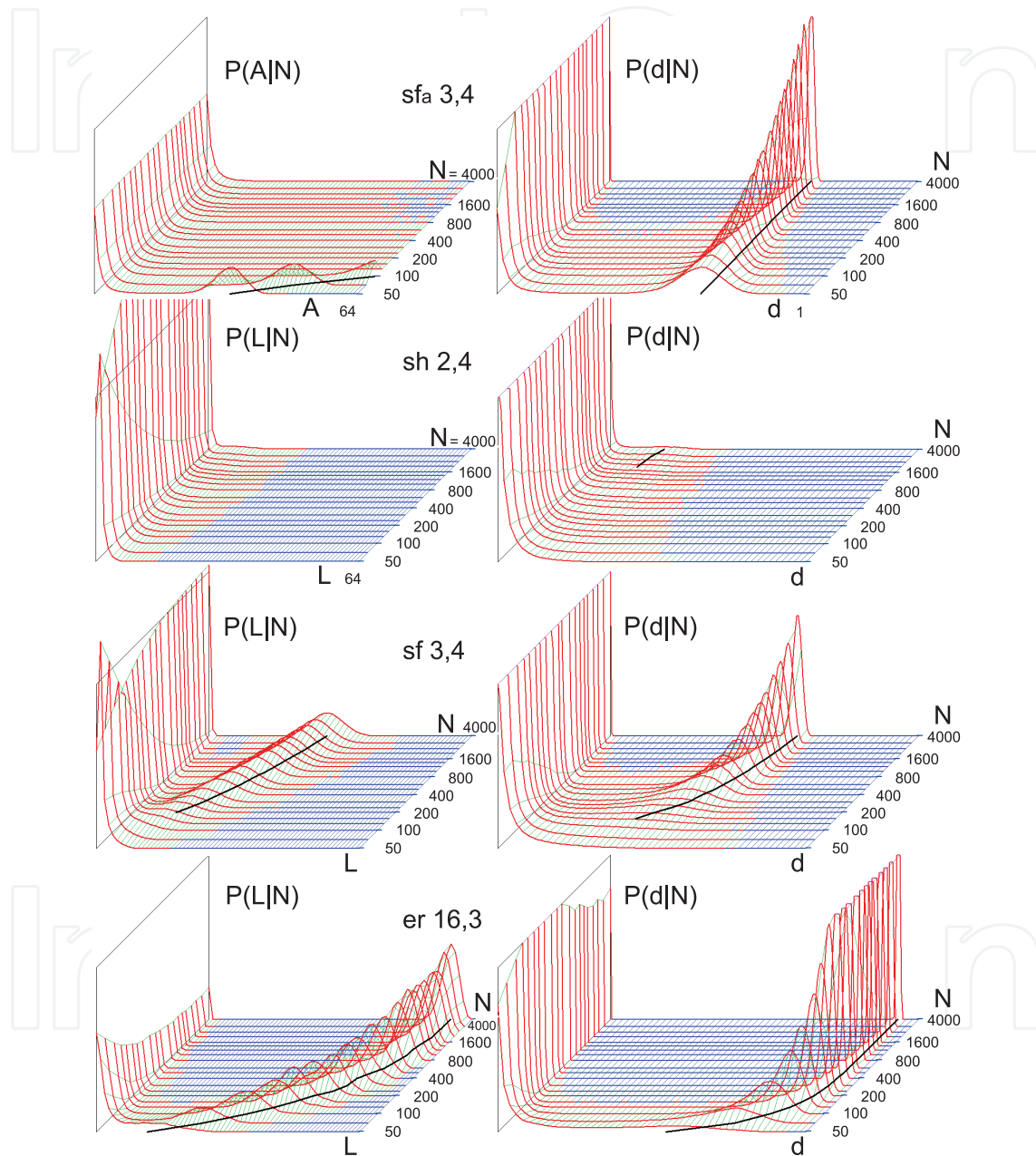

Fig. 7. Evolution of damage sizes L (left) and d (right) distributions during network growth for different *type, s, K*. In the first row autonomous case is shown, first part of left peak (left) in 'avalanche' A . 3 of 70 simulated cases show the full spectrum of main features: from the least- to the most chaotic. Blue indicates zero frequency. Vertical projection (black line) of the right peak maximum on the 'sea level' plane ($P=0$) is the equilibrium level of damage.

Small network ($N = 50$) typically behaves as it does on the edge of chaos and order (near power law as for percolation point). This dependency approximately remains as the left peak in the chaotic area and there is a place for life evolution. Length of d axis is constant for different N , those suppresses its shape for larger N even if it is the same for the number of damaged nodes (see Fig.7 'avalanche' distribution $P(A|N)$ for autonomous network). Right peak emerges where black line starts. For extremely ordered sh 2,4 (the least chaotic is sh 2,3) shown in the second row in Fig.7, right peak does not appear for $P(L|N)$ even for $N = 4000$ but for $P(d|N)$ it just starts to appear. For extremely chaotic network er 16,3 right peak is present already for $N = 50$. (The most chaotic are ak and aa 16,3.) Between peaks the pass forms whose minimum goes down and reaches zero frequency (forms the blue bay). Note, that only where this bay appears the reversed annealed algorithm used for these simulations becomes surely exact. For all sections of N up to this point, the algorithm gives only approximate results, but they sufficiently show the qualitative properties of the growth process and the emergence of the chaotic features.

3.2.2 Results

The term 'matured chaos' in the context of network size N has two main aspects, they are: 1- high level of chaos; and 2- small influence of 'finite size effects'. The first one splits itself into: a- high value of equilibrium level of damage (influence of environment can be neglected); and b - high value of degree of chaos c (Ch.2.3, Fig.6). The height of equilibrium level of damage (1.a) for the very large networks (infinite N), i.e. dmx and Lmx , are expected by annealed approximation (Ch.2.2.3, Fig.5) and depend first of all on s and secondly on K . Dependency on N is searched, therefore not the absolute values of dmx or Lmx , but departures of these values are interesting. These departures are in the range of point 2, i.e. 'finite size effects'. However, absolute value for particular N also influences peaks separation (2.d). Degree of chaos c (1.b) also have asymptotic value for infinite N for particular case of network *type* and parameters s, K . In such a case maturation of chaos is mainly a domain of aspect 2 - disappearance of finite size effect. In its range exist qualitative aspects of shape and clarity of separation of both peaks from which should be taken more measurable phenomenon - appearance of zero frequency (blue bay) between peaks. Its existence does not depend on connection to environment (upper row in Fig.7).

Each of analysed relations seems to be dependent in a different way on the observed parameters in detail, but generally they give similar conclusions. Differences in these relations' behaviour suggest that they are at least three or four different mechanisms. Each of them seems to be near 'scale free' and therefore there is no critical points in them which means that for a particular threshold, an arbitrary value must be chosen depending on our intention and needs (when properties of small network can be neglected). The last criterion (i.e. appearance of zero frequency between peaks) seems to be the most 'correct' and useful. It shifts very slowly with the growth of statistics (event number). This shift needs more investigation. This criterion works correctly only for networks with feedbacks. For a network without feedbacks (which in described reality is a strange case) it can be used with approximation. This theme will be discussed in Ch.3.3.

3.2.3 Two causes of dispersion, reversed-annealed simulation

Separation level of the left and right peaks depends on the wideness of the right one but what are the sources of this wideness? Two of them can be expected:

1- Necessary effects of taken parameters m for L and N for d , when it is described by a binomial

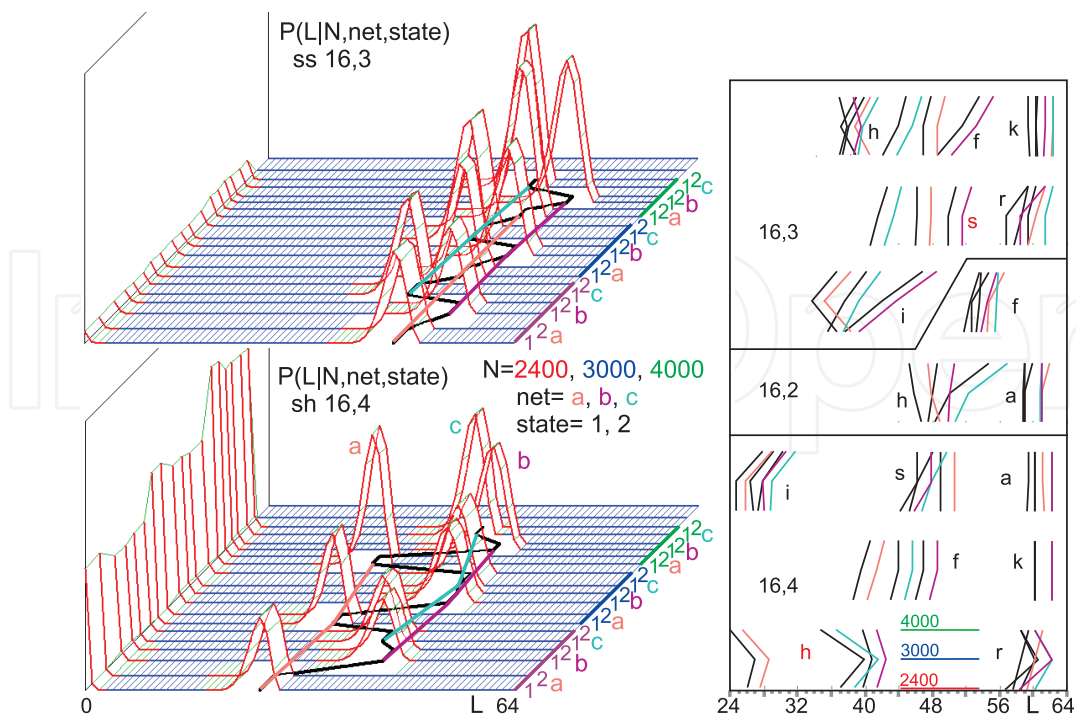

Fig. 8. Individual structure influence on the right peak width. Extreme examples of differences in 3 particular networks (a, b, c) on $N=2400, 3000, 4000$ measured two times, the second time after a random change of all node states, while keeping the structure stable. Value of shift is larger ($s=16$) than the width of peak which is exactly repeatable (two consecutive cases 1 and 2). The stable character of deviation for a particular network during its three steps of growth is visible, especially in the right diagram. Compare to er which doesn't grow. This diagram contains all the simulated cases depicted only as points of maximum (colour lines) and its standard deviation (black lines).

distribution if each node or output signal has equal probability to be damaged. Such a simple model works too well. For $L K = 2$ the comparison theoretical standard deviation to the experimental data are in the range of error (10%) but for $K = 3$ and $K = 4$ the obtained standard deviation is a little bit lower than theoretical which needs correction of assumption. It also approximately explains well the shapes for d and ak network, however, for $K < 4$ experimental standard deviations are greater than the theoretical ones; up to two times for $s, K=4,2$. This discrepancy has unknown source, it grows for more chaotic networks and reaches a 4 times higher value for $sh 4,2$. This study of dispersion sources is only a preliminary investigation.

2- Each particular network has its own particular individual structure which should cause a deviation from the average behaviour. Above I remark (Ch.3.2.1) that for $s=16$ where only 5 networks were used for the last $N=4000$, large fluctuations are observed. To confirm that the fluctuation source is the structure, and to get a scale of this phenomenon three networks were simulated for $N=2400, 3000$ and 4000 . For each N level two damage measurements were performed: one with node states as they were obtained during network growth and the second one with new random states of all nodes. Fig.8 shows two of the most extreme examples ($ss 16,3$ and $sh 16,4$) of the effects of this experiment in the form of full distributions. All results in the form of three points of the right peak's maximum, connected by line in the according colour accomplished by black line showing standard deviation are also shown.

As was expected, effects of changing node states and original states are identical. This method resembles the annealed model Derrida & Pomeau (1986); Kauffman (1993) but reversed: in the original annealed model, the states are kept and the structure is changed. This is the source of the algorithm name: 'reversed annealed'. Please note that for these simulations it is not necessary to use particular functions for nodes. Such functions are used (Gecow, 2009a) for certain structural tendencies simulation. As can be seen in Fig.8 in the right diagram, deviations are typically stable during the next levels N of network growth and the distances of peak maxims are larger than the standard deviation of peaks for one network. It is probably an effect of hubs and blind nodes as more chaotic networks (aa, ak, er) exhibit the effect in a much smaller way. For ss, si, sf and sh the wideness of total and individual peaks, and their absolute differences consecutively grow and are relatively and absolutely the biggest for sh , but it depend on K and s parameters.

3.3 Explanation of two peaks

Two separated peaks, one for real fade out and the second for pseudo fade out are an assumption of the simplified algorithm ('reversed annealed') used for simulation. Using this algorithm I investigated these two peaks and the appearance of the right one. Is it a tautology? No, however, in the area where the second peak emerges, this algorithm is not clear and may produce effects which are not exactly correct. Such effects have no clear interpretation. Thus, it is desirable to model this area in another way to understand why we should expect two peaks and why they are not present from the beginning. Percolation theory is a known theory which explain these two peaks. Another way for intuition for a different point of view and different aspects will be shown here.

3.3.1 Extremely simple lw network and cone of influence

A good place to begin is the extremely simple network depicted in Fig.9 upper row on the right. Imagine that there are 32 nodes in each level. Each node has two inputs and two outputs like aa network for $K = 2$. Nodes from one level are connected to higher level nodes in an extremely ordered way depicted in the figure. To eliminate boundaries on the left and right a cylinder is created. Network ends at the top in external outputs of network which send signals to the environment as a result of network function. I, however, will consider network outputs in a more complicated way. I name this network ' lw ' - ' l ' because it has clear levels and ' w ' because this letter is similar to the connection pattern.

The lw network does not contain feedbacks, it is probably the most ordered one in the sense of simplicity of connection pattern which requires an extremely small amount of information for its description. Only for a similarly simple network can one draw on paper a 'cone of influence' for a given node. The cone contains in its 'later' part, all nodes which can be damaged if the given one (in the vertex of cone) is damaged. Outputs are the base of the cone. Arrows depict the direction of signal flow which means that lw is a directed and functioning network like all the networks of our interest (RSN) Gecow (2010). In such a case, information in the form of signals flows up from the bottom (if cylinders stand up); this is functional order (or sequence) which defines terms 'early', 'later' and 'terminal' (closely near outputs, at the end of signal path). A similar phenomenon named 'supremacy' is investigated in Holyst et al. (2004) in a more theoretical way for directed scale-free network.

Levels can be numbered by number H (height) starting from an indicated node, however, nodes are similar and such a method is not stable. It can be substituted by a numbering which starts from the stable outputs therefore, such numbering is a depth D measure. The depth

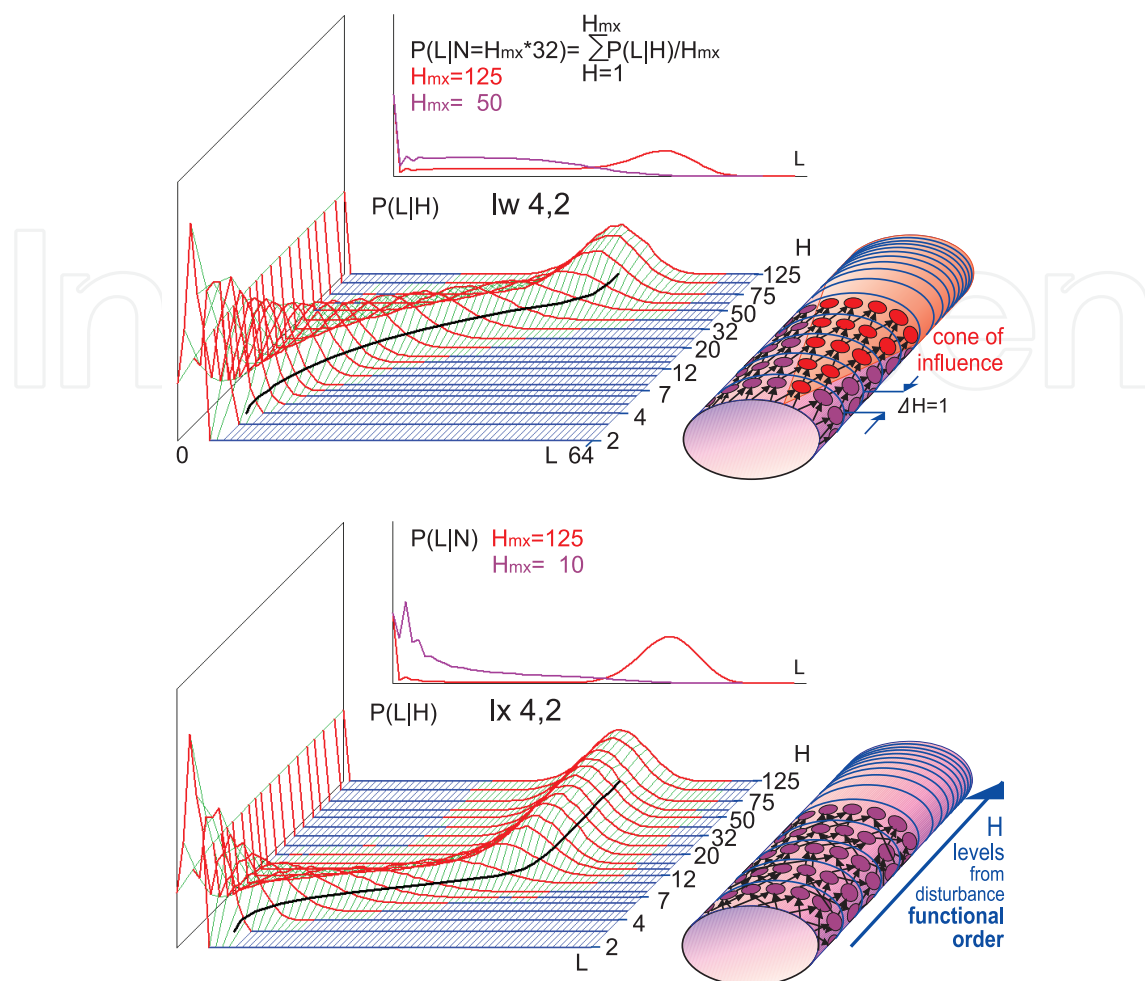

Fig. 9. Definitions of: *lw* and *lx* networks, cone of influence, functional order and levels. $P(L|H)$ - damage size distribution for consecutive levels H (if initiation was made in depth $D = H$), and $P(L|N)$ - damage size L distribution for networks which are Hmx high (all depth D are equally probable, $N = Hmx * 32$)

D is a useful structural substitution of the functional sequence. For a cone of influence it is the height of it, which indicates the number of outputs which can be reached by damage initialised in the vertex of the cone. Not all of the later nodes and network outputs will be damaged. The density of filling the cone by damage depends on the coefficient w of damage propagation described in Ch.2.2.1 and Ref. Gecow (2010). If $w > 1$ and damage does not fade out in the first few steps, then it also becomes a cone and is greater for greater cone height.

3.3.2 Damage on outputs and damage path through network without feedbacks, complexity

Next, the distribution of number L of damaged output signals in dependency on depth D will be examined. As an equivalent of using the depth D for the real network outputs, the sets of node outputs in consecutive higher levels (numbered by H) from initiation of damage can be watched. In Fig.9 this process is shown for $s = 4$. The levels are numbered with H but for comparison to the old known term, it can be calculated $N = H * 32$ which is the number of nodes in levels from initiation of damage. As in Fig.7 there are two peaks, zero in-between and the process of emergence of the right peak, however, it does not yet correspond with Fig.7.

To obtain the same meaning as in Fig.7 the height of the full network (which we can assume to be equal to Hmx) must be defined. Distributions from all equally probable levels (from the beginning to the shown one = Hmx) must also be summarized. The result is also shown in Fig.9, but only for two heights Hmx of network (for $Hmx, N = 10,320$ for lx or $50,1600$ for lw and $125,4000$ for both). Now we also find two peaks, but in-between there cannot be zero because middle levels exist and were summarized.

Let a part of 'order' from the description of structure be removed using random connection between neighbouring levels. Much more information for the description of such a particular network is necessary those it is more complex. I use the name ' lx ' for this network (Fig.9 lower row in the right). In the left it depicts the damage propagation for lx in consecutive distributions of damage size for growing distance from the initiation point as above for lw . For lx the right peak reaches its stable position much faster and the transitional stages contribute much less to the sum between peaks, which is visible in $P(L|N)$ (here N is used to distinguish $P(L|H)$ for particular level and summarized case for all levels from initiation point to Hmx). When s grows, e.g. two times; from 4 to 8, then the effect is similar to an increase of complexity. Much more is necessary to know in order to describe such a particular network with states, and the right peak reaches a stable position two times faster.

3.3.3 Damage path through network with feedbacks

It is now necessary to discuss the network case with feedbacks. This question crops up: how deep is a particular place of damage initiation in such a network? This question can be translated into a question about the length of path from initiation point to outputs, however, in opposite to networks lw and lx such paths typically are very different and the clear answer is not defined. They are different for two reasons. First, because clear levels used in lw and lx are a strong assumption which must not be taken even for network without feedbacks, e.g. for *an* network described in Ref. Gecow (2008). The second reason is because feedbacks make such a measure undefined.

Feedbacks are the loops in which signals and damage can loop many times even up to infinity therefore there is no longest path, but the shortest path, which is only defined, is not very adequate. This theme is discussed more widely in Ref. (Gecow, 2009b). In a typical randomly constructed network there are a lot of feedbacks, they are a cause of the equilibrium state of damage which should remain stable to infinity. If damage passes the first period when it is small and has real probability of fade out, then it reaches the feedbacks loops and its path through network will be infinite. It corresponds to an infinite depth of initiation, still, outputs may also be reached fast. Therefore in a network with feedbacks there are no middle paths and middle damage sizes placed between peaks. Then in this area zero frequency occurs. This zero means that the network is so large that feedbacks are reached quickly (after a short way, frequently) enough that middle ways cannot happen.

For a network without feedbacks there remains the criterion (of matured chaos) based on the stable position of the right peak and for practice some arbitrary percent of asymptotical level should be used. A large flat area between peaks of small value of probability in comparison to the right peak may be taken as a good approximation of zero occurrence.

4. Conclusion

In comparison to the main stream of investigation of transition to chaos which concerns the exact 'edge of chaos' ($K \leq 2, s = 2$) on the K axis, my approach expands s dimension (more equally probable signal variants) and moves attention into the area known as chaotic ($K \geq 2,$

$s \geq 2$ without the case $s, K = 2, 2$) and large networks. When network is small, it typically is not chaotic, then (matured) chaos emerges during its growth. Investigation of this emerging reaches much higher network sizes ($N = 4000$ even for $s, K = 4, 4$ and $16, 3$). In this area another transition to 'matured' chaos and its threshold is investigated, now on the N axis which is another, independent dimension of searched space.

The 'matured chaos' in context of network size N is an effect of the disappearance of finite size effect during network growth. Important part of causes the effect is constant special node - connection to environment. Three or four independent mechanisms can be seen. Each of them seems to be near 'scale free' and therefore there are no critical points in them which means that for particular threshold an arbitrary value must be chosen depending on our needs. Appearance of zero frequency between peaks in damage size distribution seems to be the most 'correct' and useful criterion of matured chaos.

Living systems are shifted following Ref. Gecow (2010) to 'matured chaos' onto the opposite shore of Kauffman's liquid region near the 'edge of chaos'. Evolution of living systems needing small changes is placed in the left peak of damage size distribution which was underestimated up till now. An other-than-zero limitation of order degree r (fraction of damage initiation which do not convert into large avalanche and create the left peak) found in the described experiment takes up the importance of this place.

5. References

- R. Albert, A.-L. Barabási, 2002. Statistical mechanics of complex networks. *Rev. Mod. Phys.*, 74,1, 47–97
- R. Albert, H.G. Othmer, 2003. The topology of the regulatory interactions predicts the expression pattern of the segment polarity genes in *Drosophila melanogaster*. *J. Theor. Biol.* 223. 1–18
- M. Aldana, 2003. Dynamics of Boolean Networks with Scale Free Topology. *Physica D* 185, 45–66
- M. Aldana, S. Coppersmith, L. P. Kadanoff, 2003. Boolean Dynamics with Random Couplings. in *Perspectives and Problems in Nonlinear Science, Applied Mathematical Sciences Series*, ed. E. Kaplan, J. E. Marsden, K. R. Sreenivasan (Springer-Verleg, Berlin).
- W. R. Ashby, 1960. *Design for a Brain* 2nd edn. (Wiley, New York)
- P. Bak, 1996. *How Nature Works: The Science of Self-Organized Criticality*, New York: Copernicus.
- F. J. Ballesteros, B. Luque, 2005. Phase transitions in random networks: Simple analytic determination of critical points. *Phys. Rev. E* 71, 031104
- W. Banzhaf, 2003. On the Dynamics of an Artificial Regulatory Network. In *Advances in Artificial Life, 7th European Conference, ECAL'03, LNAI Springer*, 2801, 217–227
- A.-L. Barabási, R. Albert, H. Jeong, 1999. Mean-field theory for scale-free random networks. *Physica A* 272, 173–187
- A.-L. Barabási, E. Bonabeau, 2003. Scale-Free Networks. *Scientific American* 50–59
- P. Crucitti, V. Latora, M. Marchiori, A. Rapisarda, 2004. Error and attacktolerance of complex networks *Physica A* 340 388–394
- B. Derrida, Y. Pomeau, 1986. Random Networks of Automata: A Simple Annealed Approximation. *Europhys. Lett.*, 1(2), 45–49
- B. Derrida, G. Weisbuch, 1986. Evolution of Overlaps Between Configurations in Random Boolean Networks. *Journal De Physique* 47, 1297– 1303.
- P. Erdős and A. Rényi, 1960. Random graphs. Publication of the Mathematical Institute of the Hungarian Academy of Science, 5, 17–61

- J. D. Farmer, S. Kauffman, N. H. Packard, 1986. Autocatalytic Replication of Polymers. *Physica D* 22(1-3), 50–67.
- S. Fortunato, 2005. Damage spreading and opinion dynamics on scale-free networks. *Physica A* 348, 683–690
- P. Fronczak, A. Fronczak, J.A. Holyst, 2008. Kauffman Boolean model in undirected scale-free networks. *Phys. Rev. E* 77, 036119
- L.K. Gallos, P. Argyrakis, A. Bunde, R. Cohen, S. Havlin, 2004. Tolerance of scale-free networks: from friendly to intentional attack strategies. *Physica A* 344, 504 - 509
- A. Gecow, 1975. A cybernetic model of improving and its application to the evolution and ontogenesis description. In: *Fifth International Congress of Biomathematics Paris*
- A. Gecow, A. Hoffman, 1983. Self-improvement in a complex cybernetic system and its implication for biology. *Acta Biotheoretica* 32, 61–71
- A. Gecow, M. Nowostawski, M. Purvis, 2005. Structural tendencies in complex systems development and their implication for software systems. *J.UCS*, 11,2 327–356
- A. Gecow, 2005a. From a “Fossil” Problem of Recapitulation Existence to Computer Simulation and Answer. *Neural Network World. Acad. Sci. Czech Rep.*3/2005, 189–201
- A. Gecow, 2008. Structural Tendencies - effects of adaptive evolution of complex (chaotic) systems. *Int.J Mod.Phys.C*, 19, 4, 647–664.
- A. Gecow, 2009. Emergence of Chaos and Complexity During System Growth. In *From System Complexity to Emergent Properties*. M.A. Aziz-Alaoui & Cyrille Bertelle (eds), Springer, Understanding Complex Systems Series, 115–154
- A. Gecow, 2009a. Emergence of Growth and Structural Tendencies During Adaptive Evolution of System. In as above, 211–241
- A. Gecow, 2009b. The conditions of structural tendencies. In *Modelling and Analysis of Complex Interacting Systems*. M.A. Aziz-Alaoui & Cyrille Bertelle (eds), DCDIS-B, 551–572
- A. Gecow, 2010. More Than Two Equally Probable Variants of Signal in Kauffman Networks as an Important Overlooked Case, Negative Feedbacks Allow Life in the Chaos. arXiv:1003.1988v1
- A. Gecow, 2010a. Complexity Threshold for Functioning Directed Networks in Damage Size Distribution. arXiv:1004.3795v1
- C. Gershenson, 2004. Updating Schemes in Random Boolean Networks: Do They Really Matter? arXiv:nlin/0402006v3
- A. Grabowski, R.A. Kosiński, 2004. Epidemic spreading in a hierarchical social network. *Phys.Rev.E*, 70, 031908
- A. Grabowski, R.A. Kosiński, 2006. Ising-based model of opinion formation in a complex network of interpersonal interactions. *Physica A*, 361, 651-664
- S. E.Harris, B.K. Sawhill, A. Wuensche, S.A. Kauffman, 2002. A model of transcriptional regulatory networks based on biases in the observed regulation rules. *Complexity* 7, 23
- G. Ito, 2008. A Dynamical Boolean Network. arXiv:0804.1179v3
- J. H. Holland, 1998. *Emergence: from chaos to order*. Oxford University Press
- J.A. Holyst, A.Fronczak, and P.Fronczak, 2004. Supremacy distribution in evolving networks. *Phys. Rev. E* 70, 046119
- T. R. Hughes et al., 2000. Functional discovery via a compendium of expression profiles. *Cell* textbf102, 109–126.

- K. Iguchi, S.-i. Kinoshita, H. Yamada, 2007. Boolean dynamics of Kauffman models with a scale-free network. *J. Theor. Biol.* 247, 138–151
- N. Jan, L. de Arcangelis, 1994. Computational Aspects of Damage Spreading. In: *Annual Reviews of Computational Physics I*, ed by D. Stauffer (World Scientific, Singapore) 1–16
- S.A. Kauffman, 1969. Metabolic stability and epigenesis in randomly constructed genetic nets. *J. Theor. Biol.* 22, 437–467
- S.A. Kauffman, 1971. Gene regulation networks: a theory for their global structure and behaviour. *Current topics in dev. biol.* 6, 145.
- S.A. Kauffman, 1993. *The Origins of Order: Self-Organization and Selection in Evolution* (Oxford University Press New York)
- S.A. Kauffman, C. Peterson, B. Samuelsson, C. Troein, 2004. Genetic networks with canalizing Boolean rules are always stable. *PNAS* 101,49, 17102–17107
- J. F. Knabe, C. L. Nehaniv, M. J. Schilstra, T. Quick, 2006. Evolving Biological Clocks using Genetic Regulatory Networks. In *Proceedings of the Artificial Life X Conference (Alife 10)*, 15–21, MIT Press
- B. Korzeniewski, 2001. Cybernetic formulation of the definition of life. *J.Theor.Biol.* 209, 275
- B. Korzeniewski, 2005. Confrontation of the cybernetic definition of living individual with the real world. *Acta Biotheoretica* 53, 1–28
- B. Luque, R.V. Solé, 1997. Phase transitions in random networks: Simple analytic determination of critical points. *Phys. Rev. E* 55(1), 257–260
- B. Luque, F.J. Ballesteros, 2004. Random walk networks. *Physica A* 342 207–213
- P. Rämö, J. Kesseli, O. Yli-Harja, 2006. Perturbation avalanches and criticality in gene regulatory networks. *J. Theor. Biol.* 242 164–170
- H. Schuster, 1984. *Deterministic Chaos: An Introduction*. Physik-Verlag
- R. Serra, M. Villani, A. Semeria, 2004. Genetic network models and statistical properties of gene expression data in knock-out experiments. *J. Theor. Biol.* 227, 149–157
- R. Serra, M. Villani, L. Agostini, 2004a. On the dynamics of random Boolean networks with scale-free outgoing connections. *Physica A* 339 665 – 673
- R. Serra, M. Villani, A. Graudenzi, S. A. Kauffman, 2007. Why a simple model of genetic regulatory networks describes the distribution of avalanches in gene expression data. *J. Theor. Biol.* 246 449–460
- R. Serra, M. Villani, A. Barbieri, S. A. Kauffman, A. Colacci, 2010. On the dynamics of random Boolean networks subject to noise: attractors, ergodic sets and cell types. *J. Theor. Biol.* 265, 185–193
- I. Shmulevich, E.R. Dougherty, W. Zhang, 2002. From Boolean to Probabilistic Boolean Networks as Models of Genetic Regulatory Networks. *Proc. IEEE*, 90(11), 1778–1792
- I. Shmulevich, S. A. Kauffman, M. Aldana, 2005. Eukaryotic cells are dynamically ordered or critical but not chaotic. *PNAS* 102 (38), 13439–13444
- R.V. Sole, B. Luque, S. Kauffman, 2000. Phase transitions in random networks with multiple states. Technical Report 00-02-011, Santa Fe Institute
- A.O. Sousa, 2005. Consensus formation on a triad scale-free network. *Physica A* 348 701–710
- A. Wagner, 2001. Estimating coarse gene network structure from large-scale gene perturbation data. Santa Fe Institute Working Paper, 01-09-051.

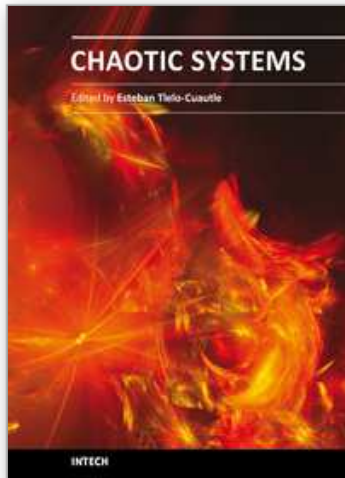

Chaotic Systems

Edited by Prof. Esteban Tlelo-Cuautle

ISBN 978-953-307-564-8

Hard cover, 310 pages

Publisher InTech

Published online 14, February, 2011

Published in print edition February, 2011

This book presents a collection of major developments in chaos systems covering aspects on chaotic behavioral modeling and simulation, control and synchronization of chaos systems, and applications like secure communications. It is a good source to acquire recent knowledge and ideas for future research on chaos systems and to develop experiments applied to real life problems. That way, this book is very interesting for students, academia and industry since the collected chapters provide a rich cocktail while balancing theory and applications.

How to reference

In order to correctly reference this scholarly work, feel free to copy and paste the following:

Andrzej Gecow (2011). Emergence of Matured Chaos During Network Growth, Place for Adaptive Evolution and More of Equally Probable Signal Variants as an Alternative to Bias p, Chaotic Systems, Prof. Esteban Tlelo-Cuautle (Ed.), ISBN: 978-953-307-564-8, InTech, Available from:

<http://www.intechopen.com/books/chaotic-systems/emergence-of-matured-chaos-during-network-growth-place-for-adaptive-evolution-and-more-of-equally-pr>

INTECH

open science | open minds

InTech Europe

University Campus STeP Ri
Slavka Krautzeka 83/A
51000 Rijeka, Croatia
Phone: +385 (51) 770 447
Fax: +385 (51) 686 166
www.intechopen.com

InTech China

Unit 405, Office Block, Hotel Equatorial Shanghai
No.65, Yan An Road (West), Shanghai, 200040, China
中国上海市延安西路65号上海国际贵都大饭店办公楼405单元
Phone: +86-21-62489820
Fax: +86-21-62489821

© 2011 The Author(s). Licensee IntechOpen. This chapter is distributed under the terms of the [Creative Commons Attribution-NonCommercial-ShareAlike-3.0 License](#), which permits use, distribution and reproduction for non-commercial purposes, provided the original is properly cited and derivative works building on this content are distributed under the same license.

IntechOpen

IntechOpen