

# We are IntechOpen, the world's leading publisher of Open Access books Built by scientists, for scientists

4,800

Open access books available

122,000

International authors and editors

135M

Downloads

Our authors are among the

154

Countries delivered to

TOP 1%

most cited scientists

12.2%

Contributors from top 500 universities



WEB OF SCIENCE™

Selection of our books indexed in the Book Citation Index  
in Web of Science™ Core Collection (BKCI)

Interested in publishing with us?  
Contact [book.department@intechopen.com](mailto:book.department@intechopen.com)

Numbers displayed above are based on latest data collected.  
For more information visit [www.intechopen.com](http://www.intechopen.com)



# New Trends in Efficiency Optimization of Induction Motor Drives

Branko Blanusa

*University of Banja Luka, Faculty of Electrical Engineering  
Bosnia and Herzegovina*

## 1. Introduction

Scientific considerations presented in this paper are related to the methods for power loss minimization in induction motor drives.

The induction motor is without doubt the most used electrical motor and a great energy consumer. Three-phase induction motors consume 60% of industrial electricity and it takes considerable efforts to improve their efficiency (Vukosavic, 1998). The vast majority of induction motor drives are used for heating, ventilation and air conditioning (HVAC). These applications require only low dynamic performance and in most cases only voltage source inverter is inserted between grid and induction motor as cheapest solution. The classical way to control these drives is constant V/f ratio and simple methods for efficiency optimization can be applied (Abrahamsen et al., 1998). From the other side there are many applications where, like electrical vehicles, electric energy has to be consumed in the best possible way and use of induction motors in such application requires an energy optimized control strategy (Chis et al., 1997).

The evolution of the power digital microcontrollers and development of power electronics enables applying not only methods for induction motor drives (IMD) control, like vector control or direct torque control, but also development of different functions which make drives more robust and more efficient. One of the more interesting algorithm which can be applied in a drive controller is algorithm for efficiency optimization.

In a conventional setting, the field excitation is kept constant at rated value throughout its entire load range. If machine is under-loaded, this would result in over-excitation and unnecessary copper losses. Thus in cases where a motor drive has to operate in wider load range, the minimization of losses has great significance. It is known that efficiency improvement of IMD can be implemented via motor flux level and this method has been proven to be particularly effective at light loads and in a steady state of drive. Also flux reduction at light loads gives less acoustic noise derived from both converter and machine. From the other side low flux makes motor more sensitive to load disturbances and degrades dynamic performances (Stergaki & Stavrakakis, 2008).

The published methods mainly solve the problem of efficiency improvement for constant output power. Results of applied algorithms highly depends from the size of drive (fig. 1) (Abrahamsen et al., 1998) and operating conditions, especially load torque and speed (Figs. 2 and 3). Efficiency of IM changes from 75% for low power 0,75kW machine to more than 95% for 100kW machine. Also efficiency of drive converter is typically 95% and more.

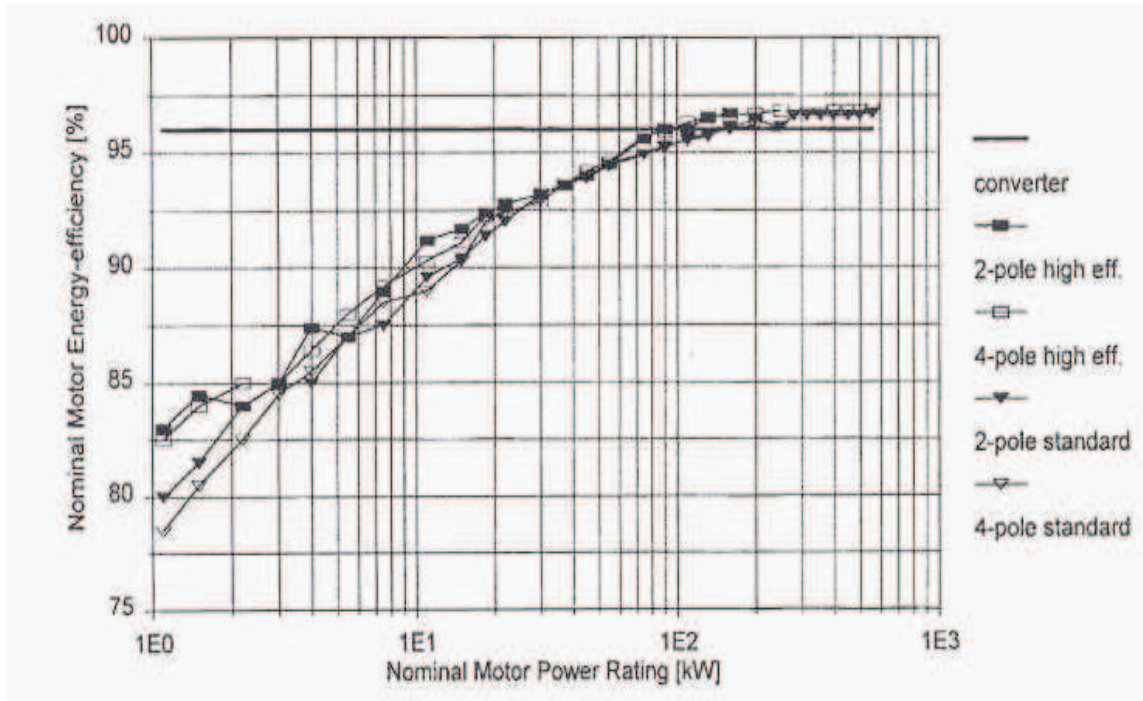

Fig. 1. Rated motor efficiencies for ABB motors (catalog data) and typical converter efficiency.

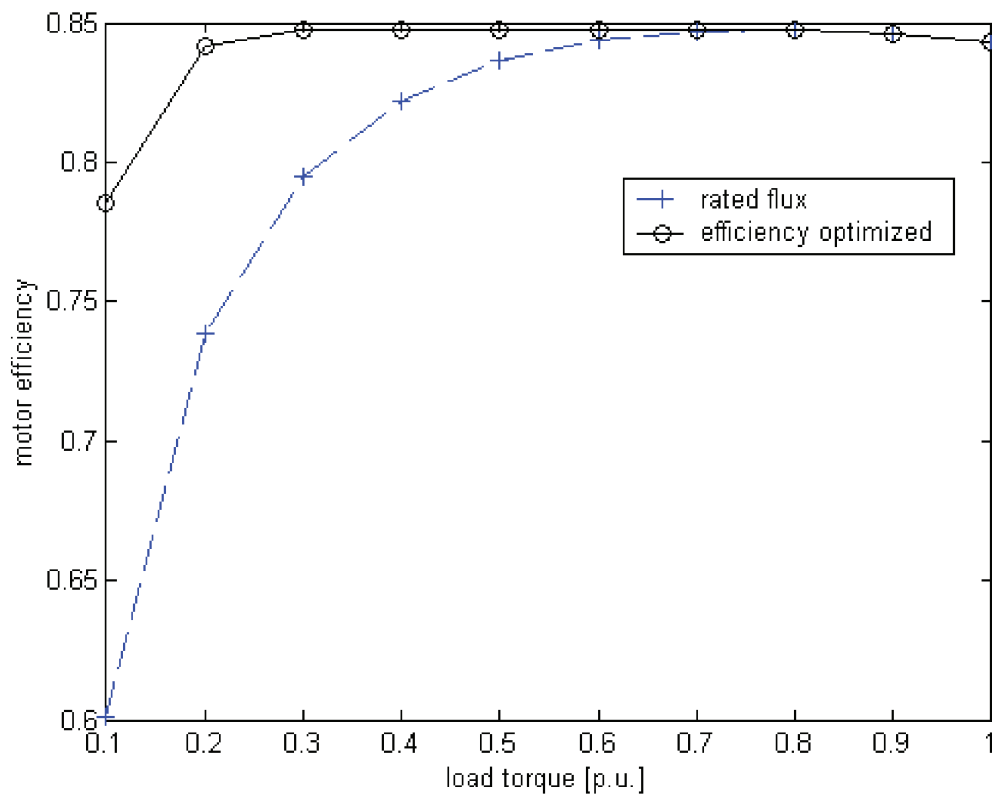

Fig. 2. Measured standard motor efficiencies with both rated flux and efficiency optimized control at rated mechanical speed (2.2 kW rated power).

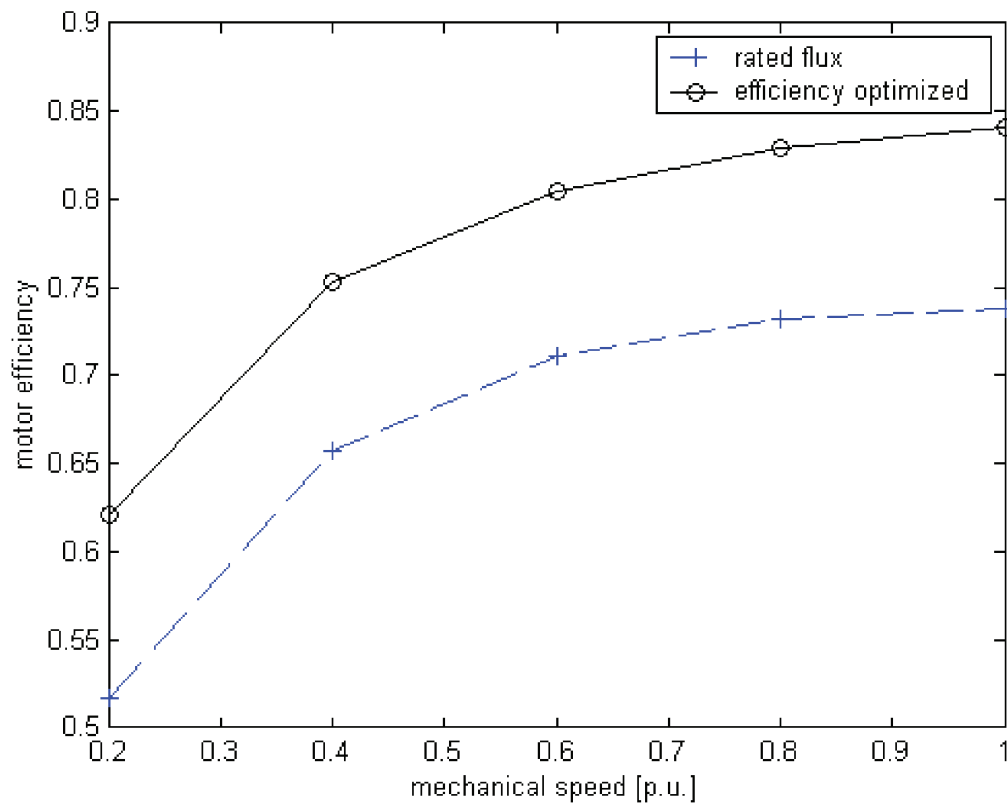

Fig. 3. Measured standard motor efficiencies with both rated flux and efficiency optimized control at light load (20% of rated load).

That's obvious, converter losses is not necessary to consider in efficiency optimal control for small drives. Best results in efficiency optimization can be achieved for a light loads and steady state of drive.

Functional approximation of the power losses in the induction motor drive is given in second section.

Basic concepts strategies for efficiency optimization of induction motor drive what includes its characteristics, advantages and drawbacks are described in third section.

Implementation of modern technique for efficiency optimization of IMD based on fuzzy logic, artificial neural networks and torque reserve control are presented in fourth section.

Efficiency optimized control for closed-cycle operation of high performance IMD is presented in fifth section. The mathematical concept for computing optimal control, based on the dynamic programming approach, is described.

At the end, conclusion summarises the results achieved, implementation possibilities and directions of further research in this field.

## 2. Functional approximation of the power losses in the induction motor drive

The process of energy conversion within motor drive converter and motor leads to the power losses in the motor windings and magnetic circuit as well as conduction and commutation losses in the inverter.

The overall power losses ( $P_{tot}$ ) in electrical drive consists of converter losses ( $P_{inv}$ ) and motor losses ( $P_{mot}$ ), while motor power losses can be divided in copper ( $P_{Cu}$ ) and iron losses ( $P_{Fe}$ ) (Uddin & Nam, 2008):

$$\begin{aligned} P_{tot} &= P_{mot} + P_{inv} \\ P_{mot} &= P_{Cu} + P_{Fe} \end{aligned} \quad (1)$$

Converter losses: Main constituents of converter losses are the rectifier, DC link and inverter conductive and inverter commutation losses. Rectifier and DC link inverter losses are proportional to output power, so the overall flux-dependent losses are inverter losses. These are usually given by:

$$P_{inv} = R_{inv} \cdot i_s^2 = R_{inv} \cdot (i_d^2 + i_q^2), \quad (2)$$

where  $i_d, i_q$  are components of the stator current  $i_s$  in  $d,q$  rotational system and  $R_{inv}$  is inverter loss coefficient.

Motor losses: These losses consist of hysteresis and eddy current losses in the magnetic circuit (core losses), losses in the stator and rotor conductors (copper losses) and stray losses. At nominal operating point, the core losses are typically 2-3 times smaller than the copper losses, but they represent main loss component of a highly loaded induction motor drives (Vukosavic & Levi, 2003). The main core losses can be modeled by (Blanusa, et al., 2006):

$$P_{Fe} = c_h \Psi_m^2 \omega_e + c_e \Psi_m^2 \omega_e^2, \quad (3)$$

where  $\Psi_m$  is magnetizing flux,  $\omega_e$  supply frequency,  $c_h$  is hysteresis and  $c_e$  eddy current core loss coefficient.

Copper losses are due to flow of the electric current through the stator and rotor windings and these are given by:

$$p_{Cu} = R_s i_s^2 + R_r i_q^2, \quad (4)$$

The stray flux losses depend on the form of stator and rotor slots and are frequency and load dependent. The total secondary losses (stray flux, skin effect and shaft stray losses) usually don't exceed 5% of the overall losses. Considering also, that the stray losses are of importance at high load and overload conditions, while the efficiency optimizer is effective at light load, the stray losses are not considered as a separate loss component in the loss function. Formal omission of the stray loss representation in the loss function have no impact on the accuracy algorithm for on-line optimization (Vukosavic & Levi, 2003).

Based on previous consideration, total flux dependent power losses in the drive are given by the following equation:

$$P_{tot} = (R_{inv} + R_s) i_d^2 + (R_{inv} + R_s + R_r) i_q^2 + c_e \omega_e^2 \Psi_m^2 + c_h \omega_e \Psi_m^2. \quad (5)$$

Efficiency algorithm works so that flux in the machine is less or equal to its nominal value:

$$\Psi_D \leq \Psi_{Dn}, \quad (6)$$

where  $\Psi_{Dn}$  is nominal value of rotor flux. So linear expression for rotor flux can be accepted:

$$\frac{d\Psi_D}{dt} = \frac{R_r}{L_r} L_m i_d - \frac{R_r}{L_r} \Psi_D, \quad (7)$$

where  $\Psi_D = L_m i_d$  in a steady state.

Expression for output power can be given as:

$$P_{out} = d \omega_r \Psi_D i_q \quad (8)$$

where  $d$  is positive constant,  $\omega_r$  angular speed,  $\Psi_D$  rotor flux and  $i_q$  active component of the stator current. Based on previous consideration, assumption that position of the rotor flux is correctly calculated, q component of rotor flux is equal 0 ( $\Psi_Q = 0$ ) and relation  $P_{in} = P_{tot} + P_{out}$ , output power can be given by the following equation:

$$P_{in} = a i_d^2 + b i_q^2 + c_1 \omega_e^2 \Psi_D^2 + c_2 \omega_e \Psi_D^2 + d \omega_r \Psi_D i_q \quad (9)$$

where  $a = R_s + R_{inv}$ ,  $b = R_s + R_{inv} + R_r$ ,  $c_1 = c_e$  and  $c_2 = c_h$ .

Input power should be measured and exact  $P_{out}$  is needed in order to acquire correct power loss and avoid coupling between load pulsation and the efficiency optimizer.

Total power losses can be calculated as difference between input and output drive power:

$$P_{tot} = P_{in} - P_{out} \quad (10)$$

where

$$P_{in} = V_{dc} \cdot I_{dc} \quad (11)$$

is input drive power and

$$P_{out} = \omega_r T_{em} \quad (12)$$

is output drive power.

Variables  $V_{dc}$  and  $I_{dc}$  are voltage and current in DC link. Electromagnetic torque  $T_{em}$  is known variable in a drive and speed  $\omega_r$  is measured or estimated. So, we can calculate power losses without knowledge of motor parameters and power loss calculation is independent of the motor parameter changes in the working area.

### 3. Strategies for efficiency optimization of IMD

Numerous scientific papers on the problem of loss reduction in *IMD* have been published in the last 20 years. Although good results have been achieved, there is still no generally accepted method for loss minimization. According to the literature, there are three strategies for dealing with the problem of efficiency optimization of the induction motor drive (Abrahamsen, et al., 1996):

1. Simple State Control (SSC) ,
2. Loss Model Control (LMC) and
3. Search Control (SC)

#### 3.1 Simple state control

The first strategy is based on the control of one of the variables in the drive (Abrahamsen, et al., 1996), (Benbouzid & Nait Said, 1998) (fig.4). This variable must be measured or estimated and its value is used in the feedback control of the drive, with the aim of running

the motor by predefined reference value. Slip frequency or power factor displacement are the most often used variables in this control strategy. Which one to choose depends on which measurement signals is available (Abrahamsen, et al., 1996). This strategy is simple, but gives good results only for a narrow set of operation conditions. Also, it is sensitive to parameter changes in the drive due to temperature changes and magnetic circuit saturation.

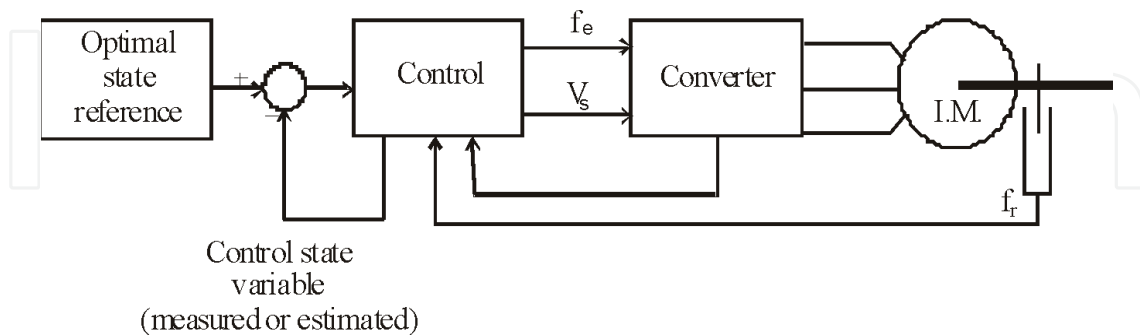

Fig. 4. Control diagram for the simple state efficiency optimization strategy.

### 3.2 Loss model control

In the second strategy, a drive loss model is used for optimal drive control (Fernandez-Barnal, et al., 2000), (Vukosavic & Levi, 2003) (fig. 5). These algorithms are fast because the optimal control is calculated directly from the loss model.

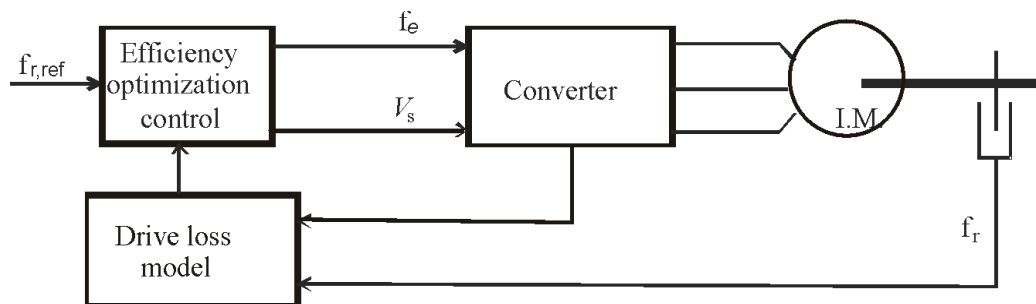

Fig. 5. Block diagram for the model based control strategy.

But, power loss modeling and calculation of the optimal operating conditions can be very complex. This strategy is also sensitive to parameter variations in the drive.

### 3.3 Search control

In the search strategy, the on-line procedure for efficiency optimization is carried out (Sousa at al., 1997), (Sousa at al., 2007), (Ghozzy et al., 2004) (fig. 6). The on-line efficiency optimization control on the basis of search, where the stator or rotor flux is decremented in steps until the measured input power settles down to the lowest value is very attractive.

Search strategy methods have an important advantage compared to other strategies. It is completely insensitive to parameter changes while effects of the parameter variations caused by temperature and saturation are very expressed in two other strategy.

Besides all good characteristics of search strategy methods, there is an outstanding problem in its use. When the load is low and optimal operating point is found, flux is so low that the motor is very sensitive to load perturbations. Also, flux convergence to its optimal value sometimes can be too slow, and flux never reaches the value of minimal losses then in small steps oscillates around it.

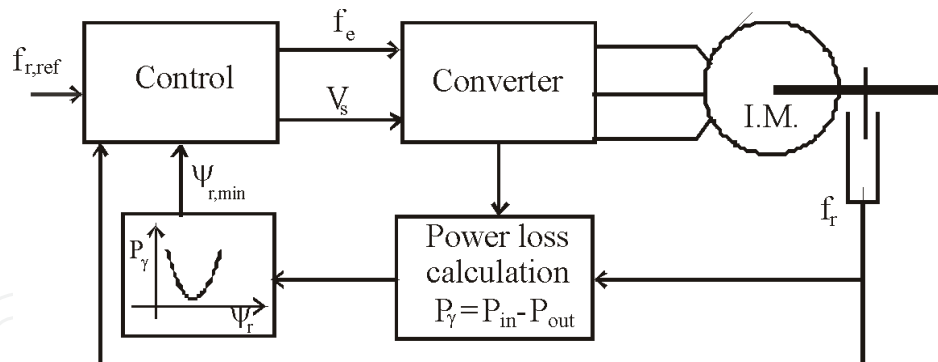

Fig. 6. Block diagram of search control strategy.

There are hybrid methods (Stergaki & Stavrakakis, 2008), (Chakaborty & Hori, 2003) which combine good characteristics of two optimization strategies SC and LMC and it was enhanced attention as interesting solution for efficiency optimization of controlled electrical drives .

#### 4. Modern technique for efficiency optimization of IMD

Power loss model is very attractive, because it is fast and magnetizing flux which gives minimum power losses can be calculated directly from loss model. Based on expression (8), (9) and (10) power losses can be expressed in terms related to  $i_d$ ,  $T_{em}$  and  $\omega_e$  as follows

$$P_{tot}(i_d, T_{em}, \omega_e) = (a + c_1 L_m^2 \omega_e^2 + c_2 L_m^2 \omega_e) i_d^2 + \frac{b T_{em}^2}{(d L_m i_d)^2} \tag{13}$$

Assuming absence of saturation and specifying slip frequency:

$$\omega_s = \omega_e - \omega_r = \frac{i_q}{T_r i_d} \tag{14}$$

power loss function can be expressed as function of current  $i_d$  and operational conditions ( $\omega_r$ ,  $T_{em}$ ):

$$P_{tot}(i_d, T_{em}, \omega_r) = (a + c_1 L_m^2 \omega_r^2 + c_2 L_m^2 \omega_r) i_d^2 + \frac{(2c_1 \omega_r + c_2) L_m T_{em}}{dT_r} + \left( c_1 \frac{T_{em}^2}{(dT_r)^2} + \frac{b T_{em}^2}{(dL_m)^2} \right) \frac{1}{i_d^2} \tag{15}$$

where  $T_r = L_r / R_r$ .

Based on equation (14), it is obvious, the steady-state optimum is readily found based upon the loss function parameters and operating conditions. Substituting  $\alpha = (a + c_1 L_m^2 \omega_r^2 + c_2 L_m^2 \omega_r)$

and  $\gamma = c_1 \frac{T_{em}^2}{d^2 T_r^2} + \frac{b T_{em}^2}{d^2 L_m^2}$  value of current  $i_d$  which gives minimal losses is:

$$i_{dLMC}^* = \left( \frac{\gamma}{\alpha} \right)^{0.25} \tag{16}$$

If the losses in the drive were known exactly, it would be possible to calculate the optimal operating point and control of drive in accordance to that. For the following reasons it is not possible in practice (Sousa et al., 1997).



1. Even though efficiency optimization could be calculated exactly, it is probably that limitation in computation power in industrial drives would make this impossible.
2. A number of fundamental losses are difficult to predict: stray load, iron losses in case of saturation changes, copper losses because of temperature rise etc.
3. Due to limitation in costs all the measurable signals can not be acquired. It means that certain quantities must be estimated which naturally leads to an error.
4. Parameters in the loss model are very sensitive to temperature rise, magnetic circuit saturation, skin effect and so on.

For above mentioned reasons it is impractically to calculate power losses on the basis of loss model.

Search algorithms do not require the knowledge of motor parameters and these are applicable universally to any motor. So there are very intensive research of these methods, especially on academic level. Search algorithms are usually based on the following methods (Moreno-Eguilaz, et al., 1997)

#### 4.1 Rosenbrock method

The flux is changed gradually in one direction if ( $\Delta P_{tot} < 0$ ). When algorithm detects change of power losses ( $\Delta P_{tot} > 0$ ), flux is changed in other direction, until the required accuracy is achieved:

$$\psi(n+1) = \psi(n) + k\Delta\psi(n); \quad k = \begin{cases} k = 1; \Delta P_{\gamma}(n) < 0 \\ k = -1; \Delta P_{\gamma}(n) > 0 \end{cases}$$

where  $\Delta P_{tot}(n) = P_{tot}(n+1) - P_{tot}(n)$  and  $\Delta\psi(n) = \psi(n+1) - \psi(n)$ . This method is simple, but flux convergence can be to slow.

#### 4.2 Proportional method

To accelerate flux convergence to its optimal value is possible to use not only the sign of the consumed power, but also the module of the input power. This can be expressed by:

$$\psi(n+1) = \psi(n) - k \operatorname{sgn}(\Delta\psi(n)),$$

where  $k$  is positive number. This algorithm presents convergence problems and oscillations if  $k$  is constant value. Better results are obtained if  $k$  is a nonlinear functions varying with system conditions.

#### 4.3 Gradient method

This algorithm is based on the gradient directions search methods, using the gradient of the input power. The gradient is computed using a 1<sup>st</sup> order liner approximation.

$$\psi(n+1) = \psi(n) - k\nabla P_{\gamma}(n).$$

This problem has problems around the optimum flux due to difficulty to obtain a good numerical approximation of the gradient.

#### 4.4 Fibonacci method

This method consists of sampling the input power of the motor working at different fluxes are function Fibonacci's series.

#### 4.5 Search methods based on Fuzzy Logic

Search controller is used during the steady states of drive. Based on expression (13) it can be concluded that function of power loss is nonlinear. Also controller of efficiency improvement should follow known rules. These are reasons why fuzzy logic is often used in realization of efficiency optimization controller. These obtains faster and smoothly convergence of flux to the value which gives minimal power losses for a given operating conditions. Typical SC optimization block is shown in fig. 7 (Liwei et al., 2006). Input variable in optimization controller is drive input power ( $P_{in}$ ), while output variable is new value of magnetization current ( $i_{dLMC}^*$ ). Fuzzy controller is very simple and it contains only one input and one output variable.

Scaling factors, input gain  $P_g$  and output gain  $I_g$  are calculated following the next expression (Liwei et al., 2006):

$$\begin{aligned} P_g &= P_{tot\_nom} - P_{totLMC} \\ I_g &= I_{dn} - i_{dLMC}^* \end{aligned} \quad (17)$$

where  $P_{tot\_nom}$  is power loss for nominal flux, and  $P_{tot\_opt}$  is power loss for optimal flux value calculated from loss model,  $I_{dn}$  is nominal and  $i_{dLMC}^*$  is optimal magnetizing current defined by (16).

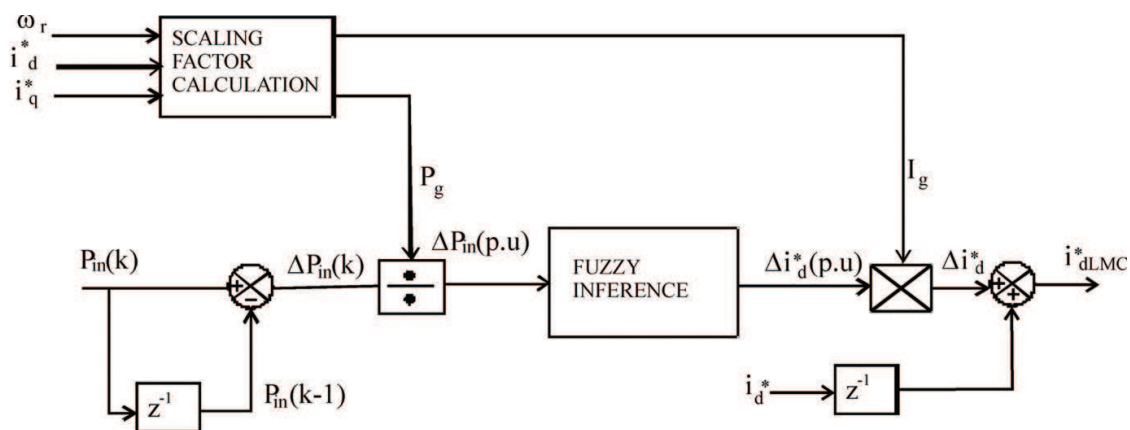

Fig. 7. SC efficiency optimization controller

#### 4.6 Torque reserve control in search methods for efficiency optimization

One of the greatest problem of *LMC* methods is its sensitivity on load perturbation, especially for light loads when the flux level is low. This is expressed for a step increase of load torque and then two significant problems are appeared:

- Flux is far from the value which gives minimal losses during transient process, so transient losses are expressed.
- Insufficiency in the electromagnetic torque leads output speed to converge slow to its reference value with significant speed drops. Also, oscillations in the speed response are appeared.

These are common problem of methods for efficiency optimization based on flux adjusting to load torque. Speed response on the step change of load torque (from 0.5 p.u. to 1.1 p.u.), for nominal flux and when *LMC* method is applied, is presented in the fig. 8. Speed drops and slow speed convergence to its reference value are more exposed for *LMC* method.

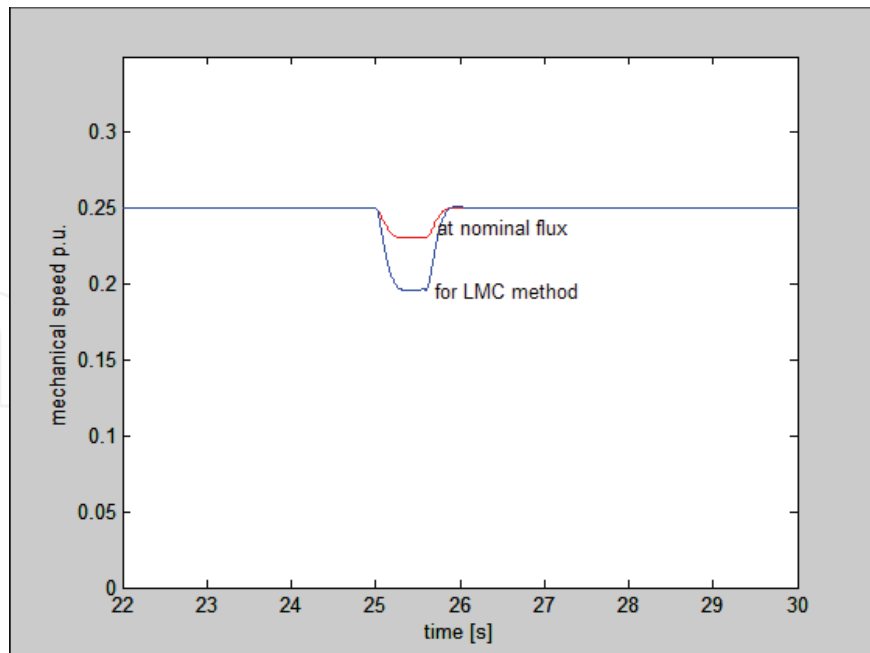

Fig. 8. Speed response on the step load increase for nominal flux and when LMC is applied.

These are reasons why torque reserve control in *LMC* method for efficiency optimization is necessary. Model of efficiency optimization controller with torque reserve control is presented in fig. 9 (Blanusa et al., 2006). Optimal value of magnetization current is calculated from the loss model and for given operational conditions (16). Fuzzy logic controller is used in determination of  $\Delta i_d$ , on the basis of the previously determined torque reserve ( $\Delta T_{em}$ ). Controller is very simple, and there is one input, one output and 3 rules. Only 3 membership functions are enough to describe influence of torque reserve in the generation of  $i_{dopt}^*$ .

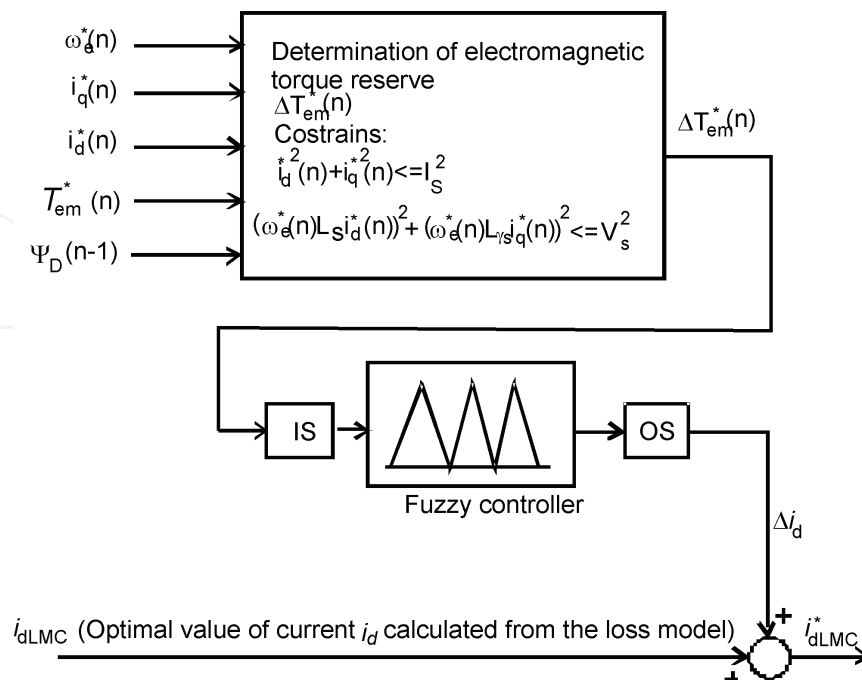

Fig. 9. Block for efficiency optimization with torque reserve control.

If torque reserve is sufficient then  $\Delta i_d \approx 0$  and this block has no effect in a determination of  $i_{dLMC}^*$ . Oppositely, current  $i_d$  (magnetization flux) increases to obtain sufficient reserve of electromagnetic torque.

Two scaling blocks are used in efficiency controller. Block IS is used for normalization of input variable, so same controller can be used for a different power range of machine. Block OS is used for output scaling to adjust influence of torque reserve in determination of  $i_{dLMC}^*$  and obtain requested compromise between power loss reduction and good dynamic response.

#### 4.7 Search methods using neural networks

To find control combination that leads to the minimum power input point an artificial neural network (ANN) based search algorithm can be employed to operate as an efficiency optimizer. One typical ANN search control block applied for direct torque controlled IMD is presented in fig. 10 (Chis et al., 1997). Also, similar method can be applied for vector controlled IMD (Prymak et al., 2002)

Input drive power is measured and difference between two successive steps is calculated. Result  $\Delta P_{in}(k)$  is one input variable in artificial neural network. It is scaled to the normalized interval [0 1] in input scaling block IS. Second input variable is last step of stator flux  $\Delta \Psi_s(k-1)$ . The neural networks has two inputs, one output, and two hidden layers, of 4 and 2 neurons respectively. The training was done off-line, by connecting the ANN in parallel with an adaptive step minimum search system. Output variable of efficiency controller is

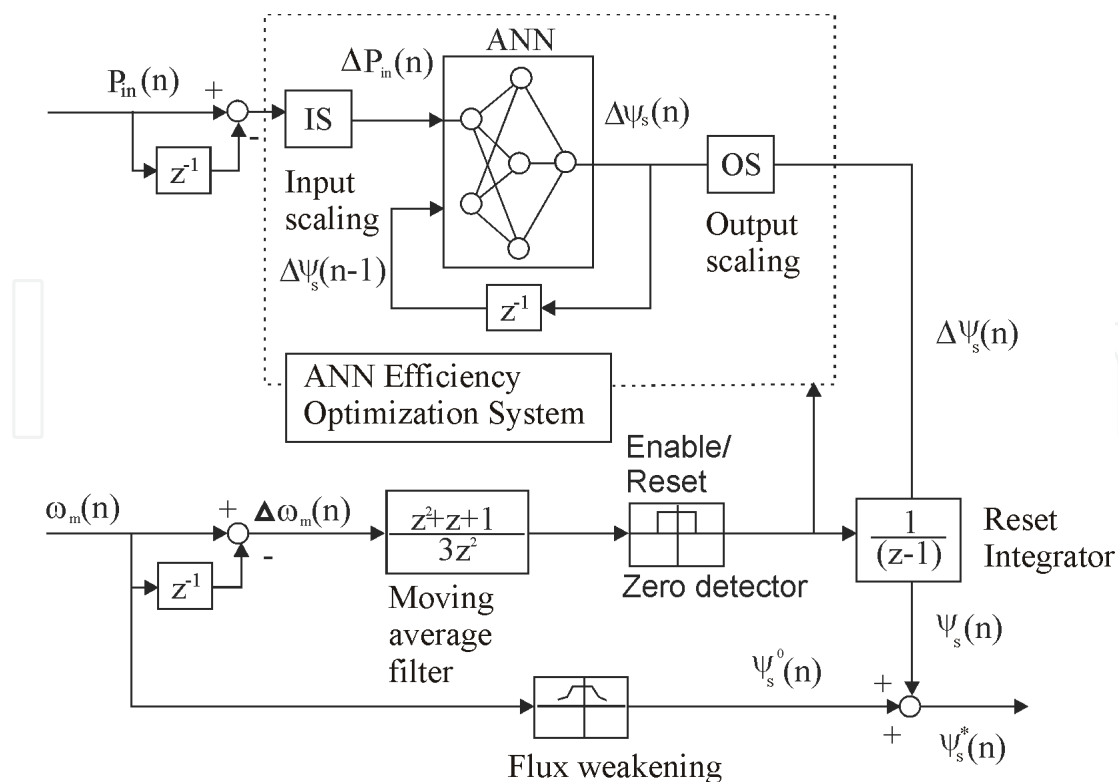

Fig. 10. ANN efficiency optimizer

new step of stator flux  $\Delta\Psi_s(n)$ . Also, it is normalized to interval  $[-1,1]$  and its scaling to real value is implemented in output scaling (OS) block.

Steady state of the system is detected in second part of efficiency optimization block which input is mechanical speed  $\omega_m(n)$ . If steady state is detected optimization block is enabled and output is  $\Psi_s^*(n)=\Psi_s(n)$ . Adversely, flux is set to the value given by flux weakening block and  $\Psi_s^*(n)=\Psi_s^0(n)$

## 5. Efficiency optimization of closed cycle operation IMD

Efficiency improvement of *IMD* based on dynamic programming (optimal flux control) is an interesting solution for closed-cycle operation of drives (Lorenz & Yang, 1992). For these drives, it is possible to compute optimal control, so the energy consumption for one operational cycle is minimized. In order to do that, it is necessary to define performance index, system equations and constraints for control and state variables and present them in a form suitable for computer processing.

The performance index is as follows (Bellman, 1957), (Brayson, 1975):

$$J = \phi[x(N)] + \sum_{n=1}^{N-1} L(x(n), u(n)) \quad (18)$$

where  $N=T/T_s$ ,  $T$  is a period of close-cycled operation and  $T_s$  is sample time. The  $L$  function is a scalar function of  $x$ -state variables and  $u$ -control variables, where  $x(n)$ , a sequence of  $n$ -vector, is determined by  $u(n)$ , a sequence of  $m$ -vector. The  $\phi$  function is a function of state variables in the final stage of the cycle. It is necessary for a correct definition of performance index.

The system equations are:

$$x(n+1) = f[x(n), u(n)], n = 0..N-1, \quad (19)$$

and  $f$  can be a linear or nonlinear function. Functions  $L$  and  $f$  must have first and second derivation on its domain.

The constraints of the control and state variables in terms of equality and inequality are:

$$C[x(n), u(n)] \leq 0, \quad i = 0, 1, \dots, N-1. \quad (20)$$

Following the above mentioned procedure, performance index, system equations, constraints and boundary conditions for a vector controlled *IMD* in the rotor flux oriented reference frame, can be defined as follows:

a. The performance index is (Vukosavic & Levi, 2003), (Blanusa et al. 2006):

$$J = \sum_{n=0}^{N-1} \left[ ai_d^2(n) + bi_q^2(n) + c_1\omega_e(n)\psi_D^2(n) + c_2\omega_e^2(n)\psi_D^2(n) \right], \quad (21)$$

Rotor speed  $\omega_r$  and electromagnetic torque  $T_{em}$  are defined by operating conditions (speed reference, load and friction).

b. The dynamics of the rotor flux can be described by the following equation:

$$\psi_D(n+1) = \psi_D(n) \left( 1 - \frac{T_s}{T_r} \right) + \frac{T_s}{T_r} L_m i_d(n), \quad (22)$$

where  $T_r = L_r/R_r$  is a rotor time constant.

c. Constraints:

$$\begin{aligned} k i_d(n) i_q(n) &= T_{em}(n), \quad k = \frac{3}{2} \frac{p}{L_r} \frac{L_m^2}{L_r}, \quad (\text{for torque}) \\ i_d^2(n) + i_q^2(n) - I_{smax}^2 &\leq 0, \quad (\text{for stator current}) \\ -\omega_{rn} &\leq \omega_r \leq \omega_{rn}, \quad (\text{for speed}) \\ \psi_D(n) - \psi_{Dn} &\leq 0, \quad (\text{for rotor flux}) \\ \psi_{Dmin} - \psi_D(n) &\leq 0. \end{aligned} \quad (23)$$

$I_{smax}$  is maximal amplitude of stator current,  $\omega_{rn}$  is nominal rotor speed,  $p$  is number of poles and  $\psi_{Dmin}$  is minimal value of rotor flux.

Also, there are constraints on stator voltage:

$$0 \leq \sqrt{v_d^2 + v_q^2} \leq V_{smax}, \quad (24)$$

where  $v_d$  and  $v_q$  are components of stator voltage and  $V_{smax}$  is maximal amplitude of stator voltage.

Voltage constraints are more expressed in *DTC* than in field-oriented vector control.

d. Boundary conditions:

Basically, this is a boundary-value problem between two points which are defined by starting and final value of state variables:

$$\begin{aligned} \omega_r(0) &= \omega_r(N) = 0, \\ T_{em}(0) &= T_{em}(N) = 0, \\ \psi_{Dn}(0) &= \psi_{Dn}(N) = \text{free}, \\ &\text{considering constrains in (23)} \end{aligned} \quad (25)$$

Presence of state and control variables constrains generally complicates derivation of optimal control law. On the other side, these constrains reduce the range of values to be searched and simplify the size of computation (Lorenz & Yang, 1992).

Let us take the following assumptions into account:

1. There is no saturation effect ( $\psi_D \leq \psi_{Dn}$ ).
2. Supply frequency is a sum of rotor speed and slip frequency,  $\omega_k = \omega_r + \omega_s$ . Rotor speed is defined by speed reference whereas slip frequency is usually low and insignificantly influences on total power loss (Ionel et al., 2006)
3. Rotor leakage inductance is significantly lower than mutual inductance,  $L_{\sigma r} \ll L_m$ .
4. Electromagnetic torque reference and speed reference are defined by operation conditions within constraints defined in equation (23).

Following the dynamic programming theory, Hamiltonian function  $H$ , including system equations and equality constraints can be written as follows (Blanusa et al., 2008):

$$\begin{aligned}
 H(i_d, i_q, \omega_e, \psi_D) = & ai_d^2(n) + bi_q^2(n) + \\
 & c_1\omega_e(n)\psi_D^2(n) + c_2\omega_e^2(n)\psi_D^2(n) + \\
 & \lambda(n+1) \left[ \psi_D(n) \frac{T_r - T_s}{T_r} + \frac{T_s}{T_r} L_m i_d(n) \right] \\
 & + \mu(n) [ki_d(n)i_q(n) - T_{em}(n)].
 \end{aligned} \tag{26}$$

In a purpose to determine stationary state of performance index, next system of differential equations are defined:

$$\begin{aligned}
 \lambda(n) = & \lambda(n+1) \frac{T_r - T_s}{T_r} + 2(c_1\omega_e(n) + c_2\omega_e^2(n))\psi_D(n) \\
 2bi_q(n) + & \mu(n)ki_d(n) = 0 \\
 2ai_d(n) + & \mu(n)ki_q(n) + \lambda(n+1) \frac{T_s}{T_r} L_m = 0 \\
 ki_d(n)i_q(n) = & T_{em}(n), \omega_e(n) = \omega_r(n) + \frac{L_m}{T_r} \frac{i_q(n)}{\psi_D(n)} \\
 n = & 0, 1, 2, \dots, N-1,
 \end{aligned} \tag{27}$$

where  $\lambda$  and  $\mu$  are Lagrange multipliers.

By solving the system of equations (27) and including boundary conditions given in (23), we come to the following system:

$$\begin{aligned}
 2ai_d^4(n) + \lambda(n+1) \frac{T_s}{T_r} i_d^3(n) = & \frac{2b}{k^2} T_{em}^2(n) \\
 \psi_D(n) = & \frac{T_r}{T_r - T_s} \psi_D(n+1) - \frac{T_s}{T_r - T_s} L_m i_d(n) \\
 i_q(n) = & \frac{T_{em}(n)}{ki_d(n)}, \omega_e(i) = \omega_r(i) + \frac{L_m}{T_r} \frac{i_q(n)}{\psi_D(n)}, \\
 \lambda(n) = & 2(c_1\omega_e(n) + c_2\omega_e^2(n))\psi_D(n) + \lambda(n+1) \frac{T_r - T_s}{T_r} \\
 n = & 0, 1, 2, \dots, N-1.
 \end{aligned} \tag{28}$$

Every sample time values of  $\omega_r(n)$  and  $T_{em}(n)$  defined by operating conditions is used to compute the optimal control  $(i_d(n), i_q(n), n=0, \dots, N-1)$  through the iterative procedure and applying the backward procedure, from stage  $n = N-1$  down to stage  $n = 0$ . For the optimal control computation, the final value of  $\psi_D$  and  $\lambda$  have to be known. In this case,  $\psi_D(N) = \psi_{Dmin}$  and

$$\lambda(N) = \frac{\partial \varphi}{\partial \psi_D(N)} = 0. \tag{29}$$

### 5.1 Experimental results

Simulations and experiments have been performed in order to validate the proposed procedure.

The experimental tests have been performed on the setup which consists of:

- induction motor (3 MOT,  $\Delta$ 380V/Y220V, 3.7/2.12A,  $\cos\phi=0.71$ , 1400o/min, 50Hz)
- incremental encoder connected with the motor shaft,
- PC and dSPACE1102 controller board with TMS320C31
- floating point processor and peripherals,

The algorithm observed in this paper used the Matlab - Simulink software, dSPACE real-time interface and C language. Handling real-time applications is done in ControlDesk.

Some comparisons between algorithms for efficiency optimization are made through the experimental tests. Expressed problem in efficiency optimization methods are its sensitivity to step increase of load or speed reference, especially for low flux level. Therefore, speed response on step increase of load are analyzed for LMC and optimal flux control method. Torque load and speed reference for one operating cycle are shown in fig 11. Graph of power losses when nominal flux is applied and optimal flux control and one operating cycle is presented in fig. 12.

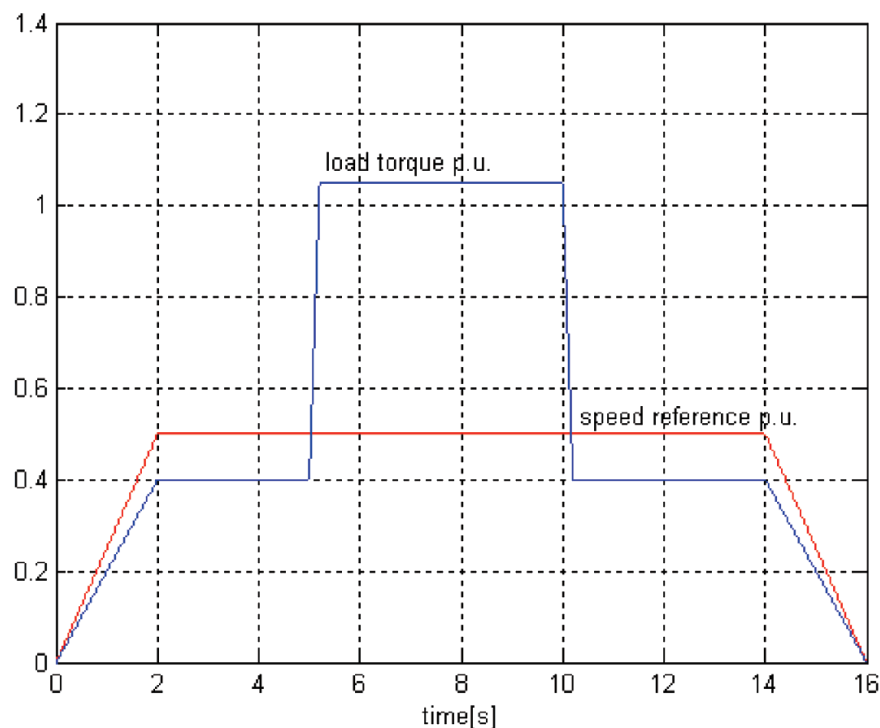

Fig. 11. Graph of speed and load torque reference in one one operating cycle.

That is obvious, for optimal flux control power loss reduction is expressed in one operating cycle

### 6. Conclusion

Algorithms for efficiency optimization of induction motor drives are briefly described. These algorithms can be applied as software solution in controlled electrical drives, particularly vector controlled and direct torque controlled IMD.



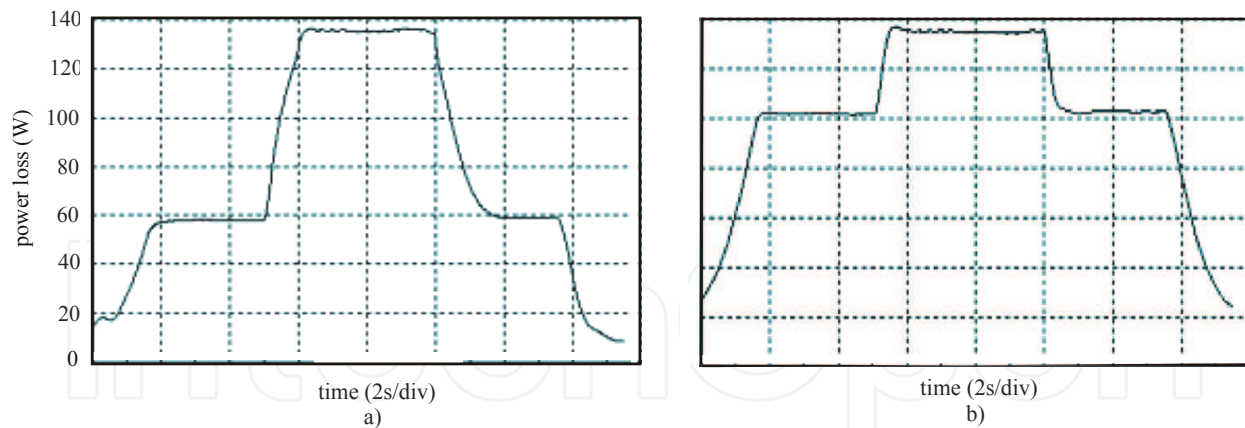

Fig. 12. Power losses in one operating cycle for a) optimal flux b) nominal flux

For a light load methods for efficiency optimization gives significant power loss reduction (Figs. 2 and 12).

Three strategies for efficiency optimization, Simple state control, Loss model control and Search control are usually used. LMC and SC are especially interested. LMC is fastest technique but very sensitive to parameter variations in loss model of drive. Also, calculation of optimal control based on loss model can be too complex. SC methods can be applied for any machine and these are insensitive to parameter variations. In many applications flux change to its optimal value is too slow. Some techniques based on fuzzy logic and artificial neural networks which obtains faster and smoothly flux convergence to the value of minimal power losses are described.

New algorithm for efficiency optimization of high performance induction motor drive and for closed-cycle operation has been proposed. Also, procedure for optimal control computation has been applied.

According to the performed simulations and experimental tests, we have arrived at the following conclusions: The obtained experimental results show that this algorithm is applicable. It offers significant loss reduction, good dynamic features and stable operation of the drive.

Some new methods for parameter identification in loss model made LMC very actual. Also, Hybrid method combines good characteristics of two optimization strategies SC and LMC were appeared. It was enhanced attention as interesting solution for efficiency optimization of controlled electrical drives. These can be very interesting for further research in this field.

## 7. Reference

- Abrahamsen F, Pedersen JK, Blaabjerg F: *State-of-Art of optimal efficiency control of low cost induction motor drives*. In: Proceedings of PESC'96, pp. 920-924, 1996
- F. Abrahamsen, F. Blaabjerg, J.K. Pedersen, P.Z. Grabowski and P. Thorgensen, " On the Energy Optimized Control of Standard and High Efficiency Induction Motors in CT and HVAC Applications", *IEEE Transaction on Industry Applications*, Vol.34, No.4, pp.822-831, 1998.
- Benbouzid M.E.H., Nait Said N.S., *An efficiency-optimization controller for induction motor drives*, *IEEE Power Engineering Review*, Vol. 18, Issue 5, pp. 63 -64, 1998.
- Bellman R., *Dynamic Programming*, Princeton University Press, 1957.

- Blanusa B., Matic P., Ivanovic Z, Vukosavic S.N.: *An Improved Loss Model Based Algorithm for Efficiency Optimization of the Induction Motor Drive*, In: Electronics (2006), Vol.10, No.1., pp. 49-52, 2006.
- Blanusa B., Slobodan N. V.: *Efficiency Optimized Control for closed-cycle Operations of High Performance Induction Motor Drive*, Journal of Electrical Engineering, Vol.8/2008-Edition: 3, pp.81-88, 2008.
- Bose B.K., Patel N.R., Rajashekara K.: *A neuro fuzzy based on-line efficiency optimization control of a stator flux oriented direct vector controlled induction motor drive*, In: IEEE Transaction on Industrial Electronics (1997), Vol. 44, No.2, pp. 270-273, 1997.
- Brayson A. E., *Applied Optimal Control, Optimization, Estimation and Control*, John Wiley & Sons, 1975.
- Chakraborty C., Ta M.C., Uchida T., Hori Y.: *Fast search controllers for efficiency maximization of induction motor drives based on DC link power measurement*. In: Proceedings of the Power Conversion Conference 2002., Vol. 2 , pp. 402 -408, 2002.
- Chis M., Jayaram S., Ramshaw R., Rajashekara K.: *Neural network based efficiency optimization of EV drive*. In: IEEE-IECIN Conference Record, pp. 454-457, 1997.
- Fernandez-Bernal F., Garcia-Cerrada A., Faure R.: *Model-based loss minimization for DC and AC vector-controlled motors including core saturation* .In: IEEE Transactions on Industry Applications, (2000), Vol. 36, No. 3, 2000, pp. 755 -763, 2000.
- Ghozzy S., Jelassi K., Roboam X.: *Energy optimization of induction motor drive*, International Conference on Industrial Technology, pp. 1662 -1669, 2004.
- Ionel D.M., Popescu M., Dellinger S.J., Miller T.J.E., Heidman R.J., McGilp M.I.: *On the variation with flux and frequency of the core loss coefficients in electrical machines*. In: IEEE Transactions on Industry Applications (2006), Vol. 42, No. 3, pp. 658-667, 2006.
- Liwei Z., Jun L., Xuhui W.: *Systematic Design of Fuzzy Logic Based Hybrid On-Line Minimum Input Power Search Control Strategy for Efficiency Optimization of IMD*, IP EMC 2006.
- Lorenz, R. D. Yang. S.-M.: *Efficiency -optimized flux trajectories for closed-cycle operation of field-orientation Induction Machine Drives*. In: IEEE Transactions on Industry Applications (1992), Vol.28, No.3, pp. 574-580, 1992.
- Prymak B., Moreno-Eguilaz J.A., Peracaula J.: *Neural network based efficiency optimization of an induction motor drive with vector control*, In: Proceedings of the IECON 02 Industrial Electronics Society, IEEE 2002 28th Annual Conference, Vol. 1, pp. 146-151, 2002.
- Sergaki E. S., Stavrakakis G.S., *Online Search Based Fuzzy Optimum Efficiency Operation in Steady and Transient States for Dc and Ac Vector Controlled Motors*, Proceedings of the 2008 International Conference on Electrical Machine, Paper ID 1190, 2008.
- Sousa D.A., Wilson C.P. de Aragao and Sousa G.C.D.: *Adaptive Fuzzy Controller for Efficiency Optimization of Induction Motors*, IEEE Transaction on Industrial Electronics, Vol. 54, No.4, pp. 2157-2164, 2007.
- Sousa G.C.D., Bose B.K., Cleland J.G.: *Fuzzy logic based on-line efficiency optimization control of an indirect vector controlled induction motor drive.*, IEEE Transaction on Industrial Electronics (1995), Vol. 42, No.2, pp. 192-198, 1995.

Uddin M.N., Nam S.W.: *Development of a nonlinear and Model Based Online Loss Minimization Control of an IM Drive*, IEEE Transaction on Energy Conversion, Vol.23, No.4, pp. 1015-1024, 2008.

Vukosavic S.N., *Controlled electrical drives - Status of technology*. In: Proceedings of XLII ETRAN Conference, Vrnjacka Banja, Yugoslavia, No. 1,pp. 3-16,1998.

Vukosavic S.N., Levi E.: *Robust DSP-based efficiency optimization of variable speed induction motor drive*, IEEE Transaction of Ind. Electronics (2003), Vol. 50, No. 3,pp. 560-570, 2003

IntechOpen

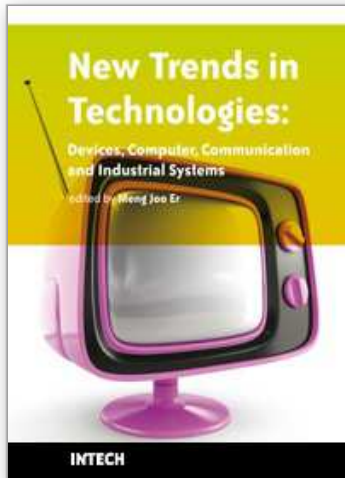

## **New Trends in Technologies: Devices, Computer, Communication and Industrial Systems**

Edited by Meng Joo Er

ISBN 978-953-307-212-8

Hard cover, 444 pages

**Publisher** Sciyo

**Published online** 02, November, 2010

**Published in print edition** November, 2010

The grandest accomplishments of engineering took place in the twentieth century. The widespread development and distribution of electricity and clean water, automobiles and airplanes, radio and television, spacecraft and lasers, antibiotics and medical imaging, computers and the Internet are just some of the highlights from a century in which engineering revolutionized and improved virtually every aspect of human life. In this book, the authors provide a glimpse of new trends in technologies pertaining to devices, computers, communications and industrial systems.

### **How to reference**

In order to correctly reference this scholarly work, feel free to copy and paste the following:

Branko Blanusa (2010). New Trends in Efficiency Optimization of Induction Motor Drives, New Trends in Technologies: Devices, Computer, Communication and Industrial Systems, Meng Joo Er (Ed.), ISBN: 978-953-307-212-8, InTech, Available from: <http://www.intechopen.com/books/new-trends-in-technologies--devices--computer--communication-and-industrial-systems/new-trends-in-efficiency-optimization-of-induction-motor-drives>

**INTECH**  
open science | open minds

### **InTech Europe**

University Campus STeP Ri  
Slavka Krautzeka 83/A  
51000 Rijeka, Croatia  
Phone: +385 (51) 770 447  
Fax: +385 (51) 686 166  
[www.intechopen.com](http://www.intechopen.com)

### **InTech China**

Unit 405, Office Block, Hotel Equatorial Shanghai  
No.65, Yan An Road (West), Shanghai, 200040, China  
中国上海市延安西路65号上海国际贵都大饭店办公楼405单元  
Phone: +86-21-62489820  
Fax: +86-21-62489821

© 2010 The Author(s). Licensee IntechOpen. This chapter is distributed under the terms of the [Creative Commons Attribution-NonCommercial-ShareAlike-3.0 License](#), which permits use, distribution and reproduction for non-commercial purposes, provided the original is properly cited and derivative works building on this content are distributed under the same license.

IntechOpen

IntechOpen