

We are IntechOpen, the world's leading publisher of Open Access books Built by scientists, for scientists

4,800

Open access books available

122,000

International authors and editors

135M

Downloads

Our authors are among the

154

Countries delivered to

TOP 1%

most cited scientists

12.2%

Contributors from top 500 universities



WEB OF SCIENCE™

Selection of our books indexed in the Book Citation Index
in Web of Science™ Core Collection (BKCI)

Interested in publishing with us?
Contact book.department@intechopen.com

Numbers displayed above are based on latest data collected.

For more information visit www.intechopen.com



Minimum Data Acquisition Time for Prediction of Periodical Variable Structure System

Branislav Dobrucký, Mariana Marčoková and Michal Pokorný
University of Zilina
Slovak Republic

1. Introduction

The term of data acquisition can be meant as 'long-term' acquisition of integral data (maximum-, average-, and root-mean-square values) sampled in order of hundred milliseconds up to seconds. Another meaning is 'on-line' data acquisition for real time control with data sampled in hundred microseconds. The goal of this work is to obtain (determine) necessary sample of acquired data at shortest minimum time. The chapter of the work deals with specific utilisation of data acquisition for identification and prediction of transient behaviour of power electronic systems.

Transients in dynamic systems are originated by changes of energetic state of state variables of accumulation elements (in electrical systems: chokes' currents and capacitors' voltages). Their duration is of non-zero time in every case, as the instant change of energetic state of accumulation elements would require infinite power. Duration of transients is theoretically infinite, except the cases when the transient phenomenon does not occur in the system at all (connection of inductive load at the instant of time equal to current phase angle in steady state). Time behaviour of state variables in linear systems is given by actual values of all elements in the system. **State variables time behaviour and thus also system response in inverter systems depends as well on sequence of switching elements operation.** Later on, the paper analyses systems with periodically variable structure (e.g. in Fig. 1).

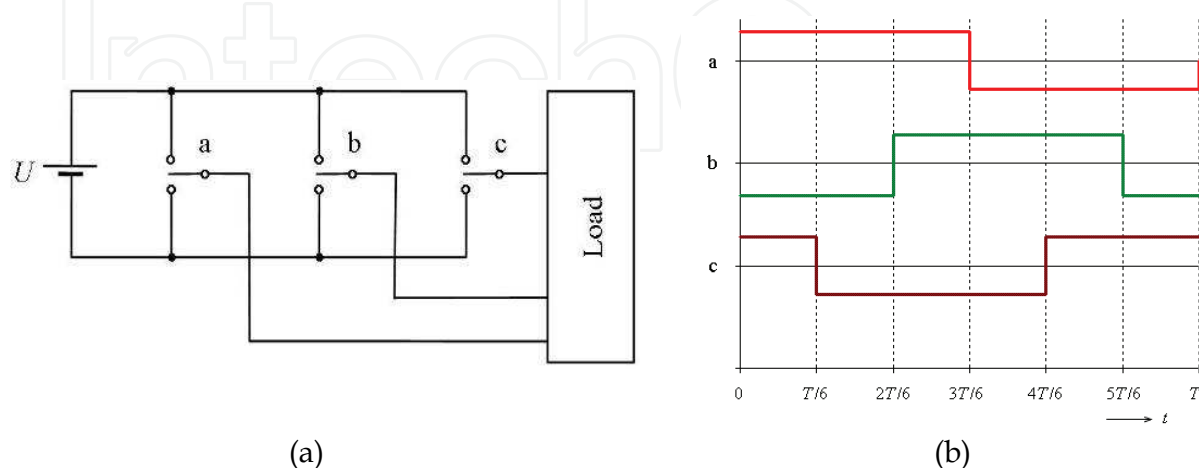

Fig. 1. Three-phase inverter system as periodically variable structure (simplified model (a) and sequence of switching (b))

It is known that state variables can reach values during transients that are even multiple of their nominal values. That is one of the reasons why it is useful and desirable to know and predict these values in advance, using appropriate mathematic apparatus.

Majority of published papers dealing with discrete representation of desired quantities for transients' analysis at given time interval use methods based on sequential insertion of values gained in preceeding interval ([Dahlquist & Bjork, 1974, Cigree, 2007, etc.]). Thus these values have to be known in advance. To speed up computation, the calculations are frequently performed in Gauss plane in orthogonal coordinates (α, β) using linear orthogonal Park-Clarke transform ([Jardan & Devan, 1969, Solik et al., 1990]). Method of prediction of the transient solution of periodical variable structure presented in the chapter is explained for the systems under periodic non-harmonic supply. It allows determination of values of desired quantities in any time instant and in any time interval, having only knowledge of situation during the first $1/2m$ -th of the time period where m is number of phases.

2. Methods for steady-state and transient behaviour determination

It is useful to accomplish description of linear dynamic system in state space in the form

$$\frac{d}{dt}(\mathbf{x}(t)) = \mathbf{A} \cdot \mathbf{x}(t) + \mathbf{B} \cdot \mathbf{u}(t) \quad (1)$$

where:

$\mathbf{x}(t)$ is the vector of state variables,

\mathbf{A}, \mathbf{B} matrices of system elements,

$\mathbf{u}(t)$ input vector of exciting functions

and also for other analysed variables in the form

$$\mathbf{y}(t) = \mathbf{C} \cdot \mathbf{x}(t) + \sum_{i=0}^r [\mathbf{D} \cdot \mathbf{u}^{(i)}(t)] \quad (2)$$

where:

$\mathbf{y}(t)$ is the vector of output variables,

\mathbf{C}, \mathbf{D} system matrices,

r highest order of derivatives of the input vector (providing the derivatives exist).

The solution for state variables can be analytical one, accomplished in time domain, e.g. using constant variation method or using convolution theorem, or numerical ([Dahlquist et al, 1974]), using time discretisation of (1)

$$\mathbf{x}_{n+1} = \mathbf{F}_n \cdot \mathbf{x}_n + \mathbf{G}_n \cdot \mathbf{u}_n \quad (3)$$

There are a number of methods to accomplish above mentioned task; they are sufficiently explained in the literature. The only remark can be pointed out: for non-linear system with time constants of various orders (stiff system) the discretisation methods of higher orders are characterised by non-permissible residual errors; thus the methods can only be used for equations up to the second order [Dahlquist & Bjork, 1974]. The advantage is to have matrices \mathbf{F}_n and \mathbf{G}_n stationary ones - they do not have to be calculated in each computational step. Non-stationary matrixes' elements can be transferred into the input vectors of exciting functions as fictitious exciting ones. Repeated calculations of matrixes \mathbf{F}_n and \mathbf{G}_n is then

necessary in case of changes of integration step only. It is more convenient to use methods for discretisation where state transient matrix $\exp(A \cdot t)$ can be expressed in semi-symbolic form using numerical technique [Mann, 1982]. Unlike the expansion of the matrix into Taylor series these methods need a (numerical) calculation of characteristic numbers and their feature is the calculation with negligible residual errors.

So, if the linear system is under investigation, its behaviour during transients can be predicted. This is not possible or sufficient for linearised systems with periodically variable structure.

Although the use of numerical solution methods and computer simulation is very convenient, some disadvantages have to be noticed:

- system behaviour nor local extremes of analysed behaviours can not be determined in advance,
- the calculation can not be accomplished in arbitrary time instant as the final values of the variables from the previous time interval have to be known,
- the calculations have to be performed since the beginning of the change up to the steady state,
- very small integration step has to be employed taking numerical (non-)stability into account; it means the step of about 10^{-6} s for the stiff systems with determinant of very low value.

It follows that system solution for desired time interval lasts for a relatively long time. The whole calculation has to be repeated for many times for system parameters changes and for the optimisation processes. This could be unsuitable when time is an important aspect. That is why a method eliminating mentioned disadvantages using simple mathematics is introduced in the following sections.

2.1 Analytical method of a transient component separation under periodic non-harmonic supply

Linear dynamic systems responses can also be decomposed into transient and steady-state components of a solution [Mayer et al., 1978, Mann, 1982]

$$\mathbf{x}(t) = \mathbf{x}_p(t) + \mathbf{x}_u(t) \quad (4)$$

The transient component of the response in absolutely stable systems is, according to the assumptions, fading out for increasing time. For invariable input $\mathbf{u}(t) = \mathbf{u}_k$ there is no difficulty in calculating a steady-state value of a state response as a limit case of equation (8) solution for $t = \infty$.

$$\mathbf{x}_u(t) = \lim_{t \rightarrow \infty} \left\{ \exp(\mathbf{A} \cdot t) \cdot \mathbf{x}_0(t) + \int_0^t \exp[\mathbf{A} \cdot (t - \tau)] \cdot d\tau \cdot \mathbf{B} \cdot \mathbf{u}_k \right\} \quad (5)$$

For steady state component of state response $\mathbf{x}_T(t)$ with the period of T the following must be valid for any t

$$\mathbf{x}_T(t) = \mathbf{x}_T(t + T) = \exp(\mathbf{A} \cdot T) \cdot \mathbf{x}_T(t) + \int_t^{t+T} \exp[\mathbf{A} \cdot (t + T - \tau)] \cdot \mathbf{B} \cdot \mathbf{u}_T(\tau) \cdot d\tau \quad (6)$$

Steady-state component for one period is then obtained from overall solution

$$\mathbf{x}_{Tu}(t) = \mathbf{x}_T(t) - \mathbf{x}_p(t) \quad (7)$$

Time behaviour in the subsequent time periods is obtained by summing transient and steady-state components of state response.

But, if it is possible to accomplish a separation of transient component from the total result, an opposite technique can be applied: steady state component is to be acquired from the waveform of overall solution for one time-period with transient component subtracted. Investigation can be conveniently performed in Laplace s-domain [Beerends et al, 2003]. If Laplace transform is used, the state response in s-domain will be

$$\mathbf{X}(s) = \frac{\mathbf{U}_T(s)}{1 - \exp(-sT)} \cdot \frac{\mathbf{K}(s)}{H(s)} \quad (6)$$

where:

$\mathbf{X}(s)$ is the Laplace image of state vector,

$K(s), H(s)$ polynomials of nominator and denominator, respectively,

$\mathbf{U}(s)$ is the Laplace image of input vector of exciting functions.

General solution in time domain is

$$\mathbf{x}(t) = \mathcal{L}^{-1} \left\{ \frac{\mathbf{K}(s)}{H(s)} \right\} = \mathcal{L}^{-1} \left\{ \frac{a_n \cdot s^n + \dots a_0 \cdot s^0}{b_n \cdot s^n + \dots b_0 \cdot s^0} \right\} \quad (7)$$

Transient component of the solution will be obtained by inverse Laplace transform of the following equation

$$\mathbf{x}_p(t) = \frac{\mathbf{K}(0)}{H(0)} + \sum_{k=1}^n \left[\frac{\mathbf{u}_T(t)}{1 - \exp(-sT)} \cdot \frac{\mathbf{K}(\lambda_k)}{\lambda_k \cdot H'(\lambda_k)} \cdot \exp(\lambda_k \cdot t) \right] \quad (8)$$

where:

λ_k are roots (poles) of denominator.

As the transient component can be separated from the overall solution, the solution is similar to the solution of D.C. circuits and there is no need to determine initial conditions at the beginning of each time period. Note: The state response can only be calculated for a half-period in A.C. symmetrical systems; then

$$\mathbf{U}(s) = \frac{\mathbf{U}_T(s)}{1 + \exp\left(-s \cdot \frac{T}{2}\right)} \quad (9)$$

The time-shape of transient components need not be a monotonously decreasing one (as can be expected). It is relative to the order of the investigated system as well as to the time-shape of the input exciting function.

Usually, it is difficult to formulate periodical function $u_T(t)$ in the form suitable for integration. In this case the system solution using Z-transform is more convenient.

2.2 System with periodic variable structure modelling using Z-transform

The following equation can be written when Z-transform is applied to difference discrete state model (3)

$$z \cdot \mathbf{X}^*(z) = \mathbf{F}_{(T/2m)}^* \cdot \mathbf{X}^*(z) + \mathbf{G}_{(T/2m)}^* \cdot \mathbf{U}^*(z) \quad (10)$$

so the required Z-transform of state vector in z-domain is

$$\mathbf{X}^*(z) = \left[z \cdot \mathbf{E}^* - \mathbf{F}_{(T/2m)}^* \right]^{-1} \cdot \mathbf{G}_{(T/2m)}^* \cdot \mathbf{U}^*(z) = \frac{\mathbf{K}(z)}{\mathbf{H}(z)} \quad (11)$$

Solving this equation (11) an image of system in dynamic state behaviour is obtained. Some problems can occur in formulation of transform exciting function $\mathbf{U}^*(z)$ with $n \cdot T/2m$ periodicity (an example for rectangular impulse functions is shown later on, in Section 3 and 4).

Solution - transition to the time domain - can be accomplished analytically by evaluating zeros of characteristic polynomial and by Laurent transform [Moravcik, 2002]

$$\mathbf{x}(t) = \mathcal{Z}^{-1} \left\{ \frac{\mathbf{K}(z)}{\mathbf{H}(z)} \right\} = \mathcal{Z}^{-1} \left\{ \frac{a_n \cdot z^n + \dots a_0 \cdot z^0}{b_n \cdot z^n + \dots b_0 \cdot z^0} \right\} \quad (12)$$

Using finite value theorem system's steady state is obtained, i.e. steady state values of the curves in discrete time instants $n \cdot T/2m$, what is purely numerical operation, easily executable by computer

$$\mathbf{x}_{\text{ust}} \left(\frac{T}{2 \cdot m} \right) = \lim_{z \rightarrow 1} \left\{ (z-1) \left[z \cdot \mathbf{E}^* - \mathbf{F}_{(T/2m)}^* \right]^{-1} \cdot \mathbf{G}_{(T/2m)}^* \cdot \mathbf{U}^*(z) \right\} \quad (13)$$

Input exciting voltages can be expressed as switching pulse function which are simply obtained from the voltages [Dobrucky *et al.*, 2007, 2009a], e.g. for output three-phase voltage of the inverter (Fig. 2)

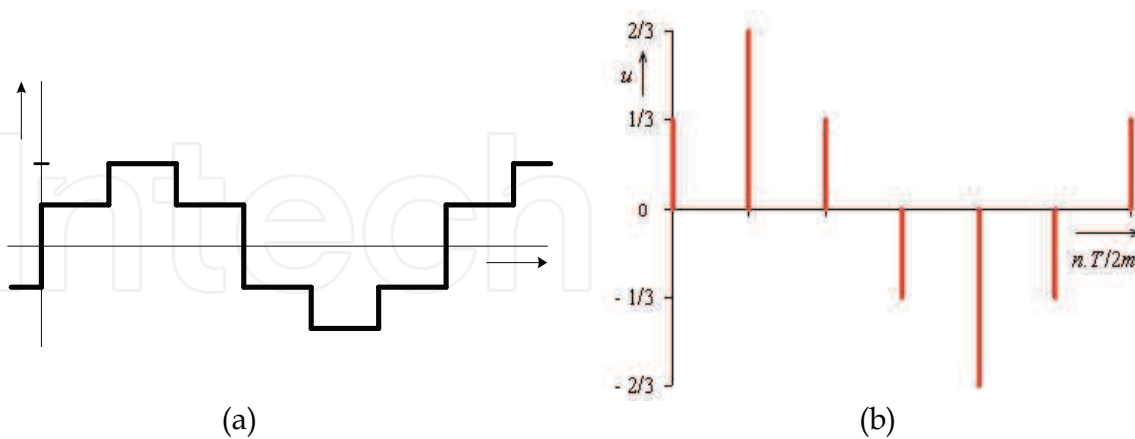

Fig. 2. Three-phase voltage of the inverter (a) and corresponding switching function (b) where three-phase voltage of the inverter can be expressed as

$$u(t) = \frac{2}{3} \cdot \sin \left(\text{int} \left(6 \cdot f \cdot t \right) \frac{\pi}{3} + \frac{\pi}{6} \right) \cdot U \quad (14)$$

or as switching function

$$u(n) = \frac{2}{3} \cdot \sin\left(\frac{n \cdot \pi}{3} + \frac{\pi}{6}\right) \cdot U \quad (15)$$

and finally as image in z-domain

$$U(z) = \frac{U}{3} \cdot \frac{z^3 + z^2 + z}{z^3 + 1} = \frac{U}{3} \cdot \frac{z \cdot (z+1)}{z^2 - z + 1} \quad (16)$$

3. Minimum necessary data sample acquisition

The question is: How much data acquisition and for how long acquisition time? It depends on symmetry of input exciting function of the system.

3.1 Determined periodical exciting function (supply voltage) and linear constant load system (with any symmetry)

Principal system response is depicted in Fig. 3

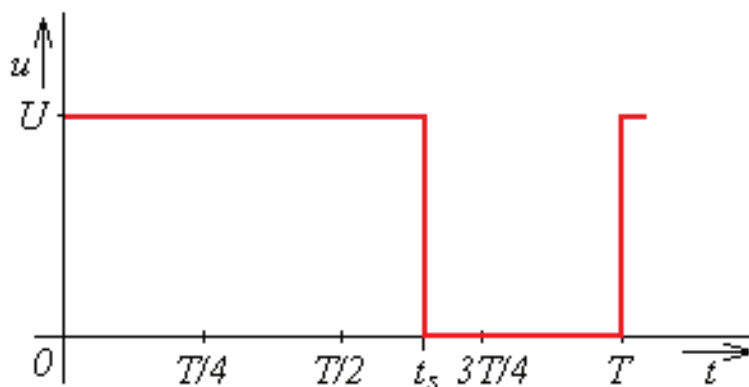

Fig. 3. Periodical non-harmonic voltage (red) without symmetry

In such a case one needs one time period for acquired data with sampling interval Δt given by Shannon-Kotelnikov theorem. Practically sampling interval should be less than 1 el. degree. Then number of samples is 360-720 as decimal number or 512-1024 expressed as binary number.

3.2 Determined periodical exciting function (supply voltage) and linear constant load system with $T/2$ symmetry

Contrary to the previous case one needs one half of time period for acquired data with sampling interval Δt given by Shannon-Kotelnikov theorem. Practically sampling interval should be less than 1 el. degree. Then number of samples is 180-360 as decimal number or 256-512 expressed as binary number.

Principal system response is depicted in Fig. 4.

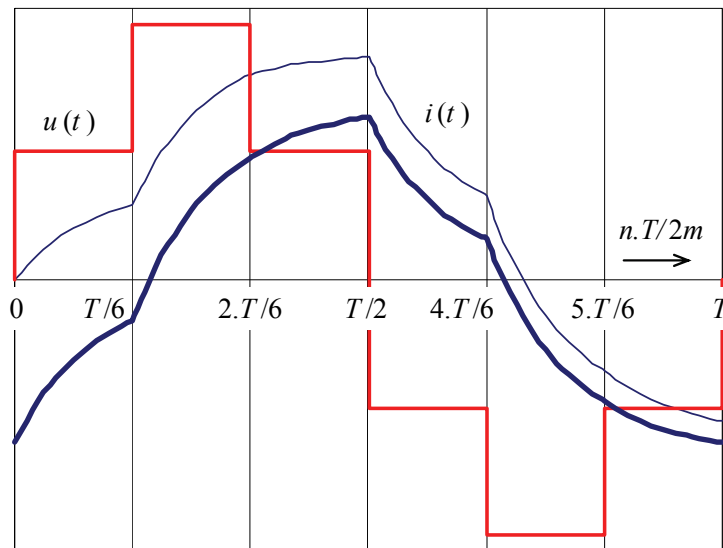

Fig. 4. Periodical non-harmonic voltage with $T/2$ symmetry (red) and current response under R - L load in steady (dark blue)- and transient (light blue) states

3.3 Determined periodical exciting function (supply voltage) and linear constant load system with $T/6$ ($T/4$) symmetry using Park-Clarke transform

System response is depicted in Fig. 5a for three-phase and Fig. 5b for single-phase system.

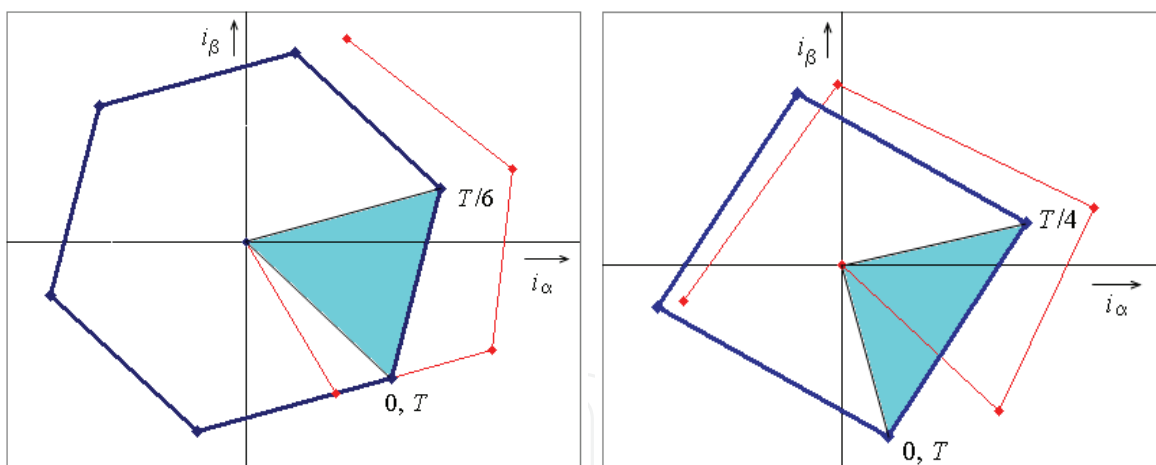

Fig. 5. Transient (red)- and steady-state (blue) current response under R - L load using Park-Clarke transform with $T/6$ ($T/4$) symmetry

In such a case of symmetrical three-phase system the system response is presented by six-side symmetry. Then one need one sixth of time period for acquired data with sampling interval Δt given by Shannon-Kotelnikov theorem. Practically sampling interval should be less than 1 el. degree. Then number of samples is 60-120 as decimal number or 64-128 expressed as binary number.

In the case of symmetrical single-phase system the system response is presented by four-side symmetry [Burger et al, 2001, Dobrucky et al, 2009]. Then one need one fourth of time

period for acquired data with sampling interval Δt given by Shannon-Kotelnikov theorem. Practically sampling interval should be better than 1 el. degree. Then number of samples is 90-180 as decimal number or 128-256 expressed as binary number. Important note: Although the acquisition time is short the data should be aquired in both channels alpha- and beta.

3.4 Determined periodical exciting function (supply voltage) and linear constant load system with $T/6$ ($T/4$) symmetry using z-transform

Principal system responses for three-phase system are depicted in Fig. 6a and for single-phase in Fig. 6b, respectively.

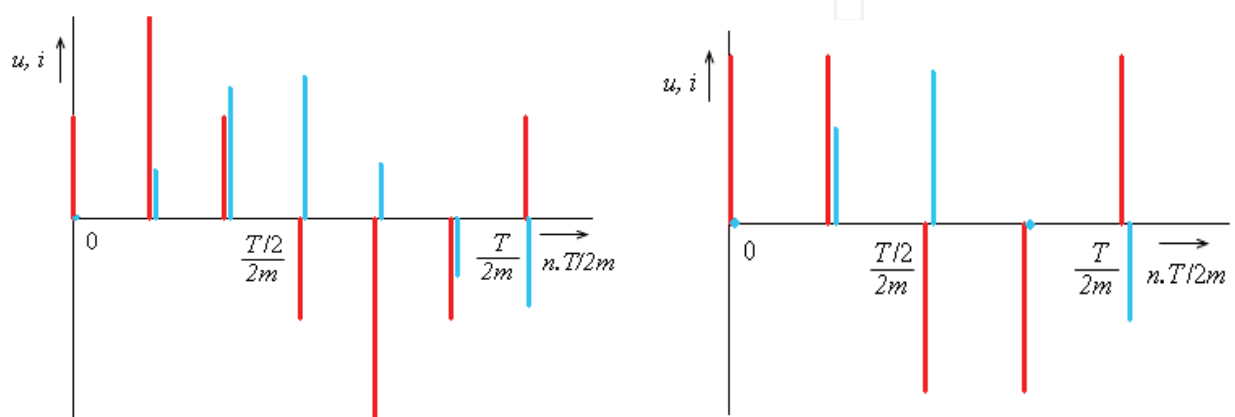

Fig. 6. Voltage (red)- and transient current response (blue) switching functions with $T/6$ ($T/4$) symmetry under R - L load using z-transform

In such a case of symmetrical three-phase system the system response is presented by six-side symmetry. Then one need one sixth of time period for acquired data with sampling interval Δt given by Shannon-Kotelnikov theorem. Practically sampling interval should be better less 1 el. degree. Then number of samples is 60-120 as decimal number or 64-128 expressed as binary number.

In the case of symmetrical single-phase system the system response is presented by four-side symmetry. Then one need one fourth of time period for acquired data with sampling interval Δt given by Shannon-Kotelnikov theorem. Practically sampling interval should be less than 1 el. degree. Then number of samples is 90-180 as decimal number or 128-256 expressed as binary number.

Note: It is sufficiently to collect the data in one channel (one phase).

3.5 Determined periodical exciting function (supply voltage) and linear constant load system with $T/2m$ symmetry using z-transform

System response is depicted in Fig. 7.

The wanted wave-form is possible to obtain from carried out data using polynomial interpolation (e.g. [Cigre, 2007, Prikopova et al, 2007]). In such a case theoretically is possible to calculate requested functions in $T/6$ or $T/4$ from three measured point of Δt . However, the calculation will be paid by rather inaccuracy due to uncertainty of the measurement for such a short time.

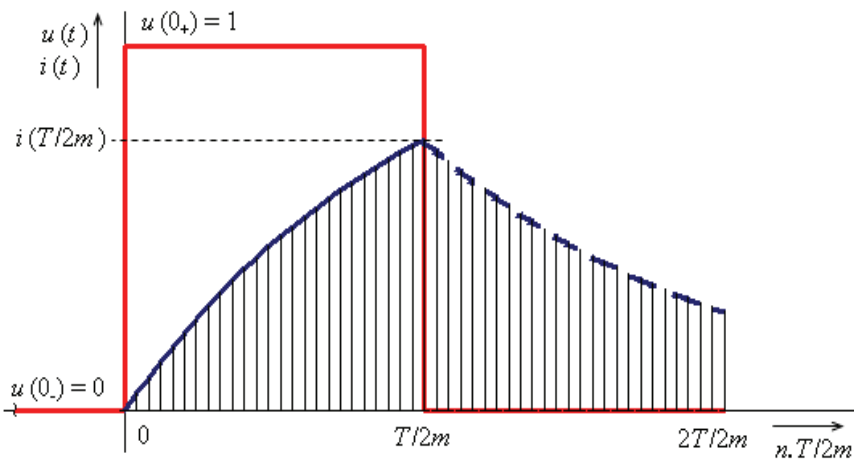

Fig. 7. Transient current response on voltage pulse with $T/2m$ symmetry under $R-L$ load

4. Modelling of transients of the systems

4.1 Modelling of current response of three-phase system with $R-L$ constant load and $T/6$ symmetry using z-transform

Let's consider exciting switching function of the system in α, β - coordinates

$$u_\alpha(n) = \frac{2}{3} \cdot \sin\left(\frac{n \cdot \pi}{3} + \frac{\pi}{6}\right) \cdot U \tag{18a}$$

$$u_\beta(n) = \frac{-2}{3} \cdot \cos\left(\frac{n \cdot \pi}{3} + \frac{\pi}{6}\right) \cdot U \tag{18b}$$

where n is n -th multiply of $T/2m$ symmetry term (for 3-phase system equal $T/6$).

The current responses in α, β - coordinates are given as

$$i_\alpha(n+1) = f_{T/6} \cdot i_\alpha(n) + g_{T/6} \cdot u_\alpha(n) \tag{19a}$$

$$i_\beta(n+1) = f_{T/6} \cdot i_\beta(n) + g_{T/6} \cdot u_\beta(n) \tag{19b}$$

where $f_{T/6}$ and $g_{T/6}$ terms are actual values of state-variables i.e. currents at the time instant $t=T/6$, Fig. 8, which can be obtained by means of data acquisition or by calculation.

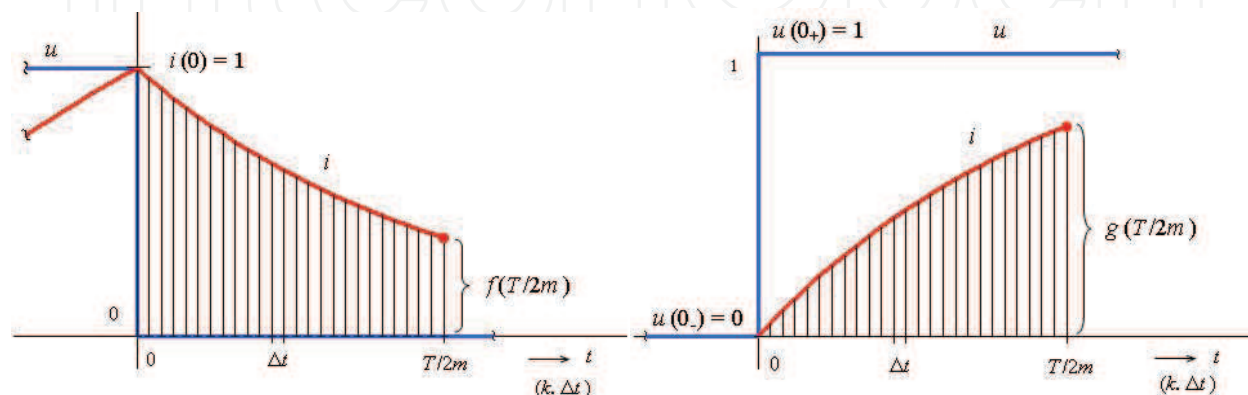

Fig. 8 Definition of the $f_{T/6}$ and $g_{T/6}$ terms for current in α - or β - time coordinates

Knowing these $f_{T/6}$ and $g_{T/6}$ terms one can calculate transient state using iterative method on relations for the currents (19a) and (19b), respectively. For non-iterative analytical solution is very useful to use z - and inverse z -transform consequently.

4.2 Determination of $f(T/2m)$ and $g(T/2m)$ by calculation

By substitution of $f(\Delta t) = 1 + \Delta t \cdot \mathbf{A}$ and $g(\Delta t) = \Delta t \cdot \mathbf{B}$ one obtains

$$i(\Delta t) = f(\Delta t) \cdot i(0) + g(\Delta t) \cdot u(0) \quad (20)$$

Based on full mathematical induction

$$i(k+1) = f(\Delta t) \cdot i(k) + g(\Delta t) \cdot u(k) \quad (21)$$

Note: $f(\Delta t)$ and $g(\Delta t)$ are the values of the functions in the instant of time $t = 1 \cdot \Delta t$, so, now it is possible to calculate above equation for k from $k = 0$ up to $k = \frac{T/2m}{\Delta t}$ having initial values $i(0) = 0$ and $u(0) = 1$.

Using transformation of equation (21) into z -domain

$$z \cdot I(z) = f(\Delta t) \cdot I(z) + g(\Delta t) \cdot U(z) + z \cdot I(0) \quad (22a)$$

$$I(z) = \frac{g(\Delta t)}{z - f(\Delta t)} \cdot U(z) + \frac{z}{z - f(\Delta t)} \cdot I(0) \quad (22b)$$

Supposing $u(k)$ to be constant then

$$I(z) = U(0) \cdot \frac{g(\Delta t)}{z - f(\Delta t)} \cdot \frac{z}{z - 1} + I(0) \cdot \frac{z}{z - f(\Delta t)} \quad (23)$$

Thus solution for $i(k)$ will be

$$\begin{aligned} i(k) &= u(0) \cdot g(\Delta t) \cdot \sum_{i=0}^k \left[\frac{1}{(z_i - f(\Delta t)) \cdot (z_i - 1)} \cdot z_i^k \right] + i(0) \cdot f^k(\Delta t) = \\ &= i(k) = u(0) \cdot \frac{g(\Delta t)}{1 - f(\Delta t)} \cdot [1^k + f^k(\Delta t)] + i(0) \cdot f^k(\Delta t) \end{aligned} \quad (24)$$

Note: It is needful to choose the integration step short enough, e.g. 1 electrical degree, regarding to numerical stability conditions [Mann, 1982].

So, if we put $u(0)=0$ and $k = \frac{T/2m}{\Delta t}$ we get $f(T/2m)$ directly

$$f(T/2m) = 0 + i(0) \cdot f^{\frac{T/2m}{\Delta t}}(\Delta t) \quad (25)$$

If we put $k = \frac{T/2m}{\Delta t}$ and $i(0) = 0$ we get $g(T/2m)$ directly (see Fig. 8)

$$g(T/2m) = u(0) \cdot \frac{g(\Delta t)}{1 - f(\Delta t)} \cdot \left[1^{\frac{T/2m}{\Delta t}} - f^{\frac{T/2m}{\Delta t}}(\Delta t) \right] + 0 \quad (26)$$

4.3 Determination of $f(T/2m)$ and $g(T/2m)$ by calculation

Using z-transform on difference equations (19a), (19b) we can obtain the image of α -component of output voltage in z-plane

$$U(z) = \frac{U}{3} \cdot \frac{z^3 + z^2 + z}{z^3 + 1} = \frac{U}{3} \cdot \frac{z \cdot (z + 1)}{z^2 - z + 1} \quad (27)$$

Then, the image of α -component of output current in z-plane is

$$I(z) = \frac{U}{3} \cdot g_{T/6} \cdot \frac{z \cdot (z + 1)}{(z - f_{T/6}) \cdot (z^2 - z + 1)} \quad (28)$$

The final notation for α -current of the 3-phase system gained by inverse transformation $I(z) \rightarrow i(nT/2m)$

$$i(n) = \frac{1}{3 \cdot R} \cdot g(T/6) \cdot \frac{1 + f(T/6)}{f^2(T/6) - f(T/6) + 1} \cdot \left[f^n(T/6) + \sqrt{3} \cdot \frac{1 - f(T/6)}{1 + f(T/6)} \cdot \sin\left(\frac{n \cdot \pi}{3}\right) - \cos\left(\frac{n \cdot \pi}{3}\right) \right] \cdot u(n) \quad (29)$$

Calculation of time-waveform in the interval between successive values $n \cdot T/2m$ and $(n+1) \cdot T/2m$

We can calculate by successive setting k into Eq. (21) starting from

$$i(k) = i(n \cdot T/2m) \text{ for } k = 0 \text{ up to } k = \frac{T/2m}{\Delta t} \quad (30)$$

Also, we can use absolute form of the series (24) with $i(0) = i(n \cdot T/2m)$, and $u(0) = u(n \cdot T/2m)$. When there is a need to know the values in arbitrary time instant within given time interval

$$i(n, k) = u(n) \cdot \frac{g(\Delta t)}{1 - f(\Delta t)} \cdot \left[1^k - f^k(\Delta t) \right] + i(n) \cdot f^k(\Delta t) \quad (31)$$

4.4 Modelling of current response of single-phase system with R - L constant load and $T/4$ symmetry using z-transform

Let's consider exciting switching function of the system in α, β coordinates

$$u_\alpha(n) = \sqrt{2} \cdot \sin\left(\frac{n \cdot \pi}{2} + \frac{\pi}{4}\right) \cdot U \quad (32a)$$

$$u_\beta(n) = -\sqrt{2} \cdot \cos\left(\frac{n \cdot \pi}{2} + \frac{\pi}{4}\right) \cdot U \quad (32a)$$

where n is n -th multiply of $T/2m$ symmetry term (for single-phase system equal $T/4$). The current responses in α, β coordinates are given as

$$i_\alpha(n+1) = f_{T/4} \cdot i_\alpha(n) + g_{T/4} \cdot u_\alpha(n) \quad (33a)$$

$$i_\beta(n+1) = f_{T/4} \cdot i_\beta(n) + g_{T/4} \cdot u_\beta(n) \quad (33b)$$

where $f_{T/4}$ and $g_{T/4}$ terms are actual values of state-variables i.e. currents at the time instant $t=T/4$.

Using z-transformation on voltage equations one can get

$$U_{\alpha}(z) = U \cdot \frac{z \cdot (z+1)}{z^2 + 1} \quad (34a)$$

$$U_{\beta}(z) = -U \cdot \frac{z \cdot (z+1)}{z^2 + 1} \quad (34b)$$

Using transformation of equation (21) into z-domain

$$I_{\alpha}(z) = \frac{g_{T/4}}{z - f_{T/4}} \cdot U_{\alpha}(z) \quad (35a)$$

$$I_{\beta}(z) = \frac{g_{T/4}}{z - f_{T/4}} \cdot U_{\beta}(z) \quad (35b)$$

The final notation for α -current of the single-phase system gained by inverse transformation $I(z) \rightarrow i(nT/2m)$

$$I_{\alpha}(n) = \frac{U}{R} g_{T/4} \frac{f_{T/4} + 1}{f_{T/4}^2 + 1} \cdot f_{T/4}^n + \frac{1 - f_{T/4}}{1 + f_{T/4}} \sin\left(n \frac{\pi}{2}\right) - \cos\left(n \frac{\pi}{2}\right) \quad (36)$$

5. Simulation experiments using acquired data

Schematic diagram for three- and single phase connection, Fig. 9.

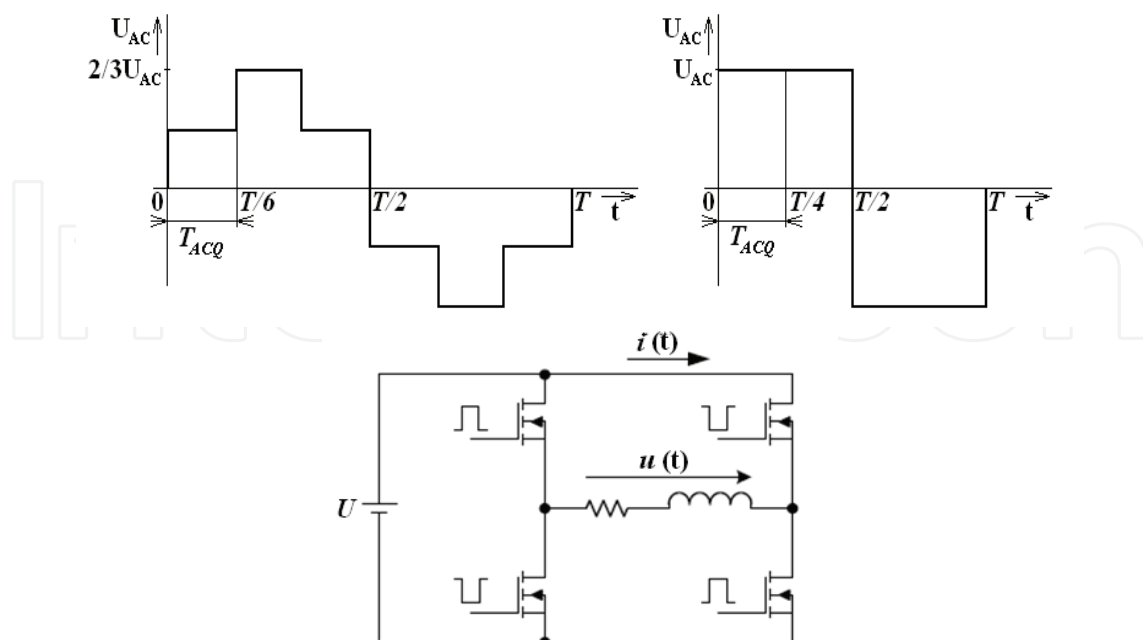

Fig. 9. Schematic diagram for three- and single phase output voltages and real connection for measurement

Equivalent circuit diagram of measured circuit is presented in Fig. 10.

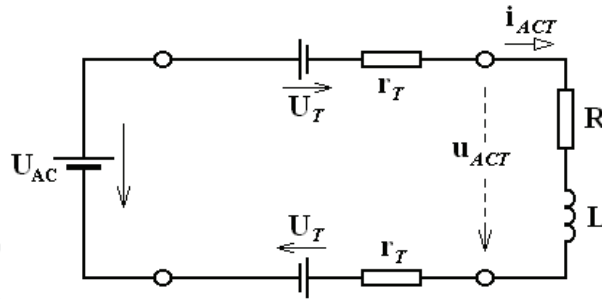

Fig. 10. Equivalent circuit diagram of measured circuit

Actual real data will be differ from calculated ones:

- other parameters, transient resistors, contact potentials, threshold voltages of the switches,
- parameters non-linearities,
- different switching due to switches inertials.

Tables of actual real values of the quantities u_{ACT} and i_{ACT} is shown bellow; Tab. 1 for determination of $g_{T/6}$ and $g_{T/4}$ terms, Tab. 2 for determination of $f_{T/6}$ and $f_{T/4}$ terms.

n	u_{ACT}	i_{ACT}	Δi
0	100,000	0,000	0,000
10	97,448	5,266	0,137
20	96,465	10,144	0,371
30	95,553	14,669	0,682
40	94,706	18,871	1,054
50	93,919	22,778	1,474
60	93,187	26,415	1,931
70	92,504	29,804	2,414
80	91,868	32,964	2,917
90	91,274	35,913	3,433

Tab. 1. Real acquired data for determination of $g_{T/6}$ and $g_{T/4}$ terms

n	i_{ACT}
0	100,000
30	84,648
60	71,653
90	60,653

Tab. 2 Real acquired data for determination of $f_{T/6}$ and $f_{T/4}$ terms

Actual carried-out date for simulation experiments are as following:

$$f_{T/6} = 1,65 \quad f_{T/4} t = 60,65$$

$$g_{T/6} = 26,41 \quad g_{T/4} t = 35,91$$

Time dependences of actual $u_{ACT}(t)$ and $i_{ACT}(t)$ are depicted in Fig. 10.

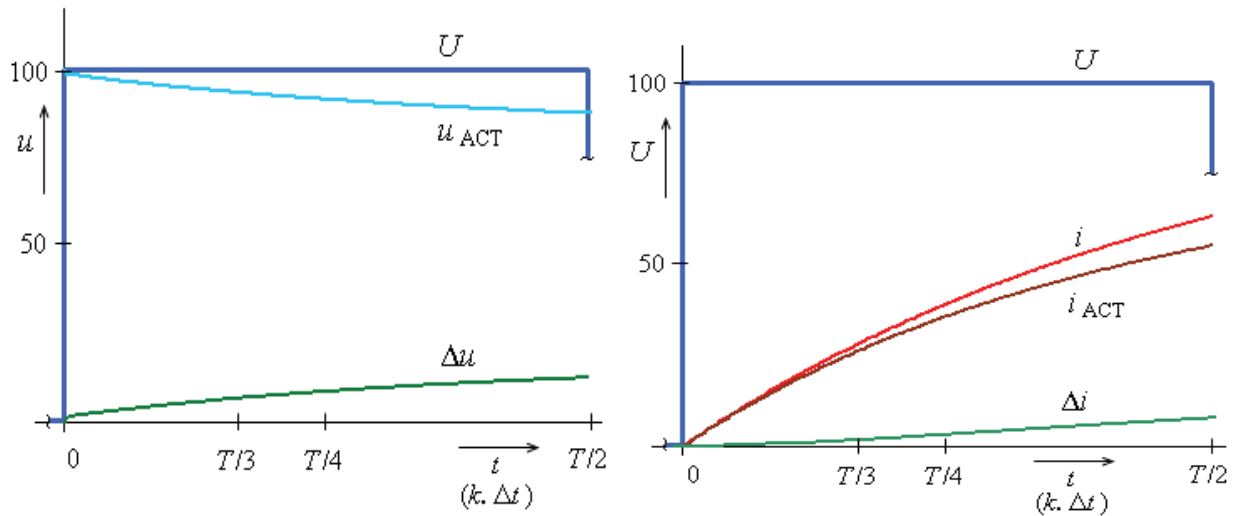

Fig. 10. Graphical comparison of actual real- and idealized calculated data of

Actually, each voltage (and/or current)-pulse should be practically shorter as idealized one from the mathematical point of view due to requested blanking time (or dead-time) T_{\square} i.e. time-space between successive switched electronic switches [Mohan *et al.*, 2003]. This is fixed set between tenths of microseconds up to microseconds, so for high switching frequencies its effect will be stronger, Fig. 11.

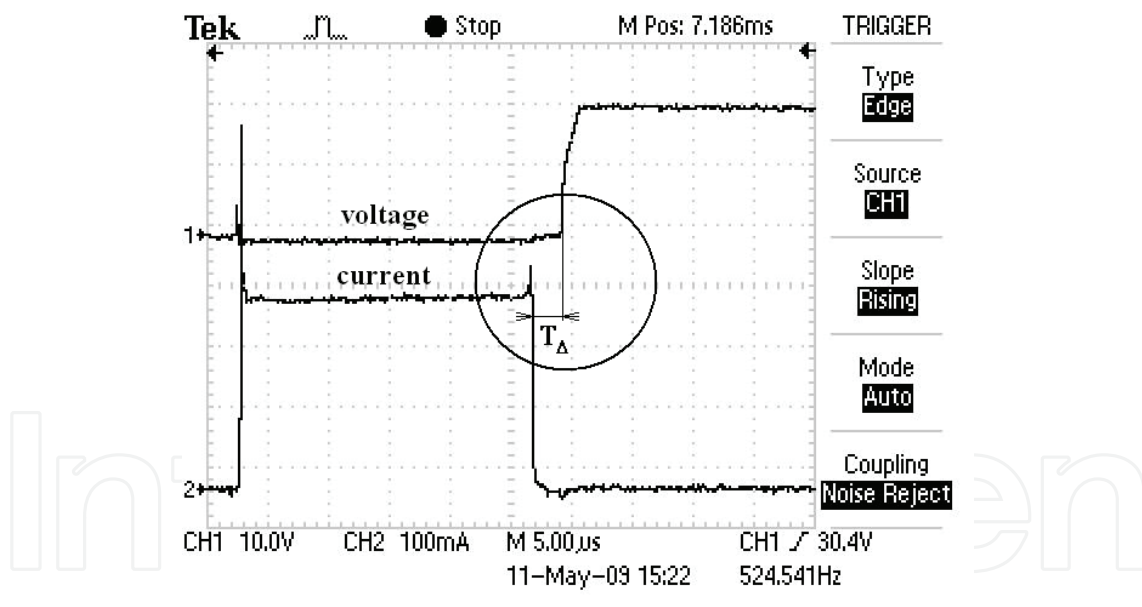

Fig. 11. Real measured blanking time at pulse width of 25 μs

Since both the complementing switches are off during blanking time, the voltage during that interval depends on the direction of the current. By averaging over one time period of the switching frequency ($f_s = 1/T_s$), the average value during T_s of the idealized waveform minus the actual waveform is

$$\Delta = +2T_{\Delta}/T_s \cdot U \text{ for } i > 0, \text{ and}$$

$$\Delta = -2T_{\Delta}/T_s \cdot U \text{ for } i < 0$$

The distortion in $u(t)$ at the current zero-crossing results in low order harmonics such as 3rd, 5th, 7th, and so on of fundamental frequency in the inverter output, that make it higher the total harmonic distortion of output quantities.

Simulation experiments will done with real actual data $f_{T/6}, f_{T/4}$ and $g_{T/6}, g_{T/4}$ using relation (29) and (36), respectively.

Carried-out results of three-phase system (Eq. 29) are shown in Fig. 12a,b both in complex and time domain.

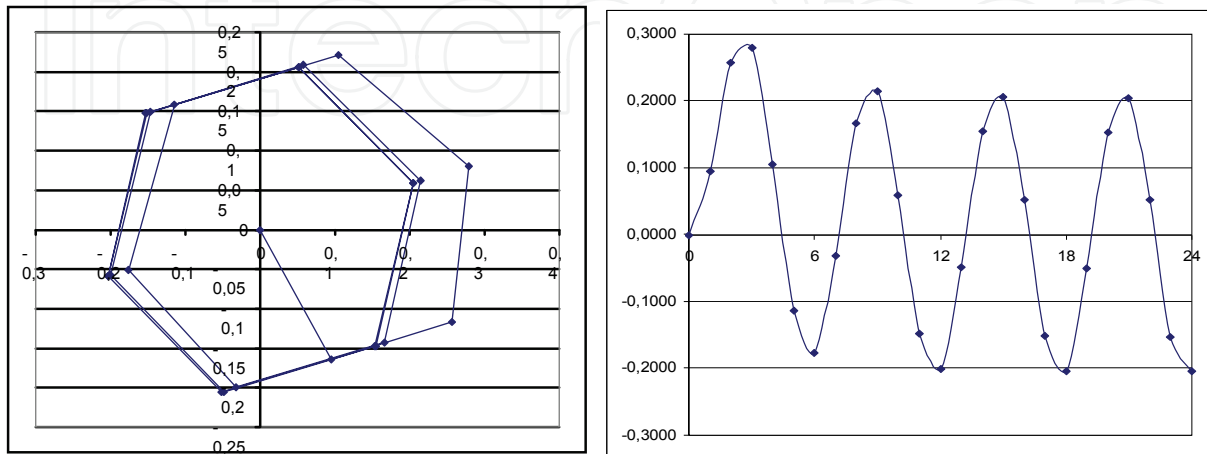

Fig. 12. a,b Trajectories of 3-phase system quantities in complex (left) and time domain (right)

Carried-out results of single-phase system (Eq. 36) are depicted in Fig. 13a,b both in complex and time domain.

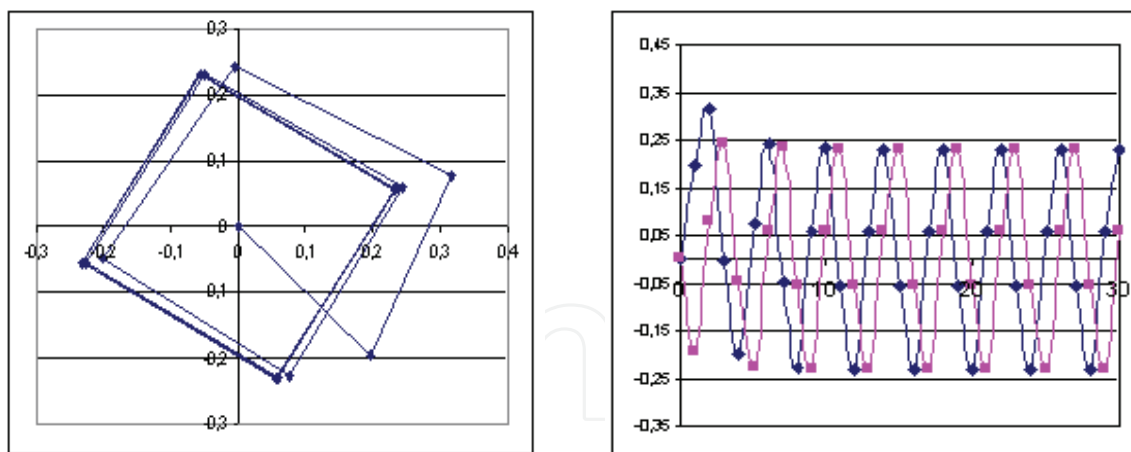

Fig. 13. a,b Trajectories of output voltage in complex (left) and time domain (right)

6. Evaluation and conclusion

A new method is introduced, which allows predicting and calculating behaviour of the system during dynamic states as e.g. switching on/off, load changes, etc. from the data obtained for one $2m$ -th of time period. If impulse exciting function can be expressed with higher periodicity, e.g. $nT/12, nT/18$ etc., prediction of transients can be accomplished from the data gained even in shorter time interval, i.e. $T/12, T/18$ etc., respectively. Information

about these transient states is needful for precise dimensioning of system's elements and for fair and reliable operation of the system.

7. References

- Beerends, R.J., Morsche, H.G., van den Berg, J.C. & van de Vrie, E.M. (2003). *Fourier and Laplace Transforms*, Cambridge University Press, Cambridge.
- Burger, B. & Engler, A. (2001). Fast signal conditioning in single phase systems. *Proc. of 9th European Conference on Power Electronics and Applications*, pp. CD-ROM, ISBN 90-75815-06-9, Graz (AT), August 2001
- CIGRE Working Group (2007). *C4.601 Modeling and Dynamic Behavior of Wind Generation Relates to Power System Control and Dynamic Performance*, CIGRE, August 2007,
- Dahlquist, G. & Bjork, A. (1974). *Numerical Methods*, Prentice-Hall, New York, USA
- Dobrucky, B., Pokorny M. & Benova, M. (2009a). *Interaction of Renewable Energy Sources and Power Supply Network*, in book *Renewable Energy*, In-Teh Publisher, ISBN 978-953-7619-52-7, Vukovar (CR), pp. 197-210
- Dobrucky, B., Benova, M. & Pokorny M. (2009b). Using Virtual Two Phase Theory for Instantaneous Single-Phase Power System Demonstration. *Electrical Review / Przegląd Elektrotechniczny (PL)*, Vol. 85, No. 1, Jan. 2009, pp. 174-178, ISSN 0033-2097
- Dobrucky, B., Marcokova, M., Pokorny, M. & Sul, R. (2008). Using Orthogonal and Discrete Transforms for Single-Phase PES Transients – A New Approach. *Proc. of IASTED MIC'08 Int'l Conf. on Modelling, Identification, and Control*, pp. CD-ROM, Innsbruck (AT), Feb. 2008
- Dobrucky, B., Marcokova, M., Pokorny, M. & Sul, R. (2007). Prediction of Periodical Variable Structure System Behaviour Using Minimum Data Acquisition Time. *Proc. of IASTED MIC'07 Int'l Conf. on Modelling, Identification, and Control*, pp. CD-ROM, Innsbruck (AT), Feb. 2007
- Jardan, R.K. & Dewan, B.S. (1969). General Analysis of Three-Phase Inverters, *IEEE Transactions on Industry and General Applications*, IGA-5(6), pp. 672-679.
- Mann, H. (1982). Semi-Symbolic Approach to Analysis of Linear Dynamic Systems (in Czech), *Electrical Review* 71(11), pp. 30-38
- Mayer, D., Ryjacek, Z. & Ulrych, B. (1978). Analytical Solutions of Transient Phenomena of Complex Linear Electrical Circuits (in Czech). *Horizons of Electrotechnics*, Vol. 67, No. 3, pp.137-145.
- Mohan, N., Undeland, T.M., Robbins, W.P. (2003). *Power Electronics: Converters, Applications, and Design*. John Wiley & Sons, Inc., 3. Edition, 2003, ISBN 0-471-42908-2.
- Moravcik, J. (2002). *Mathematical Analysis 3* (in Slovak), Alfa Publisher, Bratislava.
- Prikopova, A., Hargas, L., Koniar, D. (2007). Generation of the values of the polynomial function. In: *Advances in electrical and electronic engineering*, Vol. 6, ZU Zilina (SK), No. 3, pp. 117-120
- Solik, I., Vittek, J. & Dobrucky, B. (1990). Time-Optimal Analysis of Characteristic Values of Periodical Waveforms in Complex Domain, *Journal of Modelling, Simulation & Control*, AMSE Press 28(3), 1990, pp. 49-64.
- Zhujkov, V.Ja., Korotejev, I.E. & Sutchik, V.E. (1981). Algorithm for Analysis of Electrical Circuits with Variable Structure (in Russian). *Elektritchestvo*, (3), 1981, pp.35-39.



Data Acquisition

Edited by Michele Vadursi

ISBN 978-953-307-193-0

Hard cover, 344 pages

Publisher Sciyo

Published online 28, September, 2010

Published in print edition September, 2010

The book is intended to be a collection of contributions providing a bird's eye view of some relevant multidisciplinary applications of data acquisition. While assuming that the reader is familiar with the basics of sampling theory and analog-to-digital conversion, the attention is focused on applied research and industrial applications of data acquisition. Even in the few cases when theoretical issues are investigated, the goal is making the theory comprehensible to a wide, application-oriented, audience.

How to reference

In order to correctly reference this scholarly work, feel free to copy and paste the following:

Branislav Dobrucký, Mariana Marcoková and Michael Pokorný (2010). Minimum Data Acquisition Time for Prediction of Periodical Variable Structure System, *Data Acquisition*, Michele Vadursi (Ed.), ISBN: 978-953-307-193-0, InTech, Available from: <http://www.intechopen.com/books/data-acquisition/minimum-data-acquisition-time-for-prediction-of-periodical-variable-structure-system>

INTECH
open science | open minds

InTech Europe

University Campus STeP Ri
Slavka Krautzeka 83/A
51000 Rijeka, Croatia
Phone: +385 (51) 770 447
Fax: +385 (51) 686 166
www.intechopen.com

InTech China

Unit 405, Office Block, Hotel Equatorial Shanghai
No.65, Yan An Road (West), Shanghai, 200040, China
中国上海市延安西路65号上海国际贵都大饭店办公楼405单元
Phone: +86-21-62489820
Fax: +86-21-62489821

© 2010 The Author(s). Licensee IntechOpen. This chapter is distributed under the terms of the [Creative Commons Attribution-NonCommercial-ShareAlike-3.0 License](#), which permits use, distribution and reproduction for non-commercial purposes, provided the original is properly cited and derivative works building on this content are distributed under the same license.

IntechOpen

IntechOpen