

# We are IntechOpen, the world's leading publisher of Open Access books Built by scientists, for scientists

## 4,800

Open access books available

## 122,000

International authors and editors

## 135M

Downloads

Our authors are among the

## 154

Countries delivered to

## TOP 1%

most cited scientists

## 12.2%

Contributors from top 500 universities

**WEB OF SCIENCE™**Selection of our books indexed in the Book Citation Index  
in Web of Science™ Core Collection (BKCI)

Interested in publishing with us?  
Contact [book.department@intechopen.com](mailto:book.department@intechopen.com)

Numbers displayed above are based on latest data collected.  
For more information visit [www.intechopen.com](http://www.intechopen.com)



## Effect of injector nozzle holes on diesel engine performance

Semin  
*Institut Teknologi Sepuluh Nopember  
Indonesia*

Abdul Rahim Ismail  
*University Malaysia Pahang  
Malaysia*

### 1. Introduction

The four-stroke direct-injection diesel engine typical was measured and modeled by Bakar et al (2007) using GT-POWER computational model and has explored of diesel engine performance effect based on engine speeds. GT-POWER is the leading engine simulation tool used by engine and vehicle makers and suppliers and is suitable for analysis of a wide range of engine issues. The details of the diesel engine design vary significantly over the engine performance and size range. In particular, different combustion chamber geometries and fuel injection characteristics are required to deal effectively with major diesel engine design problem achieving sufficiently rapid fuel-air mixing rates to complete the fuel-burning process in the time available. According to Heywood (1988) and Ganesan (1999), a wide variety of inlet port geometries, cylinder head and piston shapes, and fuel-injection patterns are used to accomplish this over the diesel size range. The engine ratings usually indicate the highest power at which manufacturer expect their products to give satisfactory of power, economy, reliability and durability under service conditions. Maximum torque and the speed at which it is achieved, is usually given also by Heywood (1988). The importance of the diesel engine performance parameters are geometrical properties, the term of efficiency and other related engine performance parameters. The engine efficiencies are indicated thermal efficiency, brake thermal efficiency, mechanical efficiency, volumetric efficiency and relative efficiency (Ganesan, 1999). The other related engine performance parameters are mean effective pressure, mean piston speed, specific power output, specific fuel consumption, intake valve mach index, fuel-air or air-fuel ratio and calorific value of the fuel (Heywood, 1988; Ganesan, 1999; Semin et al., 2007). According to Heywood (1988) in the diesel engine geometries design written that diesel engine compression ratio is maximum cylinder volume or the displaced volume or swept and clearance volume divided by minimum cylinder volume. And the power delivered by the diesel engine and absorbed by the dynamometer is the product of torque and angular speed. The engine efficiencies, every its efficiencies defined by Ganesan (1999).

## 2. Important

In this chapter has investigated the effect of injector nozzle holes diameter geometries on the performance of diesel engine such as indicated power, indicated torque, fuel consumption and fuel in-engine cylinder. The investigation is using computational modelling based on variation engine speeds.

## 3. Engine Performance Review

In the diesel engine geometries design by Heywood (1988), the diesel engine compression ratio is maximum cylinder volume or the displaced volume or swept ( $V_d$ ) and clearance volume ( $V_c$ ) divided by minimum cylinder volume ( $V_c$ ). The diesel engine compression ratio can be calculated as below:

$$r_c = \frac{V_d + V_c}{V_c} \quad (1)$$

and the power delivered by the diesel engine and absorbed by the dynamometer is the product of torque and angular speed. Diesel engine power definition as:

$$P = 2\pi NT \quad (2)$$

In the diesel engine efficiencies, every its efficiencies defined by Ganesan (1999). Indicated thermal efficiency ( $\eta_{ith}$ ) is the ratio of energy ( $E$ ) in the indicated power ( $ip$ ) to the input fuel energy. Brake thermal efficiency ( $\eta_{bth}$ ) is the ratio of energy in the brake power ( $bp$ ), Mechanical efficiency ( $\eta_m$ ) is defined as the ratio of brake power ( $bp$ ) or delivered power to the indicated power ( $ip$ ) or power provided to the piston and it can also be defined as the ratio of the brake thermal efficiency to the indicated thermal efficiency. Relative efficiency or efficiency ratio ( $\eta_{rel}$ ) is the ratio of thermal efficiency of an actual cycle to that of the ideal cycle, the efficiency ratio is a very useful criteria which indicates the degree of development of the engine. Ganesan (1999) written that, the one of the very important parameters which decides the performance of four-stroke engines is volumetric efficiency ( $\eta_v$ ), where four-stroke engines have distinct suction stroke and therefore the volumetric efficiency indicates the breathing ability of the engine. The volumetric efficiency is defined as the volume flow rate of air into the intake system divided by the rate at which the volume is displaced by the system. The normal range of volumetric efficiency at full throttle for SI engines is 80% to 85% and for CI engines is 85% to 90%.

$$\eta_{ith} = \frac{ip}{E} \quad (3)$$

$$\eta_{bth} = \frac{bp}{E} \quad (4)$$

$$\eta_m = \frac{bp}{ip} \quad (5)$$

$$\eta_v = \frac{m_a}{\rho_a V_{disp} N / 2} \quad (6)$$

$$\eta_{rel} = \frac{\text{Actual thermal efficiency}}{\text{Air - standard efficiency}} \quad (7)$$

The other related engine performance was defined by Heywood (1988), Kowalewicz (1984), Stone (1997) and Ganesan (1999). Mean effective pressure (*mep*), where  $n_R$  is the number of crank revolutions for each power stroke per cylinder (two for four-stroke, one for two-stroke cycles) as :

$$mep = \frac{P n_R}{V_d N} \quad (8)$$

The measure of an engine's efficiency which will be called the fuel conversion efficiency is given by Heywood (1988):

$$\eta_f = \frac{W_c}{m_f Q_{HV}} = \frac{(P n_R / N)}{(m_f n_R / N) Q_{HV}} = \frac{P}{m_f Q_{HV}} \quad (9)$$

Specific fuel consumption as :

$$sfc = \frac{m_f}{P} \quad (10)$$

In the engine testing, both the air mass flow rate  $m_a$  and the fuel mass flow rate  $m_f$  are normally measured. The ratio of these flow rates is useful in defining engine operating conditions are air/fuel ratio (A/F) and fuel/air ratio (F/A).

The following relationships between diesel engine performance parameters can be developed. For power  $P$ :

$$P = \frac{\eta_f m_a N Q_{HV} (F / A)}{n_R} \quad (11)$$

$$P = \frac{\eta_f \eta_v N V_d Q_{HV} \rho_{a,i} (F / A)}{2} \quad (12)$$

For torque T :

$$T = \frac{\eta_f \eta_v V_d Q_{HV} \rho_{a,i} (F / A)}{4\pi} \quad (13)$$

For mean effective pressure :

$$mep = \eta_f \eta_v Q_{HV} \rho_{a,i} (F / A) \quad (14)$$

The specific power or the power per unit piston area is a measure of the engine designer's success in using the available piston area regardless of cylinder size. The specific power is :

$$\frac{P}{A_p} = \frac{\eta_f \eta_v N L Q_{HV} \rho_{a,i} (F / A)}{2} \quad (15)$$

Mean piston speed :

$$\frac{P}{A_p} = \frac{\eta_f \eta_v N \overline{S}_p Q_{HV} \rho_{a,i} (F / A)}{4} \quad (16)$$

Heywood (1988) written that, specific power is thus proportional to the product of mean effective pressure and mean piston speed. These relationship illustrated the direct importance to engine performance of high fuel conversion efficiency, high volumetric efficiency, increasing the output of a given displacement engine by increasing the inlet air density, maximum fuel/air ratio that can be useful burned in the engine and high mean piston speed.

#### 4. Modelling of Injector Nozzle Holes

The four-stroke direct-injection (DI) diesel engine was presented in this chapter. The specification of the selected diesel engine was presented in Table 1. To develop the four-stroke direct-injection diesel engine modeling is step by step, the first step is open all of the selected diesel engine components to measure the engine components part size. Then, the engine components size data will be input to the software library of the all engine components data. To create the model, select window and then tile with template library from the menu. This will place the template library on the left hand side of the screen. The template library contains all of the available templates that can be used in computational modeling. Some of these templates those that will be needed in the project need to be copied into the project before they can be used to create objects and parts. For the purpose of this model, click on the icons listed and drag them from the template library into the project library. Some of these are templates and some are objects that have already been defined and included in the template library (Gamma Technologies, 2004). This chapter focused on fuel nozzle hole of fuel injector. The engine modeling is according to Semin et al. (2007) as shown in Fig. 1.

All of the parameters in the model will be listed automatically in the case setup and each one must be defined for first case of the simulation. The physically of the injector fuel nozzle hole material detailed were investigated in this research is shown in Fig. 2. In this figure was showed the detail of injection hole or fuel nozzle hole. The fuel nozzle holes would be changed in wide diameter of nozzle hole and in different number of nozzle hole.

Engine Parameters	Value	Engine Parameters	Value
Model	CF186F	Intake valve close (°CA)	530
Bore (mm)	86.0	Exhaust valve open (°CA)	147
Stroke (mm)	70.0	Exhaust valve close (°CA)	282
Displacement (cc)	407.0	Max. intake valve open (mm)	7.095
Number of cylinder	1	Max. exhaust valve open (mm)	7.095
Connecting rod length (mm)	118.1	Valve lift periodicity (deg)	360
Piston pin offset (mm)	1.00	Fuel nozzle diameter (mm)	0.1
Intake valve open (°CA)	395	Fuel nozzle hole number (pc)	4

Table 1. Specification of the selected diesel engine

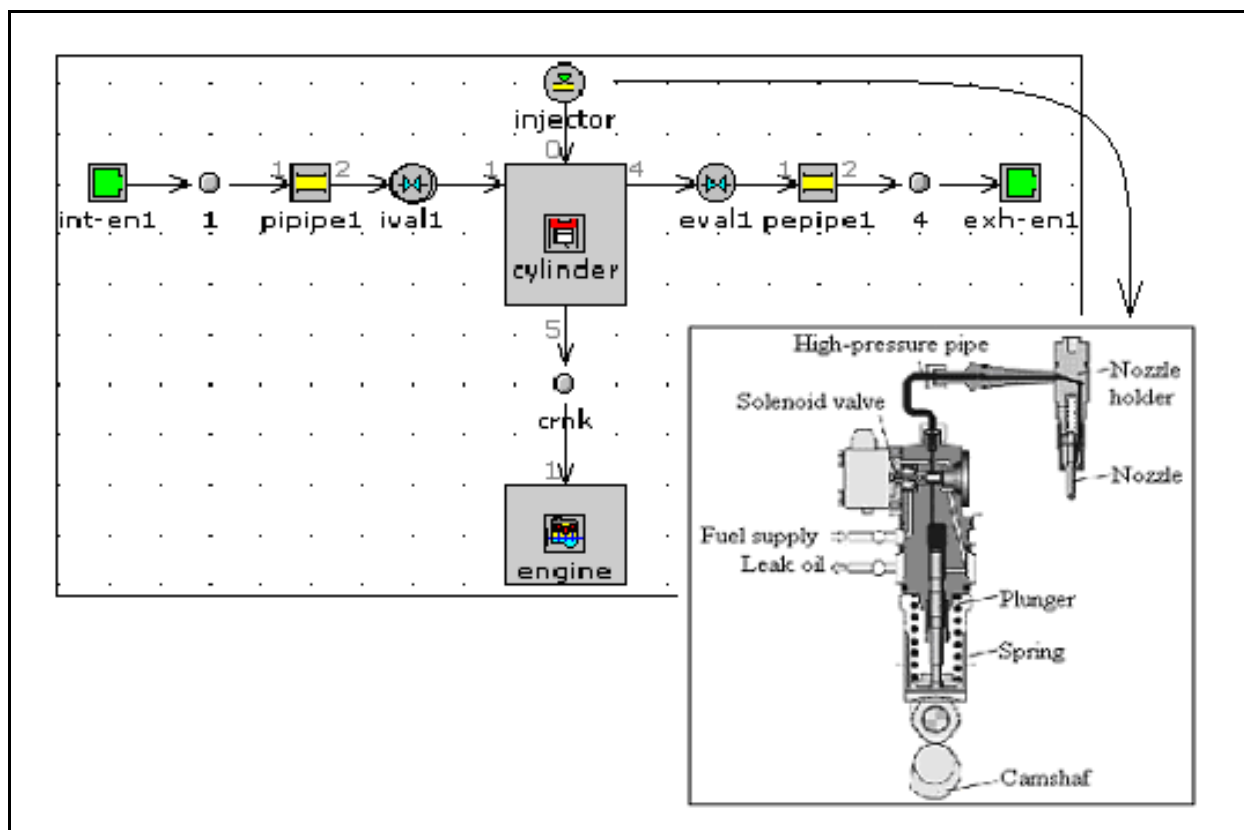

Fig. 1. Direct-injection diesel engine modeling

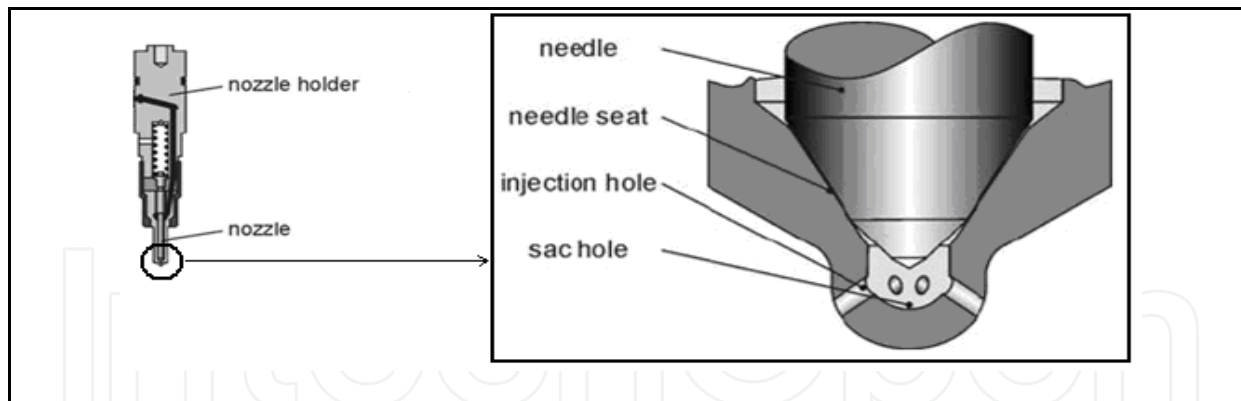

Fig. 2. Detail of injector fuel nozzle holes

Whenever the computational simulation is running, the computational model produces several output files that contain simulation results in various formats. Most of the output is available in the post-processing application. The software is powerful tool that can be used to view animation and order analysis output (Gamma Technologies, 2004). After the simulation was finished, report tables that summarize the simulations can be produced. These reports contain important information about the simulation and simulation result in a tabular form. The computational simulation of the engine model result is informed the engine performance. The running simulation result in this research is focused on the engine performance data based on variation of fuel nozzle material hole diameter size, diameter number and the different engine speed (rpm). The diesel engine model was running on any different engine speeds in rpm, there are 500, 1000, 1500, 2000, 2500, 3000 and 3500. The variations of injector fuel nozzle holes number are based on multi holes and multi diameter holes, the simulation model there are started from the injector fuel nozzle 1 hole, 2 holes, 3 holes, 4 holes, 5 holes, 6 holes, 7 holes, 8 holes, 9 holes and 10 holes.

## 5. Effect of Injector Nozzle Holes on Fuel in Engine Cylinder

The simulation results are shown in every cases, such as case 1 is on 500 rpm, case 2 is on 1000 rpm, case 3 is on 1500 rpm, case 4 is on 2000 rpm, case 5 is on 2500 rpm, case 6 is on 3000 rpm, case 7 is on 3500 rpm and case 8 on 4000 rpm. Numerous studies have suggested that decreasing the injector nozzle orifice diameter is an effective method on increasing fuel air mixing during injection (Baik, 2001). Smaller nozzle holes have found to be the most efficient at fuel/air mixing primarily because the fuel rich core of the jet is smaller. In addition, decreasing the nozzle hole orifice diameter, would reduce the length of the potential core region. Unfortunately, decreasing nozzle holes size causes a reduction in the turbulent energy generated by the jet.

Since fuel air mixing is controlled by turbulence generated at the jet boundary layer, this will offset the benefits of the reduced jet core size. Furthermore, jets emerging from smaller nozzle orifices were shown not to penetrate as far as those emerging from larger orifices. This decrease in penetration means that the fuel will not be exposed to all of the available air in the chamber. The effect of fuel nozzle holes number and geometries of in-cylinder engine liquid fuel are shown in Fig. 3 - Fig. 12,

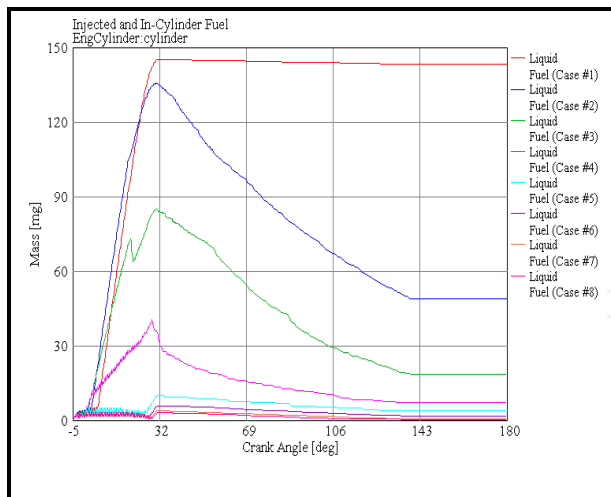

Fig. 3. Liquid fuel in cylinder of injector nozzle 1 holes

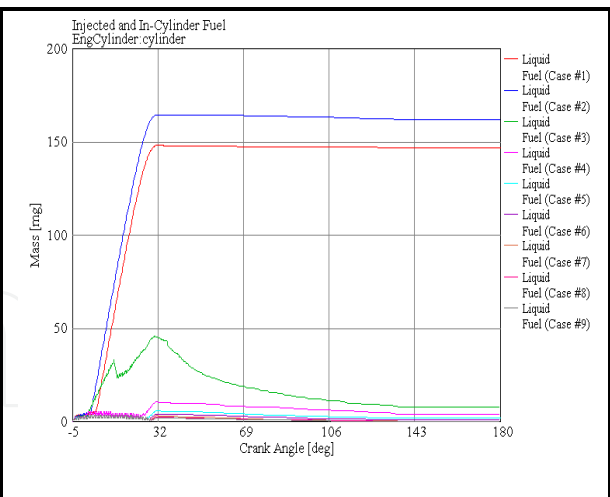

Fig. 4. Liquid fuel in cylinder of injector nozzle 2 holes

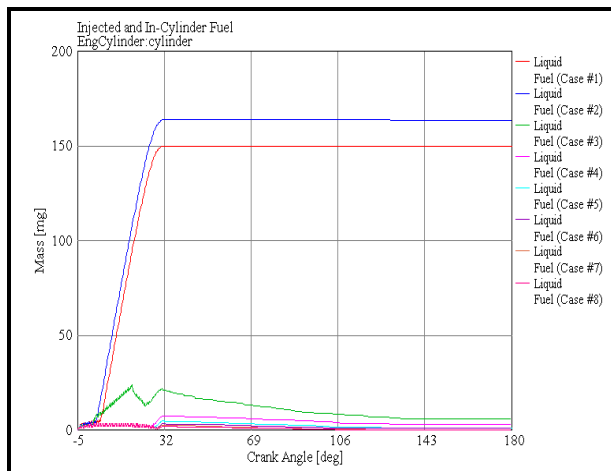

Fig. 5. Liquid fuel in cylinder of injector nozzle 3 holes

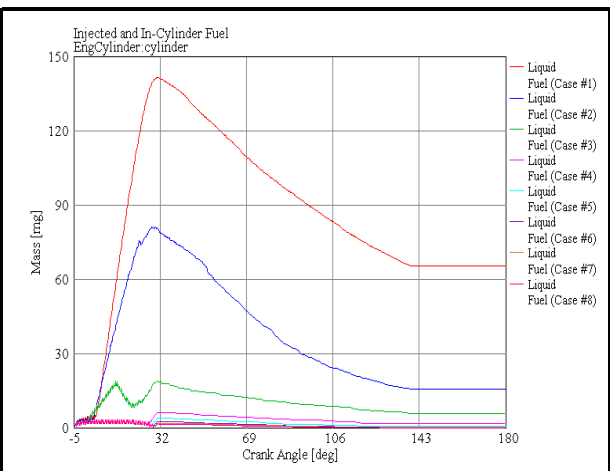

Fig. 6. Liquid fuel in cylinder of injector nozzle 4 holes

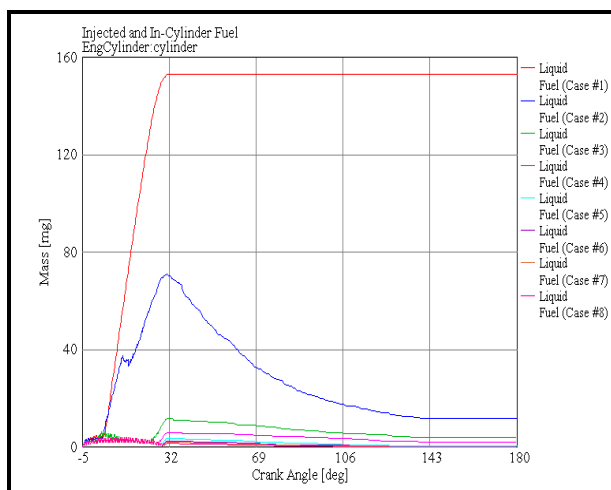

Fig. 7. Liquid fuel in cylinder of injector nozzle 5 holes

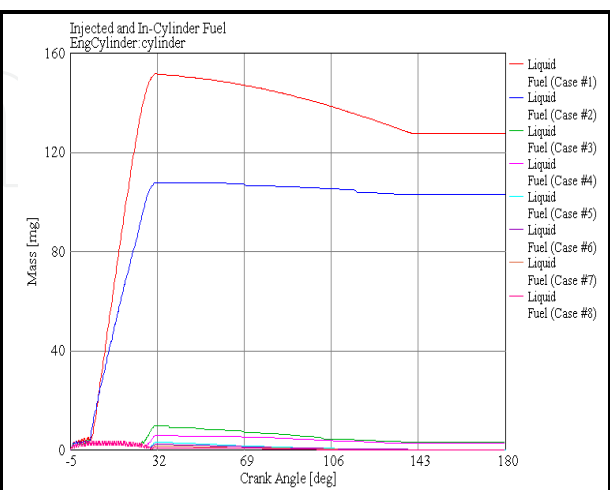

Fig. 8. Liquid fuel in cylinder of injector nozzle 6 holes



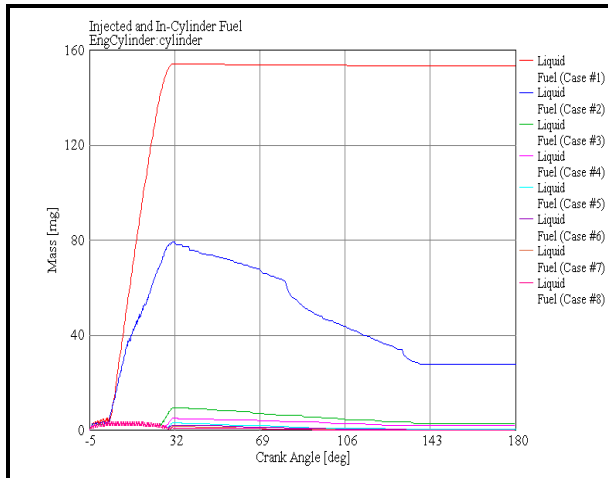

Fig. 9. Liquid fuel in cylinder of injector nozzle 7 holes

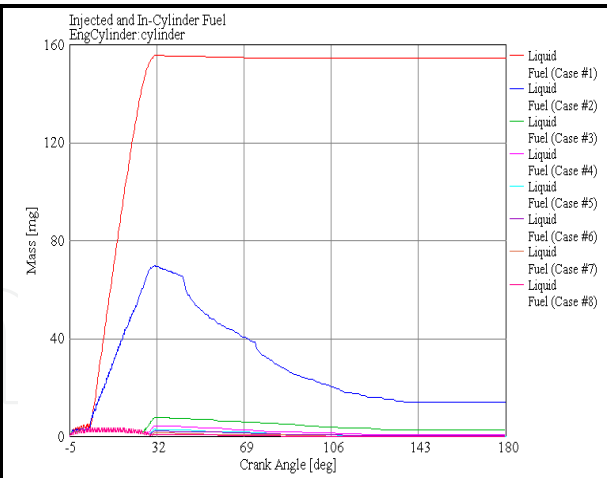

Fig. 10. Liquid fuel in cylinder of injector nozzle 8 holes

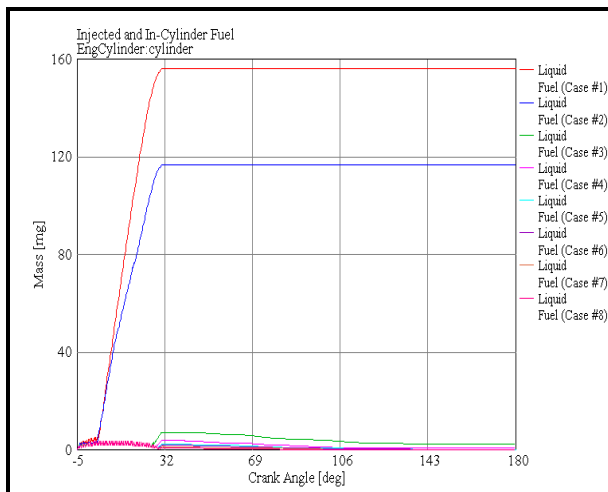

Fig. 11. Liquid fuel in cylinder of injector nozzle 9 holes

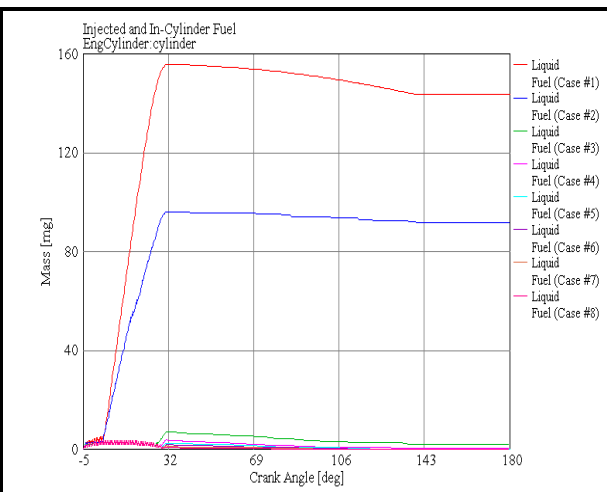

Fig. 12. Liquid fuel in cylinder of injector nozzle 10 holes

For excessively small nozzle size, the improvements in mixing related to decreased plume size may be negated by a reduction in radial penetration (Baumgarter, 2006). This behavior is undesirable because it restricts penetration to the chamber extremities where a large portion of the air mass resides. Furthermore, it hampers air entrainment from the head side of the plume because the exposed surface area of the plume is reduced. It has been suggested that a nozzle containing many small holes would provide better mixing than a nozzle consisting of a single large hole. The effect of injector nozzle multi holes in-cylinder engine unburned fuel are shown in Fig. 13 – Fig. 22.

The optimal nozzle design would be one that provided the maximum number of liquid fuel burn in combustion process and minimum number of liquid fuel unburned. Theoretically, a 10 holes nozzle satisfies this requirement. Unfortunately, jets emerging from a 10 holes nozzle tended to be very susceptible. All of the nozzles examined and the result shown that the seven holes nozzle provided the best results for any different engine speeds in simulation and the best performance shown on low speed engine.

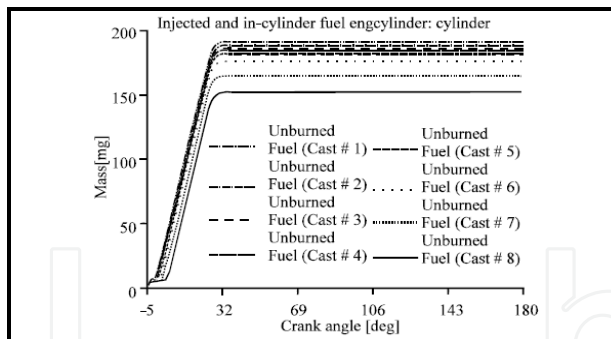

Fig. 13. Unburned fuel in cylinder of injector nozzle 1 holes

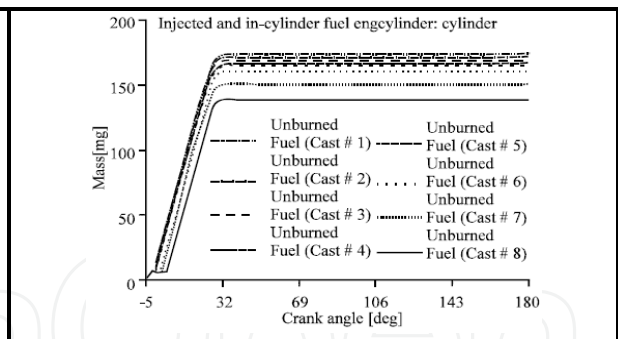

Fig. 14. Unburned fuel in cylinder of injector nozzle 2 holes

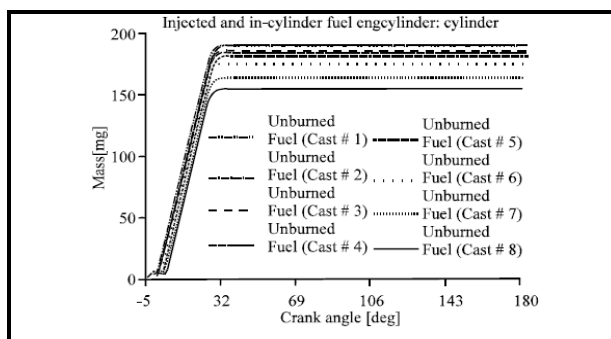

Fig. 15. Unburned fuel in cylinder of injector nozzle 3 holes

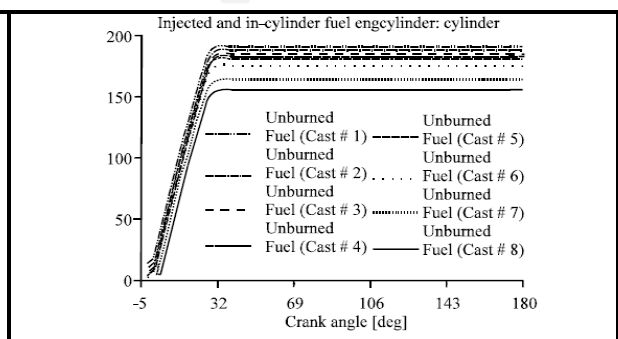

Fig. 16. Unburned fuel in cylinder of injector nozzle 4 holes

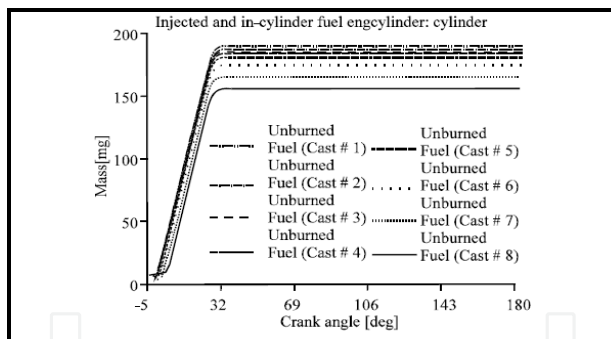

Fig. 17. Unburned fuel in cylinder of injector nozzle 5 holes

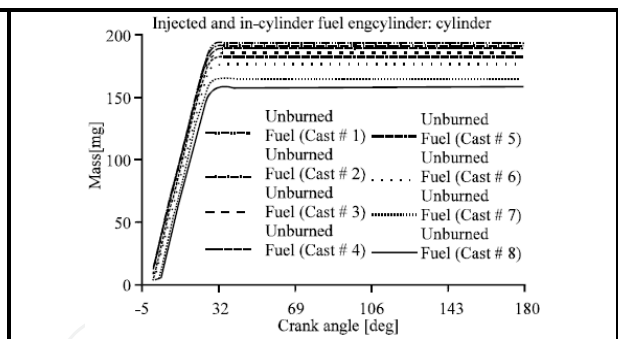

Fig. 18. Unburned fuel in cylinder of injector nozzle 6 holes

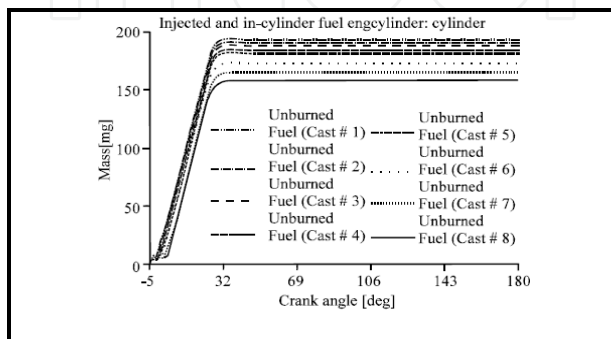

Fig. 19. Unburned fuel in cylinder of injector nozzle 7 holes

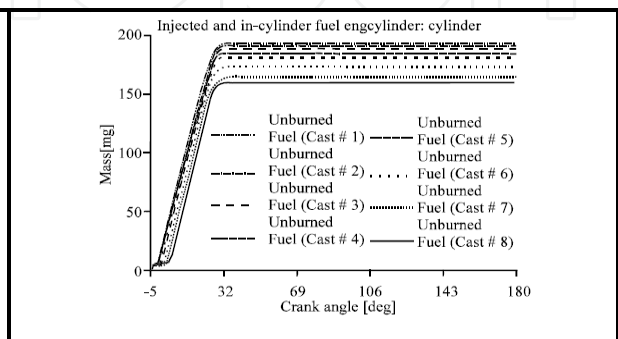

Fig. 20. Unburned fuel in cylinder of injector nozzle 8 holes

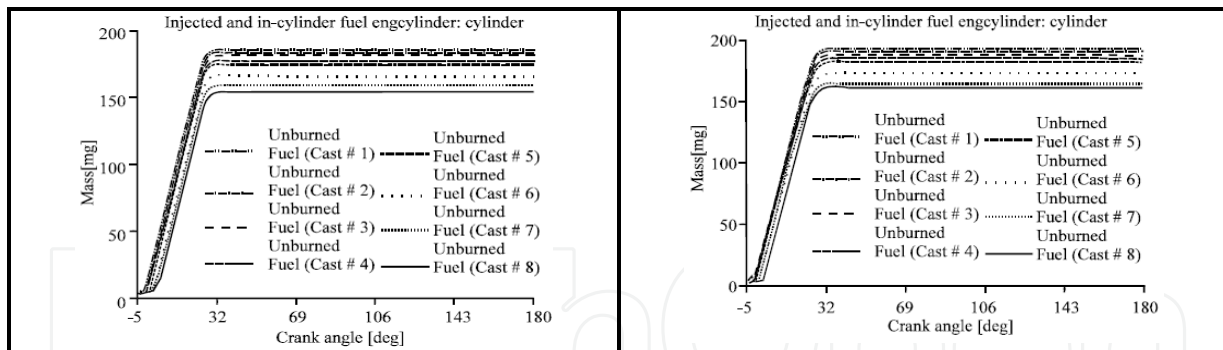

Fig. 21. Unburned fuel in cylinder of injector nozzle 9 holes

Fig. 22. Unburned fuel in cylinder of injector nozzle 10 holes

### 6. Effect of Injector Nozzle Holes on Engine Performance

The simulation result on engine performance effect of injector fuel nozzle holes number and geometries in indicated power, indicated torque and indicated specific fuel consumption (ISFC) of engine are shown in Figure 23 – 25. The injector fuel nozzle holes orifice diameter and injector nozzle holes numbers effect on indicated power, indicated torque and ISFC performance of direct-injection diesel engine was shown from the simulation model running output. An aerodynamic interaction and turbulence seem to have competing effects on spray breakup as the fuel nozzle holes orifice diameter decreases. The fuel drop size decreases if the fuel nozzle holes orifice diameter is decreases with a decreasing quantitative effect for a given set of jet conditions.

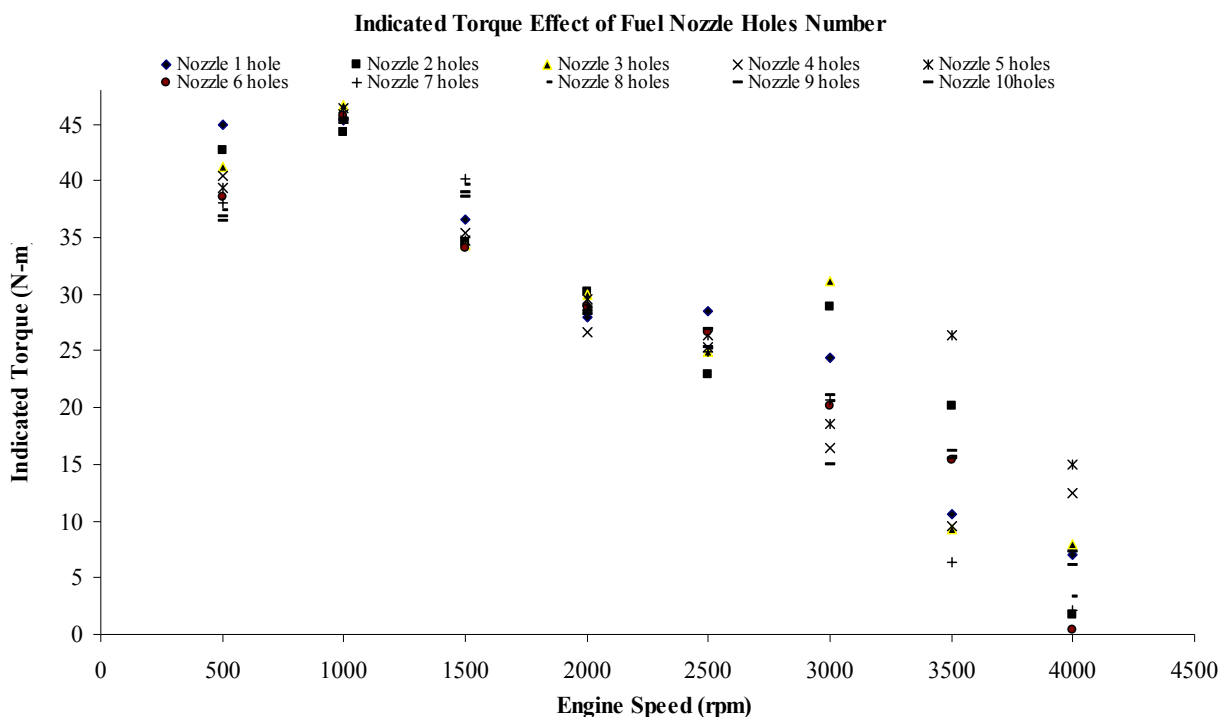

Fig. 23. Effect of fuel nozzle holes on indicated torque of diesel engine

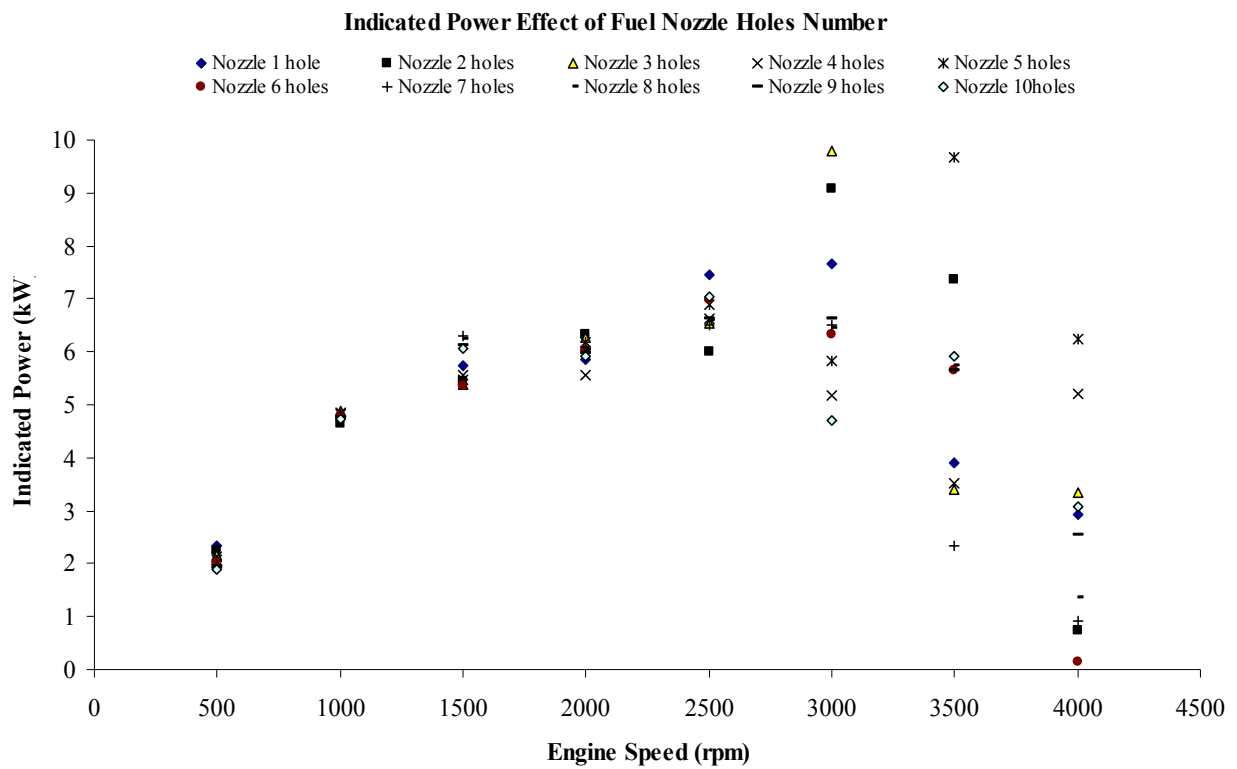

Fig. 24. Effect of fuel nozzle holes on indicated power of diesel engine

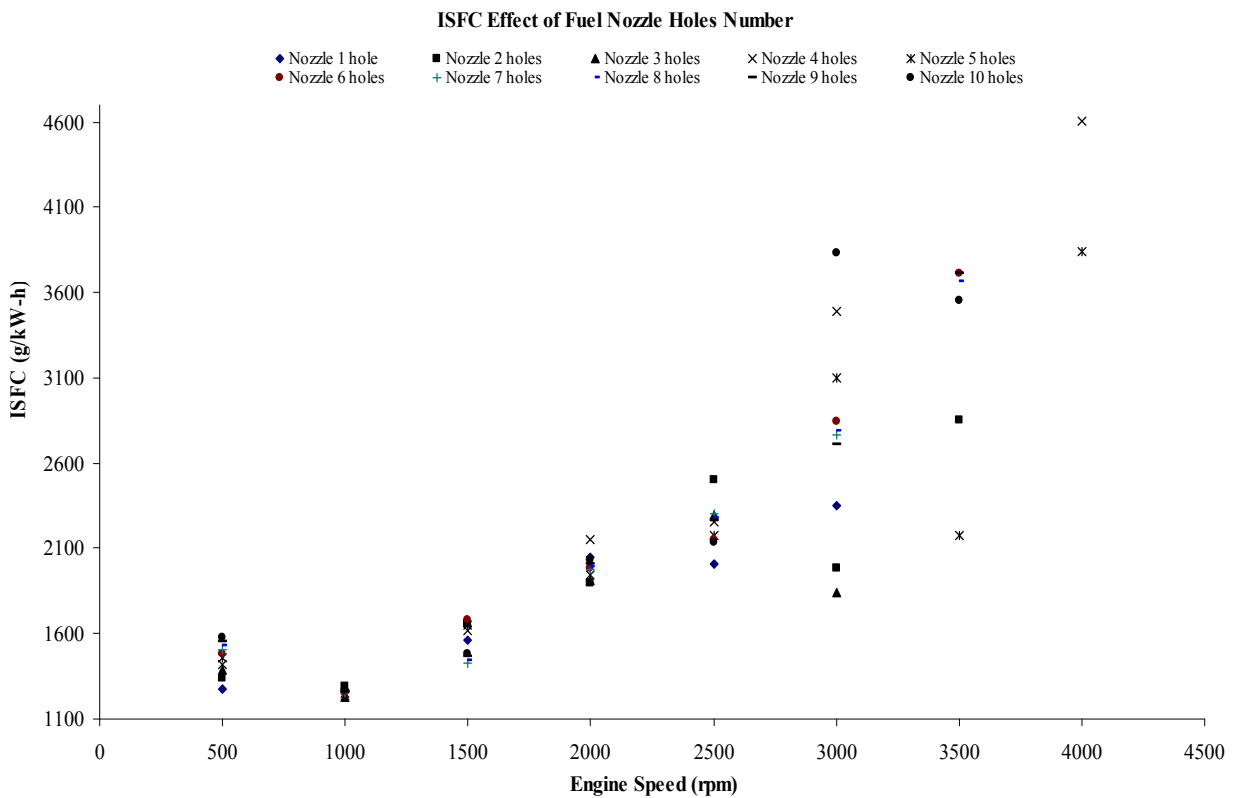

Fig. 25. Effect of fuel nozzle holes on ISFC of diesel engine

Fuel-air mixing increases as the fuel nozzle holes orifice diameter fuel nozzle holes decreases. Also soot incandescence is observed to decrease as the amount of fuel-air premixing upstream of the lift-off length increases. This can be a significant advantage for small orifice nozzles hole. However, multiple holes orifices diameter required to meet the desired mass flow rate as orifice diameter decreases. In this case, the orifices diameter need to placed with appropriate spacing and directions in order to avoid interference among adjacent sprays. The empirical correlations generally predict smaller drop size, slower penetrating speed and smaller spray cone angles as the orifice diameter decreases, however the predicted values were different for different relation. All of the nozzles have examined and the results are shown that the five holes nozzle provided the best results for indicated torque, indicated power and ISFC in any different engine speed in simulation.

## 7. Conclusion

All of the injector nozzle holes have examined and the results are shown that the seven holes nozzle have provided the best burning result for the fuel in-cylinder burned in any different engine speeds and the best burning is in low speed engine. In engine performance effect, all of the nozzles have examined and the five holes nozzle provided the best result in indicated power, indicated torque and ISFC in any different engine speeds.

## 8. References

- Baik, Seunghyun. (2001). Development of Micro-Diesel Injector Nozzles Via MEMS Technology and Effects on Spray Characteristics, *PhD Dissertation*, University of Wisconsin-Madison, USA.
- Bakar, R.A., Semin., Ismail, A.R. and Ali, Ismail., 2008. Computational Simulation of Fuel Nozzle Multi Holes Geometries Effect on Direct Injection Diesel Engine Performance Using GT-POWER. *American Journal of Applied Sciences* 5 (2): 110-116.
- Baumgarter, Carsten. (2006). *Mixture Formation in Internal Combustion Engines*, Springer Berlin.
- Gamma Technologies, (2004). *GT-POWER User's Manual 6.1*, Gamma Technologies Inc.
- Ganesan, V. (1999). *Internal Combustion Engines 2<sup>nd</sup> Edition*, Tata McGraw-Hill, New Delhi, India.
- Heywood, J.B. (1988). *Internal Combustion Engine Fundamentals - Second Edition*, McGraw-Hill, Singapore.
- Kowalewicz, Andrzej., 1984. *Combustion System of High-Speed Piston I.C. Engines*, Wydawnictwa Komunikacji i Łączności, Warszawa.
- Semin and Bakar, R.A. (2007). Nozzle Holes Effect on Unburned Fuel in Injected and In-Cylinder Fuel of Four Stroke Direct Injection Diesel Engine. *Presearch Journal of Applied Sciences* 2 (11): 1165-1169.
- Semin., Bakar, R.A. and Ismail, A.R. (2007). Effect Of Engine Performance For Four-Stroke Diesel Engine Using Simulation, *Proceeding The 5<sup>th</sup> International Conference On Numerical Analysis in Engineering*, Padang-West Sumatera, Indonesia.
- Stone, Richard. (1997). *Introduction to Internal Combustion Engines-Second Edition*, SAE Inc, USA.



## **Fuel Injection**

Edited by Daniela Siano

ISBN 978-953-307-116-9

Hard cover, 254 pages

**Publisher** Sciyo

**Published online** 17, August, 2010

**Published in print edition** August, 2010

Fuel Injection is a key process characterizing the combustion development within Internal Combustion Engines (ICEs) and in many other industrial applications. State of the art in the research and development of modern fuel injection systems are presented in this book. It consists of 12 chapters focused on both numerical and experimental techniques, allowing its proper design and optimization.

### **How to reference**

In order to correctly reference this scholarly work, feel free to copy and paste the following:

Semin Semin, Mohd Yuzri Mohd Yusof, Aminuddin Md Arof, Daneil Tomo Shaharudin and Abdul Rahim Ismail (2010). Effect of Injector Nozzle Holes on Diesel Engine Performance, Fuel Injection, Daniela Siano (Ed.), ISBN: 978-953-307-116-9, InTech, Available from: <http://www.intechopen.com/books/fuel-injection/effect-of-injector-nozzle-holes-on-diesel-engine-performance>

**INTECH**  
open science | open minds

### **InTech Europe**

University Campus STeP Ri  
Slavka Krautzeka 83/A  
51000 Rijeka, Croatia  
Phone: +385 (51) 770 447  
Fax: +385 (51) 686 166  
[www.intechopen.com](http://www.intechopen.com)

### **InTech China**

Unit 405, Office Block, Hotel Equatorial Shanghai  
No.65, Yan An Road (West), Shanghai, 200040, China  
中国上海市延安西路65号上海国际贵都大饭店办公楼405单元  
Phone: +86-21-62489820  
Fax: +86-21-62489821

© 2010 The Author(s). Licensee IntechOpen. This chapter is distributed under the terms of the [Creative Commons Attribution-NonCommercial-ShareAlike-3.0 License](#), which permits use, distribution and reproduction for non-commercial purposes, provided the original is properly cited and derivative works building on this content are distributed under the same license.

IntechOpen

IntechOpen