

# We are IntechOpen, the world's leading publisher of Open Access books Built by scientists, for scientists

**4,800**

Open access books available

**122,000**

International authors and editors

**135M**

Downloads

Our authors are among the

**154**

Countries delivered to

**TOP 1%**

most cited scientists

**12.2%**

Contributors from top 500 universities



**WEB OF SCIENCE™**

Selection of our books indexed in the Book Citation Index  
in Web of Science™ Core Collection (BKCI)

Interested in publishing with us?  
Contact [book.department@intechopen.com](mailto:book.department@intechopen.com)

Numbers displayed above are based on latest data collected.

For more information visit [www.intechopen.com](http://www.intechopen.com)



# Rule-Based System for Morphological and Ecohydrological Decision Making

Hani Sewilam and Heribert Nacken  
*RWTH Aachen University  
Germany*

## 1. Introduction

“Fish habitat is defined as those parts of the environment that fish depend on, directly or indirectly, in order to carry out their life processes” (Alberta 2003). There are basic requirements that should be available so that fish can successfully carry out their life processes; fish must have food to be able to reproduce and need cover to protect themselves from predators. The biological, chemical and physical features of water streams must be suitable for the reproduction process. Changes in the morphology of water streams are significant factors that influence the habitat quality (Hauer et al. 2006). Geomorphic characteristics, such as channel size, slope, grain size distribution, the spatial configuration of bars and riparian vegetation, strongly influence the structure of fluvial habitats and, as a consequence, the biodiversity and ecosystem function (Zah et al. 2000). Scherer et al. (2006) analyse the correlation between the structural river quality and the existing fish fauna. The study points out that there is a significant correlation between the species composition and the aggregated hydromorphological indicators for the trout and grayling regions. Montgomery (2006) indicates that the historical effects of changes in river geomorphologic processes in the US led to disturbance regimes on salmon populations. This shows the significance of the morphological structure for the ecosystem of watercourses.

Over the past centuries, the ecological quality of watercourses in Europe and worldwide has been affected by human actions. Many physical alterations such as flood control measures, barrages, sluices as well as canalization and lining have significantly affected the Ecosystem mainly fish habitat. Improving the status of surface and ground water is a clear objective of the EU Water Framework Directive (EU WFD) to be achieved by 2015 (European Parliament 2000). The EU WFD committed the EU nations to carry out a characterisation of their water bodies by the end of 2004. This entailed a complete analysis of the characteristics of the surface and ground waters in each district, the review of the environmental impact of human activity (industry, farming, etc.) and an economic analysis of water use. The EU WFD also emphasizes the importance of preparing programmes of measures to achieve and maintain the good ecological status of watercourses.

The German Ministry of Environment and Conservation, Agriculture and Consumer Protection of the state of North Rhine-Westphalia (MUNLV) has achieved, over the past years, a significant improvement of the chemical status of the watercourses in North Rhine-Westphalia (NRW). The improvement of wastewater treatment and the decrease of industrial pollutants had a positive effect on the chemical quality already in 2001. Sixty

Source: Decision Support Systems, Advances in, Book edited by: Ger Devlin,  
ISBN 978-953-307-069-8, pp. 342, March 2010, INTECH, Croatia, downloaded from SCIYO.COM

percent of the examined water courses reached a “good” or “very good” status. Thirty percent were rated as “moderate”. The concentrations of nutrients and pollutants have notably decreased (North Rhine-Westphalia State Environment Agency (LUA NRW) 2002). On the other hand, the morphological structure of these watercourses has considerable deficits, particularly in urban areas. The results of a morphological quality assessment study indicate that 48.6% of the small and medium-sized watercourses in NRW are strongly affected by human activities. In urban areas this percentage increases to 73.6% (North Rhine-Westphalia State Environment Agency (LUA NRW) 2003).

To achieve the environmental objectives of the EU WFD, the MUNLV is in the course of preparing programmes of measures to improve the ecological status of the watercourses.

The programmes of measures have to be elaborated for each watercourse. The decision makers at ministerial and regional levels need supporting tools that enable them to plan the programmes of measures in NRW as well as identifying the suitability of water courses for fishes.

This chapter introduces a Decision Support System that partially contributes to the development of the programmes of measures. The tool considers only the morphological structure, since the improvement of morphological quality is the basis for a good ecological status. The developed system generates different scenarios for a morphological restoration measure, assesses their impacts and proposes a programme of morphological measures and preliminary cost estimation for all WFD-relevant watercourses in NRW. The DSS has been developed for use at both ministerial and regional levels. Decision makers at ministerial level need the tool for more strategic and resources allocation reasons. However, local or regional authorities need the tool to support the development of the morphological improvement programme of measures for their watercourses. In addition, this chapter introduces also the first results of further development of the DSS aiming to support the decision makers in identifying the impact of river restoration on the suitability of water streams for Salmon fish.

## 2. Characterization of watercourses

The characterization process is considered the first step toward implementation of the EU WFD. Characterization process is meant to assess environmental pressures on water bodies and the impact of human activity on watercourse status (Umwelt Bundes Amt 2005).

German Working Group of the Federal States (LAWA) (1998) has elaborated a characterization system that allows the assessment of the hydromorphological quality of water bodies. As listed in Table 1, the quality classification system considers 14 hydromorphological indicators which cover different morphological structure areas (longitudinal variation, bed configuration, bank structure, etc.). The classification system breaks down a water body into segments (100 m long). The segments should be assessed by allocating a value between 1 and 7 to each of its hydromorphological indicators, whereby class 1 stands for the natural state and class 7 for a completely changed state.

## 3. Rule-based modelling

Hydromorphologically related processes can be characterized as the most complex natural processes to be mathematically modelled. Normally, experts in the field of watercourse restoration do not communicate in the form of systems of differential equations or analytical

	Hydromorphological Indicators	Investigated Area
1	Curvature	Longitudinal Variation
2	Mobility	
3	Natural elements	Longitudinal Profile
4	Anthropogenic migration barrier	
5	Type and spreading of substrates	Bed Configuration
6	Bed fixation	
7	Cross-section form	Cross Section
8	Cross-section depth	
9	Width variation	
10	Vegetation	Bank Structure
11	Bank characteristics	
12	Natural Characteristics	
13	Foreland	Stream Surroundings
14	Bank Width	

Table 1. Hydromorphological Indicators and Related Investigated Areas

models, but they use natural languages and qualitative reasoning for the description of morphological relationships. Realistic and successful decisions to improve the morphological structure of watercourses are often based on expert knowledge. The main problems of the expert-based decision-making process are the scarcity of such experts and the enormous amount of data to be handled.

Artificial Intelligence (AI) techniques were meant to solve similar modelling problems.

The appearance of AI in environmental sciences publications began in the middle of the 1980s. In the 1990s there was a significant increase in the number of published papers in this field (Cortés et al. 2000). Knowledge-based modelling is among the AI techniques that are intensively used in modelling ecological processes. Knowledge can be represented in several ways, such as rules, frames and logical predicates. In most knowledge-based systems, knowledge is expressed in rules (Domanski 1989). The most powerful characteristic of rule-based modelling, making them different from traditional computer applications, is their capability to deal with qualitatively described situations. Different examples for rule-based ecological modelling can be found in literature (e.g. Bender et al. 1992, Vicente et al. 2004 and Schülter et al. 2006).

To deal with the enormous amount of data and to develop the targeted DSS, the rulebased modelling technique is used in this study. In NRW, there are about 120,000 watercourse segments (100 m) that should be investigated to answer questions such as: which segments should be rehabilitated and which combination of measures should be implemented? During an early stage of this research, the knowledge of experts was obtained through interviews and questionnaires. Based on the acquired knowledge, different 'if-then' rules have been formulated. Experts were asked again to interact together during workshops to assess the identified rules. In addition to the technical discussion, a classical voting procedure was followed in case of diverging opinions. The rules are devoted to solving two main modelling problems.

### 3.1 Identifying decision space

The first decision making step is to identify the decision space which is formulated through different restrictions. In this specific decision problem, the restrictions of implementing a morphological improvement measure are technical restrictions. The restoration measure which satisfies the predefined restrictions is considered a feasible decision scenario. The main idea is to identify the decision space using qualitative 'if-then' rules. The rules are included in Rule-Block 1. An example for considering technical restrictions using 'if-then' rules can be formulated as follows:

IF	Cross-Section Form	IS	Class 5, 6 or 7
AND	Cross-Section Depth	IS	Class 5, 6, or 7
AND	Width Variation	IS	Class 4, 5, 6, or 7
AND	Bank Characteristics	IS	Class 1, 2 or 3
THEN	Widening Cross Section	IS	Feasible Measure

It can be realized from this rule that widening the cross section is suitable for improving its form, depth and variation. On the other hand, enough bank width should be available to widen the cross section. The DSS offers 25 different measures to improve the morphological status of watercourses. For instance, removing the bed-fixing materials is a measure to rehabilitate the bed characteristics and placement of woody debris is proposed to improve the cross section. There is at least one rule for each measure to identify its feasibility.

### 3.2 Qualitative simulation

The second decision making step is to qualitatively predict the impact of implementing a feasible measure on the morphological structure of a watercourse segment over a predefined time duration. For this purpose, different restoration functions have been developed to describe the impact of each measure on one hydromorphological indicator. As a matter of fact, a measure could have impacts on more than one hydromorphological indicator. Therefore, the 25 measures included in the DSS have 95 restoration functions.

Figure 1 provides an example for a restoration function describing the impact of removing the bed-fixing materials on the type and spreading of substrates. To handle the different ecological effects due to diverse conditions and constraints in nature, the DSS offers three restoration scenarios for each measure (optimistic, medium and pessimistic).

Considering the optimistic scenario, the morphological status will improve tremendously after removing the bed-fixing materials (from class 7 to class 4). Assuming a time duration of 5 years, the morphological status will be improved from class 4 to class 3. Two other restoration functions are constructed for this measure because this measure also has a positive impact on the two indicators "bed fixation" and "anthropogenic migration barrier." To summarize the impact of each measure on the investigated segment, another rule block which contains 'if-then' rules has been constructed. The rules capture the impact of the measures from the related restoration functions. This example illustrates the impact of removing bed fixation on different hydromorphological indicators after 5 years of implementation.

IF	Stream Bed Fixation	IS	Class 7
AND	Type and Spreading of Substrates	IS	Class 7
AND	Anthropogenic Migration Barrier	IS	Class 7
AND	Removing the Bed Fixation	IS	Implemented



AND	Development Time	IS	5 Years
THEN	Stream Bed Fixation	IS	Class 1
AND	Type and Spreading of Substrates	IS	Class 3
AND	Anthropogenic Migration Barrier	IS	Class 5

The 14 morphological indicators are used to assess the efficiency of the investigated scenario. After implementing the second rule base, each of the 14 indicators of the investigated segment gets a new morphological status. The new values of the morphological indicators are used to rank the scenarios. The DSS includes an algorithm that allows the user to select only low-cost measures. In this case, the number of investigated measures is reduced to include only low-cost ones. This means that the expensive measures will be excluded. At this stage, the DSS does not consider the connection between the segments. For example, the impact of implementing a certain measure in an upper reach on segments in lower reaches is not considered. However, this issue is considered for further development of the DSS by using data mining techniques.

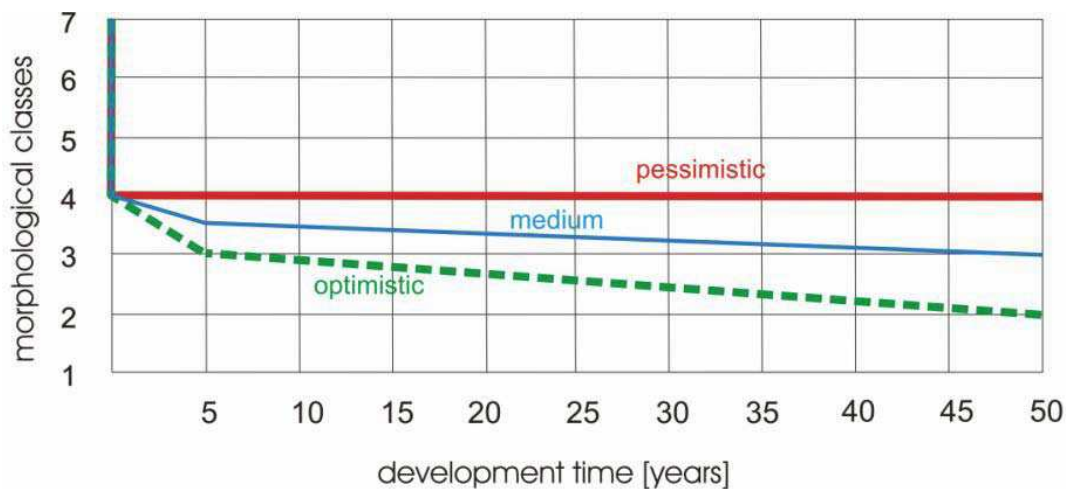

Fig. 1. Example of a restoration function for the measure “Removing the Bed Fixation” and its impact on the hydromorphological indicator “type and spreading of substrates”

#### 4. Structure of the DSS

The overall structure of the DSS is shown in Fig. 2. It contains four major subsystems, namely, the graphical user interface (GUI) subsystem, the data management subsystem, the rule-inference subsystem and the assessment subsystem.

- The GUI subsystem serves to integrate the other three subsystems and to allow the decision maker or the user to interact with the DSS. The GUI coordinates all functions selected by the decision maker. It allows the user to have access to all data. The user can select the water body to be improved, identify the targeted morphological status (restoration objective) and time duration to reach this target. The user can also control the available restoration measures, add or remove rules in the database as well as the cost of the different scenarios. The proposed programme of measures for the selected water body is also delivered through the GUI.
- The data-management subsystem stores and organizes all data and rules necessary for the other subsystems to solve the decision problem. This subsystem contains all the

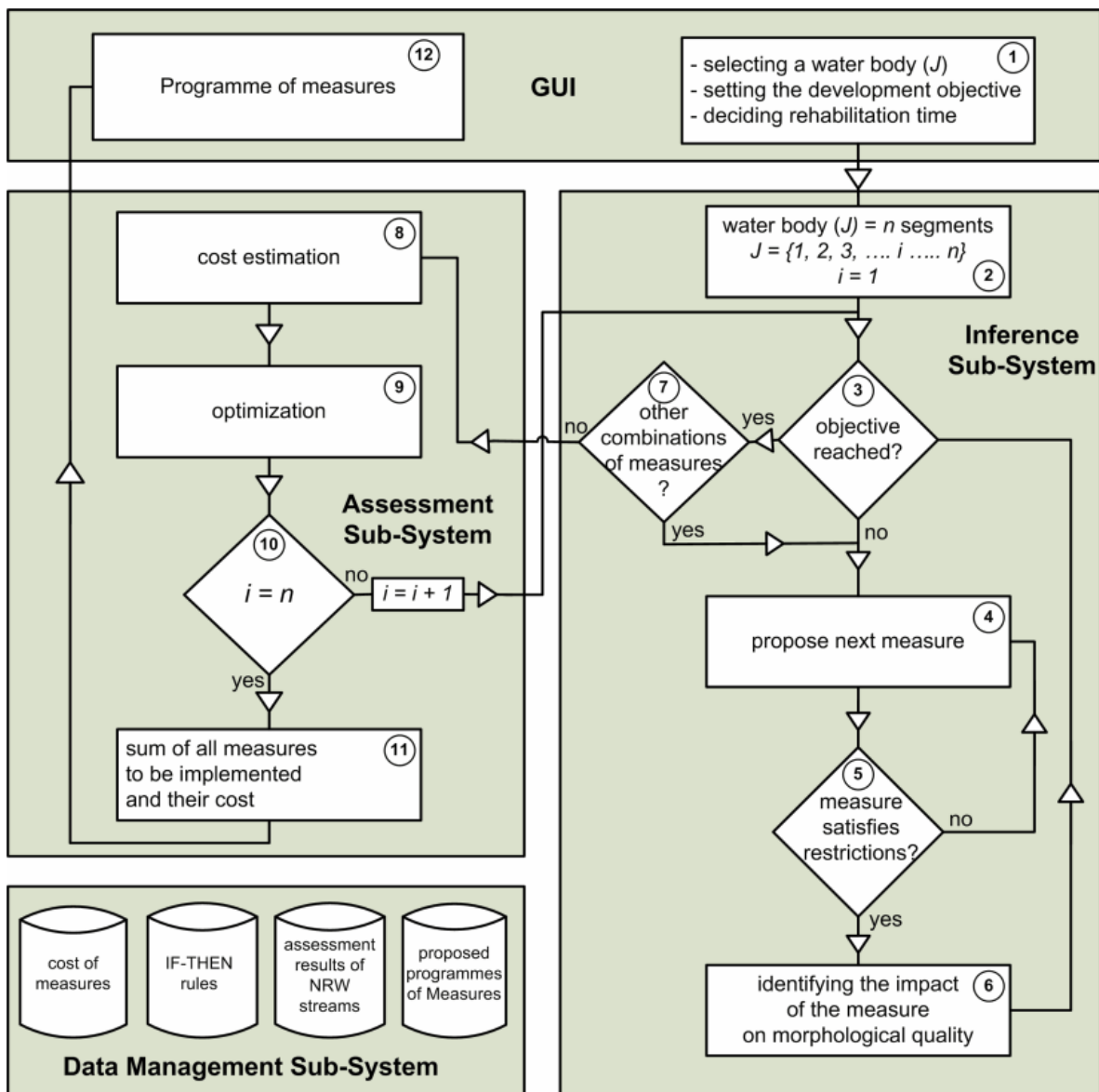

Fig. 2. The Architecture of the DSS and Decision Making Procedure

results of the morphological characterization in NRW (current status), rules for selecting the decision scenarios, rules for predicting the impact of implemented measures and cost of the measures.

- The rule-inference subsystem is the core component of the DSS which contains the two rule blocks. This subsystem is responsible for generating different restoration scenarios, checking their feasibility, implementing them and assessing their impact on the morphological structure of the investigated water body.
- The assessment subsystem is devoted to estimating the cost of the proposed measures. The DSS offers functions that estimate the cost of the measures. This subsystem contains also an optimization module that selects the best combination of measures for a certain water body based on the cost of the measures and their performance toward reaching the best possible morphological status. This subsystem also summarizes the measures selected for a certain water body as well as their cost to produce the expected programme of measures.

## 5. Development of morphological restoration measures

To improve the ecological status of watercourses, programmes of measures should be developed and implemented. Since this work targets only the morphological structure, the DSS has been developed to propose only morphological restoration measures as important components of the programmes of measures. Figure 2 illustrates the decision-making procedure toward developing an optimal combination of measures to improve the morphological status for a selected water body. The procedure can be summarized as follows:

1. The user selects a water body (J) and identifies the morphological development objectives that should be achieved by the DSS. For instance, the current status of the selected water body is class 6 and the restoration objective is to improve the structure to reach class 2. The user is also asked to identify the maximum duration to achieve the restoration objective (e.g. 4 years).
2. The system breaks down the selected water body to (n) number of segments (100 meters long).
3. If the current status of the investigated segment (i) is equal to or better than the targeted class, the system jumps to step 7. If not,
4. The system proposes a restoration measure.
5. The system implements the first rule block to check whether the selected measure satisfies the restrictions or not. If not, the system proposes another measure (back to step 3). If yes,
6. The system implements the second rule block to identify the impact of the selected measure on the morphological status of the investigated segment. Then the system moves again to step 3 to check whether the targeted objective has been achieved or not. If not, the same procedure will be followed to suggest additional measures to be implemented for the same segment (combination of several measures). If yes,
7. The system asks again whether there is any other combination of measures that can lead to the targeted morphological status. If the answer is yes, the system jumps to step 4. If not,
8. All the combinations of measures resulting from the previous steps that lead to the targeted status are sent to the cost estimation module. This module breaks down the measures into smaller sub-measures (site preparatory costs, planning costs, etc.) and picks up the cost of each sub-measure from the data-base subsystem. The costs depend on the size and the type of the river segment. The prices represent an average value of similar projects that have already been implemented and are the same for all rivers in NRW. The cost estimation aims mainly at comparing of different combinations of measures for one river. Since the costs are based on the same database, a comparison is possible.
9. Then, an optimization algorithm is started which aims to select the best “combination of measures” according to two selection criteria, (a) the combination of measures that leads to the best morphological quality, and (b) the cheapest combination of measures.
10. Then, the system asks whether all the segments of the selected water body have been investigated. If not, the system jumps to step 2. If yes,
11. The best combination of measures for each segment is aggregated to formulate a morphology-improving programme of measures for the selected water body. Then,
12. The GUI delivers the best three morphology-improving programmes of measures for the selected water body.



For any selected water body in NRW, the developed DSS produces a detailed report for the restoration programme of measures. The report includes the best three combinations of measures to be implemented and the estimated cost. The predicted results can be visualised using GIS.

## 6. Validation of the DSS

To demonstrate the applicability of the developed DSS, the data of the NRW restoration surveillance project "Erfolgskontrolle" have been used for comparison with the DSS results. This project aims to compare the status of watercourses before and after implementing morphological restoration measures (German Ministry of Environment and Conservation 2005). The majority of experts who participated in this project were not involved in formulating the rule base of the DSS. This is important for the reliability of the validation process. Data limitation was a problem that faced validating most of the river segments of the "Erfolgskontrolle" project. Therefore, validation tests were undertaken only for the segments with enough data to run the DSS.

To validate Rule Block 1, the DSS was run for the river segments of the "Erfolgskontrolle," which are spread all over NRW, with the same developing time and goal to be achieved. The proposed combinations of measures were compared with the ones implemented in the projects of the "Erfolgskontrolle." The results showed that the combinations of measures which were implemented in reality are included in the list of suggested combinations by the DSS. To validate the restoration functions, the data of 16 different river segments analyzed in the "Erfolgskontrolle" project were used. With a special tool of the DSS ("Interaktive Prognose") the user can select specific measures proposed by Rule Block 1. This tool was used with the data of the "before" status and the developing time of the given data of the "Erfolgskontrolle." For each project an optimistic, a pessimistic and a normal scenario were run. The results of the "Interaktive Prognose" were compared with the real data of the "after" status. The results showed a good agreement between the predicted morphological status and the real world ones. In 14 projects the maximum recorded difference in the aggregated indicator using the medium restoration function is one morphology class.

## 7. Implementing the DSS in NRW

In order to allocate resources and develop general morphological programmes of measures in NRW, the MUNLV started implementing the DSS in different schemes. The MUNLV implemented the DSS for seven rivers in NRW: Stever, Berkel, Sieg, Niers, Issel, Wienbach and Ottersgraben. The experts involved described the DSS results as "reasonable" measures. For the Berkel, a lowland river with mainly agricultural landuse, the results are given here in more detail. The aggregated total morphological quality of the Berkel (mean quality of all segments) is currently class 6. The specified target for the morphological quality is class 3. The developing time is set at 18 years with minimal costs. The optimistic restoration scenario recommended mainly developing measures such as 'support for riverine vegetation', deadwood measures or 'broaden the bank width'. The DSS suggests that all anthropogenic migration barriers be removed to restore a continuous river. For some segments, no suitable measure is found or required for the overall goal of class 3. The suggested combinations of measures will improve the morphology to class 3 in 75% of the river segments as shown in Table 2. In total an aggregated morphological quality of class 3.47 is reached.

morphological quality class	1	2	3	4	5	6	7
distribution before the implementation [%]	0,0	0,0	0,6	9,0	18,5	61,7	10,1
proposed distribution after the implementation and the developing time [%]	0,0	3,6	75,8	0,8	2,7	11,6	5,6

Table 2. Distribution of the morphological quality classes before and after the measures of the Berkel

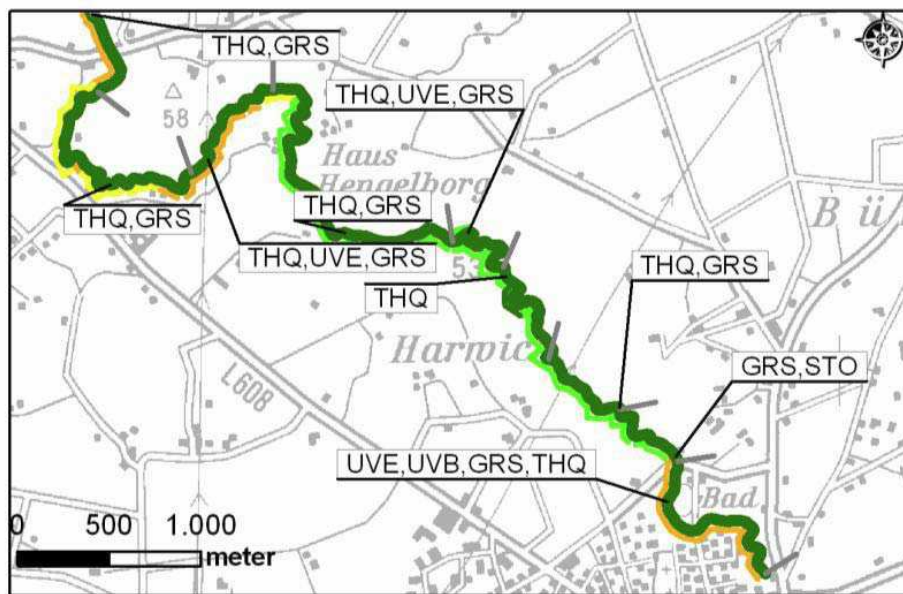

**Berkel (subarea)**

**quality after developing time**

- class 1
- class 2
- class 3
- class 4
- class 5
- class 6
- class 7

**current quality**

- class 1
- class 2
- class 3
- class 4
- class 5
- class 6
- class 7

- GRS improvement of bank width
- STO rocks or other elements for disturbing the flow
- THQ deadwood for improving the cross section
- UVB removal of bank fixation
- UVE support for bank vegetation
- Display of the measures without removal of anthropogenic migration barriers

Fig. 4. Map with the results of the DSS for the Berkel (subarea)

Figure 3 shows the morphological quality for a certain reach of the River Berkel before and after implementing the proposed improvement measures. The given codes indicate the proposed improvement combination measure for the segments between the gray 'hatch'-bars. The thick line on the right (here completely green) shows the expected morphological quality class 18 years after the implementation of the proposed morphological measures. The thin line on the left side of the river (here orange, yellow and light green) expresses the

current morphological quality, thus before the measures are implemented. The DSS is currently being implemented at several regional river authorities in NRW.

### 8. Fuzzy-Rule-Based habitat model for Salmon

In order to enable decision makers to investigate the impact of river restoration on its suitability for fish habitat, a separate Salmon habitat model has been developed. The model can be used to assess water river segments based on their morphological, biological and chemical characteristics. Fourteen indicators have been used as model inputs to estimate the suitability index for each segment. As listed in Table 3, eight morphological indicators as outputs of the DSS have been considered to be inputs for the fuzzy model. Other six biochemical indicators have been considered as model inputs. Selecting these indicators was based on interviews and questionnaires for fish experts to identify the most significant ones for Salmon habitat. The model aggregates and assesses the input indicators in four steps to reach the suitability index of river segment under investigation.

Input Indicators	Intermediate Indicators A	Intermediate Indicators B	Intermediate Indicators C	Model Output
Natural elements	Longitudinal Profile	Bed characteristics	Morphological Structure	Suitability Index
Anthropogenic migration barrier				
Type and spreading of substrates	Bed Structure			
Bed fixation				
Cross-section form	Cross Section	Bank characteristics		
Width variation				
Natural characteristics	Bank structure			
Bank characteristics				
Saprobic Index			Biological and chemical water quality	
PH- Value	Water Quality A	Chemical and Physical parameters		
Water Temperature				
Ammonic Concentration				
oxygen concentration in surface water	Water Quality B			
oxygen concentration in interstitial water				

Table 3. Input, Intermediate, and Output Indicators of the Salmon Habitat Model

The stepwise aggregation process has been carried out using fuzzy-rule-based approach. Figure 5 shows the structure of the model that has been developed using MATLAB Fuzzy-

Logic Toolbox in combination with Simulink. The gray boxes in the figure represent the model inputs. The coloured boxes are the rule-blocks that aggregate the input indicators to estimate the suitability index (blue block on the right side).

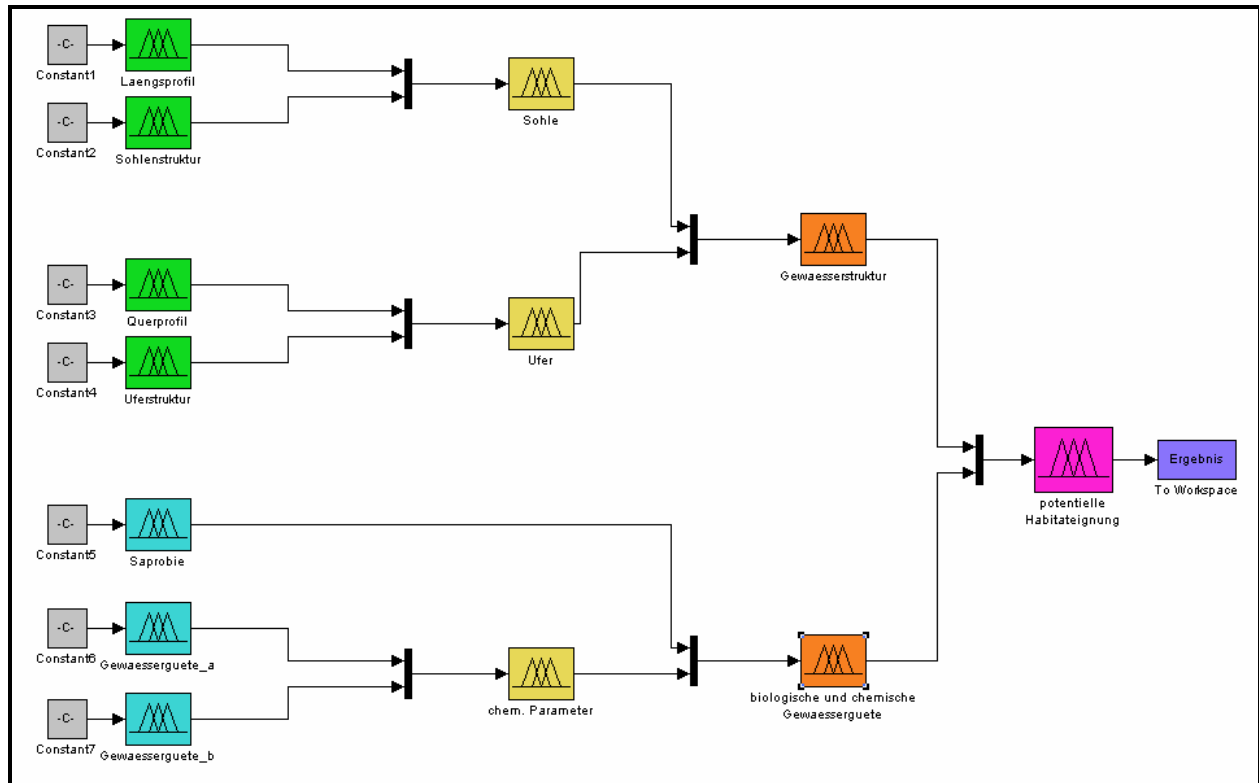

Fig. 5. Structure of the Fuzzy-Rule-Based Habitat Model

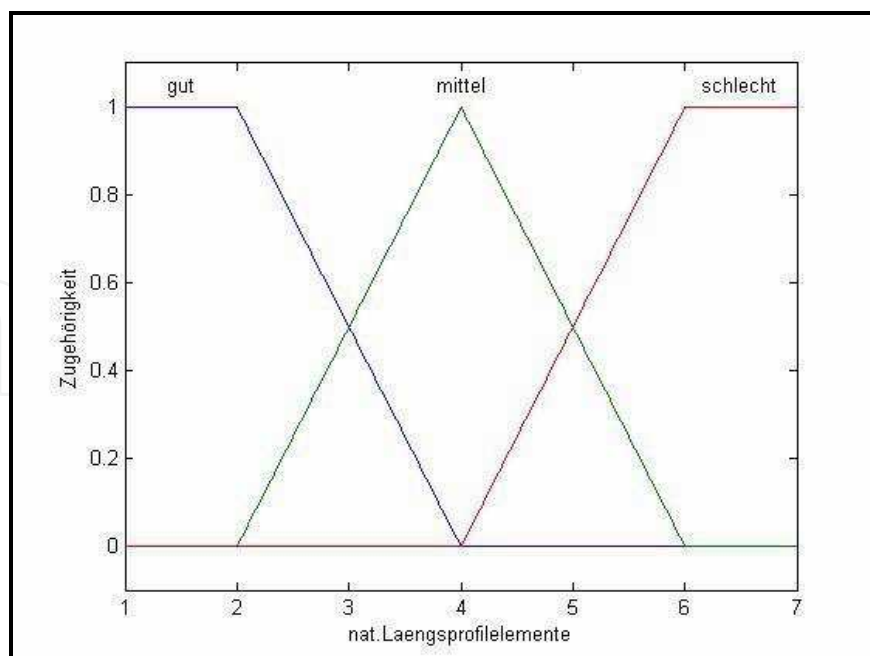

Fig. 6. Membership Functions of the Indicator Natural Elements

Each of the input and intermediate indicators are represented as linguistic variables with three terms. The output indicator “Habitat Suitability Index” has five terms. Each term is

described either by triangular or trapezoidal membership function. The membership functions were initially spaced equally and then shifted and modified according to the opinion of fish experts and literature review. Figure (6) shows an example of the input linguistic variable "Natural elements" that is divided into three different membership functions. The membership function "good/gut" has a degree of one from 1 through 2. This membership value declines to zero when the value is 4. The same is followed to construct both membership functions middle/mittel and bad/schlecht. The same approach is followed for all indicators.

Selecting linguistic terms that are meaningful for users are considered while constructing the membership functions. For instance, the terms of the "temperature" are considered as follows: "cold, optimum, hot". Using such membership functions, the model inputs will be transformed to linguistic terms (fuzzified). For example, an input value of 6 means that the indicator "natural element" is classified as "good" with a membership degree of 1 (100%). Fuzzy rules are then used to stepwise aggregate and assess the input terms in order to reach the overall goal (habitat suitability index). For instance, a rule that is used to assess and aggregate the indicators (Natural Elements and Anthropogenic migration barrier) into one intermediate indicator A (Longitudinal Profile) can be written as follows:

<b>IF</b>	Natural Elements	<b>IS</b>	good
<b>AND</b>	Anthropogenic migration barrier	<b>IS</b>	good
<b>THEN</b>	Longitudinal Profile	<b>IS</b>	good

In the rule-blocks, each rule has got a weight (from 0 to 1) that reflects its significance. Initially, all possible rules are generated and then assessed to get the suitable weight. This process is also carried out by fish experts and researchers. The centre of maximum method is then used to transform the linguistic terms of the fish habitat suitability index into crisp value (defuzzification process). The result of the model is a crisp suitability value of the assessed river segment that is between 0 and 1.

The first version of the habitat model was validated using field data for the water streams Menden, Eitorf and Weidenau. For the Menden and Eitrof the used data-sets are for the years 1992, 1994, 1997 and 2002. Input data for the period 1996 till 2002 have been used for the Weidenau. Annual average values for the chemical and biological indicators have been used to generate different scenarios for the input parameters. To validate the model output (habitat suitability index for salmon) the fish population in each water body in the same year has been used as reference for validating the model results. The model has resulted satisfactory correlation between habitat index and fish population.

## 9. Conclusion

The small and medium-sized watercourses in NRW are strongly affected by human activities. The developed DSS is a step towards the successful implementation of the EU WFD in NRW. It supports the planning of the morphological programme of measures in NRW. The system makes the knowledge of experts available for decision makers at ministerial and regional levels. This allows regional decision makers to plan restoration measures. Taking the cost factor into consideration allows decision makers at ministerial level to allocate morphological restoration resources and manpower within NRW.

The development of the salmon model is necessary to estimate the impact of restoration measures on fish habitat. The results of the first development phase have shown the



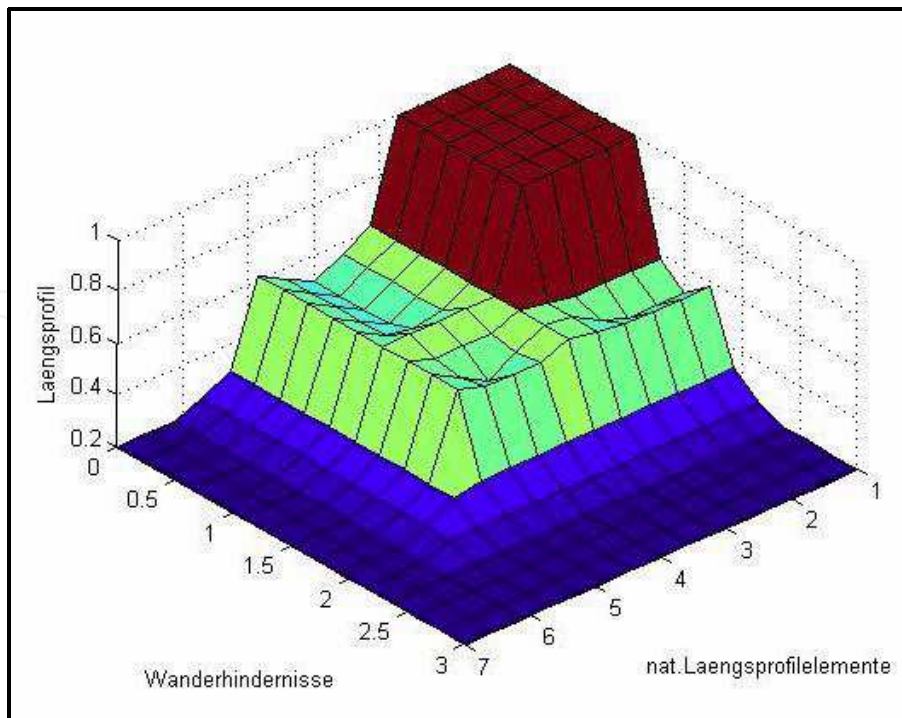

Fig. 7. Graphic Illustration of the Relation between the indicators “Natural Elements, Anthropogenic migration barrier and Longitudinal Profile.

Location	Year	Anthropogenic migration substrates	Anthropogenic	Art und Verteilung der Substrate	Bed Fixation	cross section form	width variation	bank natural cover	Bank Characteristics	Saprobic Index	PH-Value	Temperature	Ammonic Concentration	Oxygen concentration in surface water	Oxygen concentration in interstitial water	Fish Population	Habitat Suitability Index
Menden	1992	4	0	3	3	4	45.9	4	4.5	2.1	7.8	12.9	0.02	10.8	9.81	75	<b>0.4321</b>
Menden	1994	4	0	3	3	4	60.1	4	4.5	2.3	8.48	12	0.02	9.59	8.59	66	<b>0.3721</b>
Menden	1997	4	0	3	3	4	32.3	4	4.5	2.71	8.17	12.2	0.02	12.5	11.5	10	<b>0.2632</b>
Menden	2002	4	0	3	3	4	68.2	4	4.5	2.12	7.33	14.1	0.03	12.1	11.1	5	<b>0.1921</b>
Eitorf	1992	1	0	1	1	2	24.8	3	3.5	2.2	7.4	21	0.04	7.6	6.6	53	<b>0.2632</b>
Eitorf	1994	1	0	1	1	2	34	3	3.5	2.2	8.1	24.8	0.04	6.9	5.9	47	<b>0.2632</b>
Eitorf	1997	1	0	1	1	2	18.2	3	3.5	1.85	8.3	22	0.03	9.2	8.2	7	<b>0.2122</b>
Eitorf	2002	1	0	1	1	2	39.6	3	3.5	1.87	8.3	19.1	0.03	9.05	8.05	3	<b>0.1889</b>
Weidenau	1996	5	1	5	5	6	1.29	4	7	2.5	7.7	14	0.03	10	9	13	<b>0.2305</b>
Weidenau	1997	5	1	5	5	6	1.1	4	7	2	7.9	14.9	0.08	10.3	9.3	2	<b>0.1831</b>
Weidenau	1998	5	1	5	5	6	2.94	4	7	2	8.4	20.4	0.03	9.1	8.1	2	<b>0.1831</b>
Weidenau	1999	5	1	5	5	6	2.21	4	7	2.5	8.7	19.3	0.05	12.7	11.7	2	<b>0.1831</b>
Weidenau	2000	5	1	5	5	6	2.06	4	7	2	8.2	14.6	0.05	10.3	9.3	3	<b>0.1831</b>
Weidenau	2001	5	1	5	5	6	2.22	4	7	2	8.1	11.3	0.05	10.3	9.3	1	<b>0.1831</b>
Weidenau	2002	5	1	5	5	6	2.99	4	7	2.5	7.9	11.3	0.05	10.1	9.1	1	<b>0.1831</b>

Table 4. Calculated Habitat Suitability Index for the Menden, Eitorf and Weidenau water streams

applicability of fuzzy logic to develop ecohydrological models that overcome the problem of associated uncertainty of indicators. The model enables mixing qualitative and quantitative

data in a strict fuzzy mathematical framework. It was possible to integrate the qualitative knowledge of involved researchers and experts during constructing both membership functions and rule-bases.

Further development of the DSS should include coupling it with the fuzzy fish model and water quality model. It should also take into consideration bigger river sizes social aspects, collecting more restoration data for validating and improving the rule base as well as modelling the interaction between river segments.

## 10. References

- Alberta Government (Transportation department) (2003): Fish Habitat Manual. <http://www.trans.gov.ab.ca>.
- Bender, M., C. Katopodis, S. P. Simonovic 1992. A Prototype Expert System for Fishway Design. *Environmental Monitoring and Assessment* 23:115-127, 1992.
- Cortés, U., M. Sánchez-Marrè, L. Cecaronni, I. R.-Roda, and M. Poch, *Environmental - Decision Support Systems, Applied Intelligence* 13(1),77-91, 2000.
- Domanski, B. 1989. A PROLOG-based Expert System for Tuning MVS/XA. *Performance Evaluation Review* Vol. 16 #2-4 February 1989.
- European Parliament (2000) EU Water Framework Directive. *Official Journal*, L 327, 1-73
- Fisher, S.G., Grimm, N.B., Marti, E., Holmes, R.M. and Jones, J.B., 1998. Material spiraling in stream corridors: A telescoping ecosystem model. *Ecosystems*, 1(1): 19-34.
- German Working Group of the Federal States (LAWA) (1998): *Gewässerstrukturgütekartierung in der Bundesrepublik Deutschland, Verfahren für kleine und mittelgroße Fließgewässer*.
- German ministry of Environment and Conservation, Agriculture and Consumer Protection of the State of North Rhine-Westphalia (MUNLV NRW) (2005): *Erfolgskontrolle von Maßnahmen zur Unterhaltung und zum naturnahen Ausbau von Fließgewässern*. Köln.
- Hauer, C., M. Liedermann and H. Habersack (2006) *The Influence of Human Impact to River morphology and aquatic ecology at the Austrian Kamp River*. Vol. 8, 07430, 2006. European Geosciences Union 2006. SRef-ID: 1607-7962/gra/EGU06-A-07430
- Montgomery, D.R. 2006. *Geomorphology and Restoration Ecology JoUrnal of Contemporary Water researCh & education issUe 134, pages 16-19, JULy 2006*
- North Rhine-Westphalia State Environment Agency (LUA NRW) (2002): *Gewässergütebericht 2001 Nordrhein-Westfalen, Berichtszeitraum 1995 - 2000*, Essen.
- North Rhine-Westphalia State Environment Agency (LUA NRW) (2003): *Strukturgütedaten NRW der kleinen und mittelgroßen Fließgewässer*.
- Scherer, V. R., R. Twelbeck and C. Linnenweber 2006. *Gewässerstrukturgüte und Habitatqualität für Fischzönosen*. *Wasserwirtschaft*, Vol. 96, 26-31.
- Schülter, M., N. Rüger, A.G. Savitsky, N.M. Novikova, M. Matthies, H. Leith 2006. *TUGAI: AN Integrated Simulation Tool for Ecological Assessment of Alternative Water Management Strategies in a Degraded River Delta*. *Springer Science - Environmental Management* 38: 238-653 2006.
- Umwelt Bundes Amt (2005) *Water Framework Directive - Summary of River Basin District Analysis 2004 in Germany*. Bonifatius, Paderborn.
- Vicente, D., Vellido,A., Marti,E., Comas,J., Rodríguez-Roda,I. (2004). *Exploration of the ecological status of Mediterranean rivers: clustering, visualizing and reconstructing streams data using Generative Topographic Mapping*. *Data Minig V, A,Zanasi,N.F.F. Ebecken & C.A. Brebbia (editors)*.



## **Decision Support Systems Advances in**

Edited by Ger Devlin

ISBN 978-953-307-069-8

Hard cover, 342 pages

**Publisher** InTech

**Published online** 01, March, 2010

**Published in print edition** March, 2010

This book by In-Tech publishing helps the reader understand the power of informed decision making by covering a broad range of DSS (Decision Support Systems) applications in the fields of medical, environmental, transport and business. The expertise of the chapter writers spans an equally extensive spectrum of researchers from around the globe including universities in Canada, Mexico, Brazil and the United States, to institutes and universities in Italy, Germany, Poland, France, United Kingdom, Romania, Turkey and Ireland to as far east as Malaysia and Singapore and as far north as Finland. Decision Support Systems are not a new technology but they have evolved and developed with the ever demanding necessity to analyse a large number of options for decision makers (DM) for specific situations, where there is an increasing level of uncertainty about the problem at hand and where there is a high impact relative to the correct decisions to be made. DSS's offer decision makers a more stable solution to solving the semi-structured and unstructured problem. This is exactly what the reader will see in this book.

### **How to reference**

In order to correctly reference this scholarly work, feel free to copy and paste the following:

Hani Sewilam and Heribert Nacken (2010). Rule-Based System for Morphological and Ecohydrological Decision Making, Decision Support Systems Advances in, Ger Devlin (Ed.), ISBN: 978-953-307-069-8, InTech, Available from: <http://www.intechopen.com/books/decision-support-systems-advances-in/rule-based-system-for-morphological-and-ecohydrological-decision-making>

**INTECH**  
open science | open minds

### **InTech Europe**

University Campus STeP Ri  
Slavka Krautzeka 83/A  
51000 Rijeka, Croatia  
Phone: +385 (51) 770 447  
Fax: +385 (51) 686 166  
[www.intechopen.com](http://www.intechopen.com)

### **InTech China**

Unit 405, Office Block, Hotel Equatorial Shanghai  
No.65, Yan An Road (West), Shanghai, 200040, China  
中国上海市延安西路65号上海国际贵都大饭店办公楼405单元  
Phone: +86-21-62489820  
Fax: +86-21-62489821

© 2010 The Author(s). Licensee IntechOpen. This chapter is distributed under the terms of the [Creative Commons Attribution-NonCommercial-ShareAlike-3.0 License](#), which permits use, distribution and reproduction for non-commercial purposes, provided the original is properly cited and derivative works building on this content are distributed under the same license.

IntechOpen

IntechOpen