

We are IntechOpen, the world's leading publisher of Open Access books Built by scientists, for scientists

4,800

Open access books available

122,000

International authors and editors

135M

Downloads

Our authors are among the

154

Countries delivered to

TOP 1%

most cited scientists

12.2%

Contributors from top 500 universities

**WEB OF SCIENCE™**Selection of our books indexed in the Book Citation Index
in Web of Science™ Core Collection (BKCI)

Interested in publishing with us?
Contact book.department@intechopen.com

Numbers displayed above are based on latest data collected.
For more information visit www.intechopen.com



Simultaneous Pick-up and Delivery Decision Support Systems

Cevriye Gencer¹, Emel Kızılkaya Aydoğan² and Suna Çetin³

¹Department of Industrial Engineering, Faculty of Engineering and Architecture,
Gazi University,

²Department of Industrial Engineering, Faculty of Engineering, Erciyes University,

³Department of Industrial Engineering, Faculty of Engineering, Kırıkkale University
Turkey

1. Introduction

The problems concerning the distribution of goods between depots and final users are known as Vehicle Routing Problems (VRP). Dantzig & Ramser (1959) introduced VRP. The authors described a real world application and proposed the first mathematical programming formulation and algorithmic approach for the solution of the problem.

Let $G = (V, A)$ is a graph where $V = \{v_0, v_1, \dots, v_n\}$ is a vertex set and $A = \{(v_i, v_j) : v_i, v_j \in V, i \neq j\}$ is an arc set. v_0 represents depot and v_i represents customers.

Every customer has a nonnegative demand q_i .

VRP consist of finding a collection of vehicle routes with minimum cost such that (1) each route starts and end at the depot, (2) each customer is visited exactly once by one vehicle, (3) the total demand of each route does not exceed vehicle capacity, (4) the total duration of each route (including travel and service times) does not exceed a present limit, (5) the total routing cost is minimized. Typical applications of VRP are solid waste collection, street cleaning, school bus routing, transportation of handicapped persons etc.

Variants of VRP, which have some extensions on basic VRP, are given in Figure 1 (Toth & Vigo, 2002).

In vehicle routing problems with pick up and delivery (VRPPD) every customer has two demands as pick up demand (pi) and delivery demand (di). Delivery demand refers to amount of goods transporting from depot to customer, pickup demands refers to amount of goods transporting from customer to depot. VRPPD is classified into three groups due to servicing delivery and pick up demands as

- Delivery first- pickup second,
- Mixed pickups and deliveries,
- Simultaneous pickups and deliveries.

Delivery first- pickup second VRPPD: Customers are visited more than once. Goods are transported from depot to delivery customers then pick up customers are visited and goods are transported back to the depot. There is precedence between delivery and pick up customers.

Source: Decision Support Systems, Advances in, Book edited by: Ger Devlin,
ISBN 978-953-307-069-8, pp. 342, March 2010, INTECH, Croatia, downloaded from SCIYO.COM

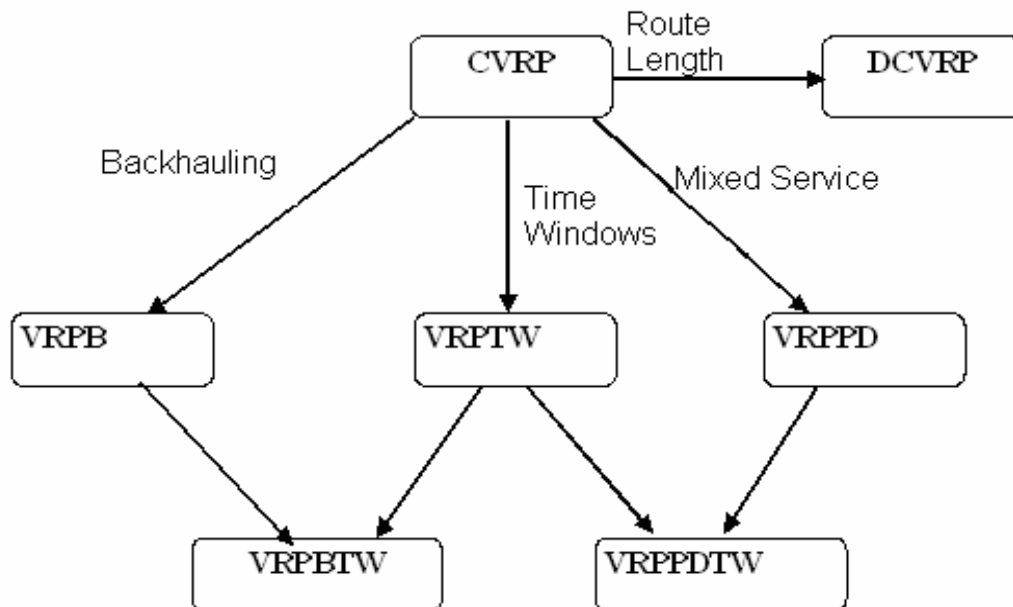

Fig. 1. The basic problems of the VRP

Mixed pickups and deliveries VRPPD: There is not precedence between delivery and pick up customers in. Delivery demand and pick up demands is serviced in a mixed sequence. Customers are visited more than once.

Simultaneous pickups and deliveries VRPPD: Delivery and pick up demand are serviced simultaneously (this problem is denoted as VRPSPD). Customers are visited only once.

VRPSPD is NP -hard combinatorial optimization problem as it is a version of VRP. VRPSPD consists of finding a set of routes such that,

- Each route starts and ends at the depot,
- Each customer is visited by one vehicle,
- Pick up and delivery demands are totally satisfied,
- Through the route load of vehicle does not exceed vehicle capacity,
- Total cost is minimized.

VRPSPD is encountered in real life. In the soft drink industry full bottles are transported from depot to markets, empty bottles are returned back to the depots in the grocery industry goods flow from depot to market while outdated products flow to depots are examples for VRPSPD.

VRP classified into two groups considering properties of vehicles as capacity, fixed and variable cost. If all vehicles have same capacity, variable and fixed cost values this problem is called as homogeneous VRP; otherwise, means one or more of these properties are different for a vehicle, problem is known as heterogeneous VRP (HVRP).

In the literature, three HVRP versions have been studied. The first one was introduced by Golden, in which variable costs are uniformly given over all vehicle types with the number of available vehicles assumed to be unlimited for each type. This version is also called the vehicle fleet mix (VFM), the fleet size and mix VRP or the fleet size and composition VRP.

The second version considers the variable costs, dependent on vehicle type, which is neglected in the first version. This version is the one dealt with in this paper, and referred to as the HVRP, the VFM with variable unit running costs or the mix fleet VRP. The third one, called the VRP with a heterogeneous fleet of vehicles or heterogeneous fixed fleet VRP, generalizes the second version by limiting the number of available vehicles of each type (Choi & Tcha, 2007).

2. Literature review of VRPSPD

VRPSPD was introduced by Min (1989). He proposed an algorithm for transportation of books between libraries, with one depot, two vehicles and 22 customers. His algorithm is based on cluster first-route second approach. Dethloff (2001) proposed mathematical formulation for the problem and also he develops an insertion-based heuristic to solve the problem. The insertion criterion takes into account three metrics: travel distance, residual capacity, and radial surcharge. Nagy & Salhi (2005) presented a number of heuristics for vehicle routing problem with picks up and deliveries, which are capable of solving both VRPSPD, and mixed VRPPD. Bianchessi & Righini (2007) presented and compare performance of constructive algorithms, local search and tabu search algorithms. Tang Montane & Galvao (2006) proposed a mathematical formulation and a tabu search algorithm, which is intensified and diversified by the use of frequency penalization scheme for VRPSPD. Zachariadis et al. (2009a) proposed a hybrid metaheuristic approach based on tabu search and guided local search. Gajpal & Abad (2009) presented an ant colony system algorithm for VRPSPD. Ai & Kachitvchyanukul (2009) proposed mathematical formulation and a particle swarm optimization algorithm for VRPSPD. The formulation is generalizations of mathematical formulation of VRPSPD literatures Min, Dethloff, Tang and Galvao. Chen & Wu (2006) proposed a hybrid metaheuristic method based on record-to-record travel tabu list and route improvements routines. Zachariadis et al. (2009b) presented an adaptive memory programming methodology algorithm for the VRPSPD.

3. Decision support systems

The limitations of OR algorithms alone to fully meet the needs of business decision-makers became obvious in a number of fields and this led to the development of the concept of a DSS. A Decision Support System (DSS) assists management decision making by combining data, sophisticated analytical models and tools, and user-friendly software into a single powerful system that can support semi structured or unstructured decision making. The main purpose of DSS is not to make a decision but to assist making a decision.

Power (2001) has presented an expanded decision support system framework containing the model driven DSS, data driven DSS, communications-driven DSS, document driven DSS and web-based DSS.

Model-driven DSS emphasizes access to and manipulation of financial, optimization and/or simulation models. Model-driven DSS use limited data and parameters provided by decision makers to aid decision makers in analyzing a situation (Power, 2002). Data-driven DSS emphasizes access to and manipulation of a time-series of internal company data and sometimes external and real-time data. Communications-driven DSS use network and communications technologies to facilitate decision-relevant collaboration and communication (Power, 2002). Document-driven DSS uses computer storage and processing

technologies to provide document retrieval and analysis. Knowledge-driven DSS can suggest or recommend actions to managers. These DSS are person-computer systems with specialized problem-solving expertise (Power, 2002). Power (1998) defined a Web-based decision support system as a computerized system that delivers decision support information or decision support tools to a manager or business analyst using a "thin-client" Web browser like Netscape Navigator or Internet Explorer.

In our chapter, we will use model-driven DSS and interfaces are written in Visual Basic 6.0, and computations are executed by a program coded in C++ 6.0. This DSS provides the user a simple data entry and result processing environment.

4. The illustrative applications for DSS

The applications related to the use of DDS with homogenous fleet VRPSPD and heterogeneous fleet VRPSPD are included in this chapter.

4.1. DSS for homogeneous fleet VRPSPD

Same or different vehicle characteristics in VRP define a new VRP. Homogeneous fleet VRP is the VRP adopted in case the vehicles have the same capacity, fixed and variable costs. Since NP-hard structure of VRP and variance of its vehicle characteristics make this structure more complex, generally homogeneous structure is studied in the literature.

Application 1: A decision support system application, which is based on simultaneous pickup and delivery vehicle routing models for transporting the domestic transfer demands reported to the Transportation Command (Gencer & Yaşa, 2007).

Within the Transportation Command, seven permanent shuttle routes are assigned in nationwide and, the weekly transportation service on these routes is organized. Assigned permanent shuttle routes are as follows:

1. Shuttle A (1860 km.)
2. Shuttle B (2030 km.)
3. Shuttle C (824 km)
4. Shuttle D (1920 km.)
5. Shuttle E (1570 km)
6. Shuttle F (1550 km.)
7. Shuttle G (983 km)

Present Condition

The route of shuttle and the number of routes are established in time considering the need. This number is not questioned scientifically. While assigning the routes, it is regarded to have a factory command on each of the routes; however, the amount of demand is not taken into evaluation. Routes to be followed are permanent; demands are variable. Consequently, routes should change according to the varying demands.

Suggested DSS

The aim of this application is to maintain the VRP 2.0 route program decision support system, which would minimize the distance travelled for shuttle tours and the number of vehicles to be used. The software is developed on the basis of the mathematical model of Dethloff (Dethloff, 2001). Dethloff's algorithm is an insertion basis heuristic algorithm. Transportation Command aims to ensure a safe transportation at a minimum cost.

Problem Assumptions

Demands are known beforehand (before the vehicles start their routes)

Demands are covered from one depot.

Depot is the starting and final point of every vehicle.

No transportation is made between the points on the route.

Pick-up and delivery demands of every customer are serviced simultaneously

Each customer should be visited for once.

There are enough vehicles for transportation.

DSS main components of VRP 2.0 Route program are shown in Figure 2.

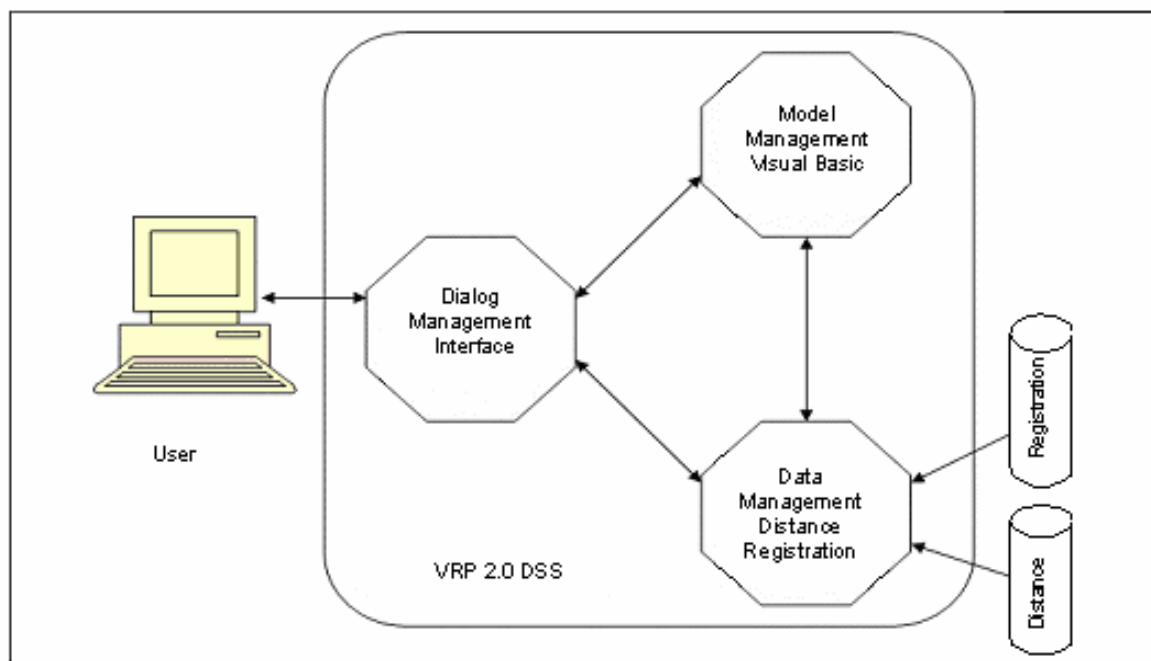

Fig. 2. DSS's Main Components of the VRP 2.0 Route Program

VRP2.0 program is composed of two interfaces, which enable to find the shortest routes and to computerize the routes. The first interface is the interface into which data and calculation criteria are entered. The amount of supply to be delivered to and picked-up from the provinces and capacity of vehicle to be used are entered into this interface. In the program, there are boxes for the vehicles with a capacity of 15m³, 30 m³, 45 m³, 60 m³. While different capacities are defined for the vehicles, homogeneous fleet vehicles are used. Considering the possible use of different vehicles in future, the choice of "other" is added which enables manual entry into the system. During data entry, the program automatically collects delivery and pick-up amounts that have been entered till "load to be delivered" and "load to be picked-up" boxes. GAMA and LAMDA values, which show the penalty and bonus coefficients, are entered in the form of 0 and 1. After all data and calculation criteria are entered; calculation button is pushed and calculation process starts. The calculation interface of the program is given in Figure 3. When the calculation process is completed, the results are displayed in the final interface shown in Figure 4. This interface presents the number of routes and the provinces creating the route respectively, the length of that route and the information of the total amount of load to be delivered and picked-up on the route;



Fig. 3. Computation Interface of the VRP 2.0 Program

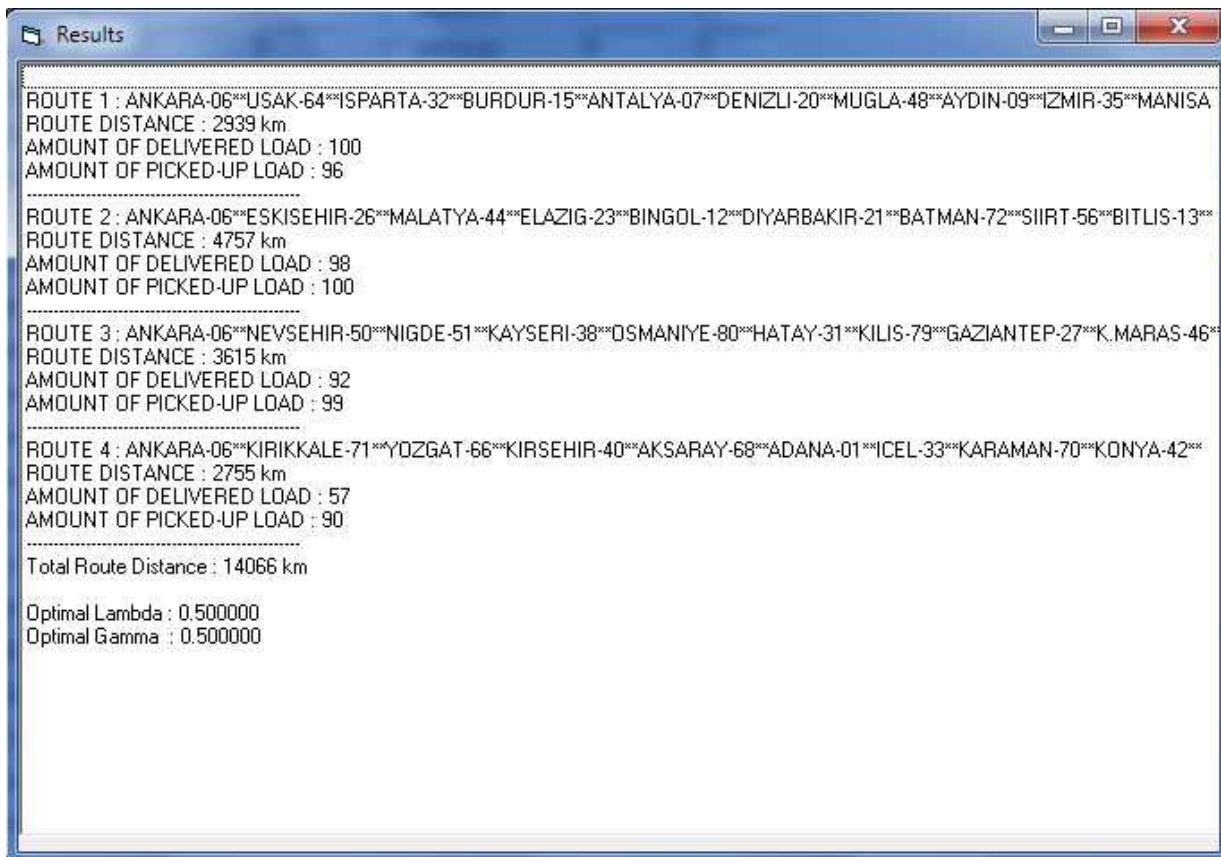

Fig. 4. Conclusion Interface of the VRP2.0 Program

moreover the total length of all routes and the penalty and bonus coefficients related to the routes. When double-clicked, any of the lines in the final interface is displayed in a message box format. Figure 5, for instance, shows which provinces are involved in the first route respectively. First route is: Ankara - Uşak - Isparta - Burdur - Antalya - Denizli - Muğla - Aydın - İzmir - Manisa - Balıkesir - Çanakkale - Edirne - Kırklareli - Tekirdağ - İstanbul - Bursa - Yalova - Kocaeli - Sakarya - Düzce - Bolu - Ankara.

In VRP2.0 software, interfaces are derived by visual basic 6.0 programming language; calculations are derived via a program that is coded in C++ 6.0 language.

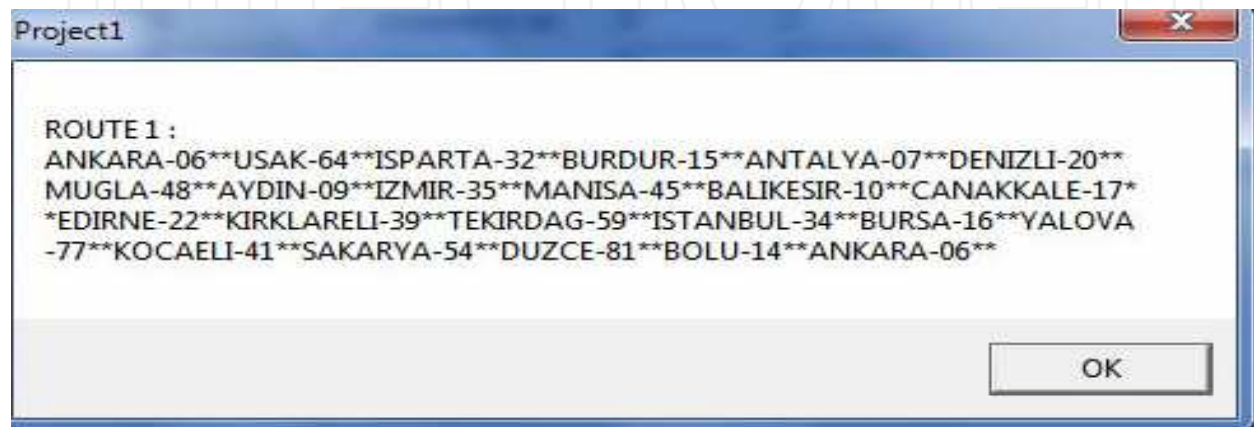

Fig. 5. Route Message Box of the VRP2.0 Program

4.2 DSS for heterogonous fleet VRPSPD

Although it is encountered frequently in theory, vehicle fleets of application are generally heterogeneous rather than homogeneous. In other words; vehicle fleets are composed of vehicles with different capacity, fixed and variable costs or specific containers. Consequently; in real life applications, heterogeneous fleet vehicle routing problems are encountered. However; since the resolution of heterogeneous fleet VRP is difficult, it is not regarded as an issue to be studied by the researchers. Therefore, only limited numbers of studies have been conducted on this issue to date.

Application 2: A decision support system application which is based on heterogeneous fleet vehicle routing problem with simultaneous pick up and delivery for transporting the domestic transfer demands reported to the Transportation Command (Özkütük, 2008).

In addition to the assumptions in Application 1, the assumptions below are defined.

- There is no heterogeneous vehicle fleet in depot
- Every type of vehicle in depot is restricted.
- Fixed and variable costs of every type of vehicle are variable and different from each other.

Flowchart diagram for Application 2 is shown in Figure 6.

“Calculate all combinations of the vehicles in each route” box in Figure 6 is a result of heterogeneous VRP of problem. The third type heterogeneous fleet VRP “the number of vehicles from every type is restricted and every type of vehicle has a different cost”, which is identified in literature, was studied during the study. Determining the proposed algorithm vehicle fleet compound is developed on the basis of Taillard’s (1996) algorithm and, comparison of costs method is applied.

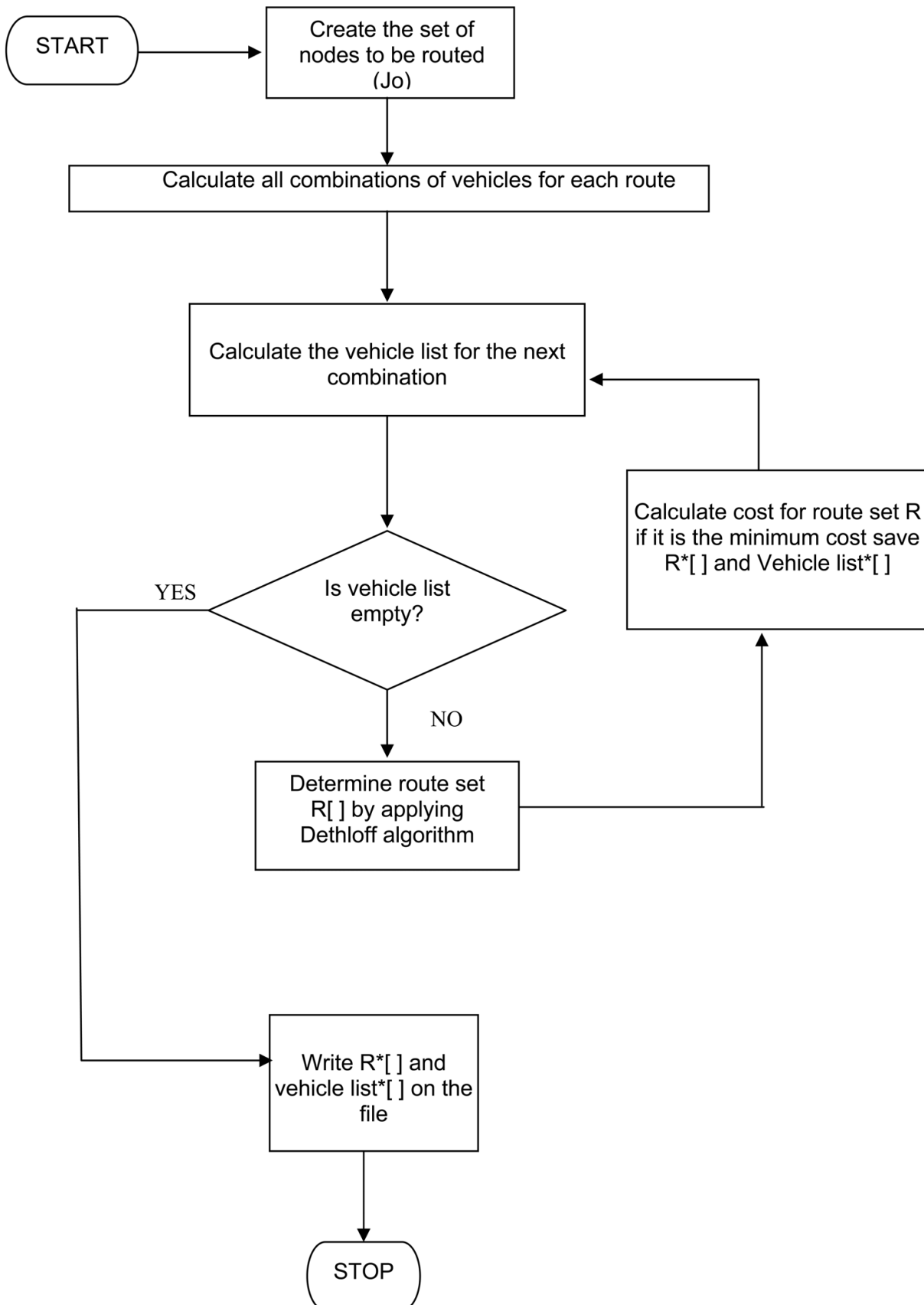

Fig. 6. Flowchart of proposed algorithm

The DSS interfaces related to the problem was prepared using Visual Basic 6.0 and the computation algorithm is coded using C++. The program has two main interfaces; the first one is where the data is entered and the second one is where results are presented. The input interface is where data and calculation criteria is entered by the user. Here, delivery and pick up nodes are determined preliminarily, and pick up and delivery demand of each customer is entered. Total delivery demand and total pick up demand are computed automatically as the data is entered. In capacity option, numbers of each vehicle type, capacity, fixed and variable cost of each vehicle are entered. If total delivered and total picked up load is more than vehicle capacity, a warning with red character as “total vehicle capacity is not enough” is written in Route Information option and program does not carry on calculation. After entering material and vehicle information, penalty and bonus coefficients gamma and lamda respectively, which are between 0 and 1 are entered in computation coefficient option. Clicking computation button starts the calculation. In order to avoid repetitive data entry by the user if repeating material transfers exist, two buttons namely “Save” and “Load” is located at the program menu. After entering the data using “Save” button all transfer information is registered and “Load” button may be used to call same data to the program. Input interface of the program is given in Figure 7.

Customer	Deliver	Pick-up	Customer	Deliver	Pick-up	Customer	Deliver	Pick-up
<input type="checkbox"/> ADANA-01	0	0	<input type="checkbox"/> EDİRNE-22	0	0	<input type="checkbox"/> KÜTAHYA-43	0	0
<input type="checkbox"/> ADIYAMAN-02	0	0	<input checked="" type="checkbox"/> ELAZIĞ-23	18	13	<input checked="" type="checkbox"/> MALATYA-44	10	21
<input checked="" type="checkbox"/> AFYON-03	28	33	<input checked="" type="checkbox"/> ERZİNCAN-24	23	23	<input type="checkbox"/> MANİSA-45	0	0
<input type="checkbox"/> AĞRI-04	0	0	<input checked="" type="checkbox"/> ERZURUM-25	23	5	<input type="checkbox"/> MARDİN-47	0	0
<input checked="" type="checkbox"/> AKSARAY-68	5	0	<input type="checkbox"/> ESKİŞEHİR-26	0	0	<input type="checkbox"/> MUĞLA-48	0	0
<input type="checkbox"/> AMASYA-05	0	0	<input type="checkbox"/> GAZİANTEP-27	0	0	<input type="checkbox"/> MUŞ-49	0	0
<input checked="" type="checkbox"/> ANKARA-06	0	0	<input type="checkbox"/> GİRESUN-28	0	0	<input type="checkbox"/> NEVŞEHİR-50	0	0
<input type="checkbox"/> ANTALYA-07	0	0	<input type="checkbox"/> GÜMÜŞHANE-29	0	0	<input checked="" type="checkbox"/> NIĞDE-51	10	21
<input type="checkbox"/> ARDAHAN-75	0	0	<input type="checkbox"/> HAKKARİ-30	0	0	<input type="checkbox"/> ORDU-52	0	0
<input type="checkbox"/> ARTVIN-08	0	0	<input type="checkbox"/> HATAY-31	0	0	<input type="checkbox"/> OSMANIYE-90	0	0
<input type="checkbox"/> AYDIN-09	0	0	<input type="checkbox"/> İĞDIR-76	0	0	<input type="checkbox"/> RİZE-53	0	0
<input checked="" type="checkbox"/> BALIKESİR-10	25	0	<input type="checkbox"/> İSPARTA-32	0	0	<input checked="" type="checkbox"/> SAKARYA-54	40	15
<input type="checkbox"/> BARTIN-74	0	0	<input checked="" type="checkbox"/> İÇEL-33	37	10	<input type="checkbox"/> SAMSUN-55	0	0
<input type="checkbox"/> BATMAN-72	0	0	<input checked="" type="checkbox"/> İSTANBUL-34	33	43	<input type="checkbox"/> SİİRT-56	0	0
<input type="checkbox"/> BAYBURT-69	0	0	<input checked="" type="checkbox"/> İZMİR-35	37	70	<input type="checkbox"/> SİNOP-57	0	0
<input type="checkbox"/> BİLECİK-11	0	0	<input type="checkbox"/> K. MARAŞ-46	0	0	<input checked="" type="checkbox"/> SİVAS-58	10	0
<input type="checkbox"/> BİNGÖL-12	0	0	<input type="checkbox"/> KARABÜK-78	0	0	<input type="checkbox"/> ŞANLIURFA-63	0	0
<input type="checkbox"/> BITLİS-13	0	0	<input type="checkbox"/> KARAMAN-70	0	0	<input type="checkbox"/> ŞİRİNAK-73	0	0
<input checked="" type="checkbox"/> BOLU-14	3	0	<input type="checkbox"/> KARS-36	0	0	<input type="checkbox"/> TEKİRDAĞ-59	0	0
<input type="checkbox"/> BURDUR-15	0	0	<input type="checkbox"/> KASTAMONU-37	0	0	<input type="checkbox"/> TOKAT-60	0	0
<input checked="" type="checkbox"/> BURSA-16	5	0	<input checked="" type="checkbox"/> KAYSERİ-38	57	30	<input type="checkbox"/> TRABZON-61	0	0
<input type="checkbox"/> ÇANAKKALE-17	0	0	<input type="checkbox"/> KIRIKKALE-71	0	0	<input type="checkbox"/> TUNCELİ-62	0	0
<input type="checkbox"/> ÇANKIRI-18	0	0	<input type="checkbox"/> KIRKLARELİ-39	0	0	<input type="checkbox"/> VAN-65	0	0
<input type="checkbox"/> ÇORUM-19	0	0	<input type="checkbox"/> KIRŞEHİR-40	0	0	<input type="checkbox"/> YALOVA-77	0	0
<input type="checkbox"/> DENİZLİ-20	0	0	<input type="checkbox"/> KİLİS-79	0	0	<input type="checkbox"/> YOZGAT-66	0	0
<input checked="" type="checkbox"/> DİYARBAKIR-21	25	30	<input checked="" type="checkbox"/> KOCAELİ-41	2	12	<input type="checkbox"/> UŞAK-64	0	0
<input type="checkbox"/> DÜZCE-81	0	0	<input checked="" type="checkbox"/> KONYA-42	23	12	<input type="checkbox"/> ZONGULDAK-67	0	0

CAPACITY CHOSEN
 Number of vehicle: 4
 Capacity: 55
 Cost by km.: 1
 Fixed Cost: 1
 Insert Delete

4	75	1	1
4	55	1	1

 Sum Of Vehicle: 8
 Total Vehicle Capacity: 520

COMPUTATION COEFFICIENT
 GAMMA: 0.3
 LAMBDA: 0.3
 Number of loops: 40320

ROUTE INFORMATION
 DEPOT: 06
 TOTAL DELIVERY DEMAND: 414
 TOTAL PICK-UP DEMAND: 338
 COMPUTATION

Fig. 7. Decision Support System Input Interface

While “computation” button is used, if the depot is not chosen a warning message as given in Figure 8.

When calculation is finished, an interface, where routes are shown on an output interface, where details of the route is given in Figure 9. Routes, vehicle types used in route, total distance, total cost and amount of picked up and delivered load are given in output interface.



Fig. 8. Warning when depot is not chosen

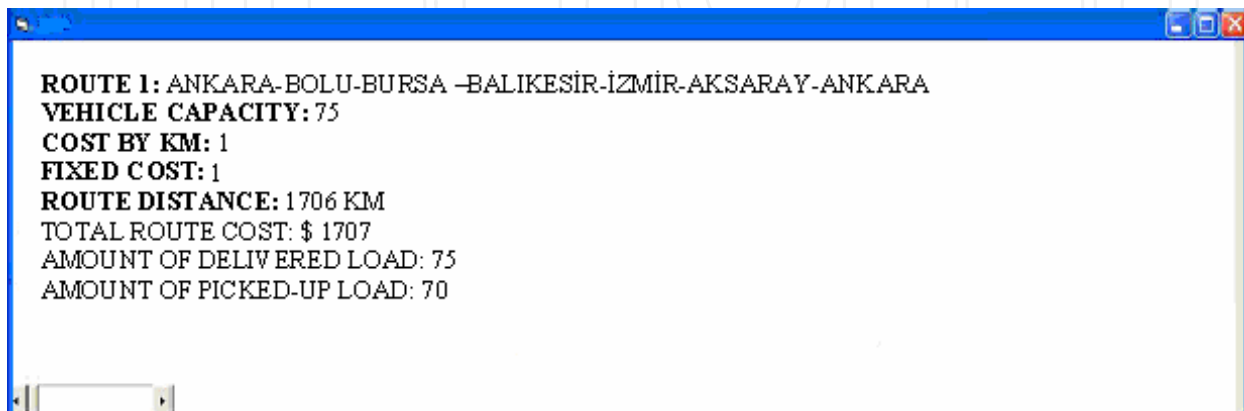

Fig. 9. Output Interface

5. Conclusion

Model-oriented DSS was proposed for the solution of homogeneous and heterogeneous fleet VRPSPD encountered in real life situations.

DSS is a system which enables better understanding of the data about the decision; gives support to decision-maker in establishing more effective decision options and determining the alternatives and; increases the possibility of making the right decision. Mainly DSS constitutes a scientific environment which the decision maker uses and analyzes as he wants and which gives the opportunity to make the decision in a more informed way about the conditions requiring decision making.

VRPSPD are the problems in which delivery and pick-up demands of customers are covered simultaneously along the route. So the customers are visited only for once. VRPSPD are applied in real life in cargo firms; delivery of milk/soda/coke/beer and the empty bottle pick up; delivery and pick up of the personnel to stations in the firms working on shift basis; domestic or local medication delivery and the expired medication pick up; goods delivery and defective or recycle supply pick up from factories to main dealer or from main dealer to small dealers; and sending the required blood from blood centers to hospitals and transferring the donated blood to blood centers. As understood from the application fields, VRPSPD is used in both service and production systems.

The components need to be known are the order of the delivery and pick up points (by considering the extent of vehicle capacity), where delivery and pick up process is carried out; the number of the vehicle characteristics to be used; their intersected distance; and related costs. In the places where the identified duties are performed regularly, delivery and pick up activities might show repetition from the monthly-weekly-daily or within day

aspect. A decision maker system would be required to perform these repetitive procedures in a fast, effective and a scientific way. DSS might be helpful to cover the requirement of a decision maker. Therefore; the solution of VRPSPD could be used for DSS.

6. References

- Ai, T. & Kachitvichyanukul, V. (2009). A particle swarm optimization for the vehicle routing problem with simultaneous pickup and delivery. *Computers & Operations Research*, 36, 1693-1702
- Bianchessi, N. & Righini, G. (2007). Heuristic algorithms for the vehicle routing problem with simultaneous pick-up and delivery. *Computers & Operations Research*, 34, 578-594
- Chen, JF. & Wu, TH. (2006). Vehicle routing problem with simultaneous deliveries and pickups. *The Journal of the Operational Research Society*, 57, 5, 579-587
- Choi, E. & Tcha, DW. (2007). A column generation approach to the heterogeneous fleet vehicle routing problem. *Computers & Operations Research*, 34, 2080-2095
- Dantzig, G.B. & Ramser, J.H. (1959). The truck dispatching problem, *Management Science*, 6-80
- Dethloff, J. (2001). Vehicle routing and reverse logistics: the vehicle routing problem with simultaneous delivery and pick-up. *OR Spectrum*, 23, 79-96
- Gajpal, Y. & Abad, P. (2009). An ant colony system (ACS) for vehicle routing problem with simultaneous delivery and pick up. *Computers & Operations Research*, 36, 3215-3223
- Gencer, C. & Yaşa, Ö. (2007). Simultaneous pick-up and delivery decision support systems of transportation command shuttle tour's. *Journal of the Faculty of Engineering an Architecture of Gazi University*, 22(3), 437-450
- Min, H. (1989). The multiple vehicle routing problem with simultaneous delivery and pick up points. *Transportation Research A*, 23,5, 377-386
- Nagy, G. & Salhi, S. (2005). Heuristic algorithms for single and multiple depot vehicle routing problems with pickups and deliveries. *European journal of operational research*, 162, 1, 126-141
- Özkütük E. (2008). A heuristic algorithm for solving the heterogeneous fleet vehicle routing problem with simultaneous delivery and pick up and decision support system with an application, Master Thesis, Turkish Military Academy Defence Science Institute
- Power, D. J. (1998). Web-based Decision Support Systems. *DSstar, The On-Line Executive Journal for Data-Intensive Decision Support*, 2, 33-34.
- Power, D. J. (2001) Supporting Decision-Makers: An Expanded Framework, In *Harriger, A. (Editor), e-Proceedings Informing Science Conference*, Krakow, Poland, June 19-22, 431-436.
- Power, D. J. (2002) *Decision Support Systems: Concepts and Resources for Managers*, Westport, CT: Greenwood/Quorum
- Taillard, E.D. (1996). A heuristic column generation method for the heterogeneous fleet VRP, *Publication CRT*, 3, 1-13
- Tang Montane F.A. & Galvao R.D. (2006). A tabu search algorithm for the vehicle routing problem with simultaneous pick up and delivery service, *Computers & Operations Research*, 33, 595-619
- Toth, P. & Vigo, D. (2002). *The Vehicle Routing Problem*. SIAM

- Zachariadis, E.E; Tarantilis, C.D. & Kiranoudis, C. T. (2009). An adaptive memory and methodology for the vehicle routing problem with simultaneous pick-ups and deliveries, *European Journal Of Operational Research*
- Zachariadis, E.E.; Tarantilis, C.D. & Kiranoudis, C. T. (2009). A hybrid metaheuristic algorithm for the vehicle routing problem with simultaneous delivery and pick-up service, *Expert System with Applications*, 36, 1070-1081

IntechOpen

IntechOpen



Decision Support Systems Advances in

Edited by Ger Devlin

ISBN 978-953-307-069-8

Hard cover, 342 pages

Publisher InTech

Published online 01, March, 2010

Published in print edition March, 2010

This book by In-Tech publishing helps the reader understand the power of informed decision making by covering a broad range of DSS (Decision Support Systems) applications in the fields of medical, environmental, transport and business. The expertise of the chapter writers spans an equally extensive spectrum of researchers from around the globe including universities in Canada, Mexico, Brazil and the United States, to institutes and universities in Italy, Germany, Poland, France, United Kingdom, Romania, Turkey and Ireland to as far east as Malaysia and Singapore and as far north as Finland. Decision Support Systems are not a new technology but they have evolved and developed with the ever demanding necessity to analyse a large number of options for decision makers (DM) for specific situations, where there is an increasing level of uncertainty about the problem at hand and where there is a high impact relative to the correct decisions to be made. DSS's offer decision makers a more stable solution to solving the semi-structured and unstructured problem. This is exactly what the reader will see in this book.

How to reference

In order to correctly reference this scholarly work, feel free to copy and paste the following:

Cevriye Gencer, Emel Kizilkaya Aydogan and Suna Cetin (2010). Simultaneous Pick-up and Delivery Decision Support Systems, Decision Support Systems Advances in, Ger Devlin (Ed.), ISBN: 978-953-307-069-8, InTech, Available from: <http://www.intechopen.com/books/decision-support-systems-advances-in/simultaneous-pick-up-and-delivery-decision-support-systems>

INTECH
open science | open minds

InTech Europe

University Campus STeP Ri
Slavka Krautzeka 83/A
51000 Rijeka, Croatia
Phone: +385 (51) 770 447
Fax: +385 (51) 686 166
www.intechopen.com

InTech China

Unit 405, Office Block, Hotel Equatorial Shanghai
No.65, Yan An Road (West), Shanghai, 200040, China
中国上海市延安西路65号上海国际贵都大饭店办公楼405单元
Phone: +86-21-62489820
Fax: +86-21-62489821

© 2010 The Author(s). Licensee IntechOpen. This chapter is distributed under the terms of the [Creative Commons Attribution-NonCommercial-ShareAlike-3.0 License](#), which permits use, distribution and reproduction for non-commercial purposes, provided the original is properly cited and derivative works building on this content are distributed under the same license.

IntechOpen

IntechOpen