

We are IntechOpen, the world's leading publisher of Open Access books Built by scientists, for scientists

4,800

Open access books available

122,000

International authors and editors

135M

Downloads

Our authors are among the

154

Countries delivered to

TOP 1%

most cited scientists

12.2%

Contributors from top 500 universities



WEB OF SCIENCE™

Selection of our books indexed in the Book Citation Index
in Web of Science™ Core Collection (BKCI)

Interested in publishing with us?
Contact book.department@intechopen.com

Numbers displayed above are based on latest data collected.

For more information visit www.intechopen.com



A Web-based Decision Support System for Managing Durum Wheat Crops

Vittorio Rossi, Pierluigi Meriggi, Tito Caffi,
Simona Giosué and Tiziano Bettati

*Università Cattolica del Sacro Cuore, Piacenza, Horta Srl, Piacenza,
CRPA, Reggio Emilia,
Italy*

1. Introduction

One important goal in agricultural crop production is to develop less intensive and integrated farming systems with lower inputs of fertilizers and pesticides, and with restricted use of the natural resources (water, soil, energy, etc.). The main objectives of these systems are to maintain crop production in both quantitative and qualitative terms, maintain or preferably improve farm income, and at the same time reduce negative environmental impacts as much as possible. Achieving all of these objectives is a prerequisite for sustainable agriculture (Geng et al., 1990; Jordan & Hutcheon, 1996). Integrated Production (IP) (Boller et al., 2004) and Integrated Farming (IF) (EISA, 2001) have been developed as holistic concepts that involve all crop and farming activities and that shape these activities according to the individual site and farm.

The Thematic Strategy on the Sustainable Use of Pesticides adopted in 2006 by the European Commission aims to establish minimum rules for the use of pesticides in the Community so as to reduce risks to human health and the environment from the use of pesticides. A key component of this Strategy is implementation of Integrated Pest Management (IPM), which will become mandatory as of 2014. In the context of IPM, the EU will develop crop-specific standards, the implementation of which would be voluntary. According to ENDURE (2009), IPM creates synergies by integrating complementary methods drawing from a diverse array of approaches that include biocontrol agents, plant genetics, cultural and mechanical methods, biotechnologies, and information technologies, together with some pesticides that are still needed to control the most problematic pests and to manage critical situations.

Concepts of IPM, IP, and IF are based on dynamic processes and require careful and detailed organisation and management of farm activities at both strategic and tactical levels. This means that time must be invested in management, business planning, data collection and detailed record keeping, and identification of required skills and provision for appropriate training to ensure safe farm operation. In IPM, IP, and IF, farm managers must also know where to obtain expert advice, and they must be willing to accept scientific and technical advances that benefit the environment, food quality, and economic performance, and that therefore can be integrated into the crop management as soon as they are reliable (EISA, 2001).

Source: Decision Support Systems, Advances in, Book edited by: Ger Devlin,
ISBN 978-953-307-069-8, pp. 342, March 2010, INTECH, Croatia, downloaded from SCIYO.COM

Decision Support Systems (DSSs) collect, organize, and integrate all types of information required for producing a crop; DSSs then analyse and interpret the information and finally use the analysis to recommend the most appropriate action or action choices (Agrios, 2005). Expert knowledge, management models, and timely data are key elements of DSS and are used to assist producers with both daily operational and long-range strategic decisions (Sonka et al., 1997). Computer-based DSSs have gained increasing importance since the 1980s, and a large number of DSSs have been developed to assist extension agents, consultants, growers, and other agricultural actors in crop management. Despite their promise, DSSs have contributed little to practical IP in field because of a series of problems (Parker et al., 1997). For example, many simple DSS tools are not widely used because they address only specific problems, whereas agricultural producers must manage a wide range of problems generated by the entire production system. Other obstacles to the practical use of DSSs have been discussed by Magarey et al. (2002).

In this work, a web-based, interactive DSS for holistic crop management of high-quality durum wheat in the Po Valley (North Italy) is described. This interactive DSS incorporates solutions for overcoming possible obstacles for its practical use.

Durum wheat is a case study of particular interest. This crop traditionally accounts for 8% of total EU wheat production; the major producers of durum wheat in the EU are Italy, Spain, France, and Greece, which typically produce about 48, 22, 18, and 10%, respectively, of total EU durum output. Italy and Canada are the main producers worldwide. Durum wheat is traditionally grown in central and southern Italy, but the hectares cropped with durum wheat have recently increased in North Italy. In Emilia-Romagna, for instance, the area has increased by 45% in 2008 (about 67,000 hectares, with a production of about 400,000 tons) compared with 2007 (46,000 hectares) and by more than 100% compared with 2006 (32,000 hectares). This increase is mainly caused by positive trends in the national and international pasta markets; in 2008, the internal consumption of pasta was greater than 1.5 million tons (more than 2.8×10^9 euros), and the export was about 1.6 million tons (about 1.9×10^9 euros) (UNIFI, 2008). Another important factor has been the willingness of the Italian pasta industries to reduce the import of durum wheat. To increase the supply of domestic durum wheat, an important project involving industries, grower associations, and local governments was started for producing high-quality durum wheat in North Italy (Rabboni, 2009). Quality of durum wheat, particularly the protein content and gluten quality, is strictly dependent on cropping choices and cultivation practices, from soil preparation to harvest.

2. Structure of the DSS

The DSS described in this work was designed to overcome most of the obstacles that usually limit DSS use in practical crop management. Magarey et al. (2002) depicted a twenty-first century DSS as a tool that incorporates total management solutions for growers, and they referred to this DSS as the “super consultant”. For durum wheat, the management solutions to be addressed are shown in Figure 1; they include the pre-cultivation strategic choices, the tactical decisions made during the cultivation phase (including harvest), and several post-harvest decisions. Many parts of this “super consultant” have already been developed, but these components need to be integrated to produce a holistic system.

Pre-cultivation and cultivation decisions are important because they cannot be postponed, are often irreversible, represent a substantial allocation of resources, and have a wide range of consequences that impact the farm business for years to come; all of these possible

consequences must be considered by using economic and environmental indicators. These decisions are also difficult because they are complex (they involve many interacting factors and have trade-offs between risk and reward) and/or involve uncertainty (mainly due to the erratic climate) (Clemen, 1990).

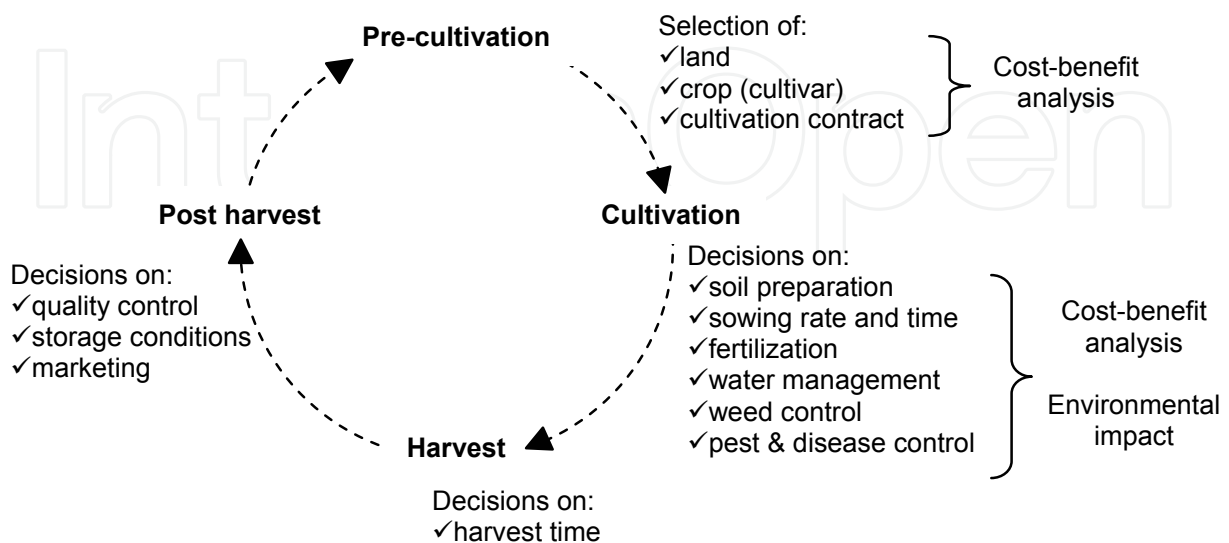

Fig. 1. Main decisions to be made in the production of durum wheat.

The super consultant must be delivered through the World Wide Web (Magarey et al., 2002). A web site eliminates the need for software at the user level and provides a mechanism for a merging of push and pull approaches. Furthermore, it allows the DSS to be updated easily and continuously, so that new knowledge can be provided to farmers even before it is published in research journals (Reddy & Pachepsky, 1997). The super consultant should also have greater automation of interpretation than the current DSS (Magarey et al., 2002). This requires that decision supports are based on static-site profiles and site-specific information; the static-site profile information includes factors about the site that do not change substantially during the growing season (such as previous crop, soil characteristics, cultivar, etc.), while site-specific information may change continuously and must be transmitted directly to the DSS as measurements (such as weather data) or scouting reports (such as the current crop status). Therefore, the DSS for durum wheat was designed to be used in an interactive manner via the Internet.

Lack of clarity about the role of DSSs in decision making, as well as organisational problems related to user support, are among the causes of failure of several DSSs (Rossing & Leeuwis, 1999). DSSs should not be designed or used to replace the decision maker but to help the user make choices by providing additional information; the user remains responsible for the choice and the implementation of actions (Harsh et al., 1989).

Based on the previous considerations, the DSS for durum wheat production was designed following the conceptual diagram of Figure 2. As indicated in this figure, both static-site profiles and site-specific information (data) are viewed as flowing from the environment via instrumented sensors or human activities (scouting, analyses, etc.) to a database. The information is manipulated, analyzed, and interpreted through comparison with available expert knowledge as part of the decision process. The information is processed for producing a decision support. As noted earlier, the decision itself is the responsibility of the

user, and the DSS is not designed to replace the decision maker but to help in making choices by providing additional information. A decision results in an action to be executed within the crop environment. After the action is carried out, the environment is again monitored to begin a new cycle of information flow. Thus, information flows to and from the environment in an endless loop that begins with sensing and ends with action (Sonka et al., 1997).

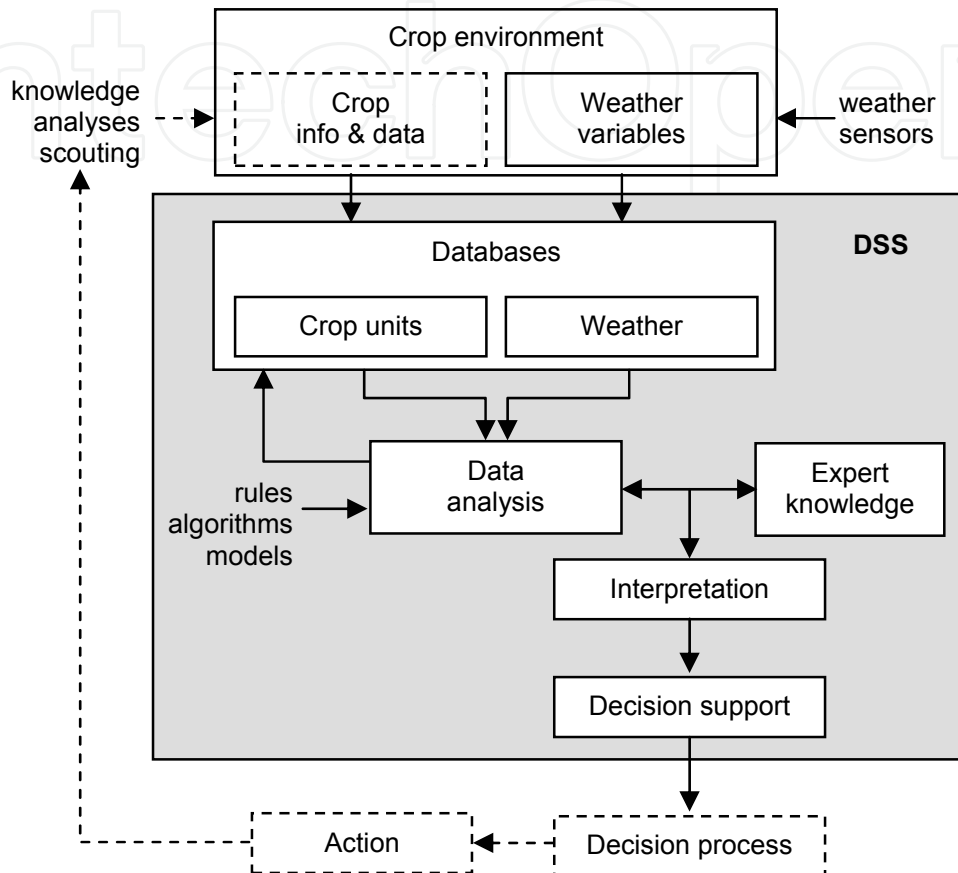

Fig. 2. Conceptual diagram of the DSS for durum wheat cultivation.

2.1 Actors and infrastructures of the DSS

The actors of the DSS and the main infrastructures that they use are shown in Figure 3. The DSS provider is a spin-off company of the University of Piacenza (North Italy), Horta Srl, that manages the process through the web-portal <http://www.horta-srl.com>. The technological infrastructure is managed by CRPA, a company specialized in the use of new information and communication technologies in agriculture. The DSS provider also manages the network of weather stations and of control crops, which provide input data for the DSS. The users of the DSS are the client enterprises (i.e., a single farm, or an organisation that represents many farms, that stipulates an agreement with the provider for accessing the DSS) and the crop manager(s). The crop manager is a person (usually a technician or an advisor) who makes decisions about crop management or suggests the proper actions to the grower. The crop manager directly interacts with the DSS for creating one or more crop units (i.e., a field sown on a uniform piece of land, with the same wheat variety, and cropped in an uniform manner all season long), inputting the crop specific data, and viewing the DSS output. She/he can also interact with the provider for help in interpreting the DSS output.

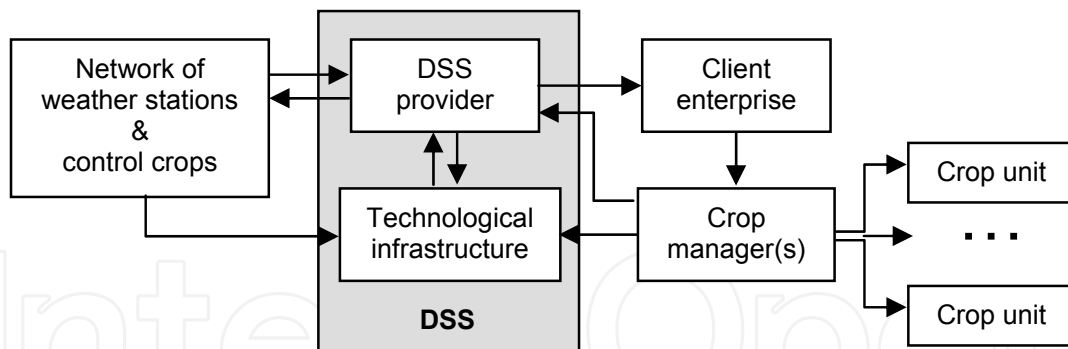

Fig. 3. Actors and infrastructures involved in the DSS for cropping high-quality durum wheat.

2.2 Monitoring the crop environment

A network of weather stations has been created that covers the four climatic areas of the Po Valley (Nanni & Prodi, 2008): i) the Western Po Valley, which includes the flat territory of Turin and Cuneo, characterized by a high rainfall rate and the lowest temperature regime in the Valley ; ii) the Oltrepò Pavese and the district of Alessandria, with similar rainfall as the Western Po Valley but higher temperatures; iii) the Central and Eastern Po Valley, characterized by low winter and high summer rainfall, with the coastal area having higher winter temperatures than the internal territories; and iv) the Friuli plains, which has the highest rainfall in the Valley. Nineteen agro-meteorological stations were installed in selected “representative knots” of each area, based on the surface cropped with durum wheat, as shown in Table 1 and Fig. 4. Additional knots can be included in this network by using agro-meteorological stations belonging to external providers.

Durum wheat-growing areas in North Italy	Hectares cropped with durum wheat (in 2009)	Number of agro-meteorological stations installed
Western Po Valley	1,500	2
Oltrepò Pavese and the district of Alessandria	1,200	1
Central and Eastern Po Valley	87,000	15
Friuli plains	300	1

Table 1. Distribution of the agro-meteorological stations in durum wheat-growing areas of the Po Valley (North Italy).

The agro-meteorological stations (Davis Instruments Corp., Hayward, California) measure air temperature (°C), relative humidity (%), leaf wetness (yes/no), and rainfall (mm) at 1.5 m above the soil. Each station is equipped with an autonomous power source, i.e., a 20-W solar panel and a 60-Ah electric battery.

A network of “reference crops” is created near the agro-meteorological stations. These crops are periodically monitored during the wheat-growing season by the DSS provider in order to collect field data on the crop status. This information is used by the DSS provider for ongoing evaluation and for improved interpretation of the DSS output.

Both static-site and site-specific information are needed for running the DSS in commercial crops. Static-site information depicts the profile of each crop unit, the soil characteristics

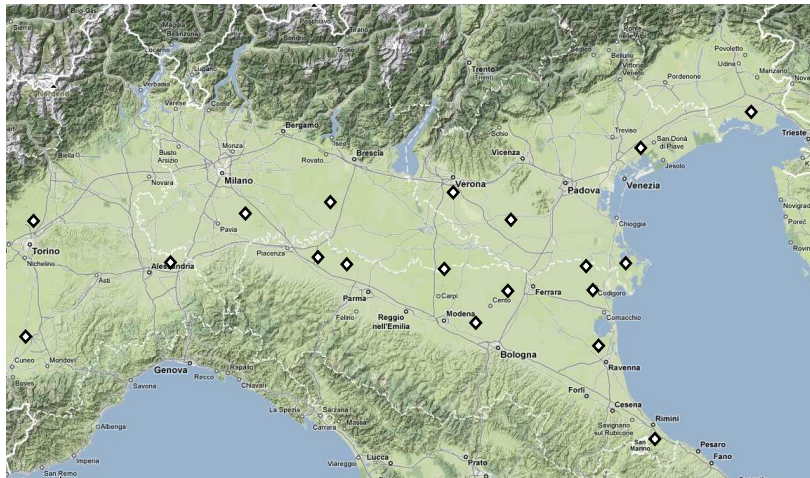

Fig. 4. Geographical distribution of the agro-meteorological stations (diamonds) in the durum wheat-growing areas of the Po Valley (North Italy).

(texture, fertility, organic matter content, etc.) and the contribution of organic fertilization (Tab. 2). Site-specific information is collected during the wheat-growing season by scouting or field observation. This information represents easily collected data describing plant growth, structure of the weed population, and health of the crop.

<u>Identification of the user</u>	<u>Profile of the cropping system</u>
Name of the authorized user	Previous crop
Identification of the crop unit	Soil cultivation methods
Plot surface (ha)	Date of sowing
Geographical coordinates	Yield destination (grains and straw)
Complete address	Variety
<u>Soil texture and fertility</u>	Expected yield (t/ha)
Sand (%)	<u>Organic fertilization</u>
Lime (%)	Regular or occasional
Clay (%)	Frequency of distribution
Organic matter (%)	Concentration of nitrogen (%)
Total (‰) and soluble (ppm) nitrogen	Quantity (t/ha)

Table 2. Main information concerning the static-site profile of each durum wheat crop unit.

2.3 Management of data fluxes

Both weather and crop data are automatically stored in specific databases of the DSS. Each weather station is equipped with a TCP-IP gateway (Netsens Srl, Sesto Fiorentino, Firenze) that sends the data via GPRS/EDGE every 3 to 15 minutes, depending on the weather variable. When weather data are supplied by external providers, an internet-based procedure makes it possible to download the data automatically at fixed time intervals (see section 3.1.1 for further details). As previously mentioned (section 2.2), the crop data are inputted via the Internet into the specific database by the crop manager through an easy-to-use interface of the DSS (see section 3.1.2).

2.4 Data analysis

The weather and crop data are analyzed to produce decision supports for the key aspects of durum wheat cultivation. A step-by-step problem-solving procedure based on important factors relating to the specific process is used for producing decision supports for sowing, nitrogen fertilization, and weed control; decision supports concerning crop growth, pests, and diseases are produced through mathematical models.

The problem-solving process consists of a sequence of sections that fit together; these are: problem definition, problem analysis, generation of possible solutions, analysis of the solutions, and selection of the best solution(s). The process initially involves formally defining the problem to be solved. This first step not only involves formalizing the problem but also ensuring that the correct problem has been identified. The next step in the process is to determine the current situation and what components of the situation have created the problem; a set of criteria by which to evaluate any new solutions are also defined. The next step in problem solving is to generate a number of possible solutions. At this stage, the process generates many solutions but does not evaluate them. In the analysing section of the problem-solving process, the various factors associated with each of the potential solutions are investigated; good and bad points and other factors relevant to each solution are noted but solutions are still not evaluated. In the last step, the various influencing factors for each possible solution are examined and decisions are made about which solutions to keep and which to discard. This selection procedure is frequently iterative; a shortlist of potential solutions is prepared first and then further refined by increasing the depth in the analysis of each solution. Usually the process yields one or a few viable solutions. A good example of this process-solving procedure is provided by Atri et al. (2005) for post-emergence weed management in winter wheat.

Mathematical models are simplified representations of reality (De Wit, 1993). A plant disease model is a simplification of the relationships between a pathogen, a host plant, and the environment that cause an epidemic to develop over time and / or space. Most models used in the DSS for durum wheat have been published (Rossi et al., 1996; Rossi et al., 1997; Rossi & Giosuè, 2003; Rossi et al., 2003a and b; Rossi et al., 2007), and some are extensively used in Italian warning systems for decision making in crop protection at the territorial scale (Bugiani et al., 1993). The disease and plant models used in the DSS were developed following a fundamental approach, where 'fundamental' is the alternative to 'empirical' (Madden & Ellis, 1988). Empirical models describe behaviour of the system on the basis of observations alone and explain nothing of the underlying processes. Fundamental models (also referred to as explanatory, theoretical, or mechanistic models) explain the same behaviour on the basis of what is known about how the system works in relation to the influencing variables (Wainwright & Mulligan, 2004). Fundamental models are also dynamic in that they analyse components of the epidemic and their changes over time due to the external variables influencing them. Dynamic modelling is based on the assumption that the state of the pathosystem in every moment can be quantitatively characterised and that changes in the system can be described with mathematical equations (Rabbinge & De Wit, 1989). The models are also weather-driven, because the weather variables are the main inputs of the model.

The models used in the DSS are tools for simulation and prediction, i.e., they represent a category of models used for extrapolation beyond measured times and spaces (Anderson, 1974; Wainwright & Mulligan, 2004). In this context, prediction is the process of estimation

in unknown past or current situations, which is different from forecasting, the latter term being reserved for extrapolations at future times. Nevertheless, these predictive models can be used as forecasters by using weather forecasts as input factors, or by linking past or current conditions of the epidemic to the future conditions (Campbell & Madden, 1990). For instance, appearance of new disease lesions on the plant depends on infection that occurred some time before and on plant tissue colonisation during the incubation period; infection depends, in turn, on the availability of viable propagules, which have been produced on sporulating lesions, released into the air, and deposited on the plant surface. Therefore, forecasting significant stages of epidemics, like outbreak or increase in intensity, consists of identifying previous significant events and the relationship between past and future events based on the factors influencing both the occurrence of events and their dimension (De Vallavieille-Pope et al., 2000)

2.5 Decision supports

The DSS produces several kinds of output, at different scales of complexity. The DSS provider can access the results with the highest level of detail because the provider must have a complete understanding of the biological process that underlie the production of the decision support. The provider constantly compares this output with the real situation observed in the reference crops (see section 2.2). This kind of output is not shown herein.

The crop manager accesses the output concerning the crop unit(s) she/he has created. Two kinds of output are available for each crop unit. The first output is a "dashboard" with images that summarize current weather conditions, crop growth, and disease risk for a selected station (Fig. 5); in this dashboard, the other functionalities (fertilisation, weed control, etc.) are displayed by icons (not shown). The manager can also click on the image of any disease and observe the level of risk of the selected station in comparison with that of the other stations (Fig. 6).

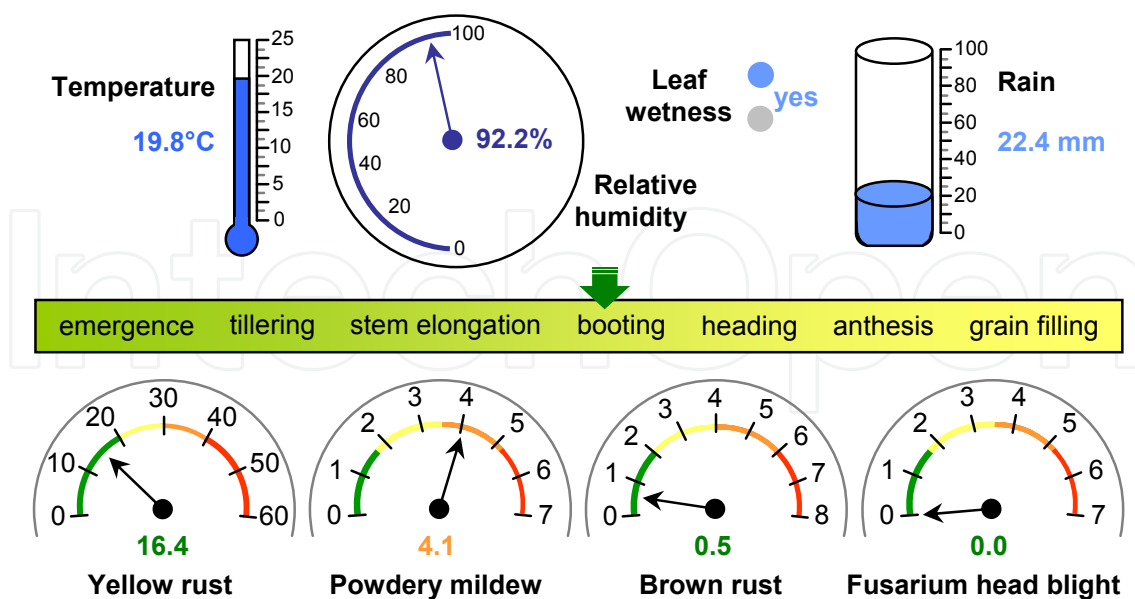

Fig. 5. Example of the dashboard showing current temperature, relative humidity, leaf wetness, and rain; the calculated crop growth stage (green arrow); and level of disease risk (from low in green to very high in red) for yellow rust, powdery mildew, brown rust, and *Fusarium* head blight.



Fig. 6. Example of the map that makes it possible to compare the level of disease risk of a selected agro-meteorological station with that of other stations. The risk ranges from low (green, not present in this figure) to very high (red); the white marker indicates an agro-meteorological station that has not send the data necessary for running the disease models and calculating the level of risk.

The second, more detailed output is accessible by clicking on either images or icons of the dashboard. Some examples of these decision supports are shown in section 4. This approach is similar to the lite- and full-expert system depicted by Magarey et al. (2002): when the lite-expert system detects a potential problem or risk, the user may choose to run the full-expert system to receive more information and a larger choice of recommendations.

3. Technological infrastructure

3.1 DSS design

The technological infrastructure of the DSS comprises the four interrelated components shown in Fig. 7: Weather, Crop, Analyze, and Access.

3.1.1 The “Weather” component

The “Weather” component manages the collection and storage of the weather data as well as the procedures for the quality control of these data. This component consists of the five sub-components shown in Fig. 8.

The “Weather Sensors” subcomponent manages the network of agro-meteorological stations. Each station is equipped with the 2G/2.5G TCP-IP Gateways module produced by Netsens, a module that permits a permanent connection to a server via GPRS/EDGE with a TCP-IP protocol. The “Data Receiver” subcomponent is the infrastructure that receives the data from the agro-meteorological stations in real time (every 3 to 10 min, depending on the weather variable) through the Gateways module, stores these data in a temporary database, computes the hourly values for the variables of interest, and finally stores them in the “Weather DB”. This software is provided by Netsens. The “Data Loader” subcomponent imports the weather data from external providers to the “Weather DB”. This software, written in Java, periodically accesses via FTP the content of one or more shared folders,

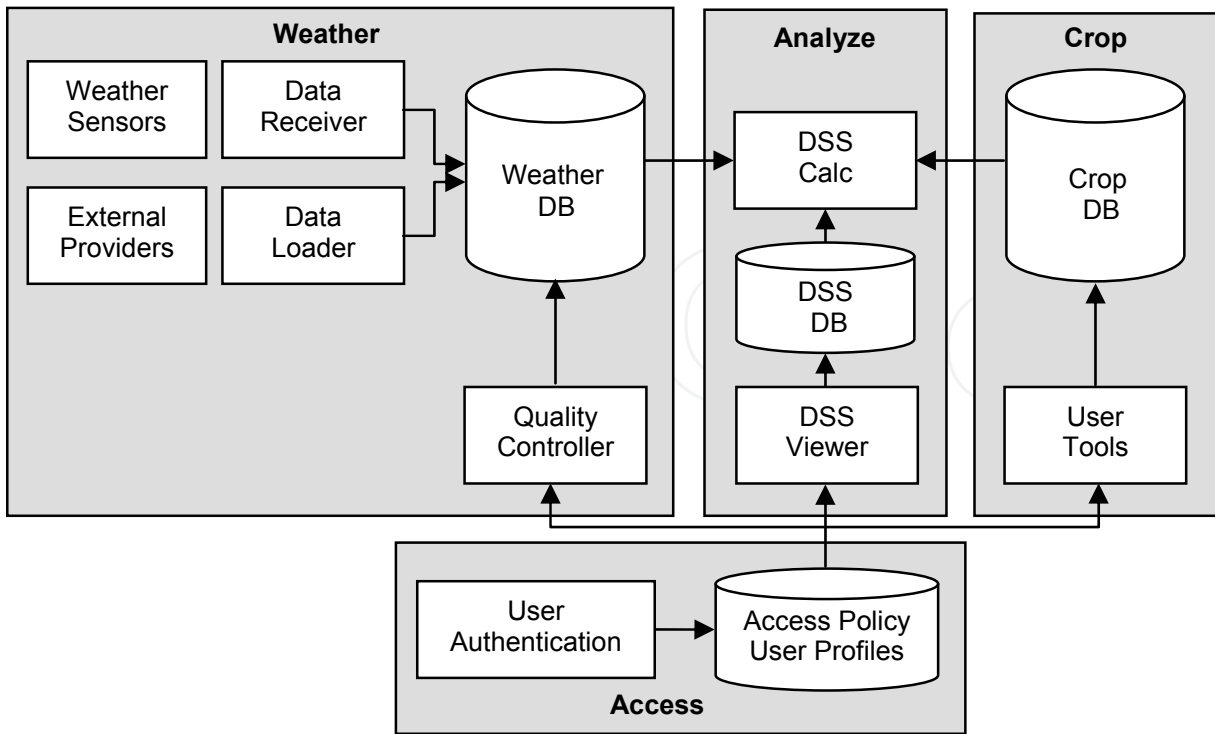

Fig. 7. The four components of the DSS: Weather, Crop, Analyze, and Access.

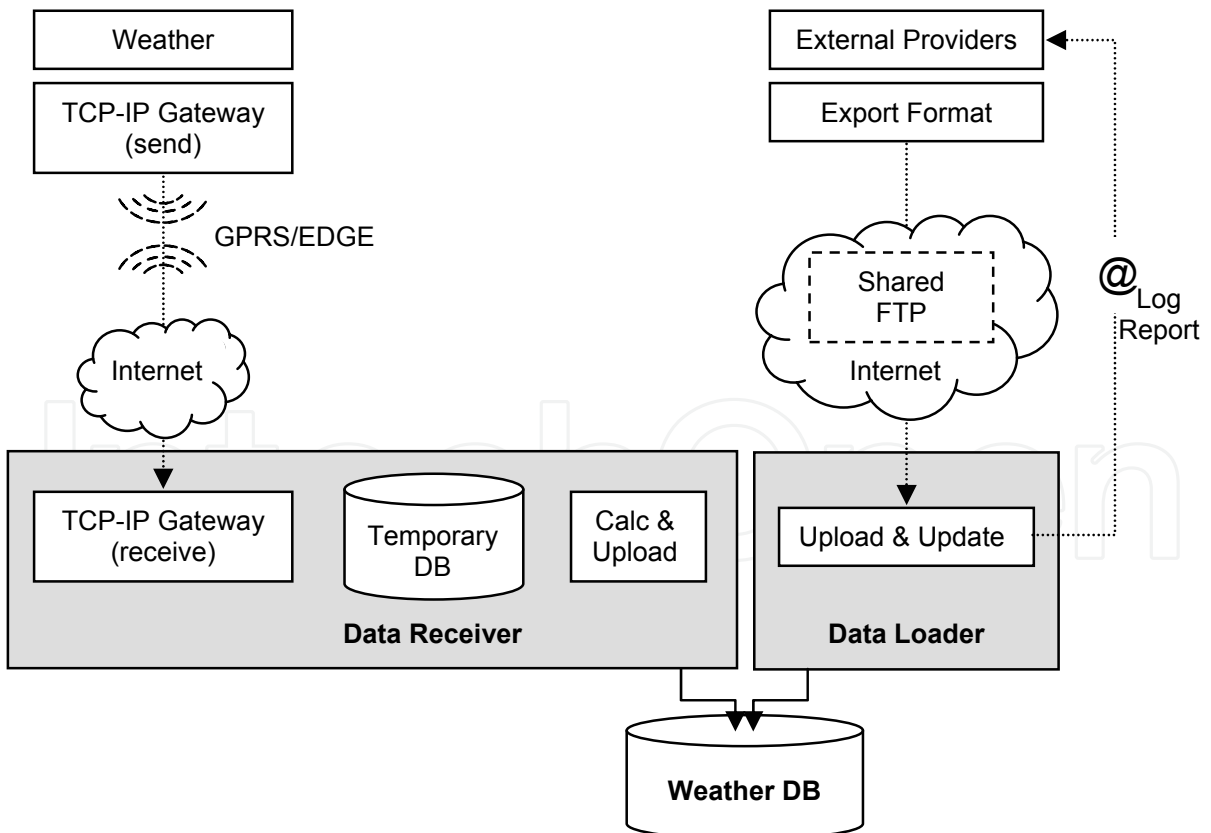

Fig. 8. Procedures concerning management of weather data coming from the network of agro-meteorological stations (on the left) and/or from external data providers (on the right), until the data storage in the Weather database.

scans them for the presence of data, and performs the download on the database. Afterward, the Data Loader produces a file (Log file) with the information concerning the download made, drawing particular attention to possible problems; the Log file is automatically sent by e-mail to the data provider. The “Weather DB” stores the weather data of each knot of the network with both hourly and daily steps; updating occurs asynchronously from the two subcomponents “Data Receiving” and “Data Loader”. The “Quality Controller” subcomponent performs the quality control of the weather data. It consists of some internet services, written in Java, that produce HTML/JavaScript pages that can be accessed by the DSS provider only using an internet browser. The following quality criteria are considered: i) data accuracy (control on data format, comparison with historical ranges, comparison with data from the neighbouring weather stations); ii) completeness of the hourly and daily data series; and iii) working status of the weather stations (Fig. 9).



Fig. 9. Example of the DSS tool showing the real-time working status of the agro-meteorological stations. Green markers indicate a regular flux of data, yellow markers signal a short delay of the station in sending data, while red markers indicate that no data are coming from the station. When the user clicks on the proper marker, the table shows the current data measured by any station selected.

3.1.2 The “Crop” component

The “Crop” component manages administration and storage of the data from the crop units. It has two subcomponents: “User Tools” and “Crop DB”. User Tools are procedures written in Java that, through a series of HTML/JavaScript pages, make it possible to: i) define the user; ii) create crop units; iii) define the agro-meteorological station(s) that represents a crop unit; and iv) insert the specific crop information/data (Fig. 10). The “Crop DB” stores in a database all of the crop unit data mentioned above.

3.1.3 The “Analyze” component

The “Analyze” component contains the procedures for calculating the decision supports (i.e., the main output of the DSS) and for storing them in a database that can be accessed by the users through the “Access” component. The “Analyze” component includes three subcomponents: i) “DSS Calc”, which contains the algorithms that use the inputs for producing the output; ii) “DSS DB”, which stores the results of the calculation procedures (i.e., the output); and iii) “DSS Viewer”, which makes it possible to view the output stored in the “DSS DB” (for those modules that are batch calculated) or to start a new, on-demand calculation of output. The batch-calculated modules are “Crop Growth” and “Diseases”;

Home page	
Calcolo	
Analisi terren	
Calcoli	
Data calcolo :	4-2-2009
Descrizione :	Test 1
N. appezza. :	1
Provincia :	Reggio Emilia
Comune :	Poviglio
Sup. appezzamento (ha) :	10
Zona Vulnerabile :	<input type="checkbox"/>
Utilizza l'analisi :	A 01
Coltura :	Frumento duro (granella)
Varieta' coltura :	LEVANTE
Resa (t/ha) :	7
Coltura anno precedente :	Pomodoro da industria

Fig. 10. Part of the interface of the DSS that the crop manager uses (via the Internet) to insert the specific crop information/data required for producing the decision supports.

they are implemented in Java and, every night, the software reads the input data from the Weather DB and the Crop DB, calculates the output for each crop unit, and stores this output in the DSS DB. The on-demand calculated modules are "Sowing", "Fertilization", "Weeds", and "Fungicides"; they are implemented with query-and-stored procedures that use the data from the Weather DB and the Crop DB. "DSS Viewer" shows in a simple way the key elements that support decision making (see section 2.5).

3.1.4 The "Access" component

The "Access" component includes folders and procedures required for managing the users, connecting to the different modules, and accessing the DSS. This component is supplied by the infrastructure of the web-portal <http://www.agrishare.com>, which makes it possible to manage the different users, including: i) the provider of the DSS, who can access all the information and interact with the whole system; ii) the client enterprise; iii) the crop manager(s); and the crop unit(s) created by each crop manager.

3.2 Hardware and operating systems

The technological infrastructure used for developing the DSS is hosted on three servers, as shown in Table 3 and Figure 11.

4. DSS output

This section discusses examples of the decision supports provided by the DSS for choosing crop rotation, determining the optimum rate of sowing, checking crop growth and development, defining nitrogen fertilization in terms of fertilizer dose and application schedule, defining weed management actions, and making decisions about disease control.

Server	Operating System and DSS components
Oracle Application Server HP ProLiant DL360 G5 (n. 1 CPU)	Linux SUSE SLES 9 SP3 Oracle Application Server 9.0.4.3.0 Enterprise Edition Oracle Internet Directory <ul style="list-style-type: none"> agrishare.com infrastructure
Oracle DBMS Server HP Proliant DL380 G5 (n. 1 CPU)	<ul style="list-style-type: none"> Linux SuSE SLES10 SP1 Oracle DBMS 10.2.0.3.0 Standard Edition
DSS Server Umbrabded hardware (n. 4 six core CPU) Intel Xeon 7400	<ul style="list-style-type: none"> Linux SUSE SLES 10 SP2 x86_64 JBoss 4.2.3 Application Server PostgreSQL 8.3 DBMS NetSens TCP-IP Gateway infrastructure - MySQL and Custom procedures

Table 3. Technological infrastructure of the DDS.

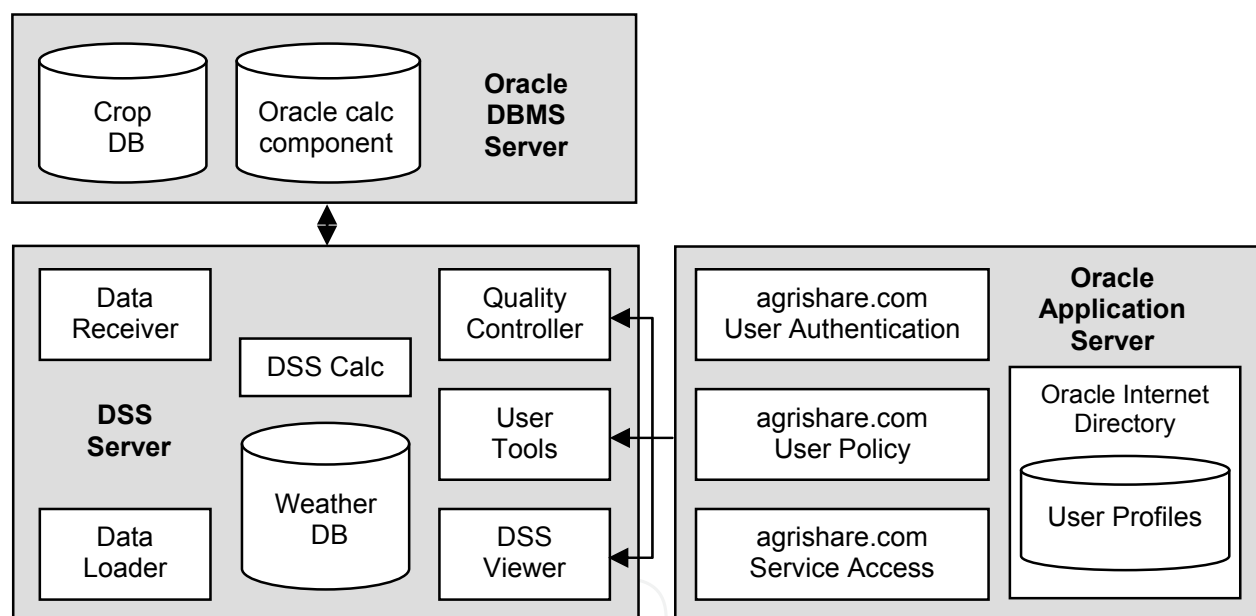

Fig. 11. Server, databases, and software used in the DSS.

4.1 Crop rotation

Crop rotation is a key agronomic practice for the cultivation of durum wheat; rotations of 3 or 4 years are strongly recommended, with at least two to three different crops per rotation. Monoculture or succession with other cereals is discouraged, especially if pathogen inoculum is present in the crop residue.

To help farmers correctly chose crops to be included in rotation with durum wheat, the DSS provides a series of possible crops with indexes of suitability, including economics; the grower can select both crops and indexes of interest, and then look for the crop scores (Fig. 12).

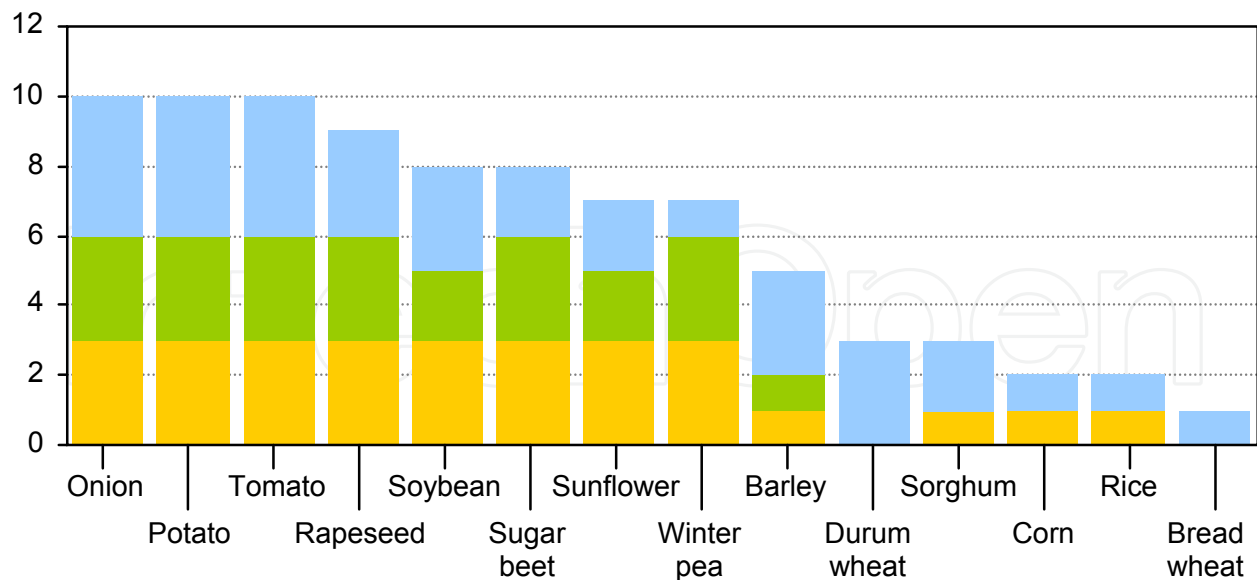

Fig. 12. Example of decision support for selecting crops that precede durum wheat in the rotation, based on residual disease pressure for durum wheat (orange), residual fertility (green), and expected income for the selected crop (blue).

4.2 Sowing

Density of sowing affects the capture of available resources by the crop and strongly influences crop yield and quality. Growth rate is greater when wheat crops are drilled with low plant density than with high plant density, and the same yield is attained because the reduced number of spikes on the low density plant is compensated for by an increased number of kernels per spike (Whaley et al., 2000). Plants grown with low plant density also have greater leaf area, longer leaf area duration, increased radiation use efficiency (because of better distribution of solar radiation through the canopy), and increased canopy nitrogen ratio. As a consequence, kernel size and protein content are greater with low plant density than with high plant density.

Currently, the density of seeds used for durum wheat in northern Italy ranges from 450 to 550 viable seeds per m². In several conditions, these densities are excessive, and there is a risk of reducing the yield quality because of lodging. Optimum seed density depends on cultivar tillering capacity and growth habit, depth and time of sowing, soil aggregation (structure) as a result of soil tillage, and soil moisture (Spink and Blake, 2004).

The DSS takes into account the previously cited variables to determine the ideal population of plants to maximize yield quantity and quality, with particular regard to protein content and kernel size (Fig. 13). The data for calculating the theoretical number of seeds to be sown are: tillering capability of the cultivar, type of soil (in relation to the probable presence of soil aggregates), date of sowing (in relation to seedling emergence and production of tillers), and predicted temperatures after sowing (which affect tillering and which are used as thermal summations, base 5°C, from October to March). Predicted losses of seedlings during emergence are estimated based on seedbed quality, sowing depth, and risk of flooding. All of these data are taken from the Crop and Weather DBs. The DSS provides suggestion on the optimum amount of seed to be used, in kg per hectare.

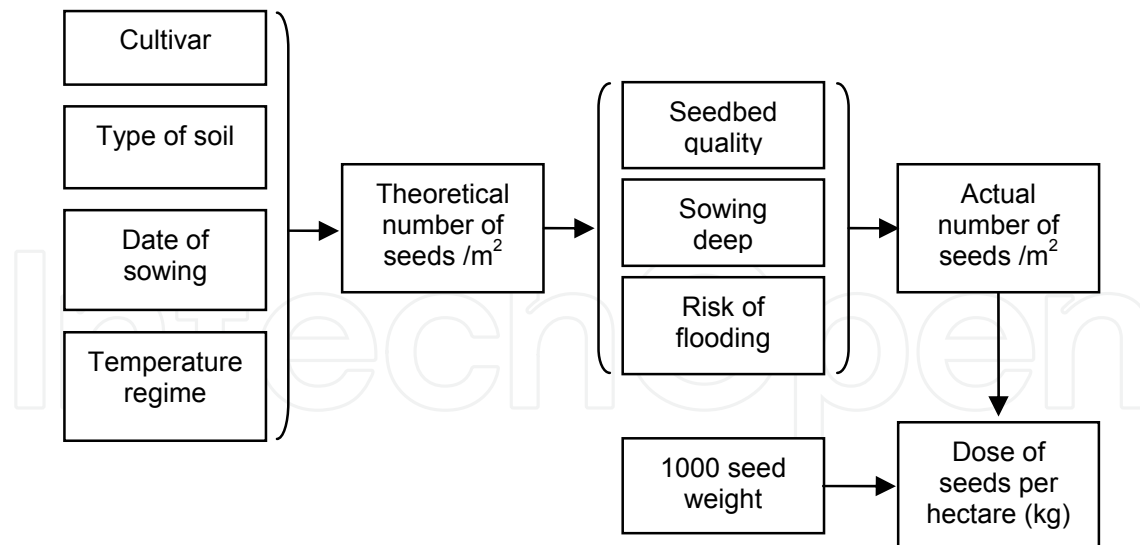

Fig. 13. Flow chart of the step-by-step problem-solving procedure used by the DSS for calculating the optimum seeding rate per hectare.

4.3 Crop growth and development

Crop growth and development is an important variable in decision making because it is relevant to fertilization, weed management, and disease control. Weather and crop-specific data are used as inputs for running a dynamic model that predicts the timing of all key growth stages, leaf-by-leaf development, and tillering.

The basic concepts of the crop model are reported in Rossi et al. (1997). Dynamics of total and green area of each leaf, of spikes, and of stems are calculated from the time of their appearance until complete senescence based on date of sowing, wheat cultivar, and weather variables. An example of the DSS output is provided in Fig. 14.

4.4 Fertilization

Nitrogen fertilization is more complicated and the results are more variable with wheat than with many other field crops. Nitrogen (N) fertilizer is also a significant cost in durum wheat production and can adversely impact both crop and environment when the mineral N leaches out of the crop field and into aquifers. N influences grain yield, grain protein, and grain protein concentration (Toderi & D'Antuono, 2000). Because N is obtained from the soil, plant-available soil N directly influences grain protein yield. The ratio of grain protein yield to total grain yield determines grain protein concentration (percentage of protein); consequently, the influence of N fertilizer on this ratio determines its influence on percentage of grain protein. In general, the higher the yield goal, the more important N management becomes; timing is as important as the amount of N applied (López-Bellido et al., 2006; Meriggi & Bucci, 2007). For instance, N added too early can result in significant losses of N, and when extra N is added as insurance, the potential for lodging and disease increases.

The decision supports provided by the DSS are aimed at fostering economically and environmentally sustainable practices, practices that enable farmers to balance production and environmental goals. The decision supports help the farmer manage N fertilisation so that the N is available when the crop requires the mineral nutrient, and so that the crop takes up all of the N input to prevent the N from leaching into the ground water.

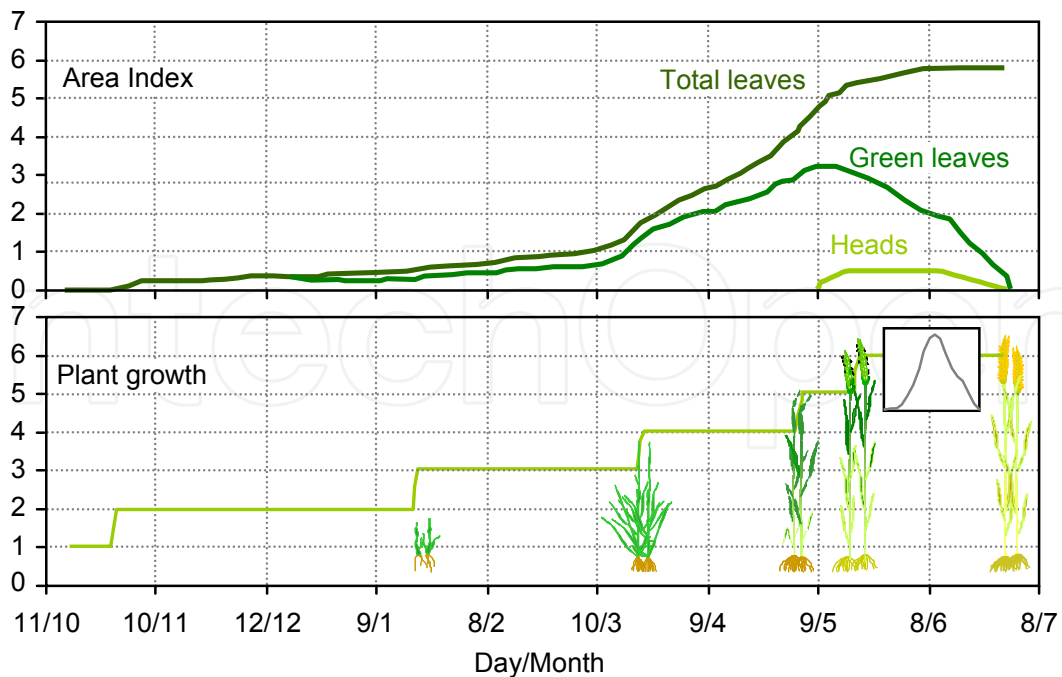

Fig. 14. Dynamics of both green and total LAI (Leaf Area Index), and of HAI (Head Area Index) from sowing to the current day, and relevant growth stages (tillering, stem elongation, booting, anthesis, full ripening). The progress course of anthesis is also shown (small graph) as an important factor influencing decision making for controlling Fusarium head blight. Phases of plant growth are grouped as: 1, sowing to emergence; 2, emergence to tillering; 3, tillering to stem elongation; 4, stem elongation to booting; 5, booting to anthesis; and 6, anthesis to ripening.

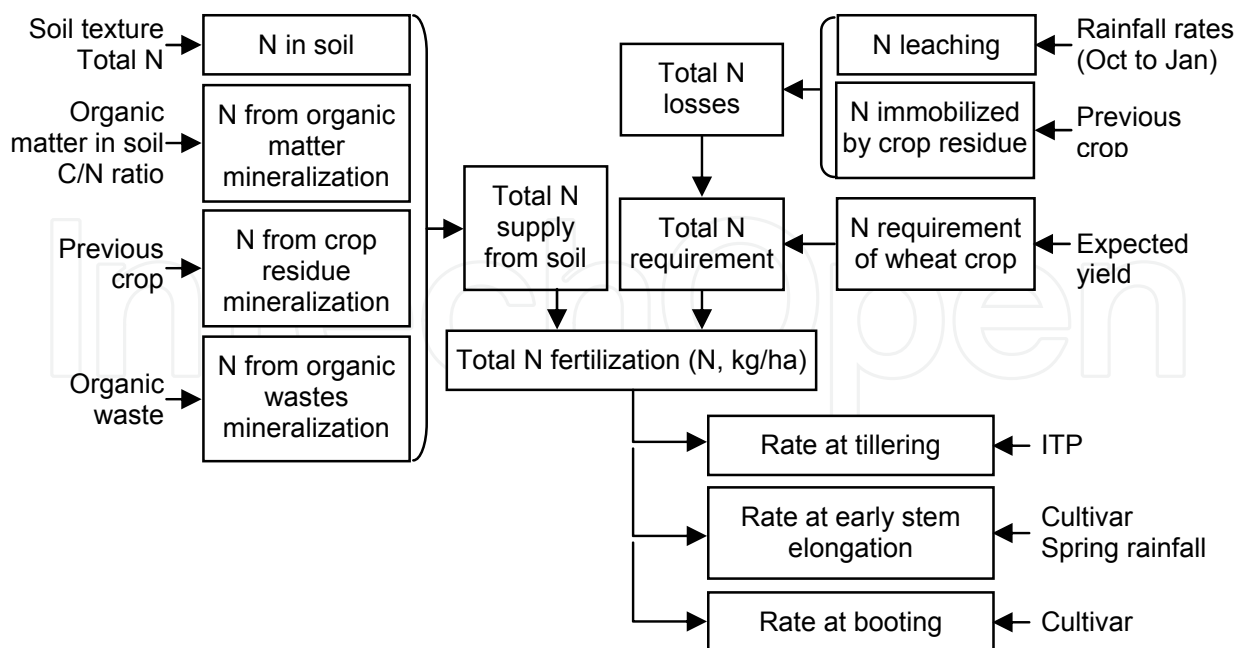

Fig. 15. Flow chart of the procedure used by the DSS for calculating the required level of nitrogen (N) inputs and N application rates in durum wheat; ITP is a specific thermo-pluviometric ratio.

The fertilization tool provides information on the total amount of N fertilizer to be applied for individual crops, as well as options for determining application times and split rates. This tool uses a Nitrogen Simplified Balance Sheet initially developed and calibrated by the Emilia-Romagna Region (www.ermesagricoltura.it) (Fig. 15). All data necessary for calculating the DSS output are stored in the Crop Unit and Weather databases. Quantities of fertiliser inputs (in kg of N per hectare) to be applied depends on N supply and N demand. N supply depends on the natural stock of nitrogen in soil and on the mineralization rate of soil organic matter, previous crop residues, and organic wastes or manures that have been eventually incorporated in soil. N demand depends on the wheat crop demand (which in turn depends on the expected crop yield) and on the N losses due to rainfall in autumn and winter, and on immobilization of N by residue of the previous crop. Splitting of the total N input in different rates depends on crop growth stages (as an estimate of the crop N demand) and weather conditions, i.e., spring rainfall and a specific thermo-pluviometric ratio that accounts for the combined effect of temperature and rain.

4.5 Weed management

Making weed management decisions is often a challenging process. The broad spectrum of weeds present in wheat fields combined with the many herbicides available on the market can make choosing a herbicide or a tank-mixture for a specific field difficult. Selection of a suitable herbicide involves biological traits such as crop characteristics, qualitative and quantitative composition of weed flora, time of weed emergence, relative herbicide efficacy, and weed competitiveness before and after control. The selection also involves economic factors such as grain and herbicide costs, economic damage caused by the weeds, and environmental considerations (Berti et al., 2003).

The DSS aims to achieve economical, environmentally safe, and sustainable weed management. The task is to control weeds with only one herbicide treatment in such a way as to control all the weeds (broadleaves and grasses) at the same time, preferably when they are in earliest growth stages so that herbicide dose is low and competition between weed and crop is minimized.

Variables influencing the decision making process are shown in Fig. 16. Characteristics of the weed population must be defined at the specific-plot level by the crop manager by scouting or on the basis of the previous experience. In the case of scouting, the DSS provides guidelines for identifying weeds and estimating their relative abundance. Soil type and crop growth stage at the current date are available in the specific databases; growth stage of the wheat plant is important for estimating potential yield losses due to weed competition and for selecting selective herbicides. Weather data come from the Weather DB. Some weather variables influence activity and efficacy of both soil-acting and contact-acting herbicides (Bouma, 2008).

The DSS provides advice on the basis of interactions of weeds and wheat and selects the best herbicides with optimum dosage, optimum application time (day and hour of the day, i.e., morning, afternoon, or sunset), and optimum application method. Herbicides are ranked based on both economical and environmental performances. For the economical analysis, herbicides are ranked based on cost, reflecting a balance that includes estimated yield losses due to the weeds, wheat price, expected yield, and herbicide and distribution costs. For the environmental analysis, herbicides are ranked based on dose/treatment index and risk of drift and leaching. Advice is also provided about limitations of the suggested herbicides compared with those of other chemicals.

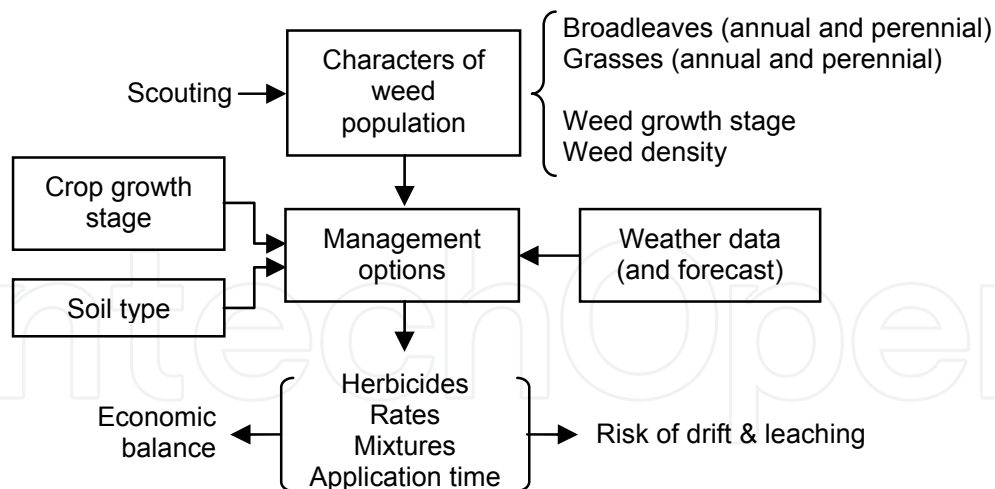

Fig. 16. Flow chart of the procedure used by the DSS for suggesting the best weed management options for each particular field condition.

4.6 Pest and disease control

The following leaf and head diseases are considered in the DSS: powdery mildew, yellow and brown rusts, *Septoria*-disease complex, and *Fusarium* head blight. No insect pests are currently included in the DSS because currently there are no important insect pests of durum wheat in North Italy and generally no insecticides are applied to the crop.

As previously stated, decision supports for managing the indicated fungal diseases were drawn from previously published models. An example is given for *Fusarium* head blight (FHB) and related mycotoxins.

FHB is caused by several *Fusarium* species and is a serious disease of durum wheat in North Italy and in many other areas around the world (Parry et al., 1995); accumulation of mycotoxins in kernels produced by the infected heads is of great concern, and maximum mycotoxin limits have been imposed by EU Commission Regulation (EC) No 856, 6 June 2005. The relational diagram of the FHB-wheat model is shown in Fig. 17 (Rossi et al., 2003a).

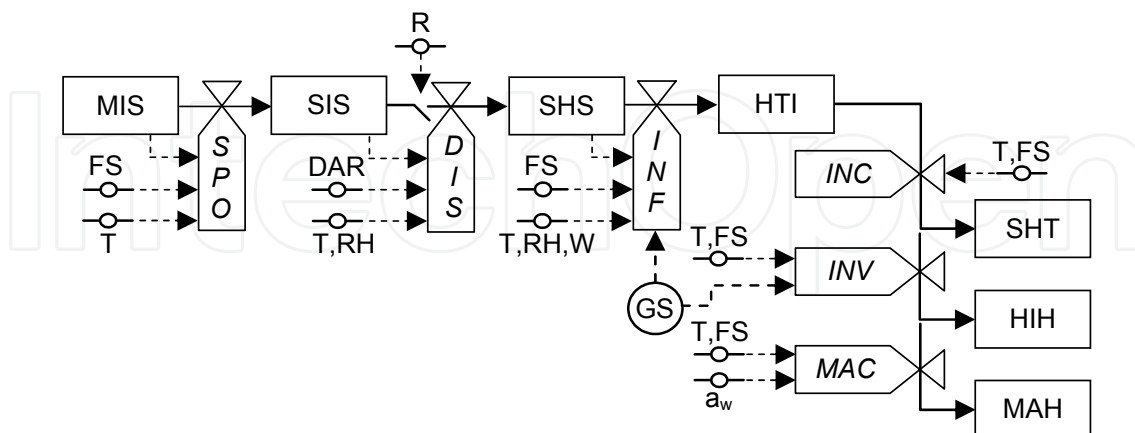

Fig. 17. Diagram of the model for *Fusarium* head blight of wheat and related mycotoxins.

The inoculum source is the fungal mycelium in basal wheat organs or in cereal straw (MIS, Mycelium in Inoculum Sources); the model assumes that MIS is always present for all *Fusarium* species (FS), in equal dose. Inoculum produced on sources (SIS, Spores on Inoculum Sources) depends on a sporulation rate (SPO), while the amount of spores

reaching the head tissues (SHS, Spores on Head Surface) is regulated by a dispersal rate (DIS). An infection rate (INF) accounts for the proportion of the head tissue affected (HTI, Head Tissue Infected). At the end of incubation (INC), FHB symptoms appear on spikes (SHT, Scab on Head Tissue); fungal invasion of head tissues (HIH, Hyphae Invading Head tissue) and mycotoxin production (MAH, Mycotoxin Accumulation on Heads) are regulated by invasion (INV) and mycotoxin accumulation (MAC) rates, respectively. Rates are influenced by air temperature (T), relative humidity (RH), rainfall (R), the number of consecutive days with rain (DAR), wetness duration (W), and free water in the host tissue (a_w). Rates are also influenced by FS and host growth stage (GS). An index for mycotoxin production in affected kernels, named FHB-tox, is calculated daily for two *Fusarium* species, *F. graminearum* and *F. culmorum*, which are the main producers of deoxynivalenol (DON) and zearalenone (ZEN); this index is accumulated over the growing season until harvest. Variables for calculating FHB-tox are SPO, DIS, INF, GS, and INV.

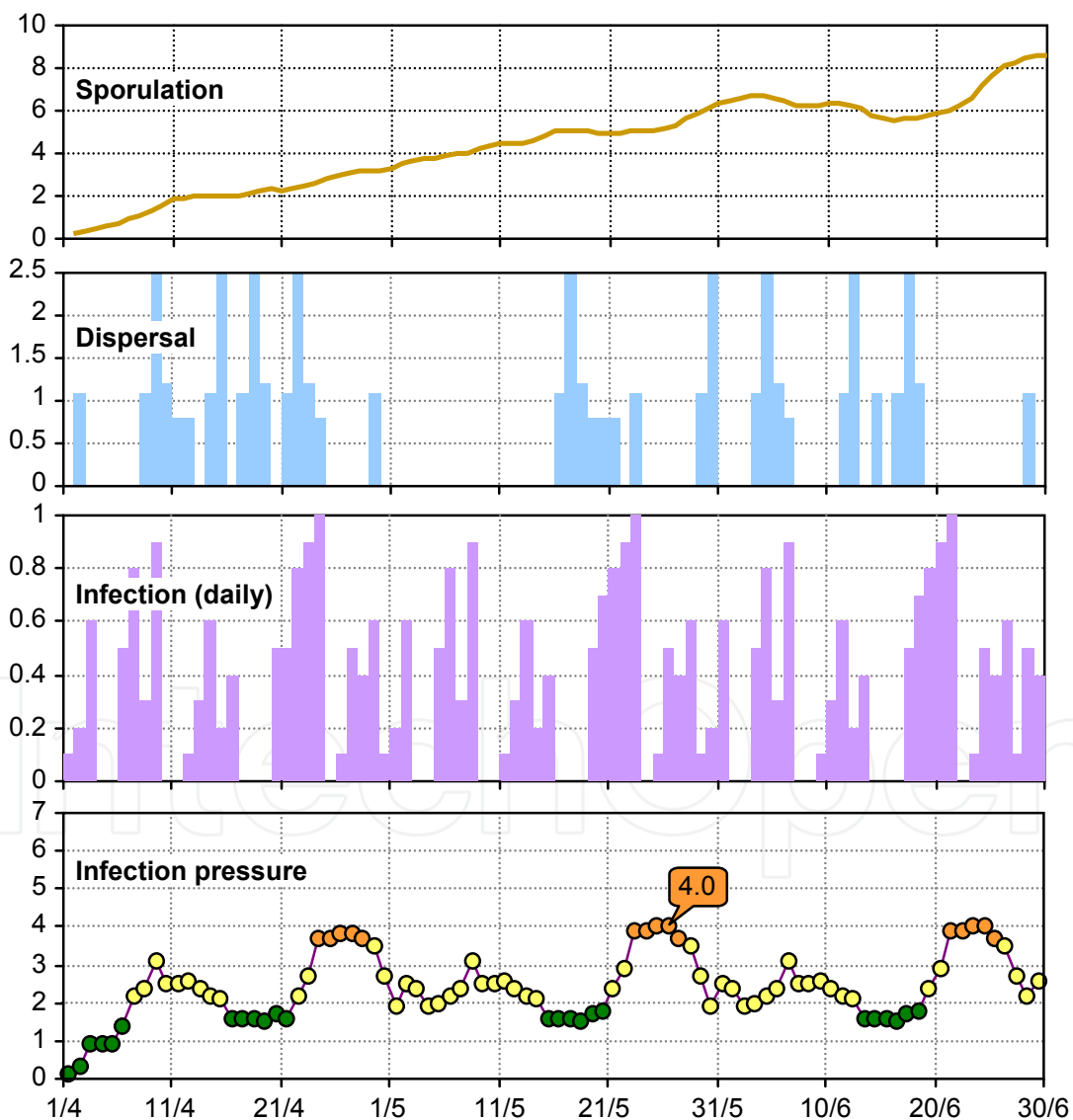

Fig. 18. Example of the decision supports provided by the DSS for managing Fusarium head blight on durum wheat.

The DSS provides four different decision supports (Fig. 18): i) dynamics of pathogen sporulation as a measure of potential pressure of the pathogen; ii) index of spore dispersal as a measure of the inoculum that reaches the heads; iii) daily index of infection as a measure of the proportion of the inoculum able to cause infection of the head tissue; and iv) infection pressure, i.e., the index of infection accumulated over the incubation period of the disease, as a measure of the disease symptoms that will appear in the next days. Four classes of disease risk are defined based on the level of the infection pressure, and specific recommendations are provided for each class (Table 4).

Risk classes	Comments	Recommendations
Low	Environmental conditions are not suitable for disease development.	No specific control actions are necessary to date.
Moderate	Environmental conditions support disease onset in some healthy crops or disease development in the affected crops.	Scout the crop; presence of disease signs requires a thorough evaluation of a possible fungicide application.
High	The disease is likely established in several crops. Environmental conditions are suitable for further disease development.	Probability of disease development is high. If these conditions remain for ≥ 3 consecutive days, scout the crop and, if the disease is present, a fungicide application is recommended. Look up the DSS for risk of other diseases for choosing the best fungicide*.
Very high	The disease is likely established in many crops. Environmental conditions are very suitable for further disease development.	Probability of disease development is very high. Scout the crop and, if the disease is present, a fungicide application is strongly recommended as soon as possible. Look up the DSS for risk of other diseases for choosing the best fungicide*.
* If the crop is subjected to a production disciplinary that regulates the use of fungicides, consult the disciplinary for any constraints on fungicides and maximum number of applications.		

Table 4. Classes of risk for the durum wheat diseases, corresponding comments, and recommendations provided by the DSS.

The DSS also produces a risk index for the contamination of grains by mycotoxins (Rossi et al., 2007). This index is calculated using specific crop information (from the Crop DB) that significantly accounts for the presence of mycotoxins in kernels: weather conditions (X1), cereal growing-area (X2), cereal species (X3), resistance level of the wheat cultivar (X4), previous crop (X5), and kind of soil tillage (X6). Each of these factors has different levels of increasing proneness to FHB (Y1 to Y5). For instance, weather ranges from unfavourable to FHB to very conducive through five increasing levels of proneness defined based on the

FHB-tox calculated by the previously described model (FHB-tox ≤ 10 to FHB-tox > 25). The risk level is calculated by the equation of Table 5. In this equation, X1Yn to X6Yn are the values present in the corresponding cells of Table 5. R ranges between -3.86 and 4.43. The DSS finally defines four levels of increasing risk: low ($R \leq -2$), intermediate ($-2 < R \leq -0.44$), high ($-0.44 < R \leq 1.2$), and very high ($R > 1.2$). For instance, when $R = -2.0$, the probability of mycotoxin-free grains is about 95%; when $R = 2.5$, the probability of high contamination is greater than 85%.

Influencing variables		Groups of increasing proneness to FHB				
		Y1	Y2	Y3	Y4	Y5
Weather	X1	0.921	1.842	2.763	3.684	4.605
Growing area	X2	0.519	1.038	1.557	-	-
Cereal species	X3	0.655	1.310	1.965	-	-
Cultivar	X4	0.342	0.684	1.026	1.368	-
Previous crop	X5	0.272	0.544	0.816	-	-
Soil tillage	X6	0.343	0.686	1.029	-	-
Risk (R) = -6.915 + X1Yn + X2Yn + X3Yn + X4Yn + X5Yn + X6Yn						

Table 5. Coefficients (XnYn) for calculating the level of risk for mycotoxin accumulation in cereal kernels according to equation (R), based on the proneness to Fusarium head blight (FHB) as indicated by different influencing variables.

5. Conclusion

A holistic vision of crop cultivation problems. The DSS for cropping high-quality durum wheat embraces the concept of the integrated approach in designing multidisciplinary decision support systems. This DSS takes into account and provides decision supports for all the key elements of the production chain, from strategic choices to tactical operations. In this way, the DSS should overcome one of the main obstacles to widespread practical use of other DSSs, which is an inadequate consideration of all aspects of production (Parker et al., 1997; Rossing & Leeuwis, 1999; BCPC, 2000; Magarey et al., 2002).

Converting complex decision processes into simple decision supports. DSSs vary in complexity, with production guides at the simple end of the spectrum and a full-expert system at the complex end. Both simple and complex DSSs have disadvantages (Magarey et al., 2002), but farmers generally require clear and concise information. Farmers usually react unfavourably to the delivery of a large amount of redundant information: they need the information to be presented in an attractive, intelligent, and useful form (BCPC, 2000).

The DSS for durum wheat cultivation uses sophisticated technologies and methods for analysing data to produce simple and easy-to-understand decision supports. In that way, the DSS combines the advantages of both simple DSSs (low cost, ease of delivery in multiple ways, and limited time requirements for learning and use of the DSS) and more sophisticated ones (greater integration of knowledge, greater grower choice of management tools and consideration of associated risks). The DSS is then a simple tool that performs a complex task efficiently and effectively.

Furthermore, implementation of the DSS in the World Wide Web should increase its accessibility. A survey by the USDA's National Agricultural Statistics Service found that, in

1999, 40% of US farmers owned or leased computers, although only 29% had access to the Internet; by 2005, these numbers had increased to 55% and 51%, respectively (NASS, 2006). A similar trend is occurring in Europe (EITO, 2001). Today or in the very near future, users will not need to be in their office to access the super consultant: they will communicate with the DSS via personnel data assistants and web-active mobile phones.

Coupling information at territorial and crop scales. In Italy, regional or district scale information products are provided by extension services and, especially, by public services (Rossi et al., 2000). For instance, the PPO (Plant Protection Organisation) of the Emilia-Romagna Region provides public advice, usually on a weekly basis, on the current and forthcoming risks for pests and diseases, and suggestions about the use of pesticides according to the regional IPM guidelines. Growers can freely access this information, usually through the Internet or articles in local newspapers. The DSS for durum wheat does not conflict with this information but enlarges its efficacy by bringing information from the territorial scale to the crop scale. For this reason, several tools used in the DSS for producing decision supports are common to those used by the PPO.

Providing criteria for justifying actions. The trend in agriculture is toward more complex, technologically based crop management, with greater regulation and oversight by both government and processors on the use of chemicals (fertilizers, pesticides, etc.). For example, the Directive on Sustainable Use of Pesticides requires the use of IPM in all the EC Member States by 2014, and asks governments to establish and apply methods for determining whether farmers apply IPM principles in practical crop management. In this context, site-specific data, scouting reports, and recommendations from the DSS will serve as acceptable criteria for justifying (to regulatory authorities, wholesalers, or processors) the application of chemicals.

Perspectives. A preliminary survey showed that the potential users farm about 150,000 hectares. In 2008/09, the DSS was provided free-of-charge to about 30 selected crop managers for validation purposes; similarly, the service will be available with no fees to about 200 crop managers in 2009/10. Later, access to the DSS will be restricted by password to fee-paying users; subscribers will be billed on a per-hectare schedule.

As noted earlier, many DSSs have not been used by farmers. An example is Wheatman, a computerised DSS designed for winter cropping decisions in the northeastern Australian grain belt (Hayman & Easdown, 2002). Use of Wheatman for tactical decision making has been limited by farmer perceptions about the nature of farm management in general and about Wheatman in particular. In contrast to the grain farmers in northeastern Australia, the durum wheat farmers in northern Italy should appreciate the advantages offered by a DSS. Durum wheat farmers in North Italy are accustomed to following guidelines, and they periodically seek advice about crop protection because IPM has been emphasized in this region for about 30 years. In addition, a farm-to-fork project that involves grower associations, milling and pasta industries, and public entities has increased the hectareage cropped with durum wheat, and farmers involved in this project must apply cropping guidelines for producing high quality grains and must document their decisions. As previously mentioned, the Directive on Sustainable Use of Pesticides will stress this procedure starting in 2014. Given this context of farmer and public perceptions and concerns, the widespread use of the DSS seems likely.

6. Acknowledgements

The authors are grateful to CGS Sementi SpA (<http://www.cgssementi.it/>) and Società Produttori Sementi SpA (<http://www.prosementi.com/index.php/ita/>) for helping to fund the development of the “DSS for cropping high-quality durum wheat”.

7. References

- Agrios, G.N. (2005). *Plant pathology* (5^o Ed), Academic Press, ISBN 0120445654, New York
- Anderson, J.R. (1974). Simulation: methodology and application in agricultural economics. *Review of Marketing and Agricultural Economics*, Vol. 42, No. 1, (March 1974) pp. 3-55, ISSN 0034-6616
- Atri, A.; Zand, E.; Baghestani, M.; Khalghani, J. & Partovi, M. (2005). A decision support system for post-emergence weed management in winter wheat, *Proceedings of the 5th conference of the European Federation for Information Technology in Agriculture, 3rd World Congress on Computer in Agriculture and Natural Resources*, pp. 63-66, Vila Real, Portugal, 25-28 July 2005
- BCPC (2000). *The role of decision support systems in the farm business of the future, Discussion Forum*, 9 December 1999, IACR-Rothamsted, Harpenden, Hertfordshire, The British Crop Protection Council, Farnham, Surrey
- Berti, A.; Bravin, F. & Zanin, G. (2003). Application of Decision-Support Software for Postemergence Weed Control. *Weed Science*, Vol. 51, No. 4, (Jul. - Aug. 2003) pp. 618-627, ISSN 0043-1745
- Boller, E.F.; Avilla, J.; Joerg, E.; Malavolta, C.; Wijnands, F.G. & Esbjerg, P. (2004). Guidelines for Integrated Production - Principles and Technical Guidelines. 3rd edition. *IOBC/wprs Bulletin*, Vol. 27, No. 2 (3rd edition), 49 pp, ISBN 92-9067-163-5
- Bouma, E. (2008). *Weather and crop protection*, Roodbont Publishers, ISBN 978-90-8740-002-6, Zutphen, The Netherlands
- Bugiani, R.; Cavanni, P. & Ponti, I. (1993). An advisory service for the occurrence of *Phytophthora infestans* on tomato in Emilia-Romagna Region. *Bulletin OEPP/EPPO*, Vol. 23, No. 4, (December 1993) pp. 607-613, ISSN 0250-8052
- Campbell, C.L. & Madden, L.V. (1990). *Introduction to Plant Disease Epidemiology*, Wiley, ISBN 0-471-83236-7, New York
- Clemen, R.T. (1990). *Making Hard Decisions. An Introduction to Decision Analysis*, PWS-Kent Publishing Co., ISBN 0534260349, Boston, MA
- De Vallavieille-Pope, C.; Giosuè, S.; Munk, L.; Newton, A.C.; Niks, R.E.; Østergård, H.; Pons-Kühnemann, J.; Rossi, V. & Sache, I. (2000). Assessment of epidemiological parameters and their use in epidemiological and forecasting models of cereal airborne diseases. *Agronomie*, Vol. 20, pp. 715-727, ISSN 0249-5627
- De Wit, C.T. (1993). Philosophy and terminology. In: *On system analysis and simulation of ecological processes*, Leffelaar P.A. (ed), Kluwer Academic Publishers, Dordrecht

- EISA (2001). A Common Codex for Integrated Farming. European Initiative for Sustainable Development in Agriculture, <http://www.fao.org/prods/PP17501/EISA.htm>
- EITO (2001). European Information Technology Observatory 2001, Frankfurt European Information Technology Observatory (EITO)
- ENDURE (2009). ENDURE's definition of IPM. <http://www.endure-network.eu/>
- Geng, S.; Hess, C.E. & Auburn, J. (1990). Sustainable agricultural systems: Concepts and definition. *Journal of Agronomy and Crop Science*, Vol. 165, No. 2, (March 1990) pp. 73-85, ISSN 0931-2250
- Harsh, S.B.; Loyd, J.W. & Borton, L.R. (1989). Models as an aid to decision making. *Acta Horticulturae*, Vol. 248, (September 1989) pp. 27-48, ISSN 0567-7572
- Hayman, P.T. & Easdown, W.J. (2002). An ecology of a DSS: reflections on managing wheat crops in the northeastern Australian grains region with WHEATMAN. *Agricultural Systems*, Vol. 74, No. 1, (October 2002) pp. 57-77, ISSN 0308-521X
- Jordan, V.W.L., & Hutcheon, J.A. (1996). Multifunctional crop rotation: the contributions and interactions for integrated crop protection and nutrient management in sustainable cropping systems. *Aspects of Applied Biology*, Vol. 47, pp. 301-308, ISSN 0265-1491
- López-Bellido, L.; López-Bellido, R.J. & López-Bellido, F.J. (2006). Fertilizer Nitrogen Efficiency in Durum Wheat under Rainfed Mediterranean Conditions: Effect of Split Application. *Agronomy Journal*, Vol. 98, pp. 55-62
- Madden, L.V. & Ellis, M.A. (1988). How to develop plant disease forecasters, In: *Experimental Techniques in Plant Disease Epidemiology*, Kranz J., Rotem J. (Eds), pp. 191-208, Springer-Verlag, ISBN 3-540-18128-8, New York
- Magarey, R.D.; Travis, J.W.; Russo, J.M.; Seem, R.C. & Magarey, P.A. (2002). Decision Support Systems: Quenching the Thirst. *Plant Disease*, Vol. 86, No. 1, (January 2002) pp. 4-14, ISSN 0191-2917
- Meriggi, P. & Bucci, V. (2007). Campagna 2008: indicazioni per la concimazione azotata del grano tenero e duro. *Agronomica*, Vol. 6, pp. 4-6
- Nanni, T. & Prodi, F. (2008). Cambiamenti climatici: la situazione in Italia. *Energia*, Vol. 29, No. 1, pp. 66-71
- NASS (2006). Farm computer usage and ownership in 2005. National Agricultural Statistics Service, United States Department of Agriculture, www.nass.usda.gov/nh/2006/FarmComputerUse.pdf
- Parker, C.G.; Campion, S. & Kure H. (1997). Improving the uptake of decision support systems in agriculture, In: Thysen I. & Kristensen A.R. (Eds.), *Proceedings of the First European Conference for Information Technology in Agriculture*, Copenhagen, Denmark, 15-18 June 1997, pp. 129-134, Copenhagen: EFITA, The Royal Veterinary and Agricultural University
- Parry, D.W.; Jenkinson, P. & McLeod, L. (1995). *Fusarium* ear blight (scab) in small grain cereals – a review. *Plant Pathology*, Vol. 44, No. 2, pp. 207-238, ISSN 0032-0862
- Rabbinge, R. & de Wit, C.T. (1989). Systems, models and simulation, In: *Simulation and systems management in crop protection*, Rabbinge R., Ward S.A., van Laar H.H. (Eds.), pp. 3-15, Pudoc, Wageningen, The Netherlands

- Rabboni, T. (2009). Rinnovato l'Accordo di filiera Grano duro di alta qualità. *Filiera Grano Duro News*, Vol. 10, No. 1
- Reddy, V.R. & Pachepsky, Y.A. (1997). Input Optimization and Crop Management Using Decision-support System GLYCIM/GUICS, In: *Proceedings of the International Congress on Modeling and Simulation*, A. David McDonald and Michael McAleer (Eds.), Vol. 3, pp. 1143-1147
- Rossi, V.; Racca, P.; Pancaldi, D. & Alberti, I. (1996). Appearance of *Puccinia recondita* f. sp. *tritici* on winter wheat: a simulation model. *EPPO Bulletin*, Vol. 26, No. 3-4, (September 1996) pp. 555-566, ISSN 0250-8052
- Rossi, V.; Racca, P.; Giosuè, S.; Pancaldi, D. & Alberti, I. (1997). A simulation model for the development of brown rust epidemics in winter wheat. *European Journal of Plant Pathology*, Vol. 103, No. 5, (July 1997) pp. 453-465, ISSN 0929-1873
- Rossi, V.; Ponti, I. & Cravedi, P. (2000). The status of warning services for plant pests in Italy. *EPPO Bulletin*, Vol. 30, No. 1, (March 2000) pp. 19-29, ISSN 0250-8052
- Rossi, V. & Giosuè, S. (2003). A dynamic simulation model for powdery mildew epidemics on winter wheat. *EPPO Bulletin*, Vol. 33, No. 3, (December 2003) pp. 389-396, ISSN 0250-8052
- Rossi, V.; Giosuè, S. & Delogu, G. (2003a). A model estimating risk for Fusarium mycotoxins in wheat kernels. *Aspects of Applied Biology*, Vol. 68, pp. 229-234, ISSN 0265-1491
- Rossi, V.; Giosuè, S.; Patteri, E.; Spanna, F. & Del Vecchio, A. (2003b). A model estimating the risk of Fusarium head blight on wheat. *EPPO Bulletin*, Vol. 33, No. 3, (December 2003) pp. 421-425, ISSN 0250-8052
- Rossi, V.; Giosuè, S.; Terzi, V. & Scudellari, D. (2007). A decision support system for Fusarium head blight on small grain cereals. *EPPO Bulletin*, Vol. 37, No. 2, (August 2007) pp. 359-367, ISSN 0250-8052
- Rossing, W.H.A. & Leeuwis, C. (1999). Quality of modelling for Integrated Crop Management: Introduction to the workshop, *Proceedings of the 5th International Symposium on Computer Modelling in Fruit Research and Orchard Management*, Wageningen, The Netherlands, 28-31 July 1998, *IOBC/WPRS Bulletin*, Vol. 22, No. 6, *Acta Horticulturae*, pp. 147-150
- Sonka, S.T.; Bauer, M.E. & Cherry, E.T. (1997). *Precision Agriculture in the 21st Century: Geospatial and Information Technologies in Crop Management*, National Academy Press, Washington, D.C.
- Spink, J.H. & Blake, J.J. (2004). Can seed rate decisions be improved by improved prediction of establishment? HGCA conference 2004: Managing soil and roots for profitable production. 10.1 - 10.14
- Toderi, G. & D'Antuono, L.F. (2000). Frumento. In: *Coltivazioni erbacee - Cereali e proteaginose*, Baldoni R. & Giardini L. (Eds.), pp. 33-108, Patron Editore, Bologna
- UNIFI (2008). Andamento del settore delle paste alimentari. Unione Industriali Pastai Italiani, <http://www.unifi-pasta.it/dati/andam.htm>
- Wainwright, J. & Mulligan, M. (2004). *Environmental modelling Finding simplicity in complexity*, John Wiley & Sons Ltd, ISBN 0-1-49618-9, Chichester

Whaley, J.M.; Sparkes, D.L.; Foulkes, M.J.; Spink, J.H.; Semere, T. & Scott, R.K. (2000).
The physiological response of winter wheat to reductions in plant density.
Annals of Applied Biology, Vol. 137, No. 2, (1 October 2000) pp.165-177, ISSN 0003-
4746

IntechOpen

IntechOpen



Decision Support Systems Advances in

Edited by Ger Devlin

ISBN 978-953-307-069-8

Hard cover, 342 pages

Publisher InTech

Published online 01, March, 2010

Published in print edition March, 2010

This book by In-Tech publishing helps the reader understand the power of informed decision making by covering a broad range of DSS (Decision Support Systems) applications in the fields of medical, environmental, transport and business. The expertise of the chapter writers spans an equally extensive spectrum of researchers from around the globe including universities in Canada, Mexico, Brazil and the United States, to institutes and universities in Italy, Germany, Poland, France, United Kingdom, Romania, Turkey and Ireland to as far east as Malaysia and Singapore and as far north as Finland. Decision Support Systems are not a new technology but they have evolved and developed with the ever demanding necessity to analyse a large number of options for decision makers (DM) for specific situations, where there is an increasing level of uncertainty about the problem at hand and where there is a high impact relative to the correct decisions to be made. DSS's offer decision makers a more stable solution to solving the semi-structured and unstructured problem. This is exactly what the reader will see in this book.

How to reference

In order to correctly reference this scholarly work, feel free to copy and paste the following:

Vittorio Rossi, Pierluigi Meriggi, Tito Caffi, Simona Giosue and Tiziano Bettati (2010). A Web-based Decision Support System for Managing Durum Wheat Crops, Decision Support Systems Advances in, Ger Devlin (Ed.), ISBN: 978-953-307-069-8, InTech, Available from: <http://www.intechopen.com/books/decision-support-systems-advances-in/a-web-based-decision-support-system-for-managing-durum-wheat-crops>

INTECH
open science | open minds

InTech Europe

University Campus STeP Ri
Slavka Krautzeka 83/A
51000 Rijeka, Croatia
Phone: +385 (51) 770 447
Fax: +385 (51) 686 166
www.intechopen.com

InTech China

Unit 405, Office Block, Hotel Equatorial Shanghai
No.65, Yan An Road (West), Shanghai, 200040, China
中国上海市延安西路65号上海国际贵都大饭店办公楼405单元
Phone: +86-21-62489820
Fax: +86-21-62489821

© 2010 The Author(s). Licensee IntechOpen. This chapter is distributed under the terms of the [Creative Commons Attribution-NonCommercial-ShareAlike-3.0 License](#), which permits use, distribution and reproduction for non-commercial purposes, provided the original is properly cited and derivative works building on this content are distributed under the same license.

IntechOpen

IntechOpen