

# We are IntechOpen, the world's leading publisher of Open Access books Built by scientists, for scientists

**4,800**

Open access books available

**122,000**

International authors and editors

**135M**

Downloads

Our authors are among the

**154**

Countries delivered to

**TOP 1%**

most cited scientists

**12.2%**

Contributors from top 500 universities



**WEB OF SCIENCE™**

Selection of our books indexed in the Book Citation Index  
in Web of Science™ Core Collection (BKCI)

Interested in publishing with us?  
Contact [book.department@intechopen.com](mailto:book.department@intechopen.com)

Numbers displayed above are based on latest data collected.

For more information visit [www.intechopen.com](http://www.intechopen.com)



# Graphical User Interface for PON Network Management System

Boonchuan Ng, Mohammad Syuhaimi Ab-Rahman and Kasmiran Jumari  
*Universiti Kebangsaan Malaysia (UKM)*  
*Malaysia*

## 1. Introduction

Optical diagnosis, performance monitoring, and characterization are essential for ensuring the high quality operation of any lightwave systems. In fact, an efficient and reliable optical network, such as passive optical network (PON), depends on appropriate testing and measurement. An optical measurement and management system tool named Smart Access Network \_ Testing, Analyzing and Database (SANTAD) is designed and developed as a measurement strategy with improved performance for in-service transmission surveillance applications in PON. Visual Basic is used as programming language in the applications that allow the remote personal computer (PC) to interact with optical time domain reflectometer (OTDR). A microcontroller based system has been developed to be located at middle of the network system for handling the centralized line detection from central office (CO). The hardware system responsible in diverting the 1625 nm OTDR testing signal to bypass the filter and connect to each optical network (ONU). As a result, the lines' status can be observed and monitored at static point where the OTDR injecting the signal. The OTDR is accomplished to remote PC through the 10/100 Ethernet port running using Microsoft Visual Basic 2008 platform. The Ethernet remote interface allowed the users to access the OTDR test module over any Internet-connected PC.

The design and implementation of this integrated hardware/software system enable all the OTDR measurements can be transmitted into PC easily. The key idea is to accumulate all OTDR measurement to be displayed on a PC screen for centralized monitoring and advanced analyzing. SANTAD is focused on providing survivability through event identification against degradation/losses and failures. Any occurrence of fault in the network system can be identified by a drastic drop of optical power level. The failure information will be sent to field engineers through the mobile phone or Wi-Fi/Internet computer using wireless technology for repairing and maintenance operation. The analysis results will then stored in database, all kinds of additional information can be easily accessed and queried later. The lab prototype of SANTAD is implemented in PON and the beneficial and contribution of the proposed approach is highly achieved the Operation, Administration, and Maintenance (OAM) features. The experimental results show the system accurately detects and locates fiber degradations/failures, and alerts the field engineers with the details of failures/faults within 30 seconds. The system database allows the network operators to assess long term network performance. The main advantages of

Source: User Interfaces, Book edited by: Rita Mátrai,  
ISBN 978-953-307-084-1, pp. 270, May 2010, INTECH, Croatia, downloaded from SCIYO.COM

this work is to improve the survivability and efficiency of PON, while reduce the hands on workload as well as maintenance cost and time.

## 2. Passive Optical Network (PON)

PON is one among several architectures that can be used in fiber-to-the-home (FTTH). PON has been early described for FTTH as early as 1986. PON is today the main choice of many network services providers and operators since it breaks through the economic barrier of traditional point-to-point (P2P) solutions. PON provides a powerful point-to-multipoint (P2MP) solution to satisfy the increasing demand in the access part of the communication infrastructures between CO and customers sides (Skubic et al., 2009). The installations as can be seen in Figure 1

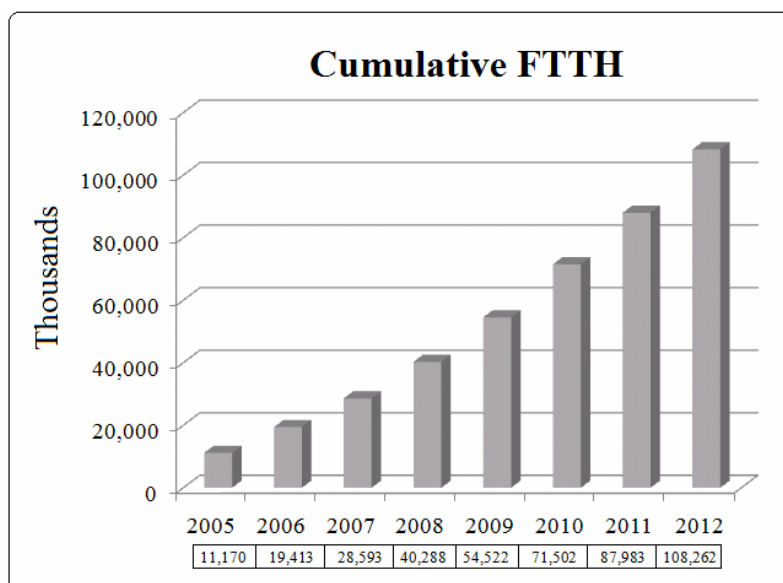

Fig. 1. Cumulative global growth of FTTH for the years 2005-2012

PON is a technology viewed by many as an attractive solution to the first mile problem; a PON minimizes the number of optical transceivers, CO terminations, and fiber deployment. A PON is a P2MP optical network with no active elements in the signal path from source to destination. The only interior elements used in a PON are passive optical components, such as optical fiber, splices, and splitters (see Figure 2). A PON employs a passive device (i.e., optical splitter/branching device, etc, that not requiring any power) to split an optical signal signals from multiple fibers into one. PON is capable of delivering triple-play (data, voice, and voice) services at long reach up to 20 km between CO and customer sides. All transmission in a PON is performed between an optical line terminal (OLT) and ONUs. OLT resides at CO; while ONU is located at the end-user location (Mukherjee, 2006).

Nowadays, PON is commonly deployed as it can offer a cost-efficient and scalable solution to provide huge-capacity optical access (Prat, 2007). The cost effectiveness of PON depends on numbers of ONUs per OLT optical transceiver, the cost of fiber and its installation, the cost of the digital subscriber line (DSL) transceivers at ONU and subscriber premise equipments, the overall cost of powering ONU, and the real estate cost of placing the ONU (Gorshe, 2006). Fixed network and exchange costs are shared among all subscribers. This reduces the key cost per subscriber metric. The PON solution benefits from having no

outside-plant electronic to reduce the network complexity and life-cycle costs, while improving the reliability of FTTH (Corning, 2005).

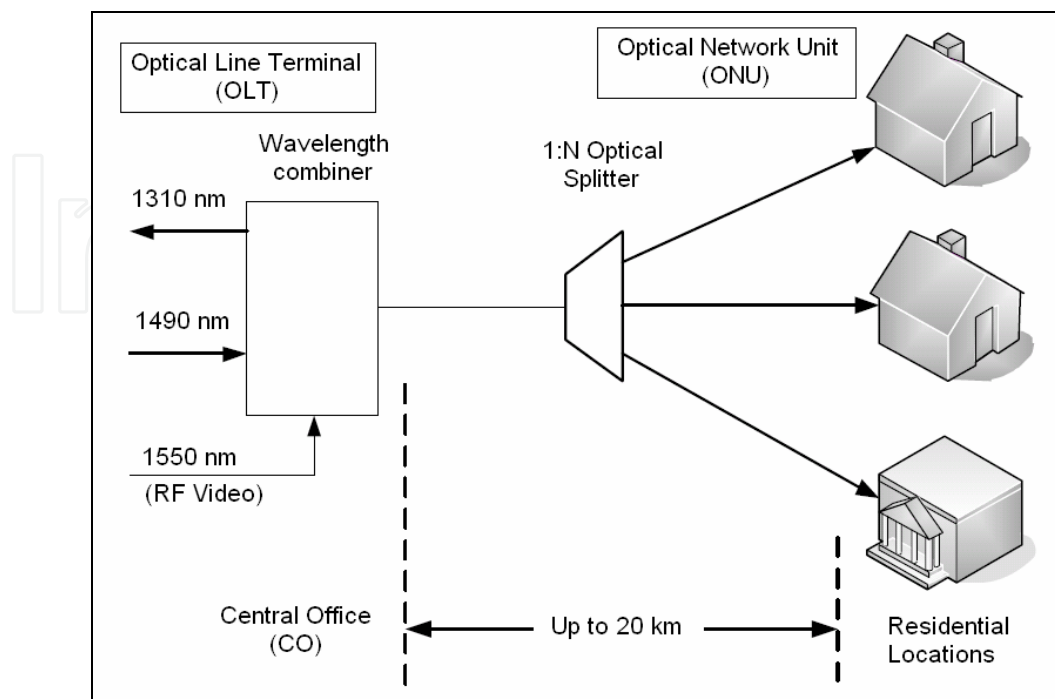

Fig. 2. Conventional PON architecture

### 2.1 Fiber fault in PON

The introduction of PON allows the network to transport huge amounts of data and provide communication services that play a very important role in many of our daily social and economical activities. Network reliability is an issue of deep concern to network operators being eager to deploy high capacity fiber networks, since a single failure in the network could result in significant losses of revenue. The importance of network reliability will keep pace with the steadily increasing network capacity. For very-high-capacity future optical networks, carrying multitudes of 10 Gbps channels per fiber strand, a failure of optical connection will interrupt a vast amount of services running on-line, making the connection availability a factor of great significance (Wosinska et al., 2009).

Communication networks can be subject to both unintentional failures, caused by natural disasters, wear out and overload, software bugs, human errors, etc and intentional interruptions due to maintenance. As core communication networks also play a vital military role, key telecommunication nodes were favored targets during the Gulf War, and could become a likely target for terrorist activity. For business customers, disruption of communication can suspend critical operations, which may cause a significant loss of revenue, to be reclaimed from the telecommunications provider. In fact, availability agreements now form an important component of Service Level Agreements (SLAs) between providers and customers. In the cutthroat world of modern telecommunications, network operators need a reliable and maintainable network in order to hold a leading edge over the competition (Wosinska et al., 2009).

Troubleshooting a PON involves locating and identifying the source of an optical problem in what may be a complex optical network topology that includes several OLT, optical

splitter, fibers, and ONUs. Since most components in the network are passive, a large part of the issues are due to dirty/damaged/misaligned connectors or breaks/macrobends in the optical fiber cables. These will affect one, some or all subscribers on the network, depending on the location of the problem. If a break occurs in the feeder region (from OLT to optical splitter), all downstream signals toward ONUs will be affected. However, if a problem such as macrobending or dirty connector causes optical power to be lost somewhere in the network, only a number of ONUs may be affected. Since the attenuation in optical fiber cables is proportional to length, distant ONUs received a weaker downstream signal than closer ones. The upstream signals received at CO from more distant ONUs are also weaker and the OLT will detect such decreased performance (EXFO 2008).

A network failure due to fiber break in current optical communication systems network could make the network services providers and operators very difficult to restore their system back to normal. They would face major problems locating the faulty cable and the break point along the optical cable. According to the cases reported to the Federal Communication Commission (FCC) in US, more than one-third of service disruptions are due to fiber cable problems. This kind of problem usually take longer time to resolve compared to the transmission equipment failure (Bakar et al., 2007). Since the PON can accommodate a large number of subscribers, when any occurrence of fiber cut/fault, the access network will be breakdown/terminated. Due to the large transport capacity achieved by optical access network, failures caused huge losses of data and greatly influence upon a large number of users over a wide area. Any service outage due to a fiber break can be translated into tremendous financial loss in business for the network service providers (Chan et al., 1999).

## **2.2 PON network monitoring and troubleshooting with OTDR**

Fiber fault within PON becomes more significant due to the increasing demand for reliable service delivery. Several developed test gears are invented to locate a fiber fault in an optical fiber, such as fault locator and OTDR (Bakar et al., 2007). OTDR was first reported in 1976 (Barnoki & Jensen, 1976) as a telecommunications application and became an established technique for attenuation monitoring and fault location in optical fiber network within the telecommunications industry (King et al., 2004). OTDR is an instrument that used to measure parameters such as attenuation, length, connector and splice losses, reflectance level, and locating faults with in an optical link (Keiser 2000). It injects a short, intense laser pulse into optical fiber and measures the backscatter and reflection of light as a function of time. The reflected light characteristics are analyzed to determine the location of any optical fiber fault/break or splice loss. Modern OTDRs can locate and evaluate the losses of fusion splices and connectors and can even report whether each location and loss is within certain specification tolerances (Anderson et al., 2004).

Therefore, in order to facilitate effective and prompt network protection and restoration, it is highly desirable to perform network survivability measures in the optical layer. This can be achieved by simple fiber link or equipment duplication with protection switching or some other intelligent schemes with minimal resource duplication or reservation for protection. For PON applications, equipment failure at either OLT or ONU can be easily remedied by having a backup unit in the controlled environment. However, for any fiber cut, it would take a relatively long time to perform the repair. Therefore, it is highly desirable to have survivable PON architectures with protection switching against any fiber cut survivability (Chan, 2007).

### 3. Smart Access Network \_ Testing, Analyzing and Database (SANTAD)

A real time optical network monitoring and management system tool named SANTAD is developed for monitoring the network performance and managing the PON network system more efficiency. SANTAD is a centralized access control and surveillance system that enables the network operators and field engineers to view traffic flow and detect breakdown as well as other circumstances that may require some appropriate action with the graphical user interface (GUI) processing capabilities of Microsoft Visual Basic 2008 (VB9) programming.

SANTAD combines remote controlling, centralized monitoring and troubleshooting, fault detection, optical switching as well as protection and restoration apparatus to deliver high quality of service (QoS) for PON network system. Microsoft Visual Basic 2008 programming is chosen as software development tool in developing the access control program of this work; while the hardware development is divided into 3 main parts: (i) Network testing and troubleshooting with OTDR, (ii) Interfacing OTDR test module with remote workstation, and (iii) Centralized monitoring and advanced data analyzing.

The system architecture of SANTAD consists of 4 phases, which are optical monitoring, interface and data communication, advanced data analyzing, and failure notification. The system design is very simple, it required a commercially available OTDR, router, and a remote workstation (PC/laptop) with Microsoft Visual Basic 2008 programming. Figure 3 explains briefly the entire work.

The functionalities of SANTAD can be generally classified into pre-configured protection and post-fault restoration, which can assist the network operators and field engineers to perform the following activities in PON network system:

- Events/data recording
- Further processing of controlling/monitoring information for preventive maintenance
- Presentation of surveillance image (visual feedback)
- Provide a control function to intercom all subscribers with CO
- Monitor and control the network performance
- Detect degradations before a fiber fault occurs for preventive maintenance
- Detect any fiber failure/fault/cut that occurs in the network system and troubleshoot it for post-fault maintenance

Performance monitoring and network troubleshooting are important in providing a high efficiency and reliability access network for the subscribers. Therefore, the network operators and field engineers are full-time concern for managing the optical network and devices/equipments. By using SANTAD, the network operators and field engineers are able to keep an eye on their works at all times. This capability drastically reduces the time it takes to identify and analyze the cause of fault as well as the maintenance and repairing time, which leads to customers' satisfaction.

#### 3.1 System design

Due to the U-band (ultra long wavelength band; 1625-1675 nm) light is different from the wide communication band (1260-1600 nm) and has been reserved for standard PON monitoring, the network system can perform in-service testing by using 1625 nm light source with no degradation to the transmission quality and interruption, therefore has no impact on the data traffic. Modern OTDR often offer capabilities in the fourth window region at 1625 nm (EXFO, 2008).

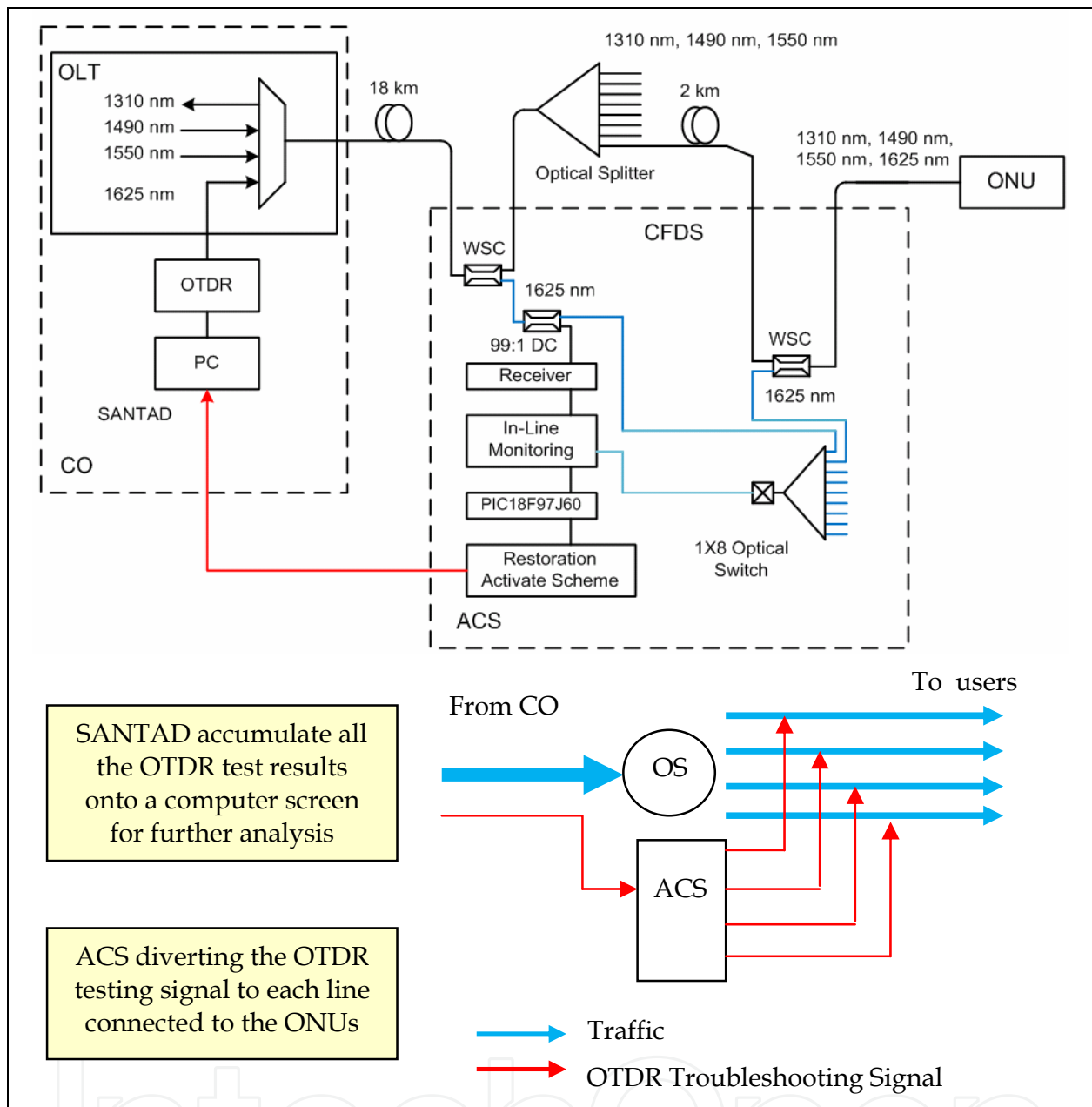

Fig. 3. System architecture of optical network monitoring and management system for PON

As illustrated in Figure 3, the triple-play signals (1310 nm, 1490 nm, and 1550 nm) are multiplexed (combined) with 1625 nm OTDR testing signal. A tapper circuit is designed to allow the OTDR testing signal to bypass the optical splitter in a conventional PON when emitted in downstream direction (from CO towards multiple customer residential locations). When 4 kinds of signals are distributed, the testing signal will be split up by the wavelength selective coupler (WSC), which is installed before the optical splitter. The WSC coupler only allow the 1625 nm signal to enter into the tapper circuit and filter all unwanted signals that contaminate the OTDR measurement. The downstream signal will go through the WSC, which in turn connected to the optical splitter before it reaches the multiple ONUs at different customer residential locations. On the other hand, the 1625 nm signal which is demultiplexed by WSC coupler will be split up again in power ratio 99:1 by using

directional coupler (DC) to activate the microprocessor system. The 99% 1625 nm signal will then be configured by using optical splitter which each output is connected to single line of ONU. The operational of optical switch is controlled by microprocessor system that is activated by 1% of 1625 nm testing signal.

In order to enable wavelength splitting (demultiplexing) and combining (multiplexing) in the tapper circuit, WSC coupler is designed for the optical signals having different light wavelengths can be separated or combined to transmit in single optical fiber as shown in Figure 4. WSC coupler is actually a demultiplexer but with limited to 2 output ports. It is an optical device that functions to split out the signal according to their frequencies but each output arms are not limited only to 1 wavelength as applied in demultiplexer. The WSC coupler is designed on silica substrate with compliance of PON wavelengths. The designed WSC coupler is used as a router for specific wavelength in order to detect any optical line failure in PON application. The triple-play signals enter the waveguide in port 1 and OTDR testing signal enters the waveguide at port 3. The 1625 nm testing signal generated by the OTDR will be used to scan the status of PON. All the wavelengths must flow out through port 2. In reverse mode, the device is applicable to split the 1625 nm testing signal from triple-play signals (Rahman et al., 2008).

There are 2 reasons to setup a tapper circuit to bypass the 1625 nm testing signal from the conventional PON system architecture. First, the WSC only allow the 1625 nm testing signal to enter into the tapper circuit and filter all unwanted signals that contaminate the OTDR measurement. Second is to reduce the large loss of optical splitter, which limits the OTDR's ability to test far after passing the optical splitter. The performance of the device was modeled and simulated using Beam Propagation Method (BPM-Cad). It shows that the insertion loss of each WSC port is 0.0391 dB (Rahman et al., 2008); however the loss of optical splitter 1x8 is 9.0 dB (10%).

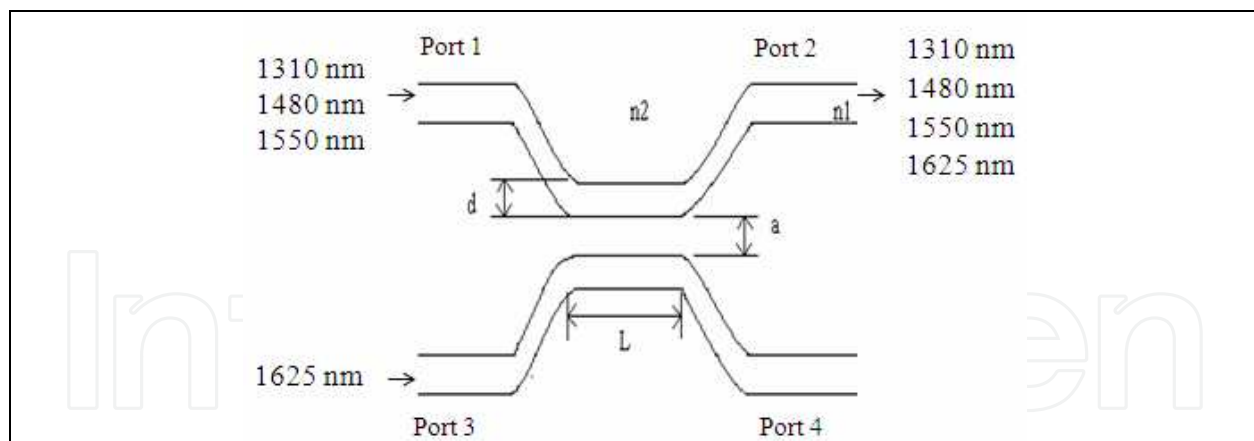

Fig. 4. Structure of WSC coupler which operate the wavelength used in PON application

### 3.2 Principle enhancement of SANTAD

#### 3.2.1 Path monitoring control with Access Control System (ACS)

Access Control System (ACS) has been developed as a supported device in our proposed system. ACS is a functional tool for monitoring, testing, and analyzing as well as activates the protection switch in the restoration process for PON network system as presented in Figure 5. ACS is the core of proposed design. It locates at the middle of the network system for controlling the devices/components in feeder region and drop region and responsible in



routing the OTDR to the specific line to enable them be monitored from CO. It becomes an intelligent control centre that used as an intermediate medium for controlling the monitoring and protection system in the access network. The system architecture of ACS is structured into 2 major parts: (i) Path monitoring control and (ii) Protection and restoration scheme activation. ACS consists of a microcontroller system, 1x8 optical switch, Centralized Failure Troubleshooting System (CFTS), Multi Access Detection System (MADS), Multi Ratio Optical Splitter (MROS), and Smart Restoration Scheme (SRS).

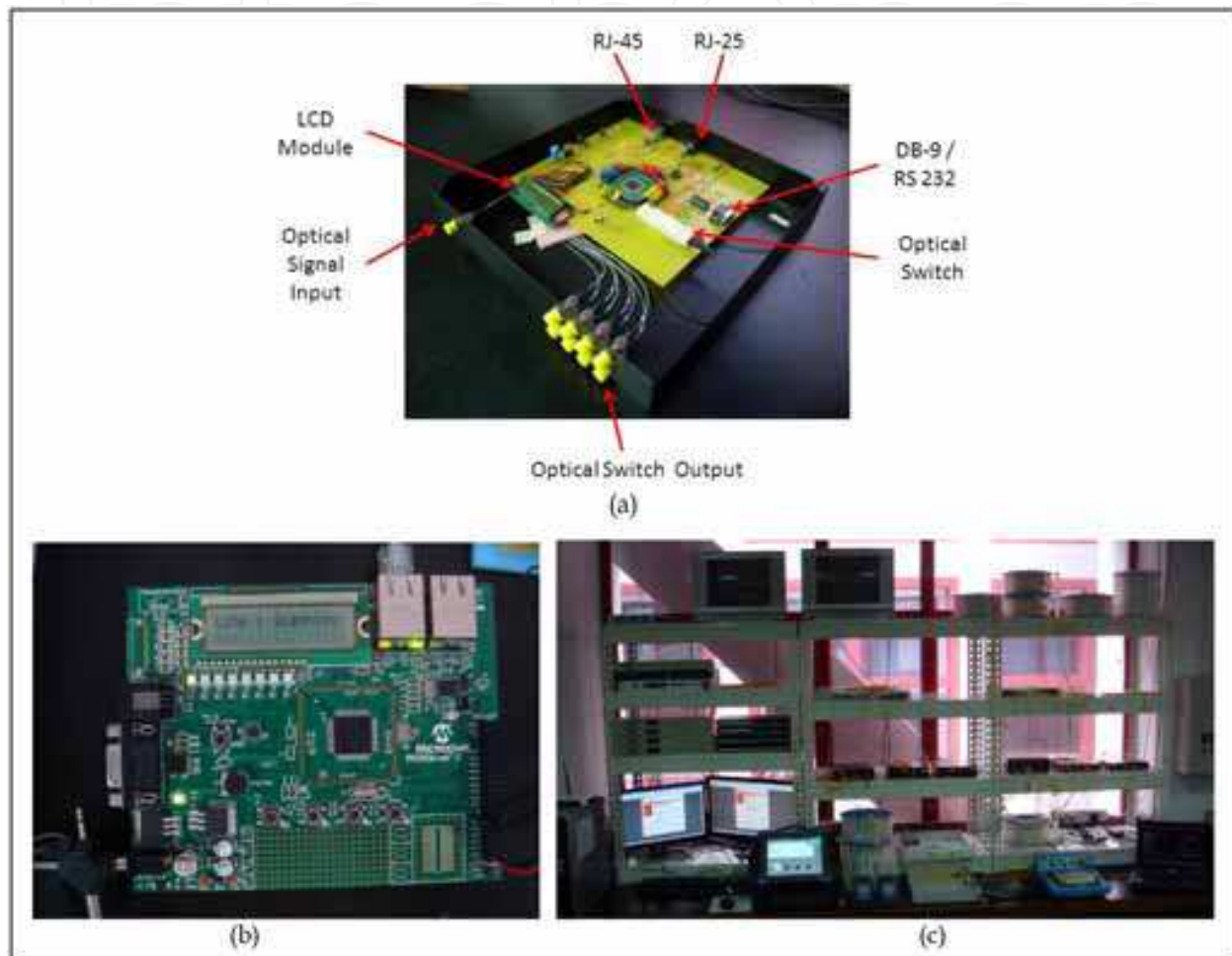

Fig. 5. Access Control System (ACS), (a) Lab prototype, (b) PIC18F97J60 microcontroller and (c) Experimental setup for diverting OTDR testing signal

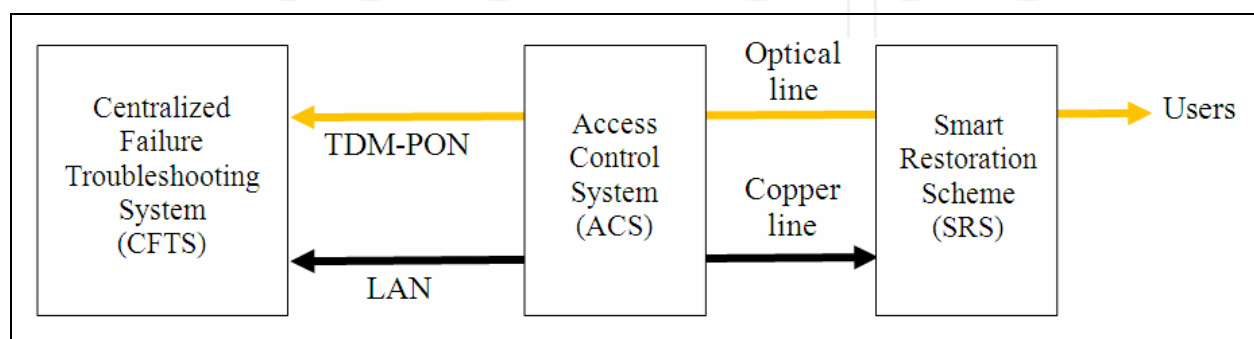

Fig. 6. The integration of PON and ADSL network

In the proposed system design, the optical network system (PON) is collaterally together with conventional asymmetric digital subscriber line (ADSL) network as illustrated in Figure 6. The PON used fiber to carry the information signal; meanwhile the ADSL used metallic wire to carry the control signal. The ADSL used the access control network to activate installed devices/elements in the network system. Also, if the optical network goes down.

CFTS is focusing on path routing for monitoring the network's status and detecting the failure; while MADS is a monitoring system that use to detect any occurrence of fault in the drop region. The ACS will receive signal from CFTS to identify the operation made; either routing the OTDR's signal to a specific line for detection scheme or still continue for the monitoring scheme performed by MADS. The detection scheme through CFTS offers 2 operation modes, (i) Automatic control and (ii) Manual control. Automatic control routes the OTDR's signal periodically line by line. Meanwhile, the manual control will use the code send by the network operator to route the signal to a specific line.

ACS controls the status of any optical switch device that connected to it and transmits its status to the PIC18F97J60 microcontroller. Its then arranges the information in the form of a packet and transmits it over the local access network (LAN) using embedded Ethernet system. ACS is equipped with state-of-the art fiber fault identification equipment to detecting the cause of any failure.

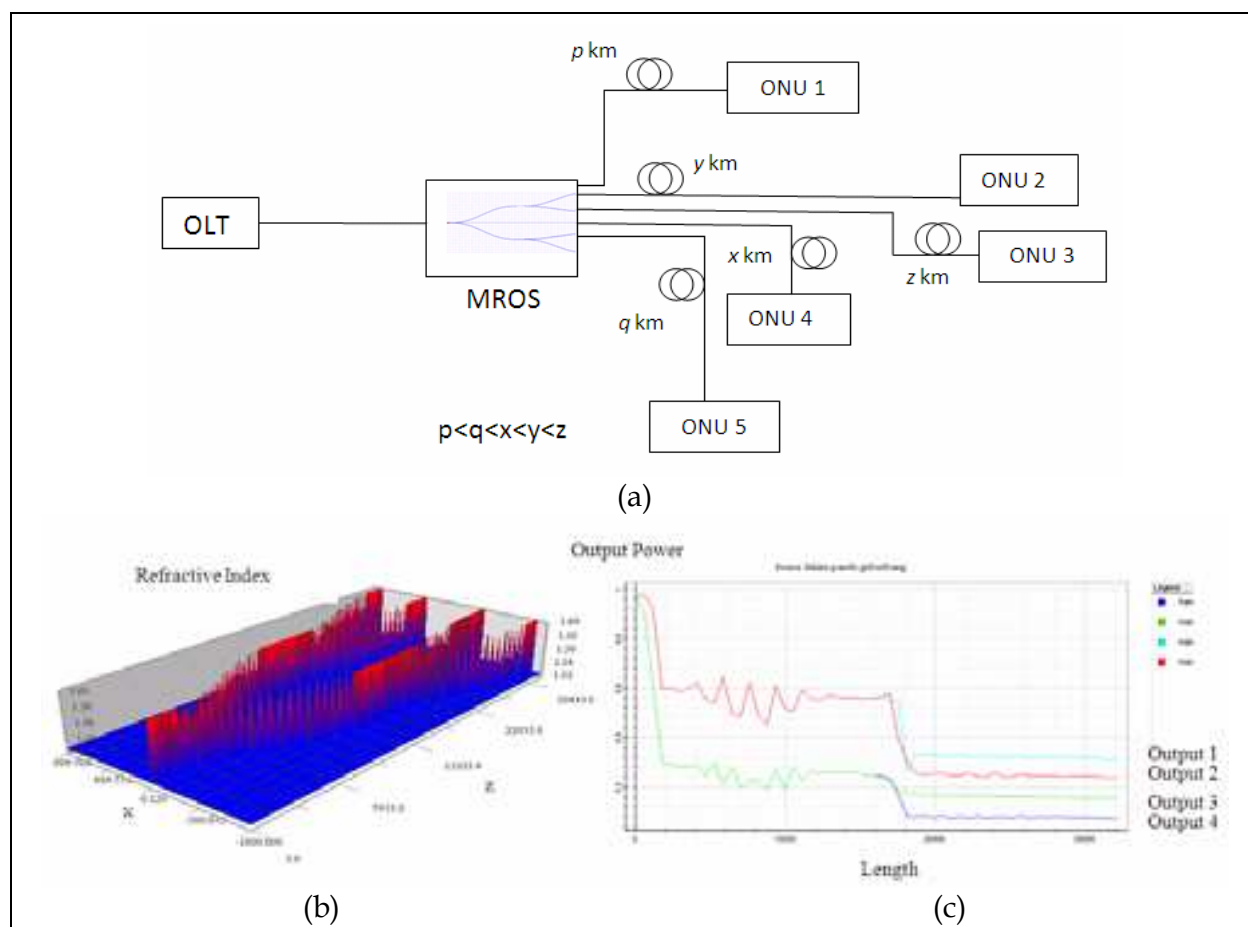

Fig. 7. (a) The MROS as a component in ACS is located at the center of PON to optimize the signal power distribution to each number of users enable the distance can be extended more than 20 km from the OLT, (b) The signal propagates in 1x4 MROS, and (c) The characteristic of optimized output power associated with the device length.

Tapping 3% of the downstream and upstream signal by using coupler, ACS can recognize the status of feeder section and drop section. If breakdown occurs in feeder section, ACS will send a signal to activate the dedicated protection scheme. But if the breakdown is detected in drop section, ACS will recognize the related access line by the 3% tapped signal that is connected to every access line. The activation signal is then sent to active the dedicated protection scheme. But if fault is still not restored, the shared protection scheme will be activated. The monitoring signal section is responsible for sensing fault and its location whereas generation of activation of signal is sent by activation section in ACS.

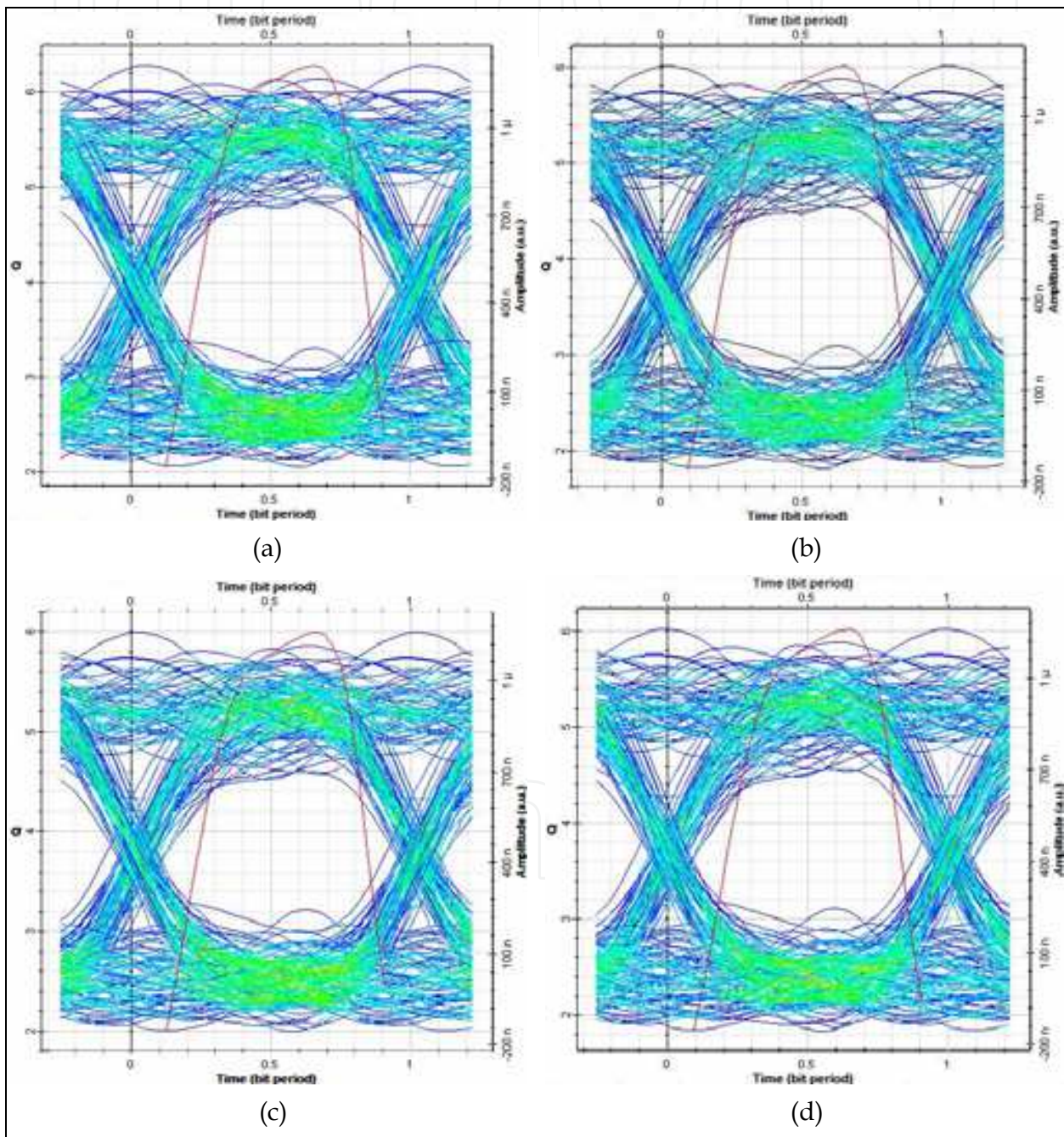

Fig. 8. The eye diagram of Q-factor for MROS with multiple splitting ratio, (a) 10 %, (b) 20 %, (c) 30 %, and (d) 40 %

Splitting Ratio	Maximum Distance	Q-factor	BER
10 %	51 km	6.27631	$1.7213 \times 10^{-10}$
20 %	60 km	6	$9.33852 \times 10^{-10}$
30 %	69 km	5.99	$1.003919 \times 10^{-9}$
40 %	76 km	6.0242	$8.431 \times 10^{-10}$

Table 1. The maximum distance, Q-factor, and BER for MROS with different splitting ratios

### 3.2.2 Long reach distance with Multi Ratio Optical Splitter (MROS)

ACS contains a new optical splitting device named MROS for improving the efficiency of data delivery to the customer premises/subscribers through optimizing the magnitude power distribute to each line connected to ONU (see Figure 7). In the real condition, the optical line for every home is terminated unevenly; therefore this device is designed to overcome such problem. MROS splits the input power to output power with ratio 10%, 20%, 30%, and 40%. It reduces the losses during data transmission because the optical power of input signal is distributed according to the distance between the MORS and ONU sides. Apart from that, various usage of this device does not require any amplifier to amplify the optical power of sharing signal to different distance. With MROS, the maximum achievable distance of the network system (from OLT to ONUs) can be expanding more than 20 km as compared to the conventional PON which uses the homogeneity splitting splitter (Rahman et al., 2009).

From the simulation using the OptiSystem CAD program by Optiwave System Inc, with 40 % output power from the MROS, the maximum distance that can be achieved is 76 km. For 30 %, 20 %, and 10 % splitting ratios, the maximum distance are 69 km, 60 km, and 51 km, respectively. The system sensitivity is set at - 35 dBm, the eye diagram of Q-factor for MROS with different splitting ratios is depicted in Figure 8 and the details can be seen in Table 1.

### 3.2.3 Remote access control for OTDR test module

FTB-400 Universal Test System provided courtesy of EXFO Electro-Optical Engineering Inc uses as an OTDR in this study. FTB-400 is chosen due to low cost and high dynamic range

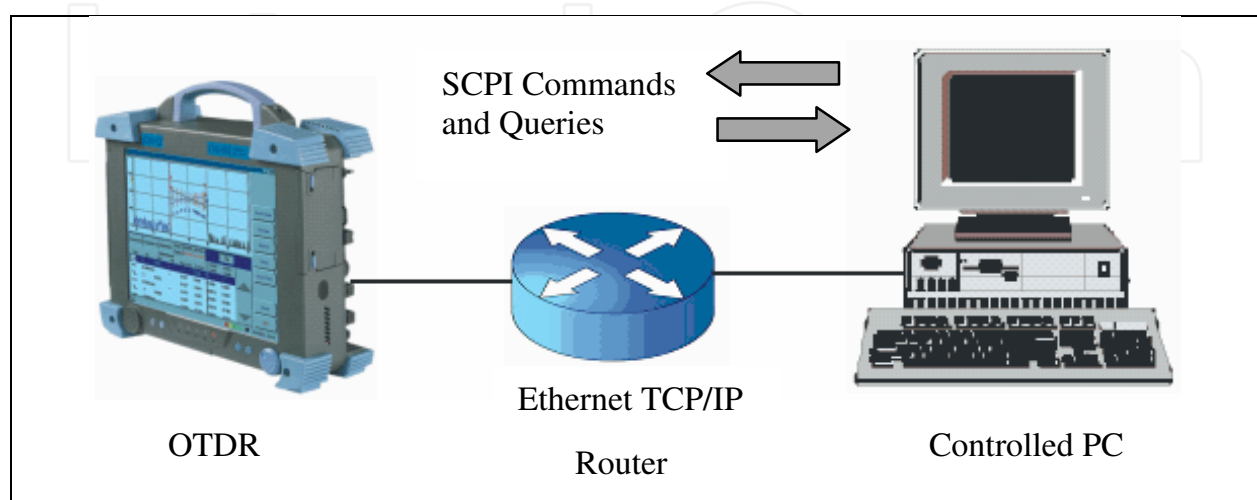

Fig. 9. Ethernet remote interface

up to 45 dB that ideal for long-haul networks. The OTDR test module is accomplished to an operator's remote workstation (PC/laptop) through the 10/100 Ethernet port running using Microsoft Visual Basic 2008 platform. The Ethernet remote interface allowed the users to access (connect) the OTDR test module over any Internet-connected PC as depicted in Figure 9. Integrated in an Ethernet LAN, such instrument can directly exchange data with various documentation tools or be remotely controlled. This enable the users to run and operate the OTDR test module from a remote PC/laptop at CO, point of link control (remote site), or distant monitoring easily in real time anywhere at any time without on-site personnel.

### 3.2.4 Acquisition configuration

SANTAD is automatically set the acquisition configuration (testing parameters) of FTB-400 when emitting the OTDR pulse; however it may be necessary to manually set the testing parameters in order to obtain the desired results. Besides the 1625 nm testing signal is reserved for live network monitoring, there are another three parameters as described below:

1. Distance range - Determine the maximum distance at which the OTDR will detect an event.
2. Pulse width - Determine the time width (duration) of the pulse that is send by OTDR. A longer pulse travels further down the fiber and improves the signal-to-noise ratio (SNR), but results in less resolution, making it more difficultly to separate closely spaced event. A longer pulse also results in longer dead zones. In contrast, a shorter pulse width provides higher resolution and shorter dead zones, but less distance range and lower SNR. Generally, it is preferable to select the shortest possible pulse width, enabling to see everything and then proceed to make further adjustments for optimization. When testing downstream in FTTH, the optical power of the OTDR pulse must be large enough to go through the splitter and the dynamic range must be high.
3. Acquisition time - Longer acquisition times (time period during which test results are averaged) produce cleaner traces (especially with long distance traces) due to the fact that as the acquisition times increases, more of the noise is averaged out; this averaging increases the SNR and the ability of the OTDR to detect small and closely spaced events. When performing a quick test, in order to locate a major fault, such as a break, a short acquisition time should be used (e.g., 10 s). To fully characterize a link with optimal precision and to make sure the end-to-end loss budget is respected, a longer acquisition time (45 s to 3 min) is preferable (EXFO, 2006 & EXFO, 2008).

### 3.2.5 Centralized monitoring and advanced data analyzing

The principle enhancement of SANTAD detection is best explained in Figure 10. In order to execute the distinctive management operations, all the OTDR measurement are recorded in database and then loaded into the developed program for further analyzing. SANTAD accumulated all OTDR measurement into a single PC screen for centralized monitoring and advanced data analyzing. Every 8 OTDR measurements will be displayed in *Centralized Monitoring* form for centralized monitoring and advanced data analyzing. SANTAD is focusing on providing survivability through event identification against losses and failures. A failure notification "*Line x FAILURE at z km from CO!*" will be displayed and send to the field engineers if SANTAD detect any occurrence of fiber failures/faults in the network

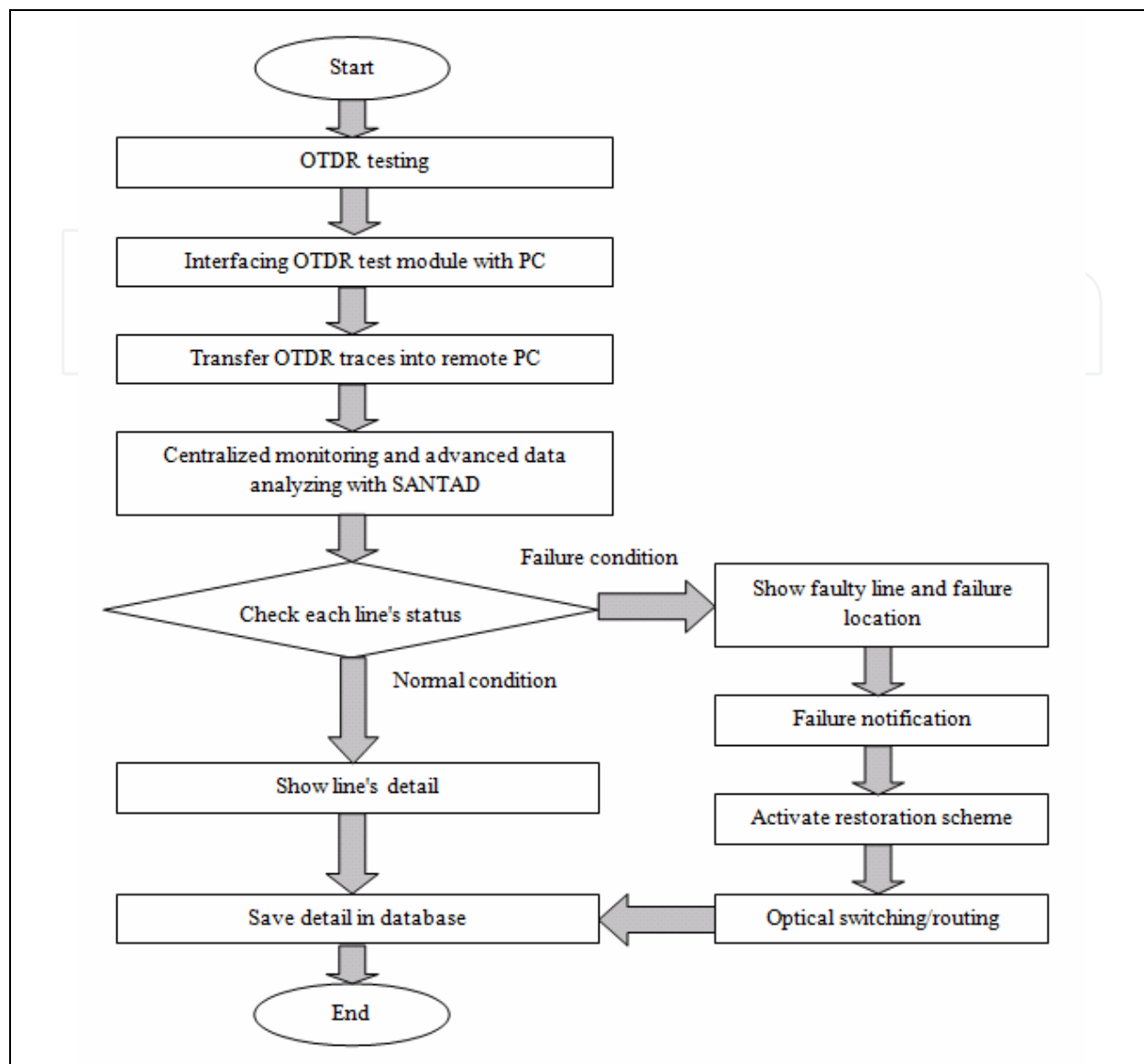

Fig. 10. System's flow diagram for mechanism of failure detection and restoration

system. By monitoring such parameters, any occurrence of fault in the network system can be identified by a drastic drop of optical power level. The failure status in the network system will be sent to the field engineers via free e-mail service.

To obtain further details on the performance of specific line in the network system, every measurement results obtained from the network testing are analyzed in the *Line's Detail* form. The developed program is able to identify and present the parameters of each optical fiber line such as the line's status, the magnitude of attenuation as well as the location, and other details (breakdown location, line's parameter such as return loss, crosstalk, etc.) are shown in the computer screen. By monitoring such parameters, SANTAD can distinguish failures, thus eliminating unnecessary field trips for maintenance. The advantage of this feature as compared to the OTDR and computer-based emulation software is SANTAD displayed every status for the testing line in the *Line's Detail* form which display onto one screen board. A "Good condition" or "Decreasing  $y$  dB at  $z$  km" message displays at the line's status panel in a working condition. However in a failure condition, a failure message "Line

*x FAILURE at z km from CO!*" displays to show the exact failure location in the network system. It is flexible and easy to use for those who are inexperienced in the optical fiber testing by just reading the information gain from the messages.

### 3.3 Prototype implementation

The lab prototype of SANTAD is implemented in a PON network at Universiti Kebangsaan Malaysia (UKM) composed by 20 km fiber as depicted in Figure 11 for analyzing the network performance. The length of feeder fiber is 15 km. The fiber link in the distribution region between the optical splitter and each ONU is about 5 km. In normal operation, both the upstream and downstream signals travel through a transmission distance of 20 km from OLT towards each ONU.

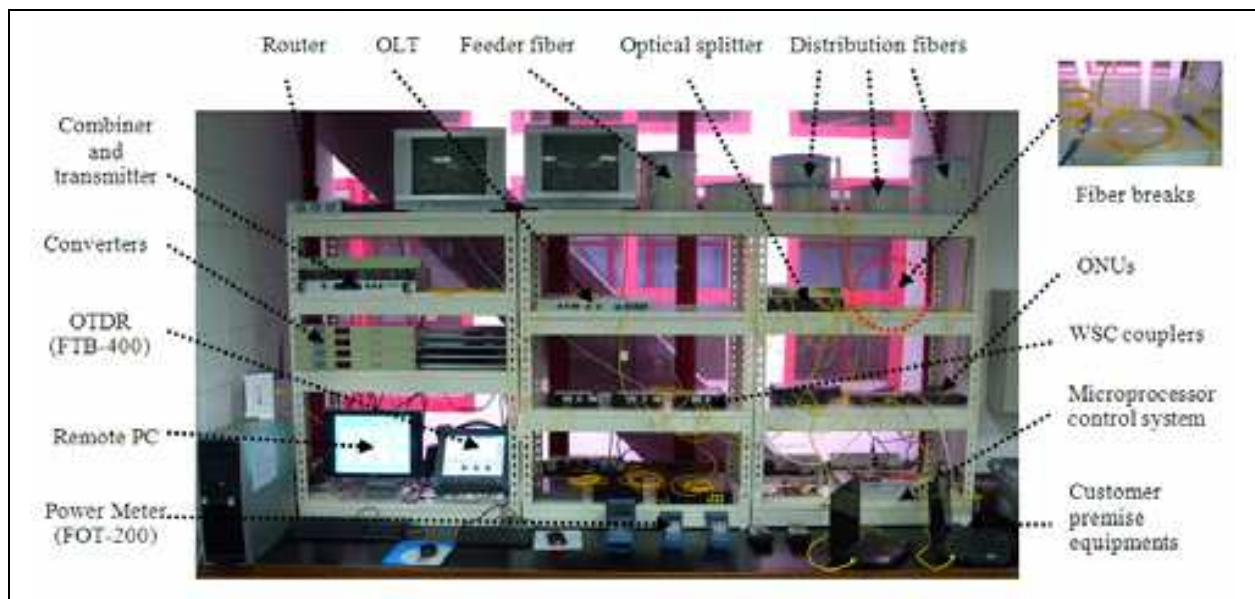

Fig. 11. Photographic view of the prototype implementation of SANTAD in PON network

We conducted an experiment for evaluating our in-service fault localization methodology as an appropriate technique in our proposed design. Here we are specially focusing on identifying the link failures in the network system. As a first step, no default was introduced in the network system and OTDR measurements are performed. In this research, the characterization measurements will be analyzed based on different connections in the drop region. The fiber link between the optical splitter and the ONU is intentionally disconnected to represent a fiber break scenario at a distance of 15 km. It visualized the actual break point of an optical line at that distance in a real condition.

Our in-service fault localization results are presented in Figure 12. Figure 12a depicts the capability of SANTAD to configure the optical signal level and attenuation/losses through event identification method. The failure location is identified by a drastic drop of optical power level. Figure 12b and 12c illustrates the further details of the specific testing line in the network system. The analysis results will then be stored in a text file acting as a database with certain attributes such as date and time, network failure rate, failure location, etc. All kinds of additional information can be easily accessed and queried later. The database system enables the history of network scanning process to be analyzed and studied by the field engineers, as illustrated in Figure 13, which may require some prompt actions.

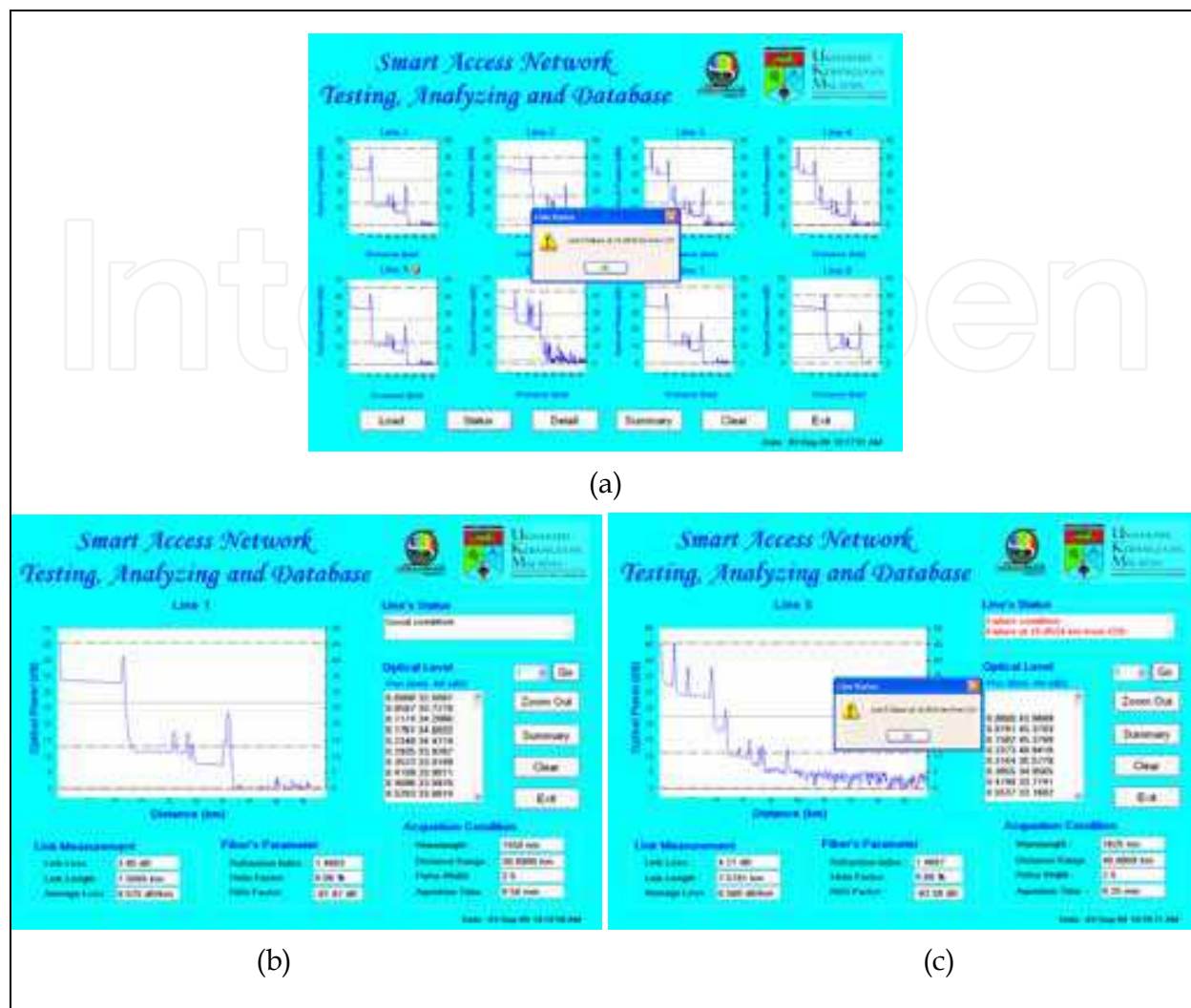

Fig. 12. (a) Execution display in *Centralized Monitoring* form, (b) An example of normal condition, and (c) An example of failure condition in *Line's Detail* form

The interface between network service providers or operators and field engineers is customized web browser (see Figure 14). This web page allows network operators and field engineers to test and troubleshoot any leg of PON by accessing an OTDR test module by just connect a laptop or personnel digital assistant (PDA) to a LAN or web browser tools such as Internet Explorer or Firefox to access this applications. The status of each line is automatically updated to a web server by ACS which can access by remote monitor via Internet or LAN. The website is stored in the PIC18F97J60 microcontroller, besides this, for the display of the real-time system, the web browser is also of vital importance, as it can be only accessed via Internet. The network operators and field engineers can read and identify the status of each fiber line timely from CO or remote site without making a site visit before taking some appropriate actions. The field engineers can remote controlling the operation of the optical switching for switching the traffic or routing the optical signals in supporting devices from this web page. Once the instruction from the web page received, the microcontroller in the supporting devices will run is the specific algorithm to control the optical switch either in manual mode or automatic mode.



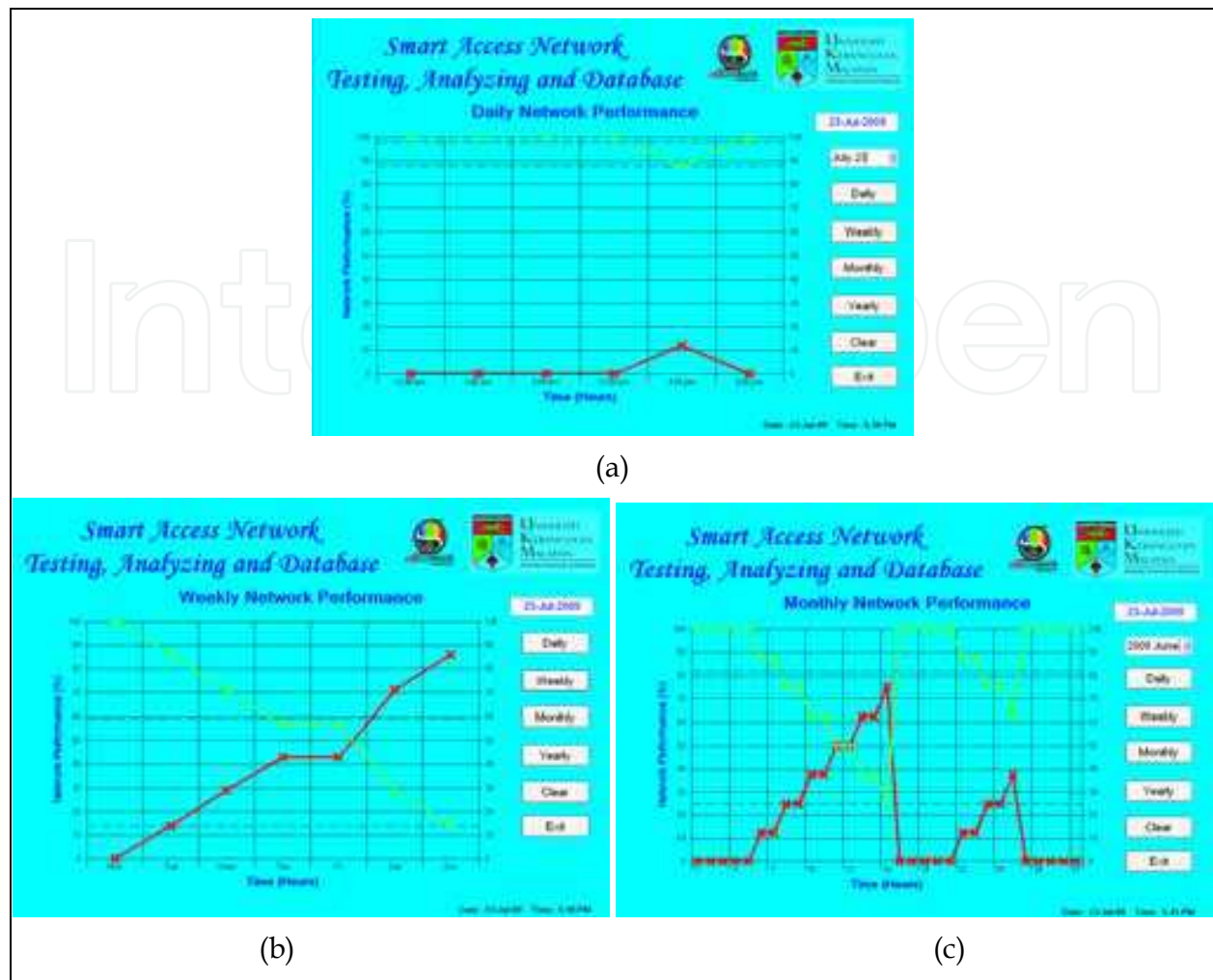

Fig. 13. Analysis of the relationship between network failure rate and network performance; (a) Daily network performance, (b) Weekly network performance, and (c) Monthly network performance

#### 4. Smart Drop Protection Scheme (SDPS)

Smart Drop Protection Scheme (SDPS) is implemented in the drop region of PON to provide self-protection and restoration capabilities against fiber failures/faults. Link failures are the most common and occur when a fiber cable is accidentally cut when digging in an area through which fiber cables pass. Protection can be performed at the level of an individual light path or at the level of a single fiber. Path protection denotes schemes for the restoration of a light path, and link protection denotes schemes for the restoration of a single fiber (Perros, 2005). In our SDPS design, the transmission link in drop region is protected in a non-dedicated 1:1 manner. An additional fiber is connected together with the drop fibers between the optical splitter at the remote node (RN) and ONUs at customer sites as protection line (backup line). SDPS utilizes different routing mechanisms to divert the distributed signals from failure line to protection line or neighbor line according to the types of failure condition and location. The protection switching in SDPS is carried out using an additional device named Customer Access Protection Unit (CAPU).

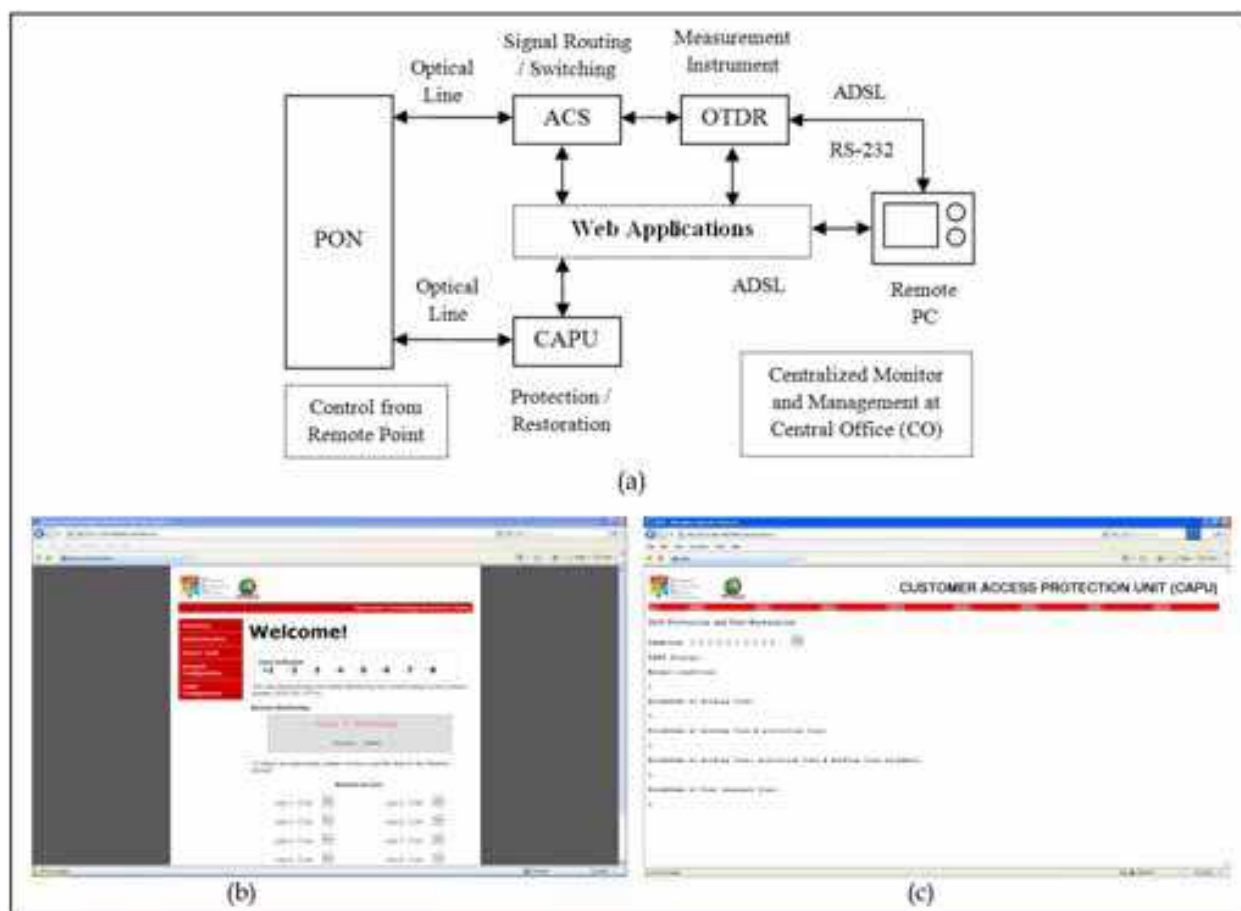

Fig. 14. (a) Web service application for multi interfacing, (b) Web-based remote control and monitoring applications for ACS, and (c) Web-based remote control and monitoring applications for CAPU

#### 4.1 Failure detection with Multi Access Detection System (MADS)

In our proposed system, 2 supported devices have been developed; ACS and MADS. MADS is used to identify the faulty line by tapping a small ratio of traffic flow. The status of each transmission link is sent to the assemble point in the ACS by using radio frequency (RF) signal. Any damage traced by SANTAD would be referred with MADS before restoration scheme grew. The activated restoration scheme is depend to the failure location and the activation signal is sent through the ADSL line to each optical switch which involved of the particular scheme.

The MADS system model is shown in Figure 15. Since the triple-play signals are combined at CO, therefore these signals are required to be split according to their respective wavelengths (1310 nm and 1480 nm for data and voice signals and 1550 nm for video signal) by using passive components configuration for monitoring purposes. In this configuration, the video signal will be split again into a 90:10 ratio. The 90% video signal will recombine with 1310 nm and 1480 nm signals, and transmitted to ONU before distributed to the users; while an optical-to-electrical (O/E) converter is used to convert the other 10% signal to electrical signal. In the next stage, CATV electrical signal will be sent to max7461 module. This module is able to convert the video signal to 1-bit signal. The 1-bit signal from every wireless transmitter will be sent to wireless receiver at the assembly point in ACS. ACS will

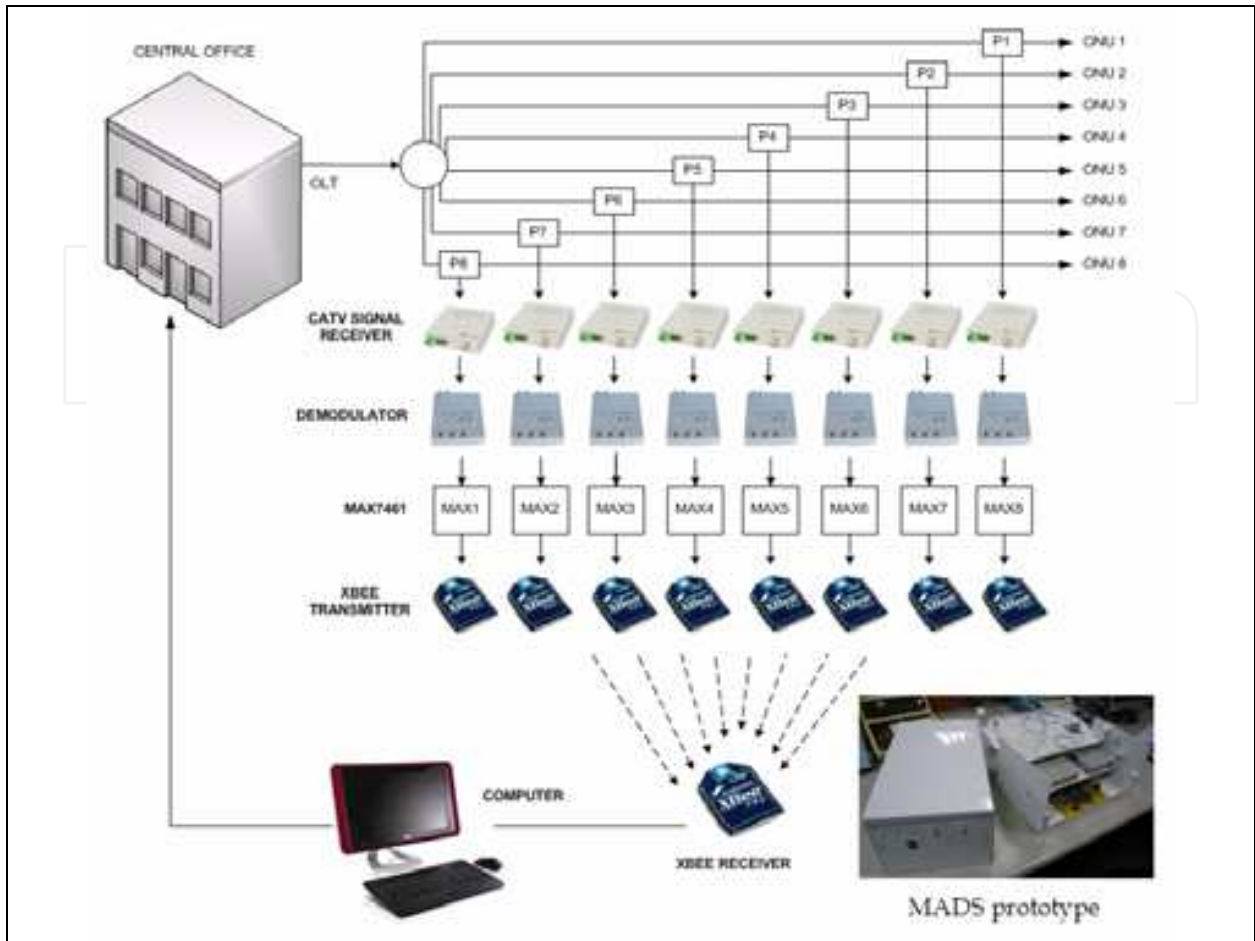

Fig. 15. Multi Access Detection System (MADS) system model

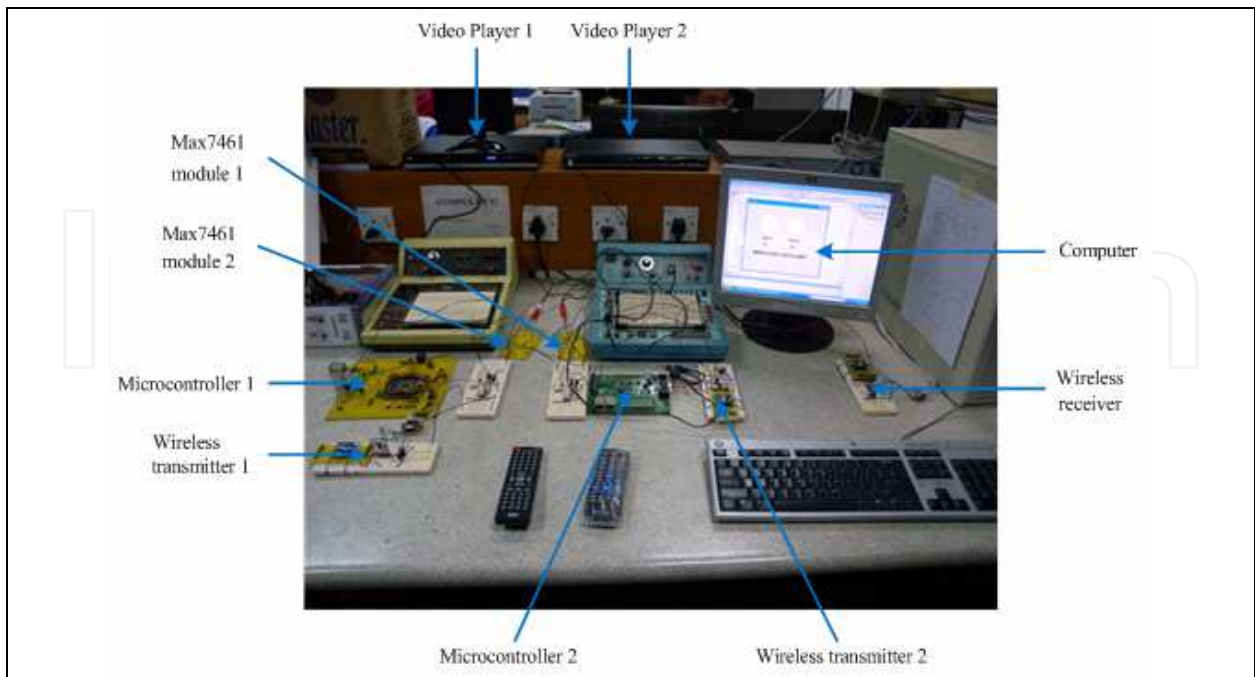

Fig. 16. Experimental set up for indentifying the propagation signal (the video signal is fed into the MADS to represent the video signal transmission in PON)

translate the failure into codes, which is specified by the failure type and the suitable restoration scheme to be activated. Then the codes are sent to the respective ONUs to perform the restoration scheme. The experimental set up for MADS is illustrated in Figure 16. Figure 17 represents the successful failure detection by using MADS. The computer plays a warning sound (alarm) if there is failure occur in the PON network system.

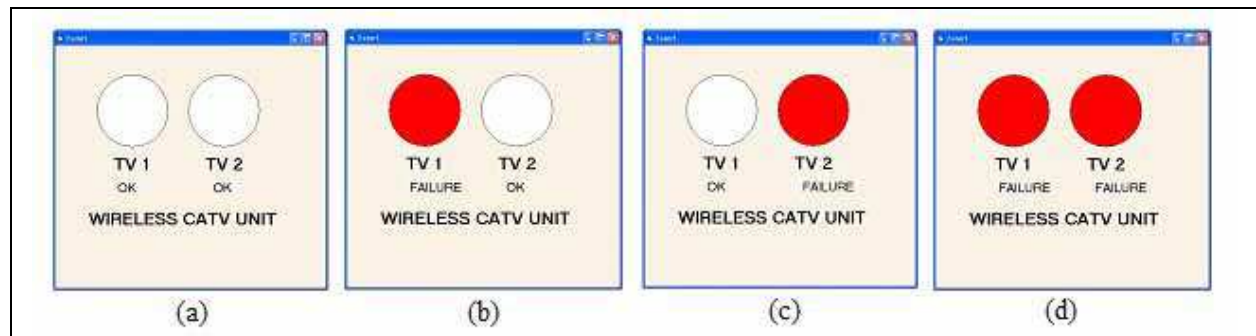

Fig. 17. The status of each transmission line is displayed on a computer screen, red circle indicates failure occurs in the specific line; (a) Both video players are “On”, (b) Video player 1 is “Off” and 2 is “On”, (c) Video player 1 is “On” and 2 is “Off”, and (d) Both video players are “Off”

#### 4.2 Failure link recovery with Customer Access Protection Unit (CAPU)

CAPU is an optical programmable switch device (OPSD) designed as a package that offered for the ease of customers to perform security and self restoration at the end-users side. CAPU comprises of 1x2 and 2x2 optical switches as well as a microcontroller system switching the distributed signals to the protection line or neighbor line when failure occurs in the working line (see Figure 18). Two optical switches are allocated in the transmission fiber link as optical selector; one is designated to switch the distributed signals from failure line to the protection line or transmission line nearby, while another will switch the signals back to the original path after bypass the failure point. Both optical switches are coupled with an ADSL copper wire from the CO through ACS.

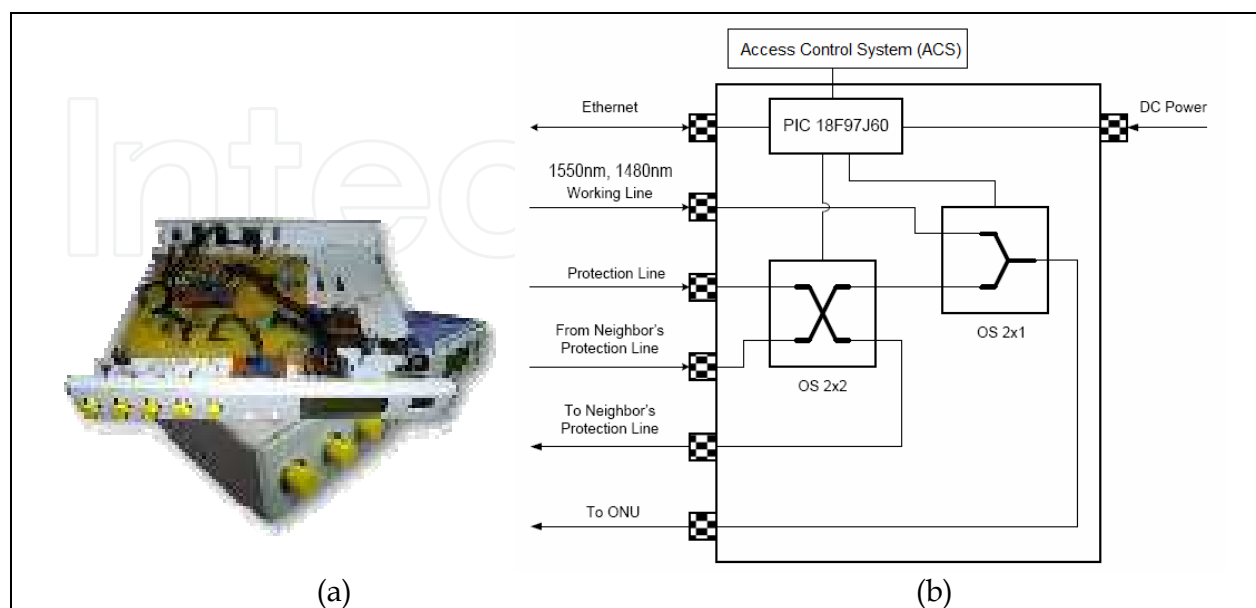

Fig. 18. Customer Access Protection Unit (CAPU), (a) Lab prototype and (b) Schematic diagram

ACS controls the optical switch device for path selective in normal operation and failure condition. In normal condition, the upstream and downstream signals of each ONU are transmitted through their corresponding fiber. However, in case of SANTAD detects any occurrence of fiber fault or transmission failure in the drop region by monitoring the optical power, losses, and attenuation from CO, it will identify the faulty line and address the failure location. Then ACS recognizes the types of failure and sends the activation signals to the microcontroller to trigger the related optical switches to transfer the disrupted signals to the other fiber link according to the activated protection mechanisms. The route depends on the restoration mechanism that is activated according to the types of failure as depicted in Figure 19.

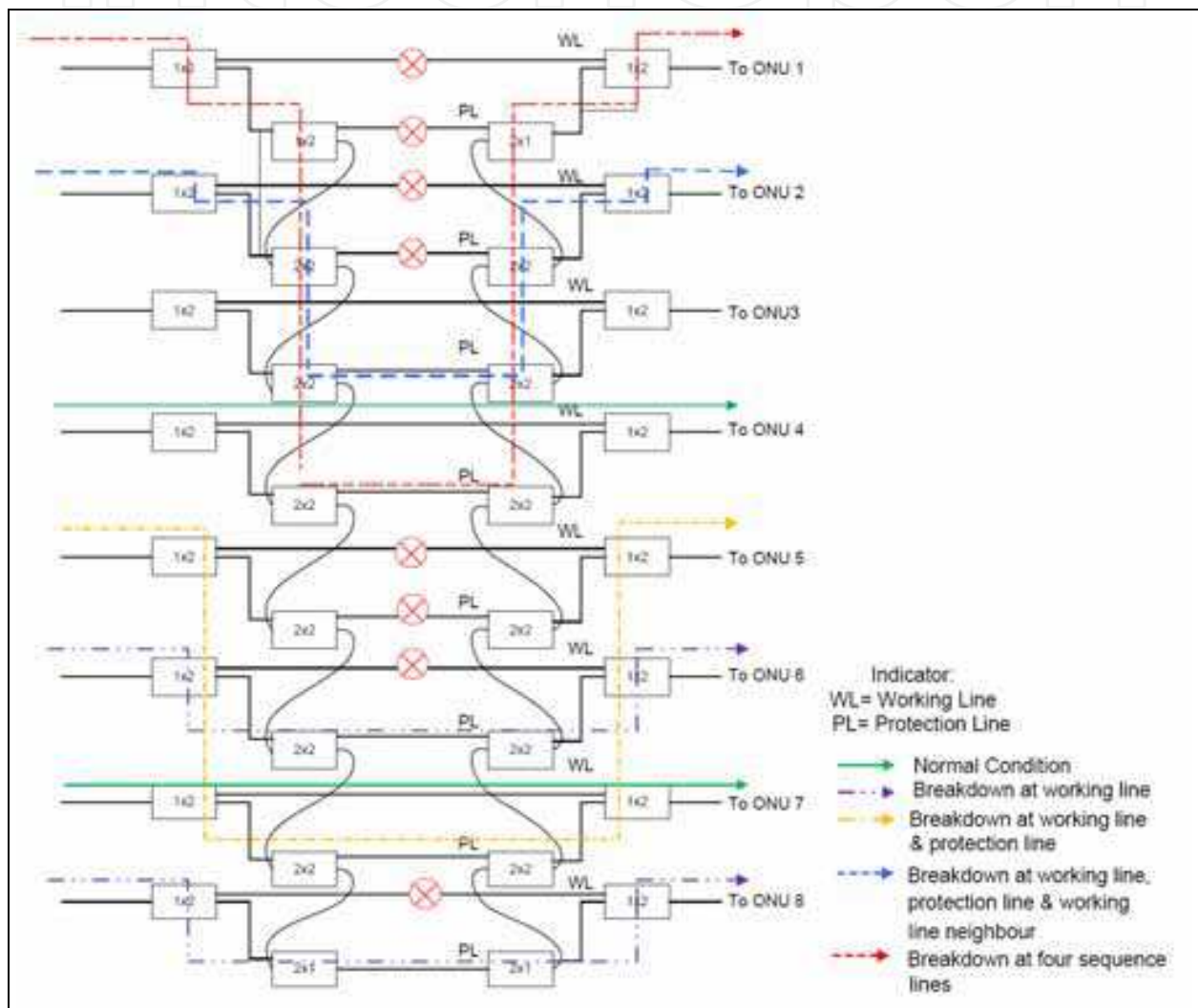

Fig. 19. Protection mechanisms in PON

#### 4.3 Simulation results in -34 dBm receiver sensitivity

The PON based network design is modelled and simulated using the Optisystem CAD program by Optiwave System, Inc. All figures below depict the protection mechanism design for PON network system. The downstream optical signals (with  $\lambda_1 = 1480$  nm and  $\lambda_2 = 1550$  nm) will be transmitted from CO through the feeder region and then entered the distribution region after passing the optical splitter. The optical signals will be divided into 8 route signals

evenly in the distribution region. For this simulation, we set the receiver sensitivity at -34 dBm and other parameters as listed in Table 2 by using the SPO optimization. Our results are obtained by observing bit error rates (BERs), eye diagrams, optical power levels, and dispersion levels. Figure 20 till 23 present the eye diagrams with Max Q factor and Min BER at each ONU for the 1550 nm, 1480 nm, and 1310 nm signals, respectively.

Component	Parameter Type	Value
PBRs Generator	Upstream Bit Rate (Gbps)	1.25
	Downstream Bit Rate (Gbps)	1.25 (symmetrical)
Electrical Generator	Rise Time/ Fall Time	0.05 bit
Light Source	Downstream Wavelength(nm)	1480, 1550
	Upstream Wavelength (nm)	1310
Modulator	Modulation Format	NRZ
Multiplexer/Demultiplexer	Insertion Loss (dB)	0.5
Bidirectional Splitter (1:8)	Insertion Loss (dB)	5
Circulator Bidirectional	Insertion Loss (dB)	1
Bidirectional Optical Fiber	Attenuation Constant (dB/km)	0.25

Table 2. Simulation parameters

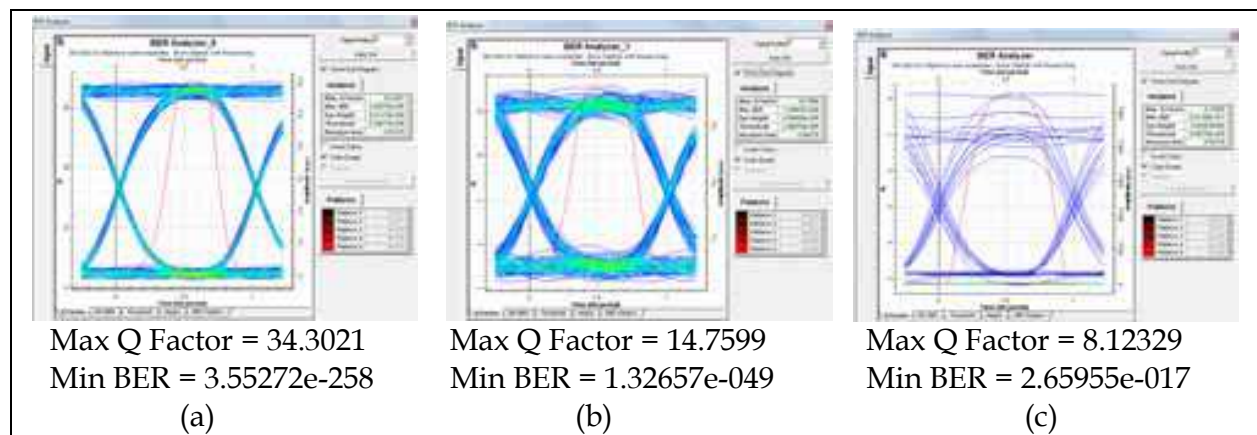

Fig. 20. Max Q factor and Min BER at ONU 1 for (a) 1550 nm downstream signal, (b) 1480 nm downstream signal (c) 1310 nm upstream signal in condition A

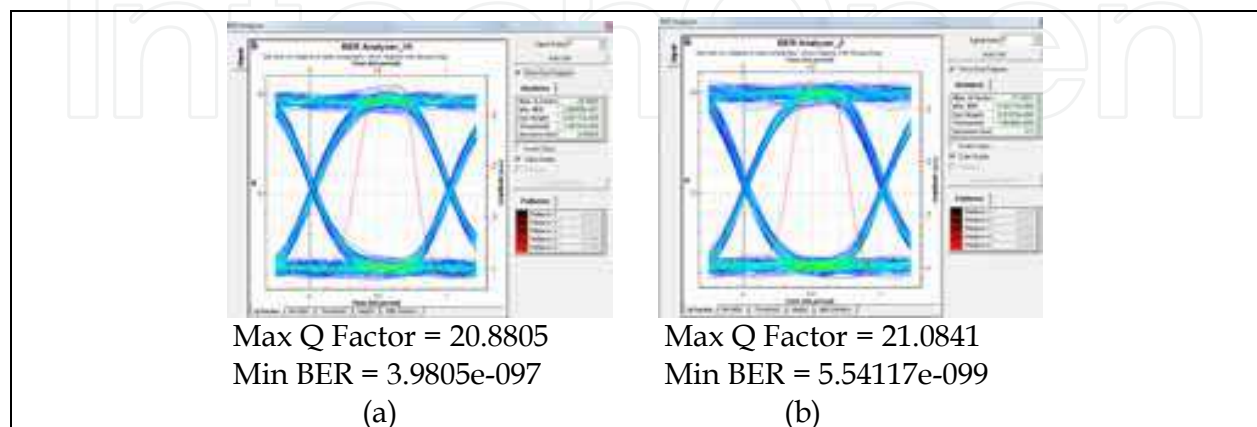

Fig. 21. Max Q factor and Min BER at ONU 2 for (a) 1550 nm downstream signal and (b) 1480 nm downstream signal in condition B

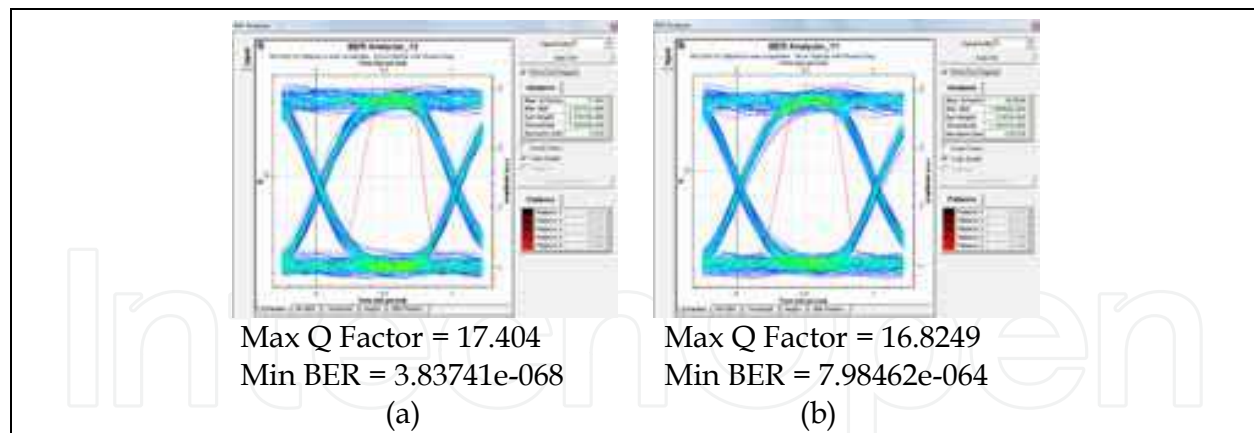

Fig. 22. Max Q factor and Min BER at ONU 3 for (a) 1550 nm downstream signal and (b) 1480 nm downstream signal in condition C

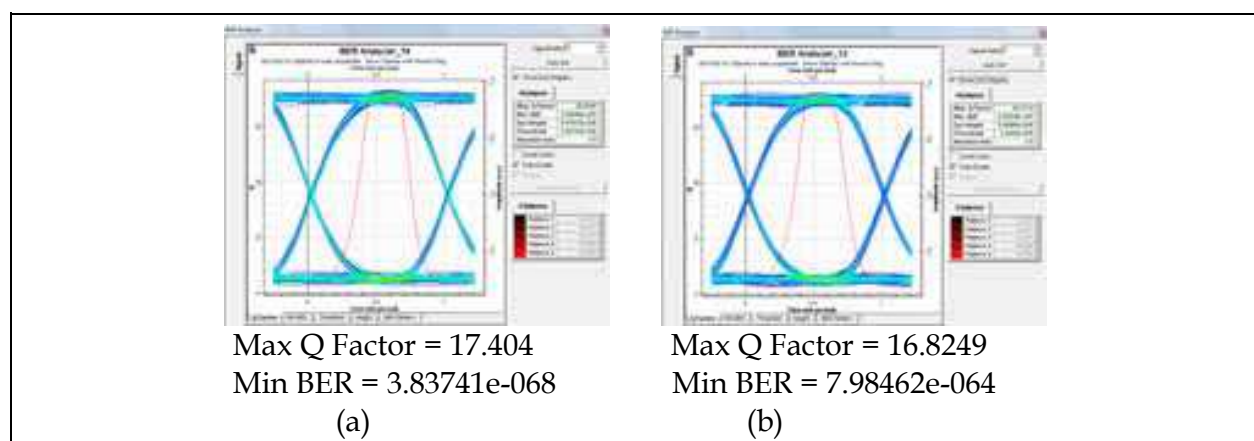

Fig. 23. Max Q factor and Min BER at ONU 4 for (a) 1550 nm downstream signal and (b) 1480 nm downstream signal in condition C

## 5. Conclusions

Locating fiber degradation or failures/faults within PON becomes more significant due to the increasing demand for reliable service delivery. An appreciate approach is proposed in this paper as a measurement strategy PON with improved performance. The experimental results show the proposed approach is very feasible and efficiency to be implemented in PON as an appreciate technique for detecting any fiber degradation or failures/faults and details regarding faults, such as faulty line and failure location, are provided to the field engineers and technicians within 30 seconds. This enhancement is contributed to:

- Testing a live network
- Help to prevent, identify and address problem
- Set-up a mechanism of interactive connection between CO and customers/end users
- Overcome the monitoring issues in PON by using conventional OTDR upwardly or downwardly
- Reduce/save time and cost
- Increase survivability, efficiency, and flexibility of PON with tree topology or P2MP configuration

The main advantages of this work are to assist the network operators to manage the PON network system more efficiently, facilitate the network management through centralized monitoring and troubleshooting from CO, increase the workforce productivity, reduce hands on workload, minimize network downtime, and rapidly restore failed services when problems are detected and diagnosed.

## 6. Acknowledgement

This research work is supported by Ministry of Science, Technology and Innovation (MOSTI), Government of Malaysia, through the National Science Fund (e-Science) 01-01-02-SF0493. The authors would like to appreciate Aswir Premadi, Mohamad Najib Mohd. Saupe, Siti Asma Che Aziz, Siti Rahayu Hassan, and Mastang for their valuable contribution and technical support in this research.

## 7. References

- Anderson, D.R.; Johnson, L. & Bell, F.G. (2004). *Troubleshooting Optical Fiber Networks Understanding and Using Optical Time-domain Reflectometers*, Academic Press, Elsevier, California, US, ISBN: 1417537205
- Bakar, A.A.A.; Jamaludin, M.Z.; Abdullah, F.; Yaacob, M.H.; Mahdi, M.A. & Abdullah, M.K. (2007). A New Technique of Real-time Monitoring of Fiber Optic Cable Networks Transmission. *Optics and Lasers in Engineering*, Vol. 45, (2007) 126-130, ISSN: 0143-8166
- Barnoki, M.K. & Jensen, S.N. (1976). Fiber Waveguides: a Novel Technique for Investigating Attenuation Characteristics. *Applied Optics*, Vol. 15, (1976) 2112-2115, ISSN: 0003-6935
- Chan, C.K.; Tong, F.; Chen, L.K.; Ho, K.P. & Lam, D. (1999). Fiber-fault identification for branched access networks using a wavelength-sweeping monitoring source. *IEEE Photonics Technology Letters*, Vol. 11, No. 5, (1999) 614-616, ISSN: 1041-1135
- Chan, C.K. (2007). Chapter 6: Protection Architectures for Passive Optical Networks, *Passive Optical Networks Principles and Practice*, Academic Press, Elsevier, 243-266
- Corning. (2005). Broadband Technology Overview, Available: <http://www.corning.com/docs/opticalfiber/wp6321.pdf>
- EXFO. (2006). *FTB-400 Universal Test System User Guide*, EXFO Electro-Optical Engineering Inc, Quebec City, Canada
- EXFO. (2008). *FTTx PON Guide Testing Passive Optical Networks*, EXFO Electro-Optical Engineering Inc, Quebec City, Canada
- EXFO. (2008). *Guide to WDM Technology and Testing*, 3<sup>rd</sup> ed., ISSN: 1-55342-000-4, EXFO Electro-Optical Engineering Inc, Quebec City, Canada
- Gorshe, S.S. (2006). FTTH Technologies and Standards Industrial Highlights, Available: [www.ezcom.cn/English/digital%20library/200612/13.pdf](http://www.ezcom.cn/English/digital%20library/200612/13.pdf)
- Keiser, G. (2000). *Optical Fiber Communication*, 3<sup>rd</sup> ed., McGraw Hill, New York, ISBN:1661-8211
- King, D.; Lyons, W.B.; Flanagan, C. & Lewis, E. (2004). Interpreting Complex Data from a Three-sensor Multipoint Optical Fiber Ethanol Concentration Sensor System using Artificial Neural Network Pattern Recognition. *Measurement Science Technology*, Vol. 15, (2004) 1560-1567, ISBN: 0957-0233



- Mukherjee, B. (2006). *Optical WDM Networks (Optical Networks)*, Springer, ISBN: 978-0-387-29055-3.
- Perros, H.G. (2005). *Connection-oriented Network SONET/SDH, ATM, MPLS and Optical Networks*, John Wiley & Sons Ltd, England.
- Prat, J. (2007). Optical Networks: Towards Bandwidth Manageability and Cost Efficiency, Available: [http://www.e-photon-one.org/ephotonplus/servlet/Utils.MostrarFitxerPublic?fitxer=D\\_VD-A\\_3.pdf&pathRelatiu=E-Photon+One+%2B%2FPublic%2FPublic+Deliverables%2F](http://www.e-photon-one.org/ephotonplus/servlet/Utils.MostrarFitxerPublic?fitxer=D_VD-A_3.pdf&pathRelatiu=E-Photon+One+%2B%2FPublic%2FPublic+Deliverables%2F)
- Rahman, M.S.A.; Md-Zain, N.; Baharuddin, A. & Jumari, K. (2009). Multi Ratio Optical Splitter (MROS) based on planar waveguide. *Proceedings of Asia Pacific Conference on Defence & Security Technology (DSTC 2009)*, paper DSTC-081, Kuala Lumpur, Malaysia, 6-7 October 2009
- Rahman, M.S.A.; Rashid A.R.A.; Ehsan A.A. & Shaari, S. (2008). The Characterization of FTTH Wavelength Selective Coupler. *Proceedings of 2008 IEEE International Conference on Semiconductor Electronics (ICSE 2008)*, pp. 302-305, Johor Bahru, Malaysia, 25-27 November 2008
- Skubic, B.; Chen, J.; Ahmed, J.; Wosinka, L. & Mukherjee, B. (2009). A Comparison of Dynamic Bandwidth Allocation for EPON, GPON, and Next Generation TDM PON. *IEEE Communications Magazine*, Vol. 47, No. 3, (March 2009) S40-S48, ISSN: 0163-6804
- Wosinska, L.; Colle, D.; Demeester, P.; Katrinis, K.; Lackovic, M.; Lapcevic, O.; Lievens, I.; Markidis, G.; Mikac, B.; Pickavet, M.; Puype, B.; Skorin-Kapov, N.; Staessens, D. & Tzanakaki, A. (2009). Chapter 9: Network Resilience in Future Optical Networks, *Towards Digital Optical Networks*. Springer Berlin / Heidelberg, 253-284, ISBN: 978-3-642-01523-6

IntechOpen



## **User Interfaces**

Edited by Rita Matrai

ISBN 978-953-307-084-1

Hard cover, 270 pages

**Publisher** InTech

**Published online** 01, May, 2010

**Published in print edition** May, 2010

Designing user interfaces nowadays is indispensably important. A well-designed user interface promotes users to complete their everyday tasks in a great extent, particularly users with special needs. Numerous guidelines have already been developed for designing user interfaces but because of the technical development, new challenges appear continuously, various ways of information seeking, publication and transmit evolve. Computers and mobile devices have roles in all walks of life such as in a simple search of the web, or using professional applications or in distance communication between hearing impaired people. It is important that users can apply the interface easily and the technical parts do not distract their attention from their work. Proper design of user interface can prevent users from several inconveniences, for which this book is a great help.

### **How to reference**

In order to correctly reference this scholarly work, feel free to copy and paste the following:

Boonchuan Ng, Mohammad Syuhaimi Ab-Rahman and Kasmiran Jumari (2010). Graphical User Interface for PON Network Management System, User Interfaces, Rita Matrai (Ed.), ISBN: 978-953-307-084-1, InTech, Available from: <http://www.intechopen.com/books/user-interfaces/graphical-user-interface-for-pon-network-management-system>

**INTECH**  
open science | open minds

### **InTech Europe**

University Campus STeP Ri  
Slavka Krautzeka 83/A  
51000 Rijeka, Croatia  
Phone: +385 (51) 770 447  
Fax: +385 (51) 686 166  
[www.intechopen.com](http://www.intechopen.com)

### **InTech China**

Unit 405, Office Block, Hotel Equatorial Shanghai  
No.65, Yan An Road (West), Shanghai, 200040, China  
中国上海市延安西路65号上海国际贵都大饭店办公楼405单元  
Phone: +86-21-62489820  
Fax: +86-21-62489821

© 2010 The Author(s). Licensee IntechOpen. This chapter is distributed under the terms of the [Creative Commons Attribution-NonCommercial-ShareAlike-3.0 License](#), which permits use, distribution and reproduction for non-commercial purposes, provided the original is properly cited and derivative works building on this content are distributed under the same license.

IntechOpen

IntechOpen