

We are IntechOpen, the world's leading publisher of Open Access books Built by scientists, for scientists

4,800

Open access books available

122,000

International authors and editors

135M

Downloads

Our authors are among the

154

Countries delivered to

TOP 1%

most cited scientists

12.2%

Contributors from top 500 universities



WEB OF SCIENCE™

Selection of our books indexed in the Book Citation Index
in Web of Science™ Core Collection (BKCI)

Interested in publishing with us?
Contact book.department@intechopen.com

Numbers displayed above are based on latest data collected.

For more information visit www.intechopen.com



Cooperative MIMO Systems in Wireless Sensor Networks

M. Riduan Ahmad¹, Eryk Dutkiewicz², Xiaojing Huang³ and M. Kadim Suaidi⁴

^{1,4}Universiti Teknikal Malaysia Melaka, ²Macquarie University, ³CSIRO ICT Centre

^{1,4}Malaysia, ^{2,3}Australia

1. Introduction

The Multiple-Input Multiple-Output (MIMO) term originally describes the use of the multiple antennas concept or exploitation of spatial diversity techniques. In early research work, the MIMO concept was proposed to fulfil the demand for providing reliable high-speed wireless communication links in harsh environments. Subsequently, MIMO technology has been proposed to be used in wireless local area networks and cellular networks, particularly at the base station and access point sides to tackle the challenges of low transmission rates and low reliability with no constraints on energy efficiency. In contrast, Wireless Sensor Networks (WSNs) have to deal with energy constraints due to the fact that each sensor node depends on its battery for its operation. In harsh environments, sensor nodes must be provided with reliable communication links. However, current WSN design requirements do not require high transmission rates.

The concept of cooperative MIMO was introduced in WSNs by utilizing the collaborative nature of dense sensor nodes with the broadcast wireless medium to provide reliable communication links in order to reduce the total energy consumption for each sensor node. Therefore, instead of using multiple antennas attached to one node or device such in the traditional MIMO concept, cooperative MIMO presents the concept of multiple sensor nodes cooperating to transmit and/or receive signals. Multiple sensor nodes are physically grouped together to cooperatively transmit and/or receive. Within a group, sensor nodes can communicate with relatively low power as compared to inter-group communication. Furthermore, by using this cooperative MIMO concept, we can provide the advantages of traditional MIMO systems to WSNs, particularly in terms of energy efficient operation.

This chapter introduces the concepts of diversity techniques and their relationship with cooperative MIMO systems and to discuss their practicality for implementation in WSNs. The approaches that we are going to use in this chapter are the comparative study and performance evaluation of major diversity techniques and their implementations in cooperative MIMO systems. The outcomes can be used as the basis for further study in order to find the most suitable cooperative MIMO scheme to be implemented in the WSN environment.

The rest of the chapter is organized as follows. Section 2 introduces the concept of cooperative MIMO and Section 3 explains various types of diversity techniques proposed in the current literature. A comparative study between the major diversity techniques is presented in Section 4 and this is followed by performance evaluation in Section 5. Finally, in Section 6 we conclude the chapter.

2. Cooperative MIMO Concepts

The MIMO term originally describes the use of the multiple antennas concept or exploitation of spatial diversity techniques. In early research work, the MIMO concept was proposed to fulfil the demand for providing reliable high-speed wireless communication links in harsh environments. Subsequently, MIMO technology has been proposed to be used in wireless local area networks and cellular networks (Proakis, 2001), particularly at the base station and access point sides to tackle the challenges of low transmission rates and low reliability with no constraints on energy efficiency. In contrast, WSNs have to deal with energy constraints due to the fact that each sensor node depends on its battery for its operation. In harsh environments, sensor nodes must be provided with reliable communication links. However, current WSN design requirements do not require high transmission rates.

The concept of cooperative MIMO was introduced in WSNs by utilising the collaborative nature of dense sensor nodes with the broadcast wireless medium to provide reliable communication links in order to reduce the total energy consumption for each sensor node. Therefore, instead of using multiple antennas attached to one node or device such in the traditional MIMO concept, cooperative MIMO presents the concept of multiple sensor nodes cooperating to transmit and/or receive signals. Multiple sensor nodes are physically grouped together to cooperatively transmit and/or receive. Within a group, sensor nodes can communicate with relatively low power as compared to inter-group communication (Singh and Prasanna, 2003; Gupta and Younis, 2003; Yuksel and Erkip, 2004). Furthermore, by using this cooperative MIMO concept, we can provide the advantages of traditional MIMO systems to WSNs, particularly in terms of energy efficient operation.

3. Techniques of Diversity

In this section we discuss various diversity techniques to reduce the deep fading problem in WSNs which requires higher retransmission rates. By tackling this problem, we are clearly satisfying two design requirements: energy efficient operation and higher communication link reliability. It is important to observe that deep fading contributes to packet errors (if a portion of the packet is affected) or packet loss (if the whole packet is totally lost which can be common as data packets in WSNs are normally small (Kohvakka et. al., 2006; Karl and Willig, 2007). The basic concept of diversity is to provide the receiver with copies of independently faded transmitted packets with the hope that at least one of these copies will be received correctly. Diversity can be implemented in various ways such as frequency diversity, spatial diversity, time diversity, modulation diversity and polarisation diversity to suit different design requirements.

Frequency diversity is achieved when the same signal is transmitted over different frequency bands. The separation of the frequency bands has to be more than the coherence

bandwidth of the channel (Duman and Ghrayeb, 2007). Time diversity is achieved when the same signal is transmitted with redundancy using different time intervals. The separation of the time intervals has to be more than the coherence time of the channel. Also, time diversity can be achieved by means of channel coding. The idea is to transmit the different parts of the codeword corresponding to a particular symbol using different time intervals. The most practical channel codes discussed in the literature include block codes, convolutional codes and trellis-coded modulation (Duman and Ghrayeb, 2007).

Spatial diversity is achieved by the use of multiple antennas or nodes at either end or at both ends of the MIMO communication link. The separation between the antennas or nodes has to be more than half a wavelength in a uniform scattering environment. Systems with multiple antennas are also referred to as MIMO systems (Duman and Ghrayeb, 2007). Therefore we can refer to systems with multiple nodes as cooperative MIMO systems. Spatial diversity gains increase channel capacity which leads to higher data throughputs and significant improvement in data transmission reliability. These advantages are achieved without any expansion of bandwidth or higher transmit power which makes this technique very suitable to be implemented in energy constrained WSNs.

Diversity techniques can be combined to achieve greater improvements in reliability and achievable transmission rates. Perhaps the most popular combination technique is between space diversity and time diversity by using channel coding. The combination yields the space-time coding (STC) scheme. The variants of the STC scheme depend on the channel coding being used. For example, space-time block coding (STBC) schemes are based on block coding and space-time trellis coding scheme (STTC) schemes are based on trellis-coded modulation.

Multiple antennas or nodes can be exploited in different ways at both ends of the MIMO communication link. Early work in this area concerned designs of multiple antennas at the receiver side to achieve receive spatial diversity in order to boost link reliability as the number of receiving antennas grows. Among the earliest users of receive spatial diversity schemes are mobile communications systems to improve uplink performance by implementing multiple receive antennas at the base station (Proakis, 2001). If only a single transmit antenna and multiple receive antennas are used, the resulting system is referred to as a Single-Input Multiple-Output (SIMO) system.

In later work transmit spatial diversity was achieved by exploiting multiple transmit antennas with proper coding or weighting of the transmitted data signals. It is important to note that both spatial diversity schemes achieve improved transmission reliability at the cost of transmission rates comparable to the Single-Input Single-Output (SISO) systems. Clearly the achievement of higher link reliability is a trade-off with transmission rates. When multiple transmit antennas and single receive antenna are used, the resulting system is referred to as a Multiple-Input Single-Output (MISO) system.

Further research to achieve higher transmission rates and higher capacity has been done using multiple antennas at both ends of the communications link. These multiple transmit antennas and multiple receive antenna systems are referred to as MIMO systems. One of the common techniques to boost the transmission rates is to provide the receivers with independent streams of the same data signal from different transmit antennas. In this way, the transmit antennas are exploited to boost the transmission rates at the cost of lower link reliability. However, when operating under certain constraints, the same scheme can achieve full diversity gain leading to higher link reliability.

A comparison between the different spatial diversity schemes discussed above is shown in Table 1 where M and N denote the number of transmit antennas and receive antennas, respectively.

Scheme	M	N	Example	Benefits
SISO	1	1	No transmit or receive diversity	No diversity gain.
SIMO	1	> 1	Receive diversity	Diversity proportional to N .
MISO	> 1	1	Transmit diversity	Diversity proportional to M .
MIMO	> 1	> 1	Use of multiple antennas at both the transmitter and receiver	Diversity proportional to the product of M and N . Array gain (coherent combining assuming prior channel estimation).

Table 1. Comparison of main spatial diversity schemes

4. Multiple Nodes in Wireless Sensor Networks

A major design requirement of WSNs is to reduce the total energy consumption of the sensor nodes. The transmission power can be reduced by providing the highest diversity gain possible which leads to higher link reliability and thus lower the retransmission rates. Therefore the exploitation of multiple nodes in WSNs (referred to as cooperative MIMO) is inevitable in order to provide higher reliability communication link and reduce transmission power.

Most of the previous work in the area of cooperative MIMO has assumed that the cooperating sensor nodes are perfectly synchronised during transmission and reception (Jagannathan et. al., 2004). Recently, the impact of imperfect synchronisation effects on the performance of cooperative MIMO operation in WSNs has gained more attention (Li, 2004; Li et. al., 2004; Li and Hwu, 2006). Imperfect synchronisation could occur due to the lack of carrier synchronisation or because of imperfect timing in frame and bit level synchronisation. In this chapter, we consider the impact of imperfect synchronisation caused by clock jitter alone. Each cooperating transmit node from a set of M cooperative nodes experiences clock jitter with the jitter around a reference clock, T_o denoted as T_j^m where $1 \leq m \leq M$. The detailed system model of clock jitter will be explained in Section 5.

The following discussion explains in detail the three major MIMO schemes in both synchronous and asynchronous scenarios and their practicality in WSNs. Synchronous operation assumes perfect synchronisation between cooperating transmitting nodes and asynchronous operation refers to scenarios where imperfect synchronisation occurs. The three MIMO schemes are:

- a) SIMO System
- b) MISO System
- c) Spatial Multiplexing MIMO System

4.1 SIMO System

Perhaps the first technique in diversity particularly related to spatial utilisation is the receive diversity (SIMO) technique. The transmitter can choose to perform frequency, time, or polarisation due to the fact that the source of diversity does not affect the method of combination at the receiver side (with the exception of transmit spatial diversity (Jafarkhani, 2005). At the receiver side, more than one antenna or node must be used, $N \geq 2$, to gain spatial diversity which leads to higher reliability by increasing the average signal-to-noise ratio (SNR) and lowering the bit error rate (BER).

There are four popular combining methods that are utilised at the receiver: Maximum Ratio Combining (MRC), Equal Gain Combining (EGC), Selection Combining (SC) and Switched Combining (Simon and Alouini, 2000; Rappaport, 2002; Jafarkhani, 2005; Duman and Ghrayeb, 2007). MRC achieves diversity gain equal to the number of the receive antennas, N , with N Radio Frequency (RF) chains as shown in Figure 1. EGC is a special case of MRC with equal weights' amplitudes where all the received signals are co-phased and then combined together with equal gain. The EGC receiver's circuit is less complex but at the cost of lower diversity gain than for MRC.

Assume that the receiver receives N replicas of the transmitted signal, s through N independent paths. The k^{th} received signal is defined by:

$$r_k = h_k s + \eta_k \quad (1)$$

where $k = 1, 2, \dots, N$, η_k is the complex white Gaussian noise sample vector added to the k^{th} copy of the signal with zero mean and σ^2 variance, $\eta_k \sim N_c(0, \sigma^2)$ and h_k is the complex channel fading gain vector with zero mean and ρ^2 variance, $h_k \sim N_c(0, \rho^2)$. We assume that the receiver is coherent where the channel information is known and perfectly estimated at the receiver. If the average power of the transmitted symbol is $E[|s|^2]$, the instantaneous SNR of the k^{th} receiver is given by (Jafarkhani, 2005):

$$\gamma_k = |h_k|^2 \cdot \frac{E[|s|^2]}{\sigma^2}. \quad (2)$$

The attempt to recover s can be given by the following MRC linear combination:

$$\tilde{s} = \sum_{k=1}^N h_k^* r_k = \sum_{k=1}^N |h_k|^2 s + \sum_{k=1}^N \eta_k h_k^* \quad (3)$$

where \tilde{S} is the resulting decision variable with S mean and $\frac{\sigma^2}{\sum_{k=1}^N |h_k|^2}$ variance which can

be represented as $\tilde{S} \sim \left(S, \frac{\sigma^2}{\sum_{k=1}^N |h_k|^2} \right)$. The resulting effective SNR at the output of the MRC block is proportional to $\sum_{k=1}^N |h_k|^2$ and given as:

$$\gamma = \sum_{k=1}^N |h_k|^2 \cdot \frac{E[|S|^2]}{\sigma^2} = \sum_{k=1}^N \gamma_k. \quad (4)$$

From Equation (4), the effective SNR of the system with a receive diversity scheme is equivalent to the sum of the instantaneous receive SNRs for N different paths. If we assume that all the different paths have the same average SNR, then the average of the effective SNR at the output of the MRC block is:

$$\bar{\gamma} = \sum_{k=1}^N E[|h_k|^2] \cdot \frac{E[|S|^2]}{\sigma^2} = \sum_{k=1}^N E[\gamma_k] = N \cdot \bar{\gamma}_k. \quad (5)$$

By increasing the number of receiving antennas N , the receive average SNR can be increased by N -fold which leads to the lowest possible BER for the system such that at the high SNRs regime, the error probability decays as SNR_a^{-N} (Proakis, 2001). On the other hand, when N increases, the receiver becomes more complex and larger in size. It seems that we have to trade off the cost, size and complexity of the devices or nodes for higher link reliability. Selection combining was introduced to reduce the N^{th} RF chains complexity with only one RF chain used where the receiver performs signal selection with the highest SNR for decoding as shown in Figure 2. Also, channel state information is not needed which means that selection combining can be used for both coherent and non-coherent receivers (Simon and Alouni, 2000). The average SNR at the output of the selection combiner is given as:

$$\bar{\gamma} = \bar{\gamma}_k \sum_{k=1}^N \frac{1}{k}. \quad (6)$$

As can be seen from Equation (6), selection combining does not achieve the full N diversity gain which clearly trades off the diversity gain for lower complexity.

Later, a hybrid selection/MRC technique was proposed to balance the requirements between higher diversity gain and lower complexity (Jafarkhani, 2005).

Switched combining employs scanning and selection operation where the receiver scans all the diversity branches and selects a particular branch with the SNR above a certain predetermined threshold (Jafarkhani, 2005). The signals from the selected branch are selected as the output until its SNR drops below the threshold. Then the receiver starts to scan again and switches to another branch. This scheme is simpler since it does not require any channel knowledge but at the cost of lower achievable diversity gain.

In the context of practicality in WSNs, a SIMO with MRC scheme is more practical and promising for implementation as shown in Figure 3. This is due to the fact that each node in the network represents a single path processing including the RF chain processing. It seems that the complexity issue in the traditional SIMO approach can be reduced with the cooperative SIMO implementation while providing the highest SNR possible. Moreover, the transmission by the transmit node can be done without the need for time synchronisation, thus the cooperative SIMO system is not affected by clock jitter.

On the other hand, there are other issues that we have to consider such as the fact that data signals received by all the receiving nodes must be forwarded to a common destination node in order to combine and decode them successfully. Moreover, the diversity gain does not contribute to the reduction of the total transmission power and the use of N receiving nodes can contribute to the higher circuit power in the network.

4.2 MISO System

The main motivation for using of multiple antennas at the transmitter is to reduce the required processing power and complexity at the receiver which leads to lower power consumption, lower size and lower cost. However, the MISO concept is not easy to exploit and to implement (Naquib and Calderbank, 2000). Additional signal processing is required at both the transmitters and receiver in order to correctly decode the received signals. Also, another challenge is that the transmitter does not know the channel conditions unless channel information is fed back by the receiver to the transmitter (Liu et. al., 2001).

A number of MISO schemes have been proposed in the literature and can be categorised into two major classes:

- a) Closed-loop MISO schemes with feedback
- b) Open-loop MISO schemes without feedback

The difference between the two types of schemes is that the former relies on channel state information which has to be fed back to the transmitter and the latter eliminate the need for channel state information at the transmitter.

4.2.1 Closed-loop MISO System

The modulated signals are weighted with different weighting factors and transmitted with multiple antennas M at the transmitter. The weighting factors are chosen with the assistance of the channel state information so that the received SNR can be maximised at the receiver. The weighting factors must be optimised in order to achieve full diversity gain. One of the drawbacks of this system is that when the weighting factors are not optimised due to imperfect channel estimation, the received SNR is decreased.

Two of the most popular closed-loop MISO schemes are switched diversity (Winters, 1983) and digital beamforming (Litva and Lo, 1996). Among the two schemes, the best solution, if the transmitter has perfect knowledge of the channel, is the MISO beamforming scheme. The MISO beamforming scheme is less complex and easier to deploy which makes it more practical to implement in WSNs.

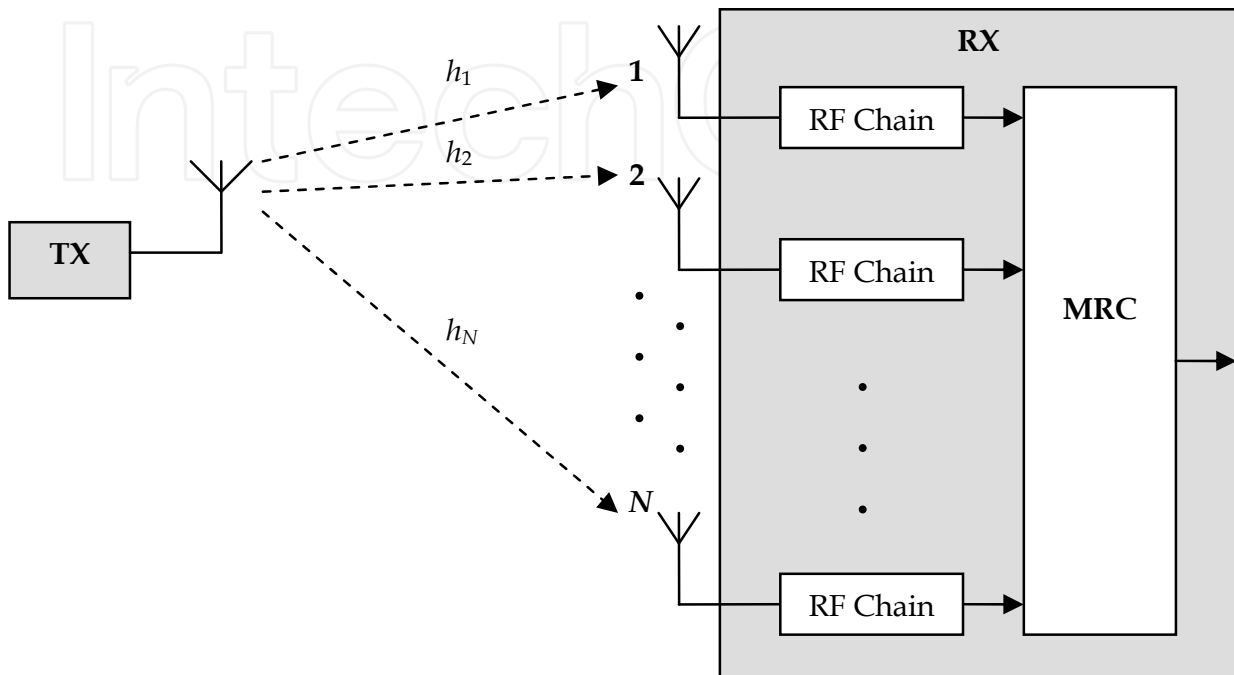

Fig. 1. A system with one transmit antenna and N receive antennas with MRC.

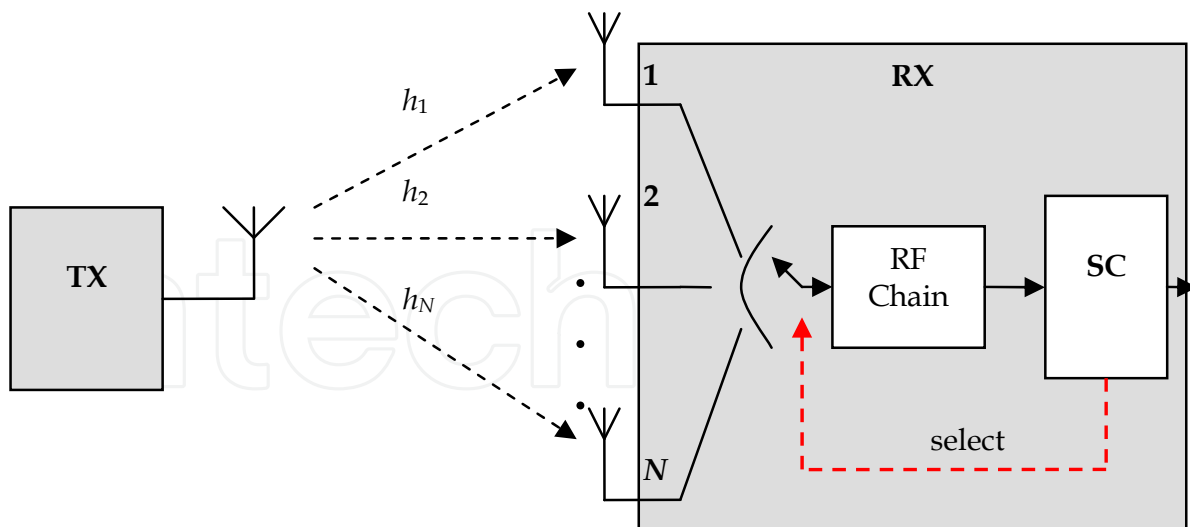

Fig. 2. A system with one transmit antenna and N receive antennas with SC.

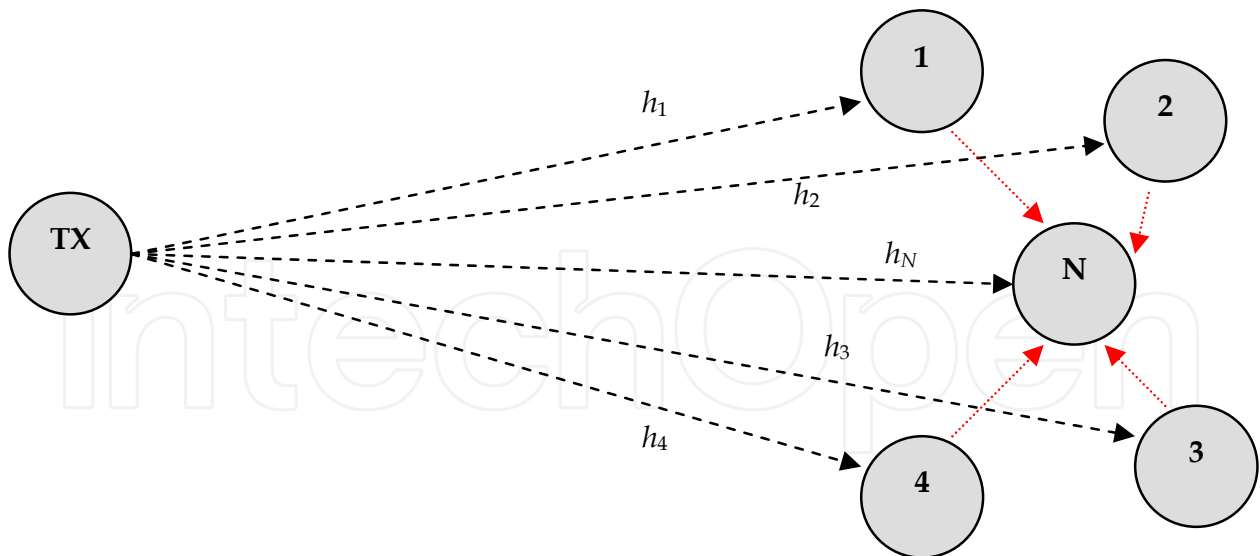

Fig. 3. A cooperative receive diversity system with one transmit node and N receive nodes.

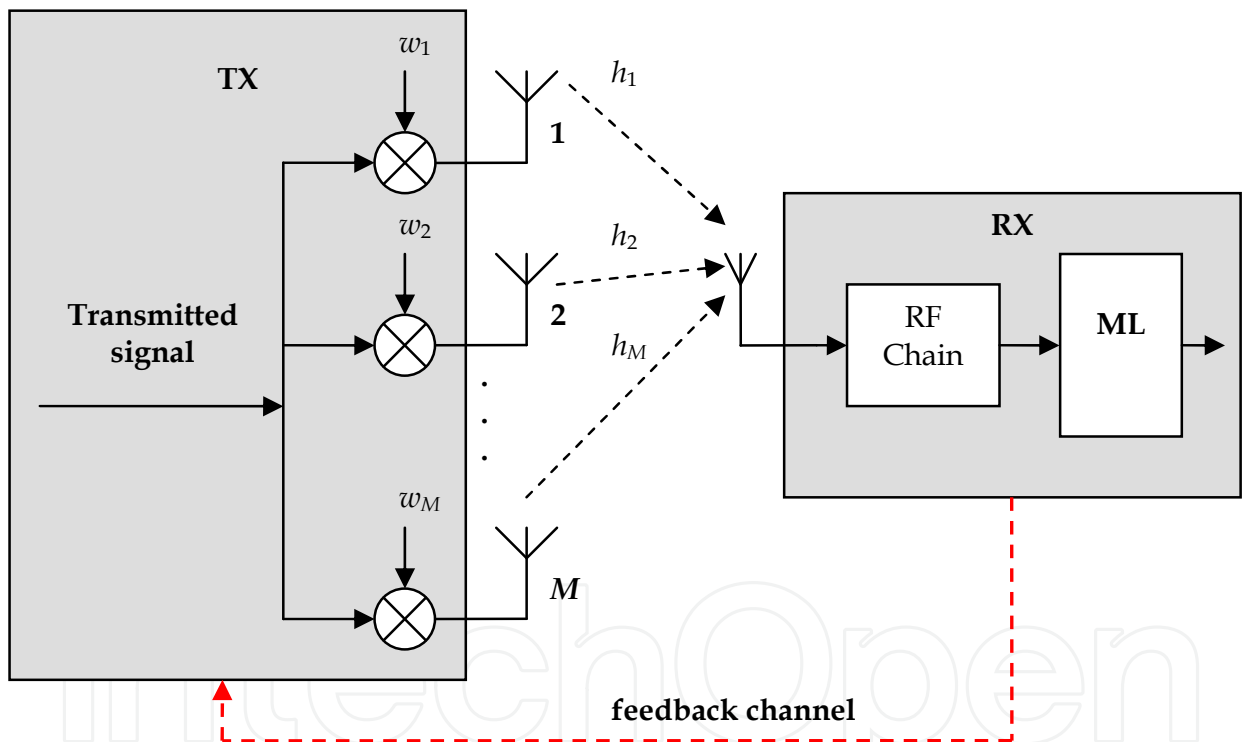

Fig. 4. A beamforming transmit diversity system with M transmit antennas and 1 receive antenna.

Let us consider a digital MISO beamforming system with M antennas at the transmitter and one antenna at the receiver as shown in Figure 4. The transmitter transmits M weighted transmitted signals, w_k 's through M independent paths. The received signal is then given as:

$$r = \sum_{k=1}^M h_k w_k s + \eta \tag{7}$$

where $k = 1, 2, \dots, M$, η is the complex white Gaussian noise sample added to the received signal with zero mean and σ^2 variance, $\eta \sim N_c(0, \sigma^2)$ and h_k is the complex channel fading gain vector with zero mean and ρ^2 variance, $h_k \sim N_c(0, \rho^2)$. We assume that the receiver is coherent where the channel information is known and perfectly estimated at the receiver. The decision variable \tilde{S} for the Maximum Likelihood (ML) detector has S mean and

$\frac{\sigma^2}{\sum_{k=1}^M h_k w_k}$ variance. If the average power of the transmitted symbol is $E[|s|^2]$, the instantaneous effective SNR is then given as:

$$\gamma = \sum_{k=1}^M h_k w_k \cdot \frac{E[|s|^2]}{\sigma^2}. \quad (8)$$

Given the transmitter knows the channel perfectly through feedback from the receiver, the weights are scaled and optimised proportionally to h_k^* so as to maximise the SNR in \hat{S} . The resulting instantaneous SNR is proportional to $\sum_{k=1}^M |h_k|^2$ and given as:

$$\gamma = \sum_{k=1}^M |h_k|^2 \cdot \frac{E[|s|^2]}{\sigma^2}. \quad (9)$$

Let $\gamma_k = |h_k|^2 \cdot \frac{E[|s|^2]}{\sigma^2}$, then the effective receive SNR can be written as:

$$\gamma = \sum_{k=1}^M |h_k|^2 \cdot \frac{E[|s|^2]}{\sigma^2} = \sum_{k=1}^M \gamma_k. \quad (10)$$

From Equation (10), the effective SNR of the system with the transmit MISO beamforming diversity scheme is equivalent to the sum of the instantaneous receive SNRs for M different paths. If we assume that all the different paths have the same average SNR, then the average of the effective SNR at the output of the ML block is:

$$\bar{\gamma} = \sum_{k=1}^M E[|h_k|^2] \cdot \frac{E[|s|^2]}{\sigma^2} = \sum_{k=1}^M E[\gamma_k] = M \cdot \bar{\gamma}_k. \quad (11)$$

As M grows, the receive average SNR is increased by M -fold which leads to the lowest possible BER for the system. Furthermore, the total radiated power for all M antennas is the same as the total transmission power of one single transmit antenna, as in the receive diversity cases (Larsson and Stoica, 2003). It is clear that the transmission power P_t has been reduced down to P_t/M as the diversity gain increases up to M .

In the context of practicality in WSNs, the main obstacle for MISO beamforming implementation is the issue of how to provide each transmitting node with the knowledge of the channel. A multi-channel approach can be used where one channel is dedicated for the feedback and the other channel for data transmission. The channel is estimated periodically through training sequences on the feedback channel. However, a multi-channel approach is not practical for WSNs because such an approach increases the hardware and processing complexity at both the transmitter and the receiver. Also, such an approach requires tight frequency synchronisation to maintain the dual channel utilisation which obviously increases the total energy consumption of the network.

A better and practical alternative approach is to exploit the existing control protocols in WSNs such as those utilising RTS-CTS packets to provide the channel state information to the transmitter as shown in Figure 5. Both the control and data communications can be maintained over a single-channel with less complexity and loose synchronisation.

Moreover, the transmission power of each transmitting node is reduced down to P_t/M which leads to the reduction of the total power consumption in the network. In addition, the RTS-CTS implementation can also reduce the hidden node problem in such densely distributed sensor networks.

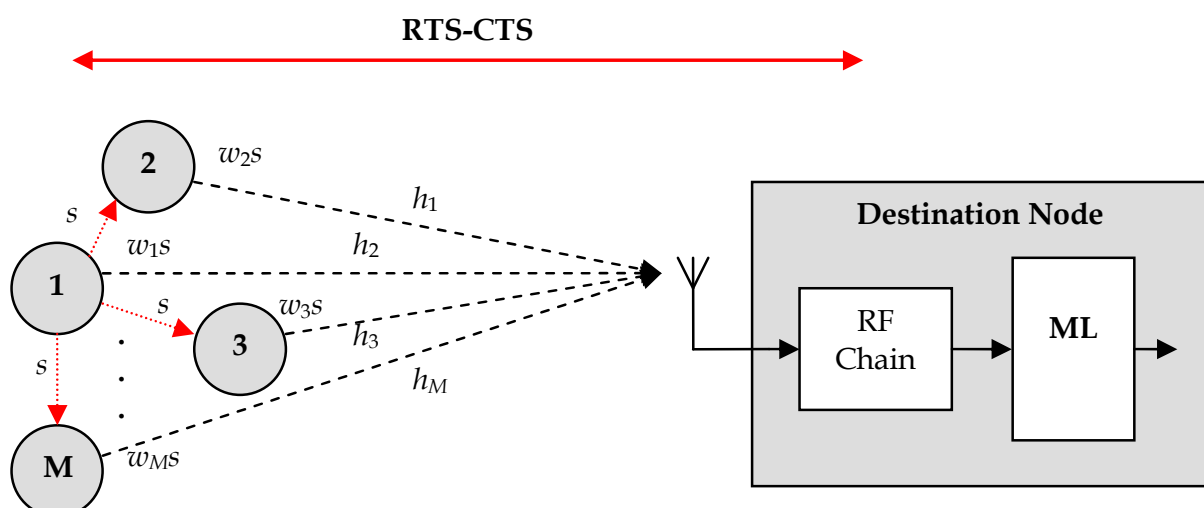

Fig. 5. A cooperative beamforming transmit diversity system with M transmit nodes and 1 destination.

4.2.2 Open-loop MISO System

The modulated signals must be processed at the transmitter first before being transmitted from multiple antennas M . The main motivation is to reduce the complexity of the feedback schemes in the closed-loop MISO systems. The transmitter design is enhanced with more advanced signal processing and/or a combination of various diversity techniques in order to provide the receiver with the capability to exploit full diversity gain from the received signals.

One of the early proposed open-loop MISO schemes is the antenna hopping scheme (Seshadri and Winters, 1993; Wittneben, 1991). The modulated signals are transmitted from M antennas with different time intervals. At the receiver, the delayed signals introduce a multipath-like distortion for the intended signal.

The multipath-like distortion can be resolved at the receiver by using a ML detector or a Minimum Mean Square Error (MMSE) detector to obtain M diversity gain. The antenna hopping scheme has been shown to achieve fully diversity gain up to M without any bandwidth expansion but at the cost of a lower spatial rate.

In order to gain the full spatial rate, the diversity gain achieved from a multiple antennas implementation is combined with the coding gain achieved from the error control and channel coding schemes. The combination schemes of error control coding and multiple antennas have gained the full spatial rate in addition to the diversity benefit but at the cost of bandwidth losses due to code redundancy (Vucetic and Yuan, 2003). A better and practical approach is a joint design of multiple antennas with channel coding schemes. This approach can be achieved when the multiple antennas and channel coding schemes are designed as a single signal processing module. Coding techniques for multiple antenna communications are called space-time coding (STC). STC schemes provide redundant transmission in both spatial and temporal domains. In addition to the diversity gain, full spatial rate and no bandwidth expansion advantages, STC schemes can be combined with multiple receive antennas to achieve capacity gain.

The most popular STC scheme is due to Alamouti (Alamouti, 1998) who studied the case of two transmit antennas. The Alamouti space-time encoder picks up two symbols s_1 and s_2 from an arbitrary constellation and the two symbols are transmitted in two consecutive time slots as shown in Figure 6. In the first time slot, s_1 is transmitted from the first antenna while s_2 is transmitted from the second antenna. Consecutively in the second time slot, $-s_2^*$ is transmitted from the first antenna while s_1^* is transmitted from the second antenna. Since both the symbols are transmitted in two time slots, the overall rate is given as one symbol per channel use. The key concept of the Alamouti STC scheme is the orthogonal design of the transmit sequences. The inner product of the sequences x_1 and x_2 is given as:

$$x_1 \cdot x_2 = s_1 s_2^* - s_1^* s_2 = 0. \quad (12)$$

The transmitted code matrix has the following property:

$$X \cdot X^H = \begin{bmatrix} s_1 & -s_2^* \\ s_2 & s_1^* \end{bmatrix} \cdot \begin{bmatrix} s_1^* & s_2^* \\ -s_2 & s_1 \end{bmatrix} = \begin{bmatrix} |s_1|^2 + |s_2|^2 & 0 \\ 0 & |s_1|^2 + |s_2|^2 \end{bmatrix}. \quad (13)$$

Assume that both the paths experience quasi-static fading where the fading coefficients are constant across the two consecutive symbol transmission intervals which can be expressed as:

$$\begin{aligned} h_1(t) &= h_1(t+T) = h_1 = |h_1| e^{j\theta_1} \\ h_2(t) &= h_2(t+T) = h_2 = |h_2| e^{j\theta_2} \end{aligned} \quad (14)$$

where $|h_k|$ and θ_k , $k = 1, 2$, are the amplitude gain and phase shift for the path from transmit antenna k to the receiver antenna and T is the symbol duration. The received signal in the first time slot is given as:

$$r(t) = r_1 = h_1 s_1 + h_2 s_2 + \eta_1 \quad (15)$$

and in the second time slot, the received signal is given as:

$$r(t+T) = r_2 = -h_1 s_2^* + h_2 s_1^* + \eta_2 \quad (16)$$

where η_1 and η_2 are the complex white noise with zero mean and variance σ^2 for the first time slot and second time slot, respectively. The received signal vector is defined at the receiver as:

$$r = \begin{bmatrix} r_1 \\ r_2^* \end{bmatrix} \quad (17)$$

which can be written as:

$$r = \begin{bmatrix} h_1 & h_2 \\ h_2^* & -h_1^* \end{bmatrix} \begin{bmatrix} s_1 \\ s_2 \end{bmatrix} + \begin{bmatrix} \eta_1 \\ \eta_2^* \end{bmatrix}. \quad (18)$$

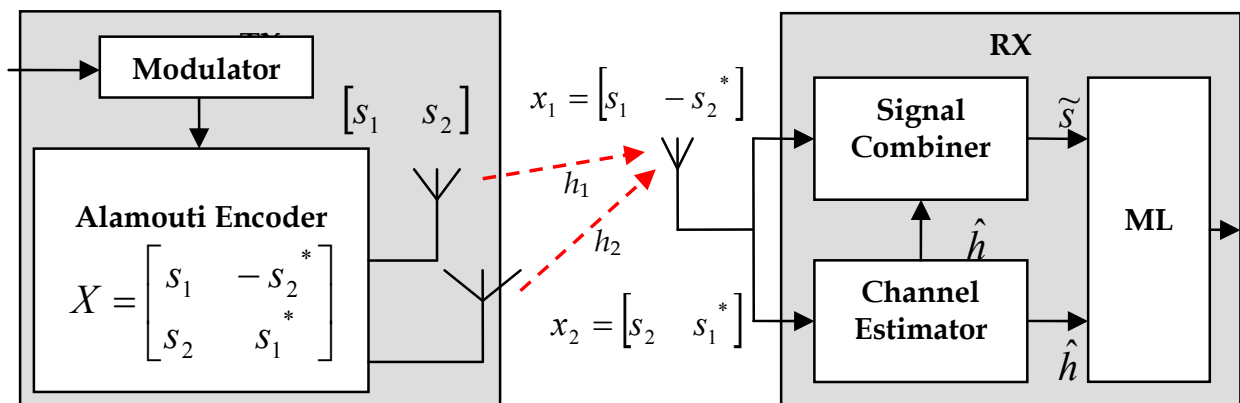

Fig. 6. An alamouti STC transmit diversity system with 2 transmit antennas and 1 receive antenna.

Assume that the receiver is coherent and optimal. Then the attempt to recover s_1 and s_2 can be given by the following linear combination:

$$\tilde{s} = \begin{bmatrix} h_1 & h_2 \\ h_2^* & -h_1^* \end{bmatrix}^H \begin{bmatrix} r_1 \\ r_2^* \end{bmatrix} = \begin{bmatrix} \sum_{k=1}^M |h_k|^2 s_1 + h_1^* \eta_1 + h_2 \eta_2^* \\ \sum_{k=1}^M |h_k|^2 s_2 + h_2^* \eta_1 - h_1 \eta_2^* \end{bmatrix}. \quad (19)$$

The resulting decision variables in Equation (19) are equivalent to the one obtained with receive diversity using the MRC scheme. The only difference is the phase rotations on the noise components which do not degrade the effective SNR (Alamouti, 1998).

The decision variable vector $\tilde{\mathbf{s}}$ with S mean and $\frac{\sigma^2}{\sum_{k=1}^M h_k}$ variance is sent to the ML detector. If the average power of the transmitted symbols is $E[|s_n|^2]$, the receive SNR in each sub-channel is given as:

$$\gamma = \sum_{k=1}^M h_k \cdot \frac{E[|s_n|^2]}{2\sigma^2}. \quad (20)$$

We can observe from Equation (20) that the linear processing in Equation (19) transforms the space-time channel into two parallel and independent scalar channels. If we assume that the symbols are Phase Shift Keying (PSK) modulated signals with equal energy constellations, the total transmission power is effectively doubled as shown in Equation (20) compared to the SIMO MRC and MISO beamforming schemes. Let $\gamma_k = |h_k|^2 \cdot \frac{E[|s_n|^2]}{2\sigma^2}$, then the effective receive SNR can be written as:

$$\gamma = \sum_{k=1}^M |h_k|^2 \cdot \frac{E[|s_n|^2]}{2\sigma^2} = \sum_{k=1}^M \gamma_k. \quad (21)$$

If we assume that all the different paths have the same average SNR, then the average of the effective SNR at the output of the ML block is:

$$\bar{\gamma} = \sum_{k=1}^M E[|h_k|^2] \cdot \frac{E[|s_n|^2]}{2\sigma^2} = \sum_{k=1}^M E[\gamma_k] = M \cdot \bar{\gamma}_k. \quad (22)$$

As we can observe, the MISO Alamouti STC scheme provides the same diversity gain as the SIMO MRC and MISO beamforming schemes with M equal to two but with 3 dB loss in error performance (Larsson and Stoica, 2003). In addition, the MISO Alamouti STC scheme can be applied for a system with 2 transmitting antennas and N receiving antennas to gain higher capacity. Although such systems are very important for high-speed networks, careful consideration of circuit and processing energies and decoder complexity at the receiver in WSNs keeps our discussion to systems with only one receive antenna which corresponds to one receive node in cooperative MISO transmission.

The Alamouti STC scheme can be generalised from two transmit antennas up to M transmit antennas by using the same theory of orthogonal design (Tarokh et. al., 1999). The generalised scheme is referred to as Orthogonal Space-Time Block Codes (OSTBC). In general, OSTBC can be categorised into two types: real and complex, based on the signal constellation.

The basic operation of OSTBC is shown in Figure 7 where the scheme can achieve full transmit diversity up to M order with M transmit antennas while allowing the use of a very simple ML decoding algorithm and linear combining at the receiver. However, OSTBC trades off full diversity gain for lower spatial rate when $M > 2$. In order to provide a compromise between full diversity and full rate, a Quasi-Orthogonal STBC (Quasi OSTBC) scheme was proposed in (Jafarkhani, 2005).

Another class of STCs is the Space-Time Trellis Codes (STTC) (Tarokh et. al., 1998). STTC achieves higher coding gain and is comparable to STBC in terms of achieving full transmit diversity gain. However, the encoder design based on trellis-coded modulation leads to a more complex receiver with a Viterbi algorithm decoding implementation. The ML decoder complexity grows exponentially with the number of bits per symbol, thus limiting the achievable data rates.

In the context of practicality in WSNs, the main obstacle of MISO STBCs and STTCs schemes implementation is the issues of how to provide each transmitting node with the transmit sequences knowledge and how different transmit sequences are assigned to each node in order to provide an orthogonal or quasi-orthogonal design.

A better and practical approach as suggested in (Yang et. al., 2007) is when the source node broadcasts the transmit sequences to its particular neighbours in order to provide the transmit sequences knowledge together with the original data signal. Such an approach introduces an increasing packet overhead as M increases, prior data packet transmission. The overhead is a compromise with full diversity gain which achieves higher reliability and lower transmission energy.

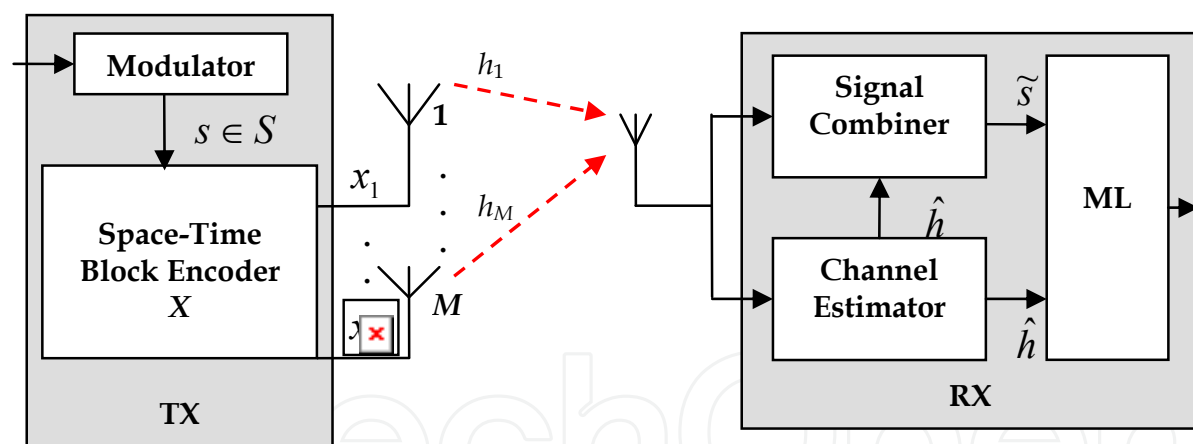

Fig. 7. A STBCs transmit diversity system with M transmit antennas and 1 receive antenna.

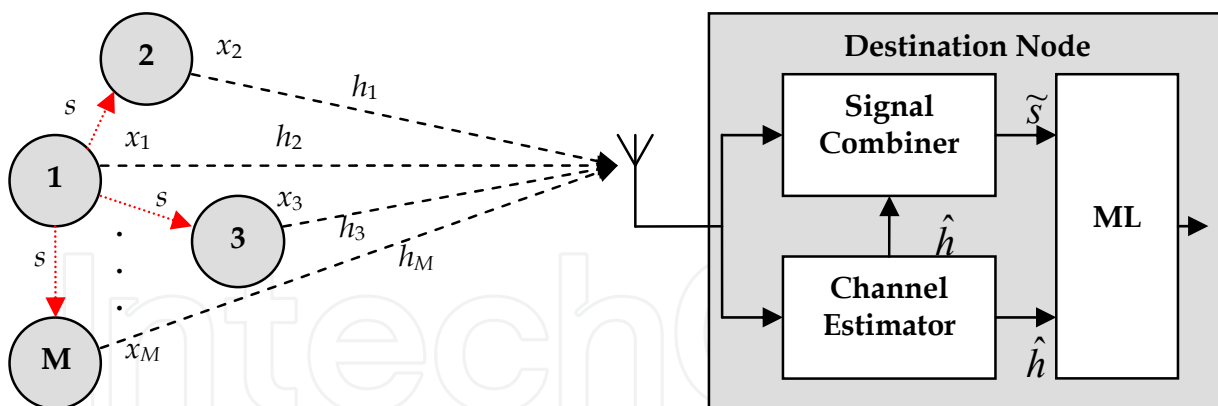

Fig. 8. A cooperative STBC transmit diversity system with M transmit nodes and 1 destination.

As a comparison, MISO STBC is more practical and promising to be implemented in WSNs due to a simpler decoding algorithm which leads to lower processing energy at the receiver. On the other hand, the simpler encoding and decoding algorithms of MISO STBC come at the cost of higher transmission power compared to the MISO beamforming scheme. The pictorial concept of cooperative MISO STBC is shown in Figure 8.

4.2.3 Spatial Multiplexing MIMO System

The main motivation of spatial multiplexing (SM) scheme is to achieve a higher data rate while maintaining the same full diversity gain. Thus the main purpose of SM schemes is basically to complement the lack of spatial rate in MISO STBC and STTC schemes. Therefore SM schemes are designed purposely for high data rate applications such as mobile communications systems and wireless local area networks. Though the current WSNs target only low to medium data rate applications, future generations of WSNs may require to operate with such high data rate applications which makes the investigation of cooperative SM in WSNs relevant and useful.

The main concept of SM (also referred as Layered Space-Time Codes - LSTC (Foschini, 1996)) is to provide simultaneous transmissions of M information streams in the same frequency band from M transmit antennas. However, by using such a transmission method, a constraint is introduced where the number of receive antennas must be equal or greater than the number of transmit antennas ($N \geq M$) in order to separate and detect the M transmitted signals. The separation process involves a combination of interference suppression and cancellation. The achievable spatial rate is given as $R_c b M$ where R_c denotes the rate of the channel code whenever channel coding is employed and 2^b is the signal constellation size. When full channel code is achieved with $R_c = 1$ and Binary PSK is used with $b = 1$, we can show that the spatial rate is increased linearly with M .

Among the simplest SM schemes is Bell Laboratories Layered Space-Time (BLAST) (Golden et. al., 1999). There are various versions of the BLAST schemes in the literature such as Vertical BLAST (VBLAST), Horizontal BLAST (HBLAST) and Diagonal BLAST (DBLAST). The simplest version is VBLAST due to the simplest encoder architecture compared to HBLAST and DBLAST (Vucetic and Yuan, 2003). VBLAST is also referred to as an un-coded LST scheme while HBLAST and DBLAST are classified as coded LST schemes. The simple encoder architecture makes VBLAST the most practical version of SM schemes for

implementation in WSNs in order to keep the complexity and power consumption as low as possible. There are other SM schemes such as threaded LSTCs and multilayered LSTCs, with higher spatial rate but they come at the cost of more complex encoding and decoding mechanisms. Obviously these schemes are not practical to be implemented in WSNs and thus are not considered in our work.

A VBLAST encoder is shown in Figure 9. As shown in the figure, the bit stream is demultiplexed into M sub-streams. Each M sub-stream is then modulated and transmitted from M transmit antennas. The transmitted signal matrix is given as:

$$X = \begin{bmatrix} s_k^t \end{bmatrix} \quad (23)$$

where $k = 1, 2, \dots, M$ and $t = 1, 2, \dots, L$ with L is the transmission block length. At a given time t , the transmitter transmits the t^{th} column from the transmission matrix, one symbol from each k^{th} antenna. The given transmission mechanism represents vertical structuring referring to transmission sequences of the matrix columns in the space-time domains (Vucetic and Yuan, 2003). Given the system constraint of $N \geq M$, the achievable spatial rate is bM and the achievable spatial diversity depends on the detection scheme employed at the receiver. When a Zero Forcing (ZF) or a Minimum Mean Square Error (MMSE) decoder is used at the receiver for the separation and detection, the achievable spatial diversity varies between 1 to N (Vucetic and Yuan, 2003). In order to gain full spatial diversity equal to N , a ML decoder must be employed at the receiver at the cost of a more complex decoder compared to ZF and MMSE. The complexity of the ML decoder increases linearly with bN . Thus the use of a modulation scheme with the smallest constellation size (e.g. $b = 1$) is very helpful to reduce the decoder complexity while achieving higher spatial diversity gain.

In the context of practicality in WSNs, there are three major issues that must be tackled: how to provide the data packet stream to $M-1$ transmitting nodes, how to transmit each M data packet stream simultaneously from M nodes and how to forward the receive data packets by $N-1$ receiving nodes to the destination. An example of architecture for cooperative SM which is based on the VBLAST scheme was proposed in (Yang et. al., 2007) and is shown in Figure 10. The cooperative SM scheme has the following operations:

- a) Source node broadcasts the original data packet stream to its $M-1$ neighbour nodes with very low power and all the M transmitting nodes send the same data packet streams simultaneously after the sending timer expires.
- b) N receiving nodes receive the data packet streams from M transmitting nodes and each receiving node employs a ML decoder to decode the data packet and forward the data packet to the destination node.

In order to gain both spatial diversity and spatial rate, the constraint of the traditional SM scheme such as $N \geq M$ also works for the cooperative SM scheme. Consider the transmission route in Figure 10. The error rate in each route is given as:

$$P_e = P_{e_{M-1}} + P_{e_{pp(dst)}} - P_{e_{pp(dst)}} P_{e_{M-1(recv)}} \quad (24)$$

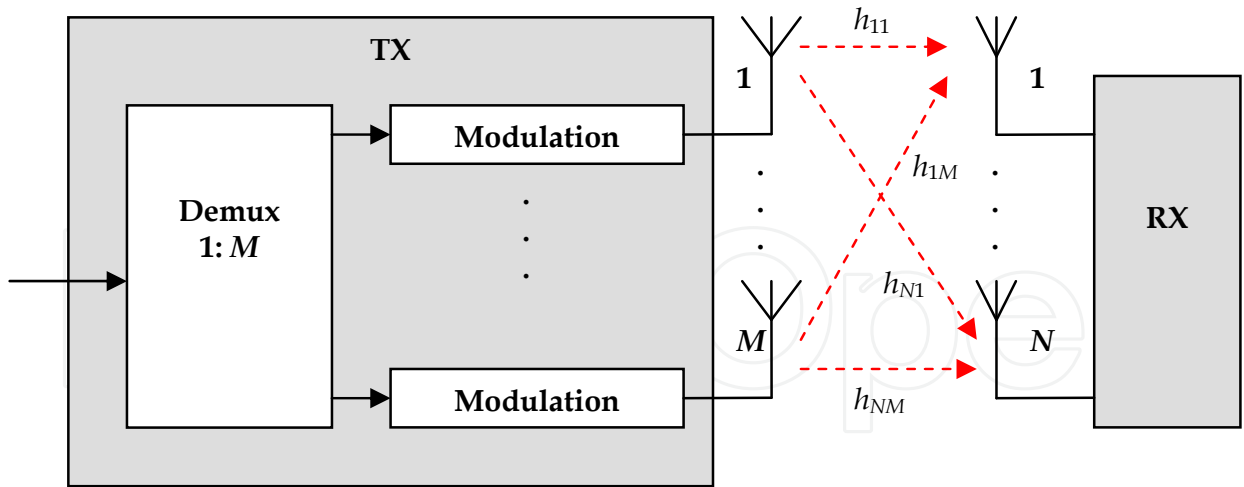

Fig. 9. A VBLAST spatial multiplexing system with M transmit antennas and N receive antennas.

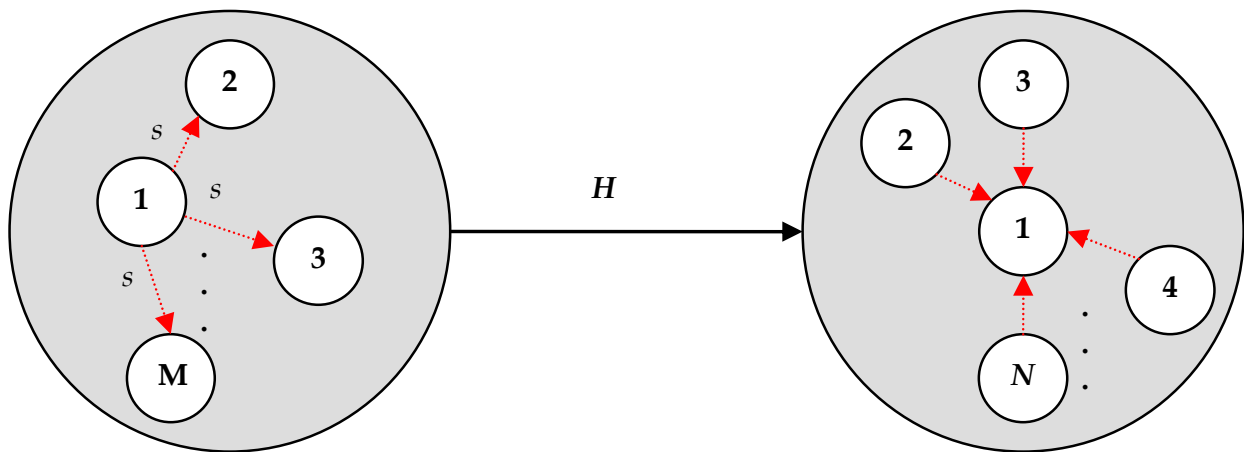

Fig. 10. A cooperative spatial multiplexing system with M transmit nodes and N receive nodes.

where P_{eM_1} is the error rate for M nodes cooperatively sending to one receiving node which relates to the power summation from multiple paths M , and different fading characteristics that may occur in different signal transmission paths. $P_{epp(dst)}$ is the error rate from one receiving node to the destination. A simple majority decision rule is employed at the destination node when multiple packets are received from $N-1$ nodes (Yang et. al., 2007). The data packet stream with the lowest BER, which means that the SNR is maximised, is selected at the destination node. If each receiving node in the receiving group has the same BER, the BER in the destination node after the reception from the N nodes forming the reception group is given as:

$$P_{eM_N} = \sum_{k=N/2}^N \binom{N}{k} P_e^k (1 - P_e)^{N-k} . \tag{25}$$

5. Performance Analysis

In this section, we study the performance of cooperative MIMO schemes discussed earlier on, namely cooperative MISO Beamforming (BF), MISO STBC and MIMO SM schemes. The clock jitter impact is modelled as a timing error function in Section 5.1. The error performance for each cooperative scheme is modelled in Section 5.2 while the results are discussed in Section 5.3.

5.1 Timing Error Modeling

We consider the impact of imperfect synchronisation which is caused by clock jitter alone. Each cooperative sending nodes experiences clock jitter with the jitter around a reference clock, T_o denoted as T_j^m where $1 \leq m \leq M$. The worst case scenario is considered here with only 2 cooperative transmitting nodes where the clock jitters are fixed at the extreme ends, $T_j^1 = -\frac{\Delta T_b}{2}$, $T_j^2 = +\frac{\Delta T_b}{2}$ where $0 \leq \Delta T_b \leq T_b$ and T_b is the bit duration. Thus the clock jitters difference is $\Delta T_j = T_j^1 - T_j^2 = \Delta T_b$. The effect of imperfect synchronisation can be modelled as a degrading function of the bit period which consequently degrades the received bit energy. Therefore the timing error as a function of the bit period and clock jitters difference is given as:

$$T_e = T_b - \Delta T_j. \quad (26)$$

5.2 Error Performance Modeling

We derive the two most important performance parameters to measure the channel condition and to evaluate the link reliability: BER and PER. Without Forward Error Correction (FEC), the relationship between Packet Error Rate (PER), P_p and BER, P_b is given by:

$$P_p = 1 - (1 - P_b)^{N_{data}} \quad (27)$$

where N_{data} is the packet length in bits. Consider the case of BPSK modulation under quasi-static Rayleigh fading with fading gain h , experiencing a square law path loss without channel codes. In the SISO system, the conditional SNR is given by (Proakis, 2001):

$$\gamma_{bSISO} = \frac{P_t |h|^2 G_t G_r}{N_o M_l \left(\frac{4\pi d}{\lambda} \right)^2} \quad (28)$$

where P_t is the transmission power, d is the distance between the sending and destination node, G_t and G_r are the transmission and reception antenna gain, λ is the carrier wave length, M_l is the link margin and N_o is single-sided thermal noise power spectral density (PSD) given as -171 dBm/Hertz.

The probability density function (PDF) of γ_{bSISO} is given by:

$$p(\gamma_{bSISO}) = \frac{1}{\bar{\gamma}_{bSISO}} \exp\left(-\frac{\gamma_{bSISO}}{\bar{\gamma}_{bSISO}}\right) \quad (29)$$

where $\bar{\gamma}_{bSISO}$ is the average SNR. Assume that $E[|h|^2] = 1$ (Larsson and Stoica, 2003), then the value of $\bar{\gamma}_{bSISO}$ is given by:

$$\bar{\gamma}_{bSISO} = \frac{P_t E[|h|^2] G_t G_r}{N_o M_l \left(\frac{4\pi d}{\lambda}\right)^2} = \frac{P_t G_t G_r}{N_o M_l \left(\frac{4\pi d}{\lambda}\right)^2}. \quad (30)$$

The average BER can be expressed as:

$$E_h[P_{bSISO}] = E_h\left[Q\left(\sqrt{2\gamma_{bSISO}}\right)\right]. \quad (31)$$

The upper bound of the average BER can be derived as (Proakis, 2001):

$$Q\left(\sqrt{2\gamma_{bSISO}}\right) = p(x \geq \sqrt{2\gamma_{bSISO}}) \leq \exp\left(-\frac{\left(\sqrt{2\gamma_{bSISO}}\right)^2}{2}\right) \quad (32)$$

$$E\left[Q\left(\sqrt{2\gamma_{bSISO}}\right)\right] \leq E\left[\exp(-\gamma_{bSISO})\right]. \quad (33)$$

The moment generating function of γ_{bSISO} is given by (Proakis, 2001):

$$\Phi(S) = E\left[\exp(\gamma_{bSISO} S)\right] = \frac{1}{S\bar{\gamma}_{bSISO}} \quad (34)$$

$$E_h[P_{bSISO}] \leq E\left[\exp(-\gamma_{bSISO})\right] = \Phi(-1) = (1 + \bar{\gamma}_{bSISO})^{-1}. \quad (35)$$

If there are M nodes in the sending group and we are comparing between optimal cooperative BF and STBC schemes, the SNRs for both schemes for perfect synchronisation scenario at the destination node can be given by:

$$\gamma_{bBF} = \sum_{k=1}^M |h_k|^2 \frac{P_t G_t G_r}{N_o M_l \left(\frac{4\pi d}{\lambda}\right)^2} = \sum_{k=1}^M \gamma_{BFk} \quad (36)$$

$$\gamma_{bSTBC} = \sum_{k=1}^M |h_k|^2 \frac{P_t G_t G_r}{M \cdot N_o M_l \left(\frac{4\pi d}{\lambda} \right)^2} = \sum_{k=1}^M \gamma_{STBCk} \quad (37)$$

and the SNRs for imperfect synchronisation scenario at the destination node can be given by:

$$\gamma_{bBF} = \sum_{k=1}^M |h_k|^2 \frac{P_t G_t G_r}{N_o M_l \left(\frac{4\pi d}{\lambda} \right)^2} \cdot \frac{T_e}{T_b} = \sum_{k=1}^M \gamma_{BFk} \quad (38)$$

$$\gamma_{bSTBC} = \sum_{k=1}^M |h_k|^2 \frac{P_t G_t G_r}{M \cdot N_o M_l \left(\frac{4\pi d}{\lambda} \right)^2} \cdot \frac{T_e}{T_b} = \sum_{k=1}^M \gamma_{STBCk} \quad (39)$$

where γ_{BFk} and γ_{STBCk} are the instantaneous SNR on the k^{th} channel.

The PDF of γ_{BFk} and γ_{STBCk} are:

$$p(\gamma_{BFk}) = \frac{1}{\bar{\gamma}_{BFk}} \exp \left(-\frac{\gamma_{BFk}}{\bar{\gamma}_{BFk}} \right) \quad (40)$$

$$p(\gamma_{STBCk}) = \frac{1}{\bar{\gamma}_{STBCk}} \exp \left(-\frac{\gamma_{STBCk}}{\bar{\gamma}_{STBCk}} \right) \quad (41)$$

Assume that $E[\|h_k\|^2] = 1$ (Larsson and Stoica, 2003), then the values of $\bar{\gamma}_{BFk}$ and $\bar{\gamma}_{STBCk}$ for perfect synchronisation scenario become:

$$\bar{\gamma}_{BFk} = \frac{P_t E[\|h_k\|^2] G_t G_r}{N_o M_l \left(\frac{4\pi d}{\lambda} \right)^2} = \frac{P_t G_t G_r}{N_o M_l \left(\frac{4\pi d}{\lambda} \right)^2} \quad (42)$$

$$\bar{\gamma}_{STBCk} = \frac{P_t E[\|h_k\|^2] G_t G_r}{M \cdot N_o M_l \left(\frac{4\pi d}{\lambda} \right)^2} = \frac{P_t G_t G_r}{M \cdot N_o M_l \left(\frac{4\pi d}{\lambda} \right)^2} \quad (43)$$

and the average SNRs for imperfect synchronisation scenario can be given by:

$$\bar{\gamma}_{BFk} = \frac{P_t E[\|h_k\|^2] G_t G_r \cdot \frac{T_e}{T_b}}{N_o M_l \left(\frac{4\pi d}{\lambda}\right)^2} = \frac{P_t G_t G_r \cdot \frac{T_e}{T_b}}{N_o M_l \left(\frac{4\pi d}{\lambda}\right)^2} \quad (44)$$

$$\bar{\gamma}_{STBCK} = \frac{P_t E[\|h_k\|^2] G_t G_r \cdot \frac{T_e}{T_b}}{M \cdot N_o M_l \left(\frac{4\pi d}{\lambda}\right)^2} = \frac{P_t G_t G_r \cdot \frac{T_e}{T_b}}{M \cdot N_o M_l \left(\frac{4\pi d}{\lambda}\right)^2} \quad (45)$$

The moment generating functions of γ_{bBF} and γ_{bSTBC} are (Proakis, 2001):

$$\Phi(S) = E[\exp(\gamma_{bBF} S)] = \prod_{k=1}^M \frac{1}{S \bar{\gamma}_{BFk}} \quad (46)$$

$$E_h[P_{bBF}] \leq E[\exp(-\gamma_{bBF})] = \Phi(-1) = (1 + \bar{\gamma}_{BFk})^{-M} \quad (47)$$

$$\Phi(S) = E[\exp(\gamma_{bSTBC} S)] = \prod_{k=1}^M \frac{1}{S \bar{\gamma}_{STBCK}} \quad (48)$$

$$E_h[P_{bSTBC}] \leq E[\exp(-\gamma_{bSTBC})] = \Phi(-1) = (1 + \bar{\gamma}_{STBCK})^{-M} \quad (49)$$

The average BER for the cooperative SM scheme in (Yang et. al., 2007) is given as:

$$P_{bSM} = \sum_{k=N/2}^N \binom{N}{k} P_e^k (1 - P_e)^{N-k} \quad (50)$$

$$P_e = E_h[P_{bMISO}] + E_h[P_{bSISO}] - E_h[P_{bSISO}] E_h[P_{bMISO}] \quad (51)$$

where P_e is the error rate in each route and N is the number of nodes forming the reception group. The average SNR of the MISO scheme in Equation (51) is the same as the average SNR of the cooperative MISO BF scheme (Yang et. al., 2007). Thus we assume that the average BER is the same for both schemes. Table 2 lists the system parameters used for evaluating BER performance of the three cooperative MIMO schemes.

5.3 Performance Results and Discussions

Figures 11, 12 and 13 show the corresponding results for perfect synchronisation scenarios. For comparison, those figures also show the BER performance of the corresponding SISO scheme. As we can see, in general, cooperative BF outperforms the other schemes except for the special case below the 10mW transmit power where cooperative SM performs better.

However, this special case may not have a significant impact due to the fact that the operating transmission power for WSNs is in the range between 25mW to 50mW (Kohvakka et. al., 2006). Also, we can observe that the diversity gain of cooperative SM depends on N and not M as shown in Figures 12 and 13. In addition, the cooperative SM achieves spatial rate equal to M .

Figures 14 and 15 show the corresponding results for imperfect synchronisation scenarios. As we can see, in general SISO outperforms other schemes above $0.8T_b$ and cooperative SM outperforms the other schemes when the diversity gain is getting higher. However, when the diversity gain of all the cooperative schemes is the same, cooperative BF outperforms the other schemes.

Symbol	Quantity
f_c	2.4 GHz
$G_t G_r$	5 dBi [5]
M_t	40 dB [5]
d	100 meters
d_m	10 meters
R_b	250 Kbps

Table 2. System parameter for ber and per modeling

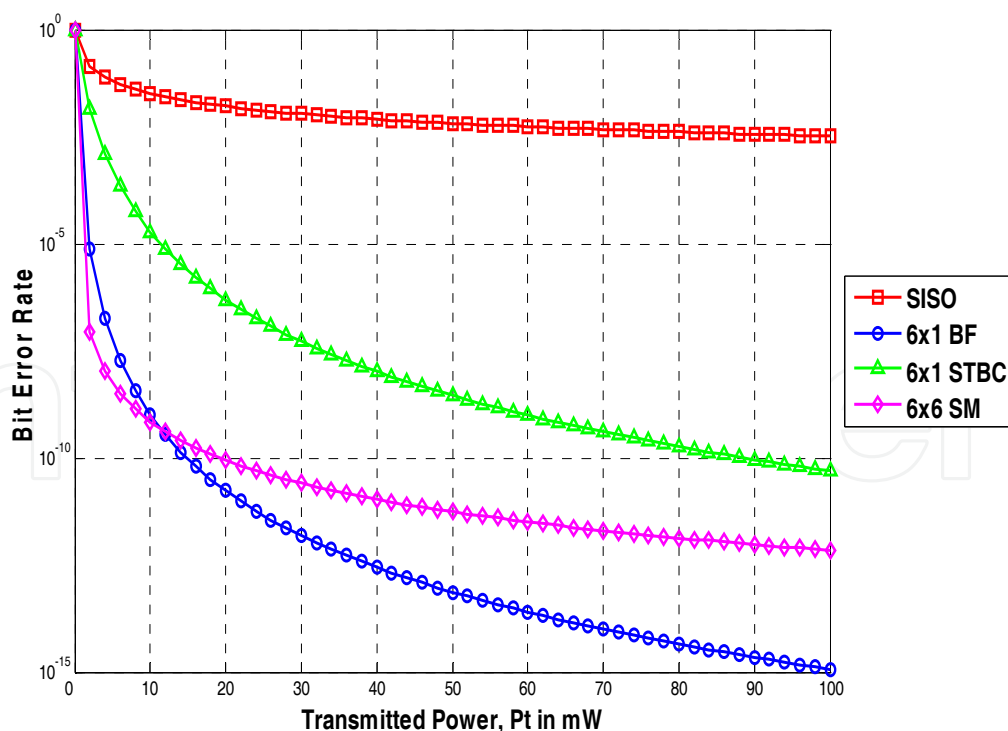

Fig. 11. BER vs. transmission power for various cooperative schemes with $M = 6$ and $N = 1$ (Cooperative BF and Cooperative STBC) and $M = N = 6$ (Cooperative SM).

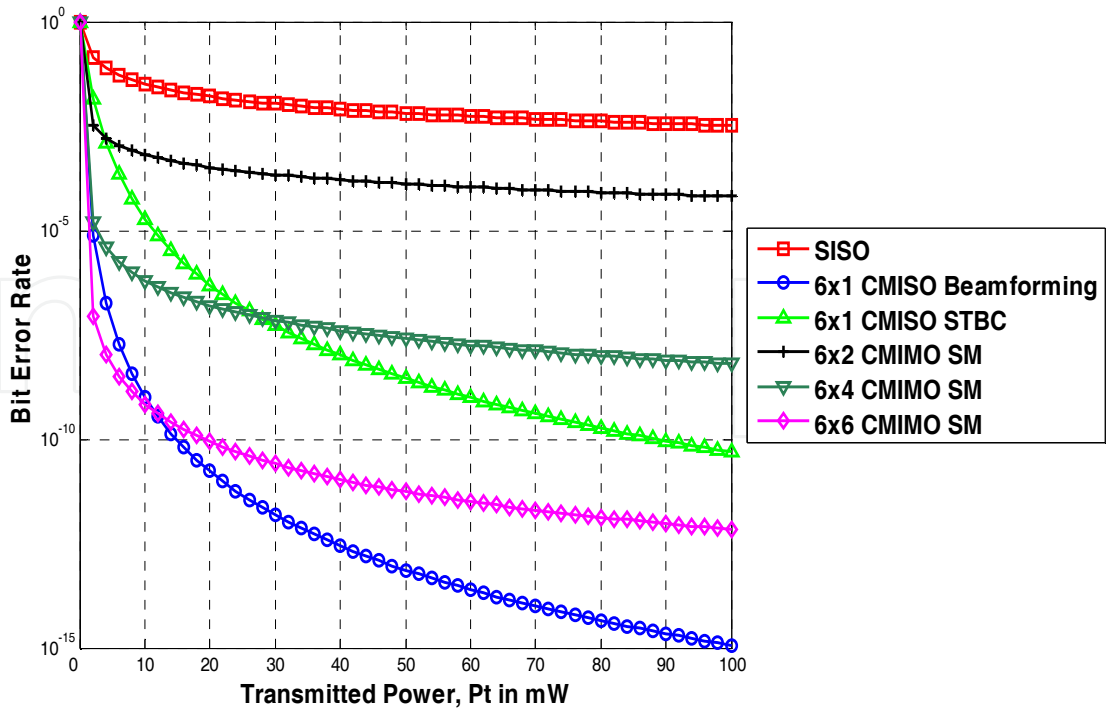

Fig. 12. BER vs. transmission power for various cooperative schemes with $M = 6$ and $N = 1$ (Cooperative BF and Cooperative STBC) and various $N = 2, 4$ and 6 for Cooperative SM with $M = 6$.

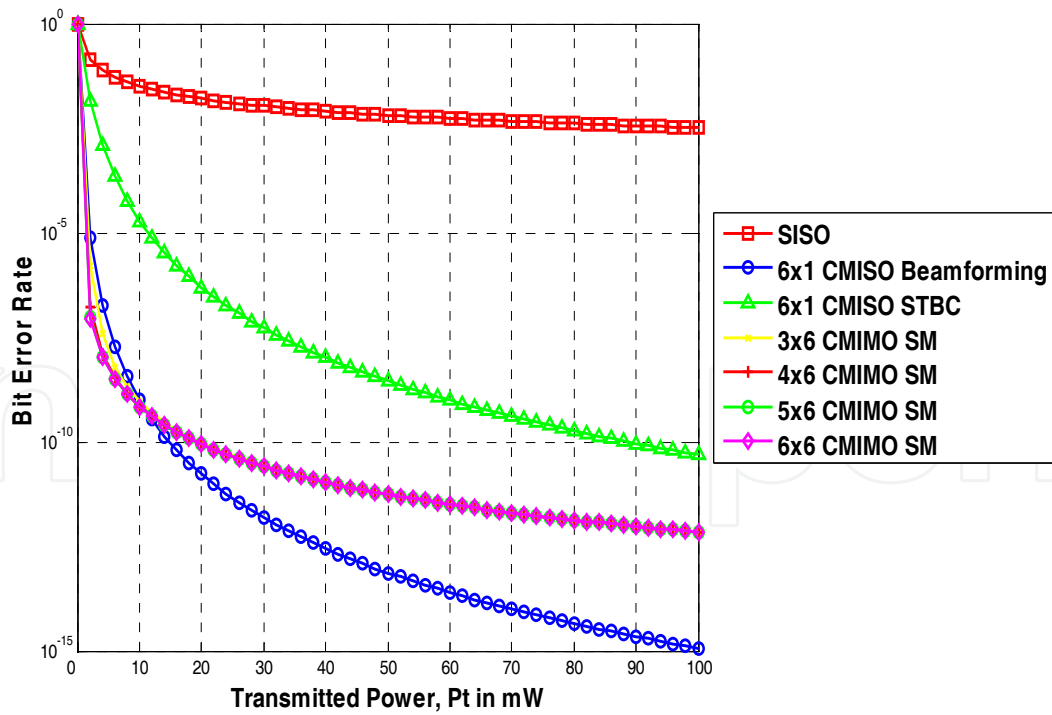

Fig. 13. BER vs. transmission power for various cooperative schemes with $M = 6$ and $N = 1$ (Cooperative BF and Cooperative STBC) and various $M = 3, 4, 5$ and 6 for Cooperative SM with $N = 6$.

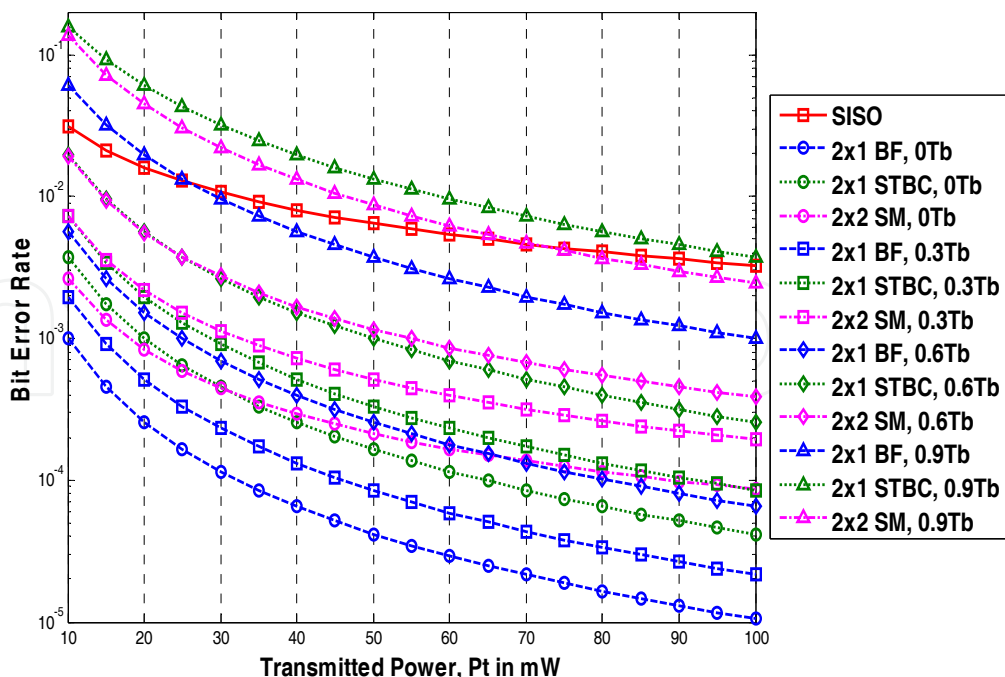

Fig. 14. BER vs. transmission power for various imperfect synchronisation cooperative schemes with $M = 2$ and $N = 1$ (Cooperative BF and Cooperative STBC) and $M = N = 2$ (Cooperative SM).

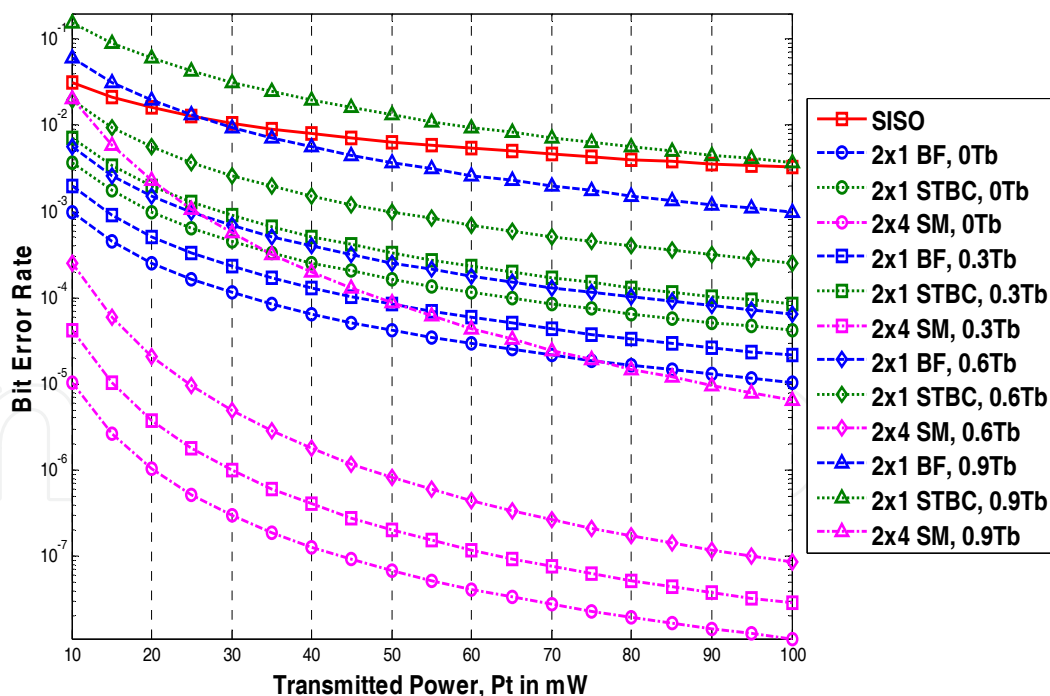

Fig. 15. BER vs. transmission power for various imperfect synchronisation cooperative schemes with $M = 2$ and $N = 1$ (Cooperative BF and Cooperative STBC) and $N = 4$ for Cooperative SM with $M = 2$.

6. Conclusion

This chapter has examined the major diversity techniques and various cooperative configurations, including BF, STBC and SM schemes in conjunction with performance evaluation and comparative literature. Both cooperative BF and STBC schemes utilise the MISO concept while the SM scheme utilises the MIMO concept. We have shown that the cooperative MISO BF is the most promising scheme to be implemented in WSNs due to the lowest error performance among others with the same diversity gain. Also, cooperative MISO BF outperforms other cooperative schemes in imperfect synchronisation scenarios. On the other hand, cooperative MIMO SM is more practical in terms of lower error performance and tolerance to clock jitter error when its diversity gain is higher than the others. In addition, cooperative MIMO SM provides a higher spatial rate as M grows.

The comparative study relates the diversity gain with the reduction in the transmission power by increasing the communication link reliability. However, in order to find the best or optimal scheme to be used in WSNs, we have to compare all the three schemes in terms of total energy consumption which must include both the transmission power and circuit power for each sensor node in the network. The discussion in this chapter can provide a basis for further study to find the optimal cooperative MIMO scheme when both transmission power and circuit power are considered for all required energy components of cooperative communications in WSNs.

7. References

- Alamouti, S.M. (1998). A Simple Transmit Diversity Technique for Wireless Communications, *IEEE Journal on Selected Areas in Communications*, vol. 16, pp. 1451-1458.
- Duman, T.M. & Ghayeb, A. (2007). *Coding for MIMO Communication Systems*, First ed. West Sussex, England: John Wiley & Sons Ltd.
- Foschini, G.J. (1996). Layered Space-time Architecture for Wireless Communication in A Fading Environment when using Multi-element antennas, *Bell Labs Technical Journal*, pp. 41-59.
- Golden, G.D.; Foschini, G.J.; & Valenzuela, R.A. (1999). Detection Algorithm and Initial Laboratory Results using the V-BLAST Space-time Communication Architecture, *Electronic Letters*, vol. 35, pp. 14-15.
- Gupta, G. & Younis, M. (2003). Fault-Tolerant Clustering of Wireless Sensor Networks, presented at IEEE Wireless Communications and Networking Conference (WCNC).
- Jafarkhani, H. (2005). *Space-Time Coding: Theory and Practice*, First ed: Cambridge University Press.
- Jagannathan, S.; Aghajan, H.; & Goldsmith, A. (2004). The effect of time synchronization errors on the performance of cooperative MISO systems, presented at IEEE Global Communications Conference (Globecom), Dallas, Texas, USA.
- Karl, H. & Willig, A. (2007). MAC Protocols, In: *Protocols and Architectures for Wireless Sensor Networks*, pp. 111-148, John Wiley & Sons, 978-0-470-09510-2, West Sussex, England.
- Kohvakka, M.; Kuorilehto, M.; Hannikainen, M. & Hamalainen, T.D. (2006). Performance Analysis of IEEE 802.15.4 and Zigbee for Large-scale Wireless Sensor Network

- Applications, *Proceedings of ACM International Workshop on Performance Evaluation of Wireless Ad hoc, Sensor, and Ubiquitous Networks*, pp. 1-6, Malaga, Spain.
- Kuorilehto, M.; Kohvakka, M.; Suhonen, J.; Hamalainen, P.; Hannikainen, M. & Hamalainen, T.D. (2007). MAC Protocols, In: *Ultra-Low Energy Wireless Sensor Networks in Practice*, pp. 73-88, John Wiley & Sons, 978-0-470-05786-5, West Sussex, England.
- Larsson, E.G. & Stoica, P. (2003). *Space-Time Block Coding for Wireless Communications*, First ed. Cambridge, UK: Cambridge University Press.
- Li, X. & Hwu, J. (2006). Performance of Cooperative Transmissions in Flat Fading Environment with Asynchronous Transmitters, presented at Military Communications Conference (MILCOM 2006), Washington DC, USA.
- Li, X. (2004). Space-Time Coded Multi-Transmission Among Distributed Transmitters Without Perfect Synchronization, *IEEE Signal Processing Letters*, vol. 11, pp. 948-951.
- Li, X.; Chen, M.; & Liu, W. (2004). Cooperative Transmissions in Wireless Sensor Networks with Imperfect Synchronization, presented at Conference on Signals, Systems and Computers, Pacific Grove, CA.
- Litva, J. & Lo, T.K.Y. (1996). *Digital Beamforming in Wireless Communications*: Artech House Publisher.
- Liu, Z.; Giannakis, G.B.; Zhuo, S.; & Muquet, B. (2001). Space-time coding for broadband wireless communications, *Wireless Communications and Mobile Computing*, vol. 1, pp. 35-53.
- Naqib, A.F. & Calderbank, R. (2000). Space-time codes for high data rate wireless communications, in *IEEE Signal Processing*, vol. 47, pp. 76-92.
- Proakis, J.G. (2001). Probability and Stochastic Processes, In: *Digital Communications*, pp. 17-36, McGraw-Hill, 0-07-232111-3, Singapore, Singapore.
- Rappaport, T.S. (2002). *Wireless Communications: Principles and Practice*, second ed. Upper Saddle River, NJ, USA: Pearson Education International.
- Seshadri, N. & Winters, J.H. (1993). Two Signaling Schemes for Improving the Error Performance of Frequency-division-duplex (FDD) Transmission Systems using Transmitter Antenna Diversity, presented at IEEE Vehicular Technology Conference.
- Simon, M.K. & Alouini, M.S. (2000). *Digital Communication over Fading Channels: A Unified Approach to Performance Analysis*: John Wiley & Sons.
- Singh, M. & Prasanna, V.K. (2003). A Hierarchical Model for Distributed Collaborative Computation in Wireless Sensor Networks, presented at IEEE International Parallel and Distributed Processing Symposium.
- Tarokh, V.; Jafarkhani, H.; & Calderbank, A.R. (1999). Space-time Block Codes from Orthogonal Designs, *IEEE Transactions on Information Theory*, vol. 45, pp. 1456-1467.
- Tarokh, V.; Seshadri, N.; & Calderbank, A.R. (1998). Space-time Codes for High Data Rate Wireless Communication: Performance Criterion and Code Construction, *IEEE Transactions on Information Theory*, vol. 44, pp. 744-765.
- Vucetic, B. & Yuan, J. (2003). *Space-Time Coding*. West Sussex, England: John Wiley & Sons Ltd.
- Winters, J.H. (1983). Switched diversity with feedback for DPSK mobile radio systems, *IEEE Transactions on Vehicular Technology*, vol. 32, pp. 134-150.

- Wittneben, A. (1991). Base Station Modulation Diversity for Digital SIMULCAST, presented at IEEE Vehicular Technology Conference.
- Yang, H.; Shen, H.-Y. & Sikdar, B. (2007). A MAC Protocol for Cooperative MIMO Transmissions in Sensor Networks, *Proceedings of IEEE Global Telecommunications Conference (GLOBECOM)*, pp. 636-640, Washington, USA.
- Yuksel, M. & Erkip, E. (2004). Diversity Gains and Clustering in Wireless Relaying, presented at IEEE International Symposium of Information Theory.

IntechOpen

IntechOpen

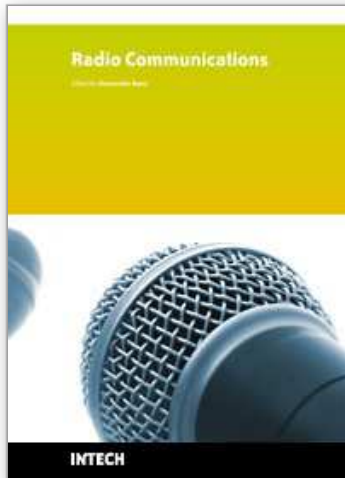

Radio Communications

Edited by Alessandro Bazzi

ISBN 978-953-307-091-9

Hard cover, 712 pages

Publisher InTech

Published online 01, April, 2010

Published in print edition April, 2010

In the last decades the restless evolution of information and communication technologies (ICT) brought to a deep transformation of our habits. The growth of the Internet and the advances in hardware and software implementations modified our way to communicate and to share information. In this book, an overview of the major issues faced today by researchers in the field of radio communications is given through 35 high quality chapters written by specialists working in universities and research centers all over the world. Various aspects will be deeply discussed: channel modeling, beamforming, multiple antennas, cooperative networks, opportunistic scheduling, advanced admission control, handover management, systems performance assessment, routing issues in mobility conditions, localization, web security. Advanced techniques for the radio resource management will be discussed both in single and multiple radio technologies; either in infrastructure, mesh or ad hoc networks.

How to reference

In order to correctly reference this scholarly work, feel free to copy and paste the following:

M. Riduan Ahmad, Eryk Dutkiewicz, Xiaojing Huang and M. Kadim Suaidi (2010). Cooperative MIMO Systems in Wireless Sensor Networks, Radio Communications, Alessandro Bazzi (Ed.), ISBN: 978-953-307-091-9, InTech, Available from: <http://www.intechopen.com/books/radio-communications/cooperative-mimo-systems-in-wireless-sensor-networks>

INTECH
open science | open minds

InTech Europe

University Campus STeP Ri
Slavka Krautzeka 83/A
51000 Rijeka, Croatia
Phone: +385 (51) 770 447
Fax: +385 (51) 686 166
www.intechopen.com

InTech China

Unit 405, Office Block, Hotel Equatorial Shanghai
No.65, Yan An Road (West), Shanghai, 200040, China
中国上海市延安西路65号上海国际贵都大饭店办公楼405单元
Phone: +86-21-62489820
Fax: +86-21-62489821

© 2010 The Author(s). Licensee IntechOpen. This chapter is distributed under the terms of the [Creative Commons Attribution-NonCommercial-ShareAlike-3.0 License](#), which permits use, distribution and reproduction for non-commercial purposes, provided the original is properly cited and derivative works building on this content are distributed under the same license.

IntechOpen

IntechOpen