

We are IntechOpen, the world's leading publisher of Open Access books Built by scientists, for scientists

4,800

Open access books available

122,000

International authors and editors

135M

Downloads

Our authors are among the

154

Countries delivered to

TOP 1%

most cited scientists

12.2%

Contributors from top 500 universities

**WEB OF SCIENCE™**Selection of our books indexed in the Book Citation Index
in Web of Science™ Core Collection (BKCI)

Interested in publishing with us?
Contact book.department@intechopen.com

Numbers displayed above are based on latest data collected.

For more information visit www.intechopen.com

Residential Noise Control Requirements for Powerline Communications Channel

Edward Guillen, Julian Lopez and Daniel Padilla
Telecommunications Engineering Department
"Nueva Granada" Military University Bogota,
Colombia

1. Introduction

Power line communications -PLC- is a technology that uses the electric grid for data transmission. Although the electrical channels were not designed to carry data, the implementation of PLC allows the using of a single channel for both electric and information transmission.

Even though the PLC technology initially aimed at transferring low rate control data between electrical stations, the communications over electric channels have been widely implemented not only for control data transmission but also for establishing high rate data, voice and video communications.

Communications by power lines, begun as a slow analog communications technology, and recently and recently has become in a wide band technology that has been compared with wireless LAN solutions [1]. High-speed home network solutions have been developed to provide connectivity by wireless or wired mediums including 802.11 -WLAN-, 802.15 -WPAN- and high speed 1394. One of PLC's greatest advantages is the use of low power residential lines with non impact over the electrical circuits, sharing the medium for both power and communications solutions. Electric companies invest on wired Internet access to achieve low cost solution for fixed Internet access as last mile solution and they can use the system to gain control over energy meters and it can be used for demotic applications using electrical appliances networks.

The initial PLC standard for PLC home networking is HomePlug 1.0 [2] for LAN connectivity at every power outlet, and it has been implemented in a wide variety of commercial equipments such as routers, bridges, wireless access points, audio end points, speakers, VoIP phones and security cameras. HomePlug AV, supports entertainment applications such as HDTV and home theater throughout the home without new wires and provides this capabilities at competitive costs [3]. Recently, Telecommunications Industry Association -TIA- has adopted HomePlug 1.0 to be published in its standard TIA 1113, as the first multi-megabit power line communications standard approved by American National Standards Institute [4].

The first and only -ANSI- PLC standard defines operations, functions and interface characteristics of a system for medium speed networking using the medium of power line wiring based on Orthogonal Frequency-Division Multiplexing -OFDM-.

For PLC implementations on electrical Latin-American environments, most of the noise control regulations are difficult to complain or simply regulations do not exist, that's why this chapter tries to analyze the effects of noisy electrical wired channels over the network throughput in common scenarios, as well as define the residential noise control requirements for PLC implementation. The network model on noisy channels is described in section V.

2. PLC Technology Overview

This section is going to show the use of OFDM technology in PLC, a model of an electrical low power channel in a communications environment and a mathematical model of a PLC channel.

A. Orthogonal Frequency-Division Multiplexing -OFDM

In OFDM, a whole channel is divided into many narrow sub-channels, which are transmitted in parallel. With OFDM technique, the duration of a symbol is increased and the Inter Symbol Interference -ISI- is reduced [7]. HomePlug 1.0 uses 84 OFDM sub-carriers equally spaced as the physical layer. The first subcarrier start at 4.49MHz and the last one is at 21MHz, in a bandwidth of 16.21MHz. To avoid intersymbol interference in the time-domain and intercarrier interference in the frequency domain, a cyclic prefix comprising the last 172 samples from the inverse fast Fourier transform (IFFT) interval of 256 samples is added to the beginning of the IFFT interval to form a 428-sample OFDM symbol. HomePlug 1.0 used the Robust Mode of OFDM when the channel is degraded and in this mode all subcarriers are activated [8]. The 84 subcarriers distribution is shown in Figure 1.

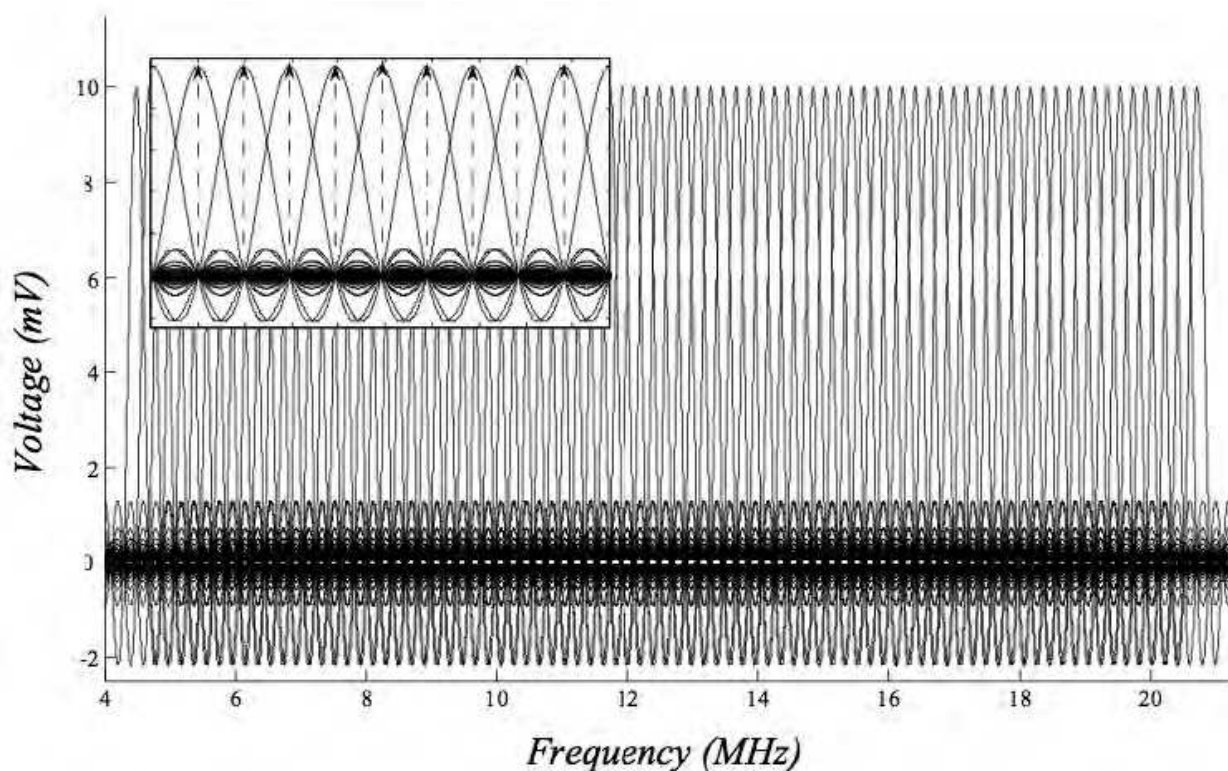

Fig. 1. OFDM spectral distribution

B. Features of PLC Transmission Channel

An electric transmission line has been designed to transmit power in low frequency and causes a variance of the impedance because of the fact that a wide variety of appliances are connected to the outlet. Some statistical analysis and achieved measurements has shown a medium impedance of 100 to 150 ohms. However those values tend to decrease with frequencies bellow to 2MHz. The attenuation of a powerline increases with the distance according to the impedance components that are composed by resistance per unit length, $-R'$, inductance per unit length, $-L'$, conductance per unit length, $-G'$, and capacitance, $-C'$, per unit length. The parameters have a closed relationship with the frequency and the line impedance can be described as can be seen on equation (1) [9].

$$Z_L = \sqrt{R'(f) + \frac{j2\pi f \cdot L'(f)}{G'(f)} + j2\pi f \cdot C'(f)} \quad (1)$$

Where $\omega = 2\pi f$. Another component to analyze is the propagation constant γ , whose equation is formulated in (2).

$$\gamma(f) = \sqrt{[R'(f) + j2\pi f \cdot L'(f)] \cdot [G'(f) + 2\pi f \cdot C'(f)]} \quad (2)$$

It's also usual to describe the propagation constant as a function of the next complex equation.

$$\gamma(f) = \alpha(f) + j\beta(f) \quad (3)$$

Where $\alpha(f)$ as the real part, represents the line attenuation factor and $\beta(f)$, as the imaginary part, is the line phase factor and the angle variation between the transmitted and received signals.

C. Mathematical Model of a PLC Channel

In [9], a PLC channel is described as a discrete-time impulse response in a path i with a certain delay τ_i and certain attenuation factor G as is shown in (4)

$$h(t) = \sum_{i=1}^N C_i \cdot \delta(t - \tau_i) \quad (4)$$

In PLC channels the equation (4) is defined for frequency ranges between 500 KHz to 30 MHz [10]. The transfer function in the frequency domain can be described as follows.

$$H(f) = \sum_{i=1}^N g_i \cdot \exp[-(a_0 + a_1 f^k) \cdot l_i] \cdot \exp(-j2\pi f \tau_i) \quad (5)$$

Where g_i is a weighting factor representing the product of the reflection and transmission factors along the path; l_i is the path length. The adjustable parameters a_0 , a_1 and k are used to

show the attenuation of the channel with k values from 0,5 to 1 and N paths from 5 to 50 for the above range of frequencies.

3. Noise on PLC Channels

It is not possible to analyze power line channels as a traditional noisy channel with additive white Gaussian noise -AWGN-. Zimmermann [5, 6] classifies PLC noise into five classes according to Figure 2.

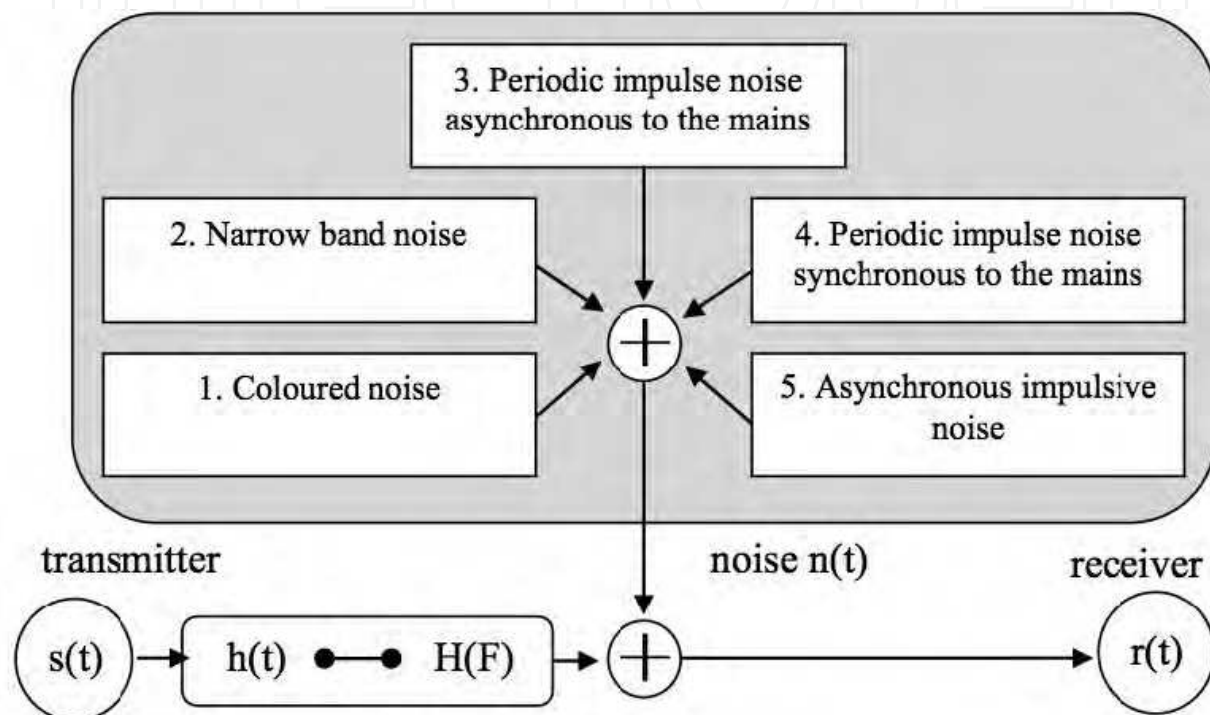

Fig. 2. Classification of Noise on PLC Channels

Coloured noise, narrow band noise and periodic impulsive noise are usually modeled as background noise because they remain stationary from seconds to even hours. Periodic impulsive noise synchronous to the mains and asynchronous impulsive noise may cause bit or burst errors over the transmission, although they are time variant. A complete theoretical analysis on shown noises in Figure 2 can be found on [5, 6, 11, 12, 13].

4. Noise and Throughput on PLC

In order to probe the throughput variations caused by noisy channels in electrical Latin-American environments, five scenarios were created with a PLC network, in a common electrical distribution home network, with 120 AC volts and 60Hz. Figure 3 shows the basic implementation. The electric noise source is connected in the outlet over the same electrical circuit using common wall sockets depending upon the scenario. In a first stage, the noise source is connected at the Tx host side, the measurements are taken and the noise source is connected at the receptor side for finally measurements.

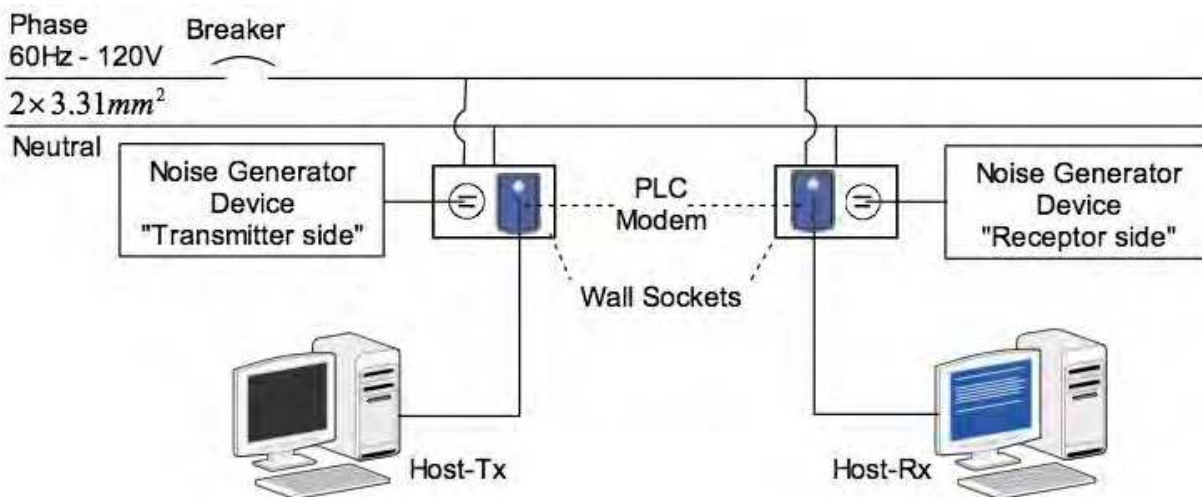

Fig. 3. Basic Networking Model

The probed scenarios are five. In the scenario 1, Base Scenario, traffic is sent over a free electrical generated noise by sending files between 20MB to 100MB, in steps of 20MB incremented once every 50 samples. The collected data is: delay, bit length on the frames and throughput. This scenario is intended to evaluate transmission on normal conditions, and to compare results in noisy scenarios. The same files and variations are going to be used in every single scenario in order to collect data.

In the scenario 2, the channel is exposed to a 500 watts inductive load in the 90% of the transmission time that was taken in scenario 1. At scenario 3, an astable inductive load is connected to the electrical network. The periods of the generation are 2.5 sg, 5 sg and 10sg and are called *tiAT*. Every single period has the same value during the whole transmission. In the fourth scenario, an inductive and resistive load of 40 watts is connected to the electric channel. The load is attached during all transmission time. At scenario 5, an electronic and resistive load is connected along the channel during the transmission time.

The effects of the proved noise sources over the low voltage home network and the scenarios results comparison are shown in part A. In the second results part, the noises that affected the probed channel are analyzed with the statistical resources.

A. PLC Throughput Results

In a protocol analyzer installed on the transmitter equipment, the total time for the transference was analyzed for the transmission path between the hosts. The total bit length was also measured and the throughput was calculated, in Mbps, with the scenarios described before. The obtained throughput is compared with the base scenario and the noise effect over the channel is obtained.

1) Scenario1 vs. Scenario2

Figure 4 shows the throughput for: scenario without noise generation (scenario1), scenario2 with the noise source connected at the Tx side and scenario2 with the noise source attached at the Rx Host side.

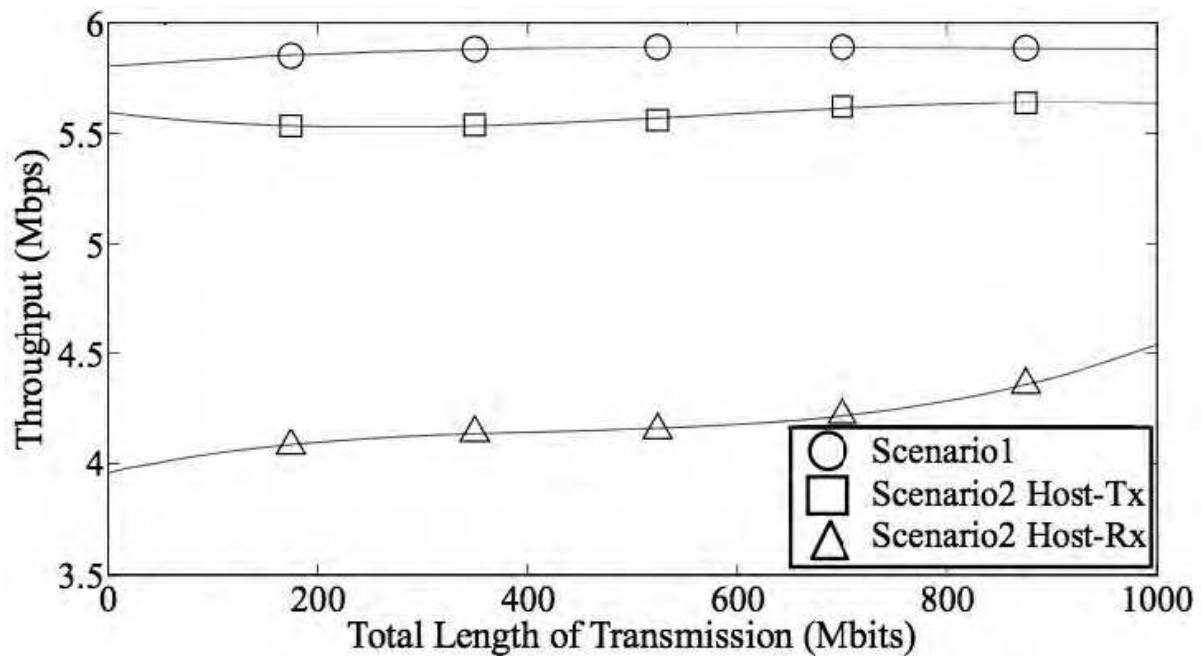

Fig. 4. Throughput, Scenario 1 Vs Scenario 2

When the noise is generated at the transmission side, it is possible to see a throughput reduction of 5%, compared with the throughput obtained in the scenario 1, but when the noise generation occurs in Rx side, as probed scenario 2, throughput decreases in 29% compared with the base scenario. In the last case, the 58% of the transmitted bits are transferred during the noise generation, afterwards, the throughput increases and time decreases as it is shown in Figure 5, with files of 20MB, 40MB, 60MB, 80MB and 100 MB. Figure 5 a), b), c), d) and e) shows the instant in which the inductive load is turned off. In Figure 5 f), when the transmitted file is 100MB of length, the throughput is constant along the communication, as shown in Figure 5 f).

2) Scenario3 vs. Scenario2

As explained for scenario 3, three comparisons had been made according to the times of t_{IAT} . In the Figure 6 a), the throughput for $t_{IAT} = 10\text{sg}$ is shown. The throughput decreases when the astable load is connected at the Tx-host side in 0.82% and the throughput diminish in 0.96% when the load is attached at the Rx side.

For $t_{IAT} = 5\text{sg}$, the throughput has a higher alteration for lower bit-lengths as it is shown in Figure 6 b). The decrease for this compared scenario is 1.28% and 1.89% for the astable inductive load connected at the Tx-side and at the Rx- side, respectively.

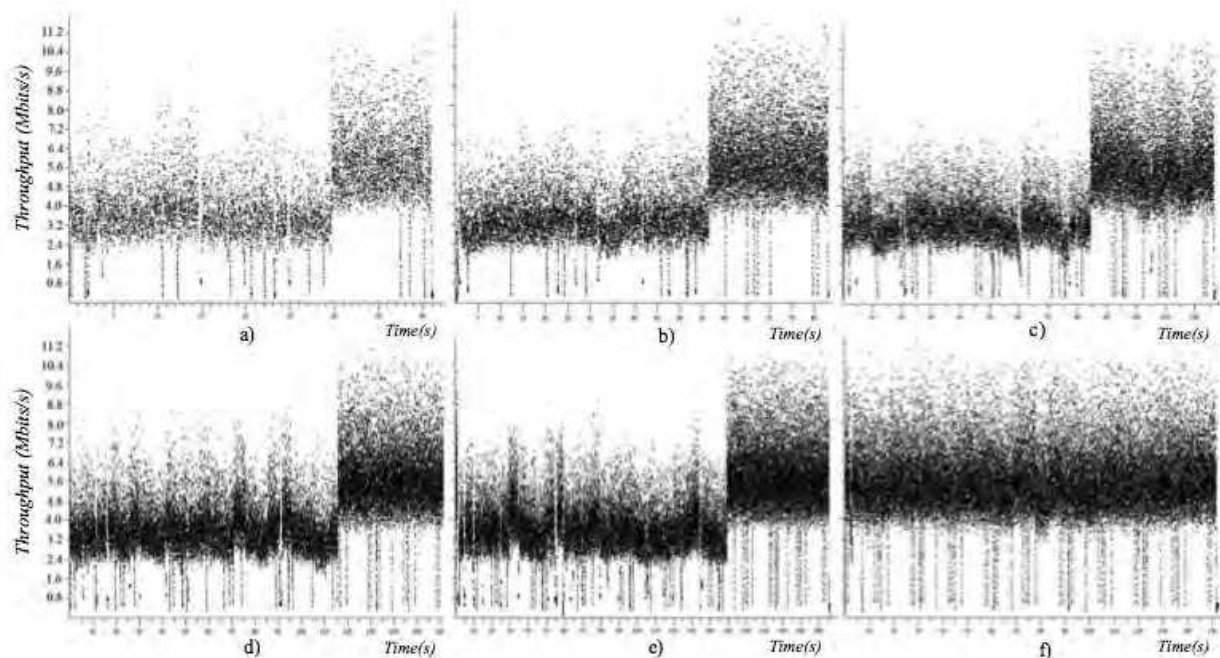

Fig. 5. Scenario 2 at Rx side, with files of a) 20MB, b) 40MB, c) 60MB, d) 80MB and e) 100MB. f) At the Tx-side with 100MB

3) Scenario3 vs. Scenario1

As explained for scenario 3, three comparisons had been made according to the times of t_{IAT} .

In the Figure 6 a), the throughput for $t_{IAT} = 10\text{sg}$ is shown. The throughput decreases when the astable load is connected at the Tx-host side in 0.82% and the throughput diminish in 0.96% when the load is attached at the Rx side.

For $t_{IAT} = 5\text{sg}$, the throughput has a higher alteration for lower bit-lengths as it is shows in Figure 6 b). The decrease for this compared scenario is 1.28% and 1.89% for the astable inductive load connected at the Tx-side and at the Rx- side, respectively.

The last compared scenario, with $t_{IAT} = 2.5\text{sg}$, shows throughput differences of 1.45% with the load at the Tx-side and of 5% with the load at the Rx-side. These differences can be seen in Figure 6 c), always compared with the scenario 1.

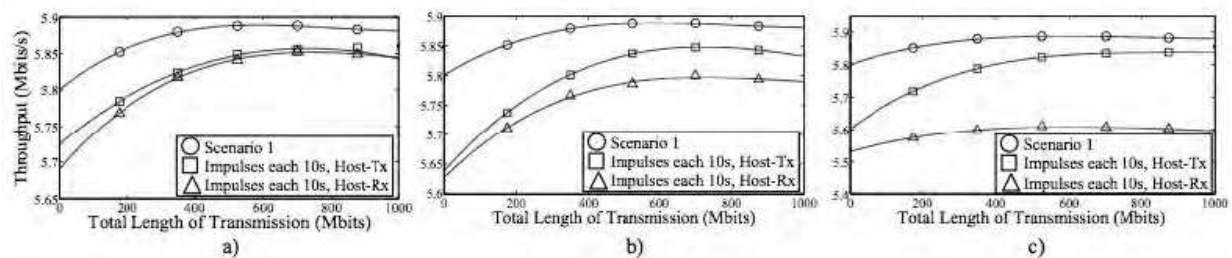

Fig. 6. Throughput for scenario3 for astable period times of a) 10sg, b) 5sg, c) 2.5sg

It is also possible to analyze the transmission time with the throughput for each period of the scenario 3 with the transmitted file of 60MB; this case is shown in Figure 7.

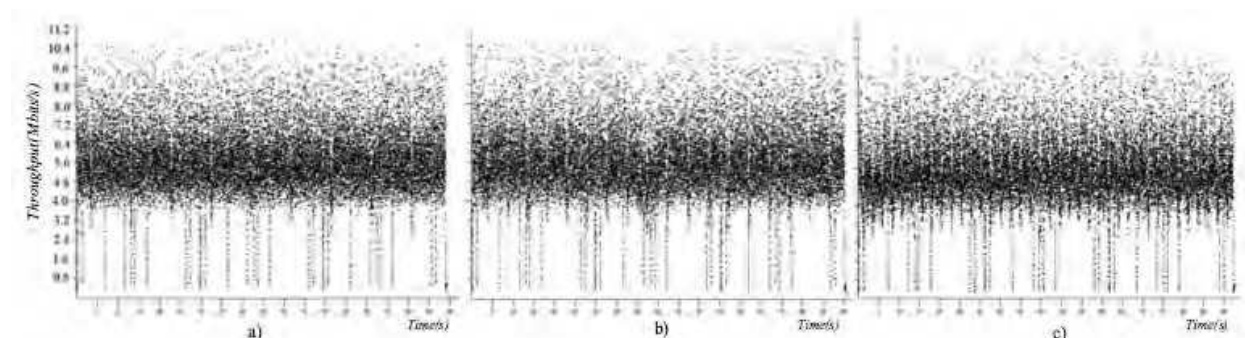

Fig. 7. Scenario 3 at the Rx-side with a transmission of 60MB with r.. of a) 10sg, b) 5sg and c) 2.5sg

It is possible to see, on each case, white spaces on the graph that occurs in the edge of the load activation at the t_{IT} period, as seen on Figure 7. When the load is attached at the Tx-side those spaces are not possible to distinguish. Although most of the graphs and data are not available for this paper we can provide them upon an email request.

4) Scenario4 vs. Scenario1:

The throughput result shows that there is a decrease of 0.33% when this kind of load is connected at the Tx-side and there is a decrease of 5.66% at the Rx-side. As it occurs in most of the cases, the throughput is minimal affected when the noise is generated at the Tx-side, but it is meaningfully affected when the noise is connected at the Rx-side.

The throughput results for the scenario 4 are shown in Figure 8. It is interesting to see that the maximum loss occurs with bit-lengths transmission of less than 400Mbits and with noise generated at the Rx-side.

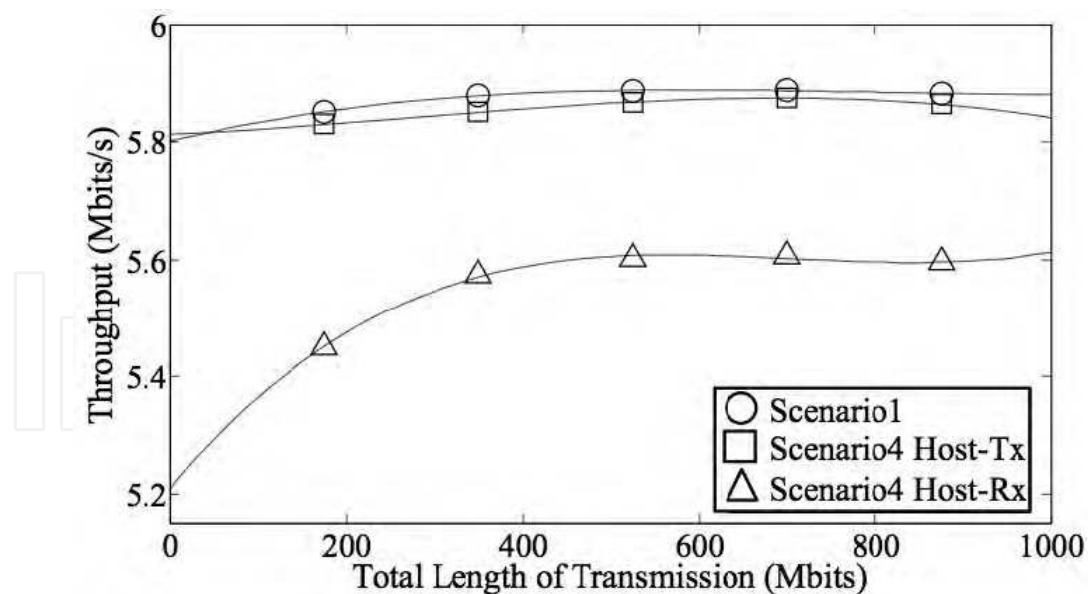

Fig. 8. Throughput for scenario 4

5) Scenario5 vs. Scenario1:

In the scenario 5 the differences are very small compared with scenario 1 only a decrease of 0.24% and 0.26% with the load attached at the Rx-side and at the Tx-side respectively. The results can be seen on Figure 9

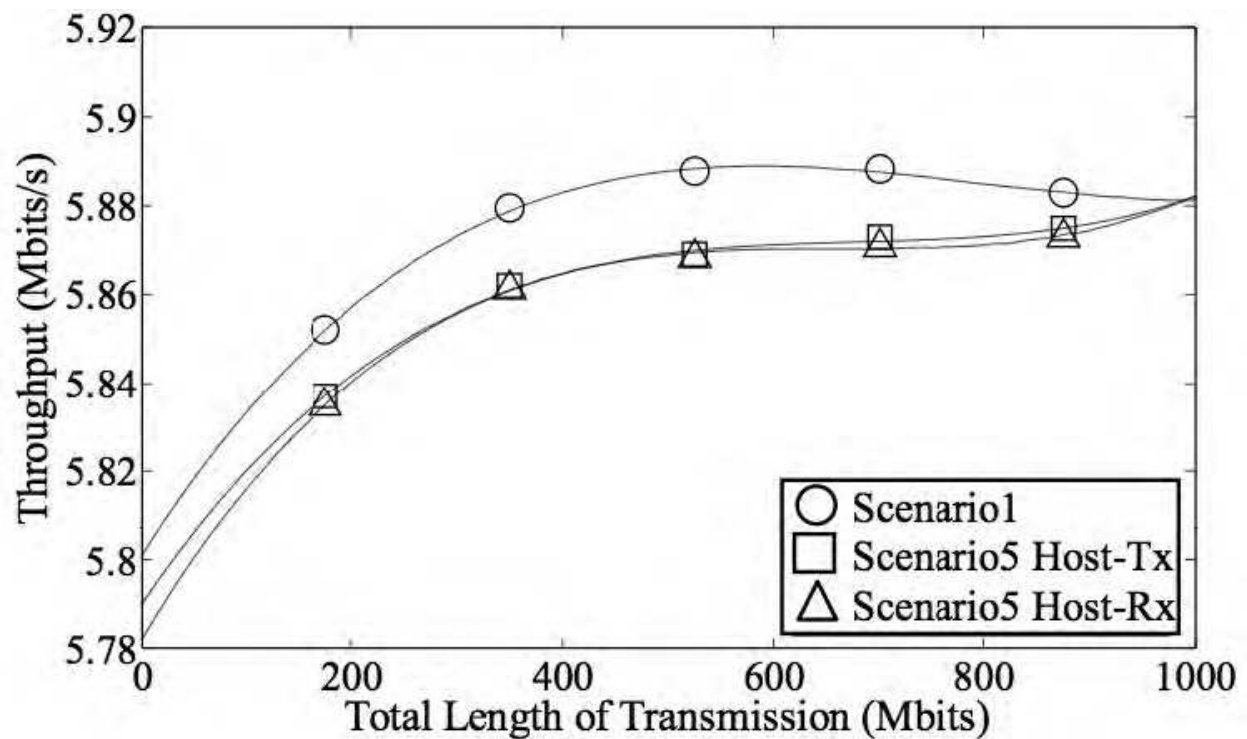

Fig. 9. Throughput for Scenario 5

A summary of the throughput affectation in all the scenarios compared with scenario 1 for PLC is shown in Table 1. The results show a major throughput decrease with the characterized impulsive noise.

Scenario 1 compared with:	Load Connected at:		Represented Noise Set
	Host-Tx (%)	Host-Rx (%)	
Scenario 2	5,00	29,0	Impulsive Noise
Scenario 3 10s	0,82	0,96	
Scenario 3 5.0s	1,28	1,89	
Scenario 3 2.5s	1,45	5,00	
Scenario 4	0,33	5,66	Background Noise
Scenario 5	0,24	0,26	

Table 1. Throughput Reduction for Every Single Scenario Compared with Base Scenario

B. Noise affecting PLC channels

The noises that are affecting the PLC channel during the probed scenarios, can be analyzed as impulsive noise and as generalized background noise, both of them are specified as follows:

1) Impulsive Noise

In the generated noise within the scenario 3, the waveforms that are showed in Figure 10 was obtained.

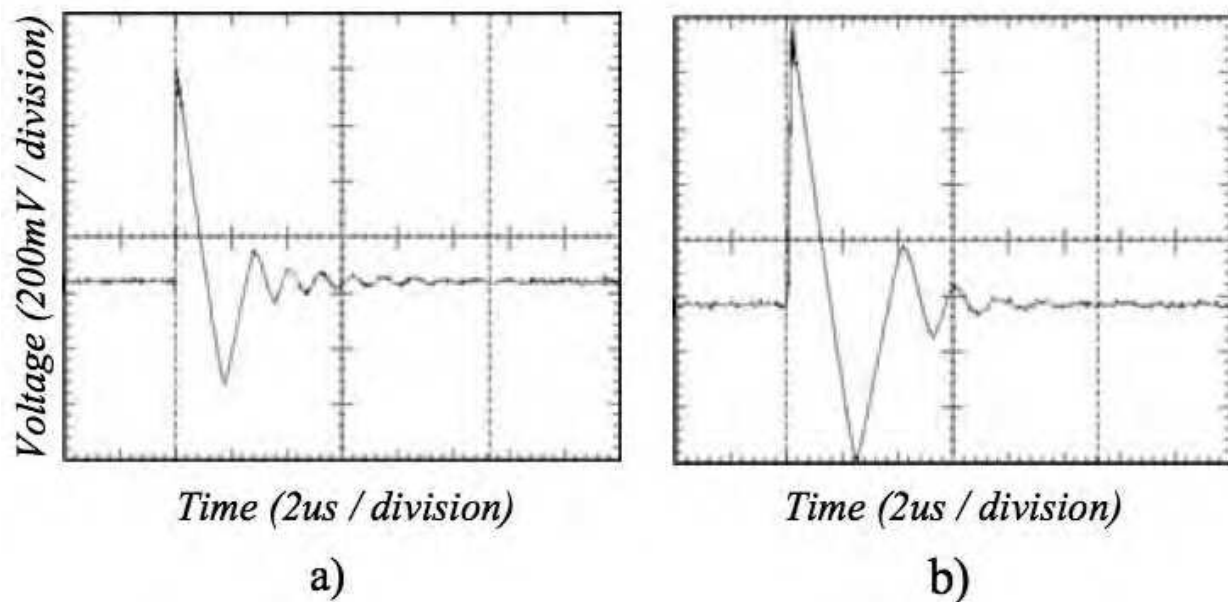

Fig. 10. Impulsive noise obtained within the scenario 3 a) casel, b) case2 The impulsive noise can be modeled by the equation (6)

$$n_s(t) = \sum_{i=1}^{I_s} A_i \sin \left[2\pi f_i (t - t_{arr,s}) + \alpha_i \right] e^{\left(\frac{t-t_{arr,s}}{\tau_i} \right)} \cdot u \left(\frac{t-t_{arr,s}}{t_{w,s}} \right) \quad (6)$$

Where A_i defines the amplitude of the impulse, f_i and α_i , the frequency and phase of the i -esime impulse, $t_{arr,s}$ specifies the time where the impulses starts, $t_{w,s}$ the time on seconds of the signal $u(t)$ that is the shape of the pulse. In order to calculate the power of the impulses, the relation of Zimmermann and Dostert [5, 6], is written in the equation (7)

$$P_{n_s(t)} = \frac{1}{t_{w,s}} \int_{t_{arr,i}}^{t_{arr,i}+t_{w,s}} n_s(t)^2 dt \quad (7)$$

The results of the analysis can be seen in the Table 2

Impulse	Duration $t_{w,s}(\mu s)$	Amplitude $A_i (mV)$	Frequency $f_i (Khz)$	Power dBm
Case 1	11.27	766	778	14.69
Case 2	11.10	975	403	16.53

Table 2. Results of the scenario 3

In the scenario 2, the impulses waveforms were analyzed in time domain and frequency domain as it is shown in the Figure 11

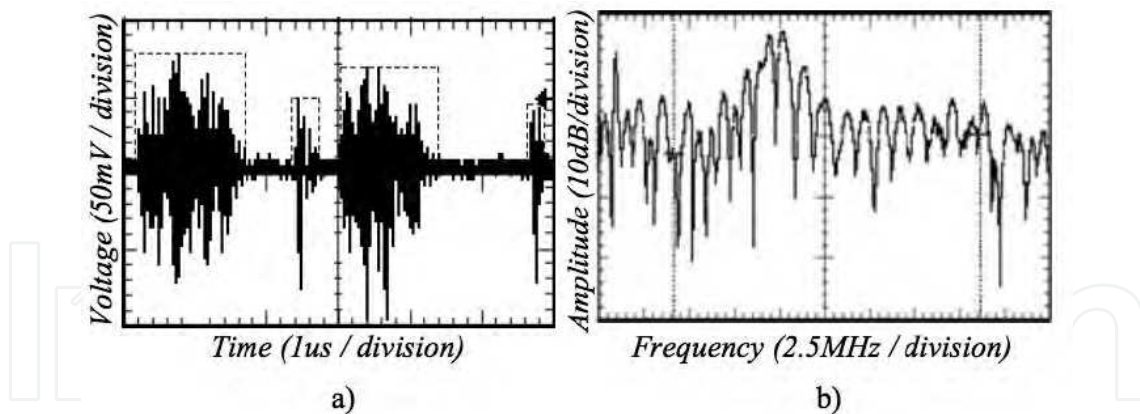

Fig. 11. Impulsive noise measured for scenario 2

The noise presented in scenario 2 has the duration of $t_{w,s}$ with a time between impulses of $t_{arr,s}$ and an amplitude A_i . This noise is presented during the complete period in which the inductive load is connected. In the spectral waveform of the Figure 11 (b), the reference level is -45dBm, span of 25MHz, and the range limited by the cursors lines is the bandwidth of the PLC technology.

In order to generalize the noise 200 samples of the noises are taken and analyzed with a statistical tool. The amplitudes obtained are modeled by a Weibull Probability Density Function (PDF), as it is suggested for similar noises on ADSL analysis [15, 16].

The PDF Weibull can be described by equation (8) where a is the continuous variable of amplitude, α is a scale factor and β is a shape parameter, with all positive values.

$$f(a) = \frac{\beta}{\alpha} a^{\beta-1} \exp \left[- \left(\frac{a}{\alpha} \right)^\beta \right], a > 0 \quad (8)$$

The PDF obtained with the Weibull approach appears in the Figure 12 a), with the calculated parameters.

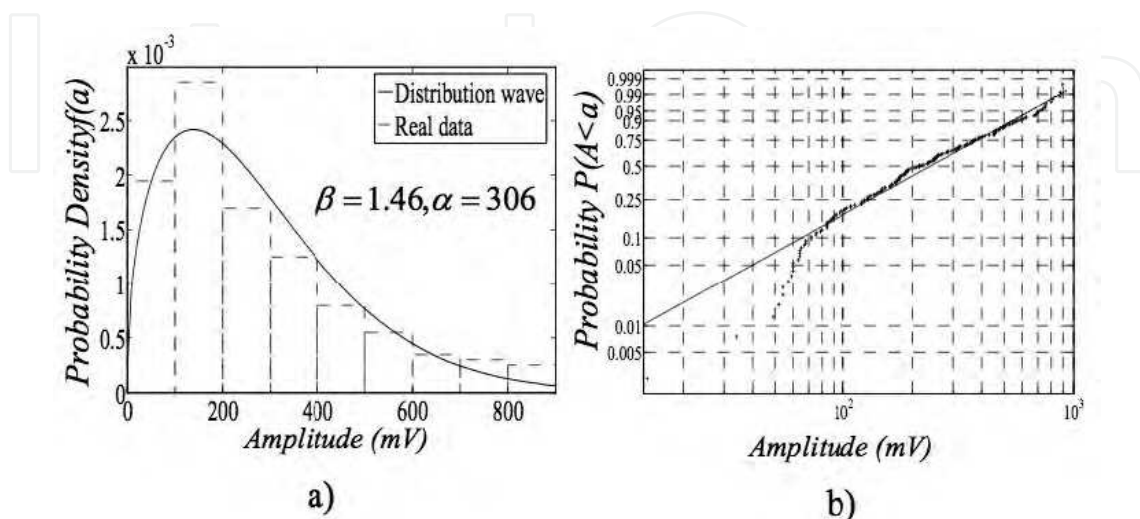

Fig. 12. Weibull Distribution a) PDF, b) Amplitude function

The Fig 12. b) shows the cumulative theoretical probability for Weibull distribution. The next two variables are represented for an Exponential PDF that is symbolized by the equation (9), where x represents the continuous variable of the distribution and is equivalent to the impulses duration w , while the inter-arrival times is expressed by r .

$$f(x) = \lambda e^{-\lambda x}, x \geq 0 \quad (9)$$

The representation of the probability density function of w is shown in Figure 13 a), where a higher probability of impulses duration can be found before of $16\mu\text{s}$.

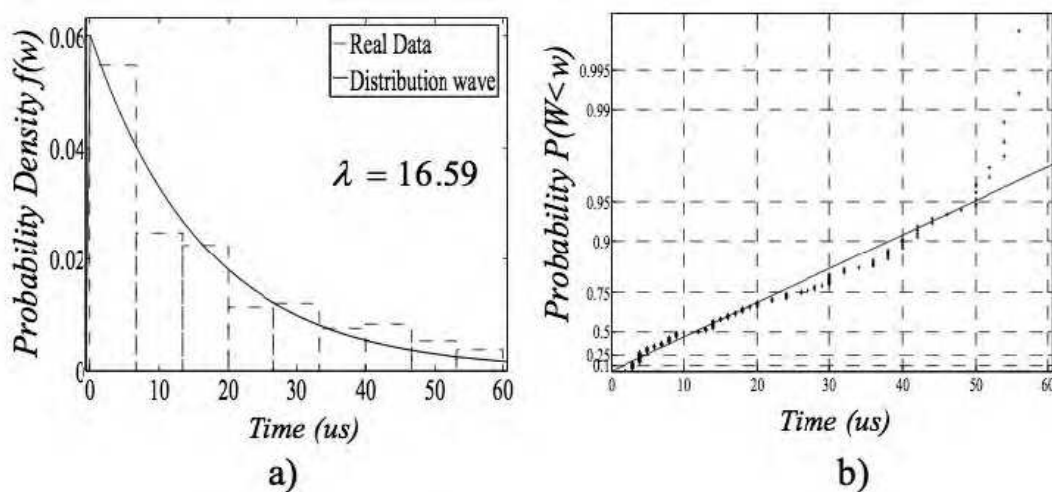

Fig. 13. Exponential function for the impulses duration a) PDF b) Distribution Function

The inter-arrival time between impulses has a probability density function $f(r)$ as it is shown in Figure 14 a). There are not impulses for times below of $40\mu\text{s}$. The plotted data fitted the theoretical function.

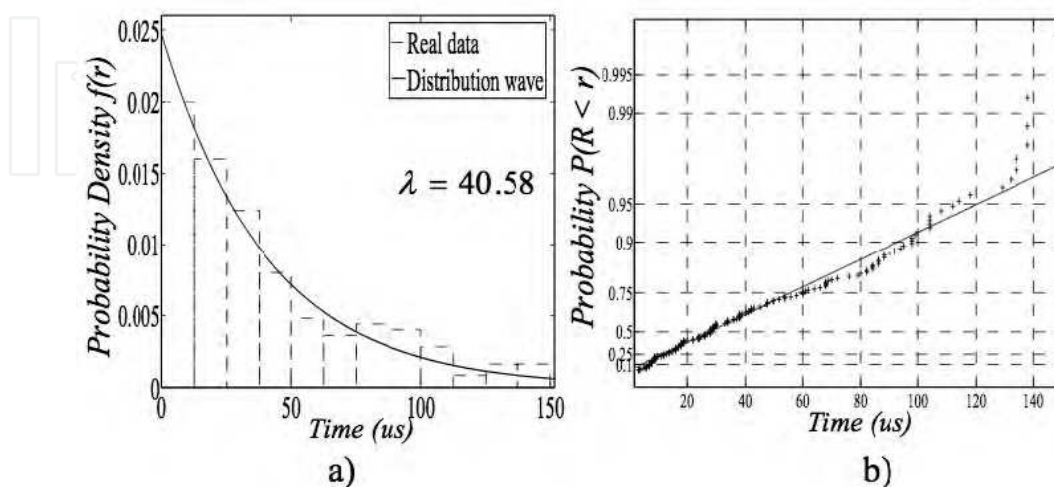

Fig. 14. Exponential function distribution for inter-arrival times between impulses a) PDF b) Exponential probability

As a summary of the analyzed variables, the Table 3 shows the distributions and its parameters.

Variable	Distribution	Mean	Variance
Amplitude (a)	Weibull	277.2 mV	37244 mV ²
Duration (w)	Exponential	16.595 μ s	275.39 μ s ²
Inter-arrival times (r)	Exponential	40.58 μ s	1646.5 μ s ²

Table 3. Mean and variance for the analyzed

2) Generalized Background Noise

The set of noise belong to the background noise do not show an important affectation to the throughput on the communication network when the load is connected at the Tx side. The phenomenon is explained by the low power density of this kind of noises in the range of frequencies used by PLC, see Figure 15.

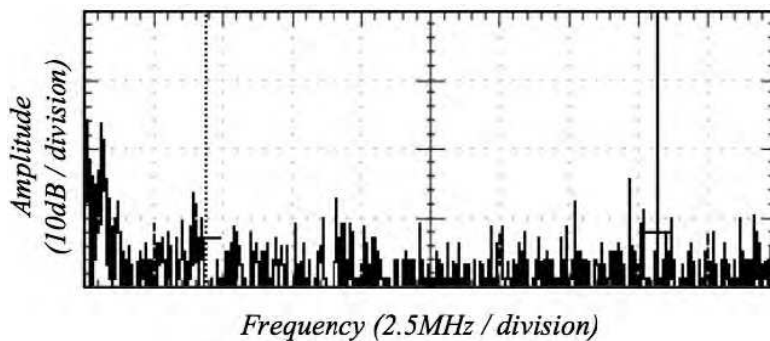

Fig. 15. Spectral Plot for the Background Generalized Noise. Spam 25MHz, Center 12.5MHz, Reference -47dB

5. Network model on noisy channels

The control requirements for the previously described coloured noise, narrow band noise, periodic impulsive noise and asynchronous impulsive noise, can be separately analyzed in two different scenarios.

A. In-home Scenario

In-home network model controls the noises on electrical channels within a local area network, -LAN-, by implementing band-pass and band-stop filters as given in Figure 16. The communication signals within the powerline infrastructure is bandpass filtered at each PLC client connection point by installing PLC splitters. The noise control requirement isolates the noisy signals on communication channels.

The application in-home network requires bandwidth control affected by the analyzed noises. The scenarios showed enough control with filters applied not at the noise source but at the electric connection in the data equipment. The neighbors' electric networks are not expected to be affected by the noises in the PLC LAN but they could be affected by external noises even though their implications are filtered by the suggested appliances and it is not necessary to install special filters at the main electrical panel.

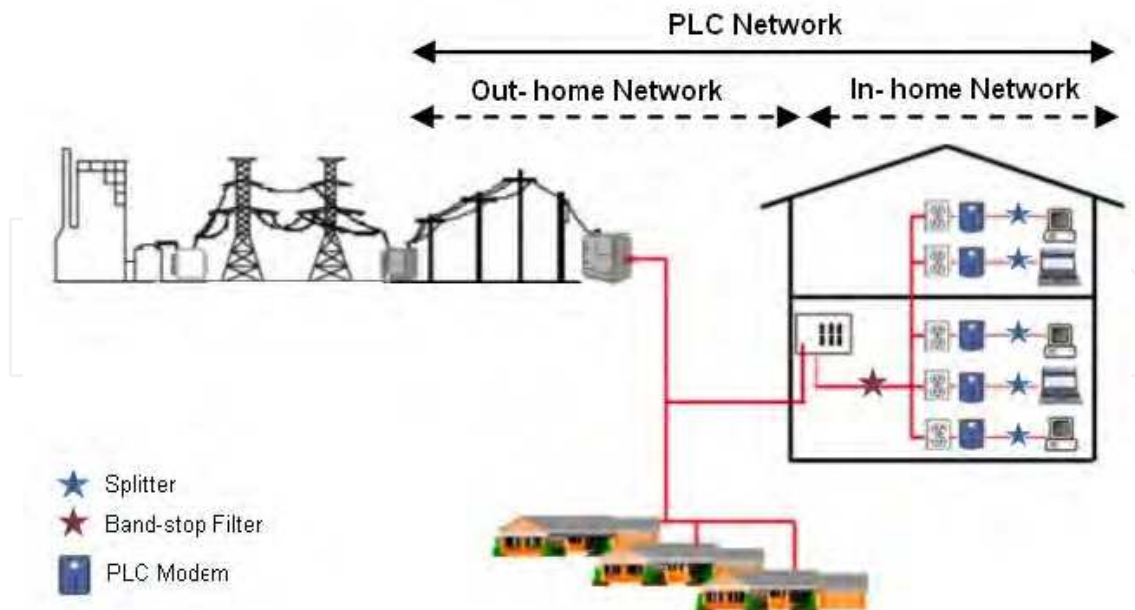

Fig. 16. In-home Network Model on Noisy Channels

On the other hand, a band-stop filter is implemented at the in-home electric provision point. The proposed noise control filters the not desired outgoing and incoming communication signals of the house.

B. Powerline ISP Scenario

PLC Networks can be used by electric distributors to offer internet access as add value. The analyzed noise can affect the throughput in the distribution and it is necessary to install filters not only at the power source per PLC connection but also the filter must be installed at the main electrical panel. The general scheme can be seen in Figure 17.

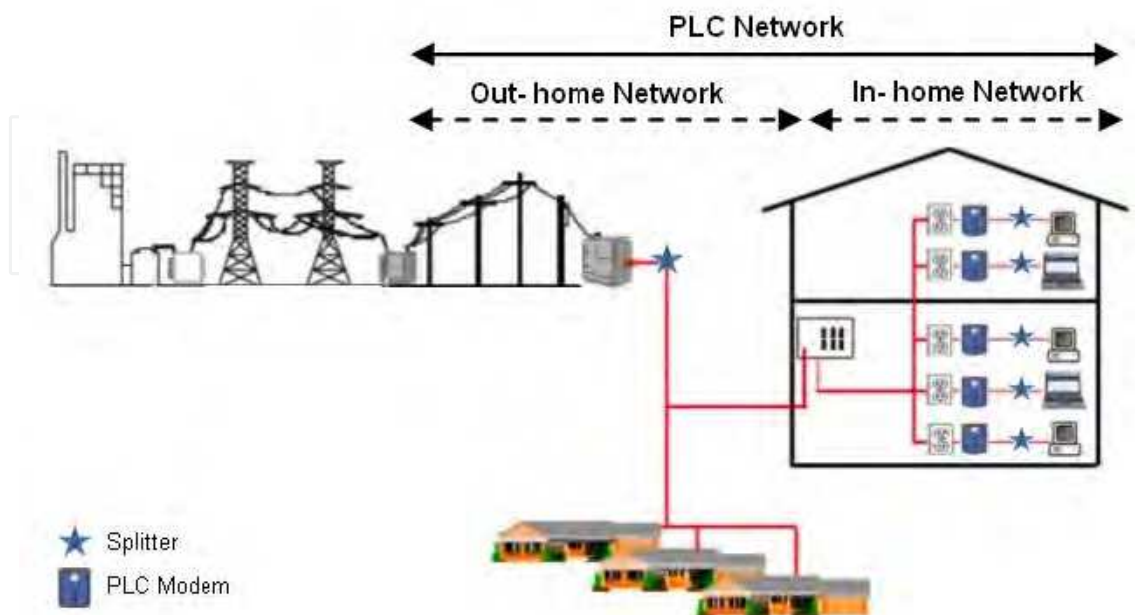

Fig. 17. In-home Network Model on Noisy Channels

6. Conclusion

Noises on powerline communication channels such as coloured noise, narrow band noise, periodic impulsive noise and asynchronous impulsive noise affect PLC network throughput. However, these noises can be successfully controlled by band-pass and band-stop filters installed on strategic PLC network connection points.

It's necessary to establish a model to probe if the noise measurements on this work can be applied on industrial environments and if the noise can affect PLC networks installed on near locations to PLC ISP distributors.

7. References

- [1] Lee, M.K.; Latchman, H.A.; Newman, R.E.; Katar, S.; Yonge,L., "Field Performance Comparison of IEEE 802.11b and HomePlug 1.0" Proceedings. LCN 2002. 27th Annual IEEE Conference on Local Computer Networks, 2002, PP: 598 -599.
- [2] M. K. Lee, R. Newman, H. A. Latchman, S. Katar, and L. Yonge, "HomePlug 1.0 Powerline Communication LANs-Protocol Description and Comparative Performance Results," International Journal on Communication Systems on Powerline Communications, pp. 447-473, 2003.
- [3] D. Webgner, O. Logvinov, "HomePlug Alliance position statement", IEEE BoPL meeting, July 2004
- [4] American National Standard Institute, ANSI. "TIA 1113: Medium-Speed (up to 14 Mbps) Power Line Communications (PLC) Modems using Windowed OFDM", Telecommunications Industry Association, TIA, May 2008.
- [5] Zimmermann, M.; Dostert, K., "An Analysis of the Broadband Noise Scenario in Powerline Networks," Proceedings of the 4th International Symposium on Powerline Communications and Its Applications. Limerick (Ireland), vol. 138, 2000.
- [6] Zimmermann, M.; Dostert, K.; "Analysis and modeling of impulsive noise in broad-band powerline communications", IEEE Transactions on Electromagnetic Compatibility, Volume 44, Issue 1, Feb. 2002, pp 249 -258
- [7] Li, Y.; Cimini, L.J., Jr.; Sollenberger, N.R.; "Robust Channel Estimation for OFDM Systems with Rapid Dispersive Fading Channels", IEEE Transactions on Communications, Volume 46, Issue 7, July 1998 pp 902- 915.
- [8] Hsu, C.; Neng Wang; Wai-Yip Chan; Jain, P.; "Improving HomePlug Power Line Communications with LDPC Coded OFDM", 28th Annual International Telecommunications Energy Conference, 2006. INTELEC '06. Sept. 2006 pp 1 - 7 [9] H. Hrasnica, A. Haidine, and R. Lehnert, Broadband Powerline Communications: Network Design: Wiley & Sons, 2004, pp. 52-55
- [10] T. Sartenaer, Multiuser communications over frequency selective wired channels and applications to the powerline access network. PhD Thesis, Département d'électricité, Université Catholique de Louvain, Septembre, 2004
- [11] R. Pighi and R. Raheli, "Linear Predictive Detection for Power Line Communications Impaired by Colored Noise," EURASIP Journal on Advances in Signal Processing, vol. 2007, pp. 1-12, 2007.
- [12] P. Scherz, "Switching Regulator Supplies (Switches)," in Practical Electronics for Inventors: McGraw-Hill/TAB Electronics, 2000, pp. 292-293.

- [13] M. Babic, M. Hagenau, K. Dostert, and J. Bausch, "Theoretical postulation of PLC channel model," IST Integrated Project Deliverable D4v2. 0, The OPERA Consortium, March, 2005
- [14] R. Boden, "Realistic modeling spectral and amplitude distribution characteristics of impulsive noise in ADSL broadband access networks," Proc. 10th International OFDM Workshop, Hamburg, pp. 46-50, 2005
- [15] D. Umehara, S. Hirata, S. Denno, and Y. Morihira, "Modeling of Impulse Noise for Indoor Broadband Power Line Communications," International Symposium of Information Theory and its Applications, ISITA, (Seoul, Korea), 2006
- [16] E. Griful and G. Ponsati, "Tasa de fallo no constante, el modelo de Weibull y otros," in Fiabilidad industrial: Edicions UPC, 2003, pp. 41

IntechOpen



New Advanced Technologies

Edited by Aleksandar Lazinica

ISBN 978-953-307-067-4

Hard cover, 350 pages

Publisher InTech

Published online 01, March, 2010

Published in print edition March, 2010

This book collects original and innovative research studies concerning advanced technologies in a very wide range of applications. The book is compiled of 22 chapters written by researchers from different areas and different parts of the world. The book will therefore have an international readership of a wide spectrum.

How to reference

In order to correctly reference this scholarly work, feel free to copy and paste the following:

Edward Guillen, Julian Lopez and Daniel Padilla (2010). Residential Noise Control Requirements for Powerline Communications Channel, New Advanced Technologies, Aleksandar Lazinica (Ed.), ISBN: 978-953-307-067-4, InTech, Available from: <http://www.intechopen.com/books/new-advanced-technologies/residential-noise-control-requirements-for-powerline-communications-channel>

INTECH
open science | open minds

InTech Europe

University Campus STeP Ri
Slavka Krautzeka 83/A
51000 Rijeka, Croatia
Phone: +385 (51) 770 447
Fax: +385 (51) 686 166
www.intechopen.com

InTech China

Unit 405, Office Block, Hotel Equatorial Shanghai
No.65, Yan An Road (West), Shanghai, 200040, China
中国上海市延安西路65号上海国际贵都大饭店办公楼405单元
Phone: +86-21-62489820
Fax: +86-21-62489821

© 2010 The Author(s). Licensee IntechOpen. This chapter is distributed under the terms of the [Creative Commons Attribution-NonCommercial-ShareAlike-3.0 License](#), which permits use, distribution and reproduction for non-commercial purposes, provided the original is properly cited and derivative works building on this content are distributed under the same license.

IntechOpen

IntechOpen