

# We are IntechOpen, the world's leading publisher of Open Access books Built by scientists, for scientists

## 4,800

Open access books available

## 122,000

International authors and editors

## 135M

Downloads

Our authors are among the

## 154

Countries delivered to

## TOP 1%

most cited scientists

## 12.2%

Contributors from top 500 universities

**WEB OF SCIENCE™**Selection of our books indexed in the Book Citation Index  
in Web of Science™ Core Collection (BKCI)

## Interested in publishing with us? Contact [book.department@intechopen.com](mailto:book.department@intechopen.com)

Numbers displayed above are based on latest data collected.

For more information visit [www.intechopen.com](http://www.intechopen.com)

# Singularity-Based Calibration – A Novel Approach for Absolute-Accuracy-Enhancement of Parallel Robots

Philipp Last

*Siemens AG, Energy Sector, Power Distribution Division,  
Medium Voltage (E D MV C R&D 4)  
Germany*

Annika Raatz and Jürgen Hesselbach

*Technical University Braunschweig  
Institute of Machine Tools and Production Technology (IWF)  
Germany*

## 1. Introduction

Due to different reasons such as manufacturing and assembly errors, the real geometry of a robot manipulator usually deviates from that defined by the kinematic model which is used for robot control. As a consequence, the absolute accuracy of the robot is limited and offline generated robot programs cannot be executed with sufficient accuracy. With the help of robot calibration, these shortcomings can be overcome. The underlying concept is to estimate the parameters of the kinematic model based on redundant measurements. This data can be used to alter the kinematic model so that it matches the reality as closely as possible. This is ultimately used to correct the parameters in the controller model which thus improves the obtainable absolute accuracy.

This article covers a new and innovative approach for robot calibration which can be applied to parallel robots. In comparison to all known calibration techniques, this novel scheme has the advantage in that it does not rely on any additional calibration hardware. In addition to being cost effective, this method is simple to use as it can be completely automated.

The main aspect of the work at hand is an approach which allows the acquisition of redundant measurement-data required for calibration. Under consideration of special knowledge of the robot-structure's behaviour in certain configurations, so-called singularities of the second type, measurement information is gathered using the robot's actuator measurement systems only. The presented approach is thus denoted as singularity based calibration. In conjunction with qualified modelling and identification methods, the proposed measurement approach sets up a completely new robot calibration scheme. With

the exception of special cases, the proposed technique is principally applicable to all parallel kinematic structures.

The technique is first explained by means of a simple and comprehensible example. Subsequently successful implementation of the singularity-based calibration technique is exemplarily shown by practical experiments which are conducted on a parallel-robot with three degrees of freedom (dof), the so-called TRIGLIDE-robot system. The final results show that singularity based calibration is an adequate means to significantly improve a robot's absolute accuracy.

## 2. Kinematic Robot Calibration – Fundamental approach

The essential point in any robot calibration technique that follows the idea to replace the model parameters in the controller-model is to set up a residual of the form

$$r(\mathbf{k}) = \tilde{\mathbf{b}} - \mathbf{b}(\mathbf{k}) \quad (1)$$

with  $\tilde{\mathbf{b}}$  some redundantly measurement information,  $\mathbf{b}(\mathbf{k})$  a vector with corresponding information provided by the kinematic model and  $\mathbf{k}$  the parameter vector which is supposed to be identified. If such a residual can be obtained at  $n$  different measurement configurations then it is possible to stack all the information in a residual vector  $\mathbf{r}(\mathbf{k}) = [r_1^T, r_2^T, \dots, r_n^T]^T$ . Once this vector is available it is the goal to estimate the parameters in a way such that

$$\mathbf{r}(\mathbf{k}) = \mathbf{0} \quad (2)$$

Due to measurement noise and model simplifications this goal is, however, of theoretical nature and will never be exactly reached in reality. Instead one aims to minimize a cost function

$$F = \mathbf{r}^T(\mathbf{k})\mathbf{r}(\mathbf{k}) \quad (3)$$

which if  $\mathbf{r}(\mathbf{k}) = \mathbf{0}$  would be fulfilled equals zero as well and is otherwise bigger than zero. The minimization of  $F$  can be attained by any optimization method in principle. Usually, due to the special so-called least squares form of the function  $F$ , least-square algorithms such as the Levenberg-Marquardt approach (Scales, 1985) are applied. Minimization of  $F$  finally yields a parameter vector  $\mathbf{k}^{kalib}$  which is then used to replace the original parameters that were used before calibration within the robot-controller.

Considering the aforementioned remarks, four essential steps can be identified which are existent in each model-based calibration approach. These are (Mooring et al., 1991):

### 1. modelling

In the modelling phase a kinematic model is set up which includes a number of geometric parameters that are supposed to be identified by calibration

### 2. measurement

The measurement step provides the redundant information required for calibration

**3. parameter identification**

By means of feasible mathematical methods the model parameters are identified in a way so that model and measurements correspond to each other in a best possible manner

**4. parameter correction**

Within the parameter correction step the identified parameters are transferred to the robot controller

### 3. Classification of Calibration techniques

A huge number of calibration methods already exist which follow the general scheme described in the preceding section. Differences between these techniques can be found in various aspects at different stages. The most obvious and most important differences, however, exist in the measurement phase. Based on this appraisal a general classification can be defined for the different calibration strategies which includes the two separation criteria: First the degree of automation and second the data-acquisition method, both briefly explained in what follows.

- **degree of automation**

In regard to the degree of automation autonomous and non-autonomous calibration techniques are distinguished. A calibration method is understood to work autonomously only if all steps of the overall procedure can be completely automated and absolutely no user interaction is required during calibration. If any effort is needed for preparation, for accomplishment or data-transfer during calibration then the corresponding technique is defined to be non-autonomous.

It should be noted that the non-autonomous methods, although combined in one group, may drastically vary in the amount of required manual support.

- **data-acquisition method**

Two fundamental data-acquisition methods may be used for robot calibration. The first one uses additional sensors (internal or external) which are not required for operating the robot but just in order to provide redundant information. The second method relies on kinematic constraints that are introduced in the system without raising the number of sensors. In this case due to constraints the actuator measurement systems which are already part of the robot system deliver enough information for robot calibration.

In combination of all possible classification attributes there are four principle types of calibration techniques, namely type A, type B, type C and type D (see Fig. 1). Whereas calibration methods of type A to type C are well established and intensively described in the literature (see Table 1), no methods of type D have been reported so far up to the authors knowledge. This gap is closed by the singularity based calibration strategy presented in this paper and in preliminary work (Last & Hesselbach, 2006; Last et al., 2006, Last et al., 2007a, Last et al., 2007b; O'Brien et al., 2007).

		data-aquisition method	
		by additional sensors	by kinematic constraints
degree of automation	non-autonomous	type A	type B
	autonomous	type C	type D

Fig. 1. Classification of robot calibration techniques

	exemplary approach	Source
Type A	<ul style="list-style-type: none"> <li>- Calibration by means of a lasertracker</li> <li>- Calibration by means of camera-systems</li> <li>- Calibration using a double-ball-bar</li> </ul>	(Corbel et al., 2006) (English et al., 2002)  (Beyer, 2004) (Nefzi et al., 2008)  (Huang et al., 2006) (Ibaraki et al., 2004) (Ihara et al., 2000) (Takeda et al., 2004)
Type B	<ul style="list-style-type: none"> <li>- Calibration by contour tracking</li> <li>- Calibration by passive joint clamping</li> </ul>	(Ikits & Hollerbach, 1997) (Legnani et al., 2001) (Vischer, 1996) (Zhuang et al., 1999)  (Maurine et al., 1998) (Khalil & Besnard, 1999)
Type C	<ul style="list-style-type: none"> <li>- Calibration by passive joint sensors</li> <li>- Calibration with actuation redundancy</li> </ul>	(Hesselbach et al., 2005a) (Last et al., 2005) (Zhuang, 1997)  (Schönherr, 2002) (Zhang et al., 2007)

Table 1. Exemplarily chosen calibration strategies of different type

## 4. Singularity Based Calibration

The new calibration approach contributed here relies on passing singularities of type 2. Because these constitute structure configurations where several solutions of the direct kinematic problem (DKP) coincide, they are also called direct kinematic singularities. It is well known that a robot-structure is uncontrollable in this kind of configurations (Hesselbach et al., 2005b) and hence particular strategies need to be applied to safely guide a manipulator through singularities of type 2. Such a technique is described in section 4.1. Within the same section it is also shown how some specific measurement information is obtained during that process. Subsequently in section 4.2 it will be shown how to compute corresponding information from the kinematic model.

### 4.1 Passing singularities of type 2 as the basis of singularity based calibration

With the intention of workspace enlargement Helm has been the first who presented a technique to pass singularities of type 2 (Helm, 2003). It was experimentally proven at a planar robot-structure. Later the approach has been extended to spatial parallel structures in (Budde et al., 2005). Both methods rely on the basic idea which consists in temporarily underactuation of the robot system during passing the singular configuration and to use an additional driving force to guide the structure through the direct kinematic singularity. By means of the planar RRRRR-structure the approach is exemplarily summarized in Fig 2. In a pose near the singular configuration (a) the structure is underactuated by releasing one actuator (b). While the second actuator is kept at a constant motor-position the endeffector-point C passes the singularity (c) driven by gravity influence until it reaches a non-singular configuration (d) in which the released actuator can be activated again. Instead of exploiting gravity as the driving force which has been also done in (Budde et al., 2005), structure inertia may be used to pass the singularity as described in (Helm, 2003).

Performing the singularity passing while holding the motor that is not released, at a constant position it turns out that the released actuator changes its direction of movement (see dashed line) exactly in the point of the singularity that is reached if both rod elements of the robot manipulator build a common line. Consequently by observing the movement of the released actuator by its own motor-encoder it is possible to identify and save the actuator coordinate  $\tilde{q}_{released}^{sing}$  of the released motor that corresponds to a singular configuration. Furthermore, since particular geometric conditions need to be fulfilled at a singular configuration of type 2, it is possible to compute the corresponding actuator coordinate  $q_{released}^{sing}(\mathbf{k})$  from the kinematic model including the kinematic parameters  $\mathbf{k}$ . Comparing both information leads to a residual

$$r(\mathbf{k}) = \tilde{q}_{released}^{sing} - q_{released}^{sing}(\mathbf{k}) \quad (4)$$

corresponding to that in equation (1) which is the basis for singularity based calibration. Once such a residual can be conducted at a sufficiently high number of differing robot configurations the singularity based calibration procedure proceeds as described in section 2.

What is important to mention at this point is that the method is general for parallel robots and does not only apply to the RRRRR-structure. Independent on the robot structure a change of direction of the released actuator can be observed if a type 2 singularity is passed

while keeping all other actuators of the manipulator to be calibrated at a constant position during that approach. An application to serial robots is impossible because type 2 singularities only occur for parallel robots.

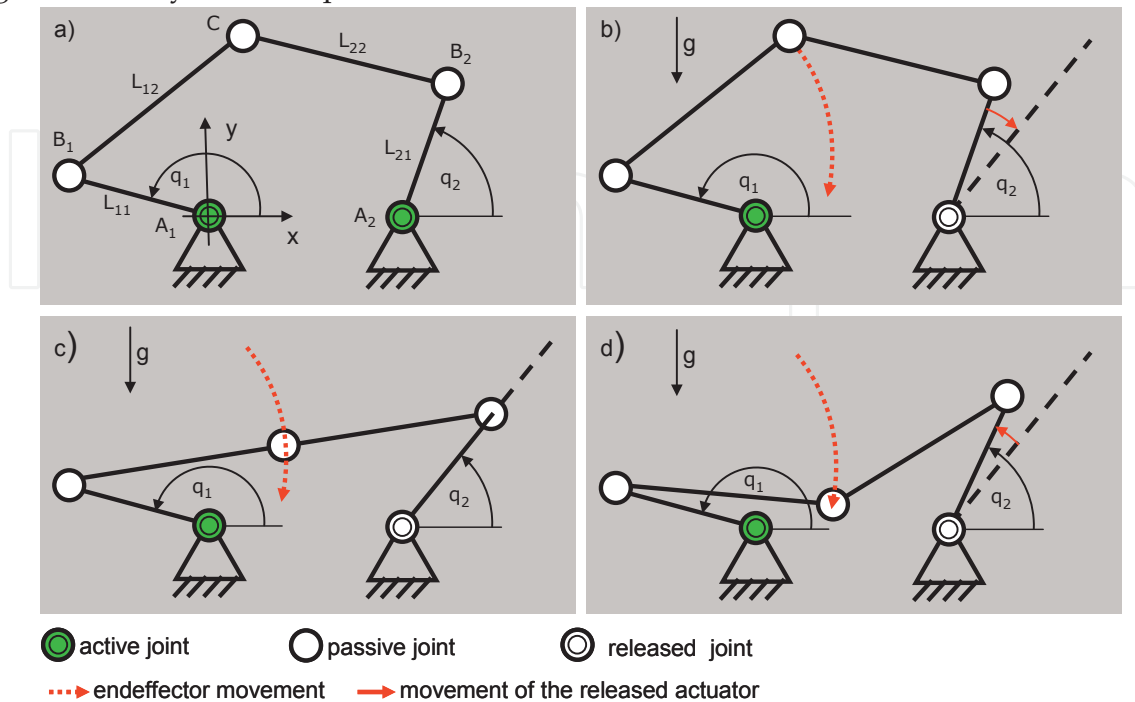

Fig. 2. Passing a singularity of type 2

#### 4.2 Singular kinematic problem

In the preceding section it was assumed that the actuator coordinate  $q_{released}^{sing}(\mathbf{k})$  which ideally corresponds to the measured value  $\tilde{q}_{released}^{sing}$  can be computed from the kinematic model. Indeed this computation which is denoted as singular kinematic problem (SKP) is straightforward for the  $\underline{RRRRR}$ -manipulator because due to the simple kinematic structure an analytic solution exists. However, a closed form SKP-solution is not the general case. For more complex structures iterative numerical solutions need to be applied. Thus, in order to allow for a wide application of the singularity based calibration approach a general SKP-solution strategy is presented in this section.

A requirement for the application of the general SKP-solution-technique consists in a valid solution for the DKP that does not cause any numerical problems in or near singularities. Techniques which provide such a solution are presented in (Wang & Chen, 1991) and in (Last et al. 2007). Both methods follow an iterative numeric procedure and both methods return a loop closure error  $E_{total}$  with a clear geometrical meaning (see Fig. 3 (left)) that is zero if a valid DKP-solution exists and bigger than zero if no DKP-solution can be found.

The proposed SKP-solution exploits the fact that type 2 singularities define the boundary of the actuator space for parallel manipulators. This means that, when varying the released actuator coordinate  $q_{released}$  away from the singular value  $q_{released}^{sing}$ , DKP solutions are found when moving  $q_{released}$  in one direction while no DKP solutions are found when moving  $q_{released}$  in the opposite direction. Without loss of generality this behaviour is illustrated in Fig. 3 for the the  $\underline{RRRRR}$  manipulator. Fig. 3 (left) shows the manipulator in

three different situations. Situation B constitutes a “normal” configuration within the manipulator’s actuator. In situation A, it is not possible to connect the loops of the mechanism, causing the DKP-solution to converge to an error  $E_{total} > 0$ . Hence the actuator position is not valid. Finally, a singular configuration is shown as situation S. A corresponding plot showing the loop-closure-error  $E_{total}$  vs. the released actuator value  $q_{released}$  is illustrated in Fig. 3 (right). Obviously, for situation A, the DKP error  $E_{total}$  is greater than zero, while it holds that  $E_{total} = 0$  for situation B. The singular situation corresponds to the value  $q_{released}$  for which  $E_{total}$  starts deviating from zero. Based on the aforementioned observations, a simple bisection search can be applied to find  $q_{released} = q_{released}^{sing}$ . Its basic idea is to successively reduce an interval from which it is known that it includes  $q_{released}^{sing}$ . The method can be summarized as follows:

- 1) Provide an actuator value  $q_{released}^A$  outside the workspace and a second actuator value  $q_{released}^B$  inside the actuator space, both defining the initial search interval. Specify a termination threshold  $\varepsilon_{q,diff}$  close to but bigger than zero, which defines the size of the search interval at which the algorithm terminates.
- 2) Compute an actuator coordinate  $q_{released}^C$  located in the middle of  $q_{released}^A$  and  $q_{released}^B$
- 3) Solve the direct kinematics for  $q_{released} = q_{released}^C$ , thereby obtaining a loop closure error  $E_{total}(q_{released}^C)$ .
- 4) If  $E_{total}(q_{released}^C) > 0$  (to account for numerical deviations a value very close to but bigger than zero can be chosen instead of zero), then  $q_{released}^A = q_{released}^C$ , otherwise  $q_{released}^B = q_{released}^C$ .
- 5) If the difference  $q_{released}^B - q_{released}^A > \varepsilon_{q,diff}$ , repeat from step 3, otherwise terminate with  $q_{released}^{sing} = q_{released}^B$ .

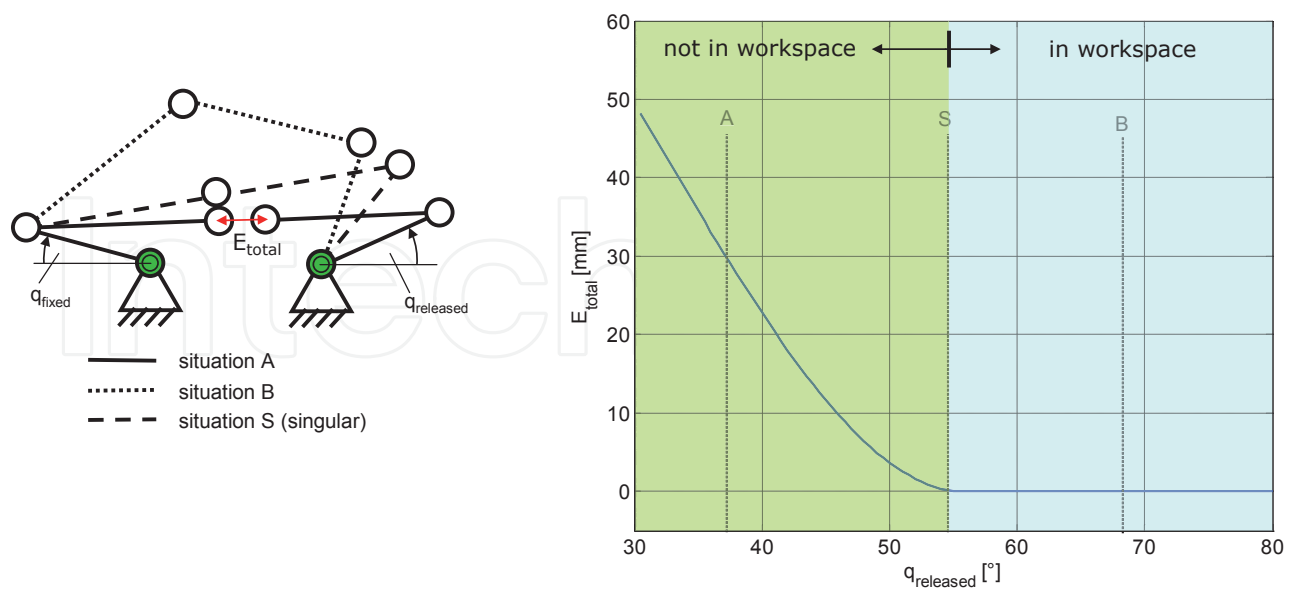

Fig. 3. Singularity as the boundary of the actuator space



### 4.3 Summary and review

The ideas presented in section 4.1 and in section 4.2 define the fundamental basis of the singularity based calibration. In conjunction with a suited modelling approach and an adequate parameter identification procedure (both described in the wide spread literature on robot calibration) the proposed methods build a general means to improve the absolute accuracy of parallel robot systems. In comparison to alternative techniques for robot calibration (type C - type singularity based calibration does neither rely on additional sensors (external or internal) nor requires the use of special hardware to constrain the robot motion. Due to the abandonment of particular calibration equipment singularity based calibration features the advantages of being cost effective and at the same time fully automatable. According to (Hidalgo & Brunn, 1998) these are aspects which are crucial for success of a calibration approach.

## 5. Application to the TRIGLIDE robot system

In order to validate the singularity based calibration method it is tested on a certain robot, the so-called TRIGLIDE structure (see Fig. 4) designed for high-speed handling and assembly tasks (Budde, 2007). Three equally designed kinematic chains connect the endeffector-platform of this robot with the base platform. Each chain is actuated by a linear drive. Due to the use of two parallel rods in the build-up of the three chains, the endeffector-platform is always kept at constant orientation. This fully parallel structure has three degrees of freedom allowing for free positioning of the endeffector in space. By attaching a serial rotational axis to the platform, an additional rotation around the z-axis can be accomplished, thus enabling the robot to perform Scara-type movements. Since the rotational axis is irrelevant to the calibration approach discussed here, it is neglected in the following.

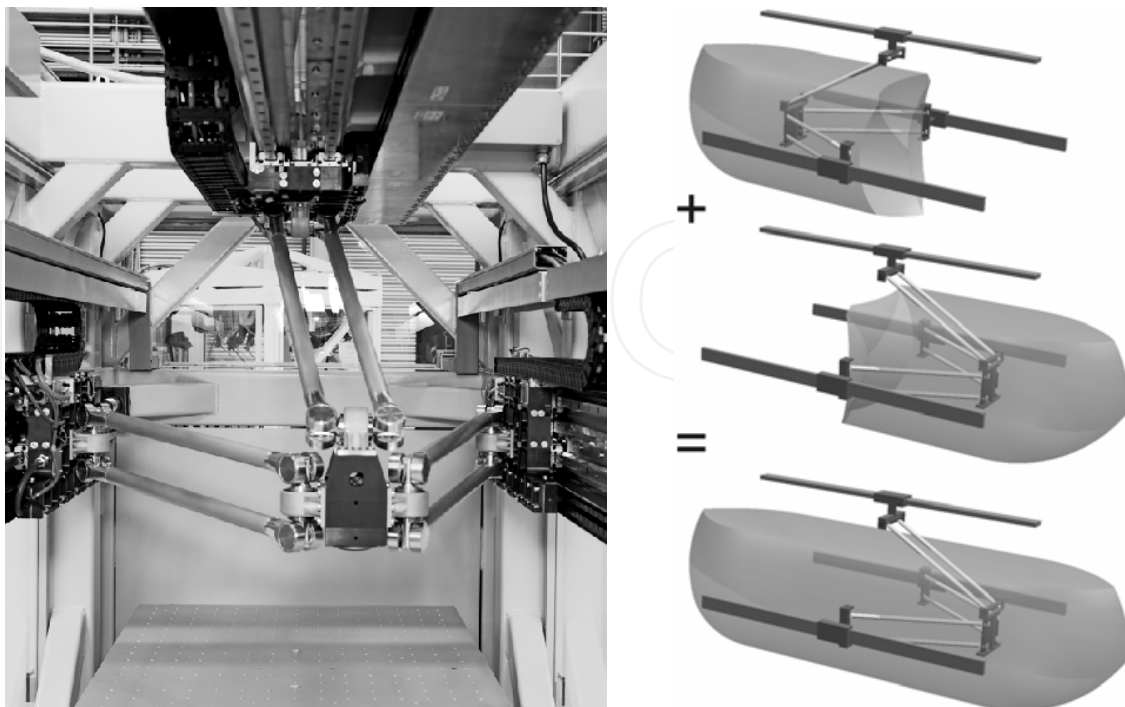

Fig. 4. TRIGLIDE robot system (left) and corresponding workspaces (right)

### 5.1. Passing Singularities

As stated above, singularity based calibration requires passing singularities of type 2. The proposed technique to realize such a passing (see section 4.1) has been successfully implemented on the TRIGLIDE structure – again with the original intention to enlarge its workspace. As can be seen in Fig. 4 (right) it allows to combine two symmetrical workspaces to an overall workspace which is almost twice as big as the single workspaces. Both of these workspaces are not diminished by direct kinematic singularities within them, allowing for their complete utilization. However, the transition between these two workspaces requires, that several singularities have to be passed and several other workspaces have to be crossed. Each of the workspaces corresponds to a specific working mode, also called IKP-configuration, where an IKP-configuration is characterized as follows: For a given position of the platform there are two possible positions of the carriage in each of the three kinematic chains  $i = 1,2,3$  which will be described as  $K_{IKP,i} = \{-1, +1\}$ . They correspond to different solutions of the inverse kinematic problem. With this definition a complete IKP-configuration can be uniquely described using the vector  $\mathbf{K} = [K_{IKP,1}, K_{IKP,2}, K_{IKP,3}]$ . The two workspaces, the robot is going to be used in (Fig. 4) are based on the IKP-configurations  $[-1, -1, -1]$  and  $[+1, +1, +1]$  and are called the two working configurations. To switch between them several transition workspaces have to be passed. Due to the multitude of transition configurations there are several possibilities finding a way from one working configuration to the other one, of which one path is shown in Fig. 5 (a)-(d). In addition to the configurations to be passed, corresponding workspace sections parallel to the y-z-plane are shown in the figures.

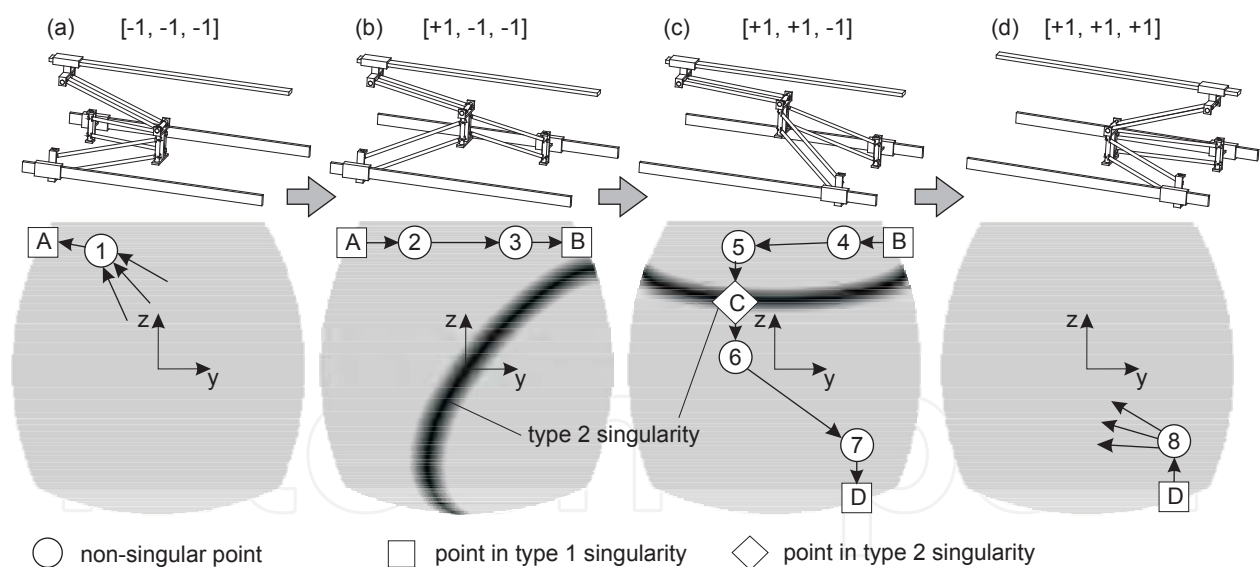

Fig. 5. Changing the working configuration

The total approach to switch between the two working configurations is explained in (Budde et al., 2008) and in (Budde, 2009) in more detail. For the calibration approach it is most essential to pass the singularity of type 2. Hence we focus on Fig. 5 (c) which shows the crossing of a type two singularity in position C. Similarly to the procedure described in section 4.1 the approach is as follows. First the endeffector is placed above the singularity (position 5) depicted by the black line within the workspace. At this point the robot system is underactuated by releasing the upper actuator. Forcing the other two actuators to remain

at a constant position, the endeffector driven by gravity starts moving on a circular path. It passes the type 2 singularity in position C and finally reaches a non singular position 6 in which the released actuator can be activated again. Due to the temporary underactuation of the system, the risk of damage is avoided and the endeffector can reliably travel through the singularity. As for the simple manipulator shown above it becomes apparent that the released actuator changes its direction of movement exactly in the point of the singularity, thus allowing for experimental singularity detection. In the description of the proposed approach a particular IKP-configuration was chosen for passing direct kinematic singularities in the workspace of the TRIGLIDE robot and the upper actuator was released. In the same manner also one of the other actuators could have been released with the two remaining motors locked at the same time. Moreover, the singularity of type 2 not necessarily needs to be passed in the depicted position. Indeed, because the singularity builds a continuous surface in space (figure 3), it is possible to cross it at different positions even in other IKP-configurations and to collect enough information in order to allow for a complete calibration of the TRIGLIDE robot.

## 5.2 Experimental results

With the working configuration change procedure available as a robot command, singularity based calibration has been implemented on the TRIGLIDE robot system in a way so that calibration can be completely automatically performed. This means that once a special robot program is executed the whole calibration process is started and runs without a need for user interaction. First tests prove the principal functionality of the technique, however, it turns out that the absolute accuracy reached by the method is not sufficiently good. A critical review makes us believe that this is mainly due to elastic structure deformations occurring during singularity passing which finally result in disturbed measurement data. As a remedy the implementation is changed in a way that the singularity passing process is manually supported. By this means dynamics during singularity passing is significantly reduced thereby decreasing elastic deformation influence. Indeed, by this means the results can be drastically improved.

A typical calibration result is depicted in Fig. 6. It shows the position error, which is the difference between a computed and a measured target position at 125 equally distributed control configuration in each of the two working configurations  $[+1 +1 +1]$  and  $[-1 -1 -1]$  of the robot. The real position is measured by means of a Leica-lasertracker system while the computation of a corresponding value is accomplished by the DKP-solution as a function of the measured motor coordinates. As can be seen by the results, the initial accuracy of the robot is already quite good with maximum positioning deviations of approx. 0.6 mm. However the accuracy can be significantly improved by the proposed singularity based calibration method so that the remaining absolute positioning error after calibration is approx. 0.36 mm in maximum. Mean value as well as the standard deviation of the positioning error over the 250 control configurations also take better values after calibration compared to the uncalibrated case.

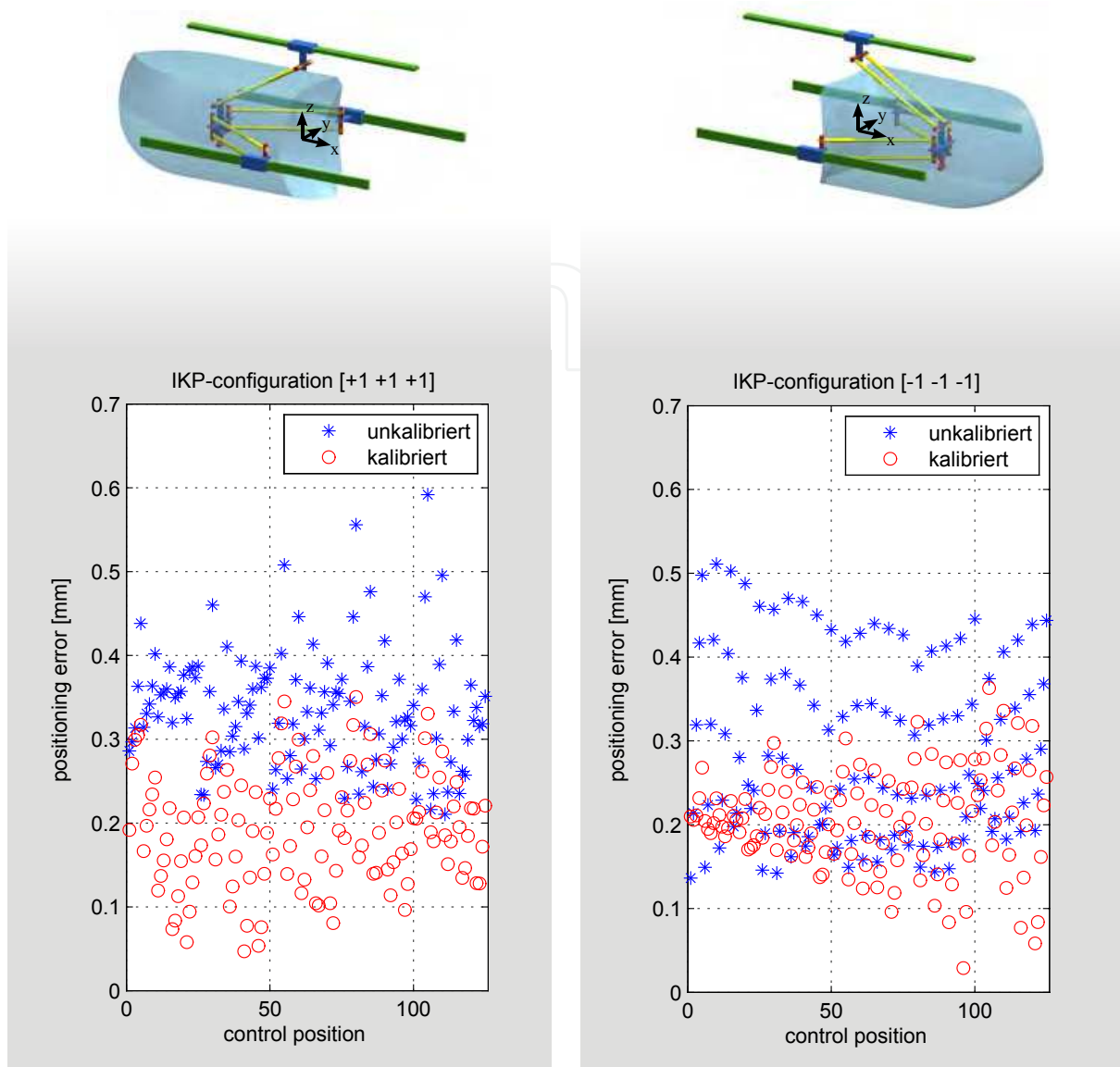

Fig. 6. positioning error at each control position of the validation routine.

## 6. Conclusion

For the first time a robot calibration approach has been presented that does exclusively rely on the information delivered by the robot-system itself. Hence, as neither additional sensors nor special constraint devices are required in order to apply parameter identification methods, the proposed technique is very economical and easy to use. It is thus especially convenient to be used in small and medium sized companies which do neither own special robot calibration equipment nor have professional skilled robot calibration experts. The basic idea of the new calibration scheme has been explained from a theoretical point of view by means of a simple example structure and subsequently validated through experiments by means of a more complex spatial parallel structure. The obtained results emphasize the promising potential of the approach.

## 7. Acknowledgements

The research work reported here was supported by the German Reserach Foundation (DFG) within the scope of the Collaborative Research Center SFB 562.

## 8. References

- Beyer, L. (2004). Genauigkeitssteigerung von Industrierobotern - insbesondere mit Parallelkinematik, Helmut Schmidt Universität Hamburg, Dissertation
- Budde, C.; Kolbus, M.; Last, P.; Raatz, A.; Hesselbach, J.; Schumacher, W. (2008). Optimized Change of Working and Assembly Mode of the SFB 562 TRIGLIDE-Robot, Proceedings of the 3rd International Colloquium of the SFB 562: Robotic Systems for Handling and Assembly (RSHA 2008), pp. 221-236, Braunschweig (Germany), Shaker Verlag, Aachen
- Budde, C.; Last, P.; Hesselbach, J. (2007). Development of a Triglide-Robot with Enlarged Workspace. Proceedings of the IEEE International Conference on Robotics and Automation, Rome (Italy), pp. 543-548
- Budde, C. (2009). Wechsel der Konfiguration zur Arbeitsraumvergrößerung bei Parallelrobotern, Technische Universität Braunschweig, Vulkan-Verlag, Dissertation
- Corbel, D.; Company, O.; Nabat, V.; Maurine, P. (2006). Geometrical Calibration of the High Speed Robot Par4 using a Laser Tracker. Proceedings of the 12th IEEE International Conference on Methods and Models in Automation and Robotics, pp. 687-692
- English, K.; Hayes, M.J.D.; Leitner, M.; Sallinger, C. (2002). Kinematic Calibration of Six-Axis Robots. Proceedings of the CSME Forum, Kingston (Canada)
- Helm, M. B. (2003). Durchschlagende Mechanismen für Parallelroboter, Technische Universität Braunschweig, Vulkan Verlag, Dissertation
- Hesselbach, J.; Bier, C.; Budde, C.; Last, P.; Maaß, J.; Bruhn, M. (2005). Parallel Robot Specific Control Functionalities. Proceedings of the 2nd International Colloquium of the SFB 562: Robotic Systems for Handling and Assembly (RSHA 2005). Braunschweig (Germany), pp. 93-108
- Hesselbach, J.; Bier, C.; Campos, A.; Löwe, H. (2005). Direct Kinematic Singularity Detection of a Hexa Parallel Robot, Proceedings of the IEEE International Conference on Robotics and Automation, Barcelona (Spain), pp. 3507-3512
- Hidalgo, F.; Brunn, P. (1998). Robot Metrology and Calibration Systems - A Market Review. *Industrial Robot: An International Journal* Vol. 25, No. 1, pp. 42-47
- Huang, T.; Hong, Z.Y.; Mei, J.P.; Chetwynd, D.G. (2006). Kinematic Calibration of the 3-DOF Module of a 5-DOF Reconfigurable Hybrid Robot using a Double-Ball-Bar System. Proceedings of the IEEE/RSJ International Conference on Intelligent Robots and Systems, Peking (China), 2006, pp. 508-512
- Ibaraki, S.; Yokawa, T.; Kakino, Y.; Nakagawa, M.; Matsushita, T. (2004). Kinematic calibration on a parallel kinematic machine tool of the Stewart platform by circular tests. Proceedings of the American Control Conference, Boston (USA), pp. 1394-1399

- Ihara, Y.; Ishida, T.; Kakino, Y.; Li, Z.; Matsushita, T.; Nakagawa, M. (2000). Kinematic Calibration of a Hexapod Machine Tool by Using Circular Test. Proceedings of the 2000 JAPAN-USA Symposium on Flexible Automation, Ann Arbor (USA)
- Ikits, M.; Hollerbach, J.M. (1997). Kinematic calibration using a plane constraint. Proceedings of the IEEE International Conference on Robotics and Automation, Albuquerque (USA), pp. 3191–3196
- Khalil, W.; Besnard, S. (1999). Self Calibration of Stewart-Gough Parallel Robots Without Extra Sensors. IEEE Transactions on Robotics and Automation, Vol. 15, Nr. 6, pp. 1116–1121
- Last, P.; Budde, C.; Hesselbach, J. (2005). Self-Calibration of the HEXA-Parallel-Structure. Proceedings of the IEEE International Conference on Automation Science and Engineering (CASE), Edmonton (Canada), pp. 393–398
- Last, P.; Raatz, A.; Carretero, J.-A.; O'Brien, S. M. (2007). A General Approach to Solve the Singular Kinematic Problem, Proceedings of the IEEE/RSJ International Conference on Intelligent Robots and Systems (IROS), San Diego, CA, USA
- Last, P.; Hesselbach, J. (2006). A new calibration strategy for a class of parallel mechanisms, Advances in Robot Kinematics (ARK) - Mechanisms and Motion, Springer Verlag, Berlin, pp. 331–338
- Last, P.; Budde, C.; Krefft, M.; Hesselbach, J. (2006). Parallel Robot Self-Calibration Without Additional Sensors or Constraint Devices, Proceedings of the ISR/Robotik, München
- Last, P.; Gaggiotto, F.; Budde, C.; Raatz, A. (2007) Optimal Selection of Measurement Configurations for Singularity Based Calibration of Parallel Kinematic Robots. Proceedings of the IEEE/ASME Conference on Advanced and Intelligent Machines (AIM), Zurich (Switzerland)
- Last, P.; Schütz, D.; Raatz, A.; Hesselbach, J. (2007). Singularity Based Calibration of 3-DOF Fully Parallel Planar Manipulators. Proceedings of the 12<sup>th</sup> IFToMM World Congress, Besancon (Frankreich)
- Legnani, G.; Adamini, R.; Jatta, F. (2001). Calibration of a Scara Robot by Force-Controlled Contour Tracking. Proceedings of the 32nd International Symposium on Robotics, Seoul (South Korea)
- Maurine, P.; Liu, D. M.; Uchiyama, M. (1998). Self Calibration of a New Hexa Parallel Robot. Proceedings of the 4th Japan-France Congress and 2nd Asia-Europe Congress on Mechatronics, Kitakyushu (Japan), pp. 290–295
- Mooring, B. W.; Roth, Z. S.; Driels, M. R. (1991). Fundamentals of Manipulator Calibration, John Wiley and Sons INC.
- O'Brien, S. M.; Carretero, J.-A.; Last, P. (2007) Self Calibration of 3-PRS Manipulator Without Redundant Sensors, Transactions of the Canadian Society for Mechanical Engineering, Vol. 31, No. 4, pp. 483–494
- Scales, L. E. (1985). Introduction to Non-Linear Optimization. Macmillan Publishers Ltd.
- Schönherr, J. (2000). Zur Selbstkalibrierung von Parallelmanipulatoren. Proceedings of the 2nd Chemnitz Parallel Kinematics Seminar, Chemnitz (Germany), pp. 113–123
- Y.Takeda; Shen, G.; Funabashi, H. (2004). A DBB-Based Kinematic Calibration Method for In Parallel Actuated Mechanisms Using a Fourier Series. Journal of Mechanical Design, Vol. 126, Nr. 5, pp. 856–865

- Vischer, P. (1996). Improving the Accuracy of Parallel Robots, Ecole Polytechnique Federale de Lausanne, Dissertation
- Zhang, Y.; Cong, S.; Li, Z.; Jiang, S. (2007). Auto-calibration of a redundant parallel manipulator based on the projected tracking error. *Archive of Applied Mechanics*, Vol. 77, Nr. 10, pp. 697-706
- Zhuang, H.; Motaghedi, S. H.; Roth, Z. S. (1999). Robot Calibration With Planar Constraints. *Proceedings of the IEEE International Conference on Robotics and Automation*, Detroit (USA), pp. 805-810
- Zhuang, H. (1997). Self-Calibration of Parallel Mechanisms with a Case Study on Stewart Platforms. *IEEE Transactions on Robotics and Automation*, Vol. 13, Nr. 3, pp. 387-397

IntechOpen



## **Robot Manipulators New Achievements**

Edited by Aleksandar Lazinica and Hiroyuki Kawai

ISBN 978-953-307-090-2

Hard cover, 718 pages

**Publisher** InTech

**Published online** 01, April, 2010

**Published in print edition** April, 2010

Robot manipulators are developing more in the direction of industrial robots than of human workers. Recently, the applications of robot manipulators are spreading their focus, for example Da Vinci as a medical robot, ASIMO as a humanoid robot and so on. There are many research topics within the field of robot manipulators, e.g. motion planning, cooperation with a human, and fusion with external sensors like vision, haptic and force, etc. Moreover, these include both technical problems in the industry and theoretical problems in the academic fields. This book is a collection of papers presenting the latest research issues from around the world.

### **How to reference**

In order to correctly reference this scholarly work, feel free to copy and paste the following:

Philipp Last (2010). Singularity-Based Calibration – A Novel Approach for Absolute-Accuracy Enhancement of Parallel Robots, Robot Manipulators New Achievements, Aleksandar Lazinica and Hiroyuki Kawai (Ed.), ISBN: 978-953-307-090-2, InTech, Available from: <http://www.intechopen.com/books/robot-manipulators-new-achievements/singularity-based-calibration-a-novel-approach-for-absolute-accuracy-enhancement-of-parallel-robots>

**INTECH**  
open science | open minds

### **InTech Europe**

University Campus STeP Ri  
Slavka Krautzeka 83/A  
51000 Rijeka, Croatia  
Phone: +385 (51) 770 447  
Fax: +385 (51) 686 166  
[www.intechopen.com](http://www.intechopen.com)

### **InTech China**

Unit 405, Office Block, Hotel Equatorial Shanghai  
No.65, Yan An Road (West), Shanghai, 200040, China  
中国上海市延安西路65号上海国际贵都大饭店办公楼405单元  
Phone: +86-21-62489820  
Fax: +86-21-62489821



© 2010 The Author(s). Licensee IntechOpen. This chapter is distributed under the terms of the [Creative Commons Attribution-NonCommercial-ShareAlike-3.0 License](#), which permits use, distribution and reproduction for non-commercial purposes, provided the original is properly cited and derivative works building on this content are distributed under the same license.

IntechOpen

IntechOpen