

We are IntechOpen, the world's leading publisher of Open Access books Built by scientists, for scientists

4,800

Open access books available

122,000

International authors and editors

135M

Downloads

Our authors are among the

154

Countries delivered to

TOP 1%

most cited scientists

12.2%

Contributors from top 500 universities

**WEB OF SCIENCE™**Selection of our books indexed in the Book Citation Index
in Web of Science™ Core Collection (BKCI)

Interested in publishing with us? Contact book.department@intechopen.com

Numbers displayed above are based on latest data collected.

For more information visit www.intechopen.com

Stiffness Analysis for an Optimal Design of Multibody Robotic Systems

Carbone Giuseppe

LARM: Laboratory of Robotics and Mechatronics, University of Cassino

Via G. Di Biasio, 43 – 03043 Cassino (Fr)

Italy

1. Introduction

Robots are widely used to help human beings and/or to execute various manipulative tasks in industrial applications and even in non-industrial environments. Researchers are still widely investigating robotics with the aim to further improve a robot performance and/or to enlarge their fields of application. These tasks can be achieved only when the peculiarities in Kinematics and Dynamics behaviors are properly considered since the early design stage. Significant works on the topics can be considered the pioneer papers (Shimano & Roth, 1978), (Vijaykumar et al., 1986), (Paden & Sastry 1988), (Manoochehri & Seireg 1990), and more recently the papers (Angeles 2002), (Hao & Merlet, 2005), (Carbone et al. 2007), just to cite a few references in a very rich literature. Algorithms have been proposed, for example, as based on workspace characteristics (Schonherr, 2000), and global isotropy property (Takeda, & Funabashi, 1999), separately. Several (often conflicting) criteria can be taken into account in the design process. Only recently, it has been possible to consider simultaneously several design aspects in design procedures for manipulators. Multi-criteria optimal designs have been proposed for example in (Ottaviano & Carbone 2003), (Hao & Merlet, 2005).

The significance of each design criterion is often strongly related with specific application task(s) and constraints. Therefore, in this chapter several design criteria are overviewed with specific numerical evaluation procedures for analytical definition of design optimization problems. But, among the design criteria special attention is addressed to stiffness, since it can be considered of primary importance in order to guarantee the successful use of any robotic system for a given task (Ceccarelli, 2004). Indeed, there are still open problems related with stiffness. Still an open issue can be considered, for example, the formulation of computationally efficient algorithms that can give direct engineering insight of the design parameter influence on stiffness response. There is also lack of a standard procedure for the comparison of stiffness performance for different multibody robotic architectures. Therefore, this chapter is also an attempt to propose a formulation for a reliable determination and comparison of the stiffness performance of multibody robotic systems by means of proper local and global stiffness performance indices. Then, the proposed numerical procedure is included into a multi-objective optimal design procedure, whose solution(s) can be achieved

even by taking advantage of solving techniques in commercial software packages. Illustrative examples are reported, also with the aim to clarify the computational efforts.

2. The optimal design problem and its formulation

The design problem for manipulators consists in several phases. The first phase is the type synthesis. In this phase a designer should select the type of kinematic architecture that can provide the desired stiffness, mobility, force, efficiency, size. For example, the architecture can be chosen as open chain or parallel structure, Fig.1. In addition, different solutions can be selected within each structure as depending on manipulative tasks.

After the type synthesis one should perform a dimensional synthesis aiming to compute values of design parameters that characterize and size the kinematic structure of a manipulator. Several aspects can be considered in a design procedure at this stage in order to achieve suitable performance for the desired application tasks.

Often performance improvements can be obtained from the point of view of a design criterion at the cost of worst performance in terms of other design criteria. Thus, it is very useful to develop computer aided procedures that can attempt to provide a design solution by considering more than one design criterion at the same time.

An optimization problem can be formulated in a very general form as

$$\min F(\mathbf{X}) \quad (1)$$

subject to

$$\begin{aligned} \mathbf{G}(\mathbf{X}) &\leq 0 \\ \mathbf{H}(\mathbf{X}) &= 0 \end{aligned} \quad (2)$$

where \mathbf{X} is the vector whose components are the design parameters; F is the objective function vector, whose components are the expressions of mobility criteria. $\mathbf{G}(\mathbf{X})$ is the vector of inequality constraint functions that describes limiting conditions. $\mathbf{H}(\mathbf{X})$ is the vector of equality constraint functions that describes design prescriptions.

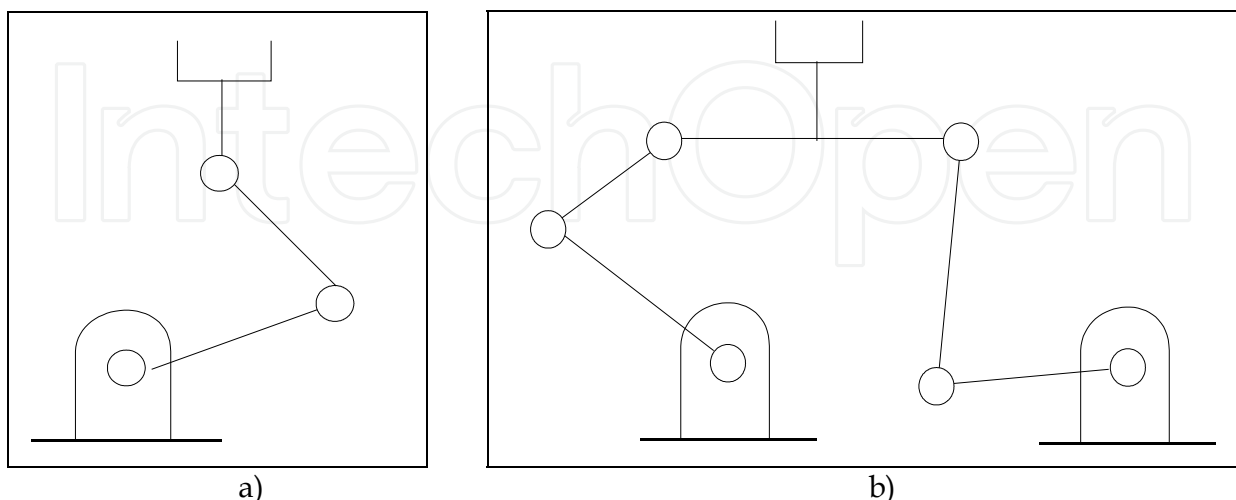

Fig. 1. Planar examples of kinematic chains of manipulators, (Ceccarelli, 2004): a) serial chain as open type; b) parallel chain as closed type.

In general, the design parameters \mathbf{X} in Eq.(1) are the sizes and mobility angles of manipulators architectures. Referring to Eq.(1), the main design issue is to properly define the objective function $F(\mathbf{X})$ so that it can express the design criteria that have to be optimized in a computationally efficient form. Equation (1) can be modified to consider several design criteria, for example, by using a weighted sum such as

$$\min_{\mathbf{x}} \left[\sum_i w_i F_i(\mathbf{X}) \right] \quad (3)$$

where F_i is the mathematical expression of the i -th objective function; w_i is the i -th weight coefficient. The weighted sum in Eq.(3) has two main limits. The first limit of the weighted sum approach is related with the choice of numerical value for the weight coefficients w_i . In fact, even small changes in the weight coefficients w_i will lead to different results. Then, the choice of weight coefficient should be done according to the experience of a designer to a specific application. The second limit of the weighted sum approach is that a minimization of the weighed sum objective function does not guarantee that any of the objective function is minimized. Thus, one has no guarantee that the solution of the optimization process will lead to an optimal design solution from the point of view of any design criterion.

Another possible formulation for Eq.(1) can be

$$\min_{\mathbf{X}} [F(\mathbf{X})] = \min_{\mathbf{X}} \left\{ \max_{i=1, \dots, N} [f_i(\mathbf{X})] \right\} \quad (4)$$

where \min is the operator for calculating the minimum of a vector function $F(\mathbf{X})$; similarly \max determines the maximum value among the N functions $[w_i f_i(\mathbf{X})]$ at each iteration; $\mathbf{G}(\mathbf{X})$ is the vector of constraint functions that describes limiting conditions, and $\mathbf{H}(\mathbf{X})$ is the vector of constraint functions that describes design prescriptions; \mathbf{X} is the vector of design variables. The proposed optimization formulation uses the objective function $F(\mathbf{X})$ at each iteration by choosing the worst-case value among all the scalar objective functions for minimizing it in the next iteration, as outlined in (Grace, 2002), (Mathworks, 2009). In particular, the worst-case value is selected in Eq.(4) at each iteration as the objective function with maximum value among the N available objective functions. This approach for solving multi-objective problems with several objective functions and complex tradeoffs among them is known as "minimax method", (Mathworks, 2009). The "minimax method" is widely indicated in the literature for many problems, like for example for estimating model parameters by minimizing the maximum difference between model output and design specification, (Pankov et al., 2000), (Eldar, 2006).

Optimal design of manipulators can be also formulated the form

$$\min_{\mathbf{X}} [F(\mathbf{X})] = \min_{\mathbf{X}} \left\{ \max_{i=1, \dots, N} [w_i f_i(\mathbf{X})] \right\} \quad (5)$$

In this case, weighting factors w_i (with $i=1, \dots, N$) have been used in order to scale all the objective functions. In particular, weighting factors w_i are chosen so that each product w_i

$f_i(X)$ is equal to one divided by N for an initial guess of a design case. The above-mentioned conditions on the objective functions can be written in the form

$$\sum_{i=1}^N (w_i f_i)_0 = 1 \quad (6)$$

$$N(w_i f_i)_0 = 1 \quad (7)$$

where the subscript 0 indicates that the values are computed at an initial guess of the design case. Bigger/lower weighting factors can be chosen in order to increase/reduce the significance of an optimal criterion with respect to others.

Main aspects of the numerical procedure to solve the proposed multi-objective optimization are described in the flowchart of Fig. 2. The first step in the optimization process consists of selecting the design variables, which in this manuscript correspond to geometrical properties such as robot link lengths and equivalent areas. Then, robot constraints, and upper and lower limits of design variables must be identified. In this process, preliminary data on the kinematics and physical properties of the robot are needed in order to obtain computationally efficient expressions for the objective functions. In addition, the weighting factors have to be assumed as based also on the initial guess design variables that are used for the normalization process. On the other hand, the numerical minimax technique minimizes the worst-case value of a set of multivariable functions, starting at an initial estimate (vector X_0). The minimax technique uses SQP (Sequential Quadratic Programming) to choose a merit function for the line search. The MATLAB SQP implementation consists of three main stages: Updating of the Hessian matrix of the Lagrangian function, Quadratic Programming problem Solution (QPS) and Line search and merit function calculation. First and second stages are explained in (Mathworks, 2009), the result of the QPS produces a vector Ψ_k which is used to obtain a new iteration ($X_{k+1} = X_k + \Psi_k \delta_k$). The step length parameter δ_k is determined in order to produce a sufficient decrease in a merit function. The new design parameter value is used to compute again the normalized objective functions that are used to check if the objective functions reach an optimal solution and fulfil the constraints. In this case the algorithm stops with an optimal solution. Otherwise, the loop starts again with a new iteration, as shown in Fig. 2.

Other search methods such as interval analysis (Merlet, 2004) can be also effectively used for an optimal design algorithm. Nevertheless, they have often too high computational costs. Therefore, numerical procedures are still widely used in optimisation processes even if they can suffer of known drawbacks. Some algorithms such as flooding techniques, simulated annealing, genetic algorithms can be faster in finding an optimal solution with a single objective function. But, they still cannot guarantee the convergence (Vanderplaats, 1984), (Branke 2008). Moreover, they cannot still guarantee that an optimal solution is a global optimum. In fact, one can be sure to reach a global optimum only for convex optimization problems (Boyd & Vandenberghe, 2004).

The formulation of the design problem as an optimization problem gives the possibility to consider contemporaneously several design aspects that can be contradictory for an optimal solution. Thus, optimality criteria are of fundamental interest even for efficient computations in solving optimization problems for manipulator design.

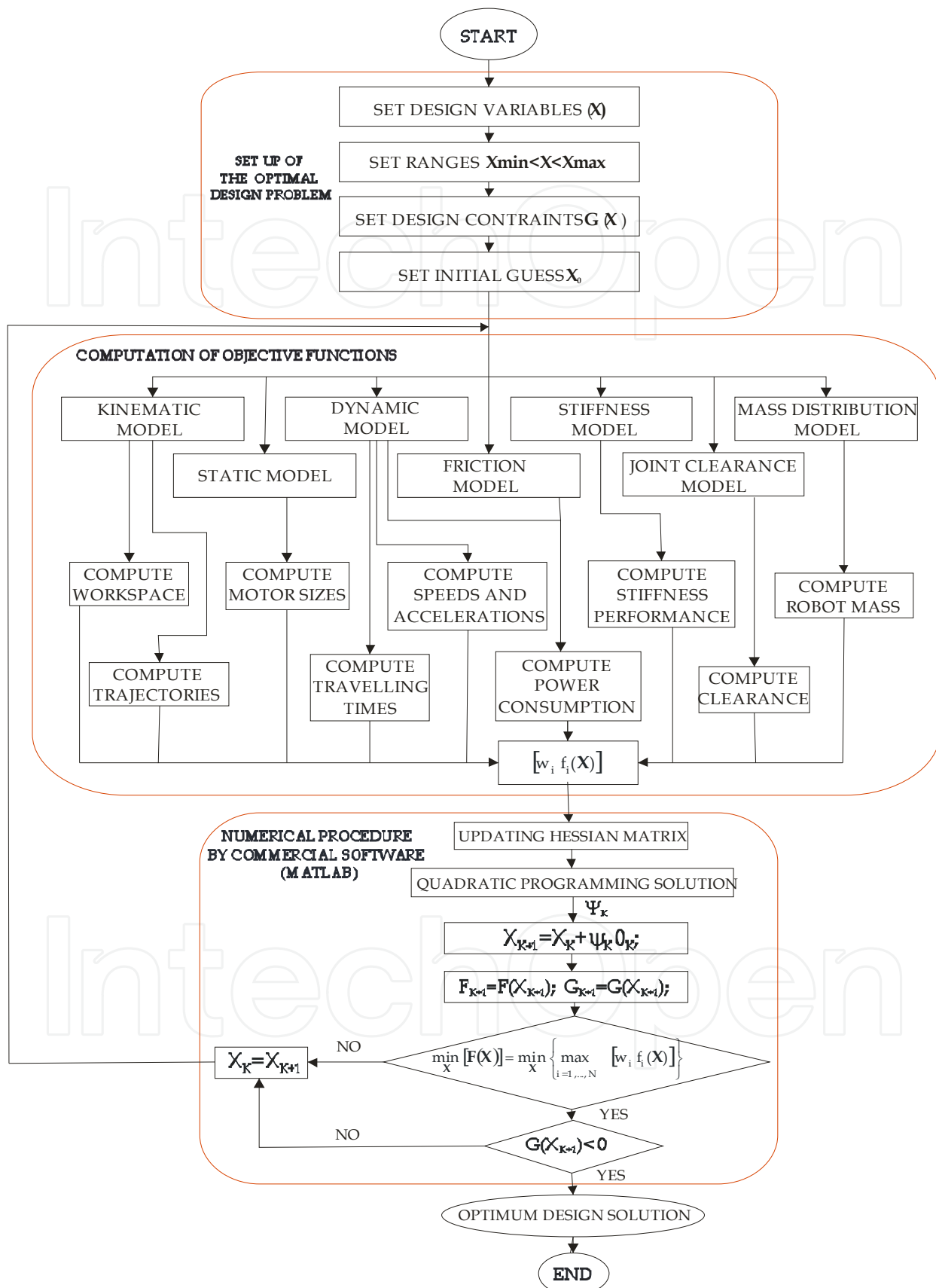

Fig. 2. A flow-chart for the proposed optimal design procedure by using MATLAB.

The analysis of manipulator performance should be aimed to computational algorithms that can be efficiently linked to the solving technique of highly non-linear optimal design of manipulators. Among the design criteria special attention should be addressed to stiffness, since it can directly affect the successful and efficient use of any robotic system for a given task as mentioned, for example, in (ANSI, 1990), (UNI, 1995), (Duffy, 1996), (Rivin, 1999).

3. Stiffness analysis for multibody robotic systems

A load applied on a body produces changes in the geometry of a body that are known as deformations or compliant displacements. Stiffness can be defined as the capacity of a mechanical system to sustain loads without excessive changes of its geometry (Rivin, 1999). Moreover, the stiffness of a body can be defined as the amount of force that can be applied per unit of compliant displacement of the body (Nof, 1985), or the ratio of a steady force acting on a deformable elastic medium to the resulting displacement. Compliant displacements in a multibody robotic system allow for mechanical float of the end-effector relative to the fixed base. This produces negative effects on static and fatigue strength, efficiency (friction losses), accuracy, and dynamic stability (vibrations) (Rivin, 1999). However, in some limited cases, compliant displacements can have even a positive effect if they are properly controlled. In fact, they can enable the correction of misalignment errors encountered for example when parts are mated during assembly operations (Nof, 1985), or in peg into hole tasks, (Tsumugiwa et al., 2002), or in deburring tasks (Schimmels, 2001), or in the operation of prosthetic limbs (English and Russell, 1999).

The analysis and evaluation of stiffness performances can be achieved by using finite element methods or lumped parameter models. The finite elements methods can provide accurate results but they require the simulation of a different model for each configuration assumed by a multibody robotic system. Therefore, models with lumped parameters are usually preferred in the literature since only one model is needed and since they require less computational efforts with respect to finite elements methods (Carbone, 2006).

The compliance of each component of a multibody robotic system can be modelled with lumped parameters by using linear and torsion springs as proposed for example in (Gosselin, 1990), (Duffy, 1996), (Tsai, 1999), (Ceccarelli, 2004). These lumped parameters are used for taking into account both stiffness properties of actuators and flexibility of links. Figures 3a) and b) show two models with lumped parameters for multibody robotic systems. In particular, Fig3a) shows a model of a 2R serial manipulator. Its links are elastically compliant and have been modelled as springs. Figure 3b) illustrates a planar parallel manipulator having three RPR legs connecting the movable plate to the fixed plate. Even in this scheme springs have been used to model the elastic compliance of the links. Schemes similar to Fig.3 can be defined for any multibody robotic system.

One can consider a compliant multibody robotic system in equilibrium with an externally applied wrench \mathbf{W} that acts upon it in a point A. This point can be located on the robot end-effector and a reference frame $X_A Y_A Z_A$ can be attached to point A as shown in Figs.3a) and b). In this condition, a change in the applied wrench \mathbf{W} will cause a compliant displacement of the multibody robotic system. In particular, the reference frame attached to point A will change in $X'_A Y'_A Z'_A$. In the most general case, a translation and rotation of the reference frame occurs.

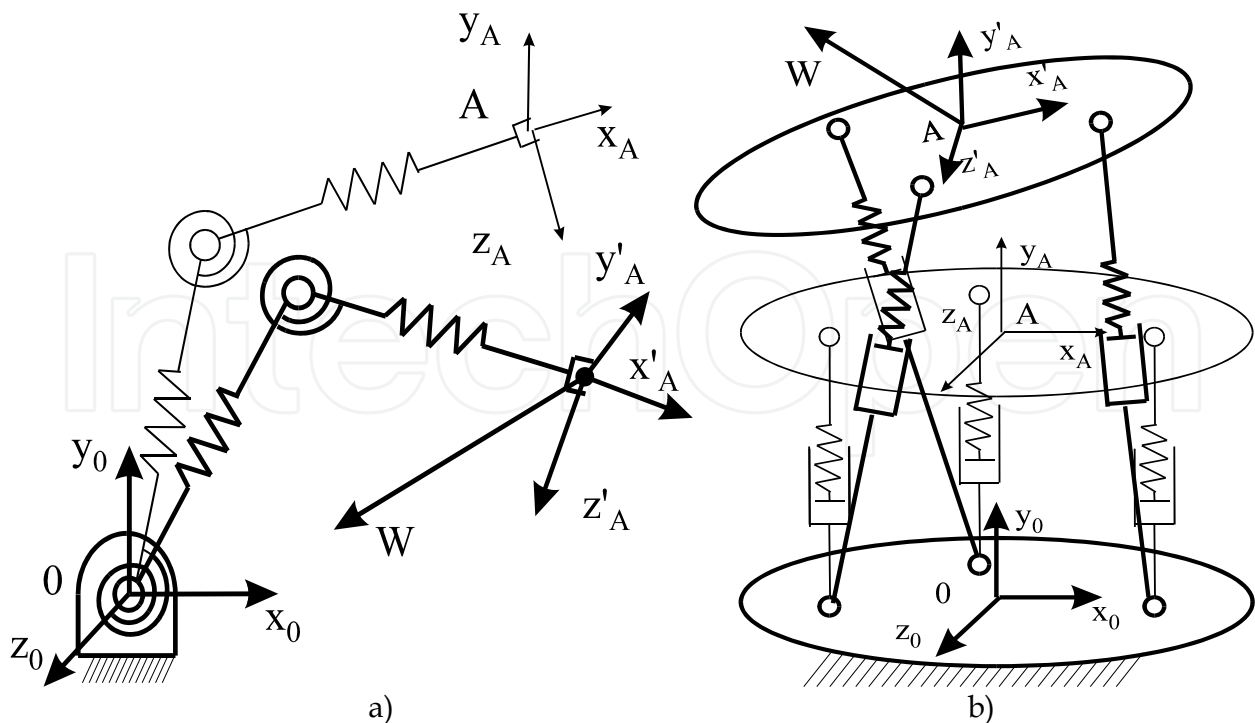

Fig. 3. Schemes of elastically compliant multibody robotic systems: a) a 2R serial manipulator; b) a planar parallel manipulator with three RPR legs.

Usually the purpose of the stiffness analysis is the definition of the stiffness of the overall system through the derivation of a Cartesian stiffness matrix \mathbf{K} . This stiffness matrix \mathbf{K} express the relationship between the compliant displacements $\Delta\mathbf{S}$ occurring to a frame fixed at the end of the kinematic chain when a static wrench \mathbf{W} acts upon it and \mathbf{W} itself. Considering Cartesian reference frames, 6×1 vectors can be defined for compliant displacements $\Delta\mathbf{S}$ and external wrench \mathbf{W} as

$$\begin{aligned} \Delta\mathbf{S} &= (U_x, U_y, U_z, U_\alpha, U_\gamma, U_\delta)^t \\ \mathbf{W} &= (F_{X'}, F_{Y'}, F_{Z'}, T_{X'}, T_{Y'}, T_{Z'})^t \end{aligned} \quad (8)$$

where $U_x, U_y,$ and U_z are the differences between the coordinates and U_α, U_γ and U_δ are the differences between the Euler angles of the reference frames $X'_A Y'_A Z'_A$ and $X_A Y_A Z_A$ that are expressed with respect to the fixed reference frame $X_0 Y_0 Z_0$; F_X, F_Y and F_Z are the force components acting upon point A in X, Y and Z directions, respectively; T_X, T_Y and T_Z are the torque components acting upon point A along X, Y and Z directions, respectively.

The relationship between the vector $\Delta\mathbf{S}$ and \mathbf{W} can be written in the form

$$\mathbf{K}(\mathbf{q}) : \mathfrak{R}^6 \rightarrow \mathfrak{R}^6, \quad \mathbf{W} = \mathbf{K} \Delta\mathbf{S} \quad (9)$$

where \mathbf{K} is the so-called 6×6 Cartesian stiffness matrix or spatial stiffness matrix.

Therefore, Eq.(9) defines \mathbf{K} as a 6×6 matrix whose components are the amount of forces or torques that can be applied per unit of compliant displacements of the end-effector for the multibody robotic system. However, the linear expression in Eq.(9) is valid only for small

magnitude of the compliant displacements $\Delta \mathbf{S}$. Moreover, Eq.(9) is valid only in static conditions.

The entries in the 6x6 Cartesian stiffness matrix \mathbf{K} depends on the configuration assumed by the robotic system, on the reference frame in which it is computed, and on the stiffness properties of each components of the multibody robotic system. A 6x6 stiffness matrix can be derived through the composition of suitable matrices.

A first matrix \mathbf{C}_F gives all the wrenches \mathbf{W}_L , acting on manipulator links when a wrench \mathbf{W} acts on the manipulator extremity according to the expression

$$\mathbf{W} = \mathbf{C}_F \mathbf{W}_L \quad (10)$$

with the matrix \mathbf{C}_F representing the force transmission capability of the manipulator mechanism.

A second matrix \mathbf{K}_p gives the possibility to compute the vector $\Delta \mathbf{v}$ of all the deformations of the links when each wrench \mathbf{W}_{Li} on a i -th link given by \mathbf{W}_L , acts on the legs according to

$$\mathbf{W}_L = \mathbf{K}_p \Delta \mathbf{v} \quad (11)$$

with the matrix \mathbf{K}_p grouping the spring coefficients of the deformable components of a manipulator structure.

A third matrix \mathbf{C}_K gives the vector $\Delta \mathbf{S}$ of compliant displacements of the manipulator extremity due to the displacements of the manipulator links, as expressed as

$$\Delta \mathbf{v} = \mathbf{C}_K \Delta \mathbf{S} \quad (12)$$

Therefore, the stiffness matrix \mathbf{K} can be computed as

$$\mathbf{K} = \mathbf{C}_F \mathbf{K}_p \mathbf{C}_K \quad (13)$$

with matrix \mathbf{C}_F giving the force transmission capability of the mechanism; \mathbf{K}_p grouping the spring coefficients of the deformable components; \mathbf{C}_K considering the variations of kinematic variables due to the deformations and compliant displacements of each compliant component.

Matrices \mathbf{C}_K and \mathbf{C}_F can be computed, for example, as a Jacobian matrix and its transpose, respectively, as proposed in (Tsai, 1999), (Tahmasebi, & Tsai, 1992), (Carbone et al., 2003). Nevertheless, this is only an approximate approach as pointed out, for example, in (Alici & Shirinzadeh, 2003). A more accurate computation of matrices \mathbf{C}_K and \mathbf{C}_F can be obtained as reported, for example in (Carbone, 2003). The \mathbf{K}_p matrix can be computed as a diagonal matrix whose components are the lumped stiffness parameters of links, joints and motors that compose a multibody robotic system. The lumped stiffness parameters can be estimated by means of analytical and empirical expressions or by means of experimental tests. For example, the stiffness matrix of a generic beam element can be written as reported for example in (Kardestuncer, 1974),

$$K = \begin{bmatrix} \frac{EA}{L} & 0 & 0 & 0 & 0 & 0 \\ 0 & \frac{12EI_Z}{L^3} & 0 & 0 & 0 & -\frac{6EI_Z}{L^2} \\ 0 & 0 & \frac{12EI_Y}{L^3} & 0 & \frac{6EI_Y}{L^2} & 0 \\ 0 & 0 & 0 & \frac{GJ}{L} & 0 & 0 \\ 0 & 0 & \frac{6EI_Y}{L^2} & 0 & \frac{4EI_Y}{L} & 0 \\ 0 & -\frac{6EI_Z}{L^2} & 0 & 0 & 0 & \frac{4EI_Y}{L} \end{bmatrix} \quad (14)$$

where E is the Young modulus; A is the cross section area; L is the link length; I_Y and I_Z are the two principal moment of inertia of the cross sections; G is the shear modulus; J is the equivalent torsional moment of inertia. The stiffness of direct drive actuators can be computed by using an empirical expression as proposed in (Rivin, 1999) in the form

$$(k_m)^{-1} = \omega_0 v \tau_e \quad (15)$$

with

$$\begin{aligned} \tau_e &= L_r / R_r \\ v &= (((e/\Omega) - I_0) K_M) / \omega_0 \end{aligned} \quad (16)$$

where ω_0 is the no load angular velocity, R_r , L_r , e , Ω and K_M are the terminal resistance, inductance, voltage, resistance and torque constant of the motors, respectively. In presence of mechanical transmissions the values obtained by Eqs.(15) and (16) should be corrected by considering the transmission ratio and the stiffness properties of the transmission itself.

4. Stiffness as optimal design criterion

The stiffness matrix K can be computed numerically according with the flow chart that is proposed in Fig.4. A numerical algorithm can be composed of a first part in which the numerical values for the geometrical dimensions, masses and lumped stiffness parameters are defined. A second part defines the kinematic model, the force transmission model and the lumped parameter model through the matrices C_F , K_p , and C_K , respectively. Then, a third part can compute a close-form expression of the stiffness matrix K by means of Eq.(13). It is worth noting that the matrices C_F , and C_K are configuration dependant. Therefore, also the stiffness matrix K is configuration dependent. Thus, one should define configuration(s) of a multibody robotic system where the stiffness matrix will be computed. The configuration(s) should be carefully chosen in order to have significant information on the stiffness performance of the system in its whole workspace.

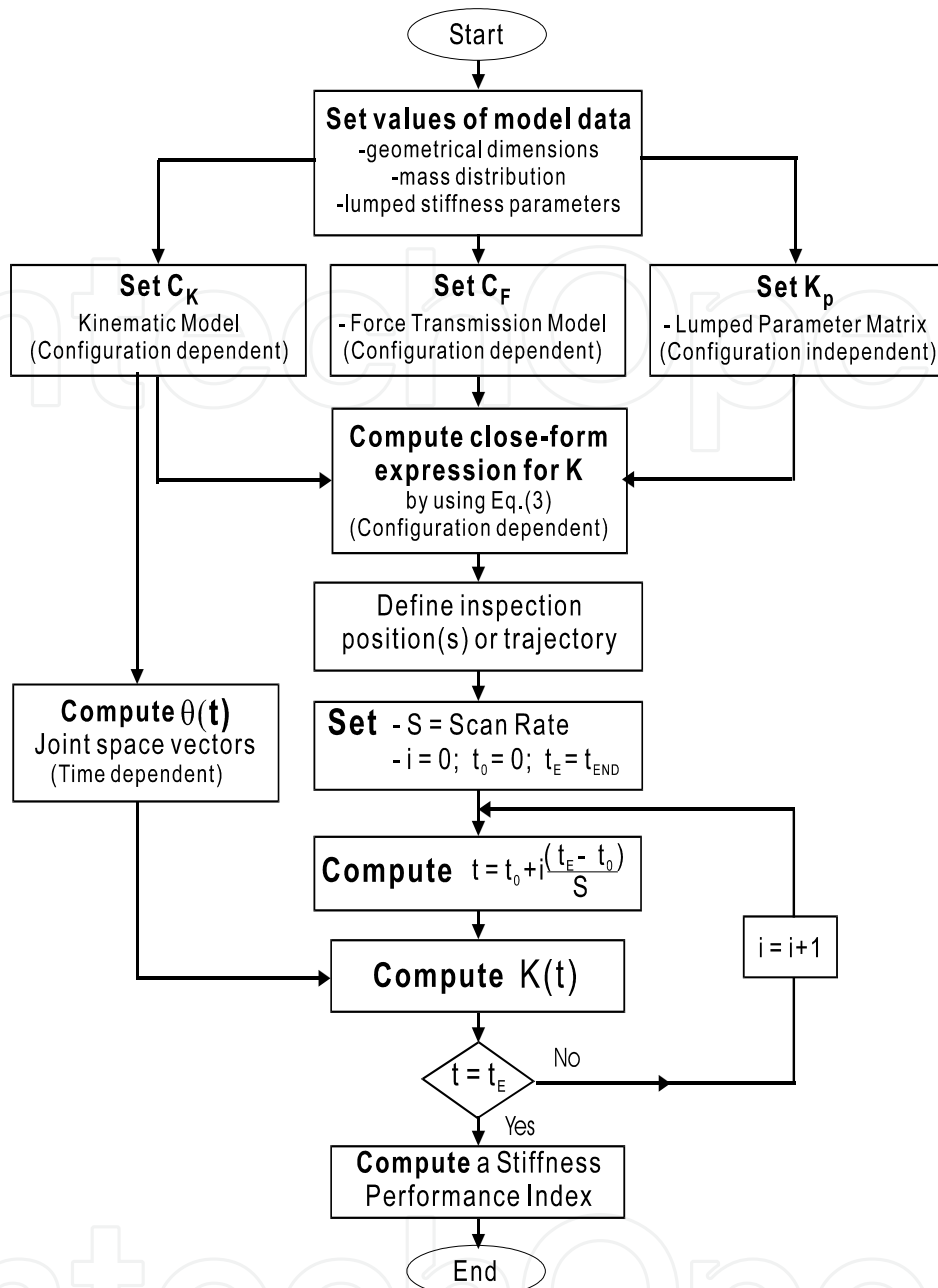

Fig. 4. A flow-chart for the proposed numerical computation of stiffness performance.

Then, the kinematic model can be used for computing the vector θ that express input angles and strokes in the joint space for any pose assumed by a multibody robotic system.

In some cases, a multibody robotic system can have few trajectories that are mostly used during its operation. In these cases, a kinematic model can be used together with a proper path planning strategy for computing a vector $\theta(t)$ that express input angles and strokes in the joint space as function of time for a given trajectory. Thus, the vector $\theta(t)$ can be used for computing the stiffness matrix as function of time for a given end-effector trajectory. However, it is necessary to define a scan rate S , and the time t_{END} in which the motion of the robotic system will be completed. Of course, the higher is the scan rate the higher is the number of configurations in which stiffness matrix K is computed. It is worth noting that the

accuracy in the estimation of model data such as geometrical dimensions, and values of lumped stiffness parameters can significantly affect the accuracy of the stiffness matrix that is computed through Eq.(13). Thus, experimental tests should be carried out in order to validate stiffness model and model data.

Once the stiffness matrix has been derived, it is necessary to be able to compare different stiffness matrices (for comparing local stiffness properties) and estimate the stiffness performance of the overall system (for comparing global stiffness properties). A local stiffness index can be directly related with the Cartesian stiffness matrix by means of different mathematical operators that can be applied to a matrix. Feasible choices can be the determinant, trace, norm, eigenvalues and eigenvectors at a given posture. In particular, the determinant of a stiffness matrix K is invariant in similarity transformations. Thus, it does not rely on the choice of reference frame. Moreover, it can be computed as

$$\det(K) = (-1)^6 + P_1(-1)^5 + P_2(-1)^4 + P_3(-1)^3 + P_4(-1)^2 + P_5(-1) + P_6 \quad (17)$$

where P_i (with $i=1,2,\dots,6$) is the sum of the principal minors of order i of the matrix K .

But the determinant can be expressed also as the product of matrix eigenvalues as given in Matrix Algebra. Each entry K_{ij}^{-1} of the inverse matrix of K can be computed as

$$K_{ij}^{-1} = \frac{(K)_{ji}}{\det(K)} \quad (18)$$

where $(K)_{ji}$ is the algebraic complement of the entry K_{ij} of the matrix K with $i, j=1,2,\dots,6$. Thus, if the determinant $\det(K)$ is zero, the Eq.(13) gives singular values and Eq.(12) cannot be computed. Therefore, the determinant of K can be used as a performance index to investigate synthetically the effect of the design parameters on the stiffness behaviour, since it is easy to compute and it is particularly significant for determining stiffness singularity properties. Merits and drawbacks of other local indices are summarized in (Carbone & Ceccarelli, 2007).

A local index of stiffness performance is neither suitable for an accurate design analysis nor useful for a comparison of different designs. In fact, even if a multibody robotic system has suitable stiffness for a given system posture it can have inadequate stiffness at other postures. Therefore, one should look at stiffness performance at all points of workspace or define a single global stiffness index over the whole workspace yet.

A global index of stiffness performance for a multibody robotic system can be defined by means of graphical methods that are based on plotting curves connecting postures having the same value of the local stiffness index (iso-stiffness curves or surfaces), as proposed for example in (Merlet, 2006). Nevertheless, the number of iso-stiffness curves or surfaces that one can plot is graphically limited. Moreover, few curves or surfaces usually do not provide sufficient insight of the overall stiffness behaviour of a multibody robotic system. These aspects significantly reduce the effectiveness of iso-stiffness curves or surfaces.

Global stiffness indices can be defined also in a mathematical form by using minimum, maximum, average or statistic evaluations of a local stiffness index. For example, one can compute a global index in the form

$$GI_d = \min |\det(K)| \quad (19)$$

It is worth noting that a GI_d index equal to zero means that at least one singular configuration is within the workspace of a multibody robotic system. This is a critical situation that should be avoided at the design stage.

Among the possible method the determinant of K and maximum values of compliant displacements can be most easily related with a physical meaning. However, one should note that the choice of a comparison method is strongly related with the application field. For example, eigenvalues and eigenvectors and the identification of a center of compliance are widely used for machine tools and grasping systems, respectively, as reported for example in (Gosselin & Angeles, 1991).

5. Other optimal design criteria

Alternatives in formulating and choosing optimality criteria are always possible depending on the designer experience, design goals, and manipulator applications. Many different indices and/or their computations have been proposed in a rich literature on manipulators in order to provide a numerical value of the performance of a manipulator. Those indices can be used and they have been used with proper formulation as optimality criteria in specific algorithms for optimal design of specific manipulators. Of course, any optimality criterion as well as its formulation can suffer drawbacks in terms of conceptual aim and numerical efficiency. Considering the above-mentioned aspects one can propose optimality criteria for taking into account, just to cite few examples, well known design aspects such as

- workspace,
- dynamic performance,
- lightweight design.

One can even define optimality criteria for other specific design aspects such as safety in robots for service tasks as proposed, for example, in (Castejón et al., 2007).

5.1 Workspace

The workspace is one of the most important kinematic properties of manipulators, because of its impact on manipulator design and its location in a work cell. A manipulator workspace can be identified as a set of reachable positions by a reference point at the manipulator's extremity. This is referred as position workspace. Similarly, orientation workspace can be identified as a set of reachable orientations by a reference point at the manipulator's extremity. Interpreting the orientation angles as workspace coordinates permits to treat the determination of the orientation workspace likewise the determination of the position workspace when a Cartesian space is considered in the computations. A general numerical evaluation of the workspace can be deduced by formulating a suitable binary representation of a cross-section in the task-space, as described, for example, in (Ottaviano & Ceccarelli, 2002).

The workspace volume V can be computed considering the cross-sections areas A_z and the number of slices n_z that have been considered for the workspace volume evaluation, according to scheme of Fig. 5, as

$$V = \sum_{z=1}^{n_z} \left(\sum_{i=1}^{i_{\max}} \sum_{j=1}^{j_{\max}} (P_{ij} \Delta x \Delta y) \right) \Delta z \quad (20)$$

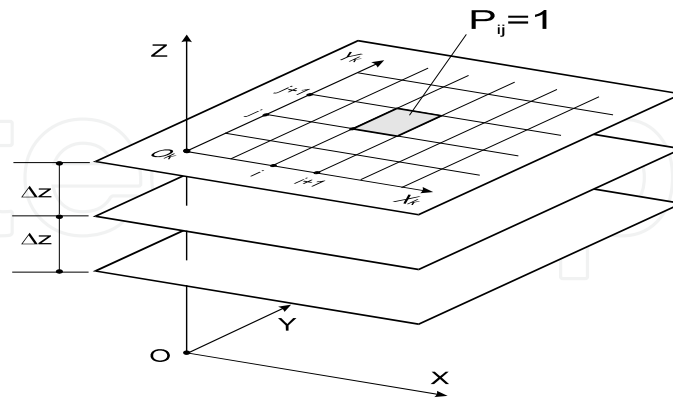

Fig. 5. A binary representation of manipulator workspace (Ottaviano & Ceccarelli, 2002).

Similarly, the orientation workspace can be analyzed by using a suitable binary representation with another binary matrix for a workspace region that can be described in term of orientation angles. Therefore, an optimum design problem with objective functions regarding workspace characteristics can be formulated as finding the optimal design parameters values to obtain the position and orientation workspace volumes that are as close as possible to prescribed ones in the form

$$f_{PW}(\mathbf{X}) = \left| 1 - \frac{V_{pos}}{V'_{pos}} \right| \quad (21)$$

$$f_{OW}(\mathbf{X}) = \left| 1 - \frac{V_{or}}{V'_{or}} \right|$$

where $|\cdot|$ is the absolute value; the subscripts pos and or indicate position and orientation, respectively; and prime refers to prescribed values.

An optimality criterion for addressing workspace performance could be defined also by taking into account several other aspects such as the shape of the workspace, the absence of singularities or voids within the desired workspace, isotropy of the workspace, manipulability index for specific manipulative tasks.

5.2 Dynamic performance

An optimality criterion concerning with dynamic performance, power consumption and energy aspects of the path motion can be conveniently expressed in terms of the work that is needed by the actuators. In particular, the work by the actuators is needed for increasing the kinetic energy of the system in a first phase from a rest condition to actuators states at which each actuator is running at maximum velocity. In a second phase bringing the system back to a rest condition, the kinetic energy will be decreased to zero through the actions of

actuators and brakes. Thus, one can write the work W_{act} done by the actuators in the first phase of the path motion as an optimality criterion for optimal path generation as given by the expression

$$W_{act} = \sum_{k=1}^3 \left[\int_0^{t_k} \tau_k \dot{\alpha}_k dt \right] \quad (22)$$

in which τ_k is the k-th actuator torque; $\dot{\alpha}_k$ is the k-th shaft angular velocity of the actuator; and t_k is the time coordinate value delimiting the first phase of path motion with increasing speed of the k-th actuator. Therefore, trying to minimize the ratio W_{act} / W_{act0} with W_{act0} as a prescribed value, has the aim to size at the minimum level the design dimensions and operation actions of the actuators in generating a path between two given extreme positions. The prescribed value W_{act0} has to be chosen as referring to the power of a commercial actuator.

5.3 Lightweight design

Lightweight design is desirable in order to have a light mechanical structure for safety reasons and at the most for a general suitable maneuverability, installation, and location of the robot. A reasonable and computationally efficient expression of the lightweight design criterion can be given by

$$f_L(X) = \left| 1 - \frac{M_T}{M_d} \right| \quad (23)$$

as referred to M_T which is the overall mass of a robot and to M_d which is the desired overall mass of the same robot. The robot mass, M_T can be computed as the sum of the mass of links and joints M_i , the mass of actuators M_j , and the mass of cables and sensors M_k , in the form

$$M_T = \sum_{i=1}^{n_{link}} M_i + \sum_{j=1}^{m_{actuator}} M_j + \sum_{k=1}^{l_{component}} M_k \quad (24)$$

It is worth noting that the most critical aspect for obtaining a lightweight mechanical design is to reduce the weight of links and joints. In fact, cables and sensors are usually market components with given size and mass. Although actuators are usually market components their size and mass is mainly selected according to the desired output power and dynamics.

6. Cases of study

6.1 A Parallel Manipulator

The CaPaMan (Cassino Parallel Manipulator) manipulator has been considered to test the engineering feasibility of the above-mentioned formulation for optimal design of manipulators as specifically applied to parallel architectures. CaPaMan architecture has

been conceived at LARM in Cassino since 1996, where a prototype has been built for experimental activity. Indeed, by using the existing prototype, simulations have been carried out also to validate the proposed optimum design by considering several guess solutions and imposing workspace and stiffness characteristics of the built prototype. According to those satisfactory results a numerical example has been proposed to obtain the same workspace characteristics but with enhanced stiffness and conditions for avoiding singularities. A schematic representation of the CaPaMan manipulator is shown in Fig.6a), and a photo of a prototype is shown in Fig.6b).

Position and orientation workspace volumes can be conveniently evaluated by using Eqs.(20-21) and the algebraic formulation for the Kinematics of CaPaMan manipulator that has been reported, for example, in (Ottaviano & Ceccarelli, 2002). Similarly, singularity analysis for CaPaMan manipulator has been reported in (Ottaviano & Ceccarelli, 2002).

Stiffness analysis of CaPaMan has been reported in (Ceccarelli & Carbone, 2002). By modeling each leg of CaPaMan as shown in Fig.7, the stiffness matrix of CaPaMan can be derived as defined in Eq.(13) with

$$C_F = M_{FN} ; \quad C_K = C_P^{-1} A_d^{-1} \quad (25)$$

where M_{FN} is a 6x6 transmission matrix for the static wrench applied on H and transmitted to points H_1 , H_2 and H_3 of each leg; K_p is a 6x6 matrix with the lumped stiffness parameters of the 3 legs; C_p is a 6x6 matrix giving the displacements of the links of each leg as a function of the displacements of points H_1 , H_2 and H_3 ; A_d is a 6x6 matrix that has been obtained by using the Direct Kinematics of the CaPaMan to give the position of point H on the movable plate as function of the position of points H_1 , H_2 and H_3 in the form

$$X_H = A_d v \quad (26)$$

with $v = [y_1, z_1, y_2, z_2, y_3, \Delta z_3]^T$ and $X_H = [x_H, y_H, z_H, \varphi, \theta, \psi]^T$. The derivation of matrices M_{FN} , K_p , A_d , and C_p for CaPaMan can be found in (Ceccarelli & Carbone, 2002).

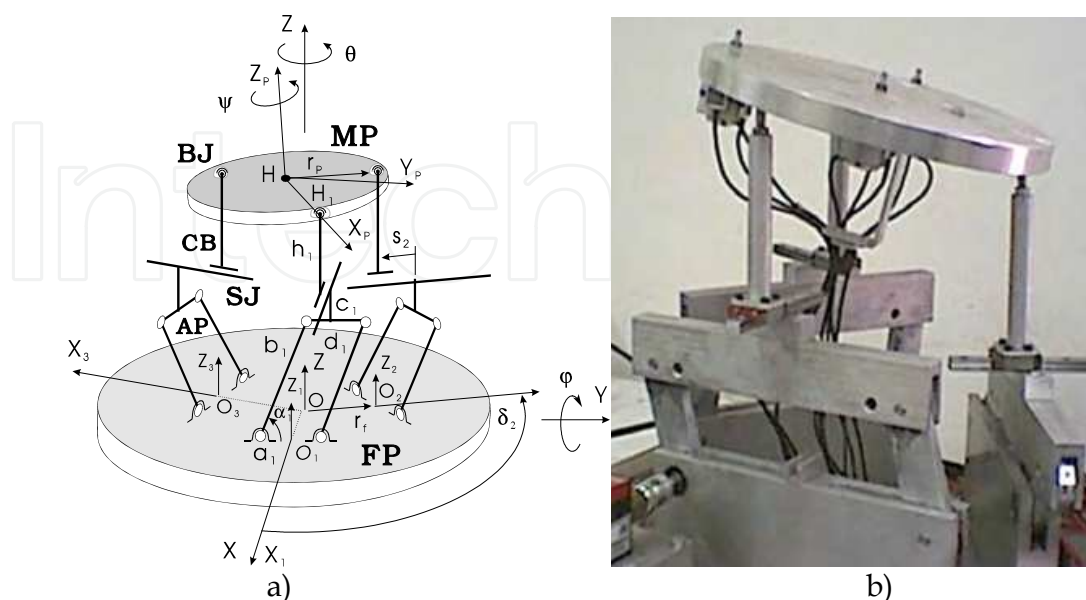

Fig. 6. CaPaMan (Cassino Parallel Manipulator) design: a) a kinematic diagram; b) a built prototype at LARM.

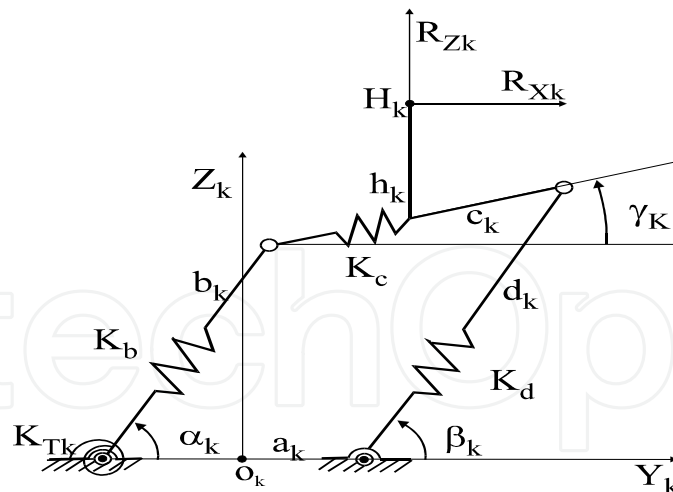

Fig. 7. A scheme for stiffness evaluation of a CaPaMan leg.

The lumped stiffness parameters has been assumed as $k_{bk}=k_{dk}=2.625 \times 10^6$ N/m and $k_{Tk}=58.4 \times 10^3$ Nm/rad; the couplers c_k have been assumed rigid bodies because of the massive design that has been imposed to have a fix position of the sliding joints. Further details on the derivation of the matrices in Eqs.(28) and (29) can be found in (Ceccarelli & Carbone, 2002). In the numerical example, for evaluation and design purposes we have assumed $r_p = r_f$, $a_k = c_k$, $b_k = d_k$.

Results of the proposed design procedure as applied to the CAPAMAN architecture are reported in Figs. 10, 11, and 12 and Table 1 and 2. In particular, the evolution of the objective functions is reported in Fig. 8, from which one can note that the numerical procedure takes 65 iterations to converge to the optimum values that are reported in Table 1. Evolution of design parameters and constraints are shown in Figs.9 and 10. Design characteristics for the optimum solution are reported in Table 2. For the proposed numerical example, the Inverse Kinematic singularities related to matrix A in Eq. (24) gives the condition that input crank angle α_i should be different from 90 deg, (for $i=1,2,3$). This condition and Direct Kinematic singularities have been taken into account in the numerical procedure through a constraint equation.

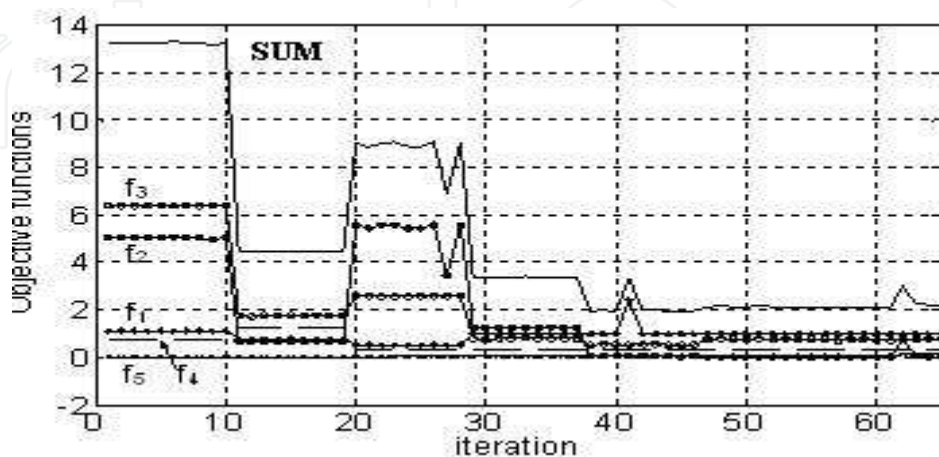

Fig. 8. Evolution of the objective functions versus number of iterations for the example of CaPaMan optimal design of Fig.6.

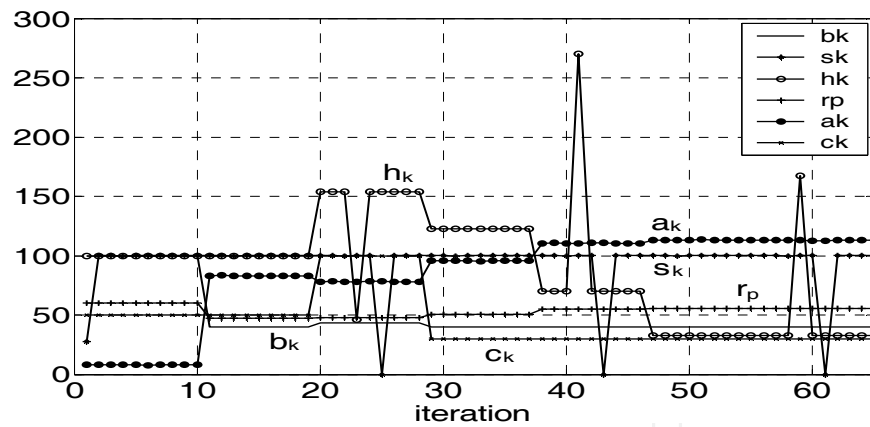

Fig. 9. Evolution of design parameters versus number of iterations for the example of CaPaMan optimal design of Fig.6.

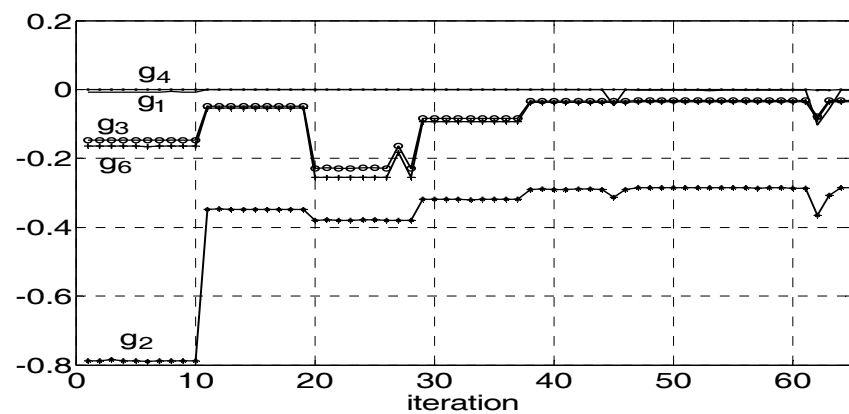

Fig. 10. Evolution of design constraint versus number of iterations for the example of CaPaMan optimal design of Fig.6 and Table 1.

Values	a_k (mm)	b_k (mm)	h_k (mm)	r_p (mm)	α_k (deg)	s_k (mm)
Initial Guess	27.85	100.0	100.0	60.0	45;135	50.0
Optimal	113.1	40.0	32.9	55.8	45;112	30.0

Table 1. Design parameters for optimal CaPaMan design of Figs.8 to 10.

Values of workspace ranges	Δx (mm)	Δy (mm)	Δz (mm)	$\Delta \varphi$ (deg)	$\Delta \psi$ (deg)	$\Delta \theta$ (deg)
Initial Guess	105.8	112.4	29.3	38.0	179.9	321.8
Optimal	48.6	55.9	11.7	16.1	179.9	212.4
Values of compliant displacements	U_x (mm)	U_y (mm)	U_z (mm)	U_α (deg)	U_γ (deg)	U_δ (deg)
Initial Guess	$5.5 \cdot 10^{-4}$	$6.7 \cdot 10^{-6}$	$3.2 \cdot 10^{-4}$	$2.4 \cdot 10^{-5}$	$2.4 \cdot 10^{-5}$	$2.3 \cdot 10^{-9}$
Optimal	0.002	$1.6 \cdot 10^{-6}$	0.001	$6.0 \cdot 10^{-4}$	$6.5 \cdot 10^{-4}$	$2.3 \cdot 10^{-8}$

Table 2. Design characteristics of optimum solution for optimal CaPaMan design of Figs.8 to 10 and Table 1.

The numerical example for the CaPaMan manipulator has been elaborated in an Intel

Pentium M 2.00 GHz. The algorithm takes 65 iterations to converge to an optimal solution with a computation time of 4 min and 8 sec. The accuracy for the objective function evaluations has been set equal to $1e-5$ and the accuracy for the design parameters has been set equal to $1e-3$. Numerical examples show satisfactory results with a quite rapid convergence to a feasible optimal solution. The robustness of the design algorithm is proved in some extent even by relatively large distance of the computed optimal design solutions from the guess values.

6.2 A robotic hand

LARM Hand as been considered to test the engineering feasibility of the above-mentioned formulation for optimal design of robotic hands. LARM Hand architecture has been conceived at LARM in Cassino in the second half of 90's. Four different design solutions have been developed and built at LARM as shown in Fig.11. Recently, special care has been addressed in designing a novel underactuated linkage mechanism with passive elements that can adjust the position of links and envelope object with only one motor as input actuator. A feasible design schemes has been defined as shown in Fig. 12.

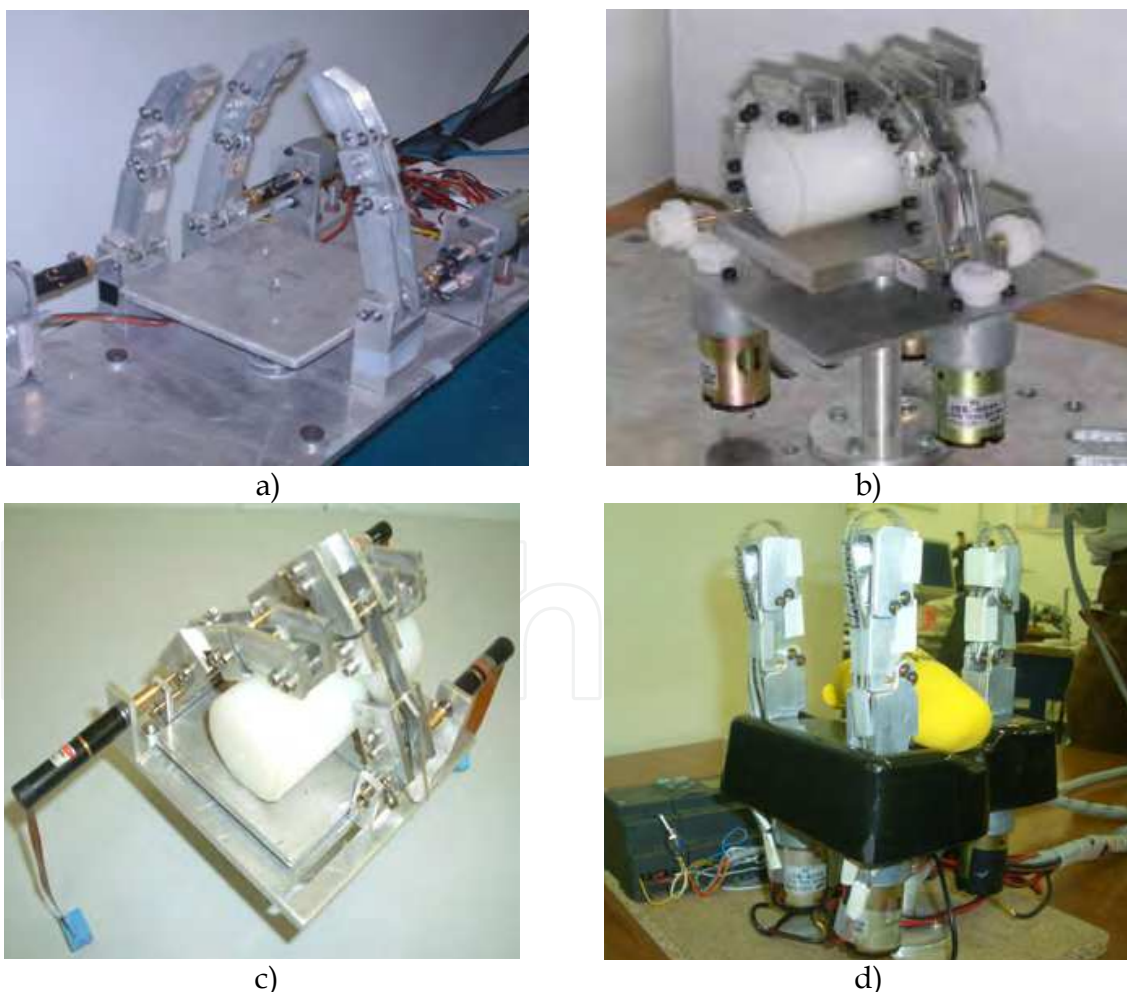

Fig. 11. LARM Hand prototypes in Cassino: a) version I; b) version II; c) version III; d) version IV.

Link sizes of a first solution for the proposed finger mechanism are listed in Table 3 by referring to previous LARM Hand prototypes.

Initial values for coefficients of the springs have been determined as $k_1 = k_2 = 7.7 \times 10^{-2}$ Nm/rad. Referring to Fig.12 the design parameters can be considered as angles of the links, and the coefficients of the springs, namely L_i , α_i , δ_i , θ_i , for $i=1,2,\dots,9$; θ_{s1} , s_2 , k_1 , k_2 , c_1 , c_2 . A design for an anthropomorphic finger must fulfil basic features such as human-like contact forces, actuation efficiency, grasping capability, underactuated design, compact size, transmission efficiency.

The multi-objective design optimization problem has been solved by using a numerical procedure through Matlab Optimization Toolbox. For the numerical example the data have been given as reported in Table 3. The sizes and forces needed for the grasping have been defined by referring to experimental tests on a cylindrical object with a diameter 60 mm as reported in (Yao et al., 2009). Two main objective functions F1 and F2 have been defined. F1 combines together the optimal criteria for compact size, underactuated design, and stiffness performance. F2 combines together human-like contact forces, actuation efficiency, grasping capability, and transmission efficiency, (Yao et al., 2009).

Optimal solution is obtained after 81 iterations for F1 and 363 iterations for F2, with total 168 seconds of CPU computation with standard PC Genuine Intel(T2050). The accuracy for the objective function evaluations has been set equal to $1e-5$ and the accuracy for the design parameters has been set equal to $1e-3$. Results of optimal program are shown in Figs. 13 and 14 and numerical values are listed in the tables 4, and 5. The actuator torque f_2 is obtained as about 0.15 Nm. This is due to an optimization of driving transmission efficiency and reduction of coefficients for springs and dampers. Additionally, it has been checked that the transmission angles are obtained in a reasonable range while the final grasping configuration occurs.

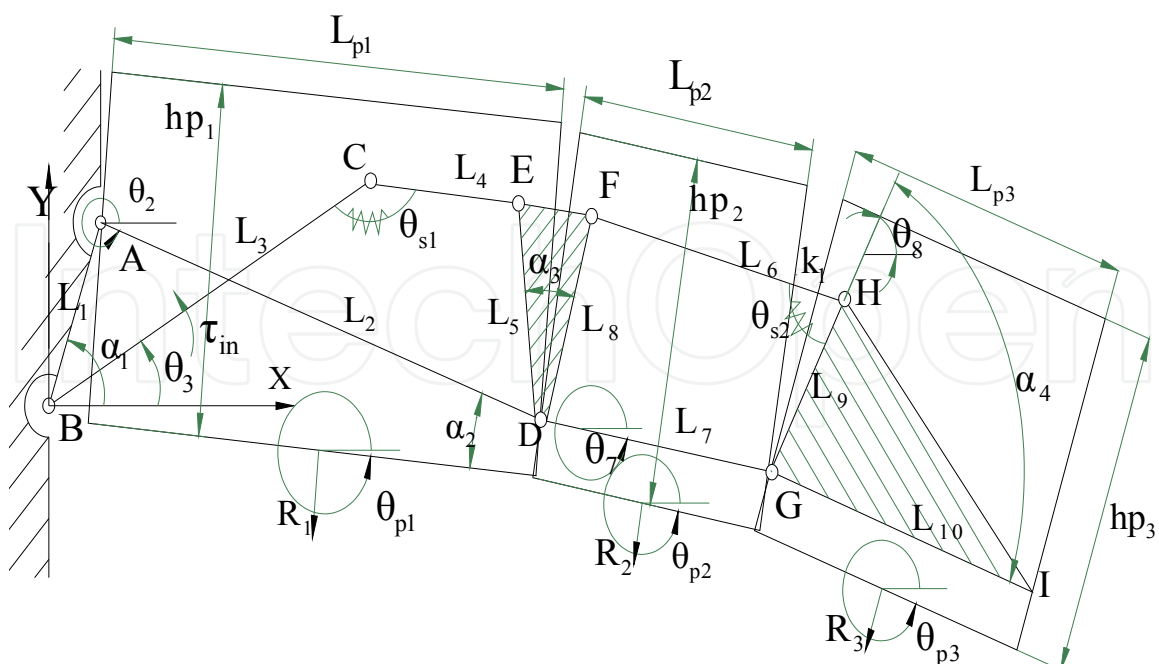

Fig. 12 The design parameters and phalanx bodies for a novel underactuated driving mechanism for LARM Hand.

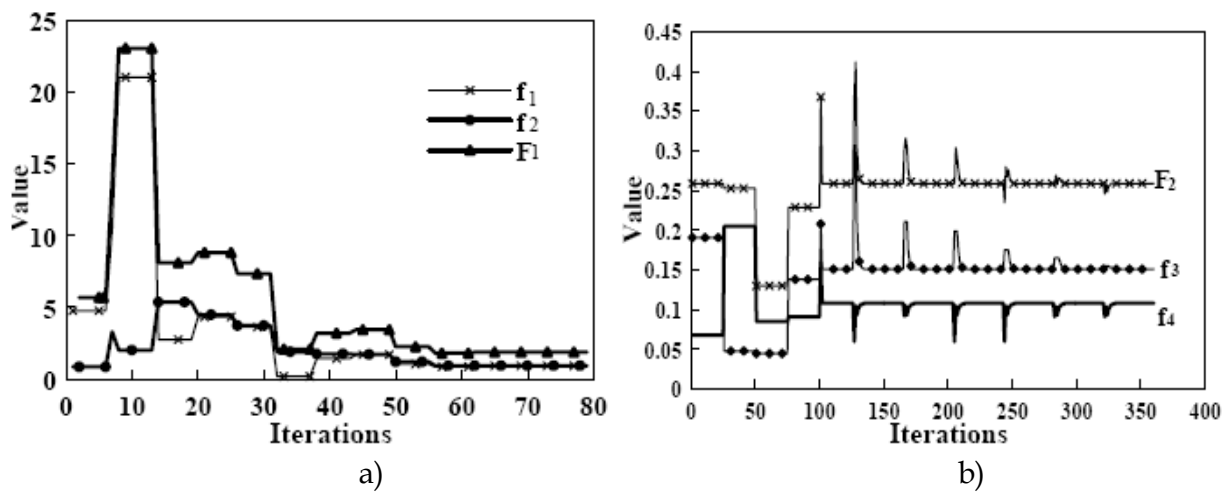

Fig. 13. Evolution of the objective functions: a) evolution of the objective functions within F1; b) evolution of the objective functions within F2.

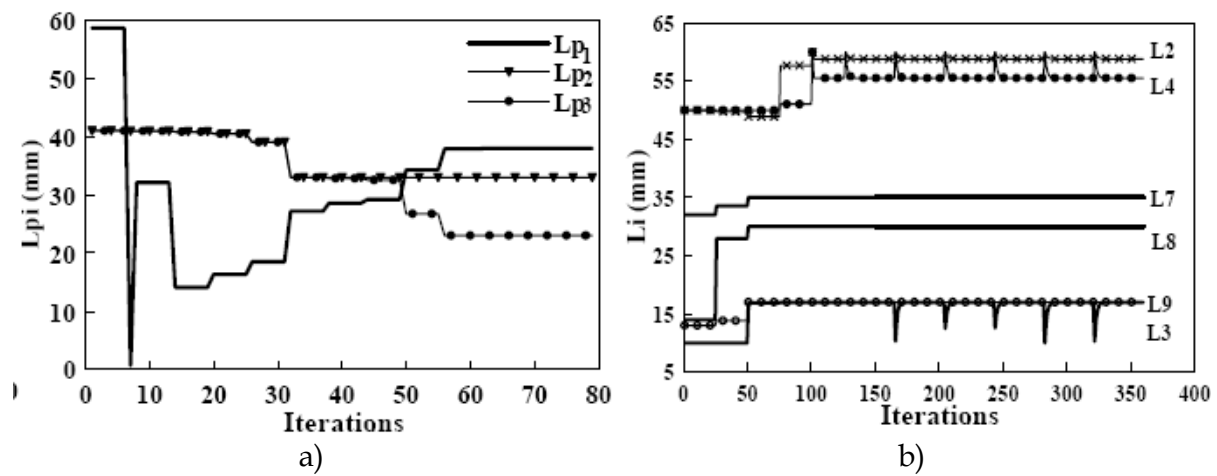

Fig. 14. Results of the optimal design procedure: a) evolution of phalanx sizes; b) evolution of design parameters.

i	1	2	3	4	5	6	7	8	9	10
L_i (mm)	11.2	66.5	12.0	51.4	17.8	37.1	33.1	14.3	13.0	4 1 . 0
L_{pi} (mm)	60.0	41.5	41.0	-	-	-	-	-	-	-
h_{pi} (mm)	20.0	20.0	20.0	-	-	-	-	-	-	-
α_i (deg)	64.4	22.7	23.1	123.1	-	-	-	-	-	-
θ_{pi0} (deg)	0.0	0.0	0.0	-	-	-	-	-	-	-

Table 3. Initial guess design parameters for the proposed driving mechanism in Fig. 12.

Parameters	$\lambda_{tr1}/\lambda_{tr2}/\lambda_{tr3}$ (deg)	$k_1/k_2(10^{-2})$ Nm/rad)	c_1/c_2 (Nms/deg)	h_{pi}/D (mm)	E_{spring}/τ_{in} (N/m)
Guess solution	140/153/85	0.210/0.008	0.25/0.25	20.0/89.8	0.19/0.07
Optimal solution	97/113/79	0.150/0.011	0.05/0.05	20.0/113.2	0.15/0.10

Table 4. Design parameters before and after optimality.

i	1	2	3	4	5	6	7	8	9	10
L_i (mm)	7.8	61.1	16.2	54.4	16.8.	33.7	35.0	30.0	17.1	23.2
L_{pi} (mm)	37.9	33.1	23.2	-	-	-	-	-	-	-
α_i (deg)	78.7	62.8	25.5	76.4	-	-	-	-	-	-

Table 5. Structure parameters of the optimal results for the underactuated finger mechanism.

6.3 A humanoid leg

The leg module of the humanoid robot WABIAN R-IV has been considered to test the engineering feasibility of the proposed formulation for optimal design of humanoid legs. WABIAN R-IV has been conceived at Waseda University within the series of WABIAN humanoid robots that started to walk on 1972. A collaboration has been established with LARM since 2001 aiming to investigate kinematics, stiffness, and dynamics aspects both from theoretical and experimental point of view.

Figures 15a), b) and c) show the humanoid robot WABIAN R-IV and a detailed kinematic model for its leg module, respectively. It is worthy to note that in this model the Denavit-Hartenberg convention has been used in order to define position and orientation of the link coordinate frames $X_i Y_i Z_i$.

By considering the references frames of Fig.15c), the D-H link parameters for the kinematic chain of the leg can be computed as shown in Table 6. Then, the rotation matrices expressing the relation between the frames can be straightforward derived by using the D-H link parameters in in Table 6. Further details can be found in (Carbone et al. 2003).

A multi-objective optimization problem in the form of Eq.(23) can be defined also in order to find an optimum compromise between stiffness and lightweight design. It is worthy to note that the objective functions are affected by the choice of shape of links and material that is used. In this paper, hollow square sections are assumed, since they give high stiffness performances as pointed out in (Rivin, 1999). Moreover, it has been decided to use as material Extra Super Duralluminium having Young module $E=70$ GPa and specific weight $\rho=3000$ kg/m³ as based on previous experiences at Waseda University.

Figures 16 shows the plot of the objective functions versus the number of iterations for a successful application of the proposed optimum design procedure. Figure 17 shows the plots of the compliant displacements versus the number of iterations. Tables 7 shows the optimum set of design sizes and evolution of the objective function that have been obtained as result of the proposed formulation to give an optimal compromise between stiffness and lightweight design. The objective function has evolved from an initial value of 37.028 to a final value of 0.3597. The numerical example for the leg module of the humanoid robot WABIAN R-IV has been elaborated in an Intel Pentium M 2.00 GHz. The algorithm takes 2600 iterations to converge to an optimal solution with a computation time of about 30 min. The accuracy for the objective function evaluations has been set equal to $1e-5$ and the accuracy for the design parameters has been set equal to $1e-3$.

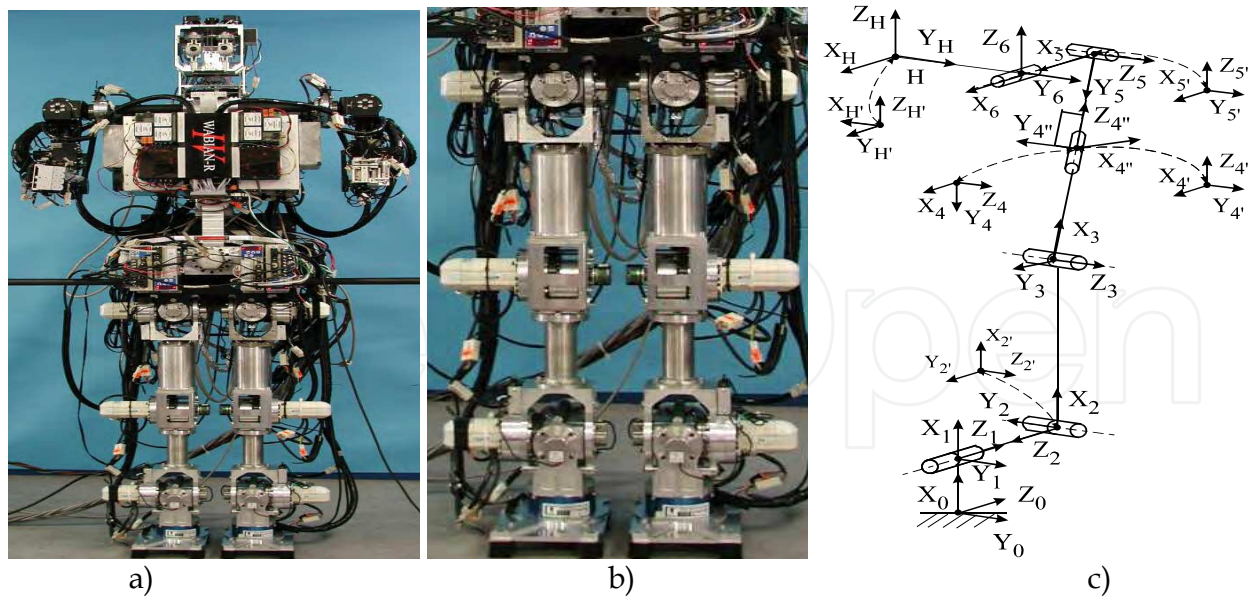

Fig. 15. WABIAN-RIV: a) a photo of the built prototype ; b) a zoom view of the leg module; c) a kinematic scheme for the leg module.

Link No.	D-H par.	$\alpha_{(i-1)}$ [deg]	$a_{(i-1)}$ [mm]	d_i [mm]	θ_i [deg]
1		0	$a_0=185$	0	θ_1
2		180	0	$-d_2=0$	0
2'		90	0	0	θ_2
3		0	$a_2=300$	0	θ_3
4		0	$a_3=223.5$	0	90
4'		90	0	0	0
4''		0	0	0	θ_4+180
5		90	0	$-d_5=130$	180
5'		90	0	0	θ_5
6		θ_6	$a_5=0$	0	0
H'		0	0	$d_6=0$	-90
H		0	0	0	90

Table 6. D-H parameters for the leg module of WABIAN-RIV in Fig.15.

Link N.	Length [m]		Cross-section Edge [m]	
	Initial	Final	Initial	Final
1	0.05	0.323	0.034	0.008
2	0.185	0.119	0.028	0.009
3	0.159	0.382	0.021	0.004
4	0.141	0.135	0.022	0.027
5	0.224	0.055	0.021	0.018
6	0.354	0.099	0.016	0.019

Table 7. Optimum set of design sizes.

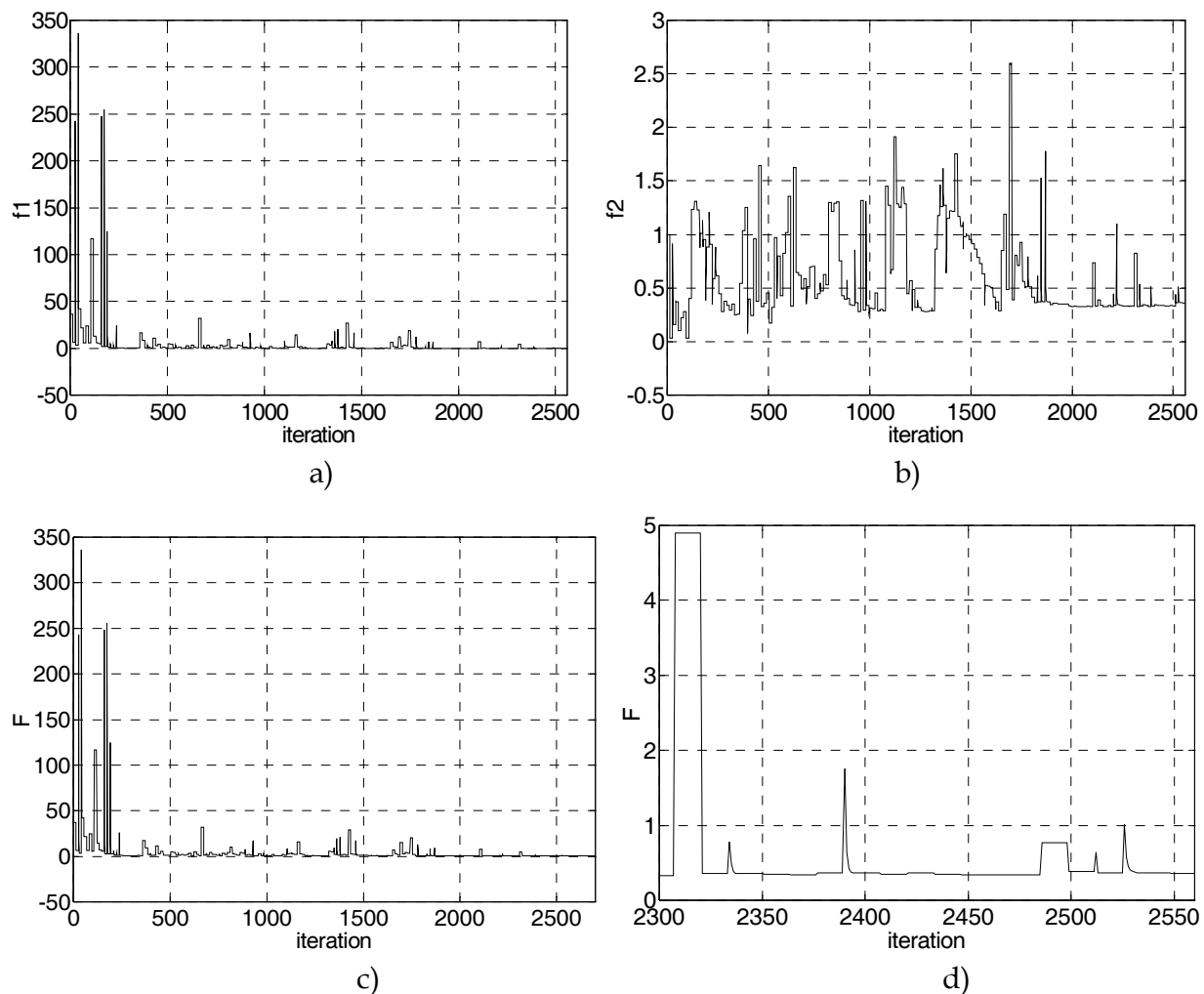

Fig. 16. Objective functions versus number of iterations: a) f_1 ; b) f_2 ; c) $F = f_1 + f_2$; d) zoom of F .

7. Conclusion

In this paper, a multi-objective optimal design procedure is outlined by discussing optimality criteria and numerical aspects. In particular, optimality criteria have been chosen according to the most common design requirements for robotic systems by paying special attention to stiffness, since it is of primary importance in order to guarantee the successful use of any robotic system for a given task. Additional alternative objective functions can be used to extend the proposed design procedure to more general design problems. The feasibility of such a complex design formulation for robotic manipulators has been illustrated by referring to experiences that have been developed at LARM in Cassino.

8. Acknowledgements

The author wishes to thank Prof. Marco Ceccarelli at LARM in Cassino for his valuable comments and support during the elaboration of this work.

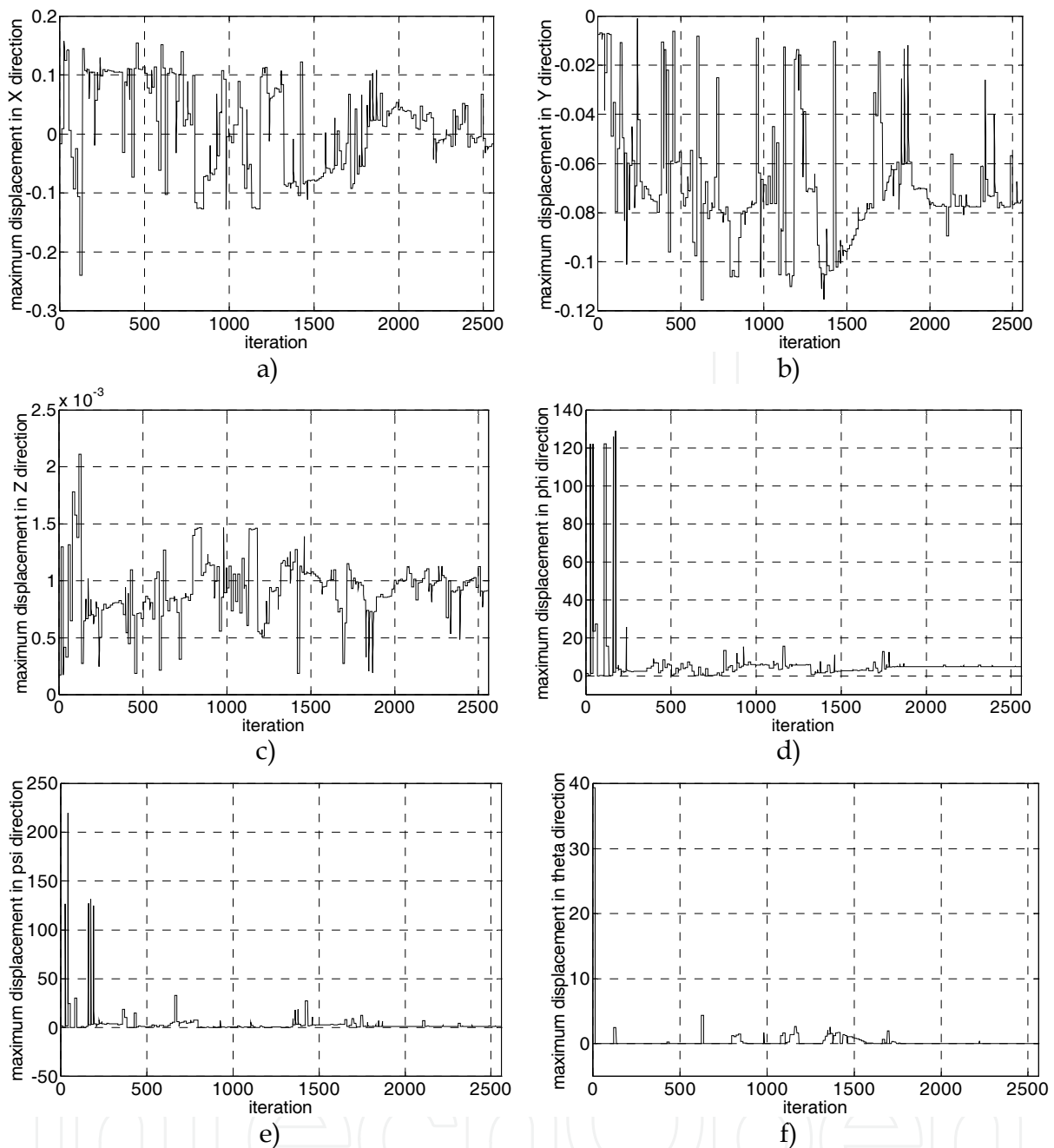

Fig. 17. Compliant displacements in [mm] and [deg] versus number of iterations: a) U_x ; b) U_y ; c) U_z ; d) U_ϕ ; e) U_ψ ; f) U_θ .

9. References

- Alici G. & Shirinzadeh B. (2003). Exact stiffness analysis and mapping for a 3-SPS+S parallel manipulator. *Proceedings of the 7th International Conference on Automation Technology AUTOMATION 2003, Taiwan*, paper F120.
- Angeles, J. (2002). The Robust Design of Parallel Manipulators. *Proceedings of 1st International Colloquium Collaborative Research Center 562, Braunschweig*, pp. 9-30.

- ANSI, American National Standards Institute (1990). American National Standard for Industrial Robots and Robot Systems: Point-to-Point and Static Performance Characteristics – Evaluation. *ANSI/RIA 15.05-1-1990*, New York.
- Boyd, S., & Vandenberghe, L. (2004). *Convex Optimization*. Cambridge University Press. Available on line at <http://www.stanford.edu/~boyd/cvxbook/>.
- Branke J. (2008). *Multiobjective optimization: interactive and evolutionary approaches*, Springer Verlag.
- Castejón C., Carbone G., García-Prada J.C., Ceccarelli M. (2007). A Multi-Objective Optimization Design for a 4R Service Robot, *International Journal of Mechanics and Control*, vol.08, n.02, pp.3-8.
- Carbone G. (2003). *Stiffness Evaluation of Multibody Robotic Systems*. PhD Dissertation, LARM, University of Cassino, Cassino.
- Carbone G. (2006). Stiffness Performance of Multibody Robotic Systems. *Proceedings of IEEE-TTTC International Conference on Automation, Quality&Testing, Robotics AQTR 2006*, vol.2, pp.219-224, Cluj-Napoca.
- Carbone G., Ceccarelli M., Ogura Y., Lim H.O., Takanishi A. (2003). Numerical Simulation for an Optimum Design of a Humanoid Leg Through Stiffness Analysis. *Proceedings of 3rd IEEE International Conference on Humanoid Robots HUMANOIDS2003*, München and Karlsruhe, paper 3bWalking03.
- Carbone G., Ottaviano E., Ceccarelli M. (2007). An Optimum Design Procedure for Both Serial and Parallel Manipulators”, *IMechE Part C: Journal of Mechanical Engineering Science*, vol.221, n.7, pp.829-843.
- Ceccarelli, M. (2004). *Fundamentals of Mechanics of Robotic Manipulation*, Kluwer, Dordrecht, 2004.
- Ceccarelli, M., Carbone, G. (2002). A Stiffness Analysis for CaPaMan (Cassino Parallel Manipulator), *Mechanism and Machine Theory*, vol.37, n.5, pp.427-439.
- Duffy, J. (1996). *Statics and Kinematics with Applications to Robotics*, Cambridge University Press, 153-169.
- Eldar, Y.C. (2006). Minimax estimation of deterministic parameters in linear models with a random model matrix, *IEEE Transactions on Signal Processing*, Vol. 54, No. 2, pp. 601-612.
- English C.E., Russell D. (1999). Mechanics and Stiffness Limitations of a Variable Stiffness Actuator for Use in Prosthetic Limbs. *Mechanism and Machine Theory*, vol.34, n.1, pp.7-25.
- Gosselin, C. (1990). Stiffness Mapping for Parallel Manipulators”, *IEEE Transactions on Robotics and Automation*, 6(3):.377-382.
- Gosselin C., Angeles J. A Global Performance Index for the Kinematic Optimization of Robotic Manipulators, *Transaction of the ASME Journal of Mechanical Design*, 113: 220-226, 1991.
- Grace, A. (1992). *Optimization Toolbox User’s Guide*, The Matlab Works Inc..
- Hao, F., & Merlet, J.-P. (2005). Multi-Criteria Optimal Design of Parallel Manipulators Based on Interval Analysis, *Mechanism and Machine Theory*, Vol. 40, 2005, pp. 157-171.
- Kardestuncer, H. (1974). *Elementary Matrix Analysis of Structures*, McGraw-Hill Kogakusha, Tokyo.
- Manoochehri, S., & Seireg, A.A. (1990). A Computer-Based Methodology for the Form Synthesis and Optimal Design of Robot Manipulators, *ASME Journal of Mechanical Design*, Vol. 112, pp. 501-508.
- Mathworks webpage (2009). Optimization toolbox™ 4. User guide. available on-line at http://www.mathworks.com/access/helpdesk/help/pdf_doc/optim/optim_tb.pdf.

- Merlet, J.-P. (2004). A C++ algorithms library of interval analysis for equation systems, version 2.3, COPRIN project, available on-line at <http://www-sop.inria.fr/coprin/equipe/merlet/merlet.html>
- Merlet, J.-P. (2006). *Parallel Robots*. Springer Verlag.
- Nof S.Y. (1985). Handbook of Industrial Robotics. *John Wiley & Sons*, New York.
- Ottaviano, E., & Carbone G. (2003). A Procedure for the Multiobjective Design of Parallel Manipulators, *International Journal of Mechanics and Control*, Vol.04, No. 02, pp.57-62.
- Ottaviano, E., & Ceccarelli, M. (2002). Optimum Design of Parallel Manipulators for Workspace and Singularity Performances, *Workshop on Fundamental Issues and Future Research Directions for Parallel Mechanisms and Manipulators*, Quebec City, pp.98-105.
- Paden, B., & Sastry, S. (1988). Optimal Kinematic Design of 6R Manipulators, *International Journal of Robotics Research*, Vol.7, No. 2, pp. 43-61.
- Pankov, A.R., Platonov, E.N., & Siemenikhin, K.V. (2000). On Minimax Identification: Method of Dual Optimization, *Proceedings of 39th IEEE Conference on Decision and Control*, Sydney, Vol. 5, pp. 4759-4764.
- Rivin, E.I. (1999). *Stiffness and Damping in Mechanical Design*, Marcel Dekker.
- Shimano, B.E., & Roth, B. (1978). Dimensional Synthesis of Manipulators, *Proceedings of 3rd RoManSy*, pp.166-187, Udine.
- Schimmels J.M. (2001). Multidirectional Compliance and Constraint for Improved Robotic Deburring. Part 1: Improved Positioning. *Robotics and Computer-Integrated Manufacturing*, vol.17, n.4, pp.277-286.
- Schonherr, J. (2000). Evaluation and Optimum Design of Parallel Manipulators Having Defined Workspace, *Proceedings of ASME 26th Biennial Mechanisms and Robotics Conference*, Baltimore, Paper DETC2000/MECH-14092.
- Tahmasebi F., Tsai L.W. (1992). Jacobian and Stiffness Analysis of a Novel Class of Six-Dof Parallel Minimanipulators. *Proceedings of the ASME 22nd Biennial Mechanism Conference*, New York, vol.47, pp. 95-102.
- Takeda, Y., & Funabashi, H. (1999). Kinematic Synthesis of In-Parallel Actuated Mechanisms Based on the Global Isotropy Index", *Journal of Robotics and Mechatronics*, Vol. 11, No. 5, pp. 404-410.
- Tsai, L.W. (1999). *Robot Analysis: the Mechanics of Serial and Parallel Manipulators*, John Wiley & Sons, New York, pp.260-297.
- Tsumugiwa T., Yokogawa R., Hara K. (2002). Variable Impedance Control with Virtual Stiffness for Human-Robot Cooperative Peg-in-Hole Task. *Proceedings of the IEEE/RSJ International Conference on Intelligent Robots and Systems IROS'02*, Lausanne, pp.1075-1081.
- Yao S., Zhan Q., Ceccarelli M., Carbone G., Lu Z. (2009). Analysis and Optimal Design of a Modular Underactuated Mechanism for Robot Fingers", *IEEE/RSJ International Conference on Intelligent Robots and Systems IROS'09*, St. Luis.
- UNI, Italian National Institute for Standards (1995). Manipulating Industrial Robots: Performance Criteria and Related Test Methods. *UNI EN 29283 (= ISO 9283)*, Milan.
- Vanderplaats, G. (1984). *Numerical Optimization Techniques for Engineers Design*, McGraw-Hill, New York.
- Vijaykumar, R., Waldron, K.J., & Tsai, M.J. (1986). Geometric Optimization of Serial Chain Manipulator Structures for Working Volume and Dexterity, *International Journal of Robotics Research*, Vol.5, No. 2, pp. 91-103.



Robot Manipulators New Achievements

Edited by Aleksandar Lazinica and Hiroyuki Kawai

ISBN 978-953-307-090-2

Hard cover, 718 pages

Publisher InTech

Published online 01, April, 2010

Published in print edition April, 2010

Robot manipulators are developing more in the direction of industrial robots than of human workers. Recently, the applications of robot manipulators are spreading their focus, for example Da Vinci as a medical robot, ASIMO as a humanoid robot and so on. There are many research topics within the field of robot manipulators, e.g. motion planning, cooperation with a human, and fusion with external sensors like vision, haptic and force, etc. Moreover, these include both technical problems in the industry and theoretical problems in the academic fields. This book is a collection of papers presenting the latest research issues from around the world.

How to reference

In order to correctly reference this scholarly work, feel free to copy and paste the following:

Carbone Giuseppe (2010). Stiffness Analysis for an Optimal Design of Multibody Robotic Systems, Robot Manipulators New Achievements, Aleksandar Lazinica and Hiroyuki Kawai (Ed.), ISBN: 978-953-307-090-2, InTech, Available from: <http://www.intechopen.com/books/robot-manipulators-new-achievements/stiffness-analysis-for-an-optimal-design-of-multibody-robotic-systems>

INTECH
open science | open minds

InTech Europe

University Campus STeP Ri
Slavka Krautzeka 83/A
51000 Rijeka, Croatia
Phone: +385 (51) 770 447
Fax: +385 (51) 686 166
www.intechopen.com

InTech China

Unit 405, Office Block, Hotel Equatorial Shanghai
No.65, Yan An Road (West), Shanghai, 200040, China
中国上海市延安西路65号上海国际贵都大饭店办公楼405单元
Phone: +86-21-62489820
Fax: +86-21-62489821

© 2010 The Author(s). Licensee IntechOpen. This chapter is distributed under the terms of the [Creative Commons Attribution-NonCommercial-ShareAlike-3.0 License](#), which permits use, distribution and reproduction for non-commercial purposes, provided the original is properly cited and derivative works building on this content are distributed under the same license.

IntechOpen

IntechOpen