

# We are IntechOpen, the world's leading publisher of Open Access books Built by scientists, for scientists

4,800

Open access books available

122,000

International authors and editors

135M

Downloads

Our authors are among the

154

Countries delivered to

TOP 1%

most cited scientists

12.2%

Contributors from top 500 universities



WEB OF SCIENCE™

Selection of our books indexed in the Book Citation Index  
in Web of Science™ Core Collection (BKCI)

Interested in publishing with us?  
Contact [book.department@intechopen.com](mailto:book.department@intechopen.com)

Numbers displayed above are based on latest data collected.  
For more information visit [www.intechopen.com](http://www.intechopen.com)



## Methodology for Part Visualization Problem Solving - the Importance of the Process -

E. Sierra Uria<sup>1</sup> and M. Garmendia Mugika<sup>2</sup>

<sup>1</sup>Faculty of engineering of Bilbao, The University of the Basque Country, Bilbao, Basque Country, egoitz.sierra@ehu.es;

<sup>2</sup>University School Technical of San Sebastián, The University of the Basque Country, San Sebastián, Basque Country, mikel.garmendia@ehu.es

### Abstract

Part visualization is a fundamental skill in engineering. It comprises the reading, interpretation and creation of industrial technical drawings, understanding the different views (multi-view) of an object/piece represented in any technical drawing.

The ability to mentally visualize and manipulate objects and situations is an essential need in many jobs and careers. It is estimated that at least 84 majors consider visualization a fundamental need, and in technical jobs, many of them related to the different types of engineering, the ability to visualize has a crucial importance.

Educators have often pointed out the difficulties of most students in graphic courses when trying to visualize an object using multi-view drawings. This is mainly due to the inexistence of a systematic process to analyze complex forms.

A thorough review of the literature in technical drawing textbooks has not been successful in finding a clear, concise, and properly developed method of solving visualization problems by means of procedural contents.

In collaboration with several experts and for the first time, a problem solving model for visualization has been designed and developed for all kind of industrial objects (**Methodology for Part Visualization Problem Solving**) within a constructivist didactic framework. This Problem Solving model is the key to all technical knowledge and is an application of the scientific method.

In order to solve visualization problems in any kind of industrial object, comprehension indicators have been defined and a Teaching Unit has been developed with the help of dynamic images (power point and CAD files) as well as physical models. They may be applied by drawing up a programme of specific tasks which takes into account the theoretical contents and procedures involved in part visualization as well as the students' main difficulties and deficiencies when faced with this kind of problem.

This teaching strategy has been applied over the last two years in the first year of Industrial Engineering at the Department of Engineering in Bilbao at the University of the Basque Country with good results.

**Topics covered by the book include, but are not limited to:**

Research and Innovation in Education

Curriculum Design and Innovation

*Keywords: part visualization, teaching strategy, problem solving model, constructivism***1. Reasons for this Teaching Strategy?**

There are three main reasons supporting this new teaching strategy:

First, in the different subjects studied by future Engineers, some difficulties can be observed in the visualization of parts and the development of spatial capacities (Sierra Uria, Egoitz, 2005) [1]. Second, the ability to mentally visualize and manipulate objects and situations constitutes an essential need in many engineering-related jobs. It is estimated that nowadays, at least 84 majors consider spatial visualization a fundamental need (Smith, 1964) and in some technical jobs, the ability to visualize has acquired an outstanding importance (Maier, 1994)[2].

And third, the need for this new strategy arises from the educator's need to analyze and continuously assess their own ways of teaching in order to become more effective educators (Fernando Hernandez, 1992) [3].

**2. Didactic Framework**

There is a need to analyze the specific difficulties arising from the learning of visualization. Educators have often pointed out the difficulties shown by most students in graphic courses when trying to visualize an object using multi-view drawings. These difficulties are mainly due to the inexistence of a systematic process to analyze complex forms (Luzzader and Duff 1986) [4].

The didactic strategy followed in most classrooms seems to be one of the main reasons for these difficulties. This didactic strategy consists in a visualization of the problems followed by the solutions to those problems, without providing students with a clear explanation on how to solve them; this is, the necessary reasoning during the problem-solving process (Garmendia, 2004) [5]. Students themselves confirm this lack of a problem-solving strategy. Instead, they use the trial-and-error strategy, or they simply rely on intuition.

Didactic research in problem-solving states that when students reason, different aspects of inter-related knowledge are put to work. A set of general abilities is used and applied to the different aspects of a subject, thus creating particular ways of reasoning in that subject. This proves that in teaching, besides the theoretical and conceptual knowledge, other contents such as procedural knowledge must be taken into consideration (Guisasola et al. 2003) [6].

Certain aspects must be defined when planning the teaching of specific contents and deciding on the design of the learning process through a program of activities. The intended objectives and the contents are among these aspects that ought to be defined, keeping always in mind the possible difficulties that may arise from the assimilation of the contents by the students. But at the same time, it is necessary to define the strategy that will be followed to achieve a meaningful learning, defining a logical sequence of activities specifically designed for the learning process, as well as the type of assessment that will be used to guide the students and help them improve in their learning. We also come across

students who have not developed enough spatial capacity and therefore, they have serious difficulties in understanding and manipulating the parts in space (Navarro,2004) [7]. Mathewson (1999) [8] affirms that educators often forget the importance of the spatial-visualization factor in learning. A review of most text books in this subject shows that little has been done to improve and develop the students' spatial capacity. Engineering textbooks often present orthogonal views, static concepts, theories and ideas with little or no explanation, all of this together with a lack of interpretation of spatial data. It is assumed that the student will be able to overcome the mental challenge and assemble the spatial puzzle.

According to Potter (2003) [9] students with a deficient development of spatial capacity need to learn by using static, dynamic and transformational images, as well as the way to combine them in problem solving. Spatial perception can be developed in many ways. For instance, by practicing the modelling and freehand drawing of objects, representing objects in 3D models, manipulating objects in 3D in order to recreate their representations dimensionally, and finally, by experimenting and working with different perspectives or views of the represented part or object both on the blueprint and in the computer image.

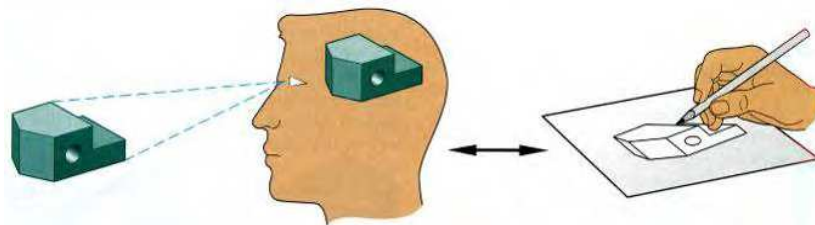

Fig. 1. Bertoline 2003 [10]

On the other hand, a thorough review of the literature in technical drawing textbooks has not been successful in finding a clear, concise, and fully developed method to solve visualization problems using procedural contents. (Sierra Uria, Egoitz, 2005) [1]

## 2.1 Didactic Framework

This Visualization Didactic Unit, together with the programme of task based on the new **Methodology for Part Visualization Problem Solving** has been developed under a constructivist view and within the European Higher Education Framework. The highlights of this framework are the following:

- The student builds up his knowledge
- The new knowledge has to be significant to the student
- The student's previous knowledge must be taken into account
- The teacher must guide students in their learning process
- In the learning process, some "cognitive conflicts" are bound to arise
- The learning process will promote "zone of proximal development" [11] between the students
- The student's work is measured by the ECTS (European Credit Transfer System)
- The students will know at all times the result of their effort and their progress in the learning process, as well as the reward corresponding to their effort (evaluation)
- The student holds the main responsibility for his own learning

## 2.2 Used Tools

Nowadays, ICT (Information and Communication Technology) offers a variety of complementary tools that are very helpful in the teaching/learning of every subject, including the visualization of parts. The tools used in this Visualization Didactic Unit are the following:

### 2.2.1 Slide animation

By using a computer (PC) with a screen output connected to a projector we can easily modify slides and go up and down in the solving process. These slides can also have attached photos and other documents such as videos and CAD models.

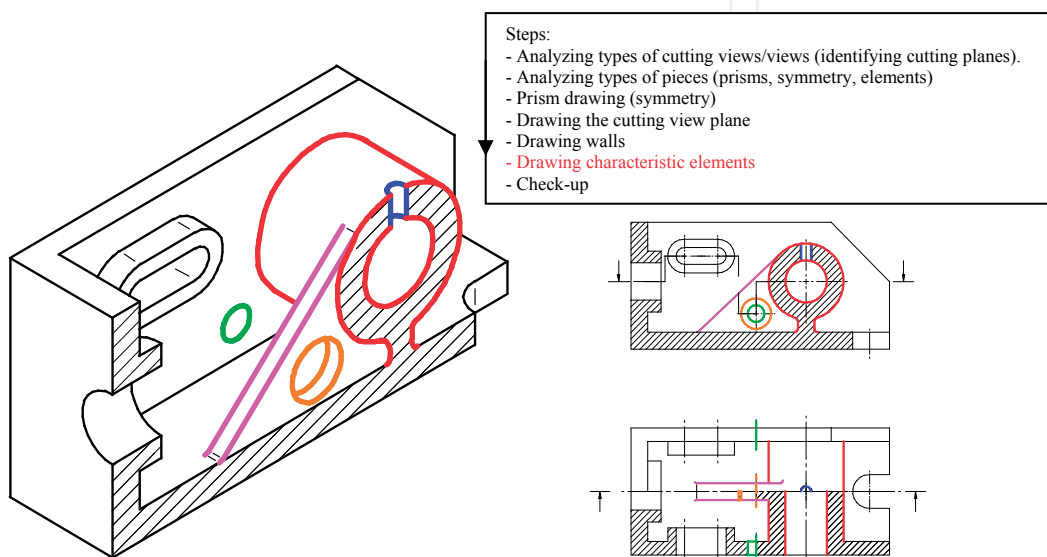

Fig. 2. Slide 6 of 7 from the solving process

### 2.2.2 Virtual models (CAD)

Virtual models created by computers with a CAD program can be easily rotated and sectioned in any moment depending on the teacher's or student's needs. We can move from a perspective to multi-views or vice versa quickly. In this way, the difficulties arising from the understanding of the relationship between the spatial reality of a part and its representation on the technical drawing are minimized.



Fig. 3. CAD virtual model

### 2.2.3 Physical models (CAD)

According to a number of authors, in order to increase the spatial capacity of students it is necessary to work in space with 3D models which can be turned, moved, and worked on mentally, for example, by obtaining their projections (Devon et al. 1994). [12]

Following Bertoline et al. (1995) [13], another way of improving the students' ability when visualizing an object or a 3D scene is to make their experience as realistic as possible.



Fig. 4. Physical models

Therefore, real physical models have been used. Some of them are made of cardboard but most of them are made with rapid prototyping machinery in the Product Design Laboratory in Bilbao ([www.ehu.es/PDL/](http://www.ehu.es/PDL/)) at the Department of Graphic Design and Engineering Projects, University of the Basque Country.

## 3. Methodology for Part Visualization Problem Solving, Comprehension Indicators and Activity Program

This newly developed Methodology for Part Visualization Problem Solving is mainly based on three sources:

- The analysis of the students' difficulties when faced with Visualization problems
- The analysis of the experts' solutions to Visualization problems
- The analysis of textbooks and published research papers in the area of Engineering Graphics and Engineering Education

In this new Methodology [14] the Problem Solving model has become the key to articulate all the necessary knowledge for the the solving of this kind of problems. The Problem Solving model, which is an application of the scientific method, constitutes the basis of all technical knowledge.

When faced with a Visualization Problem, the data (multi-views) must first be analyzed and, according to these analyzed data, a strategy must be decided on. The problem can be solved element by element (sub-problems), by drawing a sketch and checking its concordance with the data. In an iterative process, all the elements of the object must be solved. Once the whole object is obtained, new views/cutting views can be created using the same method (analyzing the new viewpoint / cut viewpoint and then, solving element by element).

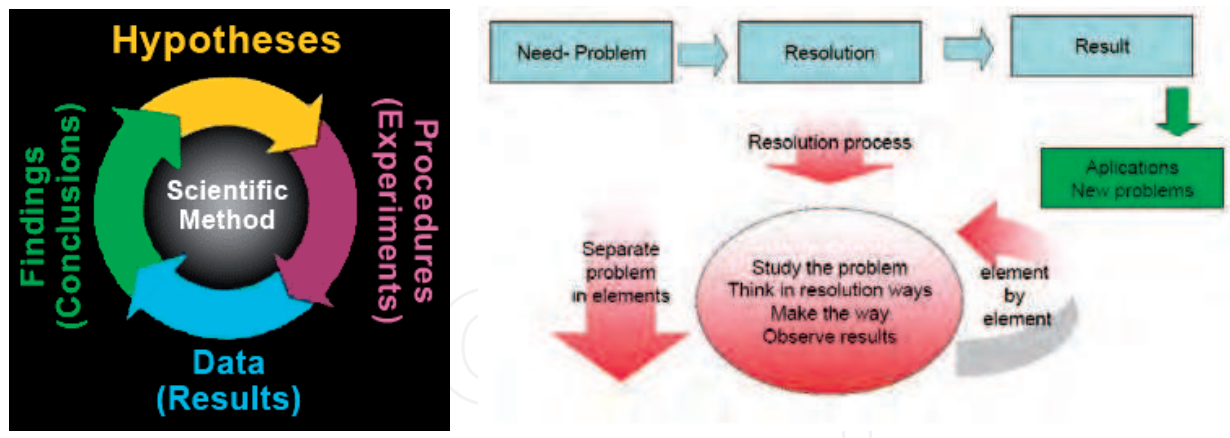

Fig. 5. Scientific method and Problem Solving Model

### 3.1 Comprehension indicators

In order to solve the visualization problems in any kind of industrial object, the following comprehension indicators must be mastered. The first eight indicators basically correspond to conceptual knowledge and the last two indicators, while containing conceptual skills, correspond essentially to procedural knowledge.

#### 3.1.1 Fundamentals of representation systems

These fundamentals consist of a sound knowledge of the basics of the main representation system of the orthogonal cylindrical projection (multi-view), including standardization, and how projections are created (from 3D to 2D) as well as the reason for visible and hidden lines.

Another important aspect is achieving a sound knowledge of the basics and main features of the axonometric perspective and oblique projections (3D).

To visualize the piece in space (3D) it is necessary to proceed in reverse to what has been done to create the views (2D). There should be a good knowledge of the relationship between the systems of representation.

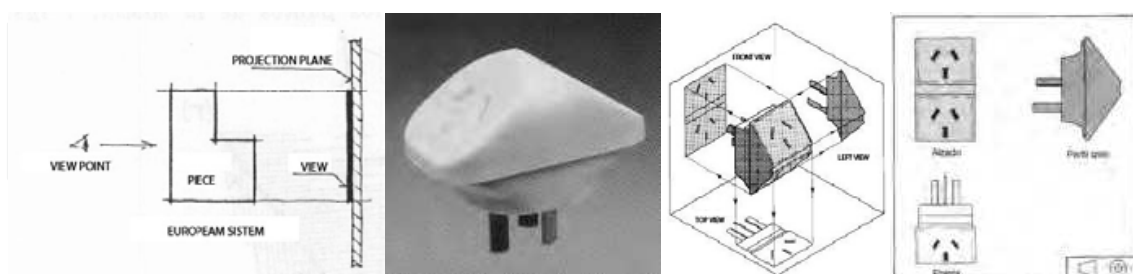

Fig. 6. Fundamentals of multiview representation [18]

#### 3.1.2 Conditions or rules of correspondence (6 rules)

The rules derived from the type of projection (parallel projection/cylindrical and orthogonal) must be mastered. This is:

1. The projections of a point will be aligned in the different views.
2. The dimension between two points (x, y, z) will be the same for different views

3. Parallel lines in the different views will remain always parallel.
4. The form of flat surfaces remains equal in the different views unless it is seen as a line. In this case, the surface (plane) is parallel to the visual
5. Two contiguous areas separated by a line cannot be on the same plane
6. The dimension of a feature is in a true scale when it is perpendicular to the visual projection. When it is not perpendicular, it will be smaller than true scale.

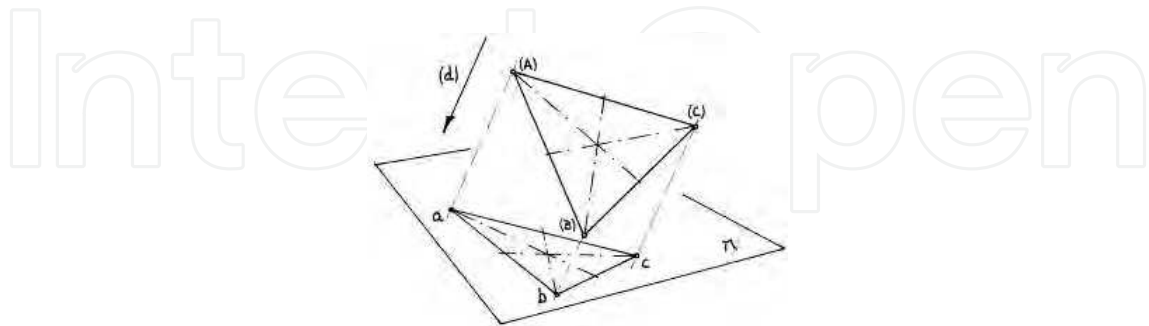

Fig. 7. The form of flat surfaces remains equal but the dimensions are not in true scale unless the feature is parallel to the projection plane

### 3.1.3 Types of planes and characteristics of its projections

There must be a sound knowledge of the different types of planes (3D) according to their relationship with the projection (parallel, project planner and oblique) as well as of the characteristics of their projections (2D).

### 3.1.4 Types of solid primitives and characteristics of its projections

It is necessary to be very well acquainted with the various geometric main elements (3D) and the characteristics of their projections (2D) both when they are solids or surfaces (prism, cube, cylinder, cone, sphere, geometries of revolution).

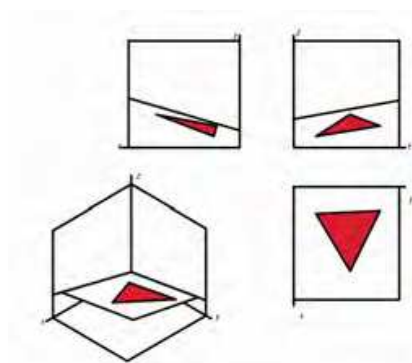

Fig. 8. Oblique plane

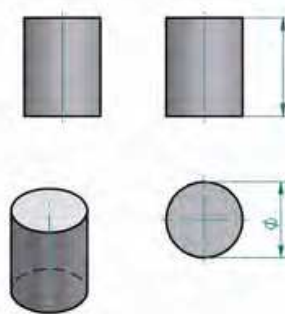

Fig. 9. Cylinder

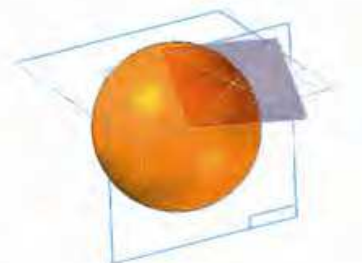

Fig. 10. Sphere

### 3.1.5 Tangency and intersection between surfaces

This means mastering the tangency between surfaces (3D) and their representation (2D) (lines of contact, finite line) as well as the various intersections between surfaces (3D) and their representation in the most basic areas (plane, cylinder, cone, sphere)



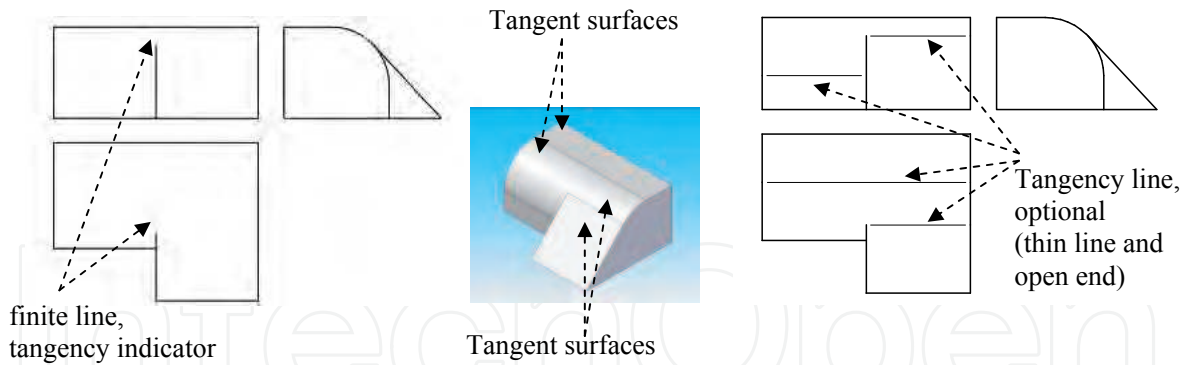

Fig. 11. Tangent surfaces and tangency line

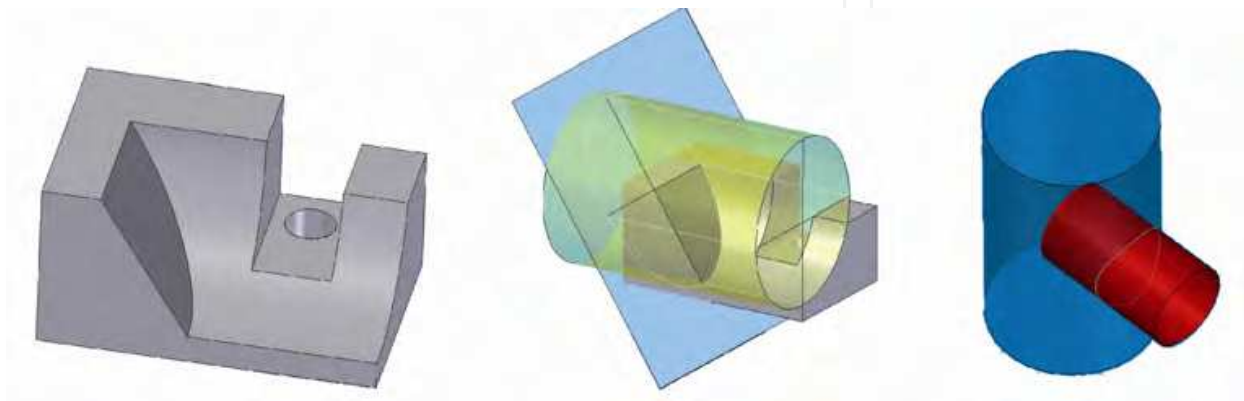

Fig. 12. Intersection between cylinder and plane and between cylinders

**3.1.6 Fundamentals of vacuum (material -)**

This involves having a sound knowledge of reasons for the existence of vacuum and its relationship with the material (3D), as well as knowing how to represent the existing vacuum in the projections (2D) (hidden lines)

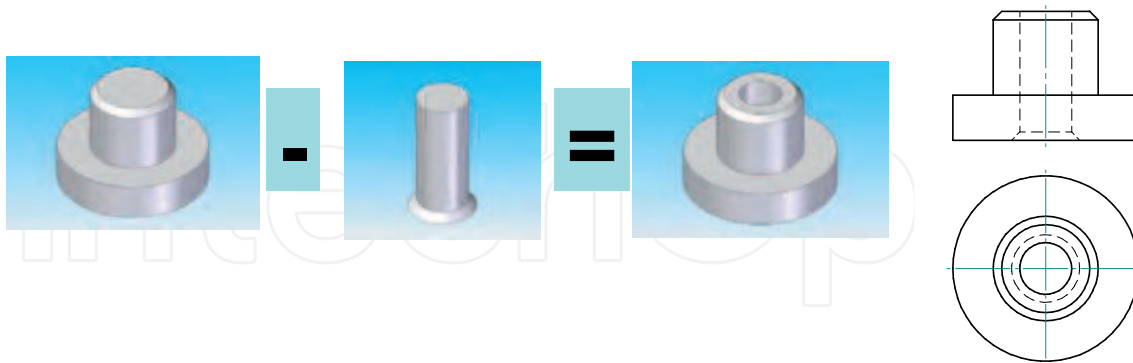

Fig. 13. Vacuum = material (+) - material (-). The vacuum is always surrounded by material

**3.1.7 Fundamentals of cuts and different types of cutting planes**

These fundamentals consist of a good knowledge of the basics of cuts (3D) and their representation (2D), as well as the different types of cutting planes (normal, staggered, aligned, //view //cut)

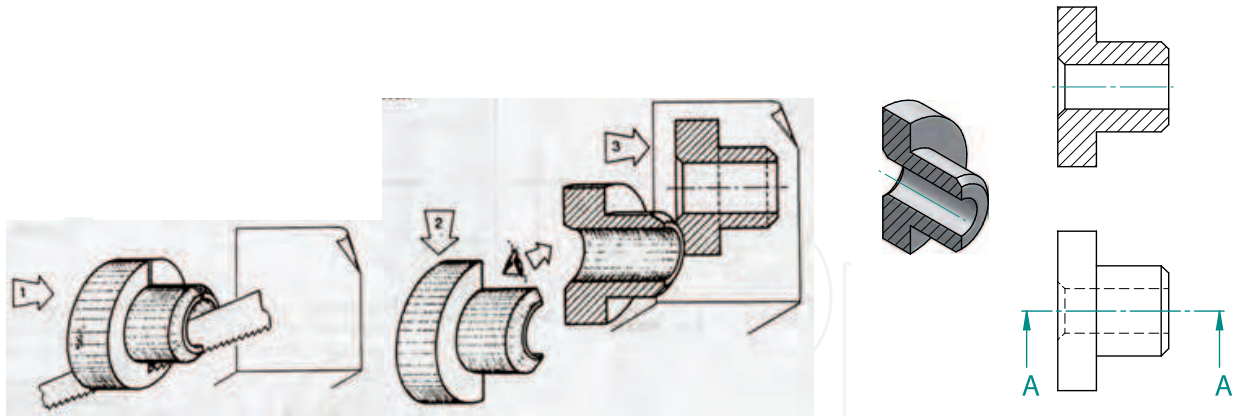

Fig. 14. cutting plane

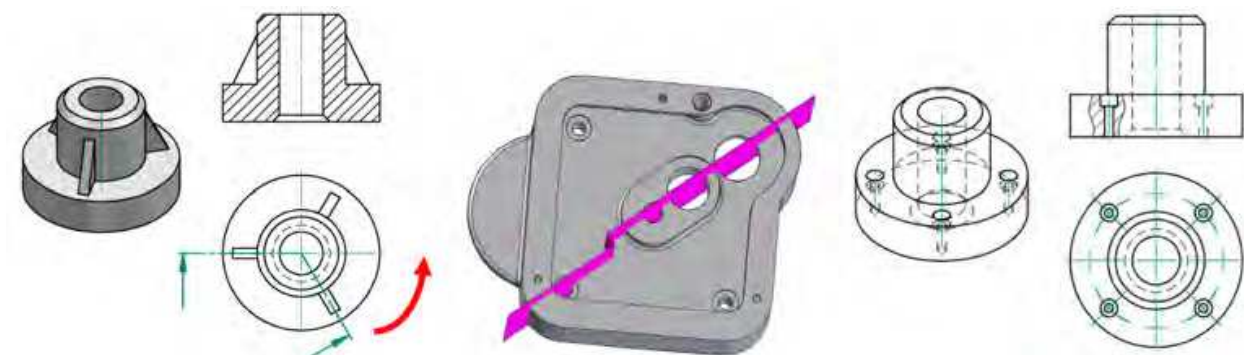

Fig. 15. Example of different cuttings: aligned section, offset section view and broken-out section view

### 3.1.8 Fundamentals of the industry's most characteristic features

This means mastering the most common industrial elements of industrial parts (3D), their characteristics and how to represent them (2D) (all kinds of holes, nerves, rounding off, chamfers...)

IntechOpen

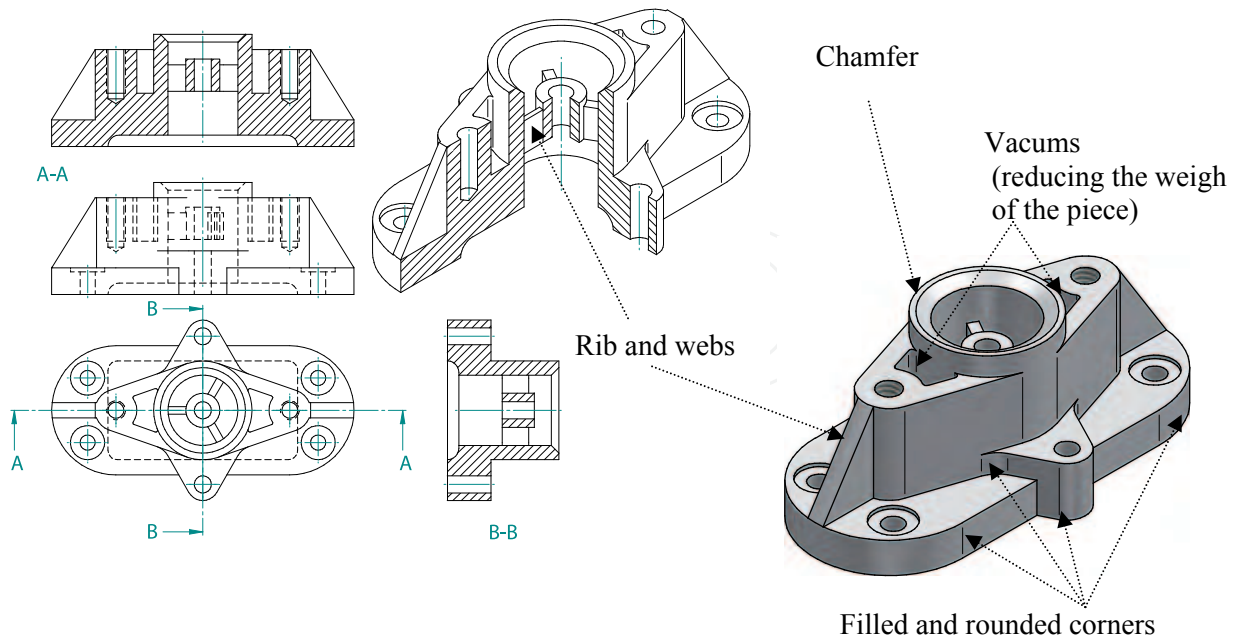

Fig. 16. Piece with several industry's characteristic features

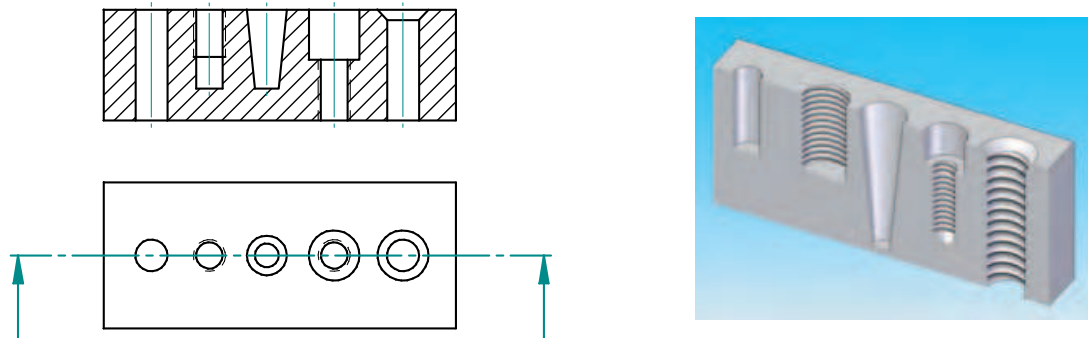

Fig. 17. Holes (drilled, countersunk, counterbored, blind and threaded holes)

### 3.1.9 Fundamentals of sketches

These fundamental involve the process of creating sketches (3D and 2D) keeping the visual, the proportions and the parallels.

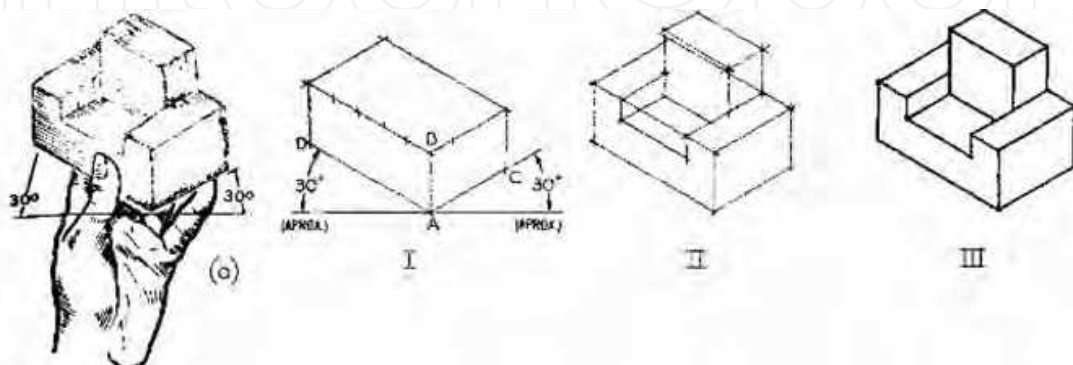

Fig. 18. Sketching process [15]

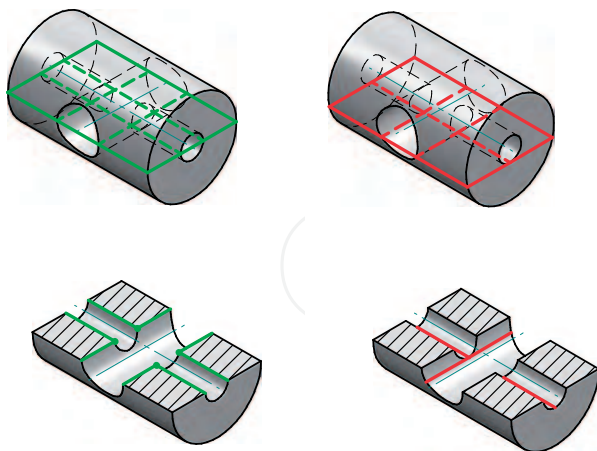

Fig. 19. Cylinder intersection sketching process

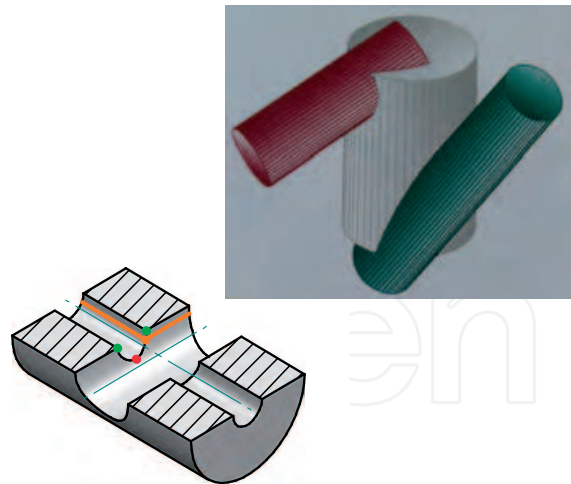

Fig. 20. Bertoline 2003[10]

### 3.1.10 Methodology for Part Visualization Problem Solving and strategies

**Qualitative data analysis.** This involves learning to analyze the data of departure, the type of data and knowing how to interpret the obtained information to classify the types of pieces (solids, surfaces, vertices, features, outside / inside, intersections). This analysis will allow lead to a solution to the problem

**Solving Strategy.** This means choosing the most appropriate solving strategy (specific) according to the analyzed data. It also involves knowing how to validate and raise different hypotheses to solve the visualization of the various elements making up the piece.

- Elimination of volumes
- Decomposing into simple geometric elements

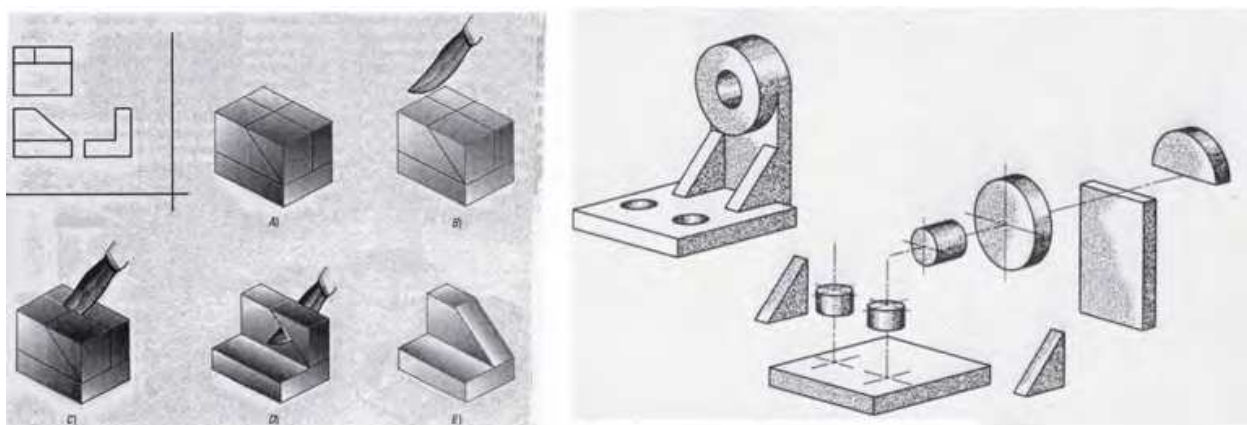

Fig. 21. Elimination [10] and descomposing [21]

- Correspondence Method (identify the different planes): pieces of flat faces

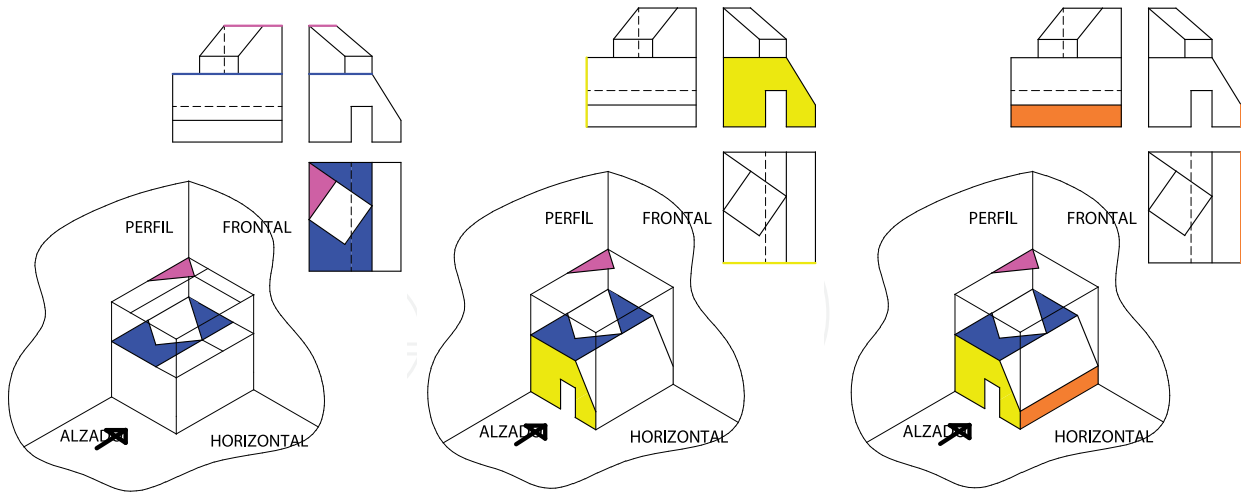

Fig. 22. First steps of solving process, identifying the planes which are parallel to the projection planes

- Identifying the vertices and joining them with the base (figure 23)

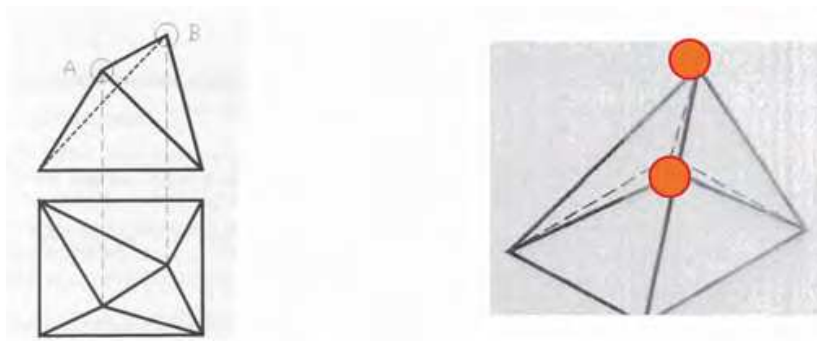

Fig. 23.

- Identifying the geometries of revolution through circles (centers) and axes figure 24)

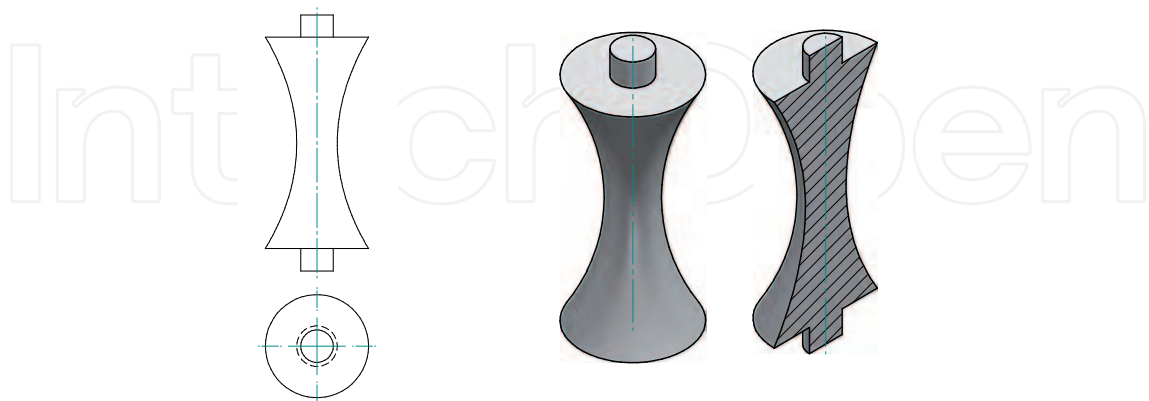

Fig. 24.

- Differentiating between solid geometry (material +) and vacuum (material -) figure 25)

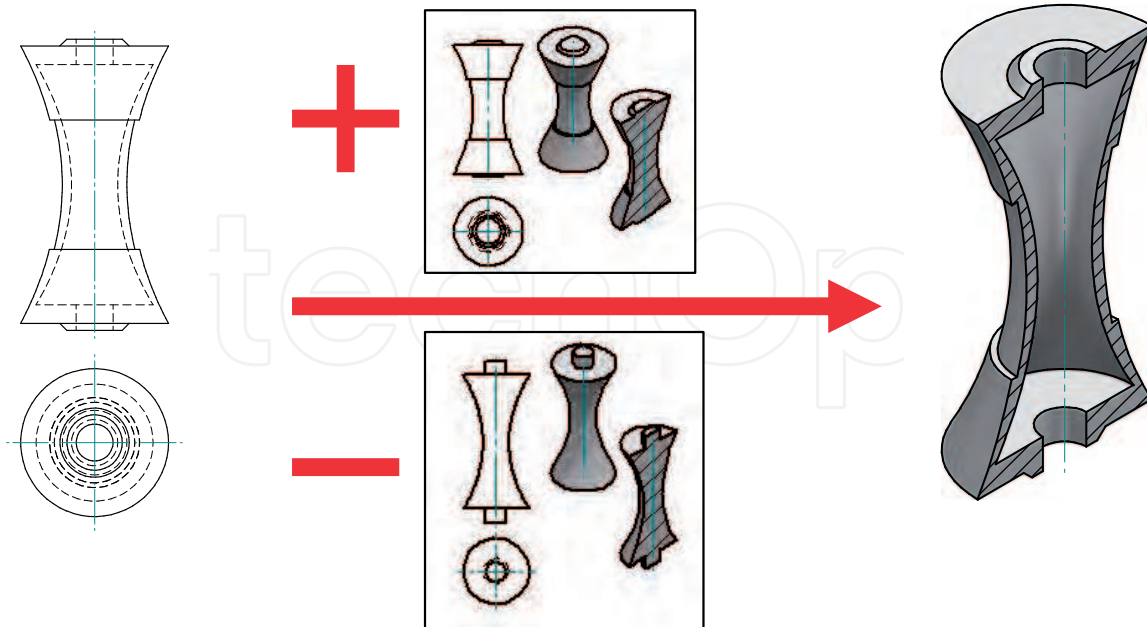

Fig. 25.

- Interpreting the information derived from the most typical Industrial elements (figure 26)

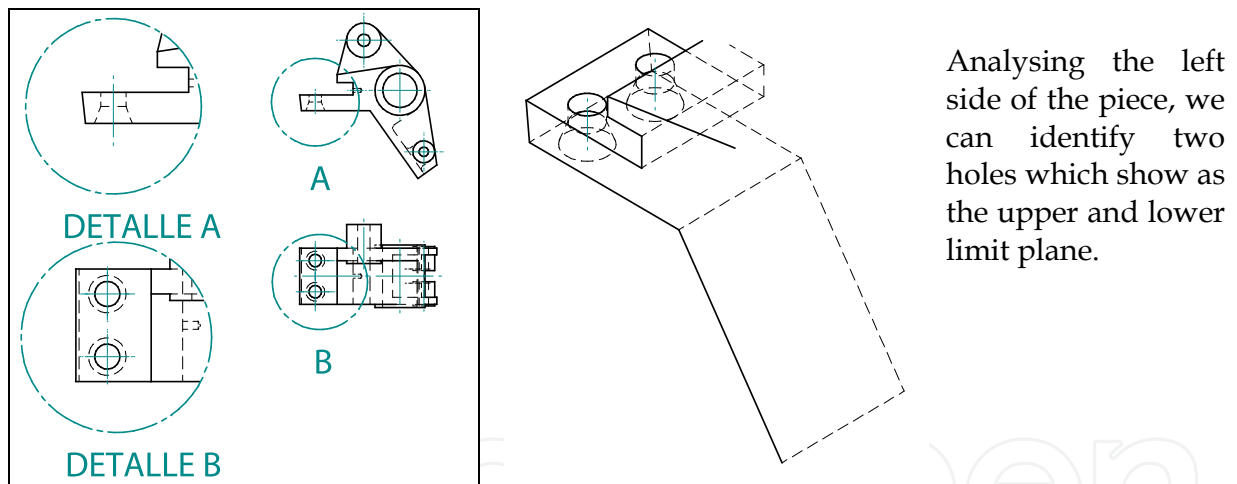

Fig. 26.

- Using the cutting (data) as a reference in the sketch (figure 27)

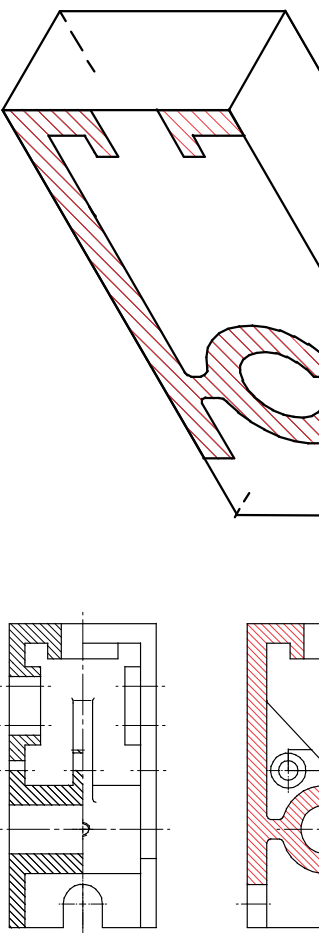

Fig. 27.

In order to solve the piece, an iterative process must be followed to solve all the elements of the piece in a logical sequence.

### 3.2 "Spatial Visualization"

This capacity, which can be defined as the skill to manipulate images mentally, is an essential capacity when trying to solve a visualization problem. This teaching unit makes a very specific effort to attain the necessary level of this skill.

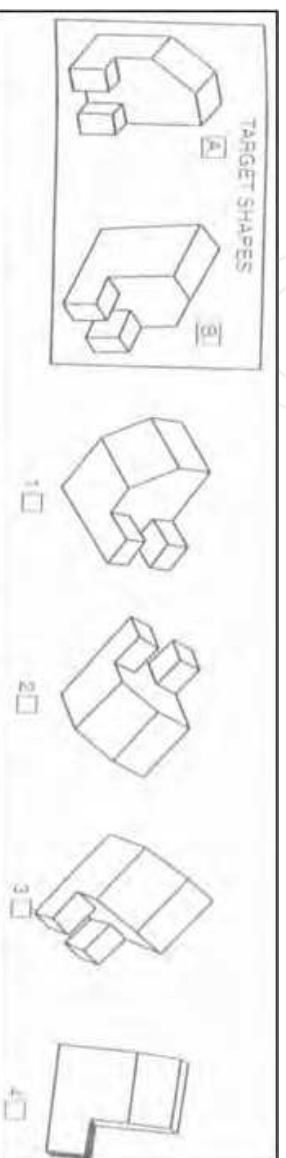

Fig. 28. Spatial Visualization fast exercises [10]

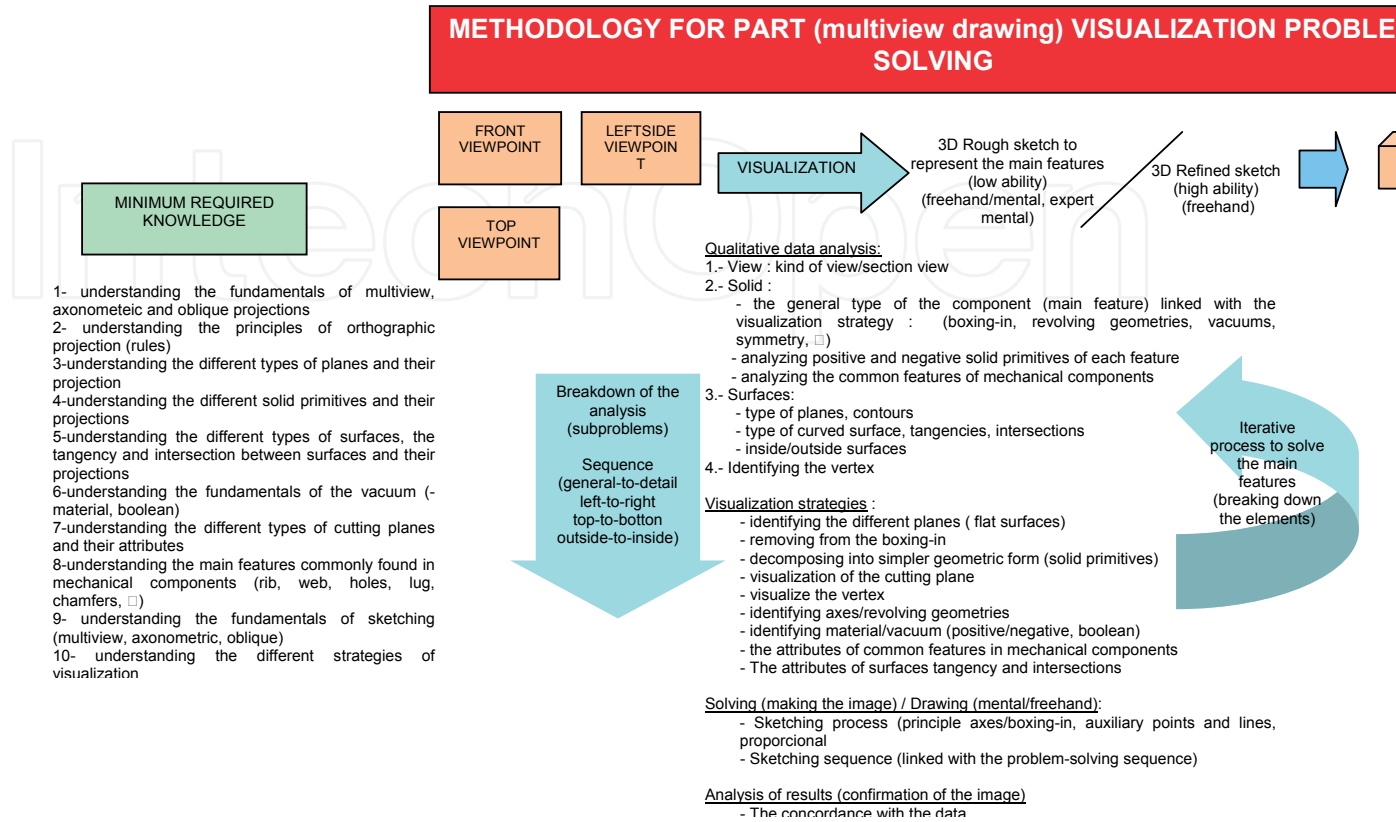

Fig. 29. Methodology for Part Visualization Problem Solving



### 4. Program of Activities

As progress is made in the teaching unit and in order to assimilate the knowledge, the corresponding activities marked by the program must be carried out. The degree of difficulty of each the activities is directly related to the step to be accomplished in the corresponding didactic unit.

Steps to follow

Step	Indicator to work	Carry Out Indicators	Dimensions	Types of activity
1	1 Spatial Visualization	1, 4, 9 Spatial Visualization	2D and 3D From 3D to 2D	Elements (points, lines, surfaces...) Identifying points of view, creating views, simple sketches Working the spatial visualization (Visualization Test ) [16]

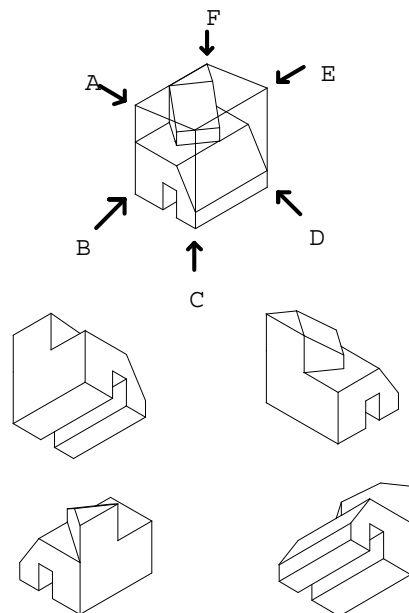
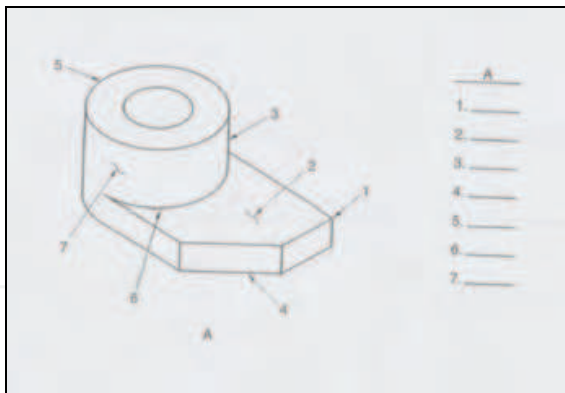

Fig. 30. Identify elements [10] Bertoline and viewpoints

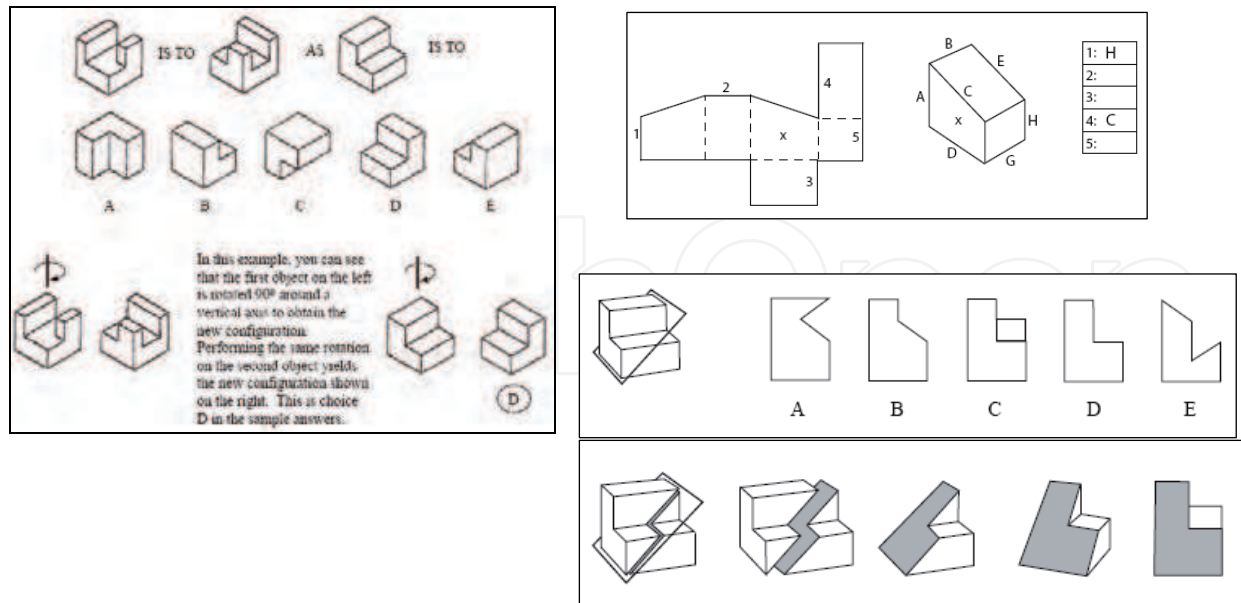

Fig. 31. Rotations, develops and sections from Visualization Test [16]

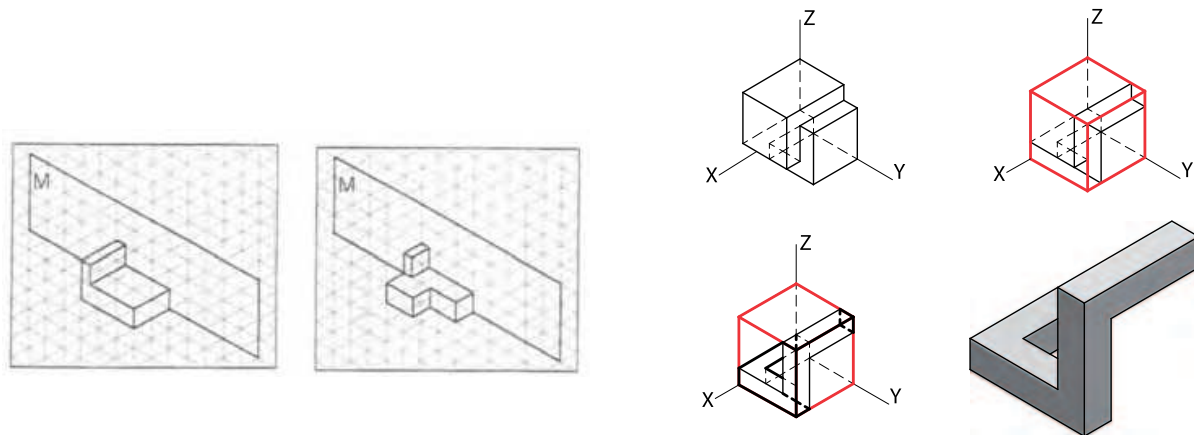

Fig. 32. Easy sketches: mirror [10] and box-in it

Step	Indicator to work	Carry Out Indicators	Dimensions	Types of activity
2	2 and 3	1,2,3,4,9 Spatial Visualization	2D and 3D From 3D to 2D	Plane types, identification of planes Box-plane intersections in axonometric (Sketches)

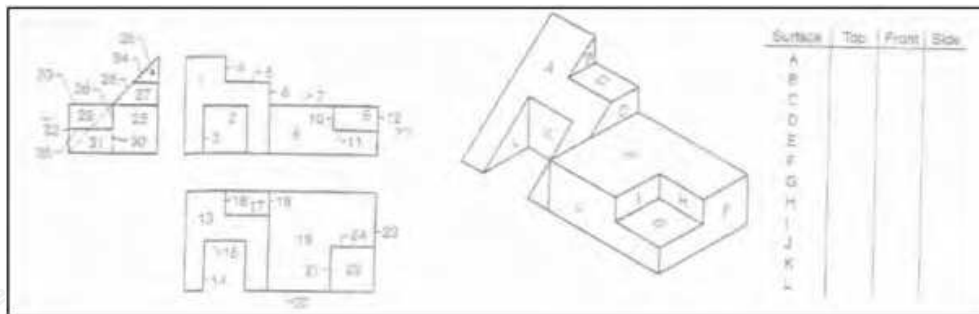

Fig. 33. Identify the different types of planes [10]

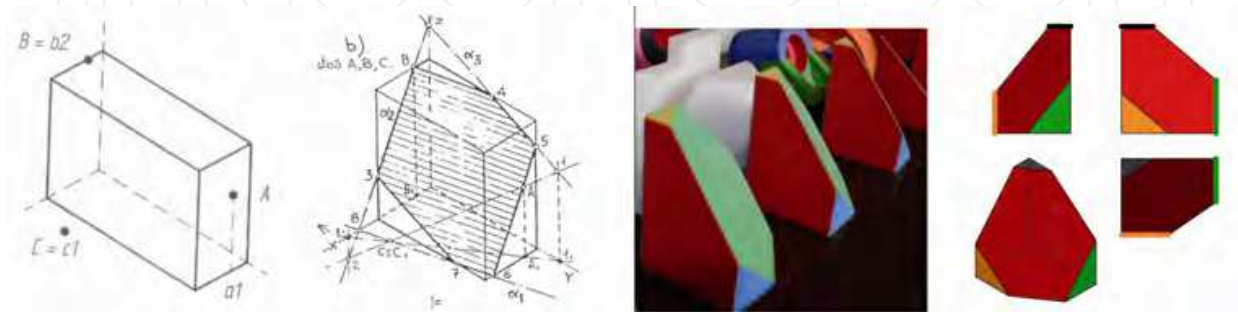

Fig. 34. Box-plane intersections exercise, solution, models and CAD views

Steps	Indicator to work	Carry Out Indicators	Dimensions	Types of activity
3	10 (correspondence)	1,2,3,4,9,10 Spatial Visualization	From 2D to 3D	Solving of pieces with flat faces Sketches

IntechOpen

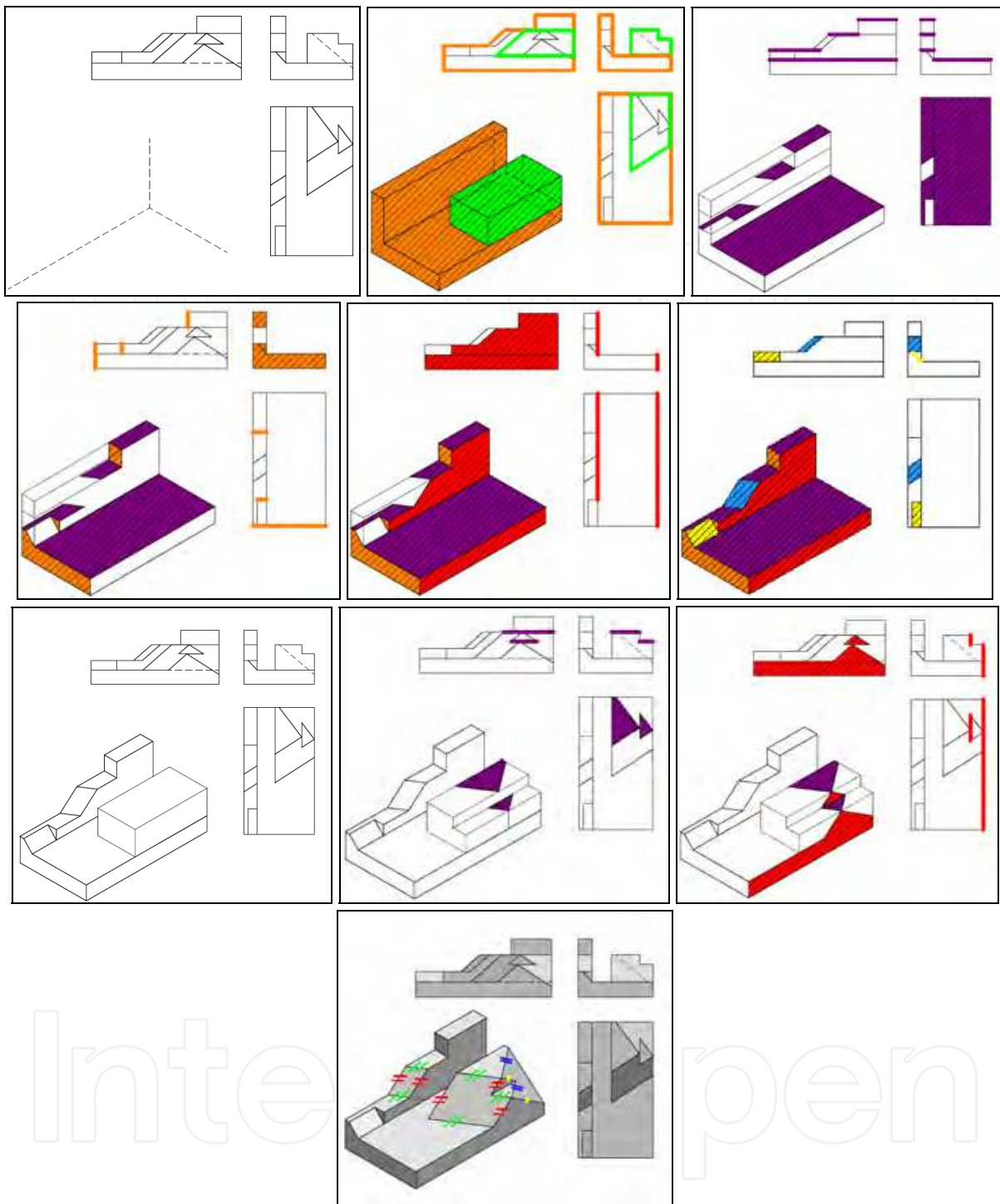

Fig. 35. Example of flat piece resolution process

Steps	Indicator to work	Carry Out Indicators	Dimensions	Types of activity
4	4,5 and 10	1,2,4,5,9,10 Spatial Visualization	From 2D to 3D	Solving of pieces with simple geometric elements Sketches

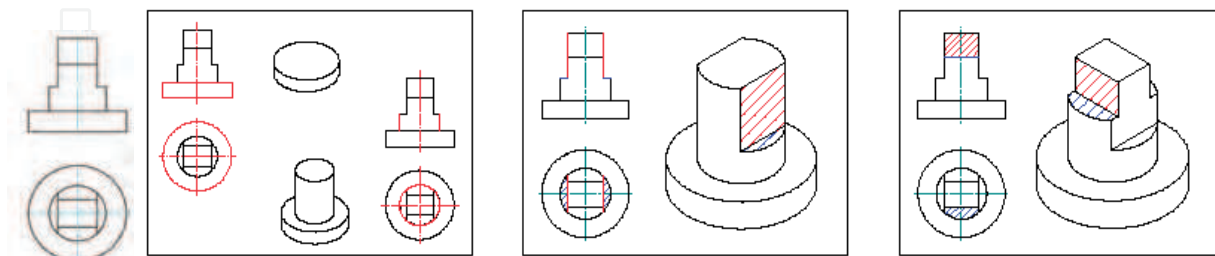

Fig. 36. Example of simple piece resolution process

Steps	Indicator to work	Carry Out Indicators	Dimensions	Types of activity
5	6,7 and 10 Spatial Visualization	1,2,3,4,5,6,7,9,10 Spatial Visualization	From 2D to 3D From 2D to (3D) 2D	Solving of pieces with simple vacuums, drilling exercises Solving of cutting exercises with new views/cuts (Sketches) Spatial visualization (cutting) fast exercises

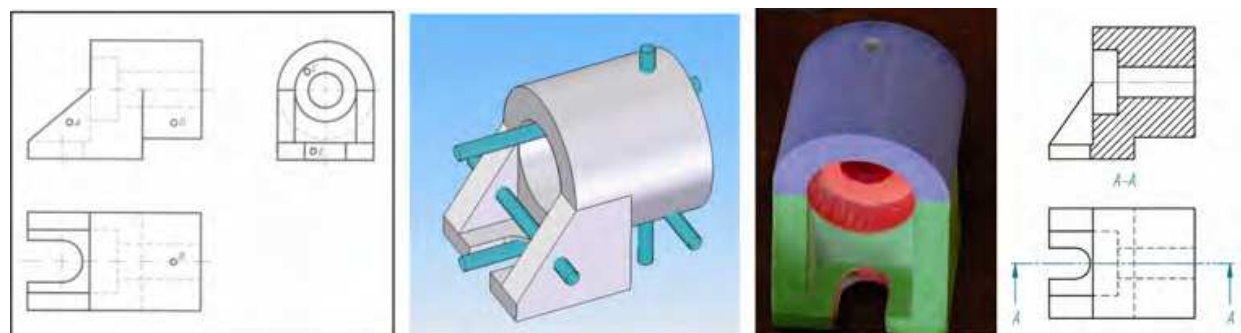

Fig. 37. Example of drilling exercises [20] (student must know when there is material and when there is vacuum) and CAD, physics model and cutting view

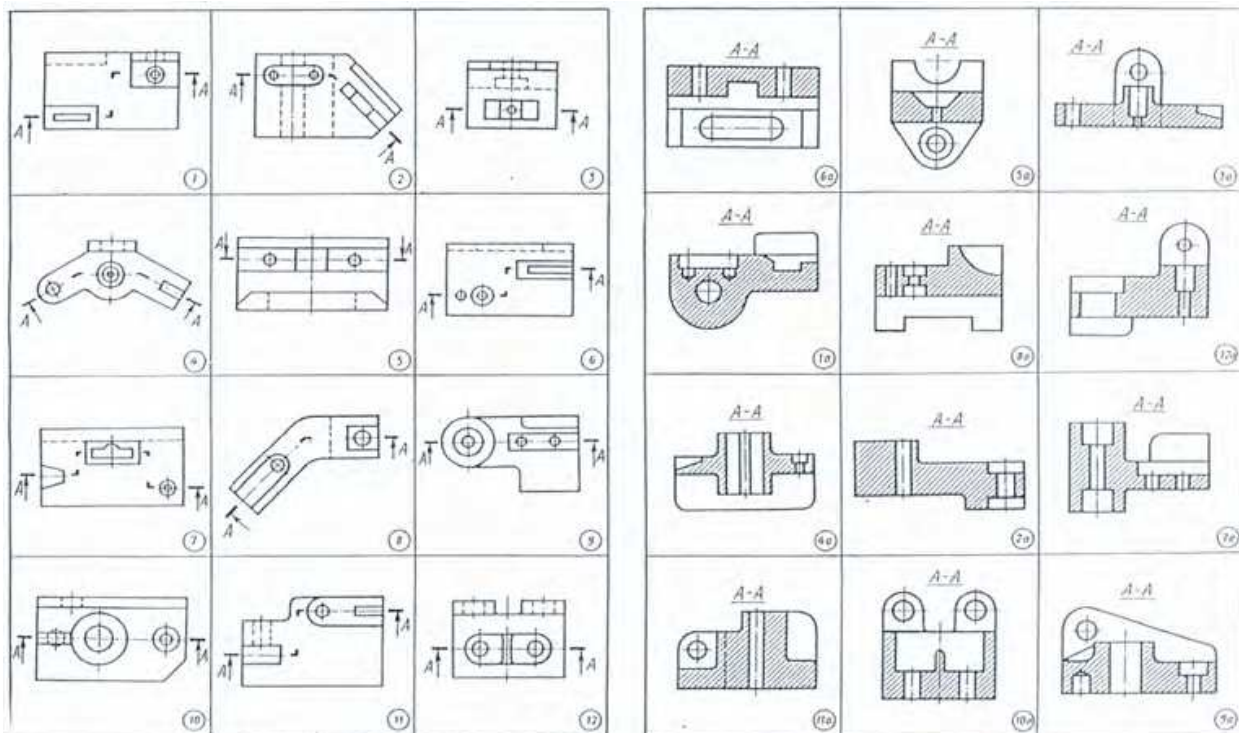

Fig. 38. Example of cutting fast exercise, the student must link the cutting plane and the cutting view [19]

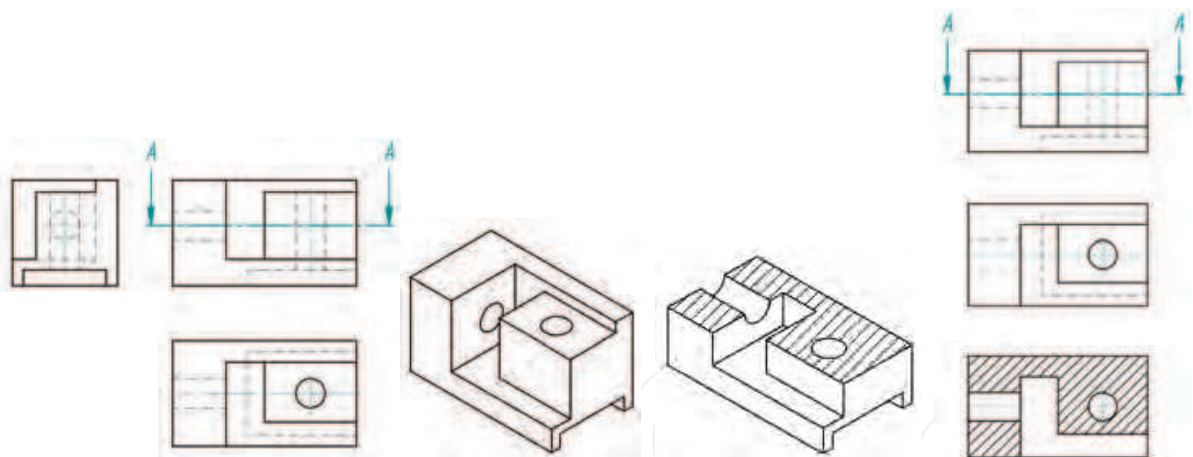

Fig. 39. Example of simple cutting exercise

Steps	Indicator to work	Carry Out Indicators	Dimensions	Types of activity
6	5 and 10	1,2,3,4,5,6,7,9,10 Spatial Visualization	From 2D to 3D From 2D to (3D) 2D	Piece solving with characteristic intersections with new views/cuts (Sketches) Working the spatial visualization (Cutting Visualization Test ) [17]

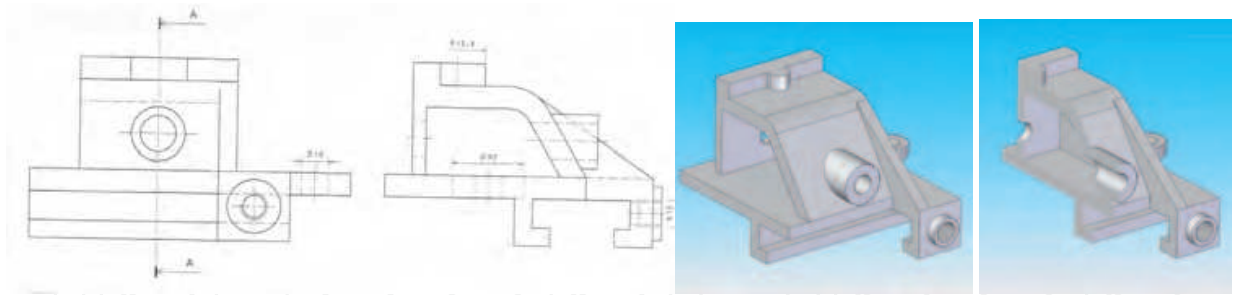
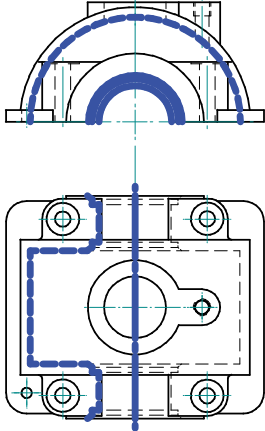
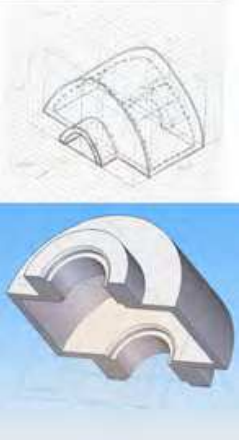
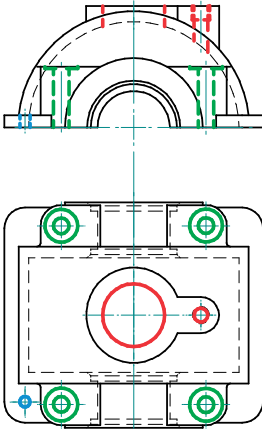
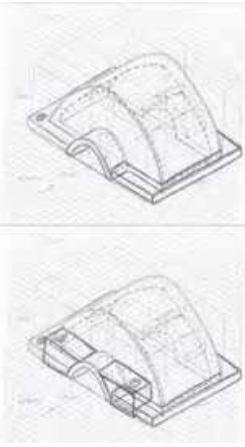
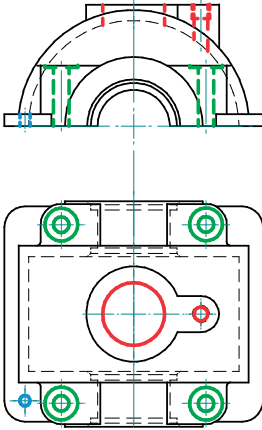
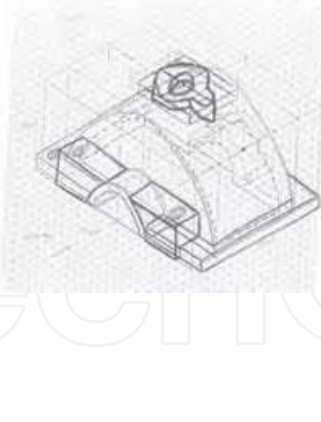
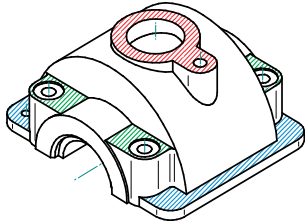

Fig. 40. Example of exercise with intersections between surfaces and CAD models

Table1. Example of resolution process: medium level exercise, the student must sketch the piece

		<ul style="list-style-type: none"> <li>- Analyzing types of cutting views/views</li> <li>- Analyzing types of pieces (prisms, symmetry, elements)</li> <li>- Drawing the boxing-in (symmetry)</li> </ul>
		<ul style="list-style-type: none"> <li>- Identifying revolving axes (material)</li> <li>- Iterative process to solve the main features (breaking down the elements)</li> <li>Solving (making the image) / Drawing (mental/freehand):</li> <li>- Sketching process (principle axes/boxing-in, auxiliary points and lines, proportional)</li> <li>- Sketching sequence (linked with the problem-solving sequence)</li> </ul>

		<ul style="list-style-type: none"> <li>- Identifying revolving axes (-material)</li> <li>- Breakdown of the analysis (sub-problems)</li> </ul> <p>(general-to-detail / left-to-right / top-to-bottom / outside-to-inside)</p>
		<ul style="list-style-type: none"> <li>- Once we have solved the main features we go into the details</li> <li>- the attributes of common features in mechanical components (rib, web, holes, lug, chamfers,...)</li> </ul>
		<p>Analysis of results (confirmation of the image) :</p> <ul style="list-style-type: none"> <li>- In agreement with the data</li> </ul> 



6. A truncated cone (see illustration in introduction) is going to be cut by a plane.

Which of the following surface(s) can result ?

i



ii



iii



(A) I, II, and III  
(B) only I and II  
(C) only II and III

8. Two pillars with different lengths and same square cross section are merged together to a "L" without any "joint".

Which of the following statement/s is/are correct ?

This "L" can be cut by a plane in such way that the resulting cut surfaces are:

I. two equal non-square rectangles  
II. a square and a non-square rectangle  
III. two unequal non-square rectangles

(A) only statement I is correct  
(B) only statement II is correct  
(C) only statement III is correct  
(D) only statements I and II are correct  
(E) I, II and III are all correct

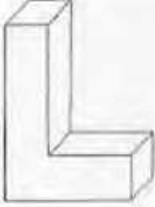

Fig. 41. Exercises (2 of 17) from high Visualization Test [17]

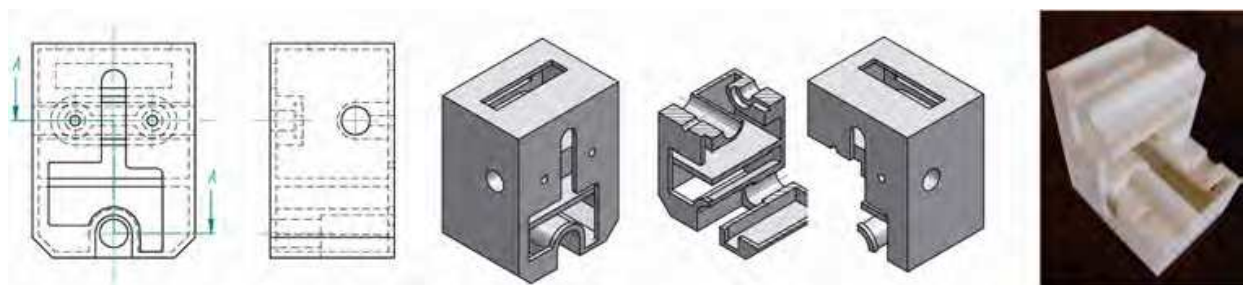

Fig. 42. Exercises with high level of spatial Visualization, CAD and physics model

Steps	Indicator to work	Carry Out Indicators	Dimensions	Types of activity
7	8 and 10	1,2,3,4,5,6,7,8,9,10 Spatial Visualization	From 2D to 3D From 2D to (3D) 2D	Piece solving with Industrial characteristics elements with new views/cuts (Sketches)

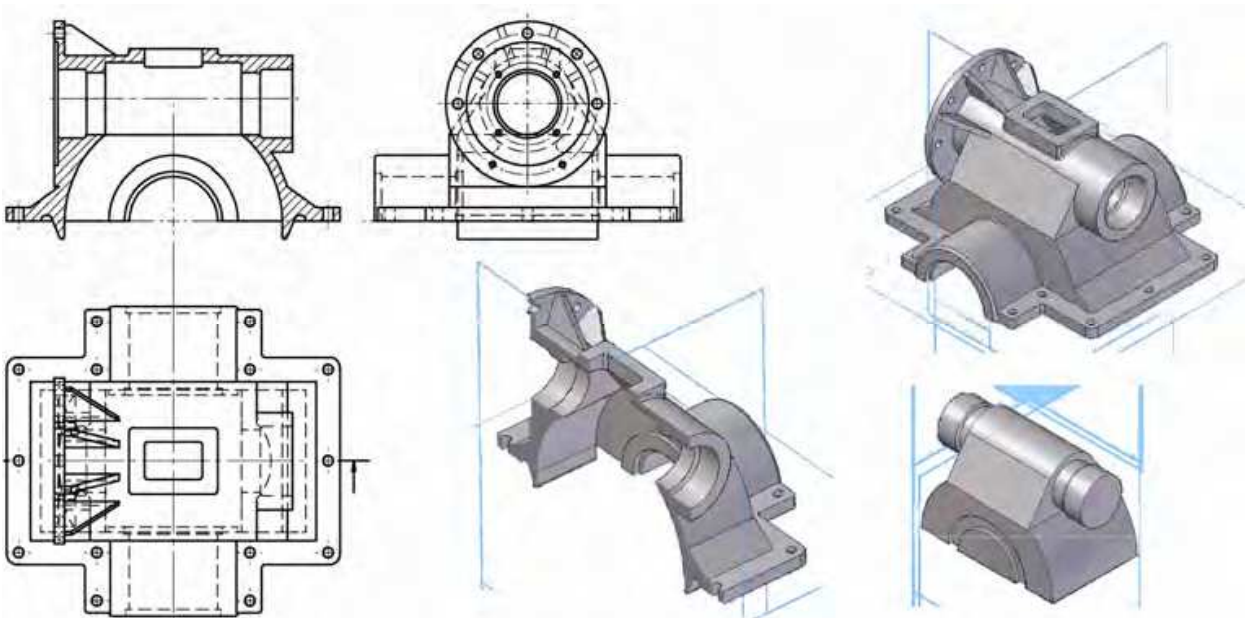
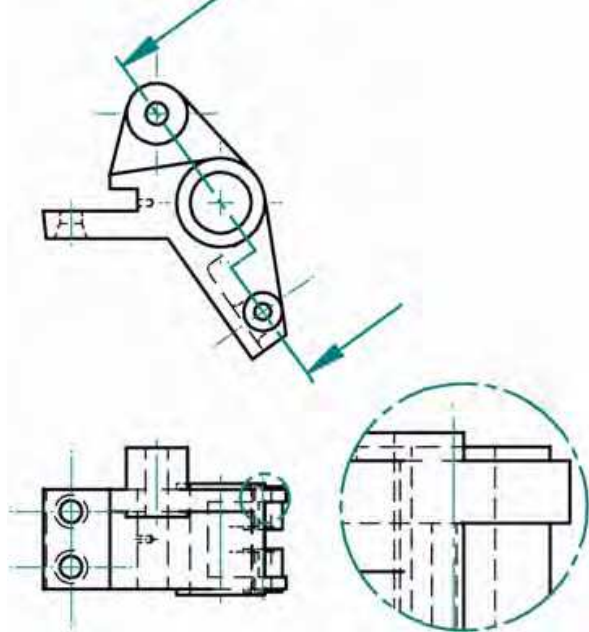
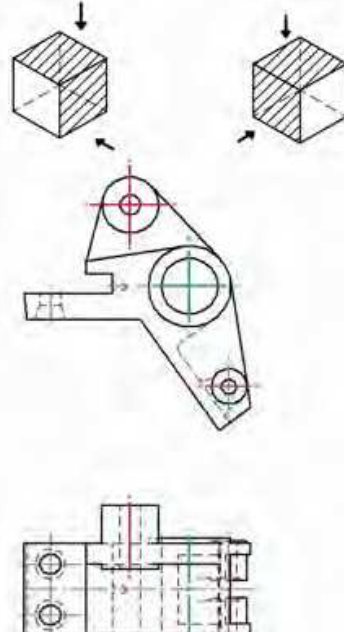
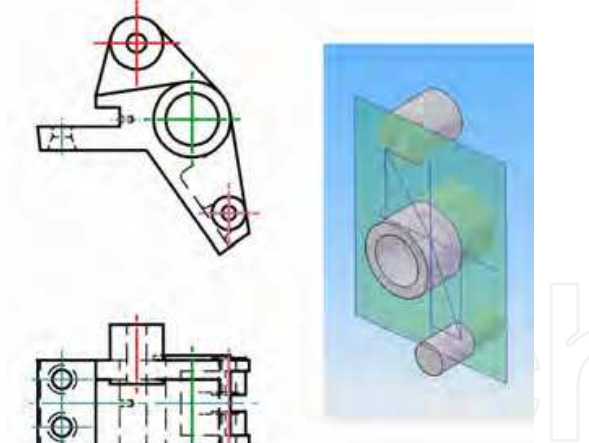
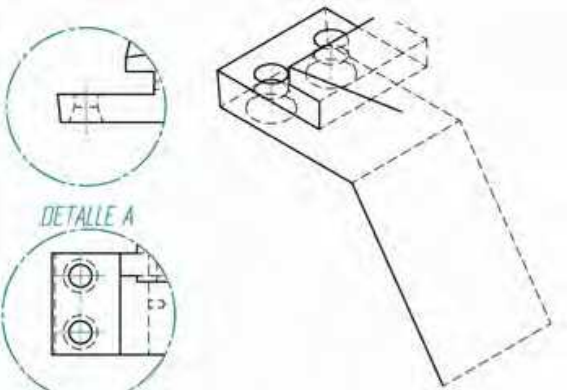
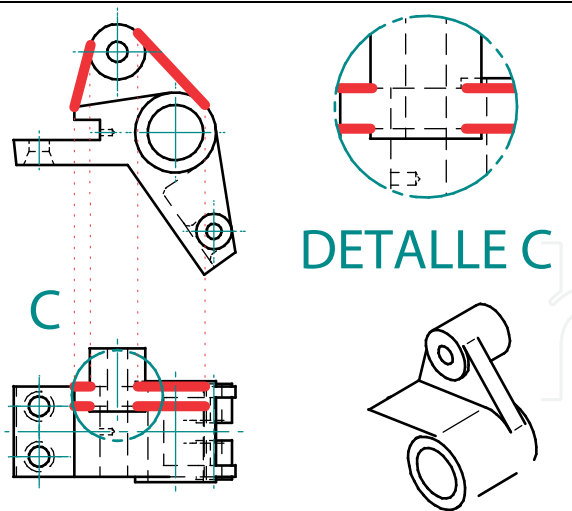
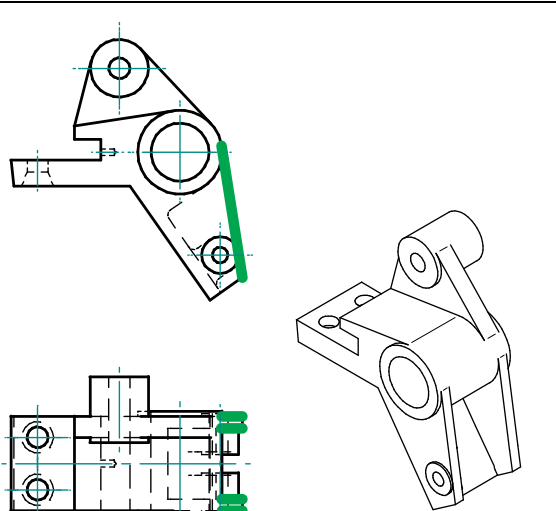
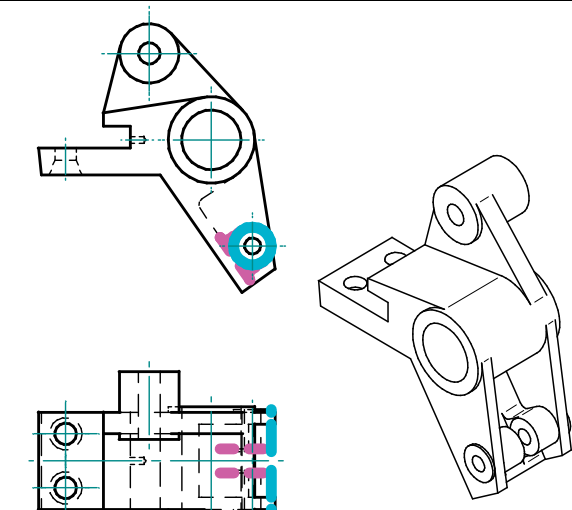
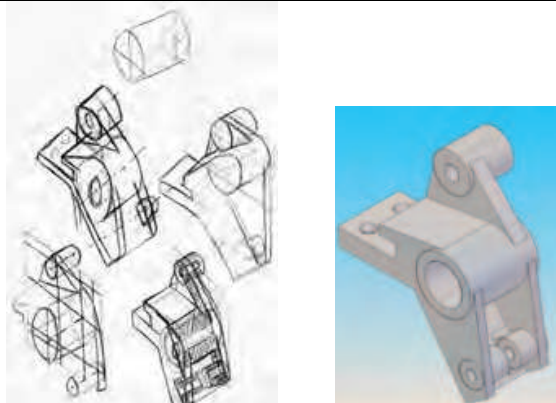
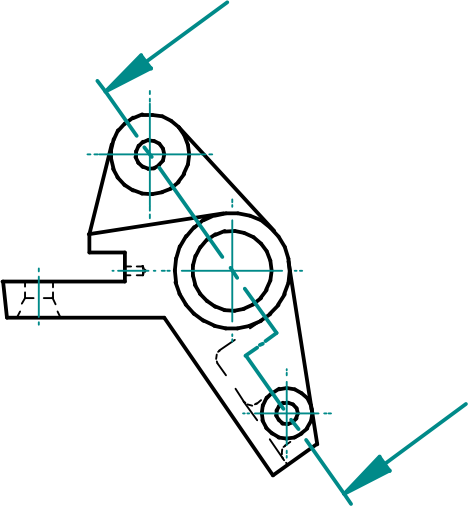
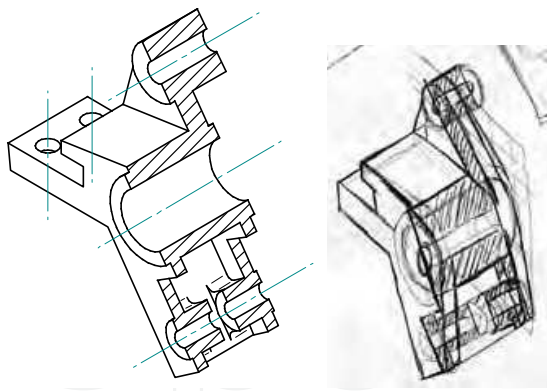
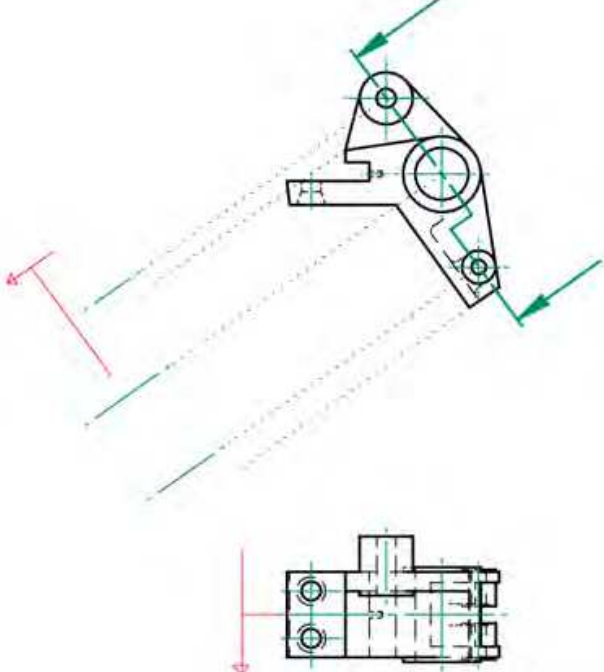
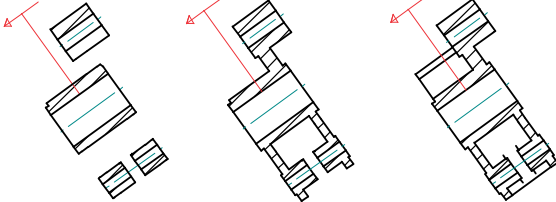

Fig. 43. Exercise with industrial features, intersection and tangency between surfaces and negative elements (vacuum)

Table 2. Example of resolution process with high level exercise, the student must sketch the piece and draw the cut by hand

 <p>Before cutting the piece we must visualize it</p>	 <p>Analyzing types of cutting views/ views Analyzing types of pieces (prisms, symmetry, elements)</p>
 <p>Identifying revolving axes (material) Iterative process to solve the main features (<u>breaking down the elements</u>)</p>	 <p>Breakdown of the analysis (sub-problems) (general-to-detail / left-to-right / top-to-bottom / outside-to-inside)</p> <p>On the left side the two holes show as the limit planes</p>

 <p>DETALLE C</p> <p>Parallel and finite lines (surface tangency) show as the different webs linking the main elements (cylinders and prism)</p>	
 <p>Analysis of results (confirmation of the image) in agreement with the data</p>	 <p>Solving (making the image) / Drawing (mental/freehand):          Sketching process (principle axes/boxing-in, auxiliary points and lines, proportional)          Sketching sequence (linked with the problem-solving sequence)</p>

 <p>Once we have understood the piece we can proceed with the cutting.</p>	 <p>The cutting viewpoint tells which part has to be removed</p>
	 <p>Auxiliary lines helps us to draw the axes parallels to the view point and centered with the front view cylinders          Using a reference (red line), we can obtain the dimensions of the top view.          We draw the 3 cylinders (half cylinder) which are the main features.          Afterwards, we proceed to draw the webs linking the different cylinders (we must grate the webs because it is a transversal cut)          At the end we draw the edges that are seen.</p>

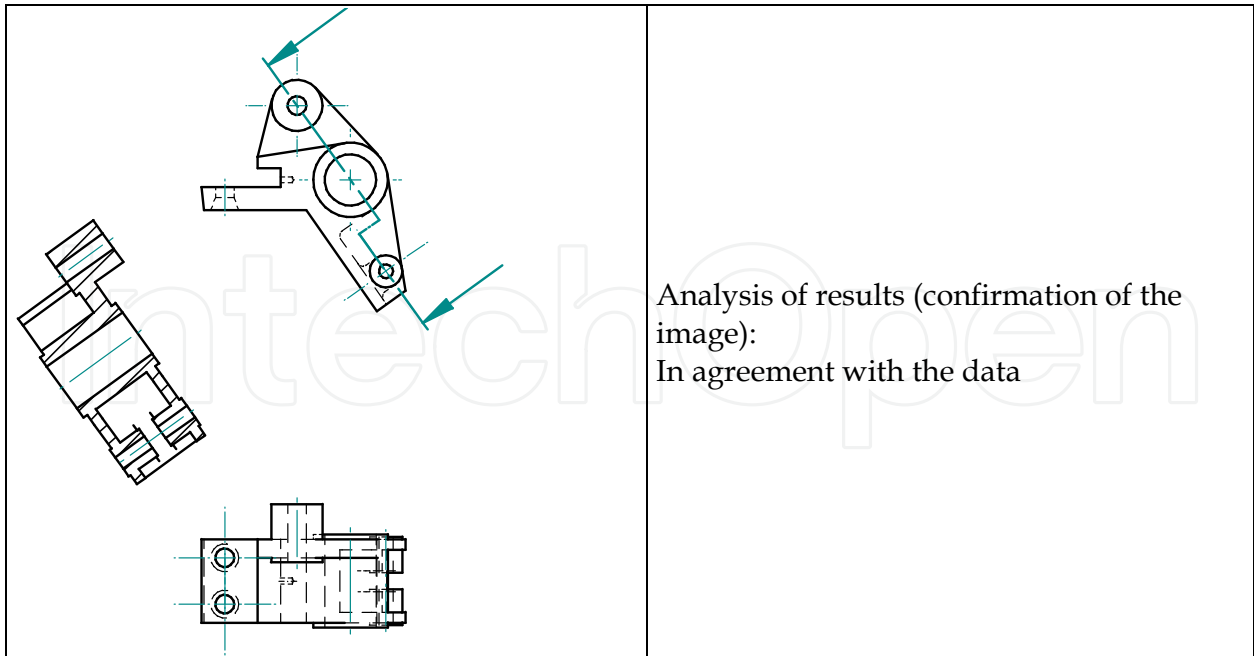

Analysis of results (confirmation of the image):  
In agreement with the data

Steps	Indicator to work	Carry Out Indicators	Dimensions	Types of activity
8	10 Spatial Visualization	1,2,3,4,5,6,7,8,9,10 Spatial Visualization	From 2D to 3D From 2D to (3D) 2D	Exam exercises Working the spatial visualization (Visualization Test) [16]

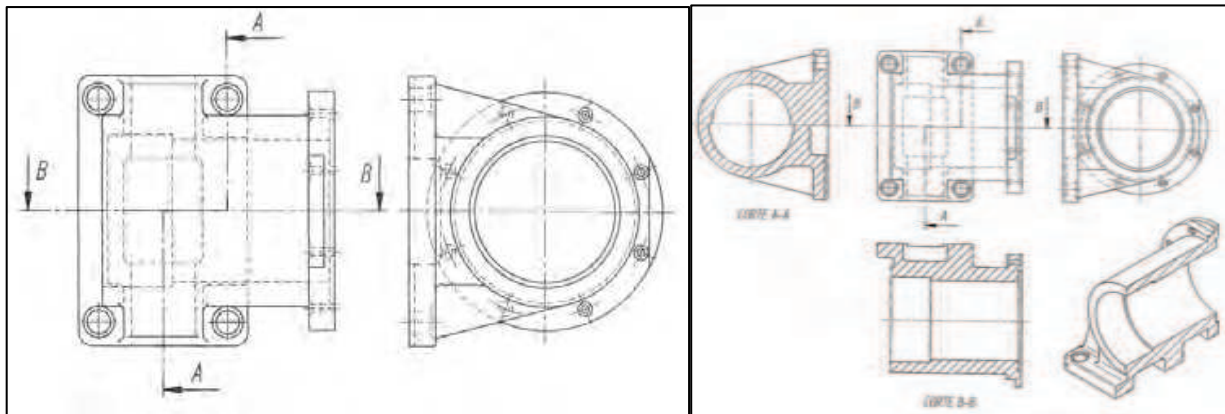

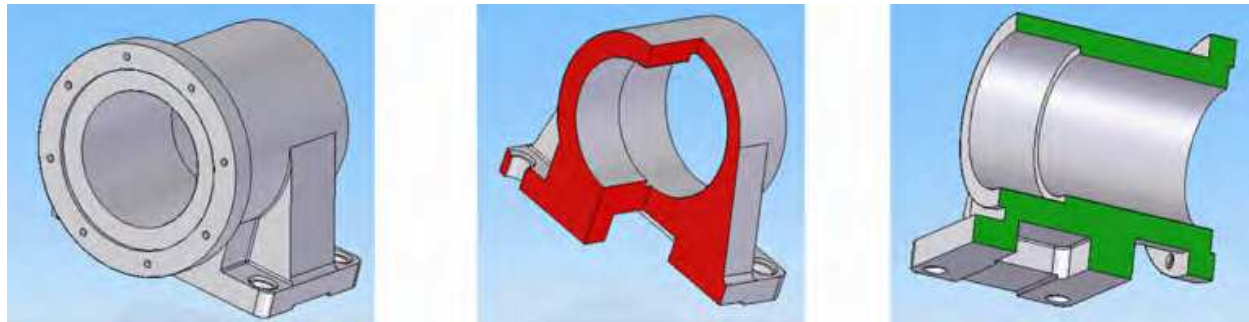

Fig. 44. Evaluation of knowledge acquisition when solving visualization problems: the students had to do it by hand despite the formulation and the solution in this case being CAD made (Example of exercise in step 8)

### 5. Results and Conclusions

Analyzing the results of the Visualization exercises at official examinations, the average (t student) between the group that has used the described method (experimental group) and the rest of the students (control group), which has continued with traditional teaching, is significantly different.

Table 3 and 4. Group size and exam averages, Industrial Engineering

Industrial Engineering	06-07 course	07-08 course
Experimental Group size	46	56
Control Group size	257	279

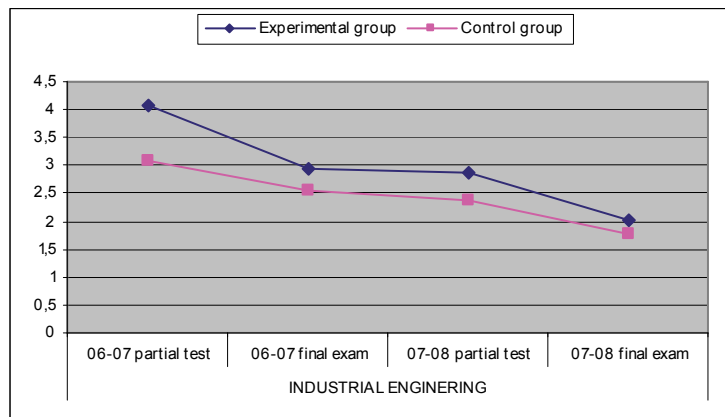
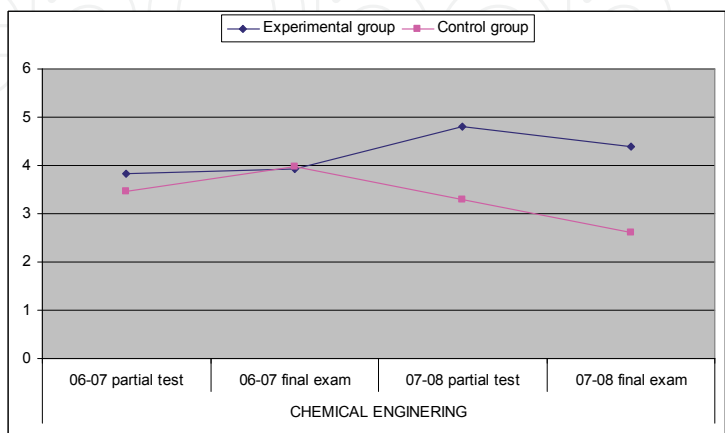

Table 5 and 6. Group size and exam averages, Chemical Engineering

Chemical Engineering	06-07 course	07-08 course
Experimental Group size	25	25
Control Group size	20	9



Some special tests have been performed and recorded individually with some students in both groups. These tests show that the experimental group follows a reasonable method of resolution whilst the control group keeps on basing its work on experience and intuition. It was also noted that the more limited is the students' prior knowledge (typical Chemical Engineering students' profile) the better (s)he works with the new methodology. Besides, a higher attendance to the final exam and a lower demand for private lessons at the end of the semester was registered in the experimental group.

## 6. References

- A. Park, K. Dodds, S. Bland. *Technology Drawing*. 1989 (Logman Chesire, Sydney)
- Bertoline G., Wiebe E., Miller C., Mohler J. *Dibujo en ingeniería y comunicación gráfica*. 1995 (Mc Graw Hill, Mexico)
- Devon, R., Engle, Foster, Sathianathan, Turner The effect of solid modelling software on 3D visualizations skills. *Engineering Design Graphics Journal*, 1994, 58(2); pp. 4-11.
- Dr. Claudia Quaiser-Pohl. The Mental Cutting Test "Schitte" and the Picture Rotation Test- Two New Measures to Assess Spatial Ability. *International Journal of Testing*, Volume 3, Issue 3 September 2003, pages 219 - 231
- Fernando Hernández, Juana María Sancho, *Para enseñar no basta con saber la asignatura*. 1993 (Ed. Paidós, Barcelona, Spain)
- Frederick E. Giesecke, Alva Mitchell, Henry Cecil Spencer, Ivan Leroy Hill, Robert Olin Loving, John Thomas Dygdon "*Engineering Graphics*" (fourth edition) 1987 (Paramus, NJ, U.S.A., Prentice Hall)
- Garmendia M. *Análisis crítico de la enseñanza de visualización en primer ciclo de universidad y propuesta alternativa de orientación constructivista*. PhD in Engineering Design Graphic Education, (2004) Basque Country
- Gary R. Bertoline, Eric N. Wiebe *Technical Graphics Communication*. (third edition). 2003 (Mc Graw Hill)
- Guisasola, J., Furió C., Ceberio, M. and Zubimendi, J.L. ¿Es necesaria la enseñanza de contenidos procedimentales en cursos introductorios de física en la universidad? *Enseñanza de las Ciencias*, extra number, 17-28(2003)
- J. Gonzalo Gonzalo. *Dibujo Técnico Enseñanzas Secundarias*. 1994 (Editorial Donostiarra)
- Kedmon Hungwe, Thomas Drummer, Sheryl A. Sorby, Paul Charlesworth. Developing 3-D Spatial Visualization Skills for Non-Engineering Students. *Journal of Engineering Education*, Jul 2000, 63(2), pp. 21-32
- Luzzader W.J. y Duff J.M. *Fundamentos de dibujo en ingeniería*. 1986 (Prentice Hall. Hispanoamericana Mexico)
- M. Garmendia, J. Guisasola, E. Sierra. First year engineering students' difficulties in visualization and drawing tasks. *European Journal of Engineering Education*, 2007. Volume 32 Issue 3
- Mathewson, J.H. Visual-spatial thinking: An aspect of science overlooked by educators. *Science & Education*, 1999, 83(1), pp. 33-54.
- Navarro R. El dibujo de croquis y la visualización espacial: su aprendizaje y valoración en la formación del ingeniero a través de las nuevas tecnologías. *XII Congreso Universitario de Innovación Educativa en las Enseñanzas Técnicas*. XII CUIEET 2004 Barcelona, Spain.

- Potter C.S. and Van Der Merwe, E. Percepcion, imagery, visualization and engineering graphics. *European Journal of Engineering Education*, 2003, VOL 28, n°1, 117-133
- Randolph P. Hoelscher, Clifford H. Springer. *Graphics for engineers. Visualization, communication and desing* (1964, Wiley International edition)
- S. Bogoliúbov, *Tareas para el curso de Dibujo Técnico*. 1989 (editorial Mir Moscu)
- Sarah Titus, Eric Horsman. *The Visualization Survey*. Univ. of Wisconsin-Madison
- Sierra Uria, Egoitz, Master in Engineering Design Graphic Education 2006. Análisis de la asimilación de la competencia "ver en el espacio" en el ámbito de los estudios de ingeniería. *XIII Congreso Universitario de Innovación Educativa en las Enseñanzas Técnica.XIICUIEET Canarias, Spain*. 2005 pp. 30.
- Vygotsky, L.S. *Mind in Society*. Cambridge, MA: Harvard University Press (1978).

IntechOpen



IntechOpen

IntechOpen



## **New Achievements in Technology Education and Development**

Edited by Safeeullah Soomro

ISBN 978-953-307-066-7

Hard cover, 460 pages

**Publisher** InTech

**Published online** 01, March, 2010

**Published in print edition** March, 2010

Since many decades Education Science and Technology has an achieved tremendous recognition and has been applied to variety of disciplines, mainly Curriculum development, methodology to develop e-learning systems and education management. Many efforts have been taken to improve knowledge of students, researchers, educationists in the field of computer science and engineering. Still many problems to increase their knowledge on daily basis so this book provides newly innovations and ideas in the field of computer science and engineering to face the new challenges of current and future centuries. Basically this book open platform for creative discussion for future and current technologies to adapt new challenges in education sector at different levels which are essential to understand for the students, researchers, academic personals and industry related people to enhance their capabilities to capture new ideas and provides valuable contribution to an international community.

### **How to reference**

In order to correctly reference this scholarly work, feel free to copy and paste the following:

E. Sierra Uria and M. Garmendia Mugika (2010). Methodology for Part Visualization Problem Solving - the Importance of the Process, New Achievements in Technology Education and Development, Safeeullah Soomro (Ed.), ISBN: 978-953-307-066-7, InTech, Available from: <http://www.intechopen.com/books/new-achievements-in-technology-education-and-development/methodology-for-part-visualization-problem-solving-the-importance-of-the-process>

**INTECH**  
open science | open minds

### **InTech Europe**

University Campus STeP Ri  
Slavka Krautzeka 83/A  
51000 Rijeka, Croatia  
Phone: +385 (51) 770 447  
Fax: +385 (51) 686 166  
[www.intechopen.com](http://www.intechopen.com)

### **InTech China**

Unit 405, Office Block, Hotel Equatorial Shanghai  
No.65, Yan An Road (West), Shanghai, 200040, China  
中国上海市延安西路65号上海国际贵都大饭店办公楼405单元  
Phone: +86-21-62489820  
Fax: +86-21-62489821

© 2010 The Author(s). Licensee IntechOpen. This chapter is distributed under the terms of the [Creative Commons Attribution-NonCommercial-ShareAlike-3.0 License](#), which permits use, distribution and reproduction for non-commercial purposes, provided the original is properly cited and derivative works building on this content are distributed under the same license.

IntechOpen

IntechOpen